

TEAM APOLLO

Engineering

CASE SSV PART 2

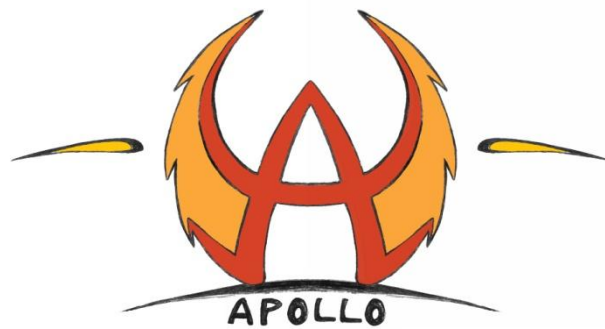

13-5-2011



INDEX

Introduction	2
1. The new sankey diagram.....	2
1. Rolling resistance	2
2. Air resistance.....	3
3. Losses due to internal friction.....	3
4. New losses.....	3
2. Driven shaft analysis	5
1. Sketch of the shaft and all attached components	5
2. List of parameters that determine the mechanical load	5
3. Calculation of bending stress, shear stress and torsional stress + sketch	6
4. Extra Parameters when car has a certain speed.....	10
3. Sankey diagram of umicar	11
1. Top speed	11
2. Half speed.....	13
4. 2D technical drawing.....	15
Appendix	18

CASE SSV PART 2

INTRODUCTION

In the previous report case SSV part 1, we generally calculated and simulated to have an idea of some important choices we had to make to build our SSV and optimize it to be as quick as possible.

In this report, we revise our car and look what could have been better, correct what we could not now for sure, etc. This report contains 4 parts: A new and corrected Sankey Diagram, driven shaft analysis, a sankey diagram of the real Umicar and a technical drawing of our SSV.

In the appendix, you can find the Solid Edge drawings.

1. THE NEW SANKEY DIAGRAM

When we let our SSV roll down from 1 meter of the ramp we reached 80 cm on the flat part of the track, while in the simulation we reached 2,4 meters. So there is a big difference. There are many factors that account for this difference. Maybe the most important one is the track itself, in the flat part of the track there was a little bump. The track went up a little bit, this caused our SSV to stop. So if the bump was not there, maybe we could have reach 1 meters.

Next to the bump, the reasons why we slow down is rolling resistance, aerodynamic losses and some friction with the bearings, gears and motor.

Because we did not disconnect the gears and motor from the axis we also got losses here since these form an opposing force. The rolling resistance is different than in the first Sankey diagram since we made an assumption about the rolling resistance coefficient.

1. ROLLING RESISTANCE

Since in the beginning there is only potential energy, we can calculate the amount of energy here by

$$E = m \cdot g \cdot h$$

At the end, where our SSV stopped, there is no energy left. All the energy is lost due to friction. Because this is the only force that “works”, it is the only force that will consume energy.

This means that the amount of energy at the start point is all “used” by the rolling



resistance.

The friction force is equal to:

$$F_r = N \cdot C_{rr}$$

The energy lost during the rolling is force times distance. So:

$$E = F_r \cdot s$$

Therefore:(the mass of the SSV is equal to 0.85 kg):

$$m \cdot g \cdot h = N \cdot C_{rr} \cdot s$$

$$N \cdot C_{rr} \cdot s = g \cdot \cos 3^\circ \cdot m \cdot C_{rr} \cdot d_{slope} + g \cdot m \cdot C_{rr} \cdot d_{flat}$$

So:

$$m \cdot g \cdot h = g \cdot \cos 3^\circ \cdot m \cdot C_{rr} \cdot 1 + g \cdot m \cdot C_{rr} \cdot 1$$

$$m \cdot g \cdot \sin 3^\circ = g \cdot \cos 3^\circ \cdot m \cdot C_{rr} \cdot 1 + g \cdot m \cdot C_{rr} \cdot 1$$

The only unknown factor is C_{rr} which is equal to:

$$C_{rr} = 0.0262$$

$$F_r = 0,85 \cdot 9,81 \cdot 0,0262 = 0,218 \text{ N}$$

If we compare this with the first force we have calculated ($F_{r1} = 0.125 \text{ N}$), we see that we have a lot more friction.

2. AIR RESISTANCE

Since we did not do any changes at the shape of our SSV, the air resistance is also not changed. This means this will stay the same.

3. LOSSES DUE TO INTERNAL FRICTION

With internal friction we mean the losses due to friction in the bearings, the gears, ... These amount of losses can only be estimated. It is reasonable to assume that these frictions lead to a 5% loss of power.

4. NEW LOSSES

With these new calculations we can change our original Sankey-diagram. This Sankey-diagram was calculated for the situation where the SSV was on the flat part of the track and has the power that is available at the 'top power point.' The speed at this point is equal to:



$$v = 2,99 \frac{m}{s}$$

Since there are losses due to the gears the total power available is not 4.004 W. The losses are 5%, this means that there is only 3.80 W available.

The air resistance still takes 0.072 W. But the rolling resistance is changed. The rolling resistance uses actually 0.652 W ($F_r \cdot v$) instead of 0.44 W. This means that there is only 3.076 W left for acceleration.

This leads to the following, new Sankey-diagram:

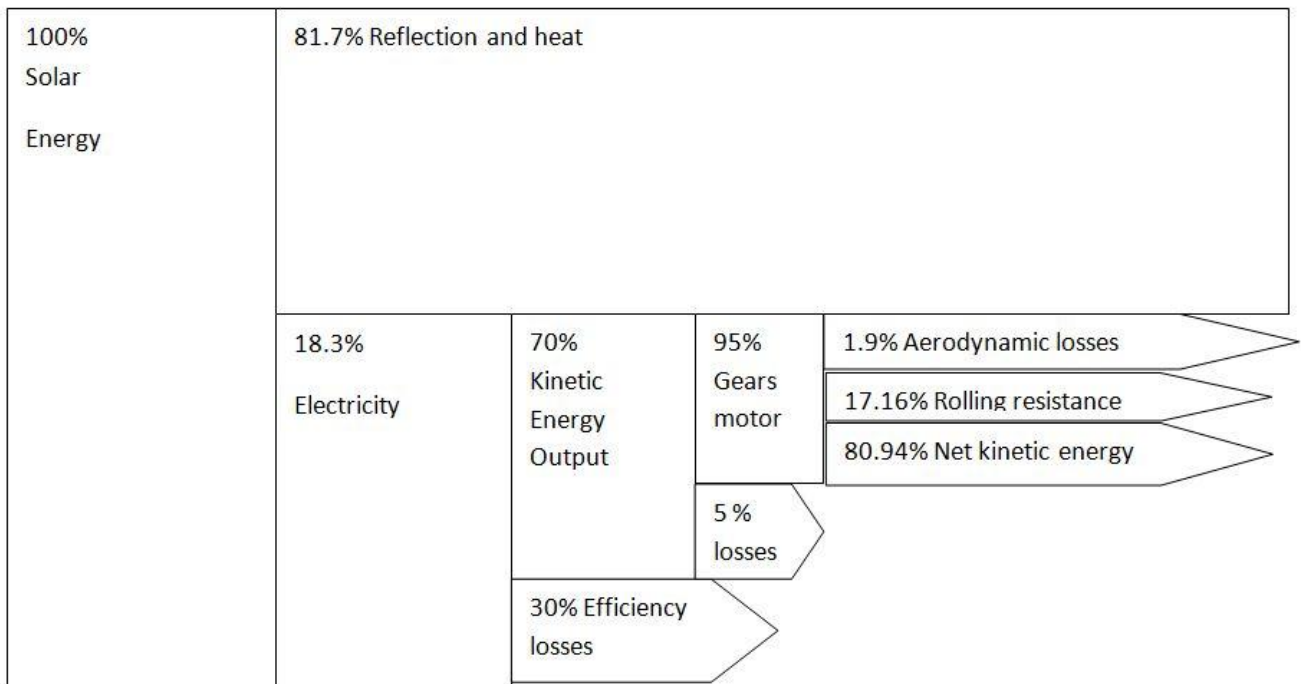

Figure 1: New Sankey Diagram

2. DRIVEN SHAFT ANALYSIS

In this part, we will make an analysis of the driven shaft of our SSV, this will make clear whether or shaft is dimensioned well. This analysis is made with the perception of the motor that delivers torque to the shaft but the car is not driving yet.

1. SKETCH OF THE SHAFT AND ALL ATTACHED COMPONENTS

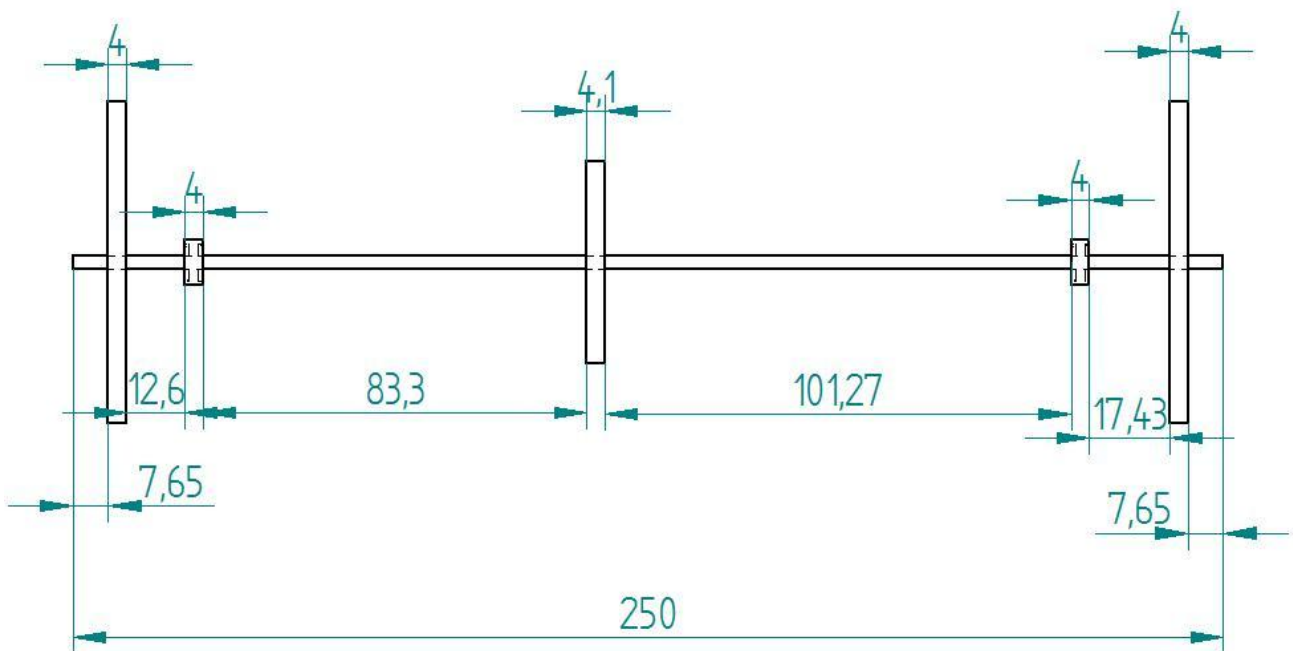

Figure 2: Sketch of shaft and attached components

The middle component is a driven gear of the motor, the two small components are the bearings. The bearings are the connection between the frame and the driven shaft. The two biggest components are the wheels of our SSV.

2. LIST OF PARAMETERS THAT DETERMINE THE MECHANICAL LOAD

- The torque of the motor
- The gear ratio
- The length of the shaft
- The shape of gear tooth
- The diameter of the shaft
- The material of the shaft
- The weight of the car and weight distribution
- The spatial division of bearings, gears and wheels on the shaft
- The roll resistance of the wheels



3. CALCULATION OF BENDING STRESS, SHEAR STRESS AND TORSIONAL STRESS + SKETCH

CALCULATE THE TORQUE DELIVERED BY THE MOTOR:

- $T = k \cdot I \cdot \eta \cdot i$
- $k = 8.55 \text{ mNm/A}$, torque constant
- $I = 0.88 \text{ A}$, max current (initial current) of the solar panel
- $\eta = 0.7$, the efficiency of the motor
- $i = 8$, the gear ratio

$$T = 8.55 \times 10^{-3} \cdot 0.88 \cdot 0.7 \cdot 8 = 0.042 \text{ N} \cdot \text{m} \text{ (0.0421344 N} \cdot \text{m)}$$

For $T = F \cdot R_{\text{gear}}$, where $R_{\text{gear}} = \frac{4.108 \text{ cm}}{2} = 0.02054 \text{ m}$

- $F = \frac{0.0421344}{0.02054} = 2.051 \text{ N}$
- $F_{\text{vertical}} = F = 2.051 \text{ N}$
- $F_{\text{horizontal}} = F_h = F \cdot \tan 20^\circ = 0.747 \text{ N}$

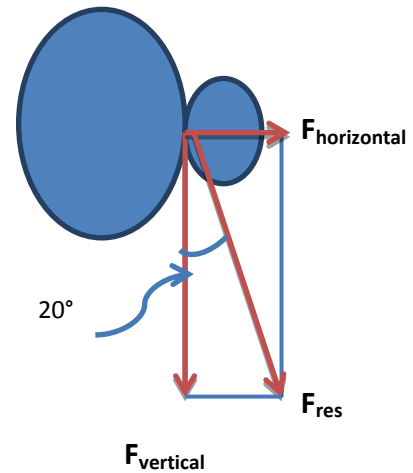

ANALYZE THE DISTRIBUTION OF TORQUE OF TORQUE ON THE SHAFT:

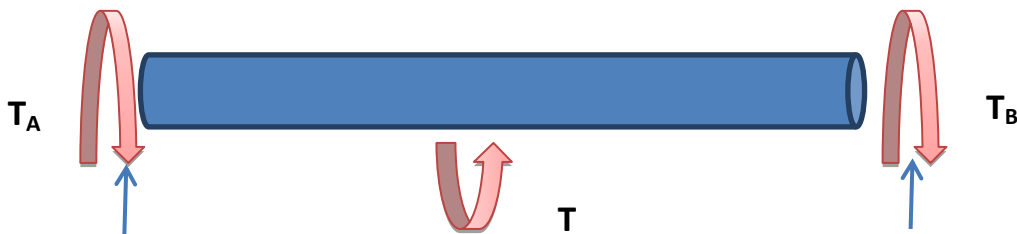

$$\text{Torque balance: } T_A + T_B = T$$

There is no relative angle shift between A and B (The shaft is not twisted).

- $\phi_{A/B} = 0 \rightarrow \phi_{C/A} + \phi_{C/B} = 0$
- $-T_A \cdot \frac{L_{AC}}{G \cdot I_p} + T_B \cdot \frac{L_{CB}}{G \cdot I_p} = 0$ (G is shear modulus)
- $T_A \cdot L_{AC} = T_B \cdot L_{CB}$
- $L_{AC} = 10.8 - \frac{0.41+0.41}{2} \text{ cm} = 0.10390 \text{ m}$
- $L_{CB} = 13.49 - \frac{0.41+0.41}{2} \text{ cm} = 0.1308 \text{ m}$



$T_A = 0.023 \text{ N}\cdot\text{m}$
 $T_B = 0.019 \text{ N}\cdot\text{m}$
 The diagram (T-x) we can get:

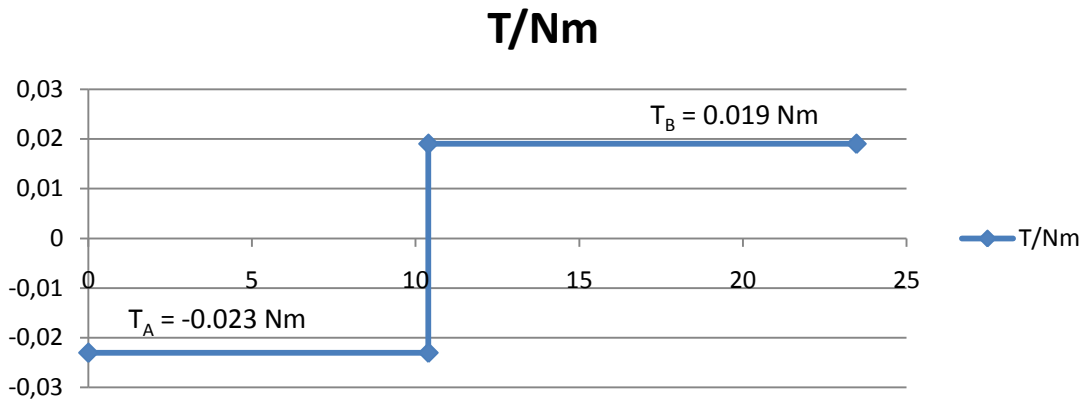

CALCULATE THE MAX TORSIONAL STRESS (SHEAR STRESS CAUSED BY TORSION)

$$\tau_{MAX} = \frac{(T_{max} \cdot R)}{I_P} \quad \text{Where } I_P = \int_A \rho^2 dA \quad (A - \text{area}, \rho - \text{radius})$$

$$I_P = \frac{1}{2} \cdot \pi \cdot R^4 \quad R = 0.00155 \text{ m (radius of shaft)}$$

$$T_{max} = 0.023 \text{ N}\cdot\text{m} \rightarrow \tau_{MAX} = \frac{0.023 \cdot 0.00155}{0.5 \cdot \pi \cdot 0.00155^4} = 3.932 \text{ MPa}$$

ANALYZE THE DISTRIBUTION OF THE SHEAR FORCE:

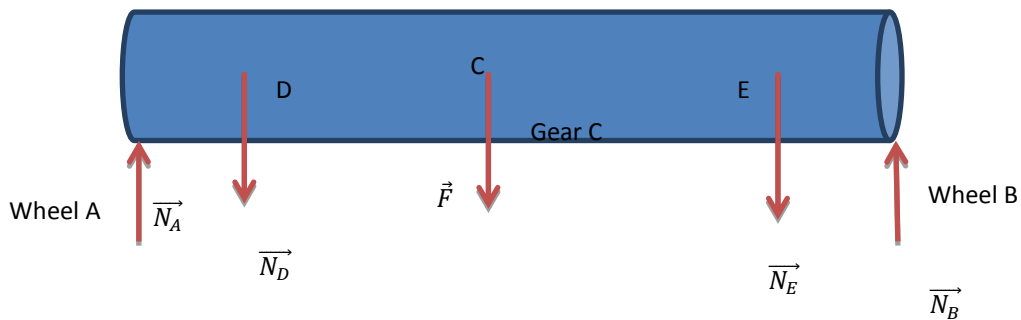

$$L_{AD} = 0.023175 \text{ m}, L_{DC} = 0.080725 \text{ m}, L_{CE} = 0.108575 \text{ m}, L_{EB} = 0.02225 \text{ m}$$

About N_A and N_B , make an assumption that $N_A = N_B$ (property of symmetry)

$$\text{For } m_{car} = 0.85 \text{ kg}, \rightarrow G_{car} = m_{car} \cdot g = 0.85 \cdot 9.81 = 8.339 \text{ N}$$

Consider the situation of the weight distribution, take $N_A = N_B = \frac{3}{10} \cdot G_{car} = 2.502 \text{ N}$.

$$\text{Force balance: } N_A + N_B - N_D - N_E - F = 0$$

$$\text{Moment balance about D: } L_{DB} \cdot N_B - L_{DC} \cdot F - L_{DE} \cdot N_E - L_{AD} \cdot N_A = 0$$

$$\begin{cases} N_D + N_E = 2.953 \text{ N} \\ 0.211525 \cdot 2.502 - 0.080725 \cdot 2.051 - 0.1893 \cdot N_E - 0.023175 \cdot 2.502 = 0 \\ N_D = 1.338 \text{ N}, N_E = 1.615 \text{ N} \end{cases}$$



The diagram of the V-x:

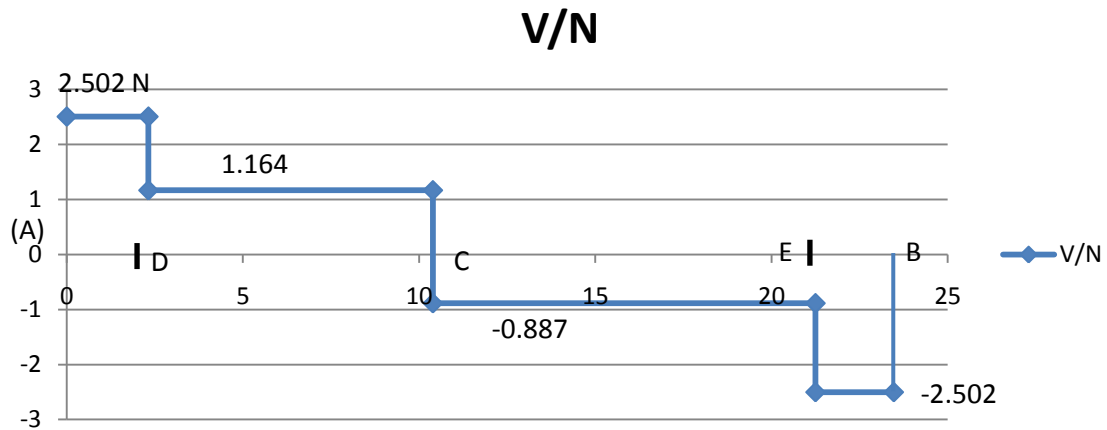

CALCULATE THE MAX SHEAR STRESS:

$$\tau_{MAX} = \frac{V_{max} \cdot Q}{I \cdot t}$$

$$\text{Where } Q = \int_{A'} y \, dA = \int_0^R y \cdot \sqrt{R^2 - y^2} \cdot 2dy = -\int_0^R \sqrt{R^2 - y^2} \, d(R^2 - y^2) = 0R2t \, dt = 23 \cdot t320R2 = 23R3 \text{ (A - area)}$$

$$I = \frac{1}{4} \cdot \pi \cdot R^4, \quad t \text{ (thickness)} = 2R$$

$$\Rightarrow \tau_{MAX} = \frac{V_{max} \cdot \frac{2}{3}R^3}{\frac{1}{4}\pi R^4 \cdot 2R} = \frac{4 \cdot V_{max}}{3 \cdot \pi \cdot R^2} = 0.442 \text{ MPa}$$

ANALYZE THE DISTRIBUTION OF BENDING MOMENT:

For $v = \frac{dM}{dx}$, from $v \rightarrow M$,

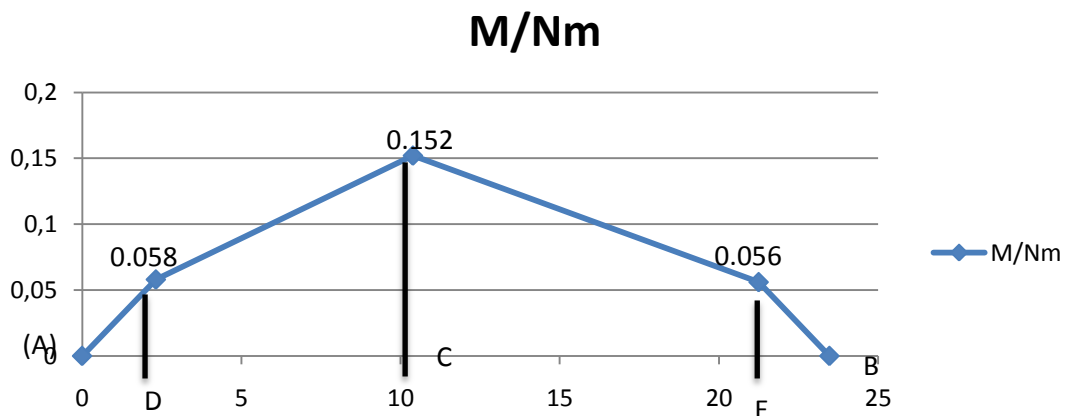

CALCULATE THE MAX BENDING STRESS (NORMAL STRESS DUE TO BENDING)

$$\sigma_{MAX} = \frac{M_{max} \cdot R}{I}, \text{ where } I = \frac{1}{4} \cdot \pi \cdot R^4, \quad M_{max} = 0.152 \text{ N/m}$$



$$\sigma_{MAX} = \frac{4 \cdot M_{max}}{\pi \cdot R^3} = \frac{4 \cdot 0.152}{\pi \cdot 0.00155^3} = 51.971 \text{ MPa}$$

ANALYZE THE DISTRIBUTION OF THE HORIZONTAL SHEAR FORCE WITH HORIZONTAL BENDING MOMENT:

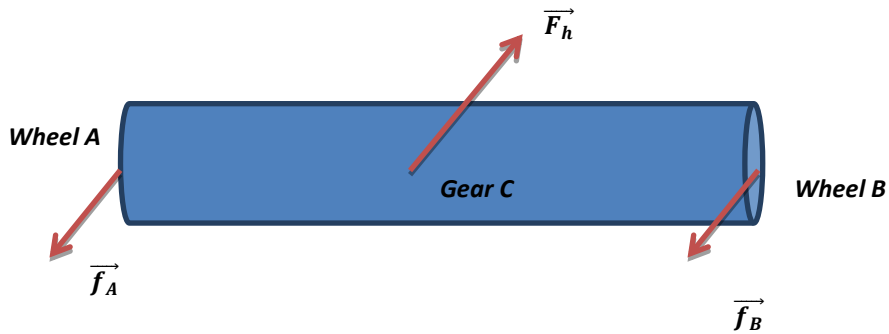

f_A, f_B --- friction of the wheel

Force balance: $f_A + f_B = F_h$

Moment balance about A: $L_{AC} \cdot F_h - L_{AB} \cdot f_B = 0$

$$\left\{ \begin{array}{l} f_A = 0.416 \text{ N} \\ f_B = 0.331 \text{ N} \end{array} \right.$$

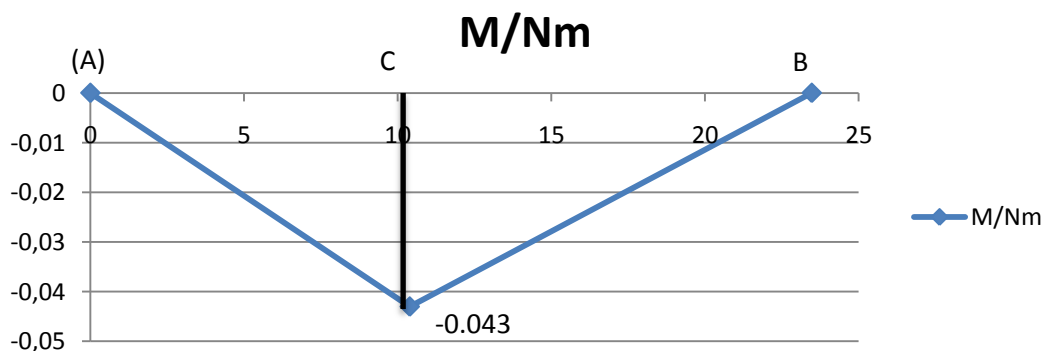
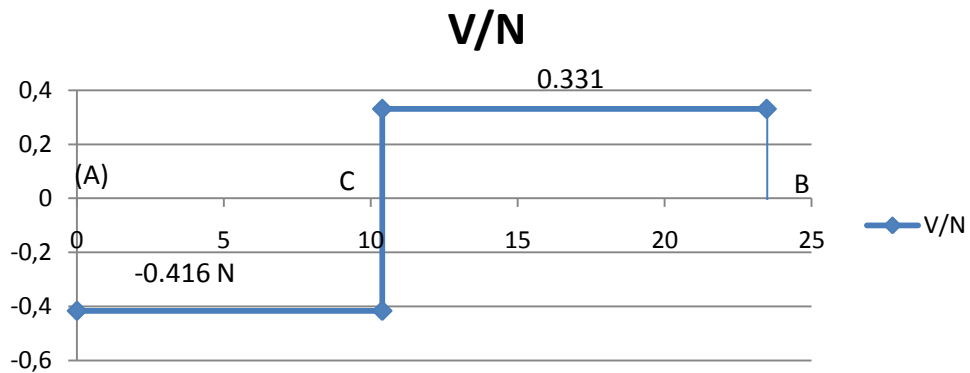

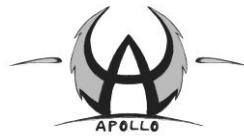

CALCULATE THE MAX HORIZONTAL SHEAR STRESS WITH THE MAX HORIZONTAL BENDING STRESS:

$$\tau_{MAX} = \frac{V_{max} \cdot Q}{I \cdot t}, \text{ where } Q = \frac{2}{3} \cdot R^3, I = \frac{1}{4} \cdot \pi \cdot R^4, t = 2 \cdot R, V_{max} = 0.416 \text{ N}$$

$$\tau_{MAX} = \frac{V_{max} \cdot Q}{I \cdot t} = \frac{4 \cdot 0.043}{\pi \cdot 0.00155^2} = 0.073 \text{ MPa}$$

$$\sigma_{MAX} = \frac{M_{max} \cdot R}{I}, \text{ where } I = \frac{1}{4} \cdot \pi \cdot R^4, M_{max} = 0.043 \text{ N} \cdot \text{m}$$

$$\sigma_{maxh} = \frac{4 \cdot M_{max} \cdot h}{\pi \cdot R^3} = \frac{4 \cdot 0.043}{\pi \cdot 0.00155^3} = 14.702 \text{ MPa}$$

CALCULATE THE TOTAL MAX SHEAR STRESS WITH THE TOTAL MAX BENDING STRESS:

$$\tau_{max t} = \sqrt{\tau_{max}^2 + \tau_{maxh}^2} = 0.448 \text{ MPa}$$

$$\sigma_{max t} = \sqrt{\sigma_{max}^2 + \sigma_{maxh}^2} = 54.010 \text{ MPa}$$

4. EXTRA PARAMETERS WHEN CAR HAS A CERTAIN SPEED

- Speed of the car
- Terrain where car drives
- Acceleration of the car

3. SANKEY DIAGRAM OF UMICAR

In this part, we will try to compose the Sankey Diagram of the Umicar during the Solar Challenge 2009. This has to be done in 2 cases, when the car has reached top speed and when it is driving at half speed.

1. TOP SPEED

We assume the Umicar has reached top speed and a power of $1000 \frac{W}{m^2}$ from the sun.

To determine the full power absorbed by the solar panel, we need to know the surface that is covered by the different solar cells. The total solar panel consists of 280 RWE solar cells with an efficiency of 30% and 2578 Emcore solar cells with an efficiency of 24,5%. One RWE solar cell covers an area of $30,18 \text{ cm}^2$ and one Emcore cell an area of $27,44 \text{ cm}^2$.

So all the solar cells have a total area of:

$$\begin{aligned} \text{RWE cells: } & 280 \cdot 30,18 \cdot 10^{-4} \text{ m}^2 = 0,845 \text{ m}^2 \\ \text{Emcore cells: } & 2578 \cdot 27,44 \cdot 10^{-4} \text{ m}^2 = 7,074 \text{ m}^2 \end{aligned}$$

The total power delivered by the sun is then equal to:

$$P_{tot} = 1000 \frac{W}{m^2} \cdot (0,845 \text{ m}^2 + 7,074 \text{ m}^2) = 7919 \text{ W}.$$

This power available from the sun is not completely transformed into electrical power because the solar cells do not have an efficiency of 100%. Therefore the total power delivered to the motor is equal to:

$$P_{mot} = 1000 \frac{W}{m^2} \cdot 0,845 \text{ m}^2 \cdot 0,30 + 1000 \frac{W}{m^2} \cdot 7,074 \text{ m}^2 \cdot 0,245 = 1986,63 \text{ W}$$

Because the motor has an efficiency of 95% and the controller has an efficiency of 99% the power afterwards becomes:

$$\begin{aligned} P_{mot 2} &= 1986,63 \text{ W} \cdot 0,95 = 1887,29 \text{ W} \\ P_{contr} &= 1887,29 \text{ W} \cdot 0,99 = 1868,43 \text{ W} \end{aligned}$$

In the Umicar there is no transmission because the motor is installed into the front wheel. So there are no losses due to transmission. There still are losses due to rolling resistance and air resistance. These two losses are caused by the speed and can be calculated by:

Rolling resistance:

$$P = v \cdot F_r = v \cdot C_{rr} \cdot N_f$$



Air resistance:

$$P = v \cdot F_w = \frac{\rho \cdot v^3 \cdot C_d \cdot A}{2}$$

C_{rr} is the rolling resistance coefficient, N_f is the normal force, ρ is the density of air, C_d is the friction coefficient of the air resistance, A is the frontal surface, v is the speed of the Umicar. Only the speed is unknown:

$$C_{rr} = 0,0056$$

$$N_f = m \cdot g = (225+80) \text{ kg} \cdot 9,81 \frac{\text{m}}{\text{s}^2} = 2992 \text{ N}$$

$$\rho^1 = 1,205 \frac{\text{kg}}{\text{m}^3}$$

$$C_d = 0,077$$

$$A = 0,81 \text{ m}^2$$

When top speed is reached all the power is used because otherwise there would still be power to accelerate. This means that the top speed can be calculated from the previous formulas:

$$1868,43 \text{ W} - v_{top} \cdot 0,0056 \cdot 2992 \text{ N} - v_{top}^3 \cdot 1,205 \frac{\text{kg}}{\text{m}^3} \cdot 0,077 \cdot 0,81 \text{ m}^2 \cdot \frac{1}{2} = 0$$

$$v_{top} = 32,75 \frac{\text{m}}{\text{s}} = 117,9 \frac{\text{km}}{\text{h}}$$

With this speed we can calculate the losses due to rolling resistance:

$$P = v_{top} \cdot F_r = v_{top} \cdot C_{rr} \cdot N_f = 32,75 \cdot 0,0056 \cdot 2992 \text{ N} = 548,73 \text{ W}$$

And power lost due to air resistance:

$$P = v_{top} \cdot F_w = \frac{\rho \cdot v^3 \cdot C \cdot d \cdot A}{2} = \frac{1,205 \cdot 32,75^3 \cdot 0,077 \cdot 0,81}{2} = 1319,98 \text{ W}$$

¹ We calculated the density of the air with the ideal gas formula: $\rho = \frac{P}{R \cdot T}$ with $P = 1 \text{ atm}$ and $T = 20^\circ \text{ Celsius}$ and $R = 287 \frac{\text{J}}{\text{kg} \cdot \text{K}}$

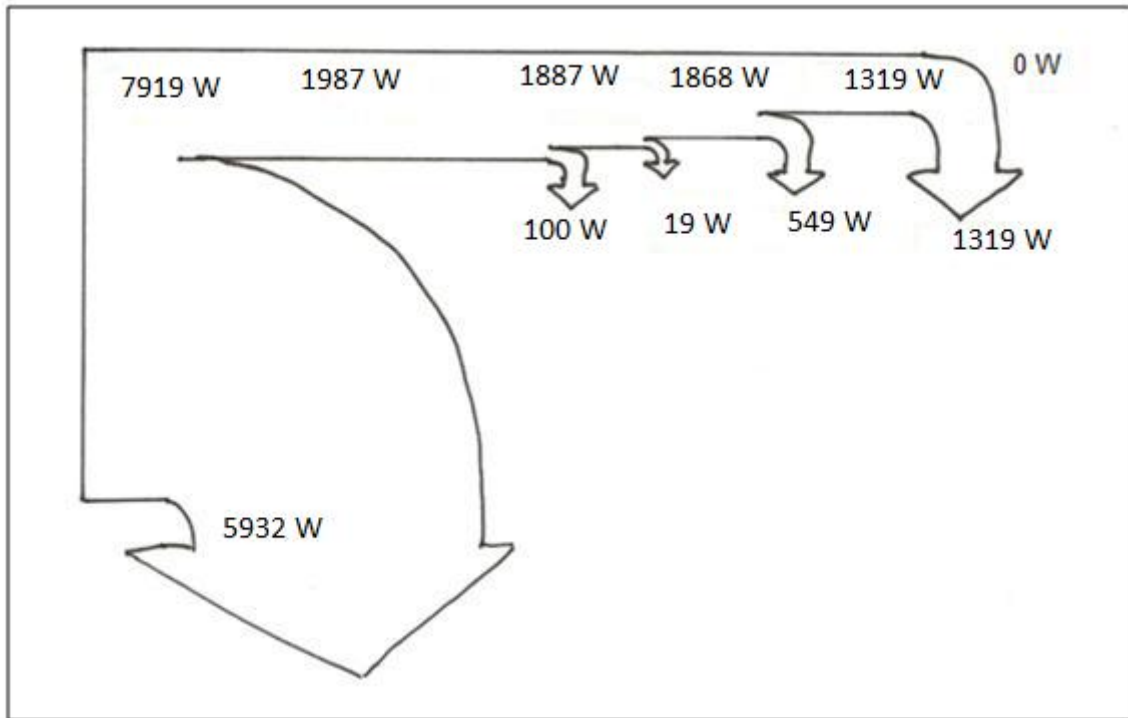

Figure 3 Sankey Diagram at top speed

2. HALF SPEED

The first part of the Sankey-diagram is the same. The only thing that changes is the power lost due rolling and air resistance, because these are the only factors that depend on the speed. Therefore there will still be some power left to accelerate.

This means that there still is 1868,43 W delivered by the motor to the wheel.

The speed is:

$$V_{half} = \frac{V_{top}}{2} = 16,375 \frac{m}{s} = 58,95 \frac{km}{h}$$

This means that the power lost due to air and rolling resistance becomes:

$$P = v \cdot F_r = v \cdot C_{rr} \cdot N_f = 16,375 \cdot 0,0056 \cdot 2992 = 274,37 W$$

$$P = v \cdot F_w = \frac{\rho \cdot v^3 \cdot C_d \cdot A}{2} = \frac{1,205 \cdot 16,375^3 \cdot 0,077 \cdot 0,81}{2} = 164,99 W$$

The power still left at this point is equal to:

$$P_{end} = 1868,43 W - 274,37 W - 164,99 W = 1429,07 W$$

This power can be used for acceleration to reach top speed.

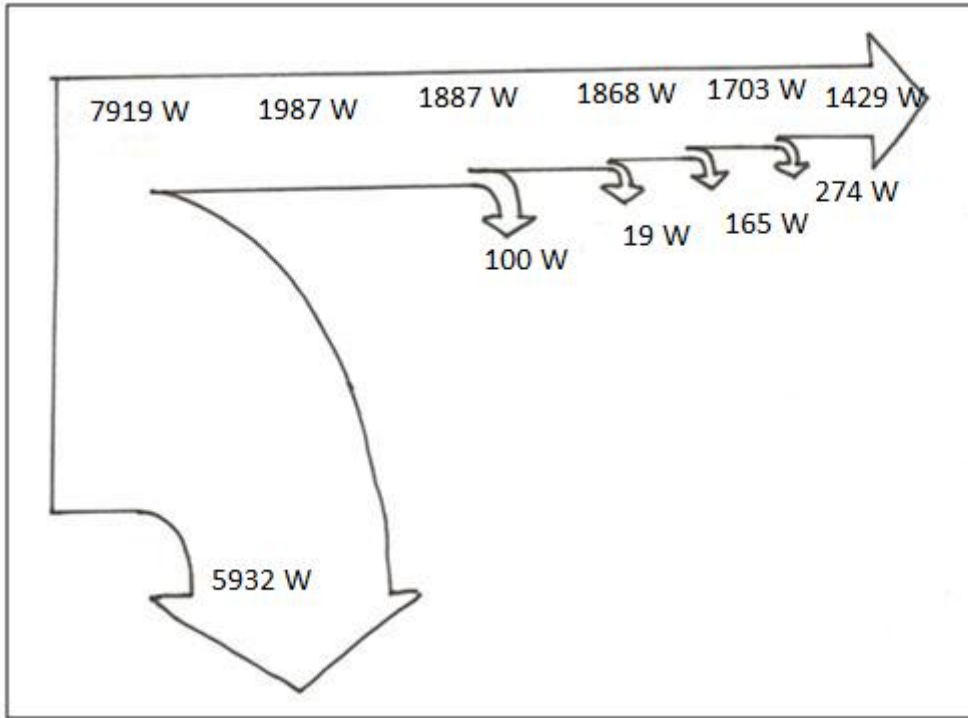
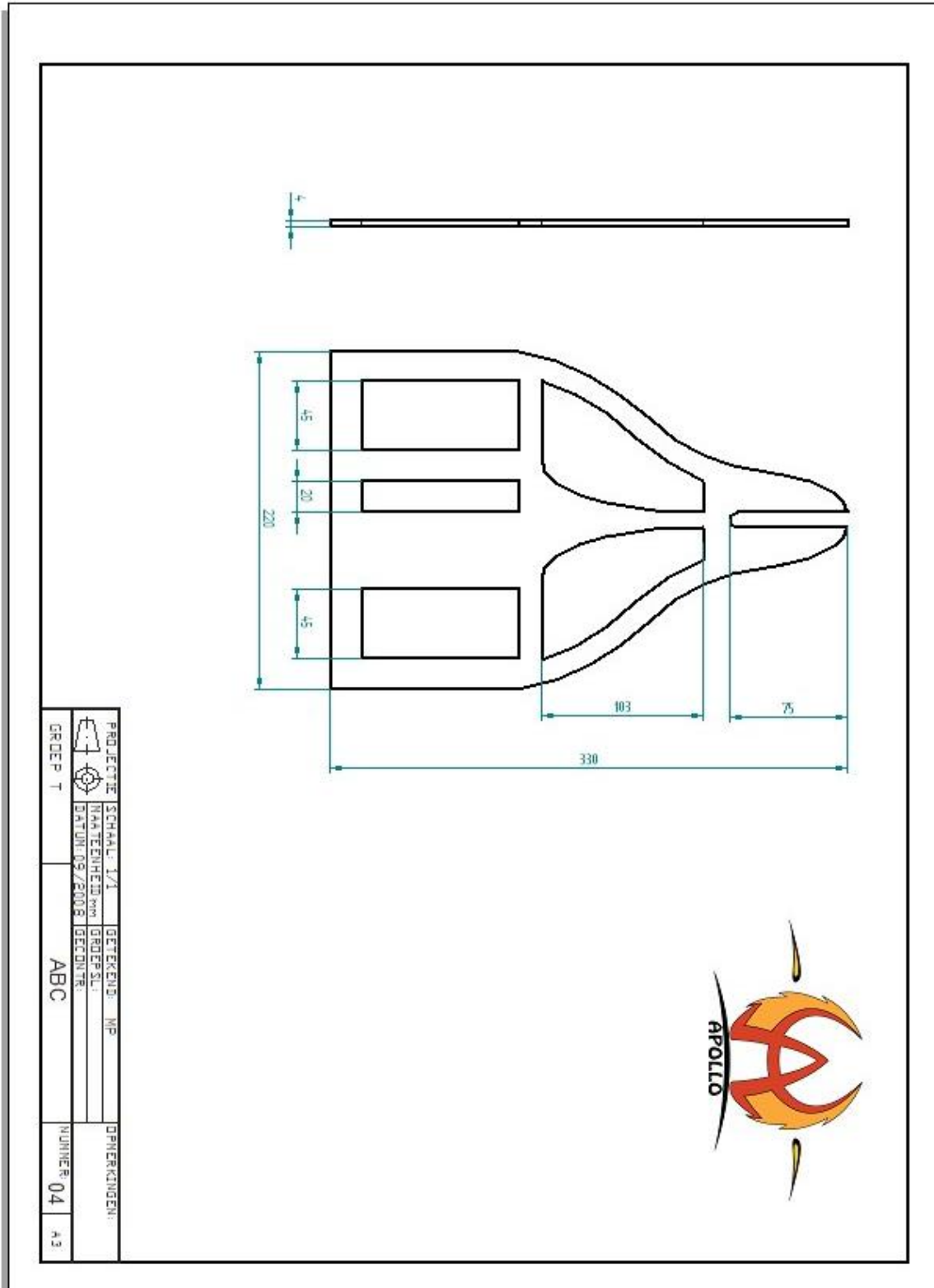
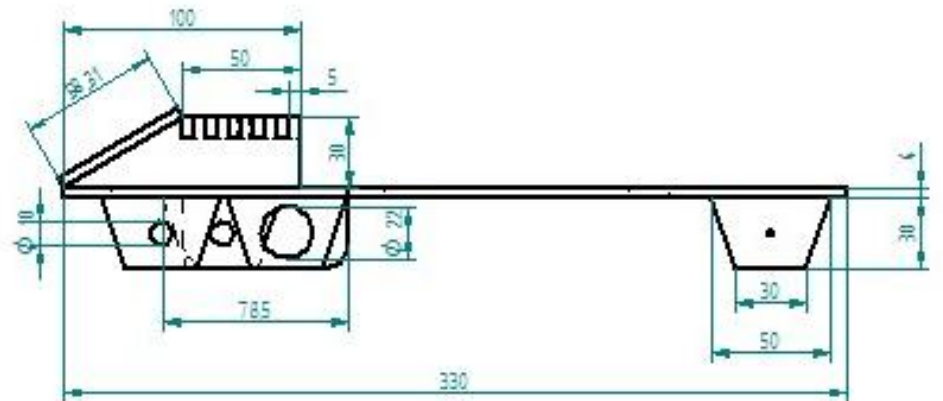
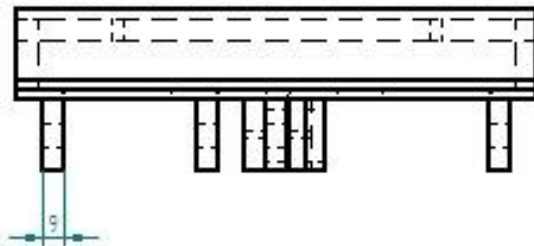
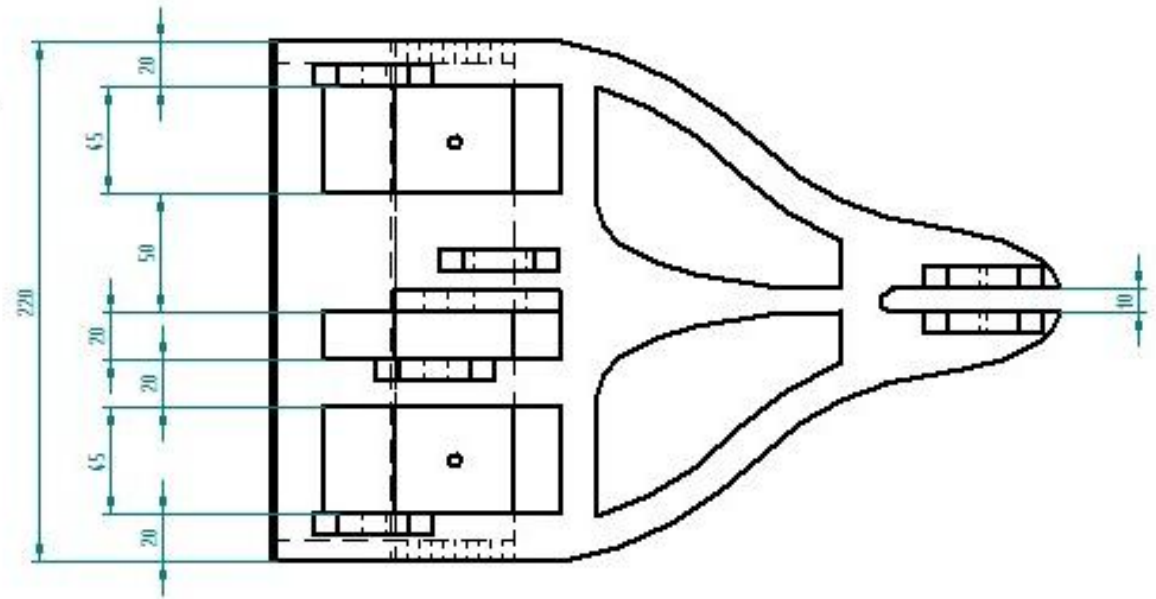

Figure 4 Sankey Diagram at half speed

4. 2D TECHNICAL DRAWING

In this part, you can see the technical drawings of our SSV. We put three versions in this report. The first one is just a drawing of the frame itself, the next version contains extra elements for the wheels, the solar panel, the driven shaft. The last drawing is a technical drawing of our whole SSV with gears, motors and shafts.





PROJECTIE	SCHAAL: 1/1	GETEKEND: MP	OPMERKINGEN:
	MAATEENHEID: mm	GRDEP: SLI	
	DATUM: 09/2008	GECONTR:	
GRDEP: T	ABC		NUNNER: 04 A3

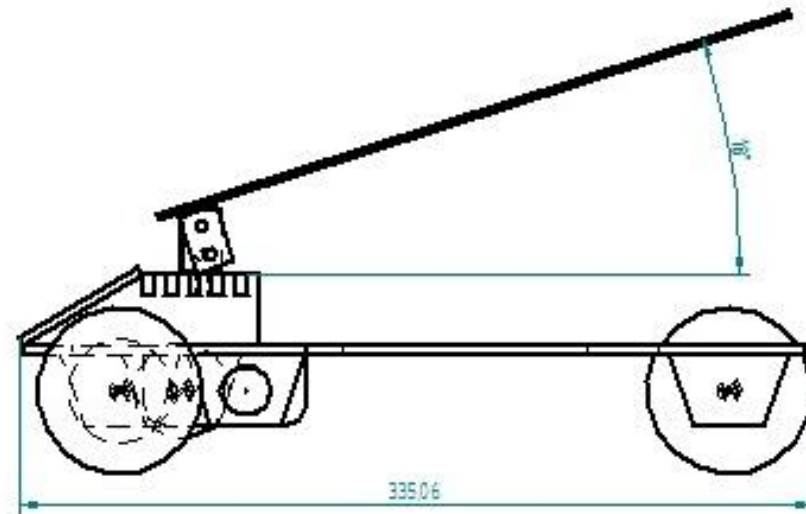
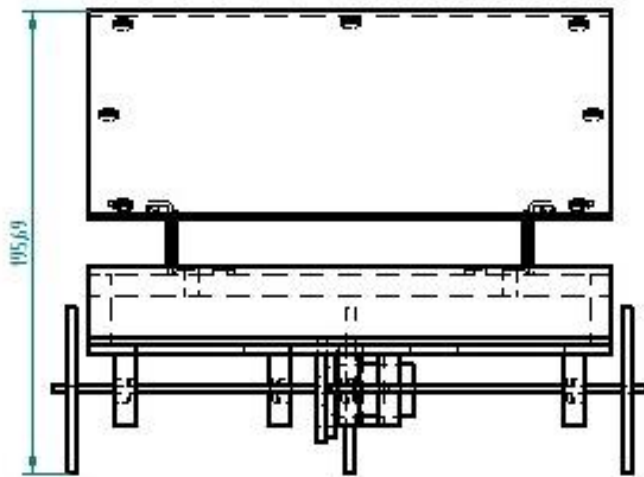
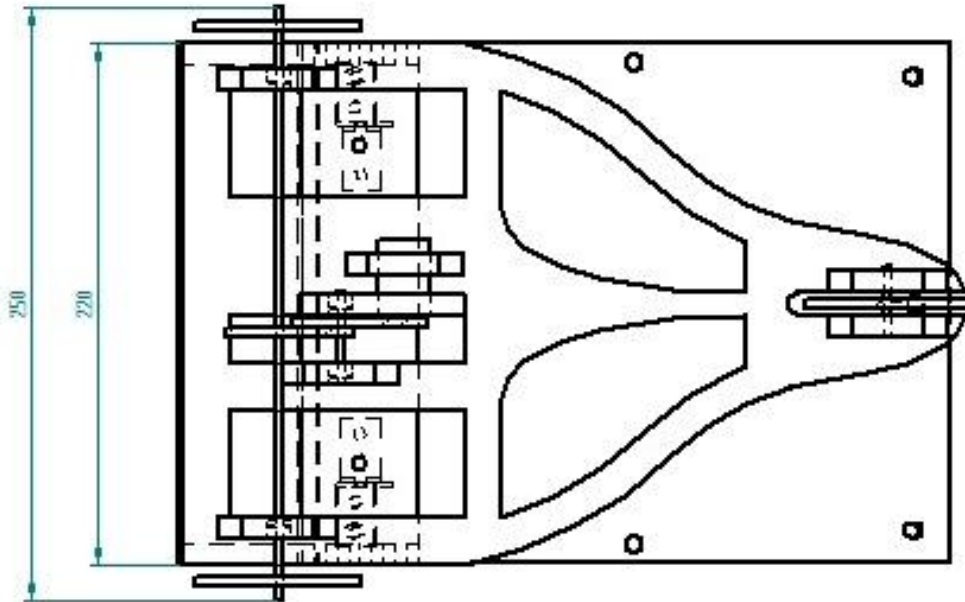

PROJECTIE	SCHAAL: 1/1	GETEKEND: MP	OPMERKINGEN:	
	MAATENHEID mm	GREP SL:		
	DATUM: 09/2008	GECONTR.:		
GREP T	ABC		NUMMER: 04	A3

APPENDIX

In this appendix you can find the Solid Edge drawings and an isometric drawing of our SSV.

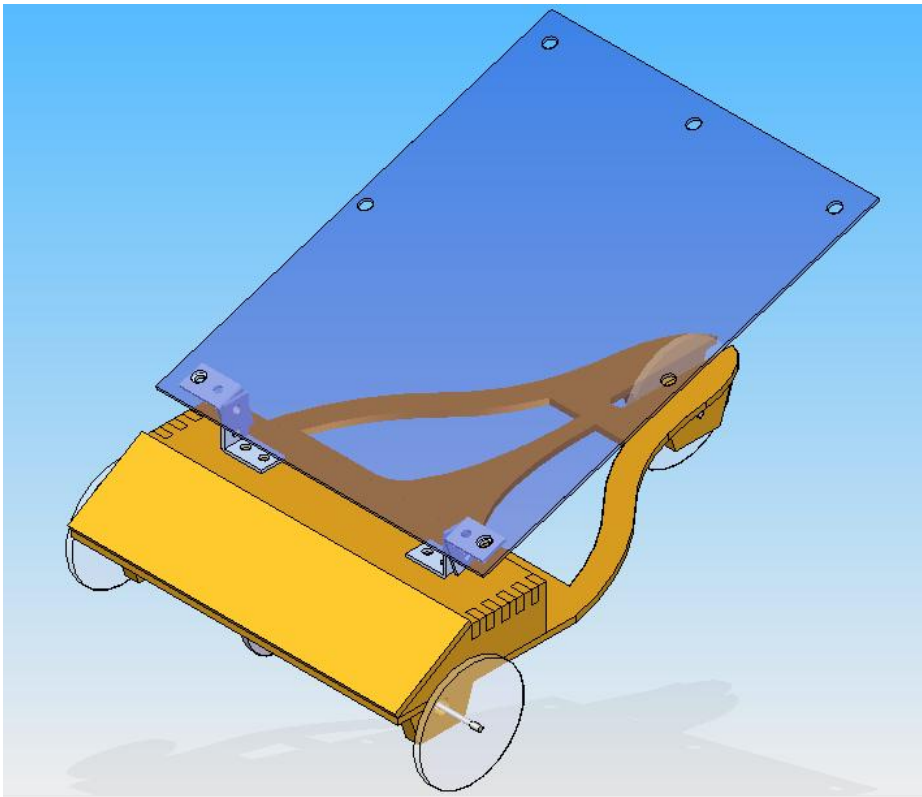

Figure 5 Solid Edge Drawing

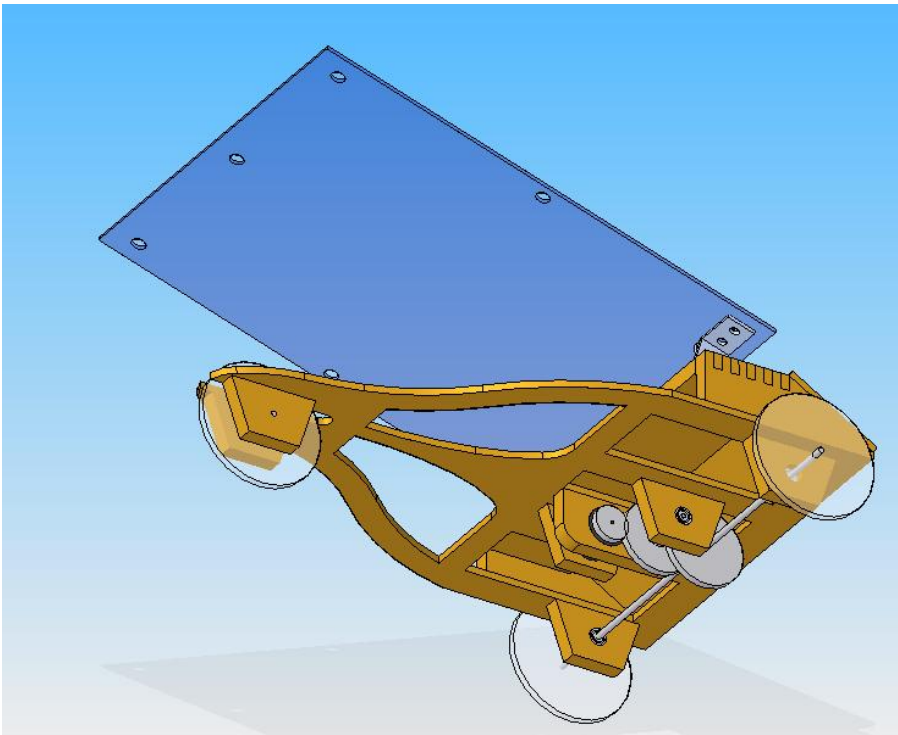
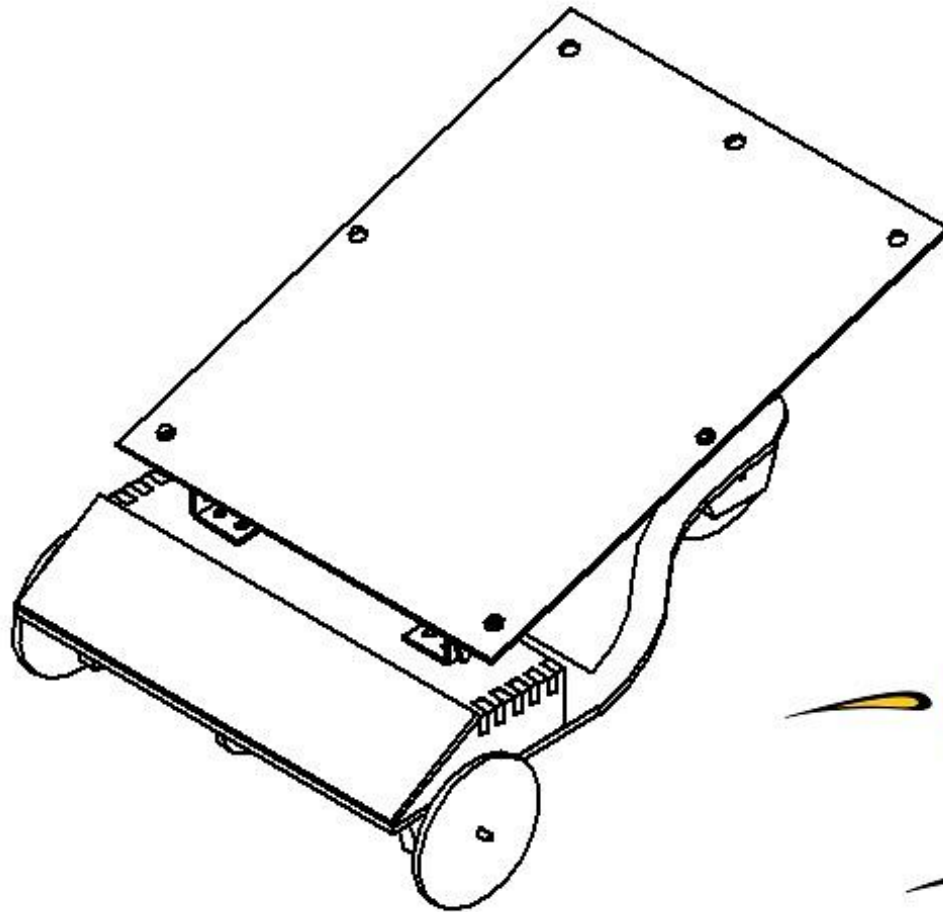

Figure 6 Solid Edge Drawing



PROJECTIE	SCHAAL: 1/1	GETEKEND: MP	OPMERKINGEN:
	MAATEENHEID mm	GRDEP SL:	
	DATUM: 09/2008	GECONTR:	
GRDEP T		ABC	NUMMER: 04 A3