

Capacitor

Copyright (c) 2011 Young W. Lim.

Permission is granted to copy, distribute and/or modify this document under the terms of the GNU Free Documentation License, Version 1.2 or any later version published by the Free Software Foundation; with no Invariant Sections, no Front-Cover Texts, and no Back-Cover Texts. A copy of the license is included in the section entitled "GNU Free Documentation License".

Please send corrections (or suggestions) to youngwlim@hotmail.com.

This document was produced by using OpenOffice and Octave.

Charge

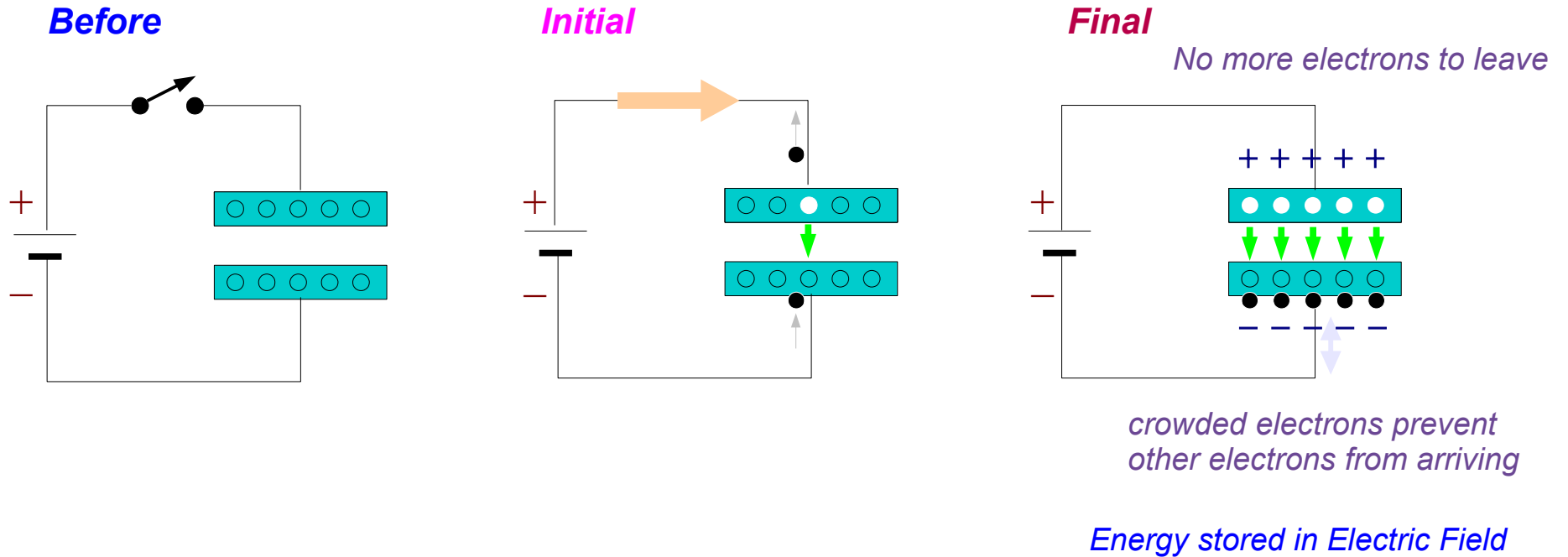

Discharge

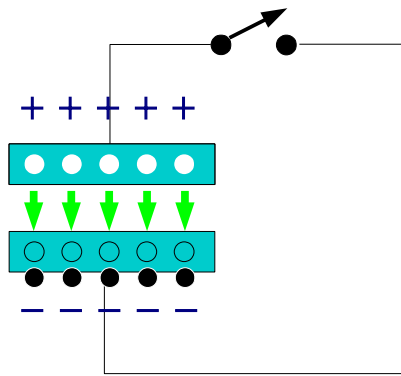

Initial

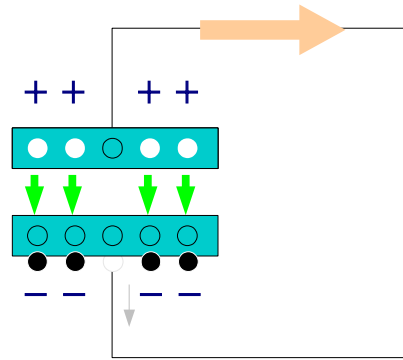

Final

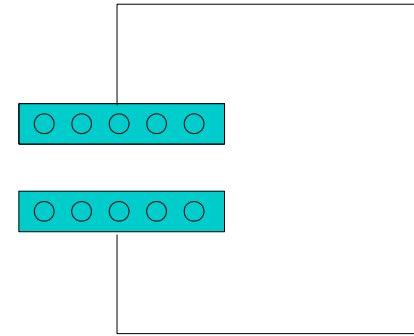

No more electrons moving

Charge

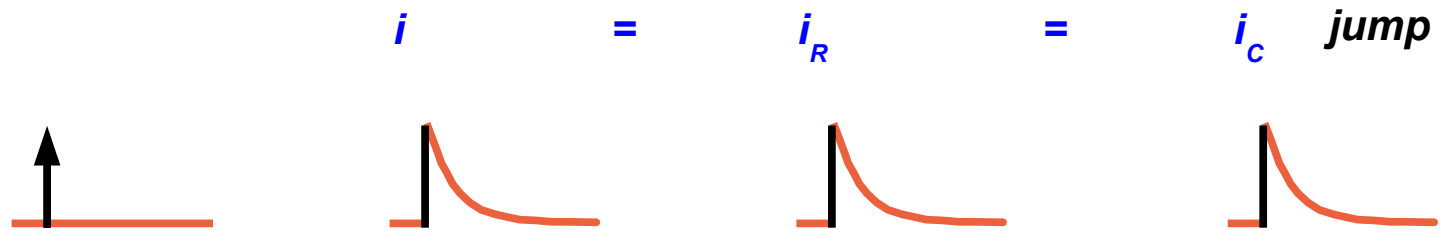
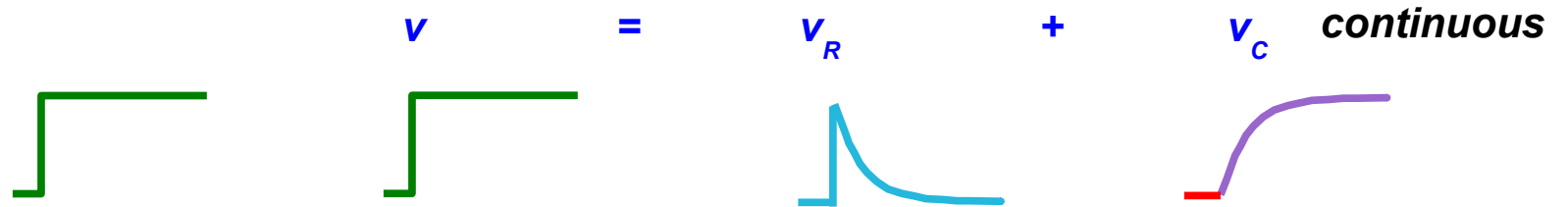

$$i_c = C \cdot \frac{dv_c}{dt}$$

Discharge

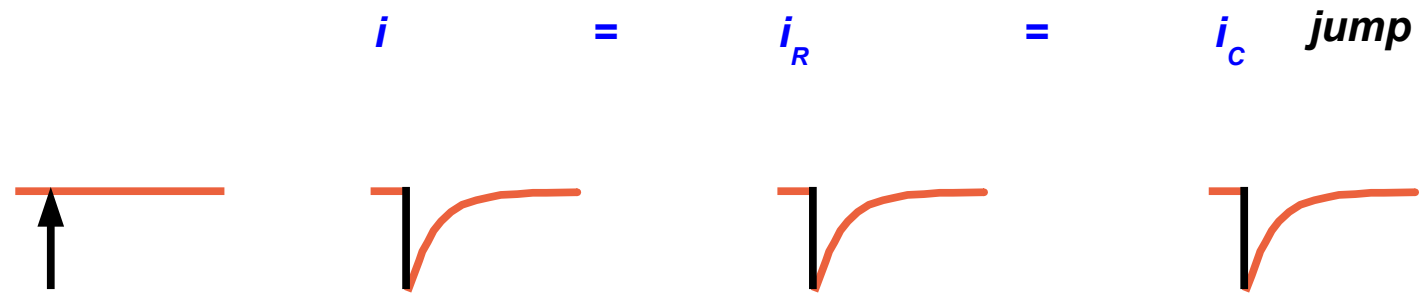
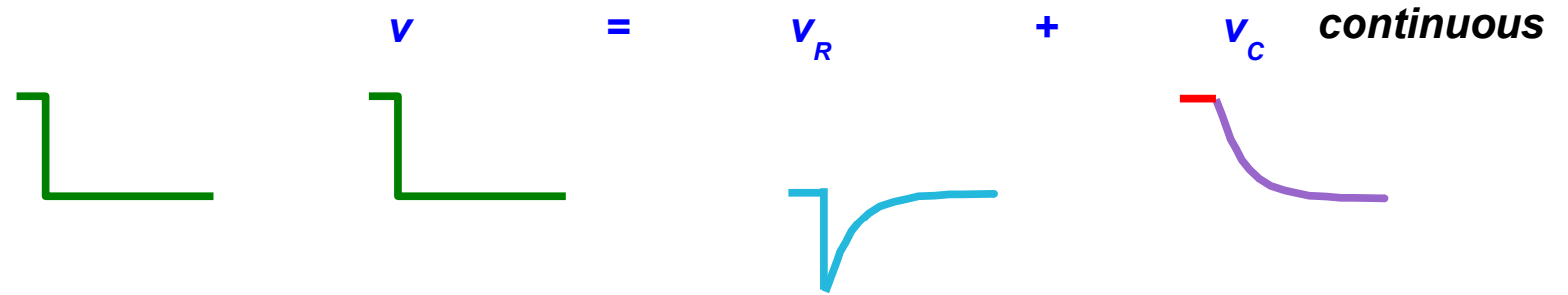

$$i_c = C \cdot \frac{dv_c}{dt}$$

Pulse

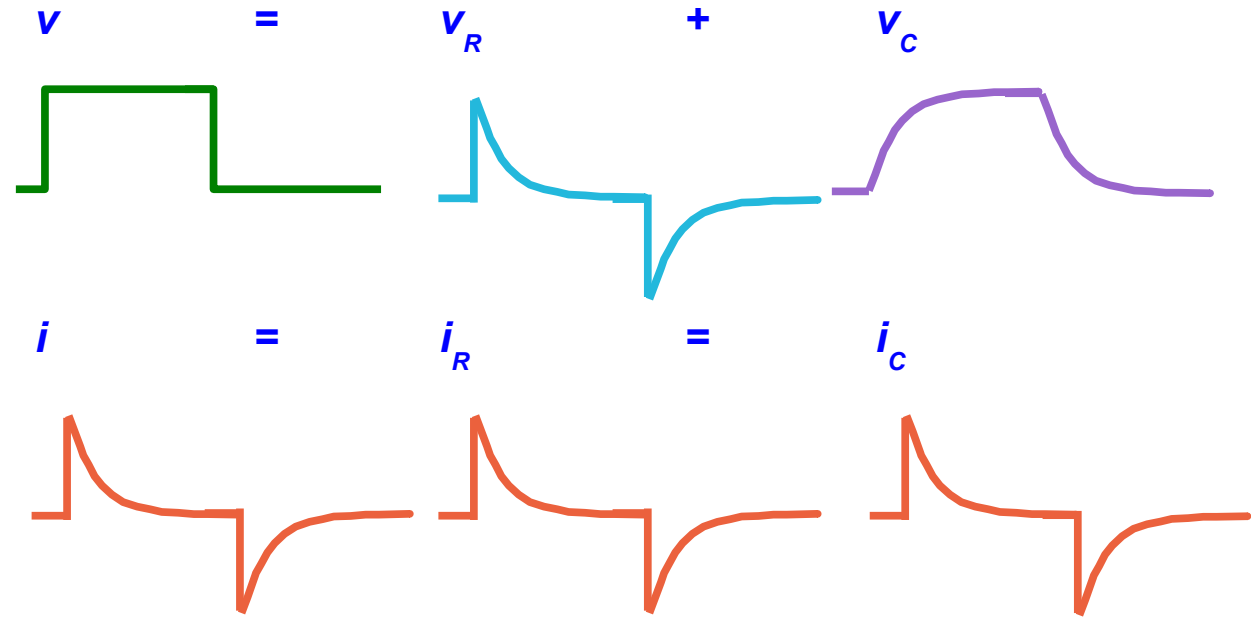

Pulse

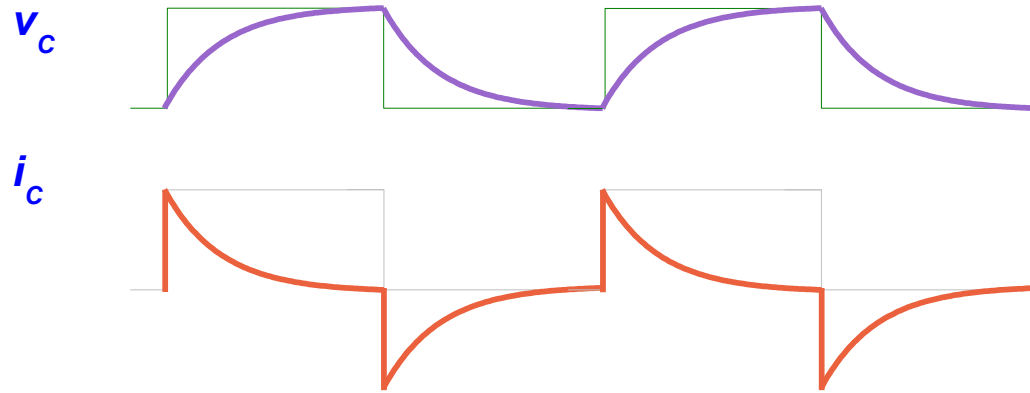

$$i_c = C \frac{dv_c}{dt}$$

ω ↑ i_c ↑ X_c ↓

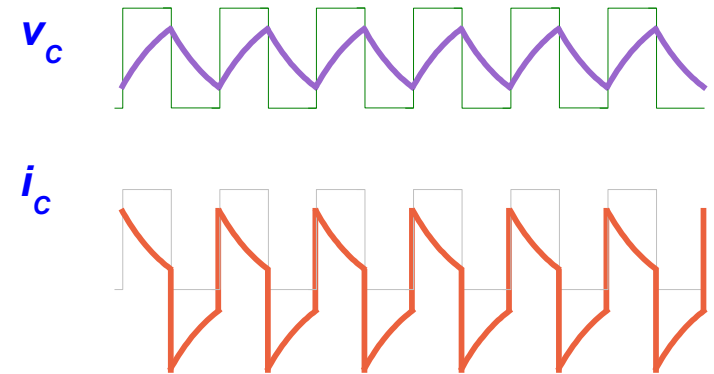
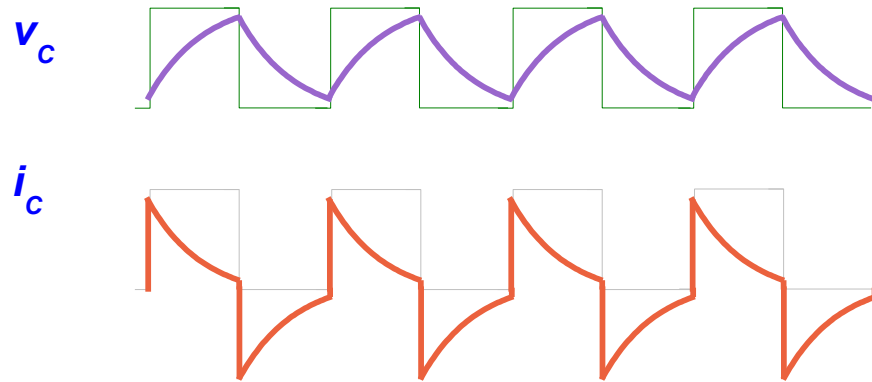

Phase Lags and Leads

References

[1] <http://en.wikipedia.org/>

[2] J.H. McClellan, et al., Signal Processing First, Pearson Prentice Hall, 2003