

Scientific American.

THE ADVOCATE OF INDUSTRY, AND JOURNAL OF SCIENTIFIC, MECHANICAL AND OTHER IMPROVEMENTS.

Vol. 4.

New York, February 3, 1849.

No. 20.

THE
SCIENTIFIC AMERICAN :
CIRCULATION 11,500.

PUBLISHED WEEKLY.
At 123 Fulton Street, New York (Sun Building,) and
13 Court Street, Boston, Mass.

By Munn & Company.

The Principal Office being at New York.

TERMS—\$2 a year—\$1 in advance, and
the remainder in 6 months.

See advertisement on last page.

Poetry.

THE ROYAL PEDIGREE.

Let those who will claim gentle birth,
And take their pride in Norman blood,
The purest ancestry on earth
Must find its spring in Adam's mud ;
And all, though noble now or base,
From the same level took their rise,
And, side by side, in loving grace,
Leaped, crystal-clear, from Paradise.

We are no spawn of bartered love,
That's welded to the heart with gold,
Put on as lightly as a glove,
As lightly doffed, scarce three days old—
A love that marries lands to lauds,
The passion of two title deeds,
That loosely rivets two cold hands,
And idler heirs to idlers breeds.

Large-limbed, the friend of sun and air,
Its sinewy arms with labor brown,
With glad, strong soul, that seemed to wear
Its human nature like a crown—
Such was the love from which we sprang,
A love clear-hearted as the morn,
Which through life's toils and troubles sang
Like a tall reaper 'mid the corn.

Life lay before us hard and broad,
To conquer with two hands alone—
But we had faith in man and God,
And proudly claimed our Father's throne ;
We made our vassal of the Now,
And, from its want and woe and wrong,
Our hearts rose highly as a bough
From which a bird had soared in song.

Among our sires no high-born chief
Freckled his hands with peasant-gore,
No spurred and coronetted thief
Set his mailed heel upon the poor ;
No, we are come of nobler line,
With larger heart within the breast,
Large heart by suffering made divine—
We drew our lineage from the Oppressed :

There's not a great soul gone before
That is not numbered in our clan,
Who, when the world took side with power,
Stood boldly on the side of Man :
All hero-spirits, plain and grand,
That for the Ages open'd the door,
All Labor's dusty monarchs, stand
Among the children of the poor.

Let others boast of ancestors
Who handed down some idle right
To stand beside their tyrant's horse,
Or buckle his spurs before the fight ;
We, too, have our ancestral claim
Of marching ever in the van,
Of giving ourselves to steel and flame,
Where aught's to be achieved for man.

And is not this a family-tree
Worth keeping fair from age to age ?
Was ever such an ancestry
Gold-blazoned on the herald's page ?
In dear New-England let us still
Maintain our race and title pure.
The men and women of heart and will,
The monarchs who endure.

THE FRENCH SEWING MACHINE.—Figure 1.

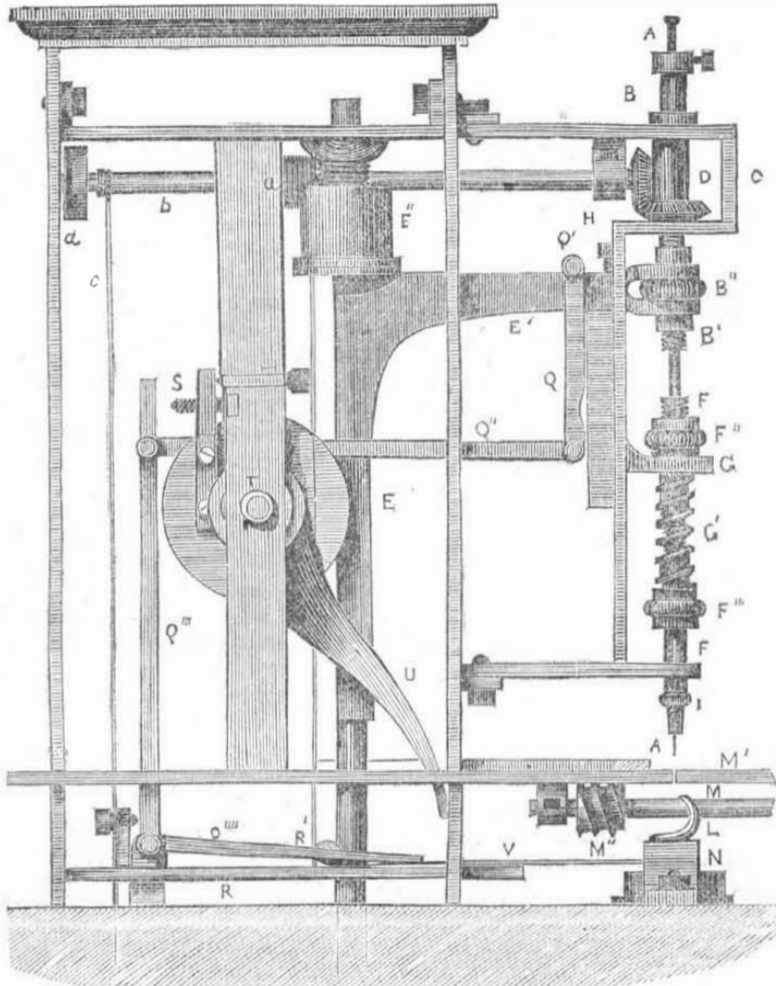

This machine is the invention of a French gentleman named Jean Marie Magnin, and which was first published in the London Patent Journal. It will be found, as we stated in our last, that it is not so simple as the American Sewing Machine, although it performs well and does good work. It plaits cord, so does the American machine, but it does not move the cloth to be sewed, an attendant has to do this. Fig. 1 is a side elevation showing the principal parts and movements, and fig. 2 a sectional elevation of the-nipple, needle and thread carrier on an enlarged scale. A, is the needle stem passing through and secured to the spindle B B1, by a set screw. B B1, is free to have a vertical motion and it passes through bushes C, and the elongated boss of the lower at two bevelled wheels D. The lower part of B, has a thread cut upon its exterior surface to receive the nut B2, for the purpose of regulating the stitch or loops.—

FIG. 2.

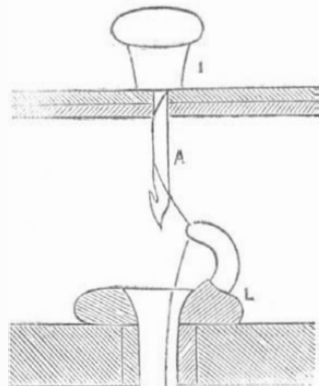

The boss upon the middle of the nut B3, which passes through the fork of the arm E1, which springs from the vertical rod E, passing thro' a bush downwards and attached to a treddle at the lower part of the frame. The bush E2, is so constructed that by means of a screw, the position of the lower part is capable of being adjusted higher or lower whereby the rise of rod E is governed, and thus regulates the descent

on an upper shaft b. When R is drawn back by U, a rotary motion is given to the spindle of L, just sufficient to make one revolution of the thread carrier, by which the thread is laid round the needle as it projects through the cloth, and when R is released from this position the spiral spring on the spindle of the thread carrier by its elastic force returns L, to its former position, which is the tambouring stitch exactly. This sewing machine however, can give a rotary motion to the needle by the bevel gearing D above, acted upon by the cord c and spring d moving the spindle by the bevel gear round, just so many teeth at once as the operator desires, when working the machine.

This operation of sewing is exactly like tambouring by machinery and it can embroider in a very beautiful manner, but for seam sewing we should not prefer it. One of these machines however, has been made with a number of needles and operates well. The agents of it in London are Messrs. Barlow and Payne 89 Chancery Lane.

RAILROAD NEWS.

It is reported that the Hartford and New-Haven and New-York and New-Haven Railroads are likely to effect a compromise, by which a joint line of travel over the two Railroads will be immediately established. The branch for connecting the two Railroads is already completed, so that there is no physical impediments to the running of cars from Boston to New-York. We understand that a negotiation is now pending for the arrangement of the details for running a daily passenger train through on this line between the two cities, which we doubt not will be carried into effect without delay.

Indianapolis Railroad.

The Madison and Indianapolis Railroad Co. have declared a dividend of 6 per cent for the last five months, equal to 14 per cent per annum, payable to stockholders here at the office of Winslow, Lanier & Co. Wall st.

The Panama Railroad.

The Engineering Expedition fitted out by Messrs. Aspinwall, Chauncey & Stephens, for the survey and location of the Panama Railroad, sailed on Tuesday week for Chagres, in the bark Templeton. The expedition consists of the following persons :—

Chagres Division.—Wm. Norris, Principal Engineer. 1st Assistants—John May and E. W. Serrell. 2d Assistants—George Wolcott and George Stoddard.

Panama Division.—W. H. Sidell, Principal Engineer. 1st Assistants—Capt. Lloyd Tilghman and J. L. Baldwin. 2d Assistants—J. H. Manderville and J. Williams.

Surgeon to the Expedition—Dr. M. B. Halstead.

Mr. Sidell sails in the Falcon on Feb. 5, until which time his division will be in charge of Capt. Tilghman. The expedition has been fitted up with much pains and expense, and from the character of the gentlemen engaged in it, there is no doubt but that the survey will be thoroughly and speedily performed.

California Railroad.

It is calculated that a railroad from the Junction of the Nebraska and Missouri rivers to San Francisco, would be no more than 1600 miles long and that it might be constructed for \$20,000,000.

Telegraph Lines.

The new line of Telegraph between Washington, Baltimore and Philadelphia, commenced by a company of Baltimore and New York capitalists, will be completed in the Spring. The Boston line, which will afterwards be continued to Halifax, will be in working order about the first of June. The line to Buffalo will also be speedily constructed. Upon these lines the telegraph of Mr. Bain will be used.

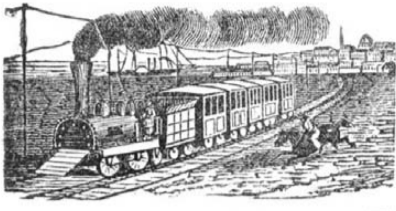
**Our Prize Essay.**

We are pleased to see the general attention attracted by our offer of one hundred dollars for an Essay on the Patent Laws of the United States. This is a work which will not only be of benefit to the author in a pecuniary point of view, but one which will add greatly to the reputation of the successful competitor.

The artists and inventors of this country are particularly interested in this matter and the revision of the Patent Laws is to them not only necessary but demanded from the present imperfect operation of these laws, and while we would urge upon those competent to the performance of the work of preparing this essay a careful study of the law as it is now compiled we would also suggest the most thorough preparation of a code which shall be comprehensive, full, and complete, and so arranged that there be no loop holes by which the real inventor may be deprived of the benefit accruing from the embodiment of his genius upon machinery or other successful inventions.

It has ever been a source of regret to the true friends of the inventor that unprincipled men have in some instances derived all the benefits resulting from the inventions of others, who from a want of the means of perfecting their works have been obliged to sacrifice them and thereby enabled capitalists to amass fortunes, and the cases are not of rare occurrence in which the productions of genius have been unjustly appropriated without consideration, fee, or reward.

To meet these exigencies some measures should be devised and we particularly direct attention to such alterations as shall cover the entire surface of the wants of inventors. That such revision of the laws is much needed does not admit of a doubt and when the work is commenced it were better it should be thorough and effective rather than it should have to be again amended.

We are not prepared to say how far or upon what points the present laws are defective but that they may be greatly improved we know and to facilitate a labor of such importance to those who are to be benefited by them is the inducement of our offer for the essay.

Patent Case.

A verdict has been rendered in the U. S. Circuit Court at Boston, for the infringement of a patent for a Railroad Car Wheel, in favor of W. V. Many, of Albany, N. Y. against Mr. J. Sizer, of Springfield, Mass. Both parties had patents, but the defendant's was considered an infringement on the original one. The verdict rendered is a heavy one, \$81,718 68—not paid, however,—the case goes up to the Supreme Court as it should, although we do not like the position assumed by the defence—finding fault with the specification, a lawyer's we believe, but a very good one.

The Great Telegraph Case.

The great Telegraph case between Morse & Co. and O'Reilly & Co., an application for injunction on the O'Reilly line through Tennessee (from Louisville to New-Orleans,) as an infringement of Morse's Patent is now before the Supreme Court of the U. S. at Washington. The Counsel for Morse & Co. are W. H. Seward, Ex-Governor, N. Y. and P. S. Loughborough, Ky., and for O'Reilly & Co. Hon. Ransom H. Gillett.

Since the above was written Judge Catron has decided against Morse & Co. and in favor of O'Reilly & Co.,—the injunction of Judge Munroe will thus be removed we suppose.

Homestead Exemption.

They are talking about the passage of a law for the exemption of the homestead in Missouri to the value of five hundred dollars. The policy of many States of the confederacy seems now to be in favor of allowing the hard working man of small means to hold inviolate a sufficient amount of property to supply the pressing wants of his family.

LITERARY NOTICES.

It is truly astonishing what mighty results have been accomplished by the introduction of the water cure system. It exceeds the once popular notions of Graham's system of dietetics, aside from the prejudices that seem to exist in many minds against the increasing popularity of this system. All acknowledge the beneficial effect of daily bathing, it increases the action of the physical powers by allowing all unhealthy collections to escape through the pores of the body.

Messrs. Fowlers and Wells of this city are now engaged in publishing a monthly Water Cure Journal at \$1 per year, which "Shews" more light upon the subject than any thing within our knowledge. It is worth a careful study.

Morfit's Chemical and Pharmaceutical Manipulator.

This is a beautiful volume and as useful as beautiful, just issued from the press of Lindsay & Blakeston, publishers, Philadelphia.—It is edited by Campbell Morfit, the well known and able chemist and author of "Applied Chemistry," assisted by Alex. Muckle, an excellent chemist also. This a rare work and one that was just wanting to fill up a gap in the chemical student's library. It is a book of near 500 pages with 423 beautiful engravings. It is a minute Directory of the Laboratory describing all the apparatus, the manner of using them and conducting experiments so particularly, that "he who runneth may read." There is not a chemical student, nor school in this country that would be without this work a day if they but knew its really useful and practical nature. It is for sale by the publishers Philadelphia, and by Geo. P. Putnam, 155 Broadway this city.

American Phrenological Journal.

This able Journal for February contains a likeness of Andrew Combe, the celebrated Scotch Phrenologist, with a descriptive account of his organization, &c. and a short biography. It is an excellent number.

The February number of the You'h's Cabinet, published by D. A. Woodworth, New York, at \$1 per year, has appeared upon our table, and is a pleasant companion for our youthful readers. It is worthy the attention of parents.

American Pencils.

At the last Exhibition of the Franklin Institute, a medal was awarded to Mr. A. G. Fay, of Concord, Mass., for an improvement in the form and material of the common crayon or lead pencil. They are made of various sizes and forms, one of which is a flat oval, which prevents the pencil from rolling from a desk of the ordinary inclination and the lead may be cut, shaped and worked without liability to break or crumble. For common purposes, the American pencils of Mr. Fay have no superior. We have tried them and find them to be good.

Separation of Iron from the ore by permanent Magnets.

Mr. A. Wilkinson of R. I., has invented a new way of applying permanent magnets on a revolving cylinder to separate the iron from the ore. One of Mr. Wilkinson's machines is in successful operation, as he informed us in Charlottenburg, N. J., with great profit. It is well known that ores have been separated by electro magnets—the circuit closed to attract the iron,—and broken to remove the iron from the magnets. This however, is the first permanent magnet ore machine that has been successful or used at all—to our knowledge. The ore is brushed from the magnets by brushes while the cylinder is moving. The economy of this magnetic machine is apparent. The magnets are cheaper than the electro kinds—no battery is required, and the machine is more simple. Measures have been taken to secure a patent.

Disasters on the Western Rivers.

According to the St. Louis Union, the total number of steamboats which have met with disasters on the Western Rivers during the past year is 109. Of this number 59 were totally lost. By the various accidents 205 lives were lost. No estimate is attempted of the loss of property. On 14 of the boats \$118,800 were insured.

Westwardly Current along the North Shore of Cuba.

The Washington Union, speaking of Lieut. Maury's wind and chart current, says:

We observe by the letter of Lieut Maury to the New England whalemens, that he has been led to suspect the existence of a westwardly current of from two to three miles the hour along the north shore of Cuba, and that the usual route of the sailing vessels from the Havana to New Orleans, and other Gulf ports, is for much of the way. The average rate of sail vessels is not more, we are told, than five miles the hour, and the difference which this newly discovered current would make is five miles for two-thirds the distance to New Orleans.

Our Ship owners and merchants are praying to have this current thoroughly examined and reported on by the vessels of the Gulf Squadron. This they could do without the least inconvenience or expense; for it would be only necessary for them to place themselves, when cruising about the Gulf, within the influence of this current.

Children Born Blind.

There is a court in Boston called "Limeric Place" which is about 80 feet long and the buildings are erected upon ground 50 feet wide with a 12 foot passage way taken off. The narrow opening is bounded on each side by a four story brick building divided into 28 tenements occupied by a miserable and poor population. A short time ago the Rev. Theodore Parker declared that "all the children born there were blind." This statement has been found to be incorrect in part, only. Most of the children are diseased and no wonder. In these United States, no city should allow such places to be inhabited by human beings. We want our country in every sense to be the abode of comfort, cleanliness and liberty, and when there is any portion of our citizens, or strangers that do not conform to wise and just regulations, why we must make them do it by the strong arm of law. Light, ventilation, and cleanliness are just as necessary to sustain life as food and water. The want of the former may take more time to complete the work of destruction, but the result is no less certain on that account.

Remington Again.

The sympathies of our people were very much excited some months ago by a letter from Mr. Remington, an ingenious American in England, to the late Hon. Dixon H. Lewis, which went the rounds. Mr. Tyler, the proprietor of the Surrey Gardens, London, has come out in the London papers, and denied that portion of Mr. Remington's statement, in which he says that, during the time he was erecting the bridge, he slept in a lion's deserted cage, and depended upon the charity of the carpenters for his dinner.

Mr. T. says he boarded steadily at a Mr. Ladd's, and his board was regularly paid.

A Golden Rock.

A runaway soldier in California discovered a rock of gold that weighed 899 pounds and as he was afraid to leave it, he mounted guard upon it; and at the last account had sat 67 days, and had offered \$27,000 for a plate of beans and pork, but his offer had always been indignantly refused, and the poor fellow only laughed at, for the niggardliness of his offer, by parties going on, where the article was said to be more abundant.

Tunnelling the Alps.

The Gazette de France says that the engineer Mans, commenced operations with his machine perforating a rock to the thickness of 48½ centimetres in thirty five minutes. If this process was applied to the perforation of Mount Cenis, it is calculated that by working at the two opposite ends three years would be sufficient to complete the work, thus opening a free intercourse between Italy and the continent.

A Healthy Town.

The Manchester (N. H.) Democrat says that during the first twelve days of the year 1849 there was but a single instance of death in the city of Manchester among a population of 13,000.

Three new powerful engines have been put on the Erie Railroad and the whole motive power of the road put in perfect repair.

New Parliamentary Rule.

It is said that the Ministers of Canada intend to propose that the House of Assembly shall sit for only three days in each week, for the purpose of debating and deciding on the measures brought before it. It is intended that on the other three days the House shall be divided into a number of Committees, who shall consider and prepare all these measures, so that when they come before the whole House, they may be carried with as little trouble and altercation as possible. We think the plan a very sensible one.

Death by Anthracite Coal Gas.

An old man named Thomas Fitzpatrick recently lost his life from the effects of Anthracite Coal gas, inhaled by him during night. His son was likewise affected by it, but is in a fair way of recovery.

It seems that before going to bed, they made up a fire and turned the damper of the stove, so that in a short time thereafter the fumes must have spread through their apartment and rendered them unconscious.

Queen Ann's Farthing.

It is reported that Mr. A. C. Davis, of Flemington, N. J. has discovered a relic, being nothing less than a Queen Ann's farthing, in a copper mine which was opened a short time ago after being closed one hundred and forty five years. This is the first time we have heard of four Queen Ann's farthings. There were only three cast, and there must certainly be some mistake about this one. Jarsey beats all for ancient discoveries.

It has been eloquently and truly said, that if Christianity were compelled to flee from the mansions of the great, the academies of philosophers, the halls of legislators, or the throngs of busy men, we should find her last retreat with woman at the fireside. Her last audience would be the children gathering around the knees of a mother; her last sacrifice, the secret prayer, escaping in silence from her lips, and heard, perhaps only at the throne of God!

The Thermometer and Winter Items.

At Montreal during the past few weeks the weather has been extremely cold, the thermometer ranging from zero to ten or twelve degrees below. At Boston on Thursday, last week, at 2 P. M. thermometer at 45°. Winter sports are all the go, at Toledo, Ohio. The river is covered with a sheet of smooth ice of 15 inches thickness, which can be traversed by the heaviest-laden teams with perfect safety. The weather continues very cold, and the prospect is fair for the ice to remain for weeks.

Virginia Coal.

In a speech recently made in the Virginia legislature, in favor of a bill to incorporate the Virginia Coal Company, Mr. Faulkner, of Berkeley, stated that the coal fields of that state covered 21,000 square miles out of the total area of 64,000—an extent equal to that of England, Ireland, and Wales combined! Cannel, or purely bituminous coal abounded throughout the basin of the Kanawha; and was so accessible that a single hand could dig with ease two hundred bushels of coal per day.

Trial of Factory Girls.

Seventeen factory operatives were lately tried in Pittsburg, Pa., for rioting, in holding out for the ten hour law. Eight men and five girls were convicted and four acquitted. One of the persons was a little girl 13 years old.

The stock for the Chemung Railroad is all subscribed, and it is believed that it will be completed in time to connect with the New York and Erie Extension at Elmira, in October next.

A bill has passed the New Jersey Legislature incorporating the Newark Orphans' Asylum Association, which is composed entirely of ladies. By a provision of the charter, their husbands are exempt from liability of any results of their management.

An exchange says that machinery for a cotton factory is going out to Francisco Bay, on account of a New England Company.

Doubtful,—if true still a doubtful experiment.

Engraving.

The arts by which representations of objects are given by impression, in one plain colour, on paper, are commonly divided into two, Metal Engraving, and Wood Engraving, and the impressions from the works executed in these arts, are respectively termed plates and cuts. The earliest impression of an engraving on wood, which is known to be in existence, is dated 1423. Still, whatever its rudeness, it was produced by precisely the same process as the beautiful cuts which we now find illustrating books. The wood generally made use of for this purpose is box; the old workmen cut on the length of the wood, the moderns on the cross section. If a work of great finish was required, it was the practice to use two or more blocks. The first merely impressed the outline; another put in the half tints, and so on, until the requisite effect was produced. Some of Albert Durer's engravings were worked by this tedious process. The tools required are four, namely, a graver, a tint tool, a gouge or scooper, and a flat chisel. All the parts of the wood are cut away except those intended to mark the paper, that is, all the lines we see in an impression are caused by elevation on the block. The mode usually pursued is this: the block is made perfectly even on the side on which the engraving is to be executed, and then a little whitening is rubbed over it. The subject is drawn on the block with a pencil by the artist. The cutting then commences, the wood left untouched by the pencil being removed, the cutter pushing his tools from him, whilst the metal engraver pulls them towards him. One of the best effects is caused by the processes called overlaying and lowering. In the former, where lightness of expression is desirable, the surface of the block is scraped away, so that the ink on those parts is only slightly received by the paper. In overlaying, pieces of paper or cloth are placed on the back of the block, and when the pressure is applied, the corresponding parts are more strongly pushed against the paper, the consequence being darker outlines or shades. A deal of nicety is required in printing, and the effect of a Wood-Cut very greatly depends on the pressman employed. This remark applies of course, only to such as are printed by hand presses; but the great majority of cuts are at present worked by steam machines. These are not so well adapted to the purpose, and impressions very often suffer a good deal in their appearance, when the engraving itself is a good one. The greatest part of the work is done by the graver; the tint tool has a very thin blade and point; it is used in cutting parallel lines near one another, so as to produce an apparent depth of color, as in the sky. The gouge is used for paring away masses of wood for which there is no use. The block of wood is placed on a leather pad, stuffed with sand, and held firmly with the left hand, whilst the right is employed to move the tool. When the work has proceeded to an extent which makes the artist desirous of seeing its effect, he takes an impression on thin India paper, with his hand, and then he is able to judge of the merit of his labor, and he can see whether he has made any mistakes that will mar the general effect of the cut. Engravers assert that it is very difficult to correct a fault in the cutting, and they generally consider it the best policy to begin on a new block to alter the old one. Sometimes, when the fault is within a narrow compass, they ingeniously cut a piece right out of the wood, and insert another piece in its place.

Engraving on metal, is a much more complicated process, and there is much greater diversity in it than in wood engraving. Vasari tells us that the art of printing from engraved plates was the accidental discovery of Maso Finiguerra. He was a worker in niello, that is one of those goldsmiths of Italy, who traced designs, sometimes simple, sometimes complex, on plates of silver or other metal, and then filled up the lines with the sulphate of silver a black substance. The lines were thus made to contrast with the rest of the plate, and something of the effect of our engraving on paper, was produced. It is said that Finiguerra, desiring to see the effect of his work, before going through the final process that of filling in the black substance, applied a coloured fluid to the plate, and then took an im-

pression on paper. Whether this simple process was first used by this particular goldsmith or not, certain it is that the earliest intimation of an engraving from metal is an impression of a niello plate by him. It was taken from a pax, (the vessel in which the consecrated bread was placed,) which is still in existence at Florence, dated 1452, and in the Royal Library at Paris, may be seen the impression alluded to. There are thirty minute figures very beautifully designed, representing the Coronation of the Virgin. The steps by which the idea thus obtained was improved, do not appear, but not many years elapsed before we find persons whose occupation it was to engrave metal plates for the purpose of taking impressions on paper.

Before the artist applies his engraving tools to a plate of copper, it has to undergo a certain preparation. It is first hammered perfectly plain, and afterwards polished with pumice stone, then with a fine kind of slate, then with charcoal and finally with oil rubber. The plate is next evenly covered with a thin coat of wax prepared with asphaltum and pitch. The design intended to be engraved is drawn on paper the back of which is rubbed with red chalk dust. This being laid upon the varnish, the drawing is gone over with a fine point and thus the design is transferred. The paper being removed, the artist traces the outline through the wax upon the copper and this having been done, the wax may be taken off. The effect of line engraving is produced as the term imports, by a series of lines of different degrees of thickness and closeness but without dots or other marks. The chief study of the line engraver (says a writer on this subject) is to make such an arrangement of lines as shall mark the character of the various objects, whether they stand forward in bold relief or are mellowed by reflected or borrowed light, in short to convey to the eye the various gradations of colours which have been expressed by the artist on canvas and finally to preserve the whole in its proper keeping or such a disposition of the various lights and shades (termed chiaroscuro) as shall leave no doubt as to the intended place of any object on the plate; for although the lights and shadows of nature are continually varying in direction and intensity throughout the day, still all objects preserve their relative value in the landscape. In giving smoothness and polish to an object the lines are parallel, sharp and clear in their course. To throw an object into the shade, and to give it a dull appearance, lines crossing each other perpendicularly are used, and are termed square hatchings, but where an intermediate state is required, the lozenge hatchings or lines crossing each other at an angle less than a right angle are employed. Where a waving or a flowing effect is to be produced, the hatchings will be slightly curved, but where an object is brought prominently into relief, various intervals in the shadings will produce the desired effect. Engraving with the dry point, as it is called, is executed by a sharply pointed needle which must have been carefully ground in a groove, to preserve its conical shape. The burr which the instrument raises has to be skilfully taken away afterwards.—The dry point engraving is not often used without the help of other styles, but six pieces of Rembrandt are mentioned as being produced entirely by this method.

(To be concluded.)

Foolishness of Profane Swearing.

A gentleman being in company with a number of persons in a stage-coach, who used very profane language, was invited, after the rest had exhausted their fund of anecdote, to tell his story. He complied, and as they had interlarded every sentence with some senseless, profane expressions, he substituted the phrase, "tobacco and pipes! pipes and tobacco!" His companions listened with perfect astonishment—they concluded the man must be insane! But, after he was done, and they professed themselves much pleased with his story, one of them took the liberty of inquiring what he meant by the frequent use of the above phrase. Oh, said he, it is my peculiar method of swearing! Whereupon they saw at once the extreme silliness of profane language, and abstained from its use during the rest of the journey.

Importance of Flannel.

The following extract from Robertson on Diet and Regimen, should not be lightly overlooked by emigrants to California.

Sir George Ballingall, in his lectures on military surgery, adduces the testimony of Sir James Macrigror to the statement that, in the Peninsula, the best-clothed regiments were generally the most healthy; adding that, when in India, he witnessed a remarkable proof of the usefulness of flannel in checking the progress of the most aggravated form of dysentery, in the second battalion of the Royals. Capt. Murray told Dr. Combe that 'he was so strongly impressed from former experience, with a sense of the efficacy of the protection afforded by the constant use of flannel, next the skin, that, when, on his arrival in England, in December, 1823, after two years' service amid the icebergs on the coast of Labrador, and the ship was ordered to sail immediately for the West Indies, he ordered the purser to draw two flannel shirts and pairs of drawers for each man, and instituted a regular daily inspection to see that they were worn. The precautions were followed by the happiest results. He proceeded to his station with a crew of 150 men; visited almost every island in the West Indies, and many of the ports of the Gulf of Mexico; and notwithstanding the sudden transition from extreme climates, returned to England, without the loss of a single man, or having any sick on board on his arrival. It would be going too far to ascribe this excellent state of health solely to the use of flannel, but there can be little doubt that the latter was an important element in Capt. Murray's success.

California the ancient Ophir.

Major Noah in a long article propounds the novel doctrine, "that California is the ancient Ophir,"—that land where the great Solomon got so much gold "and silver?" to build the glorious old Temple at Jerusalem, and which fell a prey to the fierce Egyptian soon after Solomon's death. He infers, from the vast amount of the gold of Ophir used in the construction and ornaments of Solomon's temple, the length of the voyages of the ships which were sent for the gold, and various other considerations, that it was California gold that so wonderfully and magnificently enriched the famous temple of antiquity. The Major states the cost of the temple at upwards of four hundred and fifty millions of pounds sterling—a sum hardly to be compared with any single financial account on record, except the national debt of Great Britain.

The ships sent by Solomon and Hiram of Tyre for the gold and treasures of Ophir, required three years to make the voyage, and as the locality of Ophir has not been ascertained, and as the length of the voyage would seem to correspond very well with the distance to California, Major Noah therefore concludes that ancient Ophir and modern California are one and the same place.

The Lost Ten Tribes.

The Major also believes that the Indians are the descendants of the lost ten tribes that were carried away by Salmanezar and went into a far country. He believes that they crossed from Asia by Behring's Straits to our continent and finally peopled our whole country. The reasons of his belief are stronger evidence of our Indians being of Scythian than Hebrew origin—their rights, customs and language are radically Scythian. The true test of Jewish descent, above all others, is the "keeping of the Sabbath.

Madder.

The most of our madder used in the country is procured from Belgium. Kentucky, Missouri, Tennessee, Arkansas, and perhaps the whole southwestern country would produce it well. A madder plantation requires a good deal of preparation and some 3 or 4 years before a large and regular yield can be expected. Deep ploughing and bedding and thorough manuring, are requisite; but when once prepared, the expenditure of labor is not so heavy, and where properly arranged the crop is annual, that is to say, one third or one fourth of the land is digged each year, producing several hundred dollars per acre.

London is affected with the California gold fever.

Mr. King's Report on the Panama Railroad.

A correspondent of the Union, who appears to have examined thoroughly Mr. King's Report on the Panama Railroad, and the statement of the distances between New York and certain ports on the Pacific and the Indian Oceans, by the old routes around Cape Horn and the Cape of Good Hope, as compared with those by way of Panama, says the distances are reduced below the possibility of navigation on the Panama route, while those around the Cape of Good Hope are considerably exaggerated. He says:

The difference between the sailing distances to Canton on the two routes, is certainly far less than is represented in the Tables contained in the report. The route by way of Panama cannot be fairly reduced by 12,000 miles, nor can that around the Cape of Good Hope be reasonably estimated at more than 15,500. Calcutta may be considered as nearly equally distant from New York by these two routes. The extreme importance of the subject has induced me to offer these remarks to the public, in the hope that they may render more cautious those who are concerned in projects with regard to the Isthmus, as well as those to whom is committed the determination of the amount of assistance to be given by our government to such projects.

The Barometer.

Torricelli invented, and Pascal perfected this instrument, and it is of great use, not only in foretelling the changes of the weather and thus saving the lives of navigators, and preventing the loss of millions of property on the ocean, but also in enabling us readily to ascertain the height of mountains, or of any other situation to which it can be taken.

This instrument falsifies the ancient maxim that "nature abhors a vacuum." The barometer is constructed upon the principle of atmospheric pressure. The atmosphere on a clear day will support in a vacuum a column of mercury 30 inches in height. It is therefore ruled in this height in the tube by the pressure of the atmosphere, and this is the reason why the barometer is not affected in houses to indicate the nature of the weather. The barometer is employed to measure heights, as the mercury falls the higher we ascend. The rising mercury indicates the approach of fair weather, and the falling mercury indicates foul weather. No captain should go to sea without a good barometer, and the vertical kind are the best. There is no person but can easily make one for himself.

Advice to Children.

You were made to be kind, (says Horace Mann,) generous and magnanimous. If there is a boy in the school who has a club foot, don't let him know that you ever saw it. If there is a poor boy, with ragged clothes, don't talk about rags when he is in hearing. If there is a lame boy, assign him some part of the game which does not require running. If there is a hungry one, give a part of your dinner. If there is a dull one, help him to get his lesson. If there is a bright one, be not envious of him; for if one boy is proud of his talents, and another is envious of them, there are two great wrongs, and no more talents than before. If a larger or stronger boy has injured you, and is sorry for it, forgive him, and request the teacher not to punish him. All the school will show by their countenances how much better it is than to have a great fist.

A Bone Picker.

"I've got a new machine," said a pedler, "for picking bones out of fishes. Now I tell you it's a little the darndest thing you ever did see. All you have to do is to set it on a table and turn a crank, and the fish flies rite down your throat, and the bones rite in the grate. Well, a country 'greenhorn' got hold of it the other day, and he turned the crank the wrong way, and I tell you the way the bones flew down his throat was awful; why, it stuck the fellow so full of bones that he could not get the shirt off for a whole week!"

Since the appearance of cholera in the West the Roman Catholic Archbishop has notified the members of the church that abstinence from the use of meat on Fridays is abolished until further notice.

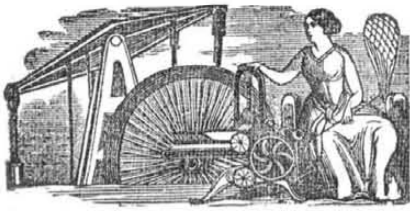

New Inventions.

Improvement in Paddle Wheels.

Mr. William Webster of this city has invented a new improvement in paddle wheels, which is certainly destined to perform wonders in navigation. He employs two or more paddles like vertical oar blades between the rim of the wheel instead of one solid rectangular paddle, and by a very simple and ingenious mechanical arrangement, the paddles are operated, so as their greatest amount of surface, will act upon the water while passing through it, and to present their edges to the face of the wheel when rising out of, passing through the air, and entering the water. They act most effectually where they are wanted to act, and offer little if any resistance to the medium through which they pass, where they cannot act to propel the vessel. Measures have been taken to secure a patent.

Invention to Prevent Collisions on Railroads.

Mr. W. Frœlich, engineer in the Navy Yard at Washington, has invented an apparatus which is radically self-acting to prevent railroad collisions. He has executed an operative model which demonstrates that even in the event of two trains meeting at full speed it will operate without the help of engineer or fireman and prevent a dangerous collision. As he has taken measures to secure a patent, he is now ready we are informed to enter upon negotiations with Railroad Companies on reasonable terms.

Enamelling Iron.

In a great number of cases, articles made of cast Iron require to be glazed. The substances employed for this purpose and the manner in which they are applied, are kept somewhat secret by the craft. We have had many enquiries made of us respecting this art, which we have answered freely, with the knowledge we have had of the subject. A short time ago however the following Improved process came into our possession, and we hasten to lay it before our readers. Knowing that it will be of no small value to many of them.

The articles of Cast Iron must be thoroughly cleaned first, and then they are ready to receive the first coat, which is made of the following substances. 100 parts of calcined flints, ground to a fine powder, and mixed with 75 parts of fine grained borax, this mixture is then fused together, and when cooled it is ground with 22 parts of potter's clay in water until it is of such consistency that when an article to be glazed is dipped in it a coating of about one sixth of an inch is retained on it, when the articles so dipped are set apart in a clean place to allow the composition to set, as it is technically termed. When the articles are yet moist, the following composition to produce the glaze, is carefully sifted over the surface. Take 100 parts of what is called cornish stone, or red limestone ground fine, 117 parts of borax ground fine, 35 parts of soda ash, 35 parts of saltpetre, 35 parts of sifted lime, 50 parts of white glass well pounded and 13 parts of white sand. These materials are well mixed and vitrified (burned in a crucible) and when cool they are ground to a fine powder which is washed and dried and laid past in a dry place for use. About 45 parts of these materials are mixed with one part of soda ash in hot water—being well stirred together and then allowed to dry in an oven of a stove, when a fine powder is produced. This is a powder that is sifted over the surface of the moist primary coating spoken of before. After the articles are dusted over with this, by a dust bag, they are placed in the oven of a stove and kept at a temperature of 212 degrees till the composition is dry, when the articles are then placed in a kiln or muffle and submitted to a sufficient degree of heat to fuse the glaze, should the glazing not be found

perfect all over, the articles may be moistened with a little salt and water, and the glazing powder sifted over them again and then subjected to the heat of a kiln or muffle again.

This is a good composition for coating the inside of iron pipes, which can be done by holding the pipes on an inclination with their lower ends in a tube, and pouring the first mixture down from the top, taking care to keep the pipes turning round so as to spread the mixture equally over all the interior surface. When this is slightly dry on the surface the glazing powder may be dusted freely

in at the top turning round the pipe—and letting the powder spread equally all over the surface down to the bottom, when the pipes may be put into a long kiln made for the purpose and the glazing powder fused. These materials make a splendid glaze and have been considered the best substance as combined for a good iron enamel.

The cornish stone may be left out of the composition without any detriment to its quality. For enamelling the outside of cast iron articles the above process will be found to be the best yet discovered.

IMPROVED BRICK PRESSING MACHINE.

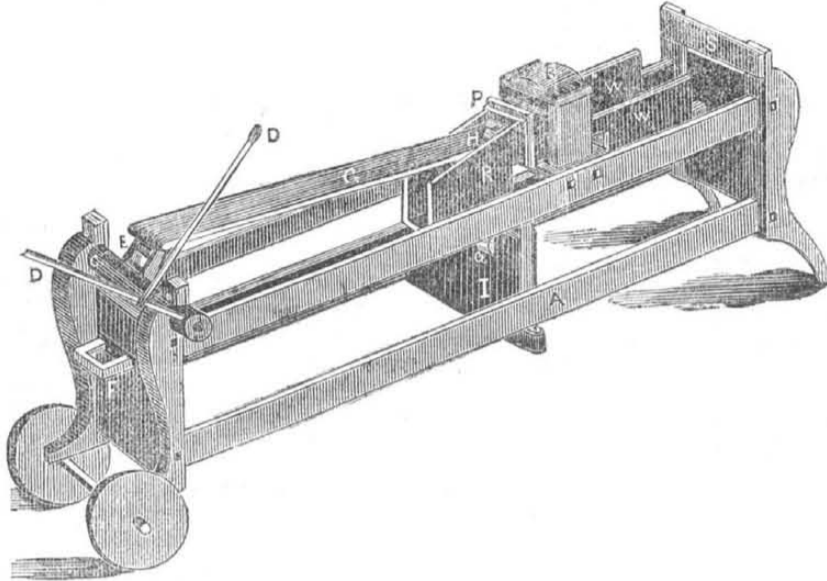

This is a machine for pressing brick to give it that smooth and beautiful form, required for the fronts of buildings. It is very simple and easily managed and does credit to the inventor, Mr. Nathaniel Adams of Canterbury, Orange Co. N. Y., who has distinguished himself already for more than one invention.

A, is the frame. There are wheels at the one end, and the two legs at the other end will answer for handles to wheel it from place to place, it being a very convenient and portable machine. B, is the box in which the brick is pressed. This box is formed of stationary sides and top, but the back is moveable, a solid square block secured to a sliding frame. This sliding frame runs from end to end of the machine supported on and working in slots on S, and also at F. It is also supported on the bearing plate I, attached to the frame near the middle, sliding on the top of two friction rollers a, (one only seen) R, is a shoulder on each side of the follower G.—These shoulders are bolted to the sliding frame below and are elevated to support the piston P, which is a square block, to be pushed by G, and press the brick into the box. H, is a tongue joint by which the follower is connected to the piston. W W, are two square arches, as they may be called. They are two side plates with slits in their underside and to these is secured on the inner side the back of the box B, of the same shape as the square piston P. These are connected to the sliding frame below, so that when the sliding frame is moved the follower G, the piston P, and R and W W, are moved at the same time. The follower G, is connected with C, the fulcrum, by a tongue with a spindle through it on the fulcrum which is embraced by two jaws on the underside of the follower as seen at E, which thus forms a very flexible joint of the toggle kind. There is an excavation on the roller to receive the butt end of the follower at that point where the tongue E, is moved so as to be on a line with the bottom of the follower. At that point no power is exercised by the tongue to move the follower in pressing the brick, but as the butt is caught into the recess on the fulcrum, the lever D is employed to act upon the whole length of the follower and thus exert the greatest lever power, when it is most wanted—to give the finishing touch to the brick. The brick is placed upon a projecting platform on the bottom of the box and the back of the box is the front of it when the pressing commences but recedes before the piston a certain distance, till backed by S, while the piston P, can move or travel farther with the compression of the brick. W W, therefore do not travel so far as N and

P. The slits mentioned guide the arches to move only a certain length, viz. the exact width of the box B. They therefore rest and slide on the bars below of the sliding frame. This is the way in which the pack of the box B, and the piston P, are guided and moved to press the brick and graduate the distance (not uniform) between the two for the compression of the brick. Measures have been taken to secure a patent.

Irvin's Percolated Propeller Churn.

This is an invention of Mr. G. A. Irvin, of Paris, Bourbon Co. Kentucky. The improvement is on the dashers of churns, and will at once be appreciated as being very simple and which is not the subject of any objection that has been urged against producing butter by mere atmospherical agitation.

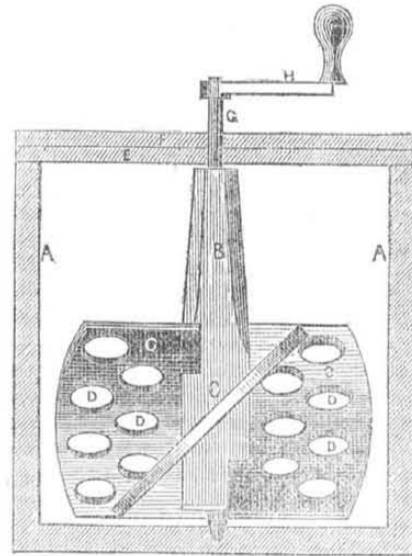

This is an elevated section. A, is the churn. B, a collar round the revolving vertical shaft G. E, the lid, and H, the handle. C, are the dashers; they are secured to B, around the vertical shaft, and are set nearly at an angle of 45 degrees to one another, as is seen by the edge of one herein exhibited. D, are holes or perforations in the dashers. They are shaped something like the flukes of a propeller. As the dashers are full of perforations, it will be observed from the way in which they are set, that the particles of the milk or cream, are most effectually submerged and thrown upon upon the surface alternately, carrying out the old principle of churning (which so many still like best) but in a different and far superior manner. Measures have been taken to secure a patent.

Mr. Daniel Woodbury of Rochester, N. Y. has made a beautiful improvement on his "Grain Separator."

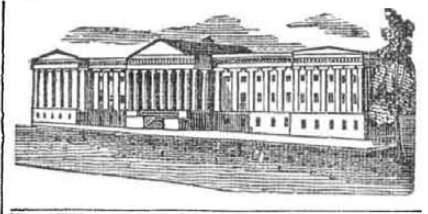

LIST OF PATENTS

ISSUED FROM THE UNITED STATES PATENT OFFICE,

For the week ending January 23, 1849.

To H. Felton, P. D. Cummings and H. Hinchly, of Portland, Me., for improvement in cast iron Car Wheels. Patented Jan. 23, 1849.

To J. F. B. Flagg, of Philadelphia, Penn., for improvement in Rails and Wheels for turning Curves of Rail Roads. Patented Jan. 23, 1849.

To S. R. Parkhurst, of West Bloomfield, N. J. for improvement in Cylinders for carrying and supporting Cards, &c. Patented Jan. 23, 1849.

To F. A. Calvert, of Lowell, Mass. for improvement in the manufacture of Cylinders for Burring Wool, &c. Patented Jan. 23, 1849.

To Elisha Luter, of County of Robertson, Tenn., for improvement in Shingle and Stave Dressing Machines. Patented Jan. 23, 1849.

To William Grant, of Boston, Mass. for improvement in Chucks for Lathes. Patented Jan. 23, 1849.

To James Cortlan, of Washington, D. C. for improvement in Shower Baths. Patented Jan. 23, 1849.

To P. P. Read, of Bowdoin, Me., for improved Roller Ox Shoe Machine with moveable Dies. Patented Jan. 23, 1849.

To E. J. Dickey, county of Chester, Penn. for improvement in Seed Planters. Patented Jan. 23, 1849.

To J. C. Miller, of Marietta, Penn. for improvement in Seed Planters. Patented Jan. 23, 1849.

To F. A. Calvert, of Lowell, Mass., for improvement in Wool Cleaning and Lapping Machine. Patented Jan. 23, 1849.

To A. B. Taft, of New York City, for combined Double Hinge and Spring. Patented Jan. 23, 1849.

To William Schnebly and Thomas Schnebly, of New York City, for improved self-inflating and folding Life Boat. Patented Jan. 23, 1849.

To M. Fisher and William Martin, jr. of Newport, Me. for improved process for welding Cast to Wrought Iron or Steel. Patented Jan. 23, 1849.

To J. K. Parke and C. S. Watson, of New York City, for improvement in Machines for making Envelopes. Patented Jan. 23, 1849.

To John A. Whipple, of Boston, Mass. for improvement in taking Daguerreotype Pictures. Patented Jan. 23, 1849.

To Alexander Wright, of Lowell, Mass. for improvement in Guards or Strippers for Burring Machines. Patented Jan. 23, 1849.

To H. Angus, of New Haven, Conn. for improvement in Carving Machines. Patented Jan. 23, 1849.

To A. S. Pelton, of Clinton, Conn. for improved combined Hinge Fastener and Shutter Opener. Patented Jan. 23, 1849.

To C. F. Tuttle, of Williamsburg, N. Y. for improvement in Registers for Hot Air Furnaces. Patented Jan. 23, 1849.

DESIGN.

To N. P. Feck, of Springfield, Mass., for Design for Stoves. Patented Jan. 23, 1849.

Counterfeit Detector Balance.

Mr. C. Rodgers, of Jefferson, Wisconsin, the inventor of the Electric Cholera Protector, has invented a new and beautiful registering balance for weighing coin and detecting the spurious kind. The beam which is used to weigh is fixed upon a fine steel point and the receiver for the coins is made to measure the true size and the beam is marked on one side in grains and on the other with numbers corresponding to a manual giving the weights of gold and silver coins. There is an indicator which points to the registered weight of the coin. This detector is constructed upon the well established fact, that no counterfeit alloy is the same in size and weight as the genuine, and with the most sensitive acumen this invention detects the counterfeit.



NEW YORK, FEBRUARY 3, 1849.

Balloons.

The idea of human beings navigating the air, is an old and a favorite one. We are informed that Abaris the Scythian, having received an arrow from Apollo during the Trojan war, transported himself through the air from Athens to Scythia. We are also informed that Dædalus constructed wings with feathers and wax and carefully fitting them to himself and son flew away from Crete, but Icarus having ventured *too high*, the sun melted the wax from his wings and down he came into the sea, which still bears his name. The same event could not happen now, for oh, great changes, the higher we now fly, the colder it becomes.

Roger Bacon was among the first persons in modern times, who took up the subject of aerial navigation, and Bishop Wilkins in his work on Mathematical Magic, considers flying a very easy art, but to man, the good Bishop says, "Providence has not permitted such a depraved creature this facility which he may employ to do mischief." In 1673, a celebrated character named Bernovin, a native of Grenoble and an excellent surgeon, had acquired the art of making artificial fire works by which means he could fly through the air on a sheet, and had in not a few instances descended from high towers in this manner. In the month of January in the above year he again attempted the feat from a high tower in Ratisbone, but he unfortunately lost his life in the attempt.

It was not until 1782 that any progress was made in Ballooning. In that year Cavendish discovered hydrogen gas, which was found to be 16 times lighter than the common air, but considering the impurities connected with the common mode to obtain it, namely by iron filings in dilute sulphuric acid, it cannot be considered to be more than six times lighter than the atmosphere, consequently a globe of hydrogen gas can only be impelled upwards by a power equal to five times that of the weight of an atmospheric globe of the same size, therefore the force with which balloons can ascend must be in proportion to the cube of their diameters—minus the weight of the envelope which for the finest gummed silk sufficient to cover a globe 1 foot in diameter, is about one-twentieth of a pound. It is therefore evident that according as the diameter of a hydrogen balloon is increased, so is its upward propelling power. One (a globe) 24 feet in diameter made with the fine silk, has an upward propelling force of only 456 pounds, while one of 60 feet diameter has an upward propelling force of no less than 6950 pounds.

In 1782, two brothers of the name of Montgolfier, in France, made the first ascension in a balloon of 23,000 cubic feet. Their experiments however, were but small affairs in comparison with the experiments made by Guy Lussac, the scientific Frenchman, who with Biot in 1794, found the needle remain unaltered at 12,650 feet elevation and at 18,000 feet the thermometer fell to the freezing point. He filled two flasks with air at 23,040 feet elevation—higher than the loftiest mountain on the earth, and having analyzed the air afterwards, he found that it contained the same constituents as that at the surface of the globe. Since that period many voyages have been made in balloons, and many have thought that balloons might be made of such a form as to navigate the air with wings. All such attempts have proved abortive. In 1784 two brothers named Roberts, Professors of Philosophy in Paris constructed a balloon of an oblong spheroid form and attached wings to the car to propel themselves. They ascended 14,000 feet and in a calm had recourse to their wings by which they described an elliptical segment of 6000 feet diameter.

All may remember the great feat of Mr. Green in 1836, who performed a journey from

London across the English Channel to the German province of Nassau in 18 hours. His balloon was so large that he carried a ton of ballast. Many of the aeronauts have distinguished themselves, and it is not forgotten how that Dr. Morrell came near losing his life in his balloon excursion from this city last year. To the shrewd man of science balloons have ceased to be a matter of interest—their object of late has been more to amuse the crowd and benefit the adventurer. A patent was taken out for a flying machine in England in 1847, and the British Association voted \$1250 for balloon experiments in 1840, all of which have ended in *nothing*. If any person wishes to distance space in travelling, we would advise him, instead of trying a balloon, to get well charged with a galvanic battery and mount the telegraph wires, if he loses his balance in the journey, we can assure him that there is no fear of falling farther than the centre of *gravity*.

Report of the Patent Office.

The Report of the Commissioner of Patents for 1848, will be the best document which has ever emanated from the office on account of the great amount of valuable scientific information which it contains. It presents a brief history of the Patent Office up to 1849. From 1790 to 1849 the number of patents issued are given as follows:—

States.	No. Patents.	States.	No. Patents.
Maine	: 463	Mississippi	: 23
New Hampshire	: 297	Louisiana	: 77
Vermont	: 310	Arkansas	: 0
Massachusetts	: 2161	Tennessee	: 108
Rhode Island	: 234	Kentucky	: 185
Connecticut	: 1156	Ohio	: 749
New York	: 3382	Michigan	: 51
New Jersey	: 461	Indiana	: 114
Pennsylvania	: 2167	Illinois	: 71
Delaware	: 52	Missouri	: 40
Maryland	: 660	Florida	: 1
Virginia	: 630	Texas	: 4
North Carolina	: 137	Iowa	: 2
South Carolina	: 122	Wisconsin	: 8
Georgia	: 80	District Columbia	: 224
Alabama	: 65		
Total		: 14,034	

The following table shows what cities have taken out the greatest number of patents in proportion to the rest of the Union—yet we must not judge by this that other cities have not as much mechanical ingenuity in proportion to their population. The four cities here mentioned were flourishing places when Cincinnati was the dwelling place of the wild deer and buffalo.

Boston	: 623	New York	: 1787
Philadelphia	: 960	Baltimore	: 430
Total		: 3800	

The proportion which the inventive genius of Boston bears to that of the State of Massachusetts, is about one-third of the whole.—The proportion of the city of New York to the State of New York is more than one-half of the whole. That of Philadelphia to the State of Pennsylvania as 3 to 7; and of Baltimore to Maryland as 2 to 3.

Pleasure Carriages.

Within a few years a great improvement has taken place in the construction of our pleasure carriages. There can be no doubt but America has long excelled in constructing light and airy looking carriages. The fault to them was that they looked *too airy*—not rich and solid. These objections are now entirely removed by our coach-makers who combine all the requisite qualities in their carriages of a *janty* light, strong and yet rich and solid appearance at the same time. There is a kind which has been recently introduced which is highly to be commended. They are a combination of the close and open carriage, suitable for sun-shine and storm, resting upon elliptic springs in front with no perch. The pole works on a knuckle in front of the draw bar, which thus takes the strain off the carriage when in motion and the coachman's seat is separate from the main body so that he is always in line with the horses, thereby enabling the carriage to turn in a far narrower curve than by the old arrangement.

The Artesian Well at Charleston, S. C. has now reached a depth of 428 feet and the water is one foot from the surface.

American Manufactures.

MR. EDITOR.—Since the publication of your article in the Scientific American of the 30th ult. headed "Advice to Manufacturers," I have examined each successive issue of your paper, with considerable interest, hoping to find some *satisfactory* reply to the observations you then made, especially to your query "why we are not able to compete with foreign manufacturers in coarse goods now when it has been so often stated that we could undersell them in their own markets." As nothing to the point has yet appeared in your columns, I submit the following, which if it does not throw some light upon the subject, may pave the way for more correct information from others.

The British cotton manufacturers—whose intelligence, enterprise and comprehensive views in all matters relating to the advancement of their art, had previous to 1831 maintained the monopoly of nearly all neutral foreign markets for the sale of cotton piece goods made of yarn numbering from 10's to 24's. At this time (1834), we first hear of them complaining seriously of American competition.

In 1834 the importations of American piece goods at the Canton market exceeded the amount imported from Britain by 91,000 pieces, and the imports of the Americans were double in 1834 compared with 1833. at Bengal. Indeed many of the oldest and most experienced manufacturers of Glasgow, and other places, at that time abandoned markets they had been in the habit of supplying for years, in consequence of American competition.

Let us look at the condition of the manufactures of both countries at that period, and we shall find the position of the Americans was much more favorable than the British for enabling them to manufacture these goods at a cheap rate.

Lowell had just then sprung into existence as if by magic, and the great advantage of concentrated capital, together with that vigor that accompanies all new enterprises enabled her manufacturers to throw a flood of goods into foreign, as well as domestic markets, at a much cheaper rate than had been known hitherto. The machinery in her mills was as perfect as at the present day, and possessed every advantage for producing large quantities, that had yet been known in Europe. The hours of labor in the mills were nine per week more than the British were allowed to work by law.

The British manufacturer had then to pay for freight on cotton from Mobile and New Orleans 1½ cents per lb. according to Dr. Ure, also an import tax of five sixteenths of a penny, which after making a proper allowance for waste would be equal to about 3-4 of a cent per lb. on clothes. The odious corn laws too, by keeping up the price of provisions, sustained wages at a high rate. The starch consumed in the manufacture of coarse goods is an important item of their cost, and this being generally made of flour, its cost would be ruled by the market price of that article. What is the condition of the parties now. The American works with machinery nearly upon the same principles established in 1834, and the price of provisions has increased if any thing. While the British manufacturers have improved their machinery, and mode of manufacturing so as materially to increase their quantity, ½ cent is now paid for freight instead 1½. The import tax on cotton was abolished, I think in February 1845, and the corn laws which have been modified at different times in favor of the consumers, are to be entirely abolished in February of the current year. Thus we see that *free trade* operates in favor of the British manufacturer and against the American, and in our humble opinion the present free trade system will keep the latter behind the former, with fair competition in both home and foreign markets, for many years to come.

Yours respectfully WM. MONTGOMERY.
Craigville Jan. 24th 1849.
[We request especial attention to Mr. Montgomery's views. No man in America—from his position and connection—is able to throw more light upon such subjects.
We have a very good article from a New Hampshire correspondent upon "the influence of Factory Life," which will appear next week.—Ed.]

Reform in the Patent Laws.

Having no wish to enter the arena of literary strife for your liberal offer in respect to an essay on the Patent Laws, I would respectfully through the columns of the Scientific American suggest the following reforms in the management of the Patent Office:

1st. The entire Agricultural Department made separate from the Patent Department. The Patent Office Reports have occupied more space for agricultural statistics than inventions, and as a surplus fund exists in the Treasury of the Patent Office, it is right that inventors and patentees should claim more devotedness to information which interests them as they are the individuals, and they only, for whom the Patent Office was established. I do not find fault with the Agricultural reports, they are good—let them be continued—but separate the duties and give us more scientific mechanical and chemical information respecting inventions.

2d. I would suggest the propriety of the Patent Office advertising in some proper paper three months prior to granting a patent, "that a patent is to be granted for such and such an invention,"—and let cause be shown why it should not be granted. And after this when a patent is granted, let it be impregnable to the assaults of those who would endeavor to rob the inventor of his just rights. At the present moment, a patentee is so liable to be annoyed by petty infringements that a patent in many cases does him more harm than good. There is a great reform wanted to protect a poor inventor from infringement, and I rejoice that there is one paper in our land, the Scientific American, that so ably advocates our rights—and as fearlessly as ably.

3. That inventors pay in \$60 as a patent fee, and the term be extended to 20 years, but in no case beyond that. Also, that if an application is not deemed patentable, that \$50 be returned, and the model also.

There are some other reforms that I would desire to see carried out, but

I remain at present, yours, W. R. N.
No. 14 Clarkson st. N. Y.

Explosion of a Boiler.

At Mobile on the 15th inst., a boiler in Spear & Co's Foundry, exploded with great force. The boiler was nearly, if not quite 15 to 18 feet long. It stood near the Foundry wall, which is four brick thick, with Press wall of nearly the same thickness on the other side, making a joint thickness of five to seven feet. In bursting, the whole boiler passed through both walls, and removed from the way of its passage, a tier of cotton, which, we were told, was seven or eight bales high and thirteen bales in length; passed across the press-yard, some thirty-five feet or more, struck down a heavy timber post, in the opposite shed, and before it spent its force, rebounded into the yard, after displacing and throwing down some four or five tiers of cotton.

A National Convention of Inventors is called at Baltimore. We shall notice this call next week.

Back Volumes of the Scientific American.

A few more copies of complete sets of vol. 3 of the Scientific American may be had at the office, either bound or in sheets. Price neatly bound \$27.5, in sheets suitable for mailing \$2. The second volume minus 4 numbers from being complete we can furnish for \$2 bound, or in sheets and mailed at \$1.50. Send in your orders early if you desire them filled for we have but a few more copies left of either volume, and the number is growing less every day.

THE SCIENTIFIC AMERICAN.

Persons wishing to subscribe for this paper have only to enclose the amount in a letter directed (post paid) to

MUNN & COMPANY,
Publishers of the Scientific American, New York City.

TERMS.—\$2 a year; ONE DOLLAR IN ADVANCE—the remainder in 6 months

Postmasters are respectfully requested to receive subscriptions for this Paper, to whom a discount of 25 per cent will be allowed.

Any person sending us 4 subscribers for 6 months, shall receive a copy of the paper for the same length of time.

For the Scientific American.
Light and the Human Eye.

There are various theories regarding the precise character of light. By some it is described "as very minute particles thrown off in all directions with immense velocity from luminous bodies." Others consider it as the effect of an undulation produced by luminous bodies in the elastic medium of the atmosphere, and producing an effect upon our organs of sight like sound on the air by vibrations of the atmosphere.

The former theory of material particles is called the theory of emission, the latter the undulatory theory.

Our opinion is in favor of the two theories combined, namely, that light is thrown off luminous bodies in all directions with great velocity and by a vibration. Whatever may be the absolute nature of light, we cannot tell, for we cannot handle it to dissect its anatomical structure. It is too subtle for the crucible of the chemist and the philosopher only knows that it is a remarkable property of luminous bodies that it enables us to perceive luminous objects themselves as well as other objects and that its absence produces darkness. All visible bodies may be divided into two classes, the self luminous, and the non-luminous. The former class possess in themselves the property of exciting the sensation of light; among these may be mentioned the sun in the heavens and phosphorescent bodies on the earth. The non-luminous bodies, although they may not emit light, yet they may possess the remarkable property of reflecting it and communicate the original emitted ray to a third, and so on. In ancient times it was believed that light was propagated from the sun and other luminous bodies instantaneously, but it has been discovered that although its velocity is great, yet it takes time to travel. It travels at the rate of 200,000 miles in one second. It proceeds in a direct line from the luminous body which produces it, and owing to this fact, all shadows are observed behind opaque objects and this is what makes the night season, for during that period we are in the shadow of our own world and this shadow reaches so far into space, that when the moon plunges into it in her course she undergoes what is called an eclipse. An eclipse of the moon is simply the shadow of the earth thrown so far into space as to darken for a brief period to us the face of the satellite.

As light advances from a candle or gas light it diminishes in intensity, and this diminution increases to the square of the distance at the rate of $4X^2=16$. In other words, if it would take the condensed light of four candles to reach one mile it would take the condensed light of 16 candles to reach 2 miles, but we must remember that as we lose the intensity of the ray, it fills a wider space.—Any parcel of rays passing from a point, is called a pencil of rays. An optical medium is a transparent body like glass. When rays of light are passing from one body to another of different density, they are bent from their former course and are said to be refracted. A ray of light which strikes the surface of a body and is thrown back again from the said surface, is said to be reflected. A looking glass is a reflector, and here let us mention a common error respecting the looking glass. When we look on a mirror, we behold a facsimile of ourselves. Now it is a popular error to suppose that our image has been in or that we see it on the mirror. The image never existed on the mirror and could not. The mirror simply throws back the reflected rays of light from our body upon the retina of the eye and the image is conveyed from thence by the optic nerve to the brain, or seat of sensation. Another popular error is, to suppose that the mirror turns about our image and shows us a left hand for a right one. In appearance this is the case, but this is an optical illusion. The hand which appears in contradistinction to our good right hand, to be our left in the looking glass, is still our right hand. When we move our right hand, the hand opposite to it in the glass (apparently the left hand) moves likewise. I have explained this optical illusion, because I once remember to have seen a philosopher nailed to the dilemma of not being able to tell the reason,

"why a looking glass turned round about the image of a person looking therein." He had not previously thought of this, or he would have said that "the image was not turned at all, or else the right hand in the looking glass would optically have appeared as the right hand of the person looking therein." It is upon a knowledge of the refraction and reflection of light, that all those instruments are constructed, which may be said to have brought heaven down to earth. The human eye is an optical instrument of rare and wonderful powers, and a brief description of it will not be uninteresting.

The eye is composed of three membranes and three chambers filled with humors. The outer membrane is named the *schlerotic*. It is thick, firm and white, except its anterior portion called the *cornea*, which is set in the opaque portion like a watch glass in its rim. The outer coat is lined with a thin dark membrane named the *choroid*, which is brown in some people and blue in others. That part which is seen and gives color to the eye is called the *iris*, and it has an opening in the centre called the pupil, which readily contracts or dilates according as more or less light is desired. In this respect the natural telescope surpasses all those formed by art.—The pupil of the eye is round in man and elongated sidewise in a sheep, while vertically it is an oval in a cat. The inner and third membrane of the eye is called the retina and this is formed by the optic nerve which enters the back part of the eye through the schlerotic and choroid coats and expands upon the interior into a whitish and most delicate membrane. It is upon the retina that the images of objects are received and produce impressions which are conveyed to the brain by the optic nerve. How this is done no man can tell—it is an action which proclaims man to be fearfully and wonderfully made. The fluids which occupy the cavities of the eye are of different densities. The cavity in front of the pupil and behind the choroid, is a clear watery liquid named the *aqueous humor*, and the chamber inside is filled with the *vitreous humor*. Behind the pupil there is what is called the *crystalline lens* a spheroidal body, firm, transparent and composed of a number of layers. This apparatus of the eye is to receive the rays of light which diverge from different points and to bring them to a point again upon the retina. There is one thing curious about the eye, namely, that the image formed upon the eye is inverted, which can be proved by the transparent eye of a white rabbit soon after it is dead, which if we place in a tube with the cornea outwards and look through the other end, we will see objects pictured upon its retina but in a reversed position. Some philosophers have contended that we perceive objects in this manner, but there can be no doubt about the optic nerve conveying the right position as well as the form of objects to the mind.

In man the eye performs a more exalted office than that of mere vision—it is the window of his soul. From the inmost recesses of the heart, we may behold looking out there, "fear, hope, disdain, revenge and love in every shape." What inspiration is displayed in its construction—what a wisdom and divinity in the offices it performs. R. M.

The Coast Survey.

From the Report of Prof. Bache, Superintendent of the Coast Survey, we gather the subjoined results of the last four years labors. The work has been carried into every State on the Atlantic and the Gulf of Mexico, with one exception, and surveying parties are now on their way to the Pacific Coast.

The differences of longitude of New York and Cambridge, New York and Philadelphia, and Philadelphia and Washington, have been ascertained by telegraph. The primary reconnaissance and triangulation have been carried from the southwest part of Rhode Island in to Maine. A base line of verification, of eleven miles in length, has been measured. The topography has been carried from Point Judith to Cape Cod, and has included the shores of Boston harbor and its approaches.

The map of New York bay and harbor and its environs, in six sheets, and the smaller

map in one sheet, have been published. Five charts of harbors of refuge &c. in Long Island Sound, have been published. One large sheet of the chart of Long Island Sound has been published, and another is well advanced towards completion. The complete chart of Delaware bay and river, in three sheets, has been published. The off-shore chart, from Cape May to Point Judith, is nearly completed. One sheet of the south side of Long Island delayed for work of verification, is nearly completed.

The primary triangulation has been extended across from the Delaware to the Chesapeake, and down the bay to the Virginia line. The triangulation of all the rivers emptying into the Chesapeake, north of the Patuxent, and part of the Patuxent has been made. The triangulation has extended over Albemarle, Croatan and Roanoke Sounds. The triangulation of the rivers emptying into the north and south sides of Albemarle Sound has been made, and the topography of the shores (with one exception) and of the Sound, has been completed.

A general reconnaissance has been made of the coast of South Carolina and Georgia. Also a part of the coast of Florida. A complete reconnaissance has been made of the coast of Alabama, Mississippi, and part of Louisiana. The topography of the shores of Mississippi Sound, as far West as Pascagoula, is complete, and of Dauphin Petit Bois, Round, Ship and Cat Islands. The hydrography of the entrance to Mobile Bay, and Cat and Ship Island Harbors, and their approaches, and of part of Mississippi Sound is complete. The computations and reductions have been kept up, and charts of the entrance to Mobile Bay and of Cat and Ship Island Harbors are in preparation.

During this period, an area of 17,554 square miles has been triangulated; the topographic surveys with the plane table have covered 2,318 square miles, and embraced an extent of shore line, roads, &c. of 7,179 miles. The hydrography has covered an area of 20,086 sq. miles, of which 16,824 were principally off-shore, or deep sea work. Four thousand four hundred and four copies of maps and charts have been distributed to literary and scientific institutions in our country, and to departments of our own and Foreign Governments. In the estimates for the next fiscal year, the total sum asked is \$158,000.

Curious Reminiscence of California.

Capt. George Shelvocke, in his account of the adventures of the "Speedwell," a ship of a 24 guns and 106 men, fitted out by certain merchants in London, for a cruise in the South seas, that sailed from Plymouth, February 13, 1779, in company with the "Success," under the command of Captain John Clipperton, says he visited the peninsula of California, which he thus described:

The eastern coast of that part of California, which I had a sight of, appears to be mountainous, barren, and sandy, and very like some parts of Peru; but, nevertheless the soil about Puerto Seguro, and (very likely) in most of the valleys, is a rich black mould; which, as you turn it fresh up to the sun, appears as if intermingled with gold dust; some of which we endeavoured to wash and purify from the dirt; but though we were a little prejudiced against the thought, that this metal should be so promiscuously and universally mingled with common earth, yet we endeavoured to cleanse and wash the earth from some of it; and the more we did, the more it appeared like gold. In order to be further satisfied, I brought away some of it, which we lost in our confusion at China. But, be that as it will, it is very probable that this country abounds in metals of all sorts, though the inhabitants had no utensils or ornaments of any metals whatever; which is no wonder, since they are so perfectly ignorant in all arts.

Public Libraries.

The United States contains 182 public libraries. The aggregate number of volumes in these libraries is 1,294,000. In the number of public libraries, France is the only country in the world which excels us. She has 841.

In the aggregate number of volumes Germany has five and a half millions, France five, Great Britain two and a half, and Russia one and a quarter millions of volumes.

The Way to Melt the Ice on the Side Walk.

Last week a gentleman in the upper part of our goodly city having been informed that salt thrown upon the ice on the sidewalks would rapidly melt it, resolved to rid himself of the annoyance in front of his own dwelling. On reaching home in the evening, after dark, he entered his store room, took a peck measure, and filled it with what he supposed to be fine granular fragments of genuine salt, and without saying anything to the dwellers in the house, slipped out through the area and scattered it freely on the walk, over an extent of ice of some two hundred feet. He retired to rest in excellent humor with himself, calculating upon the agreeable surprise awaiting the family and domestics when they discovered that the ice was entirely gone from the walk and steps. Judge then of his surprise on being told by one of the domestics, almost as soon as he got down stairs in the morning, that "some mischievous persons had been sprinkling rice all over the door steps and the sidewalk," coupled with the domestic's sagacious remark, that "she only wished the policeman had caught the rascal." The gentleman made no reply, but he came down to business rather earlier than usual that morning, and his family remarked that he must have something on his mind.

A Terrible Case of Suffering.

Mr. Richard Mosher, of Dutchess County, N. Y. has been confined to his bed for twenty five years, a victim to disease and intense suffering. During the first year of his attack his knees were dislocated and ossified, and subsequently other joints in his lower limbs were drawn asunder and ossified. Two years after these disastrous afflictions his pain became less acute, and being naturally industrious and ingenious he commenced making shoes, whips, and such other articles as he could, while lying in bed. He thus helped to maintain himself, and for eleven years he continued to work until his arms were dislocated and became ossified. For the last eleven years he has been unable to help himself in the least. His jaws were set some years since, and his teeth have been broken out, that food might be placed in his mouth. The only joints which he is now able to move are the extremities of his index fingers and one or two joints of his toes.

Habit.

Parents should endeavour to form good habits in their children—it makes all difficulties easy. Make sobriety, says Lord Brougham a habit, and intemperance will be hateful and hard; make prudence a habit, and reckless profligacy will be as contrary to the nature of the child grown or an adult, as the most atrocious crimes are to any of your lordships. Give a child the habit of sacredly regarding the truth, of carefully respecting the property of others, of scrupulously abstaining from all acts of imprudence which can involve him in distress, and he will just as likely think of rushing into an element in which he cannot breathe, as of lying, or cheating or selling.

To found these habits in children, however, is no easy task. But there are many men of splendid minds, those lives exhibit great struggles to break up and overcome bad habits formed in youth either by parental neglect or indulgence.

Funds for the Pope.

It is not improbable that Roman Catholics throughout the world will be called upon to contribute money to relieve the Pope from his present difficulties, and place him in an independent position. Something of this kind is hinted at by Bishop Hughes, of this city, who says: "Sooner than we should see him (the Pope) subject to any Sovereign, or President or petty Prince, or King, we should have recourse to the old institution, and Peter-pence from every point of the compass would constitute a treasury to raise him above that subjection, even though he should occupy an island in the Mediterranean Sea a single square mile in extent."

At the late meeting of the Paris Institute, M. Bernard and M. Bareswell presented a sample of alcohol which those physiologists had obtained from the fermentation of sugar extracted from the human liver.

TO CORRESPONDENTS.

"J. R. of S. C."—In respect to the draft in chimneys—the American Scientific Association published a pamphlet last year, which we noticed, in respect to the best form of caps, &c., the result of many experiments.—That pamphlet we do not think can be got without writing to Cambridge College, Mass. There is also an excellent work, "Reid on Ventilation,"—it is scarce. The other questions cannot be answered in a more satisfactory manner than by the well known law of gain in expansion—to be found in every elementary work. For stationary engines there is no profit in using high pressure steam—and there is a limit to expansive working, viz. to have a regular speed of the piston during the full stroke. We shall give some opinions on the subject at another time. We have no machine for the barrel heads; a spring reciprocating small saw is as good as any.

"A. J. of Me."—See page 292 vol. 2 Scientific American, also page 284 same vol.—The first is Ayer's boiler feeder, and the second Treadwell's. From your description Mr. Ayer's appears to be the same thing. Be pleased to examine.

"W. F. of Washington."—None of the pamphlets can be purchased—they were only distributed to a few friends. You will see the accounts in the Franklin Journal of January, and in the next number in February. We think the Maltese cross cut off could be secured—we know of nothing to prevent it. This is what pleases us the most—it is a beautiful thing.

"J. H. C. of Conn."—Yours just came to hand when going to press. We will give it consideration. We are glad to receive such a practical and scientific communication.

"L. H. of Miss."—Yours has just come to hand.

"J. S. of Ohio."—Mr. Parker's wheel was patented in 1828, and the patent renewed, whether it has but one year to run or eight more we cannot tell at present, but we believe it has eight more to run—being extended 14 years.

"C. B. G. of Ct."—Yes; we have got a full description of Mr Taggart's flying machine and drawings of it, but we do not discover that it possesses any more novelty than some that we have seen illustrated in old foreign works which have been long since abandoned. It is possible that you have got something superior to any thing with which we are acquainted but we should advise you to inform yourself upon the past and rejected modes which have been tried for accomplishing the object before you spend much money in experimenting. First get the correct theory of aerial navigation and after that try your experiments. \$3 received, all right.

"A. J. of Ionia."—In answer to your enquiries we refer you to W. H. Seymour, Stockton N. Y., the inventor, of whom all the particulars can be obtained.

"C. H. E. of Utica."—Your funds were duly received. We have credited you one year's subscription to the Scientific American, and also caused the cut of your improved chair to be published in the Dentist's Journal, and hope to hear of your success.

"W. & G. of Detroit."—\$30 received—which is all right. Your business is progressing, and will be ready for your signature in a short time.

"H. & S. of Pa."—Your model has been received from Washington, and we think that it represents a good invention. Your certificate of deposit for \$300 has come to hand and is correct in amount as per our contract. The engine is nearly fitted for shipping and will be forwarded in a few days. We will write to you by mail and enclose a bill of lading as soon as the machinery is shipped.

"J. A. & Sons of Mass."—The engraving of your machine shall appear in 2 or 3 weeks. Your terms of payment are satisfactory.

"C. M. C. of Pa."—We are progressing with your drawings and specification and shall forward them for signatures in a few days.—\$30 received.

"N. E. C. of Conn."—The combination of centrifugal force and atmospheric air, could not be claimed. Although this is new as a principle to you, and your invention, yet it is

not new in the scientific world. We could show you this principle described before.

"Audrand of N. Y."—It is out of our power to give you so much of our time as to show you step by step the fallacy of your ideas, in making a perpetual motion by compressed air. We would advise you to employ your talents, which are not few, in the rationale of mechanical philosophy. You will soon be convinced that your project is based upon very wrong conclusions. The compressed air employed by the steam engine, was not a measure of power but convenience—and was a loss of power. It was to drive piles on Potts' plan in the middle of a river—the engine on shore

"H. M. of N. H."—Your plan for gold washing could not be carried out in California. The most simple plan is the water which allows the heaviest particles to fall to the bottom better than lead, as a great deal of the California gold is *feathery* in fine scales, and gold and other metals can amalgamate in a molten state.

"C. & G. of O."—The balance of your funds have been received and we have settled your account.

"J. S. G. of N. Y."—The engine of sixteen horse power advertised sometime since has been sold.

"A. C. B. of N. C."—The saw to which you refer was not the kind represented in No. 36 vol. 2, and it has been sold. Your order from Philadelphia has been presented and paid. The enquiries made in your former letter were replied to by mail.

"A. H. D. of N. Y."—No sir. There is not the least chance for you to get a patent if you should apply.

"I. V. K. of N. Y."—The model of your improved car wheel, was shipped in due time, to the Patent Office. The letter from the commissioner was written in the usual form, and had no reference to remissness on our part, we always send the models in proper time for examination.

"E. G. F. of Halifax, N. S."—Your draft was received on Monday and promptly honored by Messrs. S. & T. of this city. The communication to which you referred in a former letter has not been received.

"R. S. of N. Y."—Your model is received and we shall proceed with your business very soon.

"Z. R. of Vt."—We think you have hit upon a good plan and should be pleased to hear how you succeed with your experiments. If they prove as valuable as you represent, you had better forward a model to this office for examination.

Advertisements.

This paper circulates in every State in the Union, and is seen principally by mechanics and manufacturers. Hence it may be considered the best medium of advertising, for those who import or manufacture machinery, mechanics tools, or such wares and materials as are generally used by those classes. The few advertisements in this paper are regarded with much more attention than those in closely printed dailies.

TERMS:—CASH IN ADVANCE.

VALUABLE BOOKS.

We have now on hand, the following valuable scientific works, which can be sent to any part of the United States.

The Mechanical Principia, by C. E. Leonard, containing all the various calculations on water and steam power, and on the different kinds of machinery used in manufacturing, with tables showing the cost of Manufacturing different styles of goods &c. Price \$1 50.

Illustrated bound vols. of Thos. Ewbank's Hydraulics and Mechanics Price \$2 50.
Elementary Principles of Carpentry by Thos. Tredgold with 22 Engravings. Price \$3 50.
Scribner's Mechanics Companion, gilt edge, \$1 50.
Do Engineering, gilt edge, \$2 00.
Orders addressed, post paid, to MUNN & CO. Scientific American Office, New York.

To Locomotive Builders or R. R. Co.'s. THE undersigned would like to dispose of one half of his interest in a new invention called the "Radical Self-acting Collision Preventative Apparatus." It is an invention of rare merit as the inventor is ready to prove by various demonstrations. One of which is by a model. It is such a perfect anti-collision apparatus that no injury to passengers or cars need be feared even if two trains should meet while running at their usual speed. The inventor would like to associate with a partner for the purpose of immediately constructing the apparatus.
Address W. FROELICH, Engineer, Navy Yard Washington, D. C. \$3 31*

STEAM BOILERS.

BENTLEY'S Patent Tubular and other Boilers of any size, shape or power, made to order, by SAMUEL C. HILLS & CO. 43 Fulton st. n8

A SPLENDID WORK.

We have just published a work on the American Condensing Steam Engine which we take pride in saying has been pronounced by good judges to be the richest work on the Steam Engine ever published in America.

The diagrams of the Engine are represented on a large sheet of 38 by 28 inches, in size and present to the eye two distinct views, with their parts in elevation and in section, all strictly accurate, of a Condensing Engine as applied to our River and Sound boats. All the internal parts are also represented and a full description given in a book which accompanies the drawings. The diagram was designed and drawn by Mr. Frederick Cook, a well known draughtsman of this city.

Published and for sale at this office by, MUNN & CO Price complete \$3. They may be sent by express to any part of the United States. j27 tf

TO IRON FOUNDERS.

FINE Foundry Sea Coal dust, an improved article regularly used in the New York Foundries to mix with sand to make the sand come off the Castings easily; also fine bolted Charcoal, and Anthracite Foundry Blacking, Soapstone Dust, and Black Lead Dust, for sale in Barrels by

GEORGE O. ROBERTSON 283 West 17th st. New York.

Prices &c. forwarded to Founders in reply to post paid letters. 13 4teow*

SUPERIOR TURNING LATHES.

JAMES STEWART, 15 Canal-st. and 105 Elm-st. is constantly manufacturing and has now on hand between 50 and 60 superior lathes of the following descriptions and at reasonable prices, namely: Dentist's Lathes, very highly finished.

Common, Brass and Wood Turner's Lathes. Jeweller's and Pencil-case maker's very superior. J. STEWART is also authorized to act as agent for the sale of the celebrated Lathes manufactured by James T. Perkins of Hudson, of large size and at prices from \$250 to \$800. A specimen of this description may be seen at his factory as above. j27 tf

ADAMS' IMPROVED GUAGE COCK.

We have made such arrangements with the inventor and manufacturer of the above article that we are now able to furnish at our office any quantity of the celebrated Guage Cocks known as "Adams' Patent" on reasonable terms. The invention was represented by an engraving in No. 11 of this Vol of the Scientific American and is an excellent improvement. Price single \$10 with the right to use, and they may be sent to any part of the United States. Address MUNN & CO., Post Paid. j27

A Premium and Diploma were awarded by the New York Rensselaer Co. Fair, to S. Lichtenthaler, for his patent Blind fixtures, being an apparatus for Opening and Shutting outside Window Blinds, from the inside of the house, without raising the sash.

Persons desirous of obtaining patent rights of this invention for any of the Southern or Western States, will apply to the undersigned Patentee (the rights for the states of Maine, New Hampshire, Vermont, Massachusetts, Rhode Island, Connecticut, New York, Michigan, Ohio, Pennsylvania, Delaware, Maryland, the 11 northern counties of New Jersey, and the District of Columbia, are all sold off) S. LICHTENTHAELER, Litz, Lancaster, Co., Pa.

NOTICE.—All power of attorney given to C. H. Farnham, has been cancelled, and is hereafter null, and void, and he is therefore no longer authorized to sell, or transact any business appertaining to the above invention for me S. LICHTENTHAELER. j27 2m*

Patent Agency.

From our long acquaintance and experience in Patent Office business we have no hesitancy in asserting that we are better able to judge the merits of new inventions, and are better capable of advising upon all subjects pertaining to Patents than any other concern in the United States.

Any business connected with the Patent office may be done by letter through the Scientific American office with the same facility and certainty as though the inventor applied in person. During the past 3 years we have been constantly applying for Patents and what is a remarkable fact but 2 cases have been refused at the Patent Office and those 2 were afterwards granted by reapplication. Our prices too (another important consideration to inventors) are but about half as much as the charges of most agents as the amount of business which we do, and that in connection with the publication of the Scientific American renders to us superior advantage over all other agents.

Having been often complimented by those who have entrusted their business in our care, we here repeat what very many have said. "The best Patent Agency in the United States is at the Scientific American office."

All models, drawings or communications that are sent to the Scientific American office for inspection are deposited from the eyes of the public until the necessary application for securing the invention has been made.

The best of artists are constantly employed to make drawings from models and our corps of specification writers are composed of gentlemen formerly connected with the Patent office at Washington as Examiners.

All communications should be addressed to MUNN & CO. Scientific American Office. Post Paid. (d16) New York

DICK'S ANTI-FRICTION PRESS.

THIS Press, which was patented in October last, combines great simplicity of construction with intense severity of operation, compactness, convenience for use and cheapness, and is admirably adapted to a great variety of purposes, such as pressing Oils, Cotton, Tobacco, Hemp, Hay, Cheese, Cloth, Paper &c.; Baling goods; Embossing and Printing; Envelope Cutting; Jeweller's work; Shearing Metals; Hoisting vessels into docks; Gumming Saws; Making Lead-pipe; Punching, Rivetting and Cutting Iron &c. &c. &c. Orders and Communications to be addressed to WM. D. HARRIS, j6 3m* Agent for the Patentee, 138 Front st. N. Y.

SUPERIOR ENGINE LATHES.

We are manufacturing and selling at our establishment in New London, Ct. a superior article of Screw Engine lathes and also hand lathes of every dimension at an extremely low price. Address ALBERTSON, DOUGLASS & CO. Post Paid. [26 6m* New London, Ct.

GENERAL PATENT AGENCY.

REMOVED.

THE SUBSCRIBER has removed his Patent Agency from 189 Water to 43 Fulton street. The object of this Agency is to enable inventors to realize something for their inventions, either by the sale of Patent Goods or Patent Rights. Charges moderate, and no charge will be made until the inventor realizes something from his invention. Letters Patent will be secured upon moderate terms. Applications can be made to the undersigned, personally or by letter post paid. n8 SAMUEL C. HILLS, Patent Agent.

PREMIUM SLIDE LATHES.

THE subscriber is constantly building his improved Lathes of all sizes, from 7 to 30 feet long, and can execute orders at short notice. JAMES T. PERKINS, Hudson Machine Shop and Iron Works, Hudson, N. Y. m11

Machinery.

PERSONS residing in any part of the United States who are in want of Machines, Engines, Lathes, or ANY DESCRIPTION OF MACHINERY, can have their orders promptly executed by addressing the Publishers of this paper. From an extensive acquaintance among the principal machinists and a long experience in mechanical matters they have uncommon facilities for the selection of the best machinery and will faithfully attend to any business entrusted to their care. MUNN & CO. a15

GURNEY'S PREMIUM DAGUERRIAN GALLERY.—No. 189 Broadway.

The oldest establishment of the kind in the city. All persons wishing a perfectly finished Picture in every respect would find it to their advantage to call and examine the Pictures taken by his New Process and for which the first Premium, a silver medal, was awarded at the late fair of the American Institute for 1848. d16 3m*

Johnson's Improved Shingle Machine.

THE Subscriber having received Letters Patent for an improvement in the Shingle Machine, is now ready to furnish them at short notice, and he would request all those who want a good machine for sawing shingles, to call on him and examine the improvements he has made, as one eighth more shingles can be sawed in the same given time than by any other machine now in use. Manufactured at Augusta, Me. and Albany, N. Y. J. G. JOHNSON. Augusta, Maine, Oct. 28, 1848. o28 1y

Lap welded Wrought Iron Tubes FOR TUBULAR BOILERS.

From 1 1/2 to 6 inches diameter, and any length, not exceeding 17 feet. THESE Tubes are of the same quality and manufacture as those extensively used in England, Scotland, France and Germany, for Locomotive, Marine and other Steam Engine Boilers. THOMAS PROSSER, Patentee, 28 Platt street, New York d30

HARTSON'S FIRST PREMIUM TOOL MANUFACTORY.—42 Gold st N. Y.

WHERE he continues to manufacture at short notice his Superior Turning Lathes, Drilling, Slotting, Bolt and Gear Cutting Machines of all sizes, together with all other tools required in engine and Machine Manufactories. All made in the best possible workman-like manner. Each tool is carefully adjusted before leaving the manufactory. Communications for particulars cheerfully responded to by addressing, (Post paid.) j13 3m. G. B. HARTSON

SAW MANUFACTORY.

LEAVITT & M'DANIEL, Fisherville, N. H., Manufacturers of Mill, Circular, Tennon, Cross-cut, and Pit Saws. Also, Felloe, Turning and Veneering Saws; Billet or Wood Cutter's Saws; Iron or Brass Web Saws, Pruning and Butcher's Bow Saws, Chest, Hand, Panel and Rippling Saws. Also, Plastering Trowels. J. McDaniel, Concord, Wm. D. Leavitt, Fisherville. RUFUS R. LEE, Manufacturers' Agent, No. 11 Kilby st. (up stairs) Boston, Mass. d30 3m*

IMPORTANT TO WOOLEN MANUFACTURERS.

THE subscriber in consequence of declining health is desirous of disposing of his Wool Carding, Dyeing and Cloth Dressing Establishment situated in the Town of West Somers, Westchester Co. N. Y. The building is in good repair and the Machinery in perfect running order with a profitable set of customers. The Establishment pays an excellent profit and affords the best facilities for Country Manufacturing. The only cause for the owner wishing to sell is for the reason above stated. Further information may be obtained by applying to Josiah Fowler No. 20 Beaver st. New York, or by addressing the subscriber (post paid) at Peekskill, N. Y. R. C. VARNEL. j20 4t*

Z. C. Robbins,

Consulting Engineer and Counsellor for Patentees. Office on F street, opposite Patent Office, Washington, D. C. j26 tf

BRICK MACHINE WANTED.

THE subscriber wishes to purchase one or two Brick Moulding Machines of cheap, durable and simple construction. A machine that will mould bricks without the use of dust or sand upon the moulds would be preferred. Persons having such machines for sale address the subscriber at Washington, N. C. (Beaufort County,) giving a description of the same. j27 3t J. B. C. CLARK.

Agricultural Implements.

Inventors and Manufacturers of superior Agricultural Implements may find customers for their goods by applying at the Agricultural Warehouse of S. C. HILLS & CO. 43 Fulton st. n8

A. G. FAY.

MANUFACTURER of Lead Pencils. Graduated Drawing; writing and Stylographic; and Artist's pencils, Crayons, Ever points, Pen Holders &c. The above pencils are peculiarly adapted to Mechanics use, as they possess great firmness and strength of points. Orders solicited from all parts of the country and goods forwarded with despatch. Concord, Mass. j20 tf



For the Scientific American.

Poisonous Metals.—Liquid Tests of Arsenic.

In all medical examinations connected with legal inquiries a preliminary experiment is performed with distilled water, and hydrochloric acid is used to resolve the arsenic, after which the slip of copper foil is introduced. It is a fact, says Noad, of especial importance in a medico legal point of view that a person may have died from the effects of poison and yet not a trace of it be discovered in the stomach or its contents. In such cases where suspicion exists, some of the solid parts of the body, such as the liver and the blood, will have to be examined, and the best manner of preparing these substances for test is described by Fresenius, which is to digest the organic substances in a water bath with an equal weight of concentrated hydrochloric acid and as much water as will give the whole a thin consistence. Chlorate of potassa is then added, in portions of about half a drachm at intervals of about five minutes until the contents have assumed a bright yellow color, perfectly mixed, and of a thin liquid appearance. When this is attained about 2 drachms more of the chlorate of potassa is then added to the mixture and the basin is then removed from the water bath. When cool, it is filtered and the residue washed. This filtrate is then concentrated to about a pint and a quantity of sulphurous acid added to reduce the arsenic acid to arsenious acid to make it more easily precipitated by sulphuretted hydrogen. The excess of sulphurous acid is then driven off by heat, and the fluid exposed to a slow stream of sulphuretted hydrogen gas for about 12 hours. The sulphuret of arsenic thus obtained is washed and treated with fuming nitric acid evaporated to dryness, moistened with pure sulphuric acid and then gently heated, first on the water bath and afterwards at a higher temperature of about 300 degrees, until the mass begins to crumble. The residue is then treated with boiling water, then filtered, and the clear fluid after being again acidified with hydrochloric acid is again precipitated with sulphuretted hydrogen gas.—The pure sulphuret of arsenic thus obtained is mixed with the carbonate of soda and cyanide of potassium, then mixed with charcoal dust and reduced in a tube, when the metal volatilizes and condenses on the cool part of the tube, as has been described in a former article.

All nitrates and various salts of mercury and other metals render the separation of arsenic from a solution, by a copper foil being boiled in said solution, to precipitate the arsenic on the copper—very difficult, next to impossible, and in such cases, the liquid test of Fresenius already described, is the best. It would be well for those who desire a more elaborate treatise to consult the late works of Fresenius and Dr. Turner and M. Rose.

Many may think it morally impossible that a person can be poisoned by arsenic, and the stomach exhibit no traces of the poison at the same time. Yet it is a fact. About 16 years ago there was a very fashionable color called *sage green* employed in the manufacture of cotton gingham. It was principally dyed in the cities of Manchester and Glasgow in Britain, and dyed in the yarn. Arsenious acid dissolved by boiling in water, and the sulphate of copper, precipitated by caustic lye, were the ingredients employed in dyeing this beautiful green color. The precipitate of these ingredients absorbed by the cotton yarn was so fine and powdery and adhered to the fibres so tenaciously, that it was next to impossible to remove the dust by washing in water. Owing to this when the *winders* (mostly old women) were winding the yarn on pirns or bobbins, a great deal of this fine dust was thrown off in the operation and many fell a sacrifice ignorantly to this poison in toiling for their daily bread. A number of weavers

too, had their health seriously injured while weaving the yarn, and it was noticed that no bird, such as canaries, could live in the houses where the yarn was wound from the skeins into bobbins. In every shape it is a dangerous poison, and yet as a pure metal it is said to be harmless and only virulent as an oxide. It was asserted by Orfila that arsenic sometimes existed naturally in the human body, but this was a grave error,—it may exist naturally in the poison of snakes and the effluvia of mad animals, but certainly in no other manner in animated nature that we can conjecture.

To Wash Iron with Gold.

It is said that if sulphuric ether is mixed with the nitro muriate of gold, that the gold will combine with the ether, and become separate from the acid. By taking a camel hair pencil and writing with the ether gold solution on bright steel and then plunging it in cold water, the steel will be coated; where wrote upon, with gold. The steel is afterwards to be heated to as high a degree as possible without changing the color, when the gold may be burnished.

History of the Rotary Engine.

Prepared expressly for the Scientific American.

WITTY'S ROTARY ENGINE.

This is a rotative engine invented and patented in 1810 by Mr R. Witty of Hull, England and described by Galloway and is a substitute merely for the crank—the great object of all rotary engines.

FIG. 39.

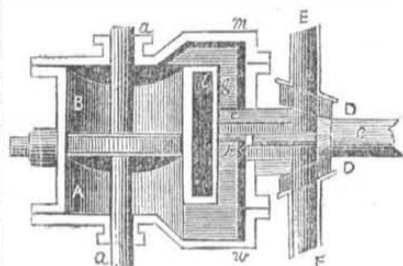
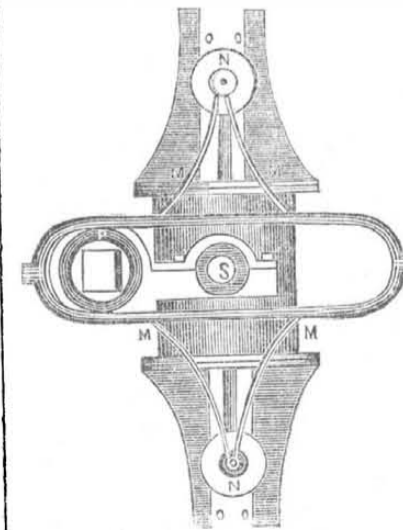

Fig. 39, is the cylinder, shorter and wider, than fixed cylinders, with its piston B, the rod of which works air-tight through the stuffing boxes *a a*, at each end of the cylinder, with a provision at W to blow the air and water at starting when required. The axis or shaft, C C, is fastened at right angles to the cylinder, with screw bolts through flanch I. In the axis are cast or bored two ducts or channels, E F, of sufficient capacity to admit steam to supply the cylinder. The ends of these ducts are securely plugged up. The side pipes, *h* and *g*, are joined to the sides of the axis, and communicate separately with the ducts, E F, in such a manner that the pipe *h* shall communicate with the duct E, and the pipe *g* with the cylinder. D D, is the concentric collar, through which the taper part of the axis works air-tight; to this collar are screwed the steam pipe E and education pipe F; the

FIG. 40.



former leading from the boiler, and the latter to the condenser and exhausting pump. The two holes in the collar, where the two pipes are joined, are made in the form of a parallelogram, so that when the cylinder, side pipes, and shaft, turn round through the collar D D the communications betwixt the boiler and cylinder, and the cylinder and condenser, will be

open alternately during half the revolution, and each side of the piston will be open, or exposed alternately to the steam and the condenser.

FIG. 41.

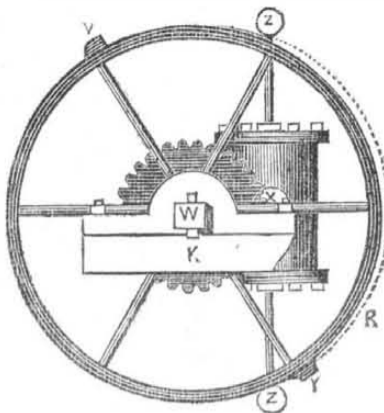

Fig. 40 represents what is called the cardioid motion, attached to the engine. It consists of a parallelogram, frame, or trammel groove, joined to the piston rod by the two triangles M M, M M. The two friction wheels, N N, are hung betwixt the ends of these triangles, and the piston-rod and rim betwixt the side joints O O O, cast or screwed upon the covers of the cylinder. At a distance of half the stroke of the piston from the centre of the cylinder shaft is fixed a strong stud or pin, having a strong knee crank, at right angles from it, to support the gudgeon end of the cylinder shaft at S. On the round part of this stud runs a wheel P, filling the trammel groove, and the square is driven tight into another piece of cast-iron, and keyed fast, and this is bolted down to a beam of wood, as at K, Fig. 41. When the steam is admitted under the piston the trammel groove moves with the piston rod, and is turned from a rectilinear to a rotary direction by the stud P, resting on one side of the trammel, and causes the cylinder to revolve towards the stud, and as it revolves the groove comes perpendicular, or at right angles to the situation in which it is seen in the figure, the cylinder lays horizontal, the piston is at the extremity of its stroke, and the alternations of the steam take place at that instant in the axis. In this position the engine may be said to be passing centres, similar to that of a beam engine, when passing the vertical position of the crank; and thus a continued revolving of the cylinder is effected, while its piston describes a circle, the diameter of which is half the length of the stroke.

Fig. 41 is a contrivance for applying the force of the piston upon a wheel R, or crank, which revolves upon a separate axis at W, placed half the length of the stroke of the piston from the centre of the cylinder shaft X, which is supported by a knee from or through the centre of the wheel, similar to the contrivance for supporting the gudgeon of the cylinder, Fig. 40. The diameter of the wheel is made equal to the length of the piston rod Z; and has its rim made to incline or project, in order that the piston rod may lay hold of it alternately at the stops Y Y.

Chemical Affinity—Definite Proportions.

A remarkable fact relative to chemical affinity is, that the quantity of any substance required to form a particular compound is always the same; and so long as a body retains its general characteristics, it will always consist of the same elements, united together in the same proportions. For instance sulphuric acid (oil of vitriol) is always composed of 16 parts, by weight, of sulphur, and 24 of oxygen. No other substances can form sulphuric acid, nor can its own elements produce it, if combined in any other proportions than those just stated. Water, in like manner, is formed of one part, by weight, of hydrogen, and eight of oxygen; and were these elements to unite in any other proportions, some new substance, different from water would be produced. When two or more elements unite to form a compound, the addition or diminution of a small quantity of one, often produces an effect remarkably different to what would have resulted, had the proportions been different. For instance, there is great dissimilarity, both in taste and appearance, between starch and sugar; and yet they are composed of the same elements, and very nearly in the same propor-

tions, as will be seen by the following analysis:—

	Oxy.	Hy.	Car.
Sugar is composed of	40	5	36
Starch	48	13	42

The figures represent the parts of each element, by weight, that form the two substances; so that it will be seen, it is only in consequence of the starch containing a few more particles of its elements than the sugar does, that it differs so materially in its sensible qualities. If we could abstract a few atoms only of the oxygen, hydrogen, and carbon, from the starch, we should convert it into sugar! and in some chemical processes this is really effected. It is in consequence of the beautiful law of nature we have been describing, that chemists are able to tell exactly how much of any substance is contained in any particular compound; for the quantity is always the same, and when it has been once ascertained, it is known always. For instance, sulphate of magnesia is formed of sulphuric acid and magnesia. If the latter be added to the acid till effervescence ceases, it will be found, that any magnesia thrown into the solution afterwards will not combine with the acid, but will fall to the bottom of the vessel; thereby showing that only a certain quantity of magnesia will combine with the acid, to form good Epsom salts.

To Make a Gold Powder.

Dissolve gold in aqua regia, or 2 parts nitric and 1 of muriatic acid. The leaf gold is best to use for this purpose. Then take cotton and soak up all the nitro muriate of gold, suffer it to dry and afterwards burn it on a saucer. Take up the ashes of the cotton and wash them, allowing the water to settle before pouring off, when a fine gold powder will be found at the bottom of the saucer, which must be dried and can be used afterwards in the arts, such as ornament for leather or paper.

Glass may be drilled like metal by keeping the instrument (a common iron drill) moist with a solution of camphor in turpentine.

Dr. Graves in his Clinical Lectures states, as a very remarkable circumstance, that females are but rarely affected with the defect of stammering.



THE BEST
Mechanical Paper

IN THE WORLD!
FOURTH YEAR OF THE

SCIENTIFIC AMERICAN!

416 Pages of most valuable information, illustrated with upwards of

500 MECHANICAL ENGRAVINGS!

The Scientific American differs entirely from the magazines and papers which flood the country, as it is a Weekly Journal of Art, Science and Mechanics, having for its object the advancement of the INTERESTS OF MECHANICS, MANUFACTURERS and INVENTORS. Each number is illustrated with from five to TEN original ENGRAVINGS OF NEW MECHANICAL INVENTIONS, nearly all of the best inventions which are patented at Washington being illustrated in the Scientific American. It also contains a Weekly List of American Patents; notices of the progress of all Mechanical and Scientific Improvements; practical directions on the construction, management and use of all kinds of MACHINERY, TOOLS, &c. &c.

It is printed with clear type on beautiful paper, and being adapted to binding, the subscriber is possessed, at the end of the year, of a large volume of 416 pages, illustrated with upwards of 500 mechanical engravings.

TERMS: Single subscription, \$2 a year in advance; \$1 for six months. Those who wish to subscribe have only to enclose the amount in a letter, directed to

MUNN & CO.,
Publishers of the Scientific American,
128 Fulton street, New York.

All Letters must be Post Paid.

INDUCEMENTS FOR CLUBBING.

5 copies for 6 months	\$4 00
5 " " 12 " "	\$8 00
10 " " 6 " "	\$7 50
10 " " 12 " "	\$15 00
20 " " 6 " "	\$15 00
20 " " 12 " "	\$30 00

Southern and Western Money taken at par for subscriptions. Post Office Stamps taken at their full value.

A SPLENDID PRESENT!

To any person who will send us Three Subscribers, we will present a copy of the PATENT LAWS OF THE UNITED STATES, together with all the information relative to PATENT OFFICE BUSINESS, including full directions for taking out Patents, method of making the Specifications, Claims, Drawings, Models, buying, selling, and transferring Patent Rights, &c. This is a present of GREAT VALUE, yet may be obtained for nothing, by the reader of this prospectus, if he will take the trouble to get Three Subscribers to the Scientific American. It will be an easy matter to obtain two names besides his own.

MUNN & CO., Scientific American Office, N. Y.