

Power Systems

*Disk drives or solid-state drives for the
8408-44E or 8408-E8E*

IBM

Power Systems

*Disk drives or solid-state drives for the
8408-44E or 8408-E8E*

IBM

Note

Before using this information and the product it supports, read the information in “Safety notices” on page vii, “Notices” on page 111, the *IBM Systems Safety Notices* manual, G229-9054, and the *IBM Environmental Notices and User Guide*, Z125-5823.

This edition applies to IBM Power Systems servers that contain the POWER8 processor and to all associated models.

© Copyright IBM Corporation 2015, 2017.

US Government Users Restricted Rights – Use, duplication or disclosure restricted by GSA ADP Schedule Contract with IBM Corp.

Contents

Safety notices	vii
---------------------------------	------------

Disk drives or solid-state drives for the 8408-44E or 8408-E8E	1
---	----------

Installing a disk drive or solid-state drive in the 8408-44E or 8408-E8E	1
Installing a disk drive in the 8408-44E or 8408-E8E system with the power turned off	1
Preparing the 8408-44E or 8408-E8E system to install a disk drive with the power turned off	1
Installing a disk drive in the 8408-44E or 8408-E8E system with the power turned off	4
Preparing the 8408-44E or 8408-E8E system for operation after installing a disk drive with the power turned off	6
Installing a solid-state drive in the 8408-44E or 8408-E8E system with the power turned off	6
Preparing the 8408-44E or 8408-E8E system to install a solid-state drive with the power turned off	7
Installing a solid-state drive in the 8408-44E or 8408-E8E system with the power turned off	10
Preparing the 8408-44E or 8408-E8E system for operation after installing a solid-state drive with the power turned off	11
Installing a disk drive or SSD in the 8408-44E or 8408-E8E system with the power turned on	12
Installing a disk drive or solid-state drive in the 8408-44E or 8408-E8E system with the power turned on in AIX	12
Preparing the 8408-44E or 8408-E8E system to install a disk drive or solid-state drive with the power turned on in AIX	12
Installing a disk drive or SSD in the 8408-44E or 8408-E8E system with the power turned on in AIX	14
Preparing the 8408-44E or 8408-E8E system for operation after installing a disk drive or solid-state drive with the power turned on in AIX	17
Installing a disk drive or SSD in the 8408-44E or 8408-E8E system with the power turned on in Linux	18
Preparing the 8408-44E or 8408-E8E system to install a disk drive or SSD with the power turned on in Linux	18
Installing a disk drive or SSD in the 8408-44E or 8408-E8E system with the power turned on in Linux	20
Preparing the 8408-44E or 8408-E8E system for operation after installing a disk drive or SSD with the power turned on in Linux	23
Removing and replacing a disk drive or solid-state drive in the 8408-44E or 8408-E8E	24
Removing and replacing a disk drive or solid-state drive in the 8408-44E or 8408-E8E with the system power turned off	24
Preparing the 8408-44E or 8408-E8E system to remove and replace a disk drive or solid-state drive with the power turned off	25
Removing a disk drive or SSD from the 8408-44E or 8408-E8E system	27
Replacing a disk drive or SSD in the 8408-44E or 8408-E8E system	29
Preparing the 8408-44E or 8408-E8E system for operation after removing and replacing a disk drive or SSD with the power turned off	31
Removing and replacing a disk drive or SSD in the 8408-44E or 8408-E8E system with the power turned on in AIX	32
Preparing the 8408-44E or 8408-E8E system to remove and replace a disk drive or SSD with the power turned on in AIX	32
Removing a disk drive or SSD from the 8408-44E or 8408-E8E system with the power turned on in AIX	34
Replacing a disk drive or SSD in the 8408-44E or 8408-E8E system with the power turned on in AIX	36
Preparing the 8408-44E or 8408-E8E system for operation after replacing a drive with the power turned on in AIX	38
Removing and replacing a disk drive or SSD in the 8408-44E or 8408-E8E with the power turned on in Linux	38
Preparing the 8408-44E or 8408-E8E system to remove and replace a disk drive or SSD with the power turned on in Linux	39
Removing a disk drive or SSD from the 8408-44E or 8408-E8E system with the power turned on in Linux	43
Replacing a disk drive or SSD in the 8408-44E or 8408-E8E system with the power turned on in Linux	45
Preparing the 8408-44E or 8408-E8E system for operation after removing and replacing a drive with the power turned on in Linux	48
Related procedures for installing, removing, and replacing disk drives or solid-state drives.	49
Removing and installing a disk drive filler	49
Removing a disk drive filler from the 8408-44E or 8408-E8E	49

Installing a disk drive filler in the 8408-44E or 8408-E8E system	50
Disk drive or solid-state drive locations and service indicators	51
Disk drive and SSD locations and service indicators for the 8408-44E or 8408-E8E system	52
Disk drive locations and service indicators for the 5887 disk drive enclosure	52
Disk drive locations and service indicators for the ESLL and ESLS storage enclosures	53
Solid-state drive configuration rules	55
Mainstream solid-state drives	58
Using the AIX fuel gauge command	60
Using the IBM i fuel gauge tool	61
Using the Linux fuel gauge command	62
Preparing the system to remove a disk drive or solid-state drive	63
Preparing the system to remove a disk drive or solid-state drive in AIX	63
Preparing the system to remove a disk drive or solid-state drive from a system or logical partition controlled by IBM i.	63
Preparing the system to remove a disk drive or solid-state drive in Linux	64
Configuring a disk drive or solid-state drive	64
Configuring a disk drive or solid-state drive for use in an AIX system or AIX logical partition	64
Configuring a disk drive or solid-state drive for use in an IBM i system or IBM i logical partition	64
Configuring a disk drive or solid-state drive on a load source adapter for hot-spare protection by using the IBM i operating system	66
Configuring a disk drive or solid-state drive for use in an Linux system or Linux logical partition	67
Determining the disk drive or solid-state drive protection status in the IBM i operating system	67
Rebuilding data on a replacement disk drive or solid-state drive	68
Rebuilding data on a replacement disk drive or solid-state drive in a system or logical partition running the AIX operating system	68
Rebuilding data on a replacement disk drive or solid-state drive in a system or logical partition running the IBM i operating system	68
Rebuilding data on a replacement disk drive or solid-state drive in a system or logical partition that is running the Linux operating system	69
Rebuilding data by using the iprconfig command	70

Common procedures for installing, removing and replacing disk drives or solid-state drives 73

Before you begin	73
Identifying a part	76
Identifying the enclosure or server that contains the part	76
Enabling enclosure or server indicators with the ASMI	76
Control panel LEDs.	76
Activating an identify LED for an enclosure or server by using the HMC.	77
Finding the part location code and LED support status.	78
Identifying a part by using the operating system or VIOS	79
Identifying a part in an AIX system or logical partition.	79
Finding the location code for a part in an AIX system or logical partition.	79
Activating the indicator light for a part by using AIX diagnostics	79
Identifying a part in an IBM i system or logical partition	80
Finding the location code and activating the indicator light for a part by using the IBM i operating system	80
Identifying a part in a Linux system or logical partition	81
Finding the location code of a part in a Linux system or logical partition.	81
Activating the indicator light for a part by using the Linux operating system	81
Identifying a part in a VIOS system or logical partition.	81
Finding the location code of a part in a VIOS system or logical partition	81
Activating the indicator light for a part by using the VIOS tools.	82
Identifying a part by using the ASMI.	82
Activating the identify LED by using the ASMI when you know the location code	82
Activating the identify LED by using the ASMI when you do not know the location code	83
Identifying a part by using the HMC.	83
Stopping a system or logical partition	84
Stopping a system that is not managed by an HMC	84
Stopping a system by using the control panel	84
Stopping a system by using the ASMI	85

Stopping a system by using the HMC	85
Stopping a system by using the HMC Classic or HMC Enhanced interface	85
Stopping a system by using the HMC Enhanced + Tech Preview (Pre-GA) or HMC Enhanced+ interface	86
Stopping an IBM PowerKVM system	86
Starting the system or logical partition	86
Starting a system that is not managed by an HMC	86
Starting a system by using the control panel	87
Starting a system by using the ASMI	88
Starting a system or logical partition by using the HMC	88
Starting a system or logical partition by using the HMC Classic or HMC Enhanced interface	88
Starting a system or logical partition by using the HMC Enhanced + Tech Preview (Pre-GA) or HMC Enhanced+ interface	89
Starting an IBM PowerKVM system	89
Installing or replacing a part with an HMC	90
Installing a part by using the HMC	90
Removing a part by using the HMC	90
Repairing a part by using the HMC	91
Power cords	92
Disconnecting the power cords from the system	92
Connecting the power cords to the system	95
Removing and replacing covers on an 8408-44E or 8408-E8E system	98
Removing the front cover from an 8408-44E or 8408-E8E system	98
Installing the front cover on an 8408-44E or 8408-E8E system	98
Removing the service access cover from an 8408-44E or 8408-E8E system	99
Installing the service access cover on an 8408-44E or 8408-E8E system	100
Removing and replacing the safety cover in an 8408-44E or 8408-E8E system	101
Removing the safety cover from an 8408-44E or 8408-E8E system	101
Replacing the safety cover in an 8408-44E or 8408-E8E system	102
Opening and closing the I/O latch in an 8408-44E or 8408-E8E system	103
Opening the I/O latch in an 8408-44E or 8408-E8E system	103
Closing the I/O latch in an 8408-44E or 8408-E8E system	104
Deactivating an identify LED	105
Deactivating a system attention LED by using the operating system or VIOS tools	105
Deactivating the indicator light for a part by using AIX diagnostics	105
Deactivating the indicator light by using the IBM i operating system	106
Deactivating the indicator light by using the Linux operating system	106
Deactivating the indicator light for a part by using the VIOS tools	106
Deactivating a system attention LED by using the ASMI	107
Deactivating the identify LED by using the ASMI when you know the location code	107
Deactivating the identify LED by using the ASMI when you do not know the location code	107
Deactivating a check log indicator (system information indicator) by using the ASMI	108
Deactivating LEDs by using the HMC	108
Deactivating a system attention LED or partition LED by using the HMC	108
Deactivating an identify LED for a FRU by using the HMC	109
Deactivating an identify LED for an enclosure by using the HMC	109
Notices	111
Accessibility features for IBM Power Systems servers	112
Privacy policy considerations	113
Trademarks	114
Electronic emission notices	114
Class A Notices	114
Class B Notices	118
Terms and conditions	121

Safety notices

Safety notices may be printed throughout this guide:

- **DANGER** notices call attention to a situation that is potentially lethal or extremely hazardous to people.
- **CAUTION** notices call attention to a situation that is potentially hazardous to people because of some existing condition.
- **Attention** notices call attention to the possibility of damage to a program, device, system, or data.

World Trade safety information

Several countries require the safety information contained in product publications to be presented in their national languages. If this requirement applies to your country, safety information documentation is included in the publications package (such as in printed documentation, on DVD, or as part of the product) shipped with the product. The documentation contains the safety information in your national language with references to the U.S. English source. Before using a U.S. English publication to install, operate, or service this product, you must first become familiar with the related safety information documentation. You should also refer to the safety information documentation any time you do not clearly understand any safety information in the U.S. English publications.

Replacement or additional copies of safety information documentation can be obtained by calling the IBM Hotline at 1-800-300-8751.

German safety information

Das Produkt ist nicht für den Einsatz an Bildschirmarbeitsplätzen im Sinne § 2 der Bildschirmarbeitsverordnung geeignet.

Laser safety information

IBM® servers can use I/O cards or features that are fiber-optic based and that utilize lasers or LEDs.

Laser compliance

IBM servers may be installed inside or outside of an IT equipment rack.

DANGER: When working on or around the system, observe the following precautions:

Electrical voltage and current from power, telephone, and communication cables are hazardous. To avoid a shock hazard:

- If IBM supplied the power cord(s), connect power to this unit only with the IBM provided power cord. Do not use the IBM provided power cord for any other product.
- Do not open or service any power supply assembly.
- Do not connect or disconnect any cables or perform installation, maintenance, or reconfiguration of this product during an electrical storm.
- The product might be equipped with multiple power cords. To remove all hazardous voltages, disconnect all power cords.
 - For AC power, disconnect all power cords from their AC power source.
 - For racks with a DC power distribution panel (PDP), disconnect the customer's DC power source to the PDP.
- When connecting power to the product ensure all power cables are properly connected.

- For racks with AC power, connect all power cords to a properly wired and grounded electrical outlet. Ensure that the outlet supplies proper voltage and phase rotation according to the system rating plate.
- For racks with a DC power distribution panel (PDP), connect the customer's DC power source to the PDP. Ensure that the proper polarity is used when attaching the DC power and DC power return wiring.
- Connect any equipment that will be attached to this product to properly wired outlets.
- When possible, use one hand only to connect or disconnect signal cables.
- Never turn on any equipment when there is evidence of fire, water, or structural damage.
- Do not attempt to switch on power to the machine until all possible unsafe conditions are corrected.
- Assume that an electrical safety hazard is present. Perform all continuity, grounding, and power checks specified during the subsystem installation procedures to ensure that the machine meets safety requirements.
- Do not continue with the inspection if any unsafe conditions are present.
- Before you open the device covers, unless instructed otherwise in the installation and configuration procedures: Disconnect the attached AC power cords, turn off the applicable circuit breakers located in the rack power distribution panel (PDP), and disconnect any telecommunications systems, networks, and modems.

DANGER:

- Connect and disconnect cables as described in the following procedures when installing, moving, or opening covers on this product or attached devices.

To Disconnect:

1. Turn off everything (unless instructed otherwise).
2. For AC power, remove the power cords from the outlets.
3. For racks with a DC power distribution panel (PDP), turn off the circuit breakers located in the PDP and remove the power from the Customer's DC power source.
4. Remove the signal cables from the connectors.
5. Remove all cables from the devices.

To Connect:

1. Turn off everything (unless instructed otherwise).
2. Attach all cables to the devices.
3. Attach the signal cables to the connectors.
4. For AC power, attach the power cords to the outlets.
5. For racks with a DC power distribution panel (PDP), restore the power from the Customer's DC power source and turn on the circuit breakers located in the PDP.
6. Turn on the devices.

Sharp edges, corners and joints may be present in and around the system. Use care when handling equipment to avoid cuts, scrapes and pinching. (D005)

(R001 part 1 of 2):

DANGER: Observe the following precautions when working on or around your IT rack system:

- Heavy equipment—personal injury or equipment damage might result if mishandled.
- Always lower the leveling pads on the rack cabinet.
- Always install stabilizer brackets on the rack cabinet.
- To avoid hazardous conditions due to uneven mechanical loading, always install the heaviest devices in the bottom of the rack cabinet. Always install servers and optional devices starting from the bottom of the rack cabinet.
- Rack-mounted devices are not to be used as shelves or work spaces. Do not place objects on top of rack-mounted devices. In addition, do not lean on rack mounted devices and do not use them to stabilize your body position (for example, when working from a ladder).



- Each rack cabinet might have more than one power cord.
 - For AC powered racks, be sure to disconnect all power cords in the rack cabinet when directed to disconnect power during servicing.
 - For racks with a DC power distribution panel (PDP), turn off the circuit breaker that controls the power to the system unit(s), or disconnect the customer's DC power source, when directed to disconnect power during servicing.
- Connect all devices installed in a rack cabinet to power devices installed in the same rack cabinet. Do not plug a power cord from a device installed in one rack cabinet into a power device installed in a different rack cabinet.
- An electrical outlet that is not correctly wired could place hazardous voltage on the metal parts of the system or the devices that attach to the system. It is the responsibility of the customer to ensure that the outlet is correctly wired and grounded to prevent an electrical shock.

(R001 part 2 of 2):

CAUTION:

- Do not install a unit in a rack where the internal rack ambient temperatures will exceed the manufacturer's recommended ambient temperature for all your rack-mounted devices.
- Do not install a unit in a rack where the air flow is compromised. Ensure that air flow is not blocked or reduced on any side, front, or back of a unit used for air flow through the unit.
- Consideration should be given to the connection of the equipment to the supply circuit so that overloading of the circuits does not compromise the supply wiring or overcurrent protection. To provide the correct power connection to a rack, refer to the rating labels located on the equipment in the rack to determine the total power requirement of the supply circuit.
- *(For sliding drawers.)* Do not pull out or install any drawer or feature if the rack stabilizer brackets are not attached to the rack. Do not pull out more than one drawer at a time. The rack might become unstable if you pull out more than one drawer at a time.



- *(For fixed drawers.)* This drawer is a fixed drawer and must not be moved for servicing unless specified by the manufacturer. Attempting to move the drawer partially or completely out of the rack might cause the rack to become unstable or cause the drawer to fall out of the rack.

CAUTION:

Removing components from the upper positions in the rack cabinet improves rack stability during relocation. Follow these general guidelines whenever you relocate a populated rack cabinet within a room or building.

- Reduce the weight of the rack cabinet by removing equipment starting at the top of the rack cabinet. When possible, restore the rack cabinet to the configuration of the rack cabinet as you received it. If this configuration is not known, you must observe the following precautions:
 - Remove all devices in the 32U position (compliance ID RACK-001 or 22U (compliance ID RR001) and above.
 - Ensure that the heaviest devices are installed in the bottom of the rack cabinet.
 - Ensure that there are little-to-no empty U-levels between devices installed in the rack cabinet below the 32U (compliance ID RACK-001 or 22U (compliance ID RR001) level, unless the received configuration specifically allowed it.
- If the rack cabinet you are relocating is part of a suite of rack cabinets, detach the rack cabinet from the suite.
- If the rack cabinet you are relocating was supplied with removable outriggers they must be reinstalled before the cabinet is relocated.
- Inspect the route that you plan to take to eliminate potential hazards.
- Verify that the route that you choose can support the weight of the loaded rack cabinet. Refer to the documentation that comes with your rack cabinet for the weight of a loaded rack cabinet.
- Verify that all door openings are at least 760 x 230 mm (30 x 80 in.).
- Ensure that all devices, shelves, drawers, doors, and cables are secure.
- Ensure that the four leveling pads are raised to their highest position.
- Ensure that there is no stabilizer bracket installed on the rack cabinet during movement.
- Do not use a ramp inclined at more than 10 degrees.
- When the rack cabinet is in the new location, complete the following steps:
 - Lower the four leveling pads.
 - Install stabilizer brackets on the rack cabinet.
 - If you removed any devices from the rack cabinet, repopulate the rack cabinet from the lowest position to the highest position.
- If a long-distance relocation is required, restore the rack cabinet to the configuration of the rack cabinet as you received it. Pack the rack cabinet in the original packaging material, or equivalent. Also lower the leveling pads to raise the casters off of the pallet and bolt the rack cabinet to the pallet.

(R002)

(L001)



DANGER: Hazardous voltage, current, or energy levels are present inside any component that has this label attached. Do not open any cover or barrier that contains this label. (L001)

(L002)



DANGER: Rack-mounted devices are not to be used as shelves or work spaces. (L002)

(L003)



or



or



or



or

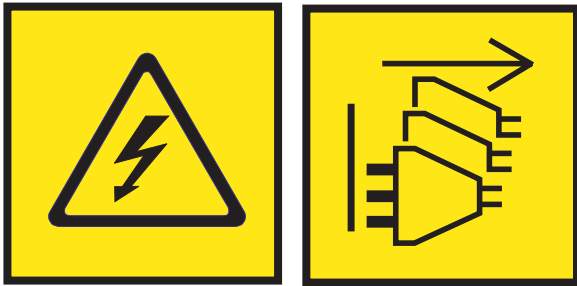

DANGER: Multiple power cords. The product might be equipped with multiple AC power cords or multiple DC power cables. To remove all hazardous voltages, disconnect all power cords and power cables. (L003)

(L007)



CAUTION: A hot surface nearby. (L007)

(L008)



CAUTION: Hazardous moving parts nearby. (L008)

All lasers are certified in the U.S. to conform to the requirements of DHHS 21 CFR Subchapter J for class 1 laser products. Outside the U.S., they are certified to be in compliance with IEC 60825 as a class 1 laser product. Consult the label on each part for laser certification numbers and approval information.

CAUTION:

This product might contain one or more of the following devices: CD-ROM drive, DVD-ROM drive, DVD-RAM drive, or laser module, which are Class 1 laser products. Note the following information:

- **Do not remove the covers. Removing the covers of the laser product could result in exposure to hazardous laser radiation. There are no serviceable parts inside the device.**
- **Use of the controls or adjustments or performance of procedures other than those specified herein might result in hazardous radiation exposure.**

(C026)

CAUTION:

Data processing environments can contain equipment transmitting on system links with laser modules that operate at greater than Class 1 power levels. For this reason, never look into the end of an optical fiber cable or open receptacle. Although shining light into one end and looking into the other end of a disconnected optical fiber to verify the continuity of optic fibers many not injure the eye, this procedure is potentially dangerous. Therefore, verifying the continuity of optical fibers by shining light into one end and looking at the other end is not recommended. To verify continuity of a fiber optic cable, use an optical light source and power meter. (C027)

CAUTION:

This product contains a Class 1M laser. Do not view directly with optical instruments. (C028)

CAUTION:

Some laser products contain an embedded Class 3A or Class 3B laser diode. Note the following information: laser radiation when open. Do not stare into the beam, do not view directly with optical instruments, and avoid direct exposure to the beam. (C030)

CAUTION:

The battery contains lithium. To avoid possible explosion, do not burn or charge the battery.

Do Not:

- **Throw or immerse into water**
- **Heat to more than 100°C (212°F)**
- **Repair or disassemble**

Exchange only with the IBM-approved part. Recycle or discard the battery as instructed by local regulations. In the United States, IBM has a process for the collection of this battery. For information, call 1-800-426-4333. Have the IBM part number for the battery unit available when you call. (C003)

CAUTION:

Regarding IBM provided VENDOR LIFT TOOL:

- Operation of LIFT TOOL by authorized personnel only.
- LIFT TOOL intended for use to assist, lift, install, remove units (load) up into rack elevations. It is not to be used loaded transporting over major ramps nor as a replacement for such designated tools like pallet jacks, walkies, fork trucks and such related relocation practices. When this is not practicable, specially trained persons or services must be used (for instance, riggers or movers).
- Read and completely understand the contents of LIFT TOOL operator's manual before using. Failure to read, understand, obey safety rules, and follow instructions may result in property damage and/or personal injury. If there are questions, contact the vendor's service and support. Local paper manual must remain with machine in provided storage sleeve area. Latest revision manual available on vendor's web site.
- Test verify stabilizer brake function before each use. Do not over-force moving or rolling the LIFT TOOL with stabilizer brake engaged.
- Do not move LIFT TOOL while platform is raised, except for minor positioning.
- Do not exceed rated load capacity. See LOAD CAPACITY CHART regarding maximum loads at center versus edge of extended platform.
- Only raise load if properly centered on platform. Do not place more than 200 lb (91 kg) on edge of sliding platform shelf also considering the load's center of mass/gravity (CoG).
- Do not corner load the platform tilt riser accessory option. Secure platform riser tilt option to main shelf in all four (4x) locations with provided hardware only, prior to use. Load objects are designed to slide on/off smooth platforms without appreciable force, so take care not to push or lean. Keep riser tilt option flat at all times except for final minor adjustment when needed.
- Do not stand under overhanging load.
- Do not use on uneven surface, incline or decline (major ramps).
- Do not stack loads.
- Do not operate while under the influence of drugs or alcohol.
- Do not support ladder against LIFT TOOL.
- Tipping hazard. Do not push or lean against load with raised platform.
- Do not use as a personnel lifting platform or step. No riders.
- Do not stand on any part of lift. Not a step.
- Do not climb on mast.
- Do not operate a damaged or malfunctioning LIFT TOOL machine.
- Crush and pinch point hazard below platform. Only lower load in areas clear of personnel and obstructions. Keep hands and feet clear during operation.
- No Forks. Never lift or move bare LIFT TOOL MACHINE with pallet truck, jack or fork lift.
- Mast extends higher than platform. Be aware of ceiling height, cable trays, sprinklers, lights, and other overhead objects.
- Do not leave LIFT TOOL machine unattended with an elevated load.
- Watch and keep hands, fingers, and clothing clear when equipment is in motion.
- Turn Winch with hand power only. If winch handle cannot be cranked easily with one hand, it is probably over-loaded. Do not continue to turn winch past top or bottom of platform travel. Excessive unwinding will detach handle and damage cable. Always hold handle when lowering, unwinding. Always assure self that winch is holding load before releasing winch handle.
- A winch accident could cause serious injury. Not for moving humans. Make certain clicking sound is heard as the equipment is being raised. Be sure winch is locked in position before releasing handle. Read instruction page before operating this winch. Never allow winch to unwind freely. Freewheeling will cause uneven cable wrapping around winch drum, damage cable, and may cause serious injury. (C048)

Power and cabling information for NEBS (Network Equipment-Building System) GR-1089-CORE

The following comments apply to the IBM servers that have been designated as conforming to NEBS (Network Equipment-Building System) GR-1089-CORE:

The equipment is suitable for installation in the following:

- Network telecommunications facilities
- Locations where the NEC (National Electrical Code) applies

The intrabuilding ports of this equipment are suitable for connection to intrabuilding or unexposed wiring or cabling only. The intrabuilding ports of this equipment *must not* be metalically connected to the interfaces that connect to the OSP (outside plant) or its wiring. These interfaces are designed for use as intrabuilding interfaces only (Type 2 or Type 4 ports as described in GR-1089-CORE) and require isolation from the exposed OSP cabling. The addition of primary protectors is not sufficient protection to connect these interfaces metalically to OSP wiring.

Note: All Ethernet cables must be shielded and grounded at both ends.

The ac-powered system does not require the use of an external surge protection device (SPD).

The dc-powered system employs an isolated DC return (DC-I) design. The DC battery return terminal *shall not* be connected to the chassis or frame ground.

The dc-powered system is intended to be installed in a common bonding network (CBN) as described in GR-1089-CORE.

Disk drives or solid-state drives for the 8408-44E or 8408-E8E

Learn how to install, remove, and replace disk drives or solid-state drives (SSDs) in the IBM Power® System E850 (8408-44E and 8408-E8E) systems.

If you are installing, removing, or replacing mainstream SSDs, it is not supported to mix mainstream drives with enterprise drives in disk arrays. Also, you will need to monitor the amount of life that is remaining in the mainstream drives. For more information about these drives, see “Mainstream solid-state drives” on page 58.

Installing a disk drive or solid-state drive in the 8408-44E or 8408-E8E

Find information about installing a serial-attached SCSI (SAS) disk drive or a solid-state drive (SSD) in the system.

If you are installing a disk drive or solid-state drive in a 5887 disk drive enclosure or 5147-024, ESLL, or ESLS storage enclosure, see *Installing a disk drive or solid-state drive in the 5887 disk drive enclosure*(http://www.ibm.com/support/knowledgecenter/POWER8/p8hal/p8hal_5887_install_kickoff.htm) or *Installing a disk drive or solid-state drive in the 5147-024, ESLL, or ESLS storage enclosure*(http://www.ibm.com/support/knowledgecenter/POWER8/p8hal/p8hal_eslx_install_kickoff.htm).

Installing a disk drive in the 8408-44E or 8408-E8E system with the power turned off

Learn how to install a disk drive in a system with the system power turned off.

Before you install a feature, ensure that the software that is required to support the feature is installed on your system. For information about software prerequisites, see the IBM Prerequisite website (http://www-912.ibm.com/e_dir/eServerPrereq.nsf). If the required software is not installed, see the following websites to download it, and then install it before you continue:

- To download system firmware updates, software updates, and fix packs, see the Fix Central website (<http://www.ibm.com/support/fixcentral/>).
- To download Hardware Management Console (HMC) updates and fixes, see the Hardware Management Console Support and downloads website (www14.software.ibm.com/webapp/set2/sas/f/hmcl/home.html).

To install a disk drive or solid-state drive in a system, complete the following steps:

1. “Preparing the 8408-44E or 8408-E8E system to install a disk drive with the power turned off”
2. “Installing a disk drive in the 8408-44E or 8408-E8E system with the power turned off” on page 4
3. “Preparing the 8408-44E or 8408-E8E system for operation after installing a disk drive with the power turned off” on page 6.

Note: Installing this feature is a customer task. You can complete this task yourself, or contact a service provider to complete the task for you. You might be charged a fee by the service provider for this service.

Preparing the 8408-44E or 8408-E8E system to install a disk drive with the power turned off

Learn about the steps you must complete before you install a disk drive in the system with the system power turned off.

To prepare the system to install a disk drive, complete the following steps:

1. Ensure that the software that is required to support the feature is installed on your system. For information about software prerequisites, see the IBM Prerequisite website (http://www-912.ibm.com/e_dir/eServerPrereq.nsf). If the required system firmware, software, or fix packs are not installed on your system, go to the Fix Central website (<http://www.ibm.com/support/fixcentral/>) to download and install them before you continue.
2. Determine the slot in which you want to install a disk drive. The disk drive slots are in the front of a system.

Figure 1 shows the disk drive locations and service indicators. Service indicators are located above the latch handle on the disk drives.

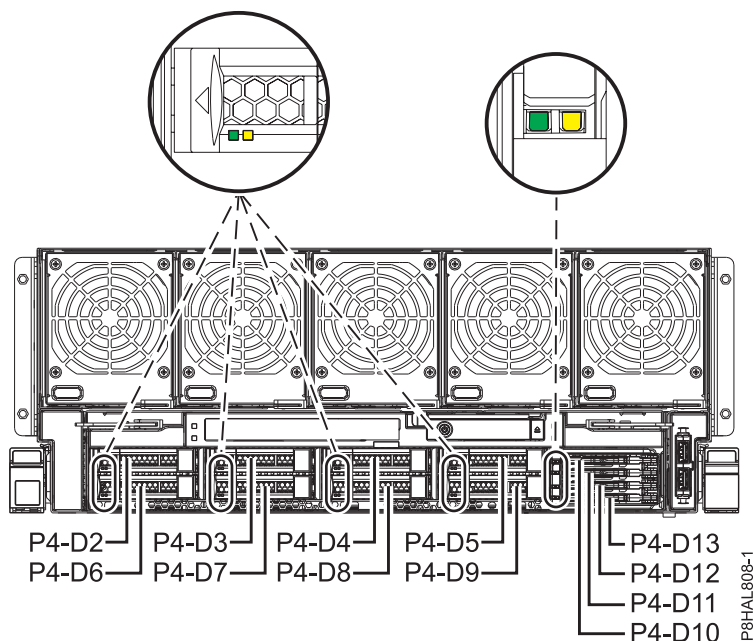

Figure 1. Disk drive and service indicator locations for the system

Note: When you have drive slots available in a system, enclosure, or expansion unit, fill the slot positions in the system first. However, you can choose a different disk drive or solid-state drive placement that depends on your data protection strategy.

3. Record the position (an available empty slot) where the new disk drive must be installed. For example, the next available disk drive or SSD slot might be P4-D3.
4. Stop the system or logical partition. For instructions, see “Stopping a system or logical partition” on page 84.
5. Open the rack rear door.
6. Attach the electrostatic discharge (ESD) wrist strap.

Attention:

- Attach an electrostatic discharge (ESD) wrist strap to the front ESD jack, to the rear ESD jack, or to an unpainted metal surface of your hardware to prevent the electrostatic discharge from damaging your hardware.
 - When you use an ESD wrist strap, follow all electrical safety procedures. An ESD wrist strap is used for static control. It does not increase or decrease your risk of receiving electric shock when using or working on electrical equipment.
 - If you do not have an ESD wrist strap, just prior to removing the product from ESD packaging and installing or replacing hardware, touch an unpainted metal surface of the system for a minimum of 5 seconds.
7. Disconnect the power source from the system by unplugging the system. For instructions, see “Disconnecting the power cords from the system” on page 92.

Note: The system might be equipped with redundant power supply. Before you continue with this procedure, ensure that all power to your system is disconnected.

(L003)

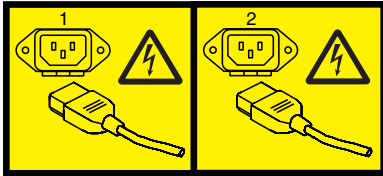

or



or



or

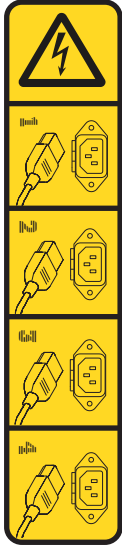

OR

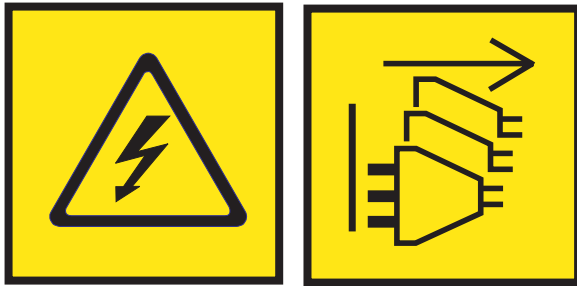

DANGER: Multiple power cords. The product might be equipped with multiple AC power cords or multiple DC power cables. To remove all hazardous voltages, disconnect all power cords and power cables. (L003)

8. Find the package that contains the new drive.

Attention: Drives are fragile. Handle with care.

9. Remove the drive from the static-protective package and place it on an ESD mat.

Installing a disk drive in the 8408-44E or 8408-E8E system with the power turned off

To install a disk drive in the system, complete the steps in this procedure.

Procedure

1. Ensure that you have the electrostatic discharge (ESD) wrist strap attached. If not, attach it now.
2. If the slot you want to use contains a drive filler, remove the drive filler from the slot.

To remove a filler from an 8408-44E or 8408-E8E system, complete the following steps:

- a. Push the lock (A) on the handle of the filler in the direction that is shown in Figure 2 on page 5.
- b. Hold the handle and pull out the filler from the slot.

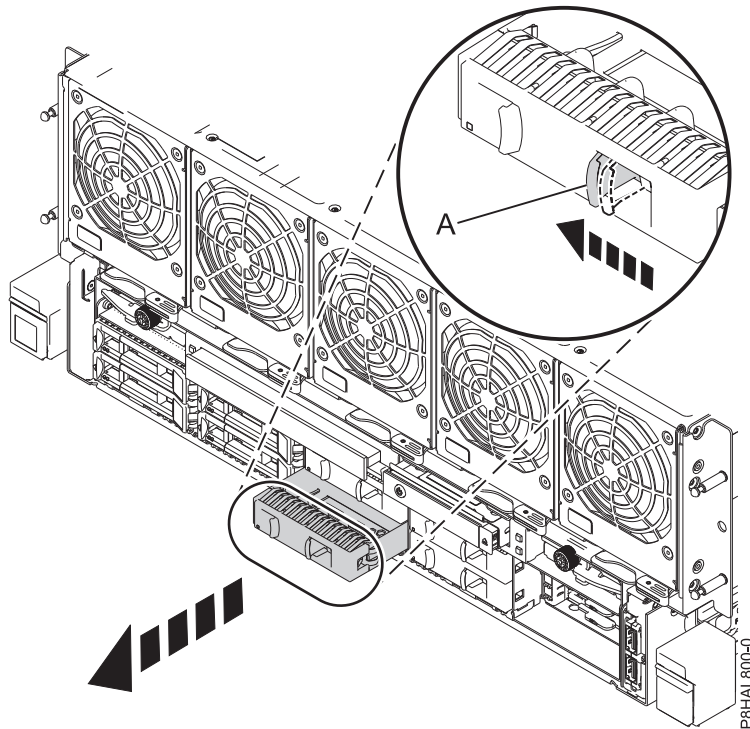

Figure 2. Removing a disk drive filler from an 8408-44E or 8408-E8E system

3. Unlock the drive bay handle (A) by pressing it and pulling it out toward you. If the handle is not all the way out, the drive does not slide into the system. See Figure 3 on page 6.
4. Hold the drive by the top and bottom edges as you position the drive, and insert it into the drive slot.
5. Slide the drive all the way into the system, and push the drive bay handle (A) in until it locks, as shown in Figure 3 on page 6.

Important: Ensure that the drive is fully seated and is all the way into the system.

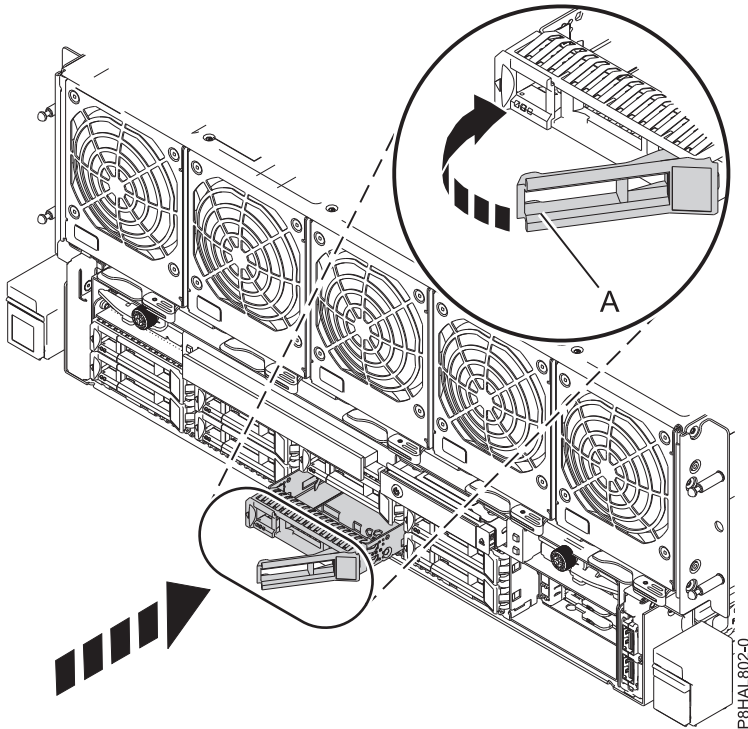

Figure 3. Installing a disk drive in an 8408-44E or 8408-E8E system

6. If you are installing more than one drive, repeat the steps in this procedure until all drives are installed.

Preparing the 8408-44E or 8408-E8E system for operation after installing a disk drive with the power turned off

Learn to prepare the system for operation after you install a disk drive in the system with the system power turned off.

To prepare the system for operation, complete the following steps:

1. Ensure that you have the electrostatic discharge (ESD) wrist strap attached. If not, attach it now.
2. Reconnect the power cords to the system. For instructions, see “Connecting the power cords to the system” on page 95.
3. Start the system or logical partition. For instructions, see “Starting the system or logical partition” on page 86.
4. On the front of the system, verify that the power LED is **ON** (green) for the installed or replaced drive.
5. To configure the newly installed disk drive or solid-state drive, see the following procedures for the applicable operating system that controls the disk drive or solid-state drive:
 - “Configuring a disk drive or solid-state drive for use in an AIX system or AIX logical partition” on page 64.
 - “Configuring a disk drive or solid-state drive for use in an Linux system or Linux logical partition” on page 67.

Installing a solid-state drive in the 8408-44E or 8408-E8E system with the power turned off

Learn how to install a solid-state drive (SSD) in a system with the system power turned off.

Before you install a feature, ensure that the software that is required to support the feature is installed on your system. For information about software prerequisites, see the IBM Prerequisite website (http://www-912.ibm.com/e_dir/eServerPrereq.nsf). If the required software is not installed, see the following websites to download it, and then install it before you continue:

- To download system firmware updates, software updates, and fix packs, see the Fix Central website (<http://www.ibm.com/support/fixcentral/>).
- To download Hardware Management Console (HMC) updates and fixes, see the Hardware Management Console Support and downloads website (www14.software.ibm.com/webapp/set2/sas/f/hmcl/home.html).

To install a solid-state drive in a system, complete the following steps:

1. “Preparing the 8408-44E or 8408-E8E system to install a solid-state drive with the power turned off.”
2. “Installing a solid-state drive in the 8408-44E or 8408-E8E system with the power turned off” on page 10.
3. “Preparing the 8408-44E or 8408-E8E system for operation after installing a solid-state drive with the power turned off” on page 11.

Note: Installing this feature is a customer task. You can complete this task yourself, or contact a service provider to complete the task for you. You might be charged a fee by the service provider for this service.

Preparing the 8408-44E or 8408-E8E system to install a solid-state drive with the power turned off

Learn about the steps you must complete before you install a solid-state drive (SSD) in the system with the system power turned off.

Review the SSD configuration rules and then return here. For information, see “Solid-state drive configuration rules” on page 55.

To prepare the system to install a solid-state drive, complete the following steps:

1. Ensure that the software that is required to support the feature is installed on your system. For information about software prerequisites, see the IBM Prerequisite website (http://www-912.ibm.com/e_dir/eServerPrereq.nsf). If the required system firmware, software, or fix packs are not installed on your system, go to the Fix Central website (<http://www.ibm.com/support/fixcentral/>) to download and install them before you continue.
2. Determine the slot in which you want to install a solid-state drive. The SSD slots are in the front of a system.

Figure 4 on page 8 shows the solid-state drive locations and service indicators. Service indicators are located above the latch handle on the disk drives.

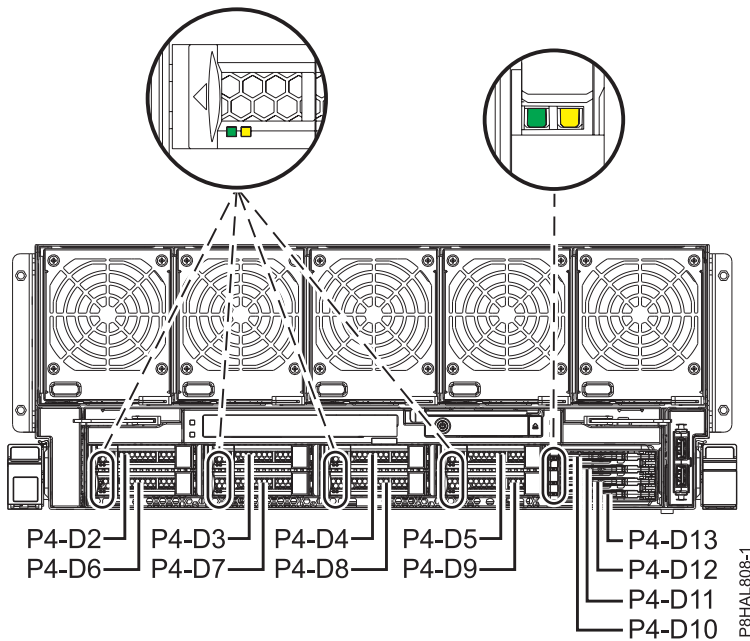

Figure 4. Solid-state drive locations and service indicators for the system

Note: When you have drive slots available in a system, enclosure, or expansion unit, fill the slot positions in the system first. However, you can choose a different disk drive or solid-state drive placement that depends on your data protection strategy.

3. Record the position (an available empty slot) where the new disk drive must be installed. For example, the next available disk drive or SSD slot might be P4-D13.
4. Stop the system or logical partition. For instructions, see “Stopping a system or logical partition” on page 84.
5. Open the rack rear door.
6. Attach the electrostatic discharge (ESD) wrist strap.

Attention:

- Attach an electrostatic discharge (ESD) wrist strap to the front ESD jack, to the rear ESD jack, or to an unpainted metal surface of your hardware to prevent the electrostatic discharge from damaging your hardware.
 - When you use an ESD wrist strap, follow all electrical safety procedures. An ESD wrist strap is used for static control. It does not increase or decrease your risk of receiving electric shock when using or working on electrical equipment.
 - If you do not have an ESD wrist strap, just prior to removing the product from ESD packaging and installing or replacing hardware, touch an unpainted metal surface of the system for a minimum of 5 seconds.
7. Disconnect the power source from the system by unplugging the system. For instructions, see “Disconnecting the power cords from the system” on page 92.

Note: The system might be equipped with redundant power supply. Before you continue with this procedure, ensure that all power to your system is disconnected.

(L003)

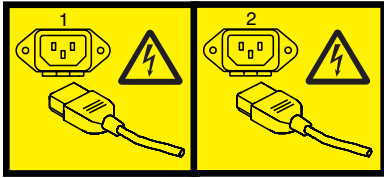

OR



OR



OR

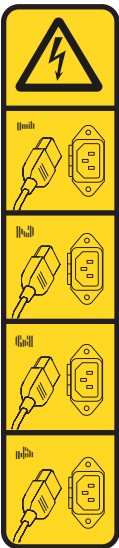

OR

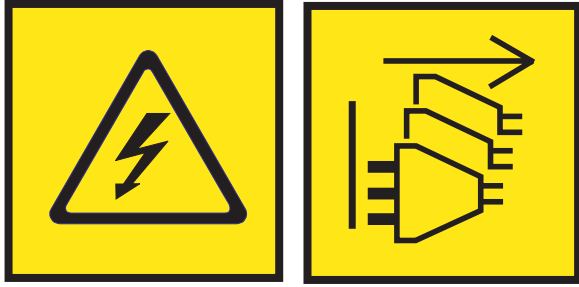

DANGER: Multiple power cords. The product might be equipped with multiple AC power cords or multiple DC power cables. To remove all hazardous voltages, disconnect all power cords and power cables. (L003)

8. Find the package that contains the new drive.

Attention: Drives are fragile. Handle with care.

9. Remove the drive from the static-protective package and place it on an ESD mat.

Installing a solid-state drive in the 8408-44E or 8408-E8E system with the power turned off

To install a solid-state drive (SSD) in the system, complete the steps in this procedure.

Procedure

1. Ensure that you have the electrostatic discharge (ESD) wrist strap attached. If not, attach it now.
2. Remove the front cover. For instructions, see “Removing the front cover from an 8408-44E or 8408-E8E system” on page 98.

(L007)



CAUTION: A hot surface nearby. (L007)

3. With the SSD drive bay handle (A) in the unlocked position, pull the lever outward to gain access to the guide rails in the SSD slot. Support the bottom of the SSD as you align it with the guide rails in the SSD slot. See Figure 5 on page 11.

Note: Support the drive by holding the drive by its sides.

4. Slide the SSD into the system until the drive stops, and then lock the SSD by rotating the bay handle (A) in the direction shown. See Figure 5 on page 11.

Important: When you install an SSD, ensure that the SSD is fully seated and is all the way into the system.

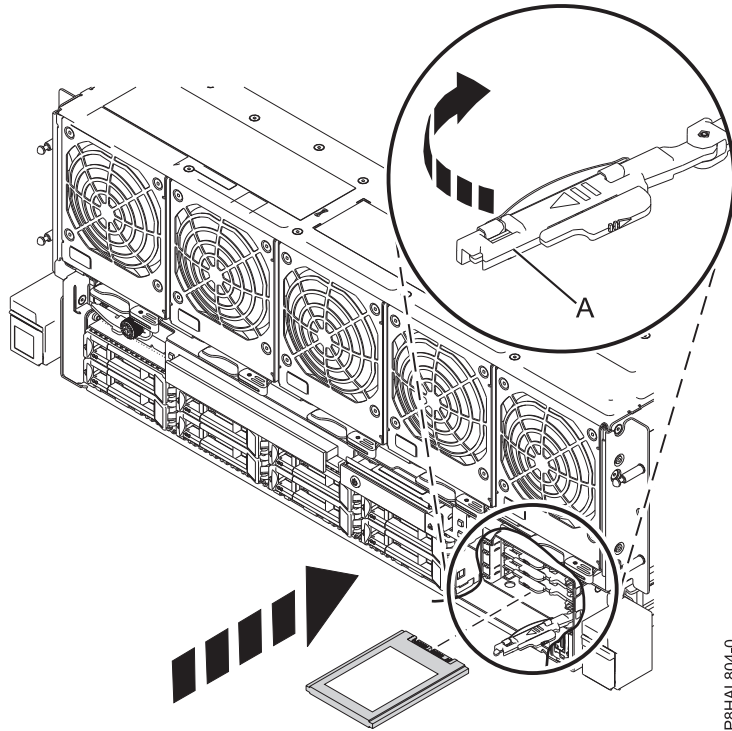

Figure 5. Installing an SSD in an 8408-44E or 8408-E8E system

5. If you are installing more than one drive, repeat the steps in this procedure until all drives are installed.

Preparing the 8408-44E or 8408-E8E system for operation after installing a solid-state drive with the power turned off

Learn to prepare the system for operation after you install a solid-state drive (SSD) in the system, with the system power turned off.

To prepare the system for operation, complete the following steps:

1. Ensure that you have the electrostatic discharge (ESD) wrist strap attached. If not, attach it now.
2. Reconnect the power cords to the system. For instructions, see “Connecting the power cords to the system” on page 95.
3. If applicable, replace the front cover. For instructions, see “Installing the front cover on an 8408-44E or 8408-E8E system” on page 98.
4. Start the system or logical partition. For instructions, see “Starting the system or logical partition” on page 86.
5. On the front of the system, verify that the power LED is **ON** (green) for the installed or replaced drive.
6. To configure the newly installed disk drive or solid-state drive, see the following procedures for the applicable operating system that controls the disk drive or solid-state drive:
 - “Configuring a disk drive or solid-state drive for use in an AIX system or AIX logical partition” on page 64.
 - “Configuring a disk drive or solid-state drive for use in an Linux system or Linux logical partition” on page 67.

Installing a disk drive or SSD in the 8408-44E or 8408-E8E system with the power turned on

Learn how to install a disk drive or solid-state drive (SSD) in a system with the system power turned on.

Installing a disk drive or solid-state drive in the 8408-44E or 8408-E8E system with the power turned on in AIX

Learn how to install a disk drive or solid-state drive (SSD) in a system with the AIX® operating system or AIX logical partition that controls the drive location powered on.

Before you install a feature, ensure that the software that is required to support the feature is installed on your system. For information about software prerequisites, see the IBM Prerequisite website (http://www-912.ibm.com/e_dir/eServerPrereq.nsf). If the required software is not installed, see the following websites to download it, and then install it before you continue:

- To download system firmware updates, software updates, and fix packs, see the Fix Central website (<http://www.ibm.com/support/fixcentral/>).
- To download Hardware Management Console (HMC) updates and fixes, see the Hardware Management Console Support and downloads website (www14.software.ibm.com/webapp/set2/sas/f/hmcl/home.html).

To install a disk drive or solid-state drive in a system, complete the following steps:

1. “Preparing the 8408-44E or 8408-E8E system to install a disk drive or solid-state drive with the power turned on in AIX.”
2. “Installing a disk drive or SSD in the 8408-44E or 8408-E8E system with the power turned on in AIX” on page 14.
3. “Preparing the 8408-44E or 8408-E8E system for operation after installing a disk drive or solid-state drive with the power turned on in AIX” on page 17.

Note: Installing this feature is a customer task. You can complete this task yourself, or contact a service provider to complete the task for you. You might be charged a fee by the service provider for this service.

Preparing the 8408-44E or 8408-E8E system to install a disk drive or solid-state drive with the power turned on in AIX:

To install a disk drive or solid-state drive (SSD) in the system with the AIX operating system powered on, complete the steps in this procedure.

If you are installing SSDs, review the configuration rules and then return here. For details, see “Solid-state drive configuration rules” on page 55.

Procedure

1. Ensure that the software that is required to support the feature is installed on your system. For information about software prerequisites, see the IBM Prerequisite website (http://www-912.ibm.com/e_dir/eServerPrereq.nsf). If the required system firmware, software, or fix packs are not installed on your system, go to the Fix Central website (<http://www.ibm.com/support/fixcentral/>) to download and install them before you continue.
2. Determine the slot in which you want to install a disk drive or an SSD. The disk drive and SSD slots are in the front of a system.

Figure 6 on page 13 shows the disk drive and solid-state drive locations and service indicators. Service indicators are located above the latch handle on the disk drives.

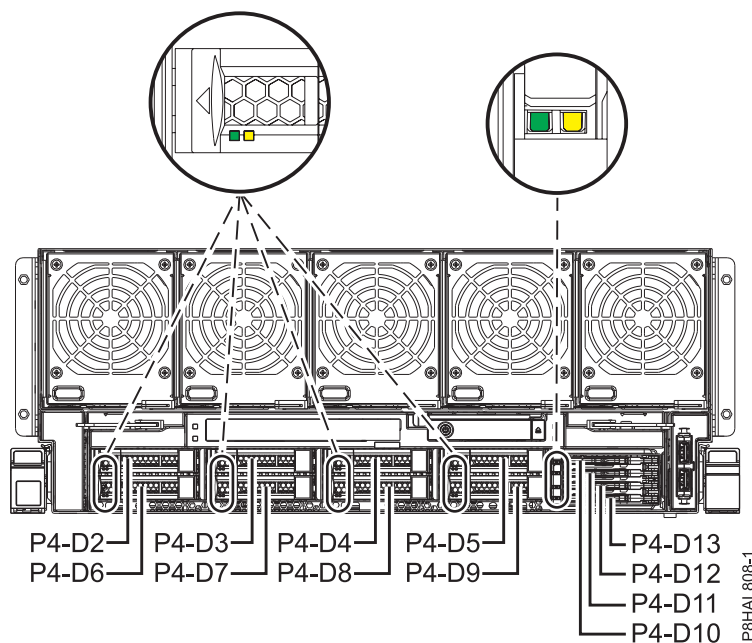

Figure 6. Disk drive and solid-state drive locations and service indicators for the system

Note: When you have drive slots available in a system, enclosure, or expansion unit, fill the slot positions in the system first. However, you can choose a different disk drive or solid-state drive placement that depends on your data protection strategy.

3. To identify the available slot by using the diagnostic command, complete the following steps:
 - a. Log in as root user.
 - b. At the command line, type `diag` and then press Enter.
 - c. On the Diagnostic Operating Instructions display, press Enter to continue.
 - d. On the Function Selection display, select **Task Selection**.
 - e. Select **RAID Array Manager**.
 - f. Select **IBM SAS Disk Array Manager**.
 - g. Select **Diagnostics and Recovery Options**.
 - h. Select **SCSI and SCSI RAID Hot Plug Manager**.
 - i. Select **Attach a Device to a SCSI Hot Swap Enclosure Device**. A list of empty slots in the SCSI hot swap enclosure device is shown.
4. Record the position (an available empty slot) where the new disk drive must be installed. For example, the next available disk drive or SSD slot might be P2-D3.
5. Find the package that contains the new drive.

Attention: Drives are fragile. Handle with care.
6. Attach the electrostatic discharge (ESD) wrist strap.

Attention:

- Attach an electrostatic discharge (ESD) wrist strap to the front ESD jack, to the rear ESD jack, or to an unpainted metal surface of your hardware to prevent the electrostatic discharge from damaging your hardware.
 - When you use an ESD wrist strap, follow all electrical safety procedures. An ESD wrist strap is used for static control. It does not increase or decrease your risk of receiving electric shock when using or working on electrical equipment.
 - If you do not have an ESD wrist strap, just prior to removing the product from ESD packaging and installing or replacing hardware, touch an unpainted metal surface of the system for a minimum of 5 seconds.
7. Remove the drive from the static-protective package and place it on an ESD mat.

Installing a disk drive or SSD in the 8408-44E or 8408-E8E system with the power turned on in AIX:

To install a disk drive or solid-state drive (SSD) in a system with the AIX operating system or AIX logical partition that controls the drive location powered on, complete the steps in this procedure.

Procedure

1. Ensure that you have the electrostatic discharge (ESD) wrist strap attached. If not, attach it now.
2. Choose from the following options:
 - If you are installing a disk drive or SSD in locations Un-P4-D2 through Un-P4-D9 in a 8408-44E or 8408-E8E system, continue with step 3.
 - If you are installing a 1.8-inch SSD in locations Un-P4-D10 through Un-P4-D13 in a 8408-44E or 8408-E8E system, continue with step 12 on page 16.
3. If the slot you want to use contains a drive filler, remove the drive filler from the slot.
To remove a filler from an 8408-44E or 8408-E8E system, complete the following steps:
 - a. Push the lock (A) on the handle of the filler in the direction that is shown in Figure 7 on page 15.
 - b. Hold the handle and pull out the filler from the slot.

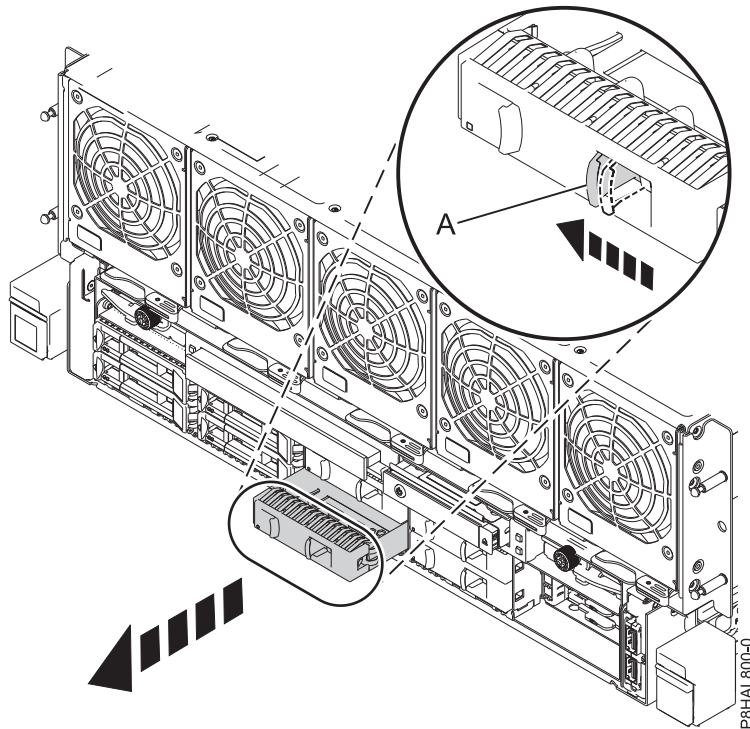

Figure 7. Removing a disk drive filler from an 8408-44E or 8408-E8E system

4. Unlock the drive bay handle (A) by pressing it and pulling it out toward you. If the handle is not all the way out, the drive does not slide into the system. See Figure 8 on page 16.
5. Hold the drive by the top and bottom edges as you position the drive, and insert it into the drive slot.
6. Slide the drive halfway into the system.
7. On the console, select the drive that you want to install and then press Enter.
8. When the identify LED turns on solid, slide the drive all the way into the system, and push the drive carrier handle (A) in until it locks, as shown in the following figure. Figure 8 on page 16.

Important: Ensure that the drive is fully seated and is all the way into the system.

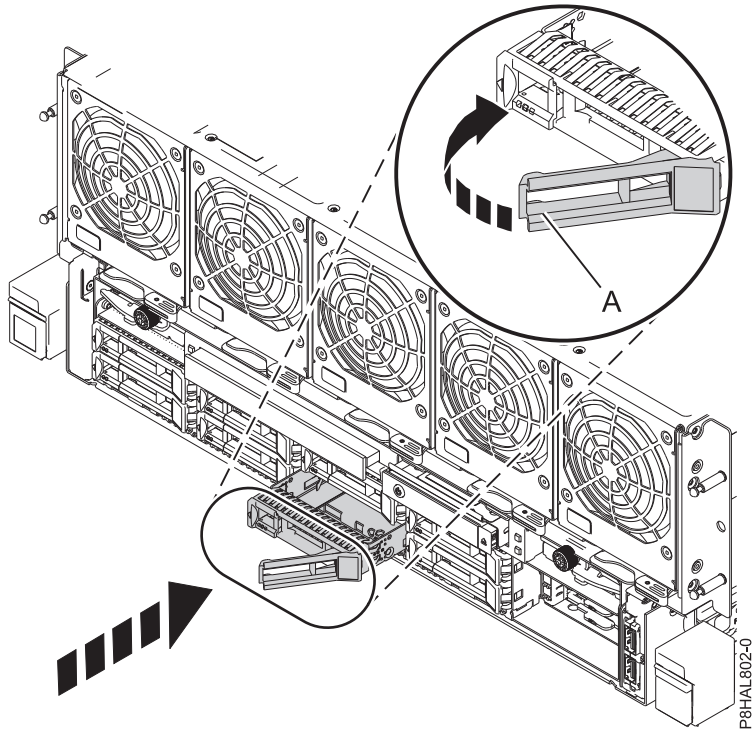

Figure 8. Installing a disk drive in a system

9. On the console, press Enter to indicate that you installed the drive.
10. If you are installing more than one drive, repeat the steps in this procedure until all drives are installed.
11. Proceed to the procedure for preparing the system for operation. For instructions, go to “Preparing the 8408-44E or 8408-E8E system for operation after installing a disk drive or solid-state drive with the power turned on in AIX” on page 17.
12. To install a 1.8-inch SSD in locations Un-P4-D10 through Un-P4-D13 in the 8408-44E or 8408-E8E, continue with the next step.
13. Remove the front cover. For instructions, see “Removing the front cover from an 8408-44E or 8408-E8E system” on page 98.

(L007)



CAUTION: A hot surface nearby. (L007)

14. With the SSD drive bay handle (A) in the unlocked position, pull the lever outward to gain access to the guide rails in the SSD slot. Support the bottom of the SSD as you align it with the guide rails in the SSD slot. See Figure 9 on page 17.

Note: Support the drive by holding the drive by its sides.

15. Slide the drive halfway into the system.
 16. On the console, select the drive that you want to install and then press Enter.
- 16** Disk drives or solid-state drives

17. When the identify LED turns on solid, slide the drive all the way into the system until the drive stops.
18. Lock the drive by rotating the bay handle (A) in the direction that is shown in Figure 9.

Important: When you install an SSD, ensure that the SSD is fully seated and is all the way into the system.

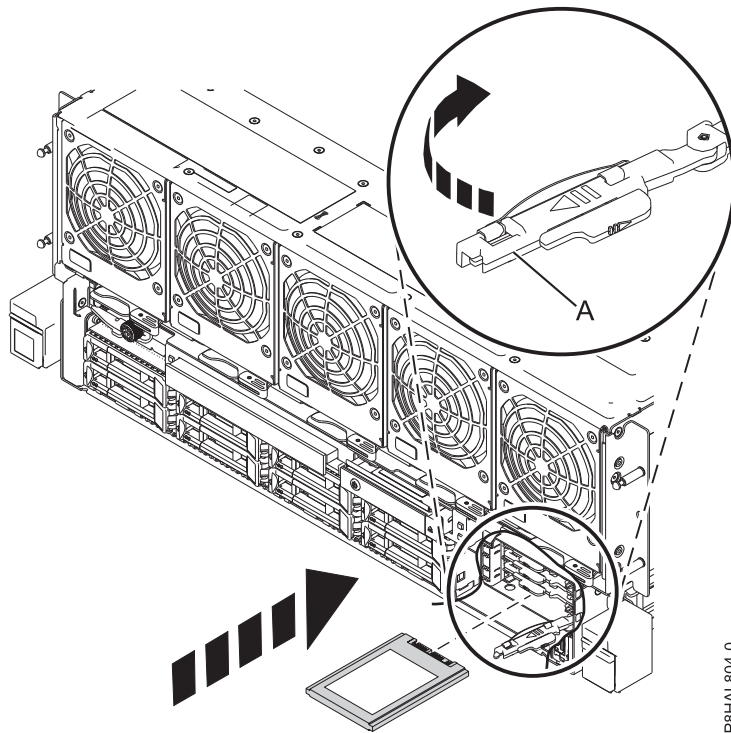

Figure 9. Installing an SSD in an 8408-44E or 8408-E8E system

19. On the console, press Enter to indicate that you installed the drive.
20. If you are installing more than one drive, repeat the steps in this procedure until all drives are installed.

Preparing the 8408-44E or 8408-E8E system for operation after installing a disk drive or solid-state drive with the power turned on in AIX:

Learn to prepare the system for operation after you install a disk drive or solid-state drive (SSD) in the system with the AIX operating system or AIX logical partition that controls the drive location powered on.

To prepare the system for operation, complete the following steps:

1. Ensure that you have the electrostatic discharge (ESD) wrist strap attached. If not, attach it now.
2. If applicable, replace the front cover. For instructions, see “Installing the front cover on an 8408-44E or 8408-E8E system” on page 98.
3. On the front of the system, verify that the power LED is **ON** (green) for the installed or replaced drive.
4. To configure the newly installed disk drive or solid-state drive, see “Configuring a disk drive or solid-state drive for use in an AIX system or AIX logical partition” on page 64.

Installing a disk drive or SSD in the 8408-44E or 8408-E8E system with the power turned on in Linux

Learn how to install a disk drive or solid-state drive (SSD) in a Linux system or a Linux logical partition with the power turned on.

Before you install a feature, ensure that the software that is required to support the feature is installed on your system. For information about software prerequisites, see the IBM Prerequisite website (http://www-912.ibm.com/e_dir/eServerPrereq.nsf). If the required software is not installed, see the following websites to download it, and then install it before you continue:

- To download system firmware updates, software updates, and fix packs, see the Fix Central website (<http://www.ibm.com/support/fixcentral/>).
- To download Hardware Management Console (HMC) updates and fixes, see the Hardware Management Console Support and downloads website (www14.software.ibm.com/webapp/set2/sas/f/hmcl/home.html).

To install a disk drive or solid-state drive in a system, complete the following steps:

1. “Preparing the 8408-44E or 8408-E8E system to install a disk drive or SSD with the power turned on in Linux.”
2. “Installing a disk drive or SSD in the 8408-44E or 8408-E8E system with the power turned on in Linux” on page 20.
3. “Preparing the 8408-44E or 8408-E8E system for operation after installing a disk drive or SSD with the power turned on in Linux” on page 23.

Note: Installing this feature is a customer task. You can complete this task yourself, or contact a service provider to complete the task for you. You might be charged a fee by the service provider for this service.

Preparing the 8408-44E or 8408-E8E system to install a disk drive or SSD with the power turned on in Linux:

Learn about the steps you must complete before you install a disk drive or solid-state drive (SSD) in a system with the Linux operating system or Linux logical partition that controls the drive location powered on.

If you are installing SSDs, review the configuration rules and then return here. For details, see “Solid-state drive configuration rules” on page 55.

To prepare the system to install a disk drive or solid-state drive, complete the following steps:

1. Ensure that the software that is required to support the feature is installed on your system. For information about software prerequisites, see the IBM Prerequisite website (http://www-912.ibm.com/e_dir/eServerPrereq.nsf). If the required system firmware, software, or fix packs are not installed on your system, go to the Fix Central website (<http://www.ibm.com/support/fixcentral/>) to download and install them before you continue.
2. Determine the slot in which you want to install a disk drive or an SSD. The disk drive and SSD slots are in the front of a system.

Figure 10 on page 19 shows the disk drive and solid-state drive locations and service indicators. Service indicators are located above the latch handle on the disk drives.

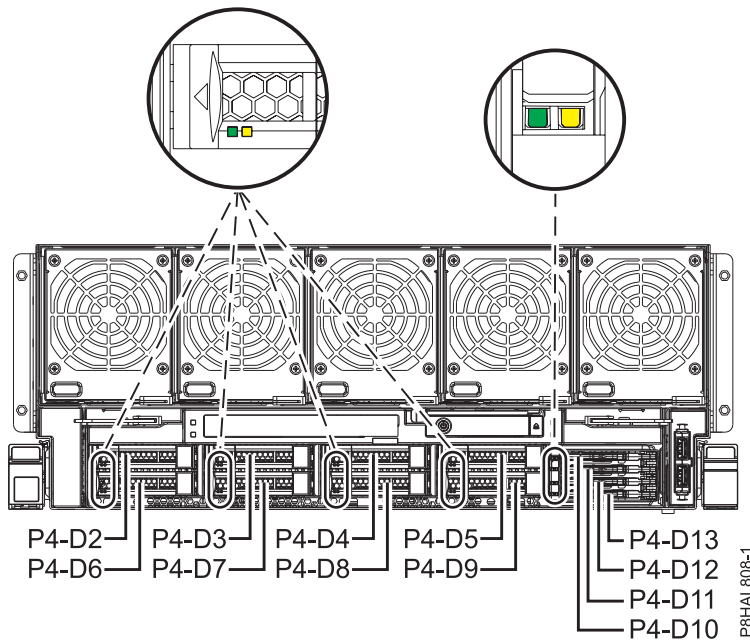

Figure 10. Disk drive and solid-state drive locations and service indicators for the system

Note: When you have drive slots available in a system, enclosure, or expansion unit, fill the slot positions in the system first. However, you can choose a different disk drive or solid-state drive placement that depends on your data protection strategy.

3. To identify the available slot by using the **iprconfig** command, complete the following steps:
 - a. Log in as root user.
 - b. Type **iprconfig** on the command line of the Linux session, and then press Enter. The IBM Power RAID Configuration Utility display is shown.
 - c. Select **Work with disk unit recovery** from the IBM Power RAID Configuration Utility display, and then press Enter.
 - d. Select **Concurrent add device** from the Work with Disk Unit Recovery display, and then press Enter.

A Concurrent Device Add display, similar to Figure 11, is shown.

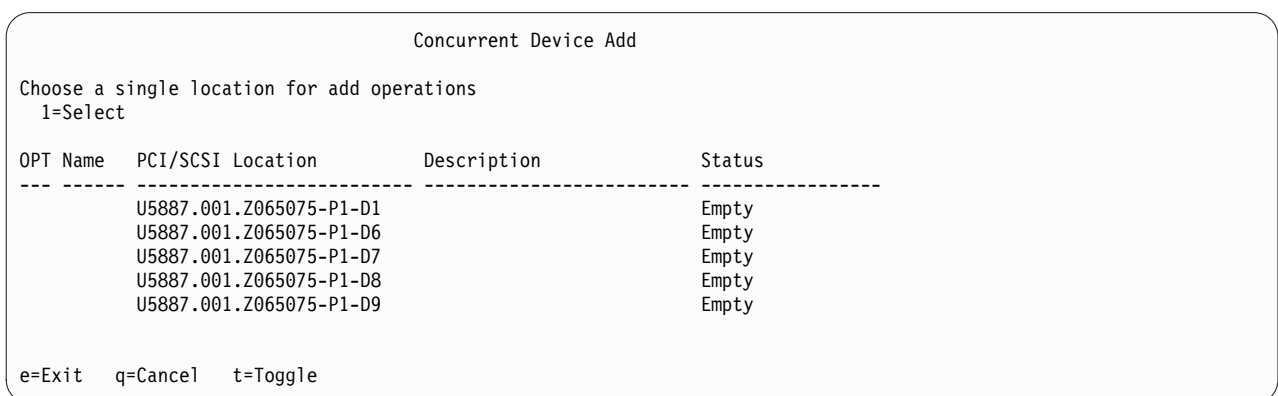

Figure 11. Example Concurrent Device Add display

- e. Type **t** if you want to toggle through different location code representations.

- f. Type 1 next to the location into which you want to install the disk drive or solid-state drive and press Enter. The **Verify Device Concurrent Add** display is shown and the service indicator flashes for the selected slot.
- g. Do not press Enter again. Follow the rest of the procedure to complete installing the drive.
4. Record the position (an available empty slot) where the new disk drive must be installed. For example, the next available disk drive or SSD slot might be P2-D3.
5. Find the package that contains the new drive.
Attention: Drives are fragile. Handle with care.
6. Attach the electrostatic discharge (ESD) wrist strap.
Attention:
 - Attach an electrostatic discharge (ESD) wrist strap to the front ESD jack, to the rear ESD jack, or to an unpainted metal surface of your hardware to prevent the electrostatic discharge from damaging your hardware.
 - When you use an ESD wrist strap, follow all electrical safety procedures. An ESD wrist strap is used for static control. It does not increase or decrease your risk of receiving electric shock when using or working on electrical equipment.
 - If you do not have an ESD wrist strap, just prior to removing the product from ESD packaging and installing or replacing hardware, touch an unpainted metal surface of the system for a minimum of 5 seconds.
7. Remove the drive from the static-protective package and place it on an ESD mat.

Installing a disk drive or SSD in the 8408-44E or 8408-E8E system with the power turned on in Linux:

To install a disk drive or solid-state drive (SSD) in a system with the Linux operating system on, complete the steps in this procedure.

Procedure

1. Ensure that you have the electrostatic discharge (ESD) wrist strap attached. If not, attach it now.
2. Choose from the following options:
 - If you are installing a disk drive or SSD in locations Un-P4-D2 through Un-P4-D9 in a 8408-44E or 8408-E8E system, continue with step 3.
 - If you are installing an 1.8-inch SSD in locations Un-P4-D10 through Un-P4-D13 in a 8408-44E or 8408-E8E system, continue with step 12 on page 22.
3. If the slot you want to use contains a drive filler, remove the drive filler from the slot.
To remove a filler from an 8408-44E or 8408-E8E system, complete the following steps:
 - a. Push the lock (A) on the handle of the filler in the direction that is shown in Figure 12 on page 21.
 - b. Hold the handle and pull out the filler from the slot.

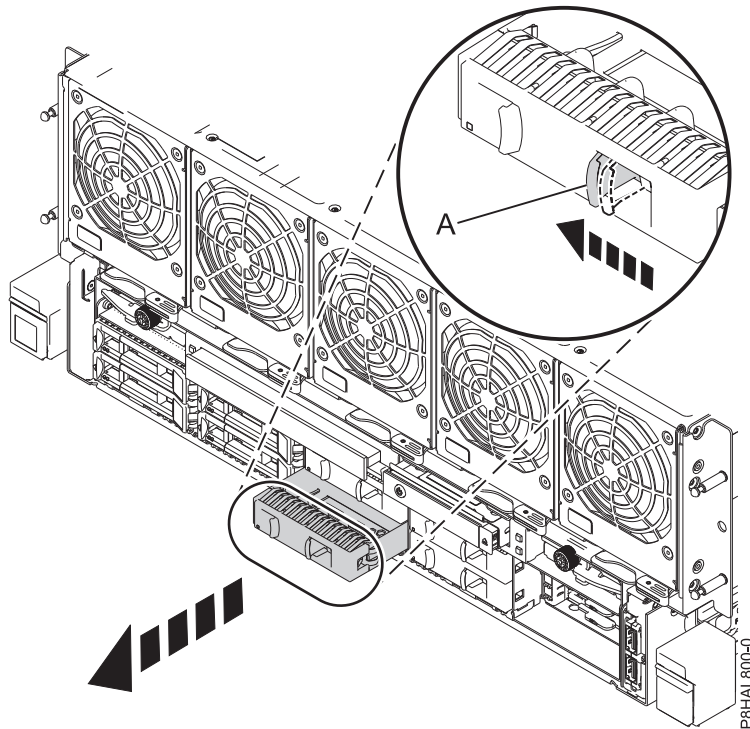

Figure 12. Removing a disk drive filler from an 8408-44E or 8408-E8E system

4. Unlock the drive bay handle (A) by pressing it and pulling it out toward you. If the handle is not all the way out, the drive does not slide into the system. See Figure 13 on page 22.
5. Hold the drive by the top and bottom edges as you position the drive, and insert it into the drive slot.
6. Slide the drive halfway into the system.
7. Return to the console, and then press Enter. In the Verify Device Concurrent Add display, verify that the selected slot is the slot in which you want to install the drive.
8. When the identify LED flashes for the selected slot, slide the drive all the way into the slot, and push the drive bay handle (A) in until it locks, as shown in Figure 13 on page 22.

Important: Ensure that the drive is fully seated and is all the way into the system.

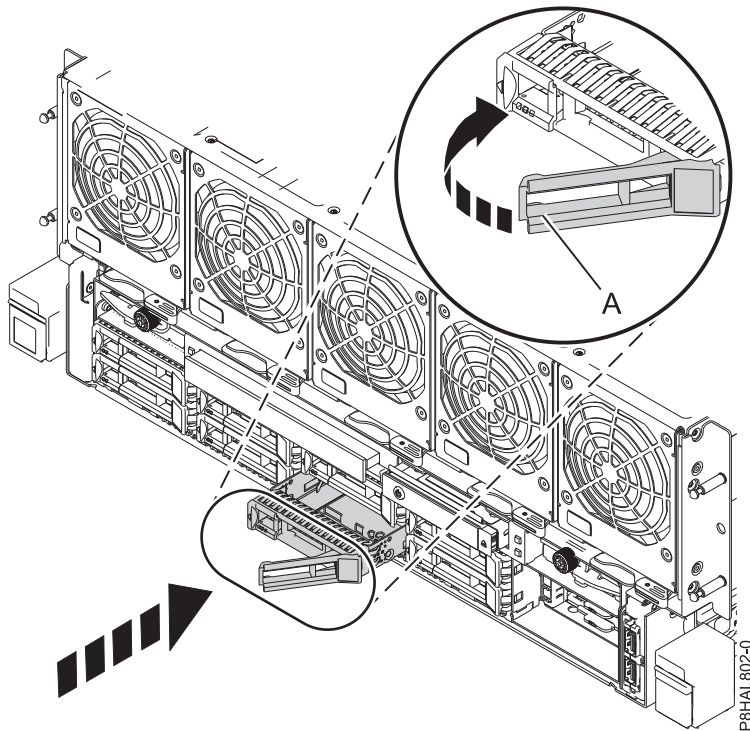

Figure 13. Installing a disk drive in an 8408-44E or 8408-E8E system

9. On the console, press Enter to indicate that you installed the drive.
10. If you are installing more than one drive, repeat the steps in this procedure until all drives are installed.
11. Proceed to the procedure for preparing the system for operation. For instructions, go to “Preparing the 8408-44E or 8408-E8E system for operation after installing a disk drive or SSD with the power turned on in Linux” on page 23.
12. To install an 1.8-inch SSD in locations Un-P4-D10 through Un-P4-D13 in the 8408-44E or 8408-E8E, continue with the next step.
13. Remove the front cover. For instructions, see “Removing the front cover from an 8408-44E or 8408-E8E system” on page 98.

(L007)



CAUTION: A hot surface nearby. (L007)

14. With the SSD drive bay handle (A) in the unlocked position, pull the lever outward to gain access to the guide rails in the SSD slot. Support the bottom of the SSD as you align it with the guide rails in the SSD slot. See Figure 14 on page 23.

Note: Support the drive by holding the drive by its sides.

15. Slide the drive halfway into the system.
16. On the console, select the drive that you want to install and then press Enter.

17. When the identify LED turns on solid, slide the drive all the way into the system until the drive stops.
18. Lock the drive by rotating the bay handle (A) in the direction that is shown in Figure 14.

Important: When you install an SSD, ensure that the SSD is fully seated and is all the way into the system.

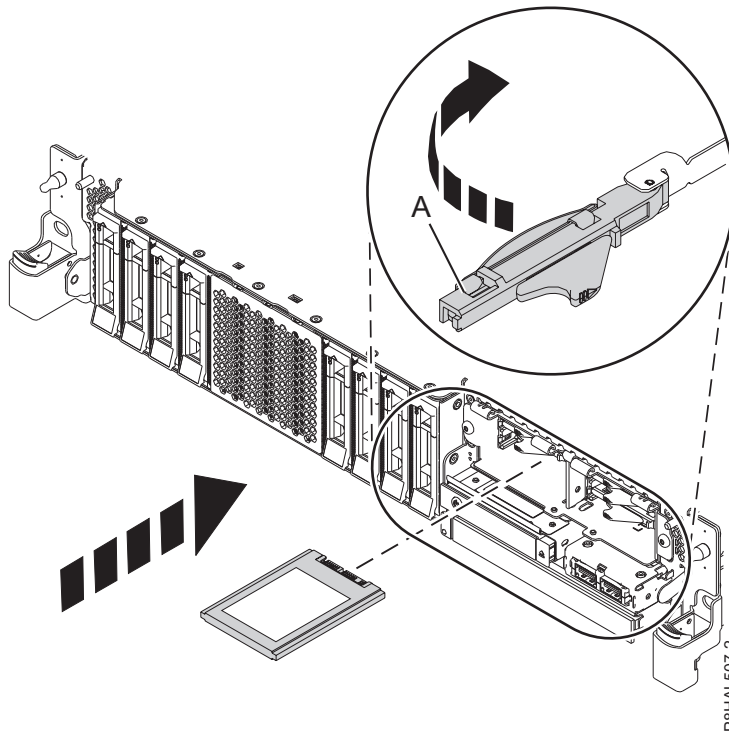

Figure 14. Installing an SSD in an 8408-44E or 8408-E8E system

19. On the console, press Enter to indicate that you installed the drive.
20. If you are installing more than one drive, repeat the steps in this procedure until all drives are installed.

Preparing the 8408-44E or 8408-E8E system for operation after installing a disk drive or SSD with the power turned on in Linux:

Learn to prepare the system for operation after you install a disk drive or solid-state drive (SSD) in the system with the Linux operating system or Linux logical partition that controls the drive location powered on.

To prepare the system for operation, complete the following steps:

1. Press Enter on the Complete Device Concurrent Add display to indicate that the disk drive or solid-state drive is installed. The service indicator stops flashing and turns off for that drive slot.
2. To verify that the new disk drive or solid-state drive is operational, complete the following steps:
 - a. Log in as root user.
 - b. Type `iprconfig` on the command line of the Linux session and press Enter. The IBM Power RAID Configuration Utility display is shown.
 - c. Select **Display hardware status**. The Display Hardware Status display is shown, similar to the following figure.

```

Display Hardware Status

Type option, press Enter.
  l=Display hardware resource information details

OPT Name      PCI/SCSI Location      Description      Status
-----
0000:01:00.0/0:  PCI-E SAS RAID Adapter  Operational
0000:01:00.0/0:0:0:0  Advanced Function SSD    Active
0000:01:00.0/0:0:1:0  Advanced Function SSD    Active
0000:01:00.0/0:0:2:0  Advanced Function SSD    Active
0000:01:00.0/0:0:3:0  Advanced Function SSD    Active
0000:01:00.0/0:0:4:0  Advanced Function SSD    Active
0000:01:00.0/0:0:5:0  Advanced Function SSD    Active
0000:01:00.0/0:0:6:0  Advanced Function SSD    Active
0000:01:00.0/0:0:8:0  Enclosure                 Active
0000:01:00.0/0:0:9:0  Enclosure                 Active
0001:01:00.0/1:  PCI-E SAS RAID Adapter  Operational
0001:01:00.0/1:0:3:0  Advanced Function SSD    Remote
0001:01:00.0/1:0:4:0  Advanced Function SSD    Remote
0001:01:00.0/1:0:5:0  Advanced Function SSD    Remote
More...

e=Exit  q=Cancel  r=Refresh  t=Toggle  f=PageDn  b=PageUp

```

Figure 15. Example Display Hardware Status

- d. Verify that the disk drive or solid-state drive that you installed is shown on this display.
3. Ensure that you have the electrostatic discharge (ESD) wrist strap attached. If not, attach it now.
4. On the front of the system, verify that the power LED is ON (green) for the installed or replaced drive.
5. If applicable, replace the front cover. For instructions, see “Installing the front cover on an 8408-44E or 8408-E8E system” on page 98.
6. To configure the newly installed disk drive or solid-state drive, see “Configuring a disk drive or solid-state drive for use in an Linux system or Linux logical partition” on page 67.

Removing and replacing a disk drive or solid-state drive in the 8408-44E or 8408-E8E

Find information about removing and replacing a serial-attached SCSI (SAS) disk drive or a solid-state drive (SSD) in a system.

If you are removing and replacing a disk drive or solid-state drive in a 5887 disk drive enclosure or 5147-024, ESLL, or ESLS storage enclosure, see Removing and replacing a disk drive or solid-state drive in the 5887 disk drive enclosure(http://www.ibm.com/support/knowledgecenter/POWER8/p8hal/p8hal_5887_rnr_kickoff.htm) or Removing and replacing a disk drive or solid-state drive in the 5147-024, ESLL, or ESLS storage enclosure storage enclosure(http://www.ibm.com/support/knowledgecenter/POWER8/p8hal/p8hal_eslx_rnr_kickoff.htm).

Removing and replacing a disk drive or solid-state drive in the 8408-44E or 8408-E8E with the system power turned off

Learn how to remove and replace a disk drive or solid-state drive (SSD) in a system with the system power turned off.

To remove and replace a disk drive or solid-state drive in a system, complete the following steps:

1. “Preparing the 8408-44E or 8408-E8E system to remove and replace a disk drive or solid-state drive with the power turned off” on page 25.
2. “Removing a disk drive or SSD from the 8408-44E or 8408-E8E system” on page 27.

3. "Replacing a disk drive or SSD in the 8408-44E or 8408-E8E system" on page 29.
4. "Preparing the 8408-44E or 8408-E8E system for operation after removing and replacing a disk drive or SSD with the power turned off" on page 31.

Note: Removing or replacing this feature is a customer task. You can complete this task yourself, or contact a service provider to complete the task for you. You might be charged a fee by the service provider for this service.

Preparing the 8408-44E or 8408-E8E system to remove and replace a disk drive or solid-state drive with the power turned off

Learn about the steps you must complete before you remove and replace a disk drive or solid-state drive (SSD) in the system with the system power turned off.

To prepare the system to remove and replace a disk drive or solid-state drive, complete the following steps:

1. Prepare to remove the disk drive or solid-state drive from the system, drive enclosure, or expansion unit by using one of the following procedures depending on the operating system that controls the drive location:
 - If the system or logical partition that controls the disk drive or solid-state drive location is running the AIX operating system, see "Preparing the system to remove a disk drive or solid-state drive in AIX" on page 63.
 - If the system or logical partition that controls the disk drive or solid-state drive location is running the Linux operating system, see "Preparing the system to remove a disk drive or solid-state drive in Linux" on page 64
2. If you are removing a solid-state device that is on a PCIe RAID and SSD SAS adapter, go to Replacing an SSD module on the PCIe RAID and SSD SAS adapter and complete that procedure.
3. Identify the part and the system that you want to service. The disk drive and SSD slots are in the front of a system.

Figure 16 shows the disk drive and solid-state drive locations and service indicators. Service indicators are located above the latch handle on the disk drives.

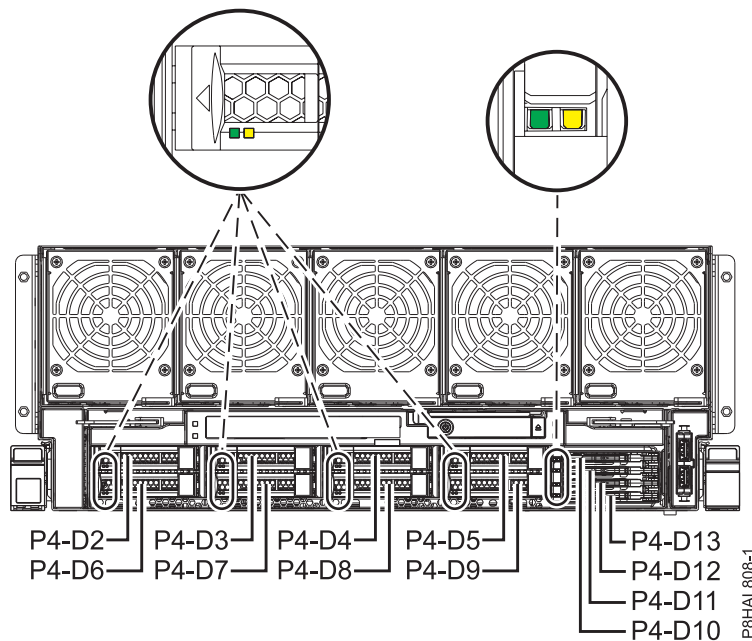

Figure 16. Disk drive and service indicator locations for an 8408-44E or 8408-E8E system

4. Identify the disk drive or solid-state drive to be removed and record the location information. For instructions, see “Identifying a part” on page 76.
5. Stop the system or logical partition. For instructions, see “Stopping a system or logical partition” on page 84.
6. Open the rack rear door.
7. Attach the electrostatic discharge (ESD) wrist strap.

Attention:

- Attach an electrostatic discharge (ESD) wrist strap to the front ESD jack, to the rear ESD jack, or to an unpainted metal surface of your hardware to prevent the electrostatic discharge from damaging your hardware.
 - When you use an ESD wrist strap, follow all electrical safety procedures. An ESD wrist strap is used for static control. It does not increase or decrease your risk of receiving electric shock when using or working on electrical equipment.
 - If you do not have an ESD wrist strap, just prior to removing the product from ESD packaging and installing or replacing hardware, touch an unpainted metal surface of the system for a minimum of 5 seconds.
8. Disconnect the power source from the system by unplugging the system. For instructions, see “Disconnecting the power cords from the system” on page 92.

Note: The system might be equipped with redundant power supply. Before you continue with this procedure, ensure that all power to your system is disconnected.

(L003)

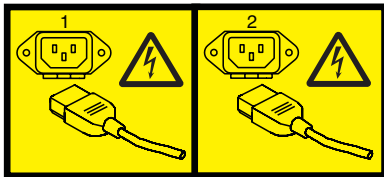

or

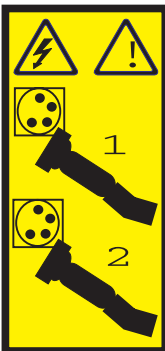

or



or

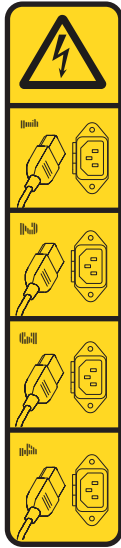

or

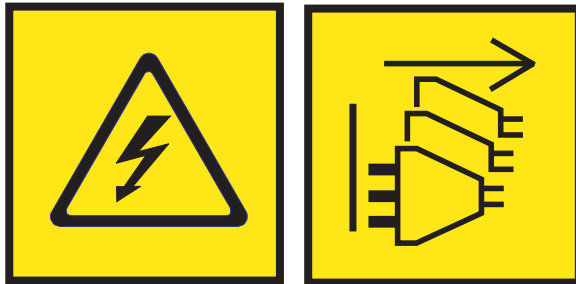

DANGER: Multiple power cords. The product might be equipped with multiple AC power cords or multiple DC power cables. To remove all hazardous voltages, disconnect all power cords and power cables. (L003)

9. Find the package that contains the new drive.

Attention: Drives are fragile. Handle with care.

10. Remove the drive from the static-protective package and place it on an ESD mat.

Removing a disk drive or SSD from the 8408-44E or 8408-E8E system

To remove a disk drive or solid-state drive (SSD) from a system, complete the steps in this procedure.

Procedure

1. Ensure that you have the electrostatic discharge (ESD) wrist strap attached. If not, attach it now.
2. Choose from the following options:
 - If you are removing a disk drive from a 8408-44E or 8408-E8E system, continue with step 3.
 - If you are removing an SSD from a 8408-44E or 8408-E8E system, continue with step 7 on page 28.
3. Unlock the drive handle (**B**) by pressing the handle latch (**A**) and pulling it out toward you, as shown in Figure 17 on page 28. If the handle is not all the way out, the solid-state drive cannot slide out of the system.

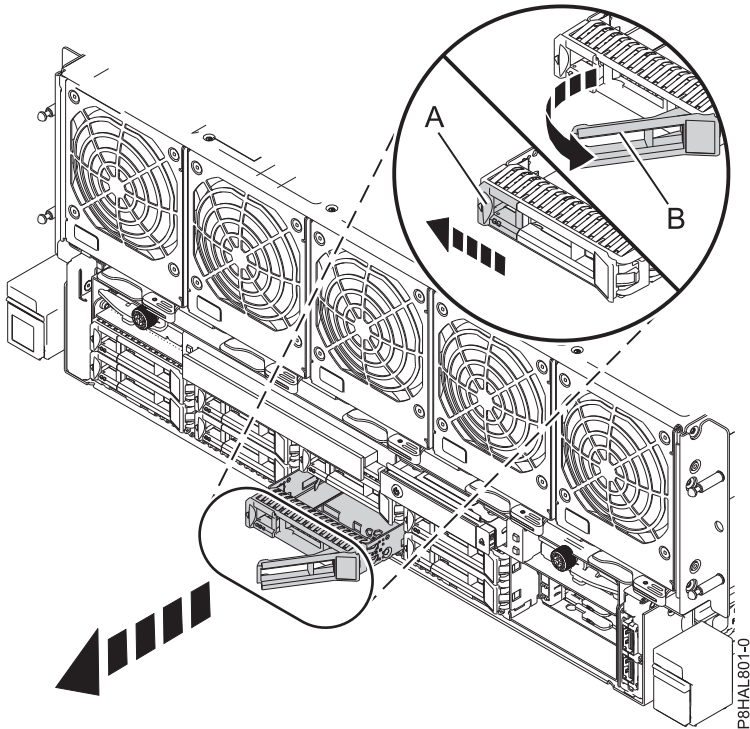

Figure 17. Removing a disk drive from the 8408-44E or 8408-E8E system

4. Support the bottom of the drive as you slide it out of the system. Hold the drive by its sides.
5. If you are removing more than one drive, repeat the steps in this procedure until all drives are removed.

Note: If you are not installing a replacement drive, install a filler in the empty slot to ensure proper air flow for cooling. For instructions, see “Installing a disk drive filler in the 8408-44E or 8408-E8E system” on page 50.

6. Proceed to the procedure for replacing the disk drive. For instructions, see “Replacing a disk drive or SSD in the 8408-44E or 8408-E8E system” on page 29.
7. To remove an SSD in the 8408-44E or 8408-E8E, continue with the next step.
8. Remove the front cover. For instructions, see “Removing the front cover from an 8408-44E or 8408-E8E system” on page 98.

(L007)



CAUTION: A hot surface nearby. (L007)

9. Unlock the drive handle (**B**) by pushing the handle latch (**A**) in the direction that is shown, and pulling the drive handle (**B**) out toward you, as shown in Figure 18 on page 29. If the handle is not all the way out, the solid-state drive cannot slide out of the system.

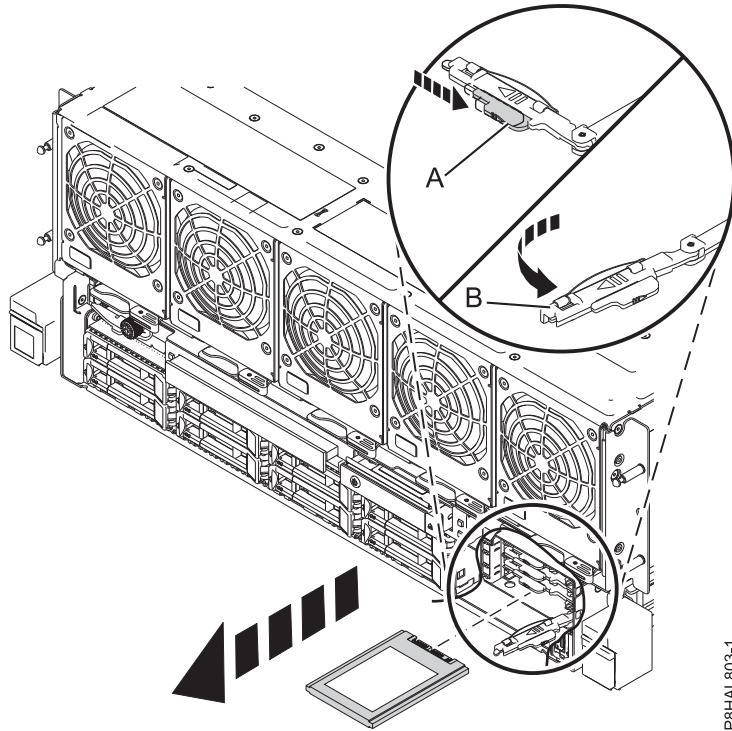

P8HAL803-1

Figure 18. Removing an SSD from an 8408-44E or 8408-E8E system

10. Support the bottom of the drive as you slide it out of the system. Hold the drive by its sides.
11. If you are not installing a replacement drive immediately, lock the drive bay handle (B) by rotating it inwards toward the system.
12. If you are removing more than one drive, repeat the steps in this procedure until all drives are removed.

Replacing a disk drive or SSD in the 8408-44E or 8408-E8E system

To replace a disk drive or solid-state drive (SSD) in a system, complete the steps in this procedure.

Procedure

1. Ensure that you have the electrostatic discharge (ESD) wrist strap attached. If not, attach it now.
2. Choose from the following options:
 - If you are replacing a disk drive in a 8408-44E or 8408-E8E system, continue with step 3.
 - If you are replacing an SSD from a 8408-44E or 8408-E8E system, continue with step 8 on page 30.
3. Unlock the drive bay handle (A) by pressing it and pulling it out toward you. If the handle is not all the way out, the drive does not slide into the system.
4. Hold the drive by the top and bottom edges as you position the drive, and insert it into the drive slot.
5. Slide the drive all the way into the system, and push the drive bay handle (A) in until it locks, as shown in Figure 19 on page 30.

Important: Ensure that the drive is fully seated and is all the way into the system.

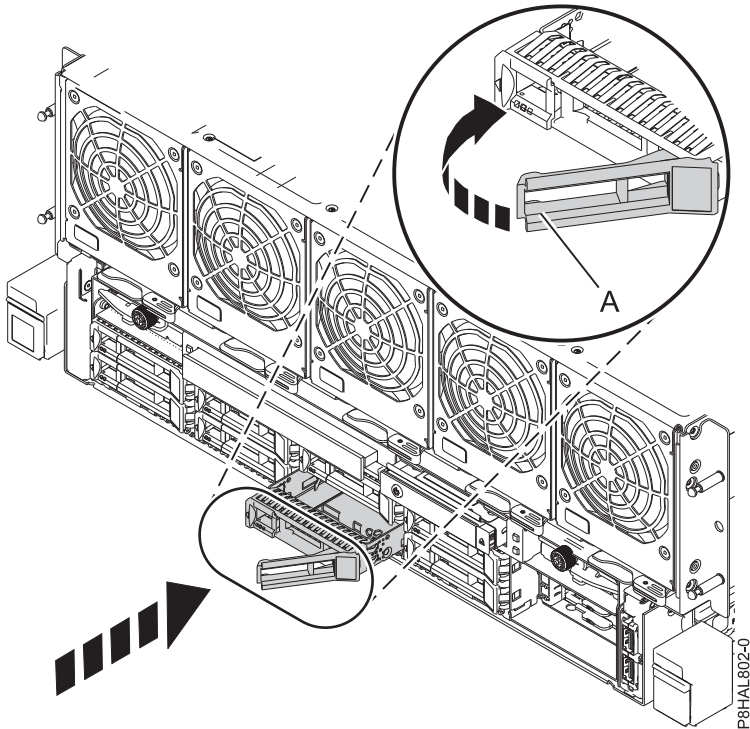

Figure 19. Replacing a disk drive in an 8408-44E or 8408-E8E system

6. If you are installing more than one drive, repeat the steps in this procedure until all drives are installed.
7. Proceed to the procedure for preparing the system for operation. For instructions, see Preparing the 8408-44E or 8408-E8E system for operation after removing and replacing a disk drive or SSD with the power turned off.
8. To replace an SSD in the 8408-44E or 8408-E8E, continue with the next step.
9. With the SSD drive bay handle (A) in the unlocked position, pull the lever outward to gain access to the guide rails in the SSD slot. Support the bottom of the SSD as you align it with the guide rails in the SSD slot. See Figure 20 on page 31.

Note: Support the drive by holding the drive by its sides.

10. Slide the SSD into the system until the drive stops, and then lock the SSD by rotating the handle (A) in the direction shown in Figure 20 on page 31.

Important: When you install an SSD, ensure that the SSD is fully seated and is all the way into the system.

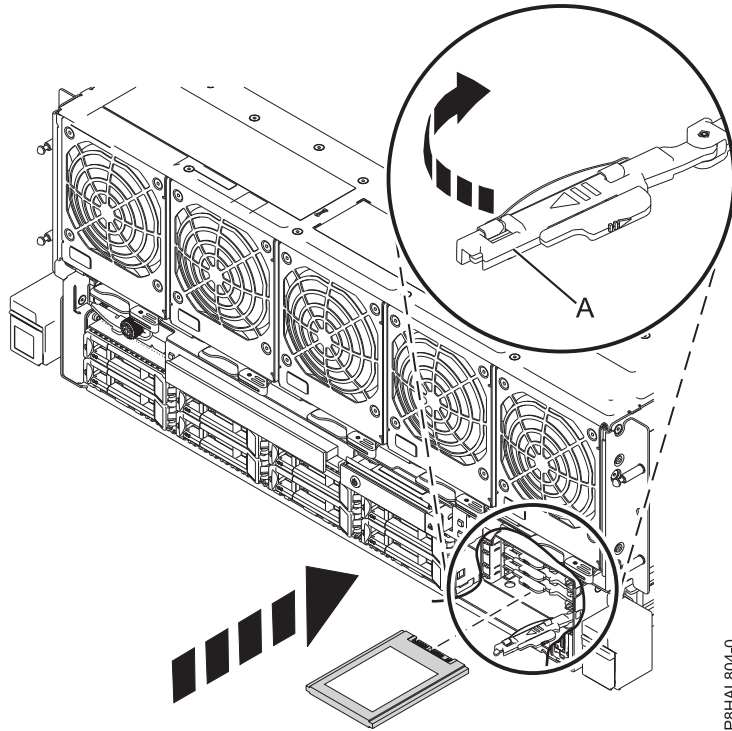

Figure 20. Replacing an SSD in an 8408-44E or 8408-E8E system

11. If you are installing more than one drive, repeat the steps in this procedure until all drives are installed.

Preparing the 8408-44E or 8408-E8E system for operation after removing and replacing a disk drive or SSD with the power turned off

Learn to prepare the system for operation after you replace a disk drive or solid-state drive (SSD) in the system with the system power turned off.

To prepare the system for operation, complete the following steps:

1. Ensure that you have the electrostatic discharge (ESD) wrist strap attached. If not, attach it now.
2. Reconnect the power cords to the system. For instructions, see “Connecting the power cords to the system” on page 95.
3. If applicable, replace the front cover. For instructions, see “Installing the front cover on an 8408-44E or 8408-E8E system” on page 98.
4. Start the system or logical partition. For instructions, see “Starting the system or logical partition” on page 86.
5. If you replaced a drive and have not verified the drive yet, verify that the power LED is **ON** (green) and the amber fault LED is **OFF** (not lit) for the replaced drive on the front of the system.
6. To configure the newly installed disk drive or solid-state drive, see the following procedures for the applicable operating system that controls the disk drive or solid-state drive:
 - “Configuring a disk drive or solid-state drive for use in an AIX system or AIX logical partition” on page 64.
 - “Configuring a disk drive or solid-state drive for use in a Linux system or Linux logical partition” on page 67.
7. To rebuild the data on the replacement disk drive or solid-state drive, or to recover from a failed or missing array, see the following procedures for the applicable operating system that controls the drive:

- “Rebuilding data on a replacement disk drive or solid-state drive in a system or logical partition running the AIX operating system” on page 68.
- “Rebuilding data on a replacement disk drive or solid-state drive in a system or logical partition that is running the Linux operating system” on page 69.

Removing and replacing a disk drive or SSD in the 8408-44E or 8408-E8E system with the power turned on in AIX

Learn how to remove and replace a disk drive or solid-state drive (SSD) in a system with the AIX operating system or an AIX logical partition that controls the drive location powered on.

To remove and replace a disk drive or solid-state drive in a system, complete the following steps:

1. “Preparing the 8408-44E or 8408-E8E system to remove and replace a disk drive or SSD with the power turned on in AIX.”
2. “Removing a disk drive or SSD from the 8408-44E or 8408-E8E system with the power turned on in AIX” on page 34.
3. “Replacing a disk drive or SSD in the 8408-44E or 8408-E8E system with the power turned on in AIX” on page 36.
4. “Preparing the 8408-44E or 8408-E8E system for operation after replacing a drive with the power turned on in AIX” on page 38.

Note: Removing or replacing this feature is a customer task. You can complete this task yourself, or contact a service provider to complete the task for you. You might be charged a fee by the service provider for this service.

Preparing the 8408-44E or 8408-E8E system to remove and replace a disk drive or SSD with the power turned on in AIX

Learn about the steps you must complete before you remove and replace a disk drive or solid-state drive (SSD) in a system with the AIX operating system or AIX logical partition that controls the drive location powered on.

If the drive that you are removing is in the root volume group (rootvg) and it is not protected by either Redundant Array of Independent Disks (RAID) or mirroring, or to use the powered-off procedure, go to “Removing and replacing a disk drive or solid-state drive in the 8408-44E or 8408-E8E with the system power turned off” on page 24.

To prepare the system to remove and replace a disk drive or solid-state drive, complete the following steps:

1. Before you remove a drive from a system that is controlled by the AIX operating system, ensure that all data on that drive or the array that contains the drive is backed up and removed from the drive. If the drive that is being replaced is protected by RAID or mirroring, it is not necessary to remove data. Ensure that the disks are in the defined state if the disks are just a bunch of disks (JBOD).
2. If you are removing a solid-state device that is on a PCIe RAID and SSD SAS adapter, go to Replacing an SSD module on the PCIe RAID and SSD SAS adapter and complete that procedure.
3. Find the package that contains the new drive.
Attention: Drives are fragile. Handle with care.
4. Attach the electrostatic discharge (ESD) wrist strap.

Attention:

- Attach an electrostatic discharge (ESD) wrist strap to the front ESD jack, to the rear ESD jack, or to an unpainted metal surface of your hardware to prevent the electrostatic discharge from damaging your hardware.
 - When you use an ESD wrist strap, follow all electrical safety procedures. An ESD wrist strap is used for static control. It does not increase or decrease your risk of receiving electric shock when using or working on electrical equipment.
 - If you do not have an ESD wrist strap, just prior to removing the product from ESD packaging and installing or replacing hardware, touch an unpainted metal surface of the system for a minimum of 5 seconds.
5. Remove the drive from the static-protective package and place it on an ESD mat.
 6. Identify the part and the system that you want to service. The disk drive and SSD slots are in the front of a system.

Figure 21 shows the disk drive and solid-state drive locations and service indicators. Service indicators are located above the latch handle on the disk drives.

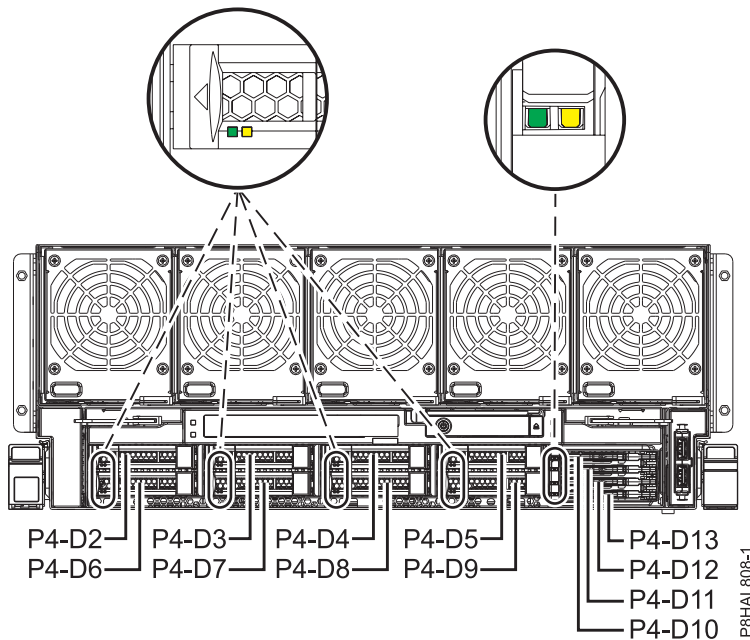

Figure 21. Disk drive and service indicator locations for an 8408-44E or 8408-E8E system

7. To identify the drive by using the diagnostic command before you remove a disk drive or solid-state drive, complete the following steps:
 - a. Log in as root user.
 - b. At the command line, type `diag` and then press Enter.
 - c. On the Diagnostic Operating Instructions display, press Enter to continue.
 - d. On the Function Selection display, select **Task Selection**.
 - e. Select **RAID Array Manager**.
 - f. Select **IBM SAS Disk Array Manager**.
 - g. Select **Diagnostics and Recovery Options**.
 - h. Select **SCSI and SCSI RAID Hot Plug Manager**.
 - i. To identify the location of the drive to be removed, select **Identify a Device Attached to an SCSI Hot Swap Enclosure Device**.

- j. Choose the slot corresponding to the drive, and then press Enter. The identify LED for that slot flashes rapidly.
 - k. Verify that the identify LED for that slot is flashing rapidly, and record the location of the slot.
 - l. Press Enter to stop the LED from flashing and continue.
 - m. To prepare to remove the drive, press **F3** to return to the SCSI and SCSI RAID Hot Plug Manager display.
 - n. Select **Replace/Remove a Device Attached to an SCSI Hot Swap Enclosure Device**.
8. On the console, select the drive that you want to remove, and then press Enter.

Note: When you press Enter, the identify LED stops flashing and is **ON** (solid).

Removing a disk drive or SSD from the 8408-44E or 8408-E8E system with the power turned on in AIX

To remove a disk drive or solid-state drive (SSD) from a system with the AIX operating system or AIX logical partition that controls the drive location powered on, complete the steps in this procedure.

Procedure

1. Ensure that you have the electrostatic discharge (ESD) wrist strap attached. If not, attach it now.
2. Choose from the following options:
 - If you are removing a disk drive or SSD in locations Un-P4-D2 through Un-P4-D9 in an 8408-44E or 8408-E8E system, continue with step 3.
 - If you are removing a 1.8-inch SSD in locations Un-P4-D10 through Un-P4-D13 in an 8408-44E or 8408-E8E system, continue with step 8 on page 35.
3. When the identify LED turns on solid, unlock the drive bay handle (**B**) by pressing the handle latch (**A**) and pulling it out toward you, as shown in Figure 22. If the handle is not all the way out, the solid-state drive cannot slide out of the system.

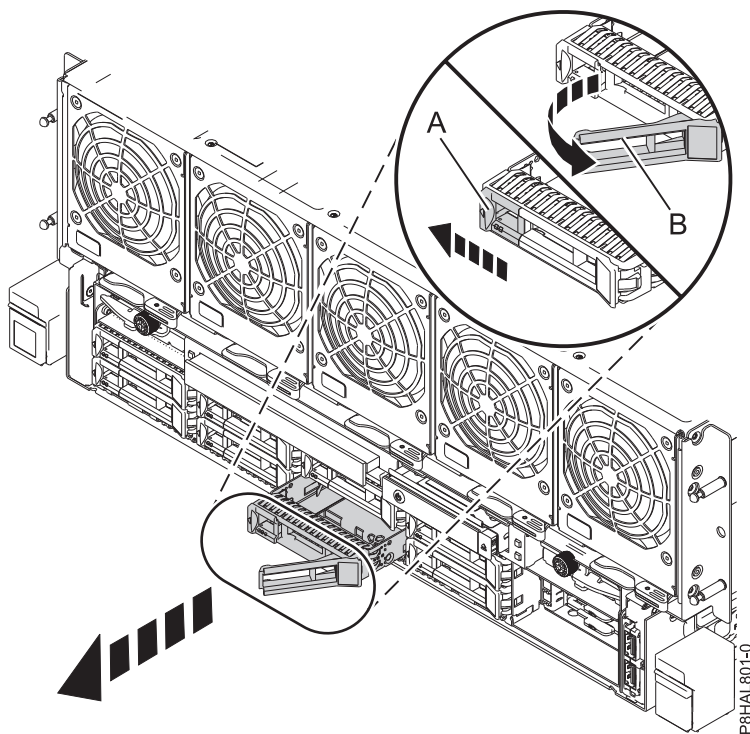

Figure 22. Removing a disk drive from the 8408-44E or 8408-E8E system

4. Support the bottom of the drive as you slide it out of the system. Hold the drive by its sides.
5. Press Enter on the console to indicate that you removed the drive. The identify LED turns off.
6. If you are removing more than one drive, repeat the steps in this procedure until all drives are removed.

Note: If you are not installing a replacement drive, install a filler in the empty slot to ensure proper air flow for cooling. For instructions, see “Installing a disk drive filler in the 8408-44E or 8408-E8E system” on page 50.

7. Proceed to the procedure for replacing a disk drive. For instructions, see “Replacing a disk drive or SSD in the 8408-44E or 8408-E8E system with the power turned on in AIX” on page 36.
8. If you are removing a 1.8-inch SSD in locations Un-P4-D10 through Un-P4-D13 in a system, continue with the next step.
9. Remove the front cover. For instructions, see “Removing the front cover from an 8408-44E or 8408-E8E system” on page 98.

(L007)



CAUTION: A hot surface nearby. (L007)

10. When the identify LED turns on solid, unlock the drive bay handle **(B)** by pushing the handle latch **(A)** in the direction that is shown and pulling the drive bay handle **(B)** out toward you, as shown in Figure 23 on page 36. If the handle is not all the way out, the solid-state drive cannot slide out of the system.

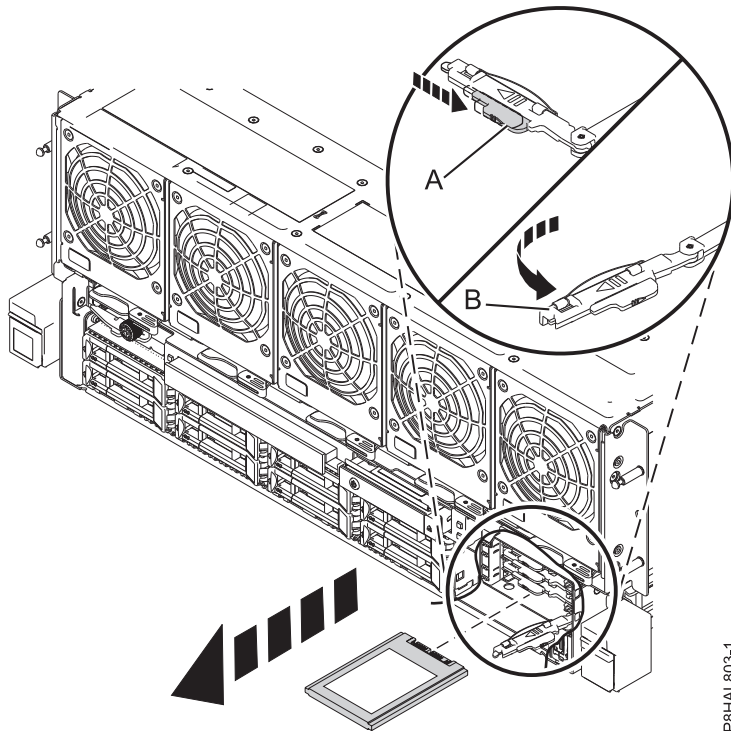

P8HAL803-1

Figure 23. Removing an SSD from an 8408-44E or 8408-E8E system

11. Support the bottom of the drive as you slide it out of the system. Hold the drive by its sides.
12. Press Enter on the console to indicate that you removed the drive. The identify LED turns off.
13. If you are not installing a replacement drive immediately, lock the drive bay handle (B) by rotating it inwards toward the system.
14. If you are removing more than one drive, repeat the steps in this procedure until all drives are removed.

Replacing a disk drive or SSD in the 8408-44E or 8408-E8E system with the power turned on in AIX

To replace a disk drive or solid-state drive (SSD) in a system with the AIX operating system or AIX logical partition that controls the drive location powered on, complete the steps in this procedure.

Procedure

1. Ensure that you have the electrostatic discharge (ESD) wrist strap attached. If not, attach it now.
2. Choose from the following options:
 - If you are replacing a disk drive or SSD in locations Un-P4-D2 through Un-P4-D9 in an 8408-44E or 8408-E8E system, continue with step 3.
 - If you are replacing a 1.8-inch SSD in locations Un-P4-D10 through Un-P4-D13 in an 8408-44E or 8408-E8E system, continue with step 11 on page 37.
3. Unlock the drive bay handle (A) by pressing it and pulling it out toward you. If the handle is not all the way out, the drive does not slide into the system. See Figure 24 on page 37.
4. Hold the drive by the top and bottom edges as you position the drive, and insert it into the drive slot.
5. Slide the drive halfway into the system.
6. On the console, select the drive that you want to install and then press Enter.
7. When the identify LED turns on solid, slide the drive all the way into the system, and push the drive carrier handle (A) in until it locks, as shown in the following figure.

Important: Ensure that the drive is fully seated and is all the way into the system.

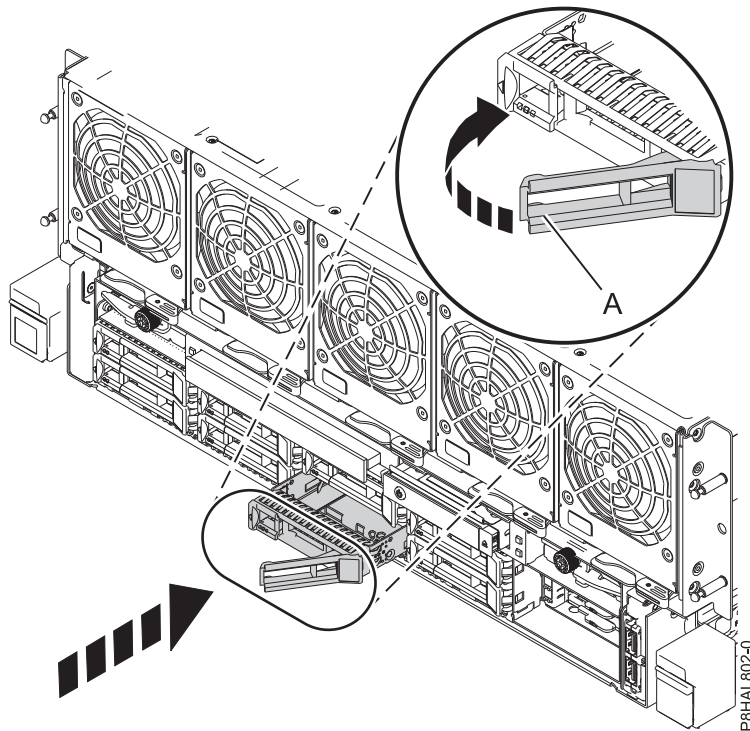

Figure 24. Replacing a disk drive in an 8408-44E or 8408-E8E system

8. On the console, press Enter to indicate that you installed the drive.
9. If you are replacing more than one drive, repeat the steps in this procedure until all drives are replaced.
10. Proceed to the procedure for preparing the system for operation. For instructions, see Preparing the 8408-44E or 8408-E8E system for operation after removing and replacing a disk drive or SSD with the power turned on in AIX.
11. To replace a 1.8-inch SSD in locations Un-P4-D10 through Un-P4-D13 in an 8408-44E or 8408-E8E system, continue with the next step.
12. With the SSD drive bay handle (A) in the unlocked position, pull the lever outward to gain access to the guide rails in the SSD slot. Support the bottom of the SSD as you align it with the guide rails in the SSD slot.

Note: Support the drive by holding the drive by its sides.

13. Slide the drive halfway into the system.
14. On the console, select the drive that you want to install and then press Enter.
15. When the identify LED turns on solid, slide the drive all the way into the system until the drive stops.
16. Lock the drive by rotating the bay handle (A) in the direction that is shown in Figure 25 on page 38.

Important: When you install an SSD, ensure that the SSD is fully seated and is all the way into the system.

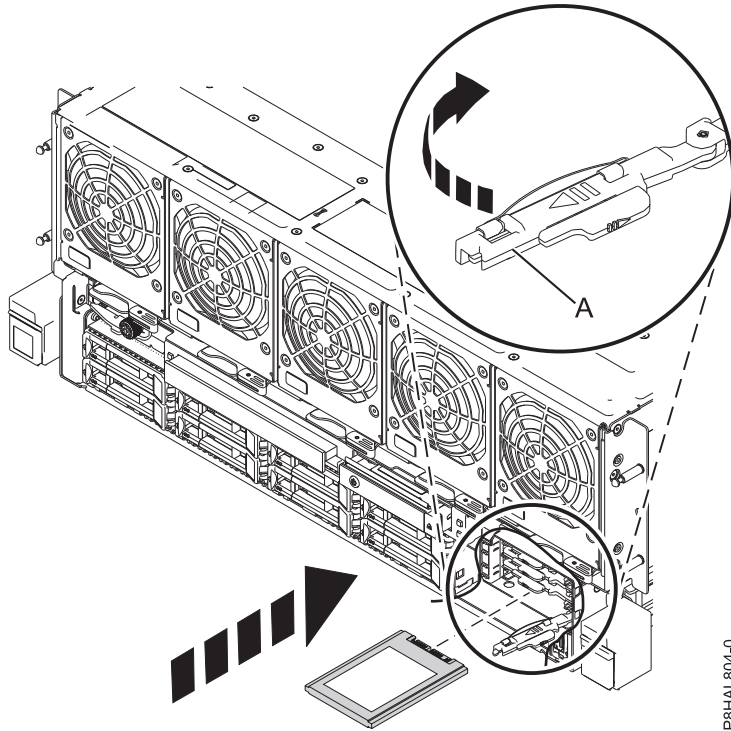

Figure 25. Replacing an SSD in an 8408-44E or 8408-E8E system

17. On the console, press Enter to indicate that you installed the drive.
18. If you are installing more than one drive, repeat the steps in this procedure until all drives are installed.

Preparing the 8408-44E or 8408-E8E system for operation after replacing a drive with the power turned on in AIX

Learn to prepare the system for operation after you replace a disk drive or solid-state drive (SSD) in a system with the AIX operating system or AIX logical partition that controls the drive location powered on.

To prepare the system for operation, complete the following steps:

1. Ensure that you have the electrostatic discharge (ESD) wrist strap attached. If not, attach it now.
2. If you replaced a drive and have not verified the drive yet, verify that the power LED is **ON** (green) and the amber fault LED is **OFF** (not lit) for the replaced drive on the front of the system.
3. If applicable, replace the front cover. For instructions, see “Installing the front cover on an 8408-44E or 8408-E8E system” on page 98.
4. To configure the newly installed disk drive or solid-state drive, see “Configuring a disk drive or solid-state drive for use in an AIX system or AIX logical partition” on page 64.
5. To rebuild the data on the replacement disk drive or solid-state drive, see “Rebuilding data on a replacement disk drive or solid-state drive in a system or logical partition running the AIX operating system” on page 68.

Removing and replacing a disk drive or SSD in the 8408-44E or 8408-E8E with the power turned on in Linux

Learn how to remove and replace a disk drive or solid-state drive (SSD) in a Linux system or a Linux logical partition with the power turned on.

To remove and replace a disk drive or solid-state drive in a system, complete the following steps:

1. "Preparing the 8408-44E or 8408-E8E system to remove and replace a disk drive or SSD with the power turned on in Linux."
2. "Removing a disk drive or SSD from the 8408-44E or 8408-E8E system with the power turned on in Linux" on page 43.
3. "Replacing a disk drive or SSD in the 8408-44E or 8408-E8E system with the power turned on in Linux" on page 45.
4. "Preparing the 8408-44E or 8408-E8E system for operation after removing and replacing a drive with the power turned on in Linux" on page 48.

Note: Removing or replacing this feature is a customer task. You can complete this task yourself, or contact a service provider to complete the task for you. You might be charged a fee by the service provider for this service.

Preparing the 8408-44E or 8408-E8E system to remove and replace a disk drive or SSD with the power turned on in Linux

Learn about the steps you must complete before you remove and replace a disk drive or solid-state drive (SSD) in a system, with the Linux operating system or Linux logical partition that controls the drive location powered on.

If the drive that you are removing is in the root volume group (rootvg) and it is not protected by either Redundant Array of Independent Disks (RAID) or mirroring, or to use the powered-off procedure, go to "Removing and replacing a disk drive or solid-state drive in the 8408-44E or 8408-E8E with the system power turned off" on page 24.

To prepare the system to remove and replace a disk drive or solid-state drive, complete the following steps:

1. Identify the part and the system that you want to service. The disk drive and SSD slots are in the front of a system.

Figure 26 on page 40 shows the disk drive and solid-state drive locations and service indicators. Service indicators are located above the latch handle on the disk drives.

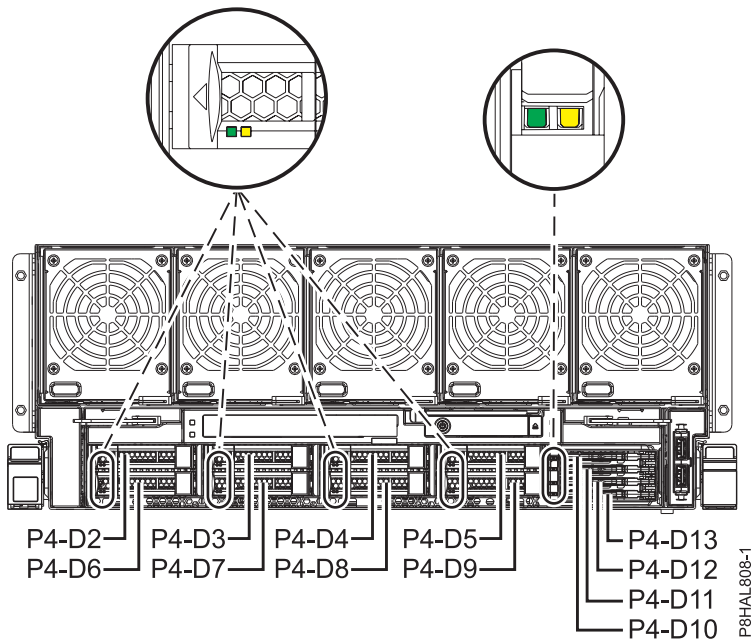

Figure 26. Disk drive and service indicator locations for an 8408-44E or 8408-E8E system

2. Find the package that contains the new drive.

Attention: Drives are fragile. Handle with care.

3. Attach the electrostatic discharge (ESD) wrist strap.

Attention:

- Attach an electrostatic discharge (ESD) wrist strap to the front ESD jack, to the rear ESD jack, or to an unpainted metal surface of your hardware to prevent the electrostatic discharge from damaging your hardware.
- When you use an ESD wrist strap, follow all electrical safety procedures. An ESD wrist strap is used for static control. It does not increase or decrease your risk of receiving electric shock when using or working on electrical equipment.
- If you do not have an ESD wrist strap, just prior to removing the product from ESD packaging and installing or replacing hardware, touch an unpainted metal surface of the system for a minimum of 5 seconds.

4. Remove the drive from the static-protective package and place it on an ESD mat.

5. To identify the drive by using the **iprconfig** command before you remove a disk drive or solid-state drive, complete the following steps:

- a. Log in as root user.
- b. Type **iprconfig** on the command line of the Linux session and press Enter. The IBM Power RAID Configuration Utility display is shown.
- c. Select **Analyze log**. Press Enter. The Kernel Messages Log display is shown.

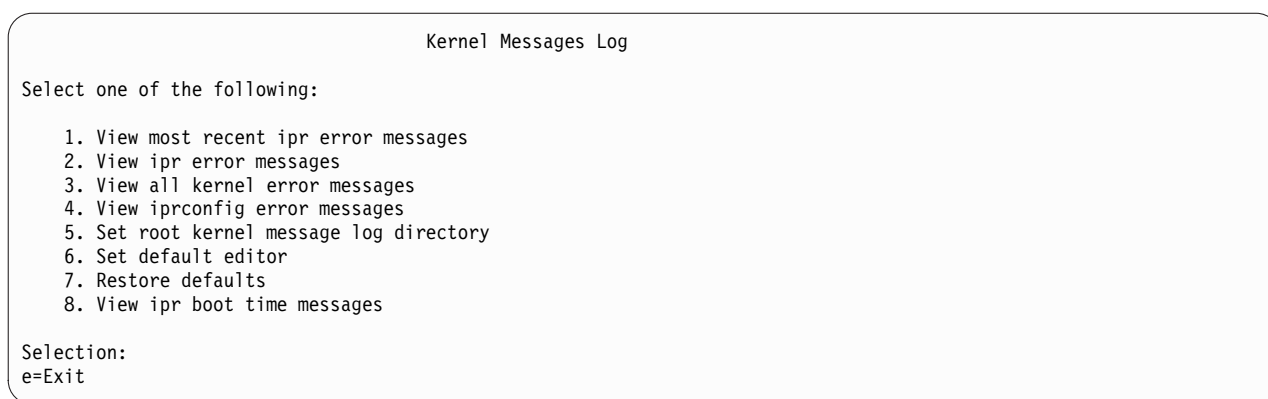

Figure 27. Kernel Messages Log

- d. Select **View most recent ipr error messages** from the Kernel Messages Log display. Press Enter.
- e. Find the entry in the log for the drive you want to replace.
- f. Record the location information for the drive.

Note: The location information is in either of these forms:

0:0:5:0 In this example, 0 is the SCSI host number, 0 is the SCSI bus, 5 is the SCSI target ID, and 0 is the logical unit number (LUN).

0/00-0E-02

In this example, 0 is the SCSI host number, 00 is the I/O adapter (IOA) SAS port, 0E is the expander port, and 02 is the device port.

- g. Type iprconfig on the command line and press Enter. The IBM Power RAID Configuration Utility display is shown.
- h. Select **Display hardware status** from the IBM Power RAID Configuration Utility display. Press Enter. The Display Hardware Status screen displays as shown in Figure 28 and Figure 29 on page 42.

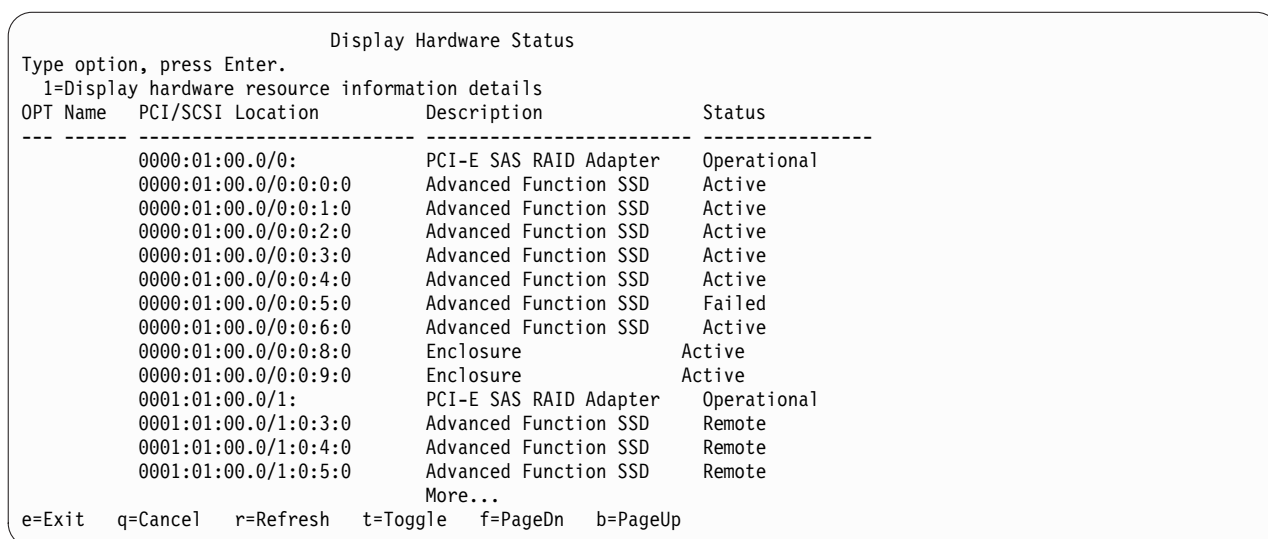

Figure 28. Example Display Hardware Status

```

Display Hardware Status
Type option, press Enter.
l=Display hardware resource information details
OPT Name Resource Path/Address Vendor Product ID Status
-----
sg23 FE IBM 57CE001SISIOA Operational
sg0 00-0E-01 IBM SG9XCA2E200GEIBM Active
sg1 00-0E-0A IBM SG9XCA2E200GEIBM Active
sg2 00-0E-0B IBM SG9XCA2E200GEIBM Active
sg3 00-0E-03 IBM SG9XCA2E200GEIBM Active
sg4 00-0E-09 IBM SG9XCA2E200GEIBM Active
sg5 00-0E-02 IBM SG9XCA2E200GEIBM Failed
sg6 00-0E-04 IBM SG9XCA2E200GEIBM Active
sg7 00-0C-26 IBM 5887 Active
sg8 00-0E-26 IBM 5887 Active
sg47 FE IBM 57CE001SISIOA Operational
sg26 00-0E-01 IBM SG9XCA2E200GEIBM Remote
sg27 00-0E-0A IBM SG9XCA2E200GEIBM Remote
sg28 00-0E-0B IBM SG9XCA2E200GEIBM Remote
More...
e=Exit q=Cancel r=Refresh t=Toggle f=PageDn b=PageUp

```

Figure 29. Example Display Hardware Status

- i. If the drive you want to replace is unprotected or in use, move the data from the drive before you continue with this procedure. If the drive is in a RAID 0 (non-redundant RAID array), after you move the data, delete the RAID 0 before proceeding. For SAS RAID controller information, see the SAS RAID controllers for Linux (http://www.ibm.com/support/knowledgecenter/POWER8/p8ebk/p8ebk_kickoff.htm).
- j. Look for the drive at the SCSI location you recorded. The drive might have a Failed status.
- k. Return to the IBM Power RAID Configuration Utility display.
- l. If you are removing a solid-state device that is on a PCIe RAID and SSD SAS adapter, go to Removing and replacing the SAS RAID adapter (<http://www.ibm.com/support/knowledgecenter/POWER8/p8ebj/p7ebjBDRemoveReplace.htm>), and complete that procedure.
- m. From the IBM Power RAID Configuration Utility display, select **Work with disk unit recovery**. Press Enter.
- n. From the Work with Disk Unit Recovery display, select **Concurrent remove device**, and press Enter. A Concurrent Device Remove display is shown, similar to the following examples shown in Figure 30 and Figure 31 on page 43.

```

Concurrent Device Remove
Choose a single location for remove operations
l=Select
OPT Name PCI/SCSI Location Description Status
-----
sg0 U5887.001.Z065075-P1-D1 Empty
sg5 U5887.001.Z065075-P1-D2 Advanced Function SSD Active
sg3 U5887.001.Z065075-P1-D3 Advanced Function SSD Failed
sg6 U5887.001.Z065075-P1-D4 Advanced Function SSD Active
U5887.001.Z065075-P1-D5 Advanced Function SSD Active
U5887.001.Z065075-P1-D6 Empty
U5887.001.Z065075-P1-D7 Empty
U5887.001.Z065075-P1-D8 Empty
U5887.001.Z065075-P1-D9 Empty
sg4 U5887.001.Z065075-P1-D10 Advanced Function SSD Active
sg1 U5887.001.Z065075-P1-D11 Advanced Function SSD Active
sg2 U5887.001.Z065075-P1-D12 Advanced Function SSD Active

```

Figure 30. Example Concurrent Device Remove display

Concurrent Device Remove				
Choose a single location for remove operations				
1=Select				
OPT Name	SCSI Host/Resource Path	Vendor	Product ID	Status
	0/00-0E-00			Empty
sg0	0/00-0E-01	IBM	SG9XCA2E200GEIBM	Active
sg5	0/00-0E-02	IBM	SG9XCA2E200GEIBM	Failed
sg3	0/00-0E-03	IBM	SG9XCA2E200GEIBM	Active
sg6	0/00-0E-04	IBM	SG9XCA2E200GEIBM	Active
	0/00-0E-05			Empty
	0/00-0E-06			Empty
	0/00-0E-07			Empty
	0/00-0E-08			Empty
sg4	0/00-0E-09	IBM	SG9XCA2E200GEIBM	Active
sg1	0/00-0E-0A	IBM	SG9XCA2E200GEIBM	Active
sg2	0/00-0E-0B	IBM	SG9XCA2E200GEIBM	Active
e=Exit	q=Cancel	t=Toggle		

Figure 31. Example Concurrent Device Remove display

- o. Press T to toggle between the Concurrent Device Remove panels.
- p. Type 1 (Select) next to the location for this drive (0:0:5:0 or 0/00-0E-02). The Verify Device Concurrent Remove display is shown. The service indicator flashes for that drive slot.

Removing a disk drive or SSD from the 8408-44E or 8408-E8E system with the power turned on in Linux

To remove a disk drive or solid-state drive (SSD) from a system with the Linux operating system or Linux logical partition that controls the drive location powered on, complete the steps in this procedure.

Procedure

1. Ensure that you have the electrostatic discharge (ESD) wrist strap attached. If not, attach it now.
2. Choose from the following options:
 - If you are removing a disk drive or SSD in locations Un-P4-D2 through Un-P4-D9 in an 8408-44E or 8408-E8E system, continue with step 3.
 - If you are removing a 1.8-inch SSD in locations Un-P4-D10 through Un-P4-D13 in an 8408-44E or 8408-E8E system, continue with step 7 on page 44.
3. When the identify LED flashes, unlock the drive bay handle (**B**) by pressing the handle latch (**A**) and pulling it out toward you, as shown in Figure 32 on page 44. If the handle is not all the way out, the solid-state drive cannot slide out of the system.

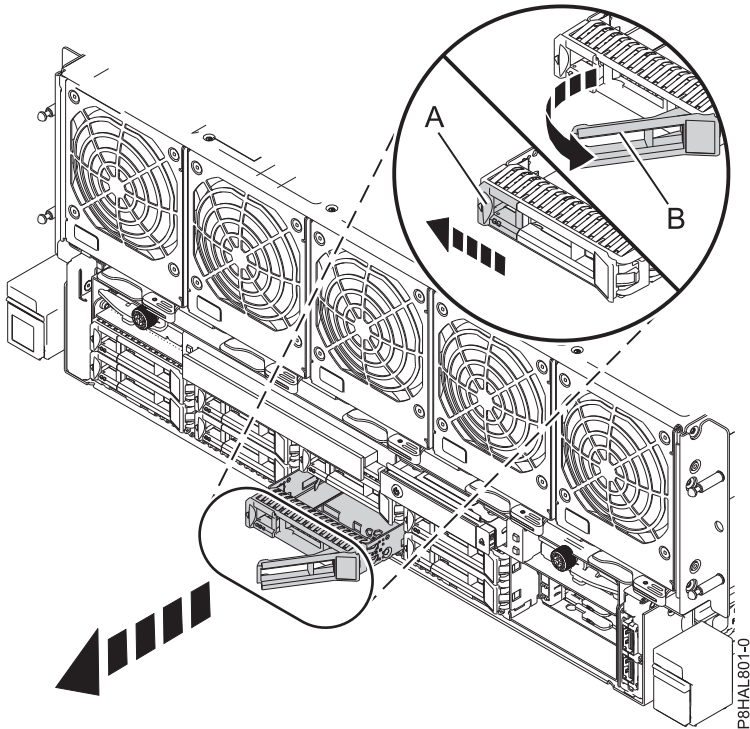

Figure 32. Removing a disk drive from the 8408-44E or 8408-E8E system

4. Support the bottom of the drive as you slide it out of the system. Hold the drive by its sides.
5. If you are removing more than one drive, repeat the steps in this procedure until all drives are removed.

Note: If you are not installing a replacement drive, install a filler in the empty slot to ensure proper air flow for cooling. For instructions, see “Installing a disk drive filler in the 8408-44E or 8408-E8E system” on page 50.

6. Proceed to the procedure for replacing a disk drive. For instructions, see “Replacing a disk drive or SSD in the 8408-44E or 8408-E8E system with the power turned on in Linux” on page 45.
7. To remove a 1.8-inch SSD in locations Un-P4-D10 through Un-P4-D13 in an 8408-44E or 8408-E8E system, continue with the next step.
8. Remove the front cover. For instructions, see “Removing the front cover from an 8408-44E or 8408-E8E system” on page 98.

(L007)



CAUTION: A hot surface nearby. (L007)

9. When the identify LED turns on solid, unlock the drive bay handle (**B**) by pushing the handle latch (**A**) in the direction that is shown and pulling the drive bay handle (**B**) out toward you, as shown in Figure 33 on page 45. If the handle is not all the way out, the solid-state drive cannot slide out of the

system.

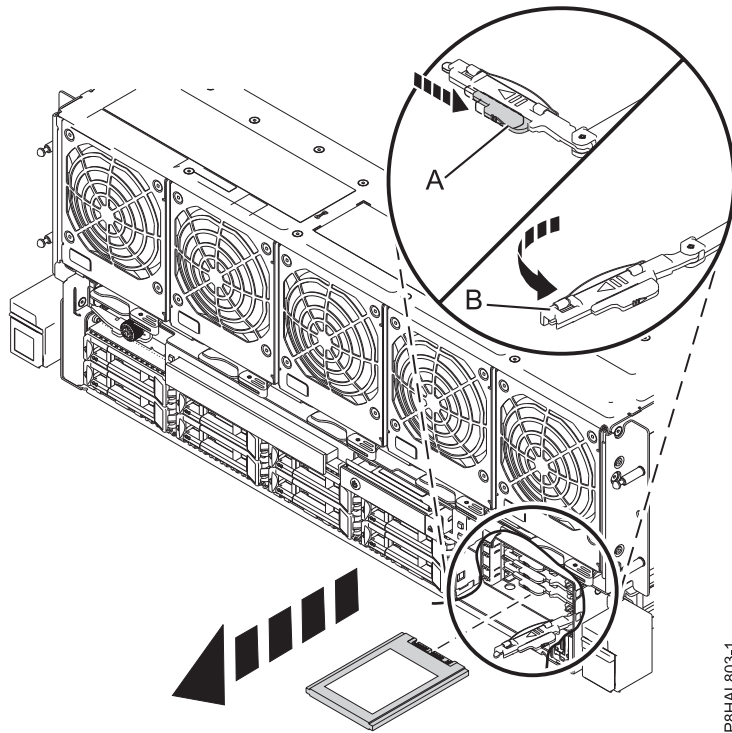

Figure 33. Removing an SSD from an 8408-44E or 8408-E8E system

10. Support the bottom of the drive as you slide it out of the system. Hold the drive by its sides.
11. If you are not installing a replacement drive immediately, lock the drive bay handle (B) by rotating it inwards toward the system.
12. If you are removing more than one drive, repeat the steps in this procedure until all drives are removed.

Replacing a disk drive or SSD in the 8408-44E or 8408-E8E system with the power turned on in Linux

To replace a disk drive or solid-state drive (SSD) in a system with the Linux operating system or Linux logical partition that controls the drive location powered on, complete the steps in this procedure.

Procedure

1. Ensure that you have the electrostatic discharge (ESD) wrist strap attached. If not, attach it now.
2. Choose from the following options:
 - If you are replacing a disk drive or SSD in locations Un-P4-D2 through Un-P4-D9 in an 8408-44E or 8408-E8E system, continue with step 3.
 - If you are replacing a 1.8-inch SSD in locations Un-P4-D10 through Un-P4-D13 in an 8408-44E or 8408-E8E system, continue with step 11 on page 47.
3. On the console, complete the following steps:
 - a. From the IBM Power RAID Configuration Utility display, select **Work with disk unit recovery**, and then press Enter.
 - b. From the Work with Disk Unit Recovery display, select **Concurrent add device**. Press Enter. A Concurrent Device Add display similar to the following example is shown.

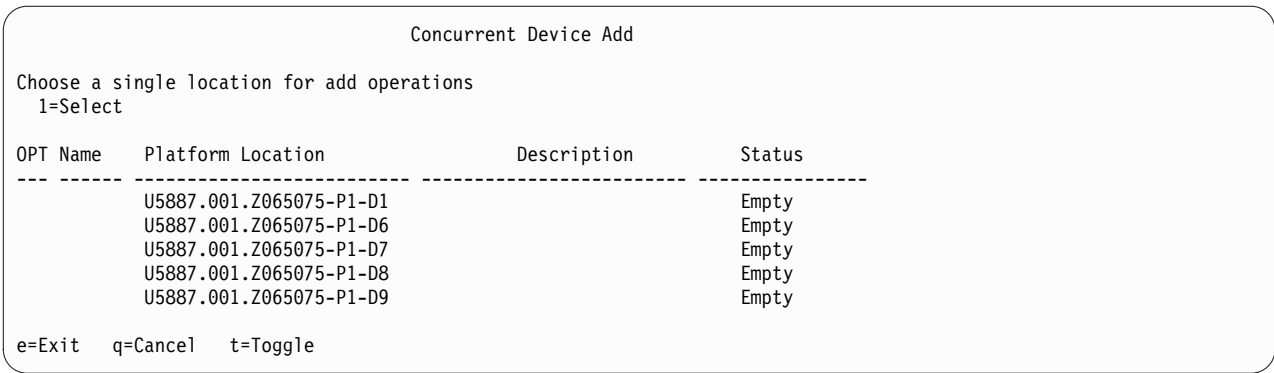

Figure 34. Example Concurrent Device Add display

- c. Type 1 (Select) next to the location from which you removed the disk drive or solid-state drive. The Verify Device Concurrent Add display is shown. The service indicator flashes for that drive slot.
4. Unlock the drive bay handle (A) by pressing it and pulling it out toward you. If the handle is not all the way out, the drive does not slide into the system. See Figure 35.
5. Hold the drive by the top and bottom edges as you position the drive, and insert it into the drive slot.
6. Slide the drive halfway into the system.
7. Return to the console, and then press Enter. In the Verify Device Concurrent Add display, verify that the selected slot is the slot in which you want to install the drive.
8. When the identify LED flashes for the selected slot, slide the drive all the way into the slot, and push the drive bay handle (A) in until it locks, as shown in Figure 35

Important: Ensure that the drive is fully seated and is all the way into the system.

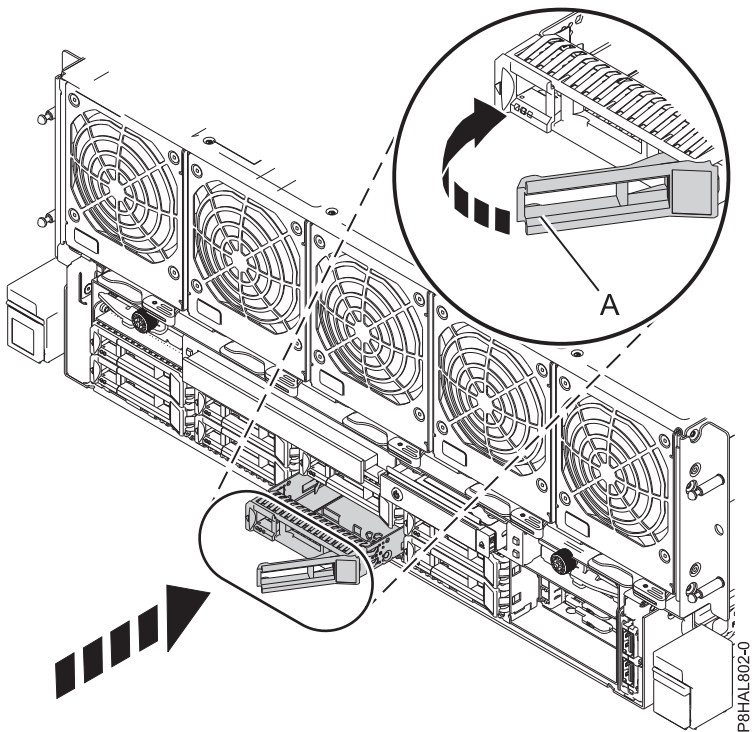

Figure 35. Replacing a disk drive in an 8408-44E or 8408-E8E system

9. On the console, press Enter on the Complete Device Concurrent Add display to indicate that the drive is installed. The service indicator stops flashing and turns off for that drive slot.
10. If you are replacing more than one drive, repeat the steps in this procedure until all drives are replaced.
11. To replace a 1.8-inch SSD in locations Un-P4-D10 through Un-P4-D13 in an 8408-44E or 8408-E8E system, continue with the next step.
12. On the console, complete the following steps:
 - a. From the IBM Power RAID Configuration Utility display, select **Work with disk unit recovery**, and then press Enter.
 - b. From the Work with Disk Unit Recovery display, select **Concurrent add device**. Press Enter. A Concurrent Device Add display similar to the following example is shown.

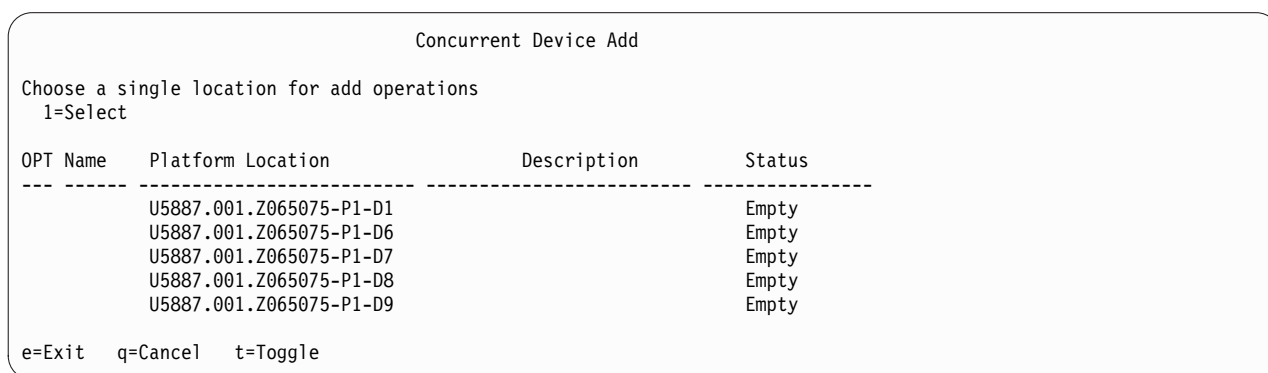

Figure 36. Example Concurrent Device Add display

- c. Type 1 (Select) next to the location from which you removed the disk drive or solid-state drive. The Verify Device Concurrent Add display is shown. The service indicator flashes for that drive slot.
13. With the SSD drive bay handle **(A)** in the unlocked position, pull the lever outward to gain access to the guide rails in the SSD slot. Support the bottom of the SSD as you align it with the guide rails in the SSD slot. See Figure 37 on page 48.

Note: Support the drive by holding the drive by its sides.

14. Slide the drive halfway into the system.
15. On the console, press Enter on the Complete Device Concurrent Add display to indicate that the drive is installed. The service indicator stops flashing and turns off for that drive slot.
16. When the identify LED flashes for the selected slot, slide the drive all the way into the slot until the drive stops.
17. Lock the drive by rotating the bay handle **(A)** in the direction that is shown in Figure 37 on page 48.

Important: When you install an SSD, ensure that the SSD is fully seated and is all the way into the system.

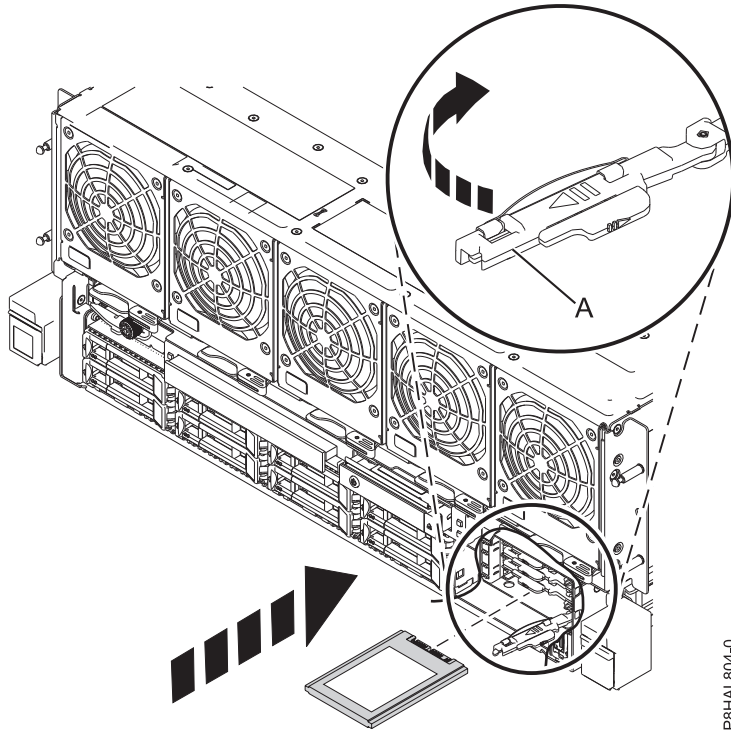

Figure 37. Replacing an SSD in an 8408-44E or 8408-E8E system

18. On the console, press Enter on the Complete Device Concurrent Add display to indicate that the drive is installed. The service indicator stops flashing and turns off for that drive slot.
19. If you are installing more than one drive, repeat the steps in this procedure until all drives are installed.

Preparing the 8408-44E or 8408-E8E system for operation after removing and replacing a drive with the power turned on in Linux

Learn to prepare the system for operation after you replace a disk drive or solid-state drive (SSD) in a system with the Linux operating system or Linux logical partition that controls the drive location powered on.

To prepare the system for operation, complete the following steps:

1. To verify that the new disk drive or solid-state drive is operational, complete the following steps:
 - a. Log in as root user.
 - b. Type `iprconfig` on the command line of the Linux session and press Enter. The IBM Power RAID Configuration Utility display is shown.
 - c. Select **Display hardware status**. The Display Hardware Status display is shown, similar to the following figure.

```

Display Hardware Status

Type option, press Enter.
l=Display hardware resource information details

OPT Name      PCI/SCSI Location      Description      Status
-----
0000:01:00.0/0:      PCI-E SAS RAID Adapter      Operational
0000:01:00.0/0:0:0:0      Advanced Function SSD      Active
0000:01:00.0/0:0:1:0      Advanced Function SSD      Active
0000:01:00.0/0:0:2:0      Advanced Function SSD      Active
0000:01:00.0/0:0:3:0      Advanced Function SSD      Active
0000:01:00.0/0:0:4:0      Advanced Function SSD      Active
0000:01:00.0/0:0:5:0      Advanced Function SSD      Active
0000:01:00.0/0:0:6:0      Advanced Function SSD      Active
0000:01:00.0/0:0:8:0      Enclosure                   Active
0000:01:00.0/0:0:9:0      Enclosure                   Active
0001:01:00.0/1:      PCI-E SAS RAID Adapter      Operational
0001:01:00.0/1:0:3:0      Advanced Function SSD      Remote
0001:01:00.0/1:0:4:0      Advanced Function SSD      Remote
0001:01:00.0/1:0:5:0      Advanced Function SSD      Remote
More...

e=Exit  q=Cancel  r=Refresh  t=Toggle  f=PageDn  b=PageUp

```

Figure 38. Example Display Hardware Status

- d. Verify that the disk drive or solid-state drive that you installed is shown on this display.
2. Ensure that you have the electrostatic discharge (ESD) wrist strap attached. If not, attach it now.
3. If applicable, replace the front cover. For instructions, see “Installing the front cover on an 8408-44E or 8408-E8E system” on page 98.
4. If you replaced a drive and have not verified the drive yet, verify that the power LED is **ON** (green) and the amber fault LED is **OFF** (not lit) for the replaced drive on the front of the system.
5. To configure the newly installed disk drive or solid-state drive, see “Configuring a disk drive or solid-state drive for use in an Linux system or Linux logical partition” on page 67.
6. To rebuild data on the newly installed or replaced disk drive or solid-state drive, see “Rebuilding data on a replacement disk drive or solid-state drive in a system or logical partition that is running the Linux operating system” on page 69.

Related procedures for installing, removing, and replacing disk drives or solid-state drives

Find procedures that are related to installing, removing, and replacing disk drives or solid-state drives for an 8408-44E or 8408-E8E system.

Removing and installing a disk drive filler

Find information about removing and installing a Small Computer System Interface (SCSI) disk drive filler for a system, drive enclosure, or an expansion unit.

Note: Refill the disk drive or solid-state drive slots with either another disk drive or solid-state drive or a disk drive filler. Filling the disk drive slot ensures proper air flow for cooling and maintains an optimal electromagnetic interference (EMI) compliance.

Removing a disk drive filler from the 8408-44E or 8408-E8E

Find information about removing a disk drive or solid-state drive (SSD) filler from the system, drive enclosure, or an expansion unit.

When you are installing a disk drive or SSD in a system, drive enclosure, or an expansion unit, the slot you want to use can contain a disk drive filler. To remove the filler before you install a disk drive or SSD in the slot, complete the following steps:

1. Identify the slot that contains the disk drive filler.
2. If you do not have a wrist strap that is attached, attach the wrist strap.

Attention:

- Attach an electrostatic discharge (ESD) wrist strap to the front ESD jack, to the rear ESD jack, or to an unpainted metal surface of your hardware to prevent the electrostatic discharge from damaging your hardware.
 - When you use an ESD wrist strap, follow all electrical safety procedures. An ESD wrist strap is used for static control. It does not increase or decrease your risk of receiving electric shock when using or working on electrical equipment.
 - If you do not have an ESD wrist strap, just prior to removing the product from ESD packaging and installing or replacing hardware, touch an unpainted metal surface of the system for a minimum of 5 seconds.
3. Push the lock (A) on the handle of the filler in the direction shown in Figure 39.
 4. Hold the handle and pull out the filler from the slot.

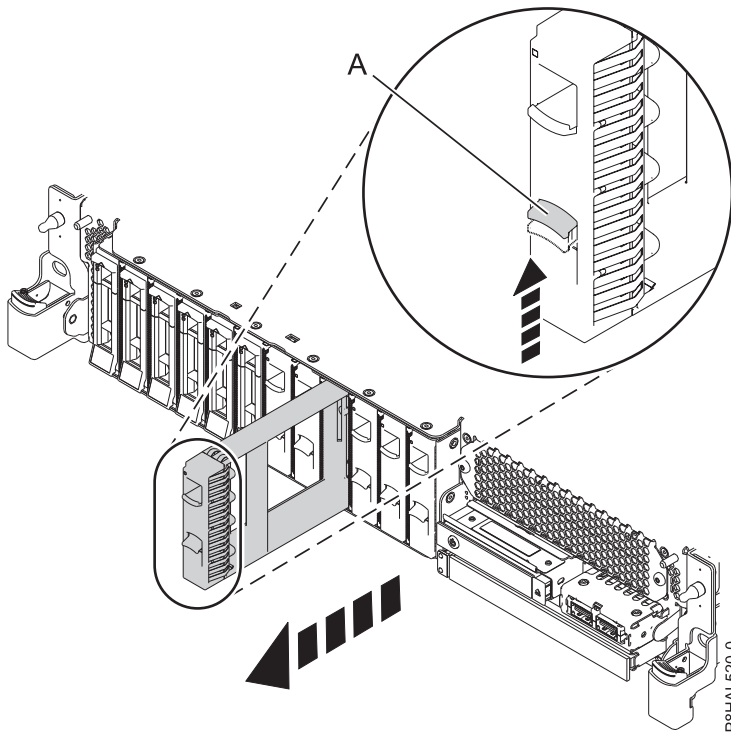

Figure 39. Removing a disk drive filler from a system

Return to the procedure that brought you here.

Installing a disk drive filler in the 8408-44E or 8408-E8E system

Find information about installing a disk drive or solid-state drive (SSD) filler in the system, drive enclosure, or an expansion unit.

When you remove a disk drive or an SSD from a system, drive enclosure, or an expansion unit, you can install a disk drive filler in the slot if you are not installing a replacement drive. To install a disk drive filler, complete the following steps:

1. Ensure that you have the electrostatic discharge (ESD) wrist strap attached. If not, attach it now.

2. Hold the disk drive filler by the top and bottom edges as you position the filler, and insert it into the system, drive enclosure, or the expansion unit.

Attention:

- Attach an electrostatic discharge (ESD) wrist strap to the front ESD jack, to the rear ESD jack, or to an unpainted metal surface of your hardware to prevent the electrostatic discharge from damaging your hardware.
 - When you use an ESD wrist strap, follow all electrical safety procedures. An ESD wrist strap is used for static control. It does not increase or decrease your risk of receiving electric shock when using or working on electrical equipment.
 - If you do not have an ESD wrist strap, just prior to removing the product from ESD packaging and installing or replacing hardware, touch an unpainted metal surface of the system for a minimum of 5 seconds.
3. Align the disk drive filler with the drive slot and push the disk drive filler all the way into the system (A) until it locks, as shown in Figure 40.

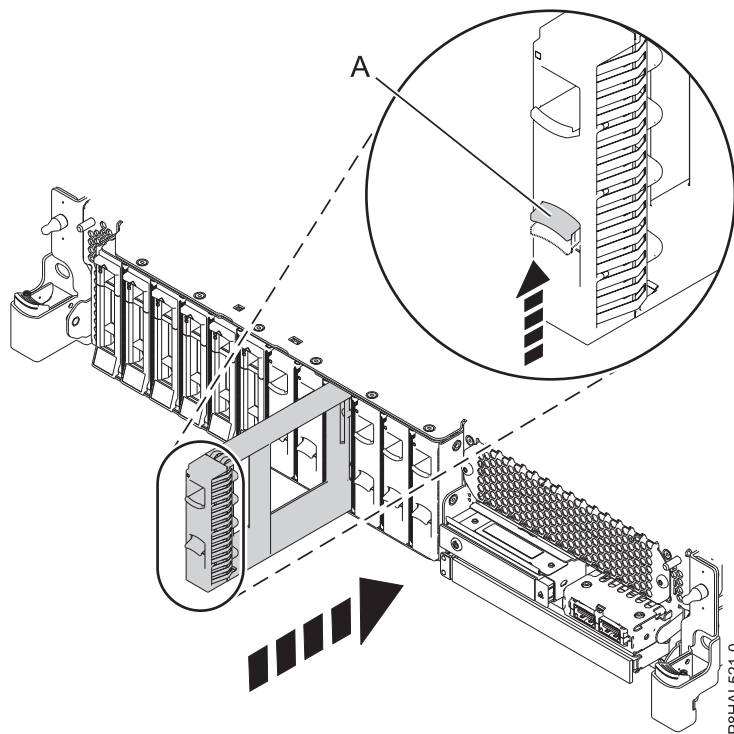

Figure 40. Installing a disk drive filler in a system

Return to the procedure that brought you here.

Disk drive or solid-state drive locations and service indicators

Find out where the disk drives or solid-state drives (SSDs) and service indicators are on the system or disk drive enclosure.

Learn about the disk drives or SSD locations and the location of the service indicators on the system or enclosure. If you are using logical partitions, go to Partitioning the server (http://www.ibm.com/support/knowledgecenter/POWER8/p8hat/p8hat_kickoff.htm) for more information.

Disk drive and SSD locations and service indicators for the 8408-44E or 8408-E8E system

Learn about the disk drive and solid-state drive (SSD) locations and understand where the service indicators are located for your system.

Figure 41 show the disk drive and solid-state drive locations and service indicators for the 8408-44E or 8408-E8E system. Service indicators are located above the latch handle on the drives.

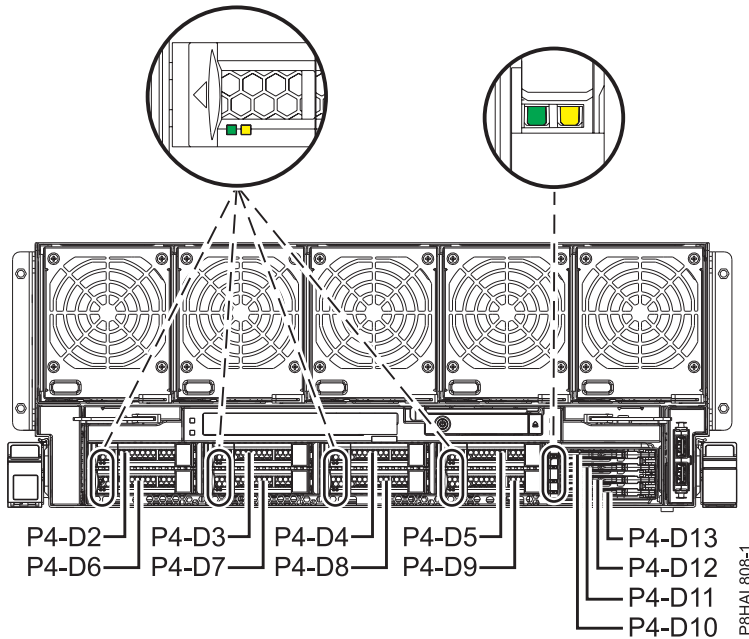

Figure 41. Disk drive and SSD and service indicator locations for an 8408-44E or 8408-E8E system

Disk drive locations and service indicators for the 5887 disk drive enclosure

Learn about the disk drive locations and where the service indicators are located for the 5887 disk drive enclosure.

Figure 42 and Figure 43 on page 53 show the front view and rear view of the 5887 disk drive enclosure and the disk drive locations in the 5887 disk drive enclosure.

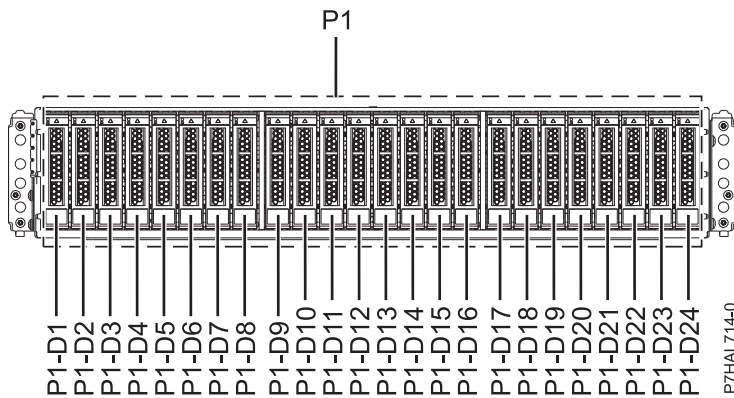

Figure 42. Front view of the 5887 disk drive enclosure showing the disk drive locations

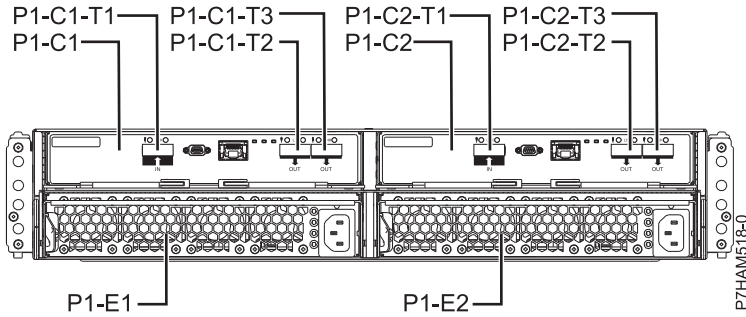

Figure 43. Rear view of the 5887 disk drive enclosure

Figure 44 shows the locations of the disk drive service indicators for the 5887 disk drive enclosure.

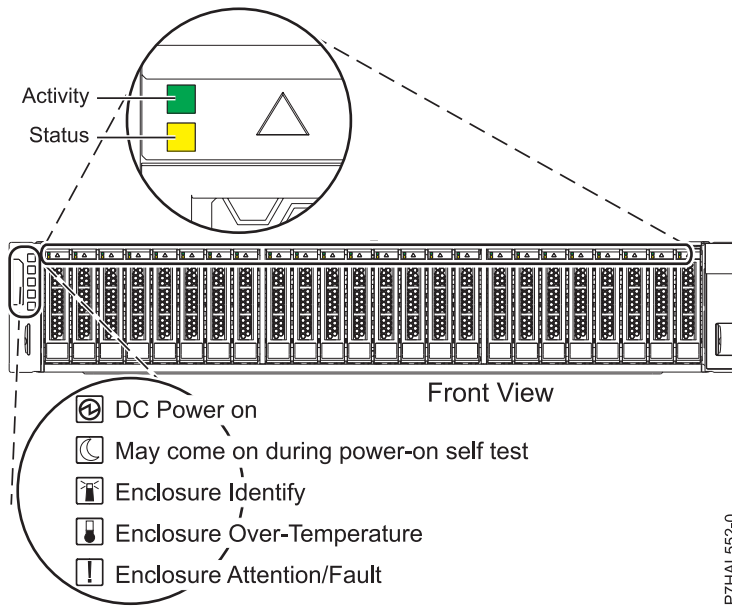

Figure 44. Front view of the 5887 disk drive enclosure showing the service indicators

Disk drive locations and service indicators for the ESLL and ESLS storage enclosures

Learn about the disk drive locations and where the service indicators are located for the ESLL and ESLS storage enclosures.

Figure 45 on page 54 shows the front of the ESLL storage enclosure, Figure 46 on page 54 shows the front of the ESLS storage enclosure, Figure 47 on page 54 shows the rear view of the storage enclosures, and Figure 48 on page 55 shows the locations of the disk drive service indicators for the enclosures.

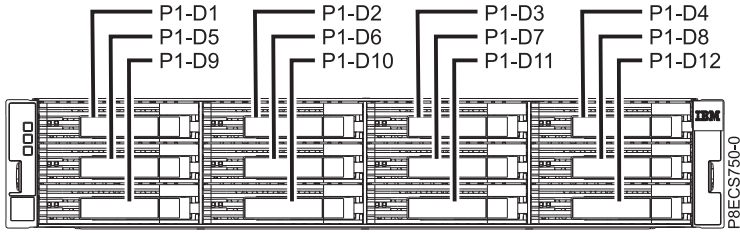

Figure 45. Front view of the ESLL storage enclosure showing the disk drive locations

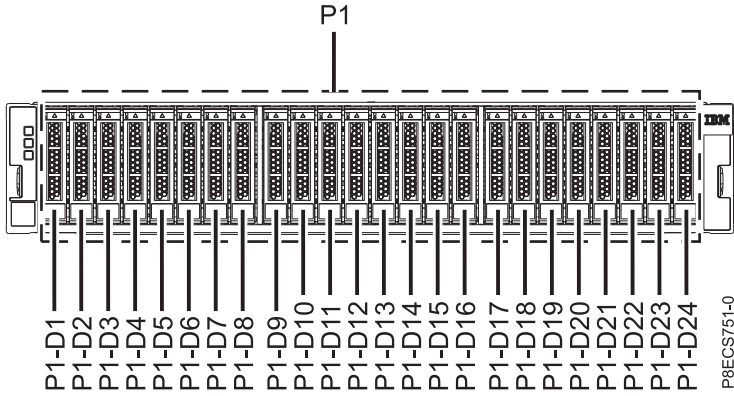

Figure 46. Front view of the ESLS storage enclosure showing the disk drive locations

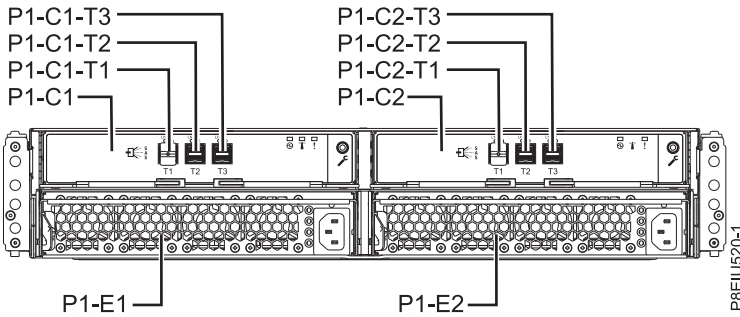

Figure 47. Rear view of the enclosure

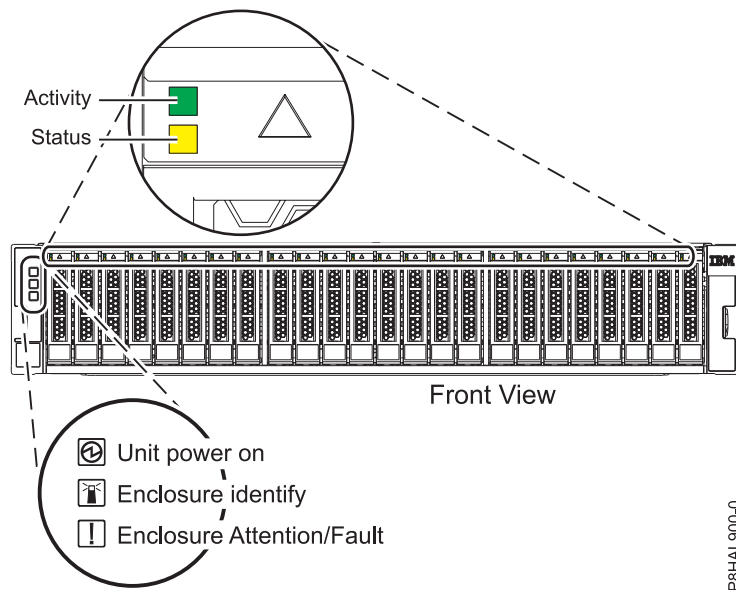

Figure 48. Front view of the enclosure showing the service indicators

Solid-state drive configuration rules

Find information about configuration details of the solid-state drives (SSDs) before you install them in the system, enclosure, or an expansion unit.

Solid-state drives (SSDs), also known as flash drives, follow similar rules as regular hard disk drives (HDDs). For example, SSDs physically resemble, install in the same manner, and in most of the same slots as HDDs. However, some restrictions and configuration rules are specific to the SSD.

After you review the configuration rules, you can install the drive as you would any other disk drive.

Attention: Before you install an SSD in your system, ensure that both the SSD and the adapters have all the prerequisite updates. To check for the prerequisites, go to the IBM Prerequisite website (www-912.ibm.com/e_dir/eServerPrereq.nsf).

The following tables help you to determine the operating system, adapter, machine type model, and disk drive configuration rules that apply to your system or disk drive enclosure.

Restriction: Solid-state drives must be part of a RAID array or system mirroring in the system or logical partition that is controlled by IBM i.

Choose the system or enclosure you want to view the configuration rules for:

- Solid-state drive rules for the 5148-21L, 5148-22L, 8247-21L, 8247-22L, 8284-21A, or 8284-22A
- Solid-state drive rules for the 8247-42L, 8286-41A, or 8286-42A
- Solid-state drive rules for the 8408-44E or 8408-E8E
- Solid-state drive rules for the 5887 disk drive enclosure
- ESLS storage enclosure

Note: The ESLL storage enclosure does not use solid-state drives.

Solid-state drive rules for the 5148-21L, 5148-22L, 8247-21L, 8247-22L, 8284-21A, or 8284-22A

Table 1. Solid-state drive rules for the 5148-21L, 5148-22L, 8247-21L, 8247-22L, 8284-21A, or 8284-22A system.

System	Adapter	Mixing rules
8247-21L or 8247-22L	PCIe3 x8 SAS RAID internal adapter 6 Gb (FC EL3V; CCIN 57D7)	<ul style="list-style-type: none"> FC EL3V can be used to split the disk backplane into two sets of 6 disks. HDDs can be configured as just a bunch of disks (JBOD) or in RAID 0, 5, 6, and 10. SSDs must be configured in RAID 0, 5, 6, or 10. SSDs and HDDs can be mixed within each side of a split disk backplane, but cannot be mixed in the same RAID array.
8284-21A or 8284-22A	PCIe3 x8 SAS RAID internal adapter 6 Gb (FC EJ0V; CCIN 57D7)	<ul style="list-style-type: none"> FC EJ0V can be used to split the disk backplane into two sets of 6 disks. HDDs can be configured as JBOD or in RAID 0, 5, 6, and 10. SSDs must be configured in RAID 0, 5, 6, or 10. SSDs and HDDs can be mixed within each side of a split disk backplane, but cannot be mixed in the same RAID array.

Solid-state drive rules for the 8247-42L, 8286-41A, or 8286-42A

Table 2. Solid-state drive rules for the 8247-42L, 8286-41A, or 8286-42A system.

System, enclosure, or expansion unit	Adapter	Mixing rules
8247-42L, 8286-41A, or 8286-42A	PCIe3 x8 SAS RAID internal adapter 6 Gb (FC EJ0N; CCIN 57D7)	<ul style="list-style-type: none"> FC EJ0N can be used to configure up to 12 disks on a single controller. Disks can be configured as just a bunch of disks (JBOD) or in RAID 0, 5, 6, and 10, depending on the OS support. SSDs must be configured in RAID 0, 5, 6, or 10. SSDs and HDDs can be mixed in the disk drive backplane, but cannot be mixed in the same RAID array.
8286-41A or 8286-42A	PCIe3 x8 SAS RAID internal adapter 6 Gb (FC EJ0S; Dual CCIN 57D7)	<ul style="list-style-type: none"> FC EJ0S can be used to split the disk backplane into two sets of 6 disks that use two controllers. HDDs can be configured as JBOD or in RAID 0, 5, 6, and 10 depending on the OS support. SSDs must be configured in RAID 0, 5, 6, or 10. SSDs and HDDs can be mixed within each side of a split disk backplane, but cannot be mixed in the same RAID array.
	PCIe3 x8 cache SAS RAID internal adapter 6 Gb expanded function (FC EJ0P; Dual CCIN 57D8)	<ul style="list-style-type: none"> FC EJ0P can be used to configure up to 26 disks in the 8286-42A and up to 18 disks in the 8286-41A, with dual SAS paths that use expanded function controllers and disk drive backplane. SSDs and HDDs can be configured in RAID 0, 5, 6, 10, 5T2, 6T2, and 10T2 depending on the OS support. (JBOD is not supported.) SSDs and HDDs can be mixed within the expanded function disk drive backplane. Feature code EJ0P also allows two external SAS ports and the attachment of an external 5887 disk drive enclosure.

Solid-state drive rules for the 8408-44E or 8408-E8E

Table 3. Solid-state drive rules for the 8408-44E or 8408-E8E system.

System	Controller	Mixing rules
8408-44E or 8408-E8E	PCIe3 x8 cache SAS RAID internal controller 6 Gb (FC EPVN; Dual CCIN 2CCA)	<ul style="list-style-type: none"> • Dual SAS RAID controllers • Dual write cache RAID • 8x SFF 2.5 in. plus 4x 1.8 in. SDD • SSDs and HDDs can be mixed in the SFF 2.5 in. bays, but cannot be mixed in the same RAID array. • SSDs and HDDs can be configured in RAID 0, 10, 5, 6, 5T2, 6T2, 10T2, depending on the OS support. (JBOD is not supported.)
	PCIe3 x8 SAS RAID internal controller 6 Gb (FC EPVP; Dual CCIN 2CD2)	<ul style="list-style-type: none"> • Dual SAS RAID controllers • No write cache RAID • 8x SFF 2.5 in. plus 4x 1.8 in. SDD • SSDs and HDDs can be mixed in the SFF 2.5 in. bays, but cannot be mixed in the same RAID array. • SSDs and HDDs can be configured in RAID 0, 10, 5, 6, 5T2, 6T2, 10T2, depending on the OS support. (JBOD is not supported.)
	PCIe3 x8 SAS RAID internal controller 6 Gb (FC EPVQ); Two single controllers (CCIN 2CCD)	<ul style="list-style-type: none"> • Two single SAS RAID controllers • Each controller owns 4x SFF 2.5 in. plus 2x 1.8 in. SDD • SSDs and HDDs can be mixed within each side of a split disk backplane in the SFF 2.5 in. bays, but cannot be mixed in the same RAID array. • HDDs can be configured as just a bunch of disks (JBOD) or in RAID 0, 10, 5, 6, 10T2, depending on the OS support. • SSDs must be configured in RAID 0, 5, 6, 10, or 10T2.

Solid-state drive rules for the 5887 disk drive enclosure

Table 4. Solid-state drive rules for the 5887 disk drive enclosure.

Disk drive enclosure	Mixing rules
5887 disk drive enclosure (EXP24S SFF Gen2-bay Drawer)	<ul style="list-style-type: none"> • A maximum of 24 drives are supported in this enclosure. • The EXP24S can be configured as one set of 24 bays (mode 1), two sets of 12 bays (mode 2), or four sets of 6 bays (mode 4). • The EXP24S serial-attached SCSI (SAS) ports are attached to SAS controllers, which can be a SAS Peripheral Component Interconnect-X (PCI-X) adapter, PCI Express (PCIe) adapter, PCI Express Gen2 (PCIE2), PCI Express Gen3 (PCIe3) adapter or a pair of adapters. • The EXP24S can also be attached to a pair of internal SAS controllers (FC EJ0U) in a system with an external SAS port. • The mixing of the SSDs and HDDs is as follows: <ul style="list-style-type: none"> – SSDs and HDDs cannot be mixed when configured in mode 1. – SSDs and HDDs can be mixed when configured in mode 2: one disk partition can be SSDs and the other disk partition can be HDDs, but you cannot mix within a disk partition. – SSDs and HDDs can be mixed when configured in mode 4 depending on the adapter support. Each disk partition can be either SSDs or HDDs, but cannot mix within a disk partition.

Solid-state drive rules for the ESLS storage enclosure

Table 5. Solid-state drive rules for the ESLS storage enclosure.

Storage enclosure	Mixing rules
ESLS storage enclosure (IBM EXP24SX SAS Storage Enclosure)	<ul style="list-style-type: none">• A maximum of 24 drives are supported in this enclosure.• The EXP24SX can be configured as one set of 24 bays (mode 1), two sets of 12 bays (mode 2), or four sets of 6 bays (mode 4).• The EXP24SX serial-attached SCSI (SAS) ports are attached to SAS controllers, which can be a SAS Peripheral Component Interconnect-X (PCI-X) adapter, PCI Express (PCIe) adapter, PCI Express Gen2 (PCIE2), PCI Express Gen3 (PCIe3) adapter or a pair of adapters.• The EXP24S can also be attached to a pair of internal SAS controllers (FC EJ0U) in a system with an external SAS port.• The mixing of the SSDs and HDDs is as follows:<ul style="list-style-type: none">– SSDs and HDDs cannot be mixed when configured in mode 1.– SSDs and HDDs can be mixed when configured in mode 2: one disk partition can be SSDs and the other disk partition can be HDDs, but you cannot mix within a disk partition.– SSDs and HDDs can be mixed when configured in mode 4 depending on the adapter support. Each disk partition can be either SSDs or HDDs, but cannot mix within a disk partition.

Mainstream solid-state drives

Learn about the differences between enterprise solid-state drives (SSDs) and mainstream SSDs (previously called read intensive SSDs).

Traditionally, enterprise SSDs are built on high-endurance multi-level cell (MLC) flash and can handle up to 10 drive writes per day. These SSDs are referred to as *enterprise SSDs* in this document (previously called eMLC). Now, because of software advances and industry demands, less write intensive SSDs can be used with applications where write operations are less frequent. IBM offers several 4K mainstream SSDs, including feature codes (FCs) ES8Y, ES8Z, ES96, ES97, ESE7, ESE8, ES83, ES84, ES92, ES93, ESE1, and ESE2.

Differences between mainstream and enterprise SSDs

Mainstream SSDs are less expensive to use, but also have lower endurance and random write performance.

Lower endurance for mainstream drives

The NAND flash used in mainstream drives tend to be of lower endurance than the NAND flash used in SSDs that are targeted for the more write intensive workloads. Therefore, the number of write operations to a mainstream drive is limited (typically, one drive write per day (DWPD) versus 10 DWPD on an enterprise drive).

A *drive write per day* writes the entire capacity of the drive in 24 hours. For example, a DWPD for a 387 GB drive writes 387 GB of data on the drive in 24 hours. You can write more data in a day, but the DWPD is the average usage rate by which the life span of the drive is calculated. Since many applications only require about 1 DWPD, these are the most commonly used drives in the industry and thus used for mainstream applications. Only applications that require high endurance or the highest random write performance need enterprise drives.

Lower over-provisioning for mainstream drives

SSDs have more NAND flash capacity than the rated user capacity of the drive. This extra capacity, called *over-provisioning*, is used by the SSD controller during the operation of the drive. When more over-provisioning is available, the controller extends the life of the flash more effectively. NAND flash can be written (programmed) and read in small units that are called *pages*, individually, but to rewrite that page, the page must first be erased and then programmed again.

Due to the architecture of NAND flash, erase operations are completed on the block level and not the page level. Each block contains hundreds to thousands of pages. Therefore, to erase a block, all of the valid data must first be transferred to another block and then you can erase the block. The SSD controller then searches for blocks with large proportions of pages that have data that can be erased. Then, the SSD controller moves and combines the pages of data that must be retained to previously erased blocks, which then frees these new blocks for erasing.

This process of moving data to free up blocks for erasing is called *garbage collection*. Increasing the over-provisioning of an SSD enables the controller to be more efficient in garbage collection and minimizes extra read and program operations.

All of these background operations result in more data that is written to the flash than what is written to the drive. The ratio of data that is written to flash and the data that is written to the drive is referred to as the *write amplification*. All else being equal, write amplification is greater for drives with lower over-provisioning.

Lower cost for mainstream drives

The cost per GB of a mainstream drive is typically less than the cost per GB of an enterprise drive. The cost is low because the amount of over-provisioning is less and almost all the flash memory in the drive is available for storing data.

Lower write operation performance for mainstream drives

Mainstream drives are similar to enterprise drives in terms of read performance. However, because of the lower over-provisioning of the mainstream drives, the random write performance is reduced because of the higher number of background operations that are needed for garbage collection and associated write amplification. Thus, lower over-provisioning decreases both performance and endurance. Read performance is not impacted.

No mixing of mainstream drives with enterprise drives in disk arrays

Endurance differences imply that when you form disk arrays, you must not mix mainstream drives with enterprise drives because the PCIe SAS adapter stripes data across drives, thus sending equal data to each drive. The IBM PCIe SAS adapters do not allow mixing of mainstream drives with enterprise drives when you create RAID arrays.

Monitoring end of life for mainstream drives

You must monitor end of life symptoms for mainstream drives because of their endurance limitations. Internally, when the drive nears the end of life, a predictive failure analysis (PFA) trip is generated and an operating system message is logged. When this trip is generated, the drive continues to run but it must be replaced as soon as possible. The PFA trip code for end of life is the same as the PFA trip code for thermal failures. Therefore, you can determine the root cause of a failure by using operating system support that is provided by a fuel gauge command.

Warranty and maintenance information for mainstream SSDs

A mainstream drive is not suitable for write intensive workloads. Assuming a typical heavily random workload, at about 3394 TB of write operations to a 1.9 TB mainstream drive, the drive is at its maximum

projected write capability. If the write operations exceed the drive's maximum write capacity, the write operation takes more time to complete. A predictive failure analysis (PFA) message indicates that you should replace the drive.

If you ignore the PFA message and if you continue to send the write operation requests to the drive, the drive is unable to accept write commands and only accepts read commands for some time. A failed write operation results in a more serious error message that indicates that the drive must be replaced.

The nature of the workload impacts the maximum write operation capacity. For example, if a high percentage of sequentially oriented write operations is used instead of random oriented write operations, the maximum write operation capacity increases. You must periodically check the percentage of the drive's remaining write life, and if necessary, adjust the workload or reassign the drive. Check the remaining life on each of the mainstream drives individually, even if all of the drives are in the same array.

If a mainstream drive reaches its maximum write operation capability during the warranty period, IBM replaces the drive at no cost. The warranty period of the drive is defined by the server type under which the drive feature code is ordered and it is either 3 years or 1 year for IBM Power Systems™ processor-based servers. After the warranty period, the replacement of the drive is not covered under IBM maintenance if the maximum number of write operations exceed the threshold value. You must order a new, chargeable SSD as a replacement. Other aspects of SSD maintenance are consistent with SSDs that are not mainstream drives.

Using the fuel gauge command

The fuel gauge command is an operating system command that you can use to determine the amount of life in a drive. When a PFA trip is reported by the drive, you can use the fuel gauge command to determine the remaining life on the mainstream drive. Then, you can decide whether the drive reached end of life or if the PFA trip occurred for another reason.

Note: The fuel gauge command does not apply to the IBM Elastic Storage Server Data Server 5147-024 storage enclosure SSD drives currently.

For instructions about using the fuel gauge command, select the option for the operating system you are using:

- Using the AIX fuel gauge command
- Using the IBM i fuel gauge tool
- Using the Linux fuel gauge command

Using the AIX fuel gauge command

Learn how to use the AIX operating system fuel gauge command to find the amount of remaining life in a mainstream solid-state drive (SSD).

To use the fuel gauge tool for the AIX operating system, complete the following steps:

1. If the system has logical partitions, complete this procedure from the logical partition that reported the problem.
2. From the AIX command line, type the following command and press Enter:
`/usr/lpp/diagnostics/bin/pdiskfg -d pdiskX`, where X is the pdisk number of the mainstream SSD.
3. Is the value in the **Life Remaining Gauge** field less than or equal to 2 percent?
 - **Yes:** Continue with the next step.
 - **No:** The mainstream SSD is not reporting a change in status for the number of write operations available.
4. Is the value in the **Life Remaining Gauge** field 0 percent?

- **Yes:** Continue with step 5.
 - **No:** Continue with step 6.
5. The mainstream SSD reached the limit for the number of write operations that are supported. Write operations to the SSD become slower over time, and at some point the SSD becomes a read-only drive. When the operating system writes to the read-only drive, the write operations are rejected, and the operating system considers the drive as if a failure occurred. For example, if the operating system writes to a drive that is in a RAID array and if the write operations are rejected, the array becomes exposed. To support normal write operations, the drive must be replaced.
Replacement of the mainstream SSD might not be covered by the system's level of service entitlement, depending on the terms and conditions of the system. For more information about mainstream SSDs, see "Mainstream solid-state drives" on page 58. **This ends the procedure.**
 6. The mainstream SSD is nearing the limit for the number of write operations that are supported. No service action is required at this time.

Note: After the mainstream SSD reaches the limit for the number of write operations that are supported, write operations to the SSD become slower over time, and at some point the SSD becomes a read-only drive. To support normal write operations, the drive must be replaced. Replacement of the mainstream SSD might not be covered by the system's level of service entitlement, depending on the terms and conditions of the system. For more information about mainstream SSDs, see "Mainstream solid-state drives" on page 58. **This ends the procedure.**

Using the IBM i fuel gauge tool

Learn how to use the IBM i operating system fuel gauge tool to find the amount of remaining life in a mainstream solid-state drive (SSD).

To use the fuel gauge tool for the IBM i operating system, complete the following steps:

1. If the system has logical partitions, complete this procedure from the logical partition that owns the SSD.
2. Sign on to an IBM i session with the QSECOFR user profile.
3. To create a report in a spoolfile, type the following command at the XPF command line and press Enter.
`CALL PGM(QSMGSSTD) PARM('SSDGAUGE' X'00000008' 'SSTD0100' X'00000000')`
4. Display the contents of the spool file. The spool file contains a report for mainstream SSDs. For each of the SSDs in the report, continue with the next step.
5. Is the value in the **Life Remaining Gauge** field less than or equal to 2 percent?
 - **Yes:** Continue with the next step.
 - **No:** The mainstream SSD is not reporting a change in status for the number of write operations available.
6. Is the value in the **Life Remaining Gauge** field 0 percent?
 - **Yes:** Continue with the next step.
 - **No:** Continue with step 8.
7. The mainstream SSD reached the limit for the number of write operations that are supported. Write operations to the SSD become slower over time, and at some point the SSD becomes a read-only drive. When the operating system writes to the read-only drive, the write operations are rejected, and the operating system considers the drive as if a failure occurred. For example, if the operating system writes to a drive that is in a RAID array and if the write operations are rejected, the array becomes exposed. To support normal write operations, the drive must be replaced.
Replacement of the mainstream SSD might not be covered by the system's level of service entitlement, depending on the terms and conditions of the system. For more information about mainstream SSDs, see "Mainstream solid-state drives" on page 58. **This ends the procedure.**
8. The mainstream SSD is nearing the limit for the number of write operations that are supported. No service action is required at this time.

Note: After the mainstream SSD reaches the limit for the number of write operations that are supported, write operations to the SSD become slower over time, and at some point the SSD becomes a read-only drive. To support normal write operations, the drive must be replaced. Replacement of the mainstream SSD might not be covered by the system's level of service entitlement, depending on the terms and conditions of the system. For more information about mainstream SSDs, see “Mainstream solid-state drives” on page 58. **This ends the procedure.**

Using the Linux fuel gauge command

Learn how to use the Linux operating system fuel gauge command to find the amount of remaining life in a mainstream solid-state drive (SSD).

To use the fuel gauge tool for the Linux operating system, complete the following steps:

1. If the system has logical partitions, complete this procedure from the logical partition that reported the problem.
2. Choose from the following options:
 - To use the **iprconfig** command, continue with step 3.
 - To use the **ssd-report** command in the **iprutils** command-line interface, continue with step 9.
3. In the command line, enter the following command:
`$ iprconfig`
4. In the main menu, select the **Devices Statistics** option.
5. In the Device selection screen, select **Read Intensive SSD (Mainstream SSD)** by moving the cursor to the correct line and pressing **1**.
6. Press Enter to confirm. The statistics for the selected device is shown.
7. Review the information in the first block of information.
8. Continue with step 10.
9. To use the **ssd-report** command in the **iprutils** command-line interface, complete the following steps:
 - a. Type `$ iprconfig -c ssd-report <dev>`
Where `<dev>` is the device you want to use.
 - b. Review the information that is shown.
 - c. Continue with step 10.
10. Interpret the statistics:
 - **Total Bytes Written:** Number of GB already written to the device
 - **Number of Bytes reported by Warranty:** Number of GBs that can be written according to the specification
 - **Life Remaining Gauge:** An estimate of how much of the device's life has been consumed
 - **PFA Trip:** The device has detected an issue that could lead to a failure
 - **Power-on Days:** Number of days since the last power-on
11. Is the value in the **Life Remaining Gauge** field less than or equal to 2 percent?
 - **Yes:** Continue with the next step.
 - **No:** The mainstream SSD is not reporting a change in status for the number of write operations available.
12. Is the value in the **Life Remaining Gauge** field 0 percent?
 - **Yes:** Continue with step 13.
 - **No:** Continue with step 14 on page 63.
13. The mainstream SSD reached the limit for the number of write operations that are supported. Write operations to the SSD become slower over time, and at some point the SSD becomes a read-only drive. When the operating system writes to the read-only drive, the write operations are rejected, and the operating system considers the drive as if a failure occurred. For example, if the operating

system writes to a drive that is in a RAID array and if the write operations are rejected, the array becomes exposed. To support normal write operations, the drive must be replaced.

Replacement of the mainstream SSD might not be covered by the system's level of service entitlement, depending on the terms and conditions of the system. For more information about mainstream SSDs, see "Mainstream solid-state drives" on page 58. **This ends the procedure.**

14. The mainstream SSD is nearing the limit for the number of write operations that are supported. No service action is required at this time.

Note: After the mainstream SSD reaches the limit for the number of write operations that are supported, write operations to the SSD become slower over time, and at some point the SSD becomes a read-only drive. To support normal write operations, the drive must be replaced. Replacement of the mainstream SSD might not be covered by the system's level of service entitlement, depending on the terms and conditions of the system. For more information about mainstream SSDs, see "Mainstream solid-state drives" on page 58. **This ends the procedure.**

Preparing the system to remove a disk drive or solid-state drive

Find information about preparing the system to remove a drive by using your operating system.

Preparing the system to remove a disk drive or solid-state drive in AIX

Find information about the actions you must take to properly remove a disk drive or solid-state drive from a system, drive enclosure, or an expansion unit that is controlled by the AIX operating system.

Before you remove a drive from a system that is controlled by the AIX operating system, ensure that all data on that drive or the array that contains the drive is backed up and removed from the drive. If the drive that is being replaced is protected by RAID or mirroring, it is not necessary to remove data. Ensure that the disks are in the defined state if the disks are just a bunch of disks (JBOD).

If the drive is attached to a SAS RAID controller, see SAS RAID controllers for AIX.

More information is available at the IBM AIX IBM Knowledge Center website (http://www.ibm.com/support/knowledgecenter/ssw_aix).

Preparing the system to remove a disk drive or solid-state drive from a system or logical partition controlled by IBM i

Find information about the actions you must take to properly remove a disk drive or solid-state drive from a system, drive enclosure, or an expansion unit that is controlled by the IBM i operating system.

Before removing a drive from a system, drive enclosure, or an expansion unit that is controlled by the IBM i operating system, complete the following steps:

1. Determine the protection status of the drive that you are replacing. For instructions, see "Determining the disk drive or solid-state drive protection status in the IBM i operating system" on page 67.
2. **For mirrored disk drives** on an IBM i system or an IBM i logical partition, follow these steps to verify that the drive you are replacing has been suspended:
 - a. Sign on with service level authority.
 - b. Type `strsst` on the command line of the IBM i session, and then press Enter.
 - c. Type your service tools user ID and service tools password on the Start Service Tools (STRSST) Sign On display, and then press Enter.

Remember: The service tools password is case-sensitive.

- d. Select **Work with disk units** from the System Service Tools (SST) display, and then press Enter.
- e. Select **Display Disk Configuration** from the Work with Disk Units display, and then press Enter.
- f. Select **Display Disk Configuration Status** from the Display Disk Configuration display, and then press Enter.

- g. Does the drive that is mirrored to the drive that you are replacing (same drive number) have a status of Active?
- **No:** The replacement must be done by a service provider.
 - **Yes:** Does the drive that you are replacing have a status of Suspended?
 - **Yes:** Continue with the next step.
 - **No:** Follow these steps to suspend mirrored protection on the drive that you are replacing:
 - 1) Press F3 from the Display Disk Configuration display to return to the Work with Disk Units display.
 - 2) Select **Work with Disk Unit Recovery** from the Work with Disk Units display, and then press Enter.
 - 3) Select **Suspend mirrored protection** from the Work with Disk Unit Recovery display, and then press Enter.
 - 4) Select the option to suspend the drive that you are replacing from the Suspend Mirrored Protection display, and then press Enter.
- h. Press F3 repeatedly to exit System Service Tools and return to the main menu.

Preparing the system to remove a disk drive or solid-state drive in Linux

Find information about the actions you must take to properly remove a disk drive or solid-state drive from a system, drive enclosure, or an expansion unit that is controlled by the Linux operating system.

Before removing a drive from a system, drive enclosure, or an expansion unit that is controlled by the Linux operating system, ensure that all data on that drive or the array that contains the drive is backed up and removed from the drive.

If the drive is attached to a SAS RAID controller, see SAS RAID controllers for Linux (http://www.ibm.com/support/knowledgecenter/POWER8/p8ebk/p8ebk_kickoff.htm).

Configuring a disk drive or solid-state drive

Find information about configuring a disk drive or solid-state drive by using your operating system.

Configuring a disk drive or solid-state drive for use in an AIX system or AIX logical partition

Configure the newly installed disk drive or solid-state drive (SSD) for your environment.

See the *AIX System Management Guide: Operating System and Devices*.

This guide is available at the IBM AIX Knowledge Center website (http://www-01.ibm.com/support/knowledgecenter/ssw_aix/welcome).

Configuring a disk drive or solid-state drive for use in an IBM i system or IBM i logical partition

Configure the newly installed disk drive or solid-state drive (SSD) for your environment.

If you want to start a new device parity set or change the protection on your disks, go to the IBM i Knowledge Center website (http://www-01.ibm.com/support/knowledgecenter/ssw_ibm_i/welcome) and select the version of the IBM i operating system you are using. Then, select **Systems management > Disk management > Disk protection > Device parity protection**.

Attention: Due to a potential large performance degradation, POWER8® systems do not allow the **Include disk** operation. Alternatively, you can stop parity on the existing set and then start parity with more disks in the set, or you can create a new parity set consisting of three or more drives.

To configure a newly installed disk drive or solid-state drive (SSD) for your environment, complete the following steps:

1. If necessary, start System Service Tools (SST) by typing **strsst** on the command line of the IBM i session, and then press Enter.
2. Type your service tools user ID and service tools password on the Start Service Tools (STRSST) Sign On display, and then press Enter.

Restriction: The service tools password is case-sensitive.

3. Select **Work with Disk Units** on the System Service Tools display, and then press Enter.
4. Select **Display disk configuration** on the Work with Disk Units display, and then press Enter.
5. Select **Display non-configured units** on the Display disk configuration display, and then press Enter.
6. The drives that you installed are listed. The serial numbers must match the serial numbers that you recorded (the last four digits).

Note: The new drives might take up to five minutes to appear in the list. If the drive is not listed, ensure that the drives were installed properly.

7. Press **F12** twice.
8. Select **Work with disk configuration** on the Work with Disk Units display, and then press Enter.
9. Choose from the following options:
 - To continue with device parity, go to step 10.
 - To configure mirroring or no protection, go to step 17.
 - To configure for hot spare, go to step 23 on page 66.
10. Select **Work with device parity protection** on the Work with Disk Configuration display, and then press Enter.
11. The following conditions must be met before you can start device parity protection.
 - If there are enough drives available to create a new parity set, the drives are eligible for *Start Device Parity Protection* operation.
 - All drives in a parity set must be the same capacity with a minimum number of two, three, or four drives (depending on RAID level) and maximum of 32 drives in the resulting parity set.
 - Not all drives that are attached to an advanced function input/output adapter have been reported to the system. Repeat the operation.
 - The type or model of the drives cannot be used for the requested operation.When these conditions are met and Device Parity is started, press **F12** to return to the Work with Disk Configuration display.
12. Select **Display disk configuration** on the Work with disk configuration display, and then press Enter.
13. Select **Display disk configuration status** on the Display disk configuration display.
14. If you have more than one auxiliary storage pool (ASP), determine the ASP to which you want to add the drive.
15. Press **F12** twice to get to the Work with Disk Units display.
16. Select **Work with disk configuration** on the Work with Disk Units display, and then press Enter.
17. Select the option to add units to ASPs and balance data on the Work with disk configuration display. Press Enter.
18. Specify the number of the ASP to which you want to add the drive, and then press Enter. The system ASP is **ASP 1**.

Notes:

- a. If ASP is mirror protected, disk drives must be added in pairs of the same size.

- b. When one or more pairs of disk drives are added to a mirrored ASP, they automatically become mirror protected.
 - c. To start mirrored protection on an ASP, go to the IBM i Knowledge Center website (http://www-01.ibm.com/support/knowledgecenter/ssw_ibm_i/welcome) and select the version of the IBM i operating system you are using. Then, select **Systems management > Backup and recovery > Recovering your system**.
19. The Confirm Add Units display shows the configuration that your system must have when the add operation completes.

Note: If you selected the wrong ASP, press **F12** to change your options. Press the Enter to continue. The add process takes several minutes to complete.

20. When the message Selected units have been added successfully is shown, press **F3** three times and press Enter to return to the Main menu display.
21. If you have a printer, print the configuration list. A service provider might refer to the configuration list in the future.
- a. You must sign on **with at least service level authority**
 - b. Type **strsst** on the Main menu command line, and then press Enter.
 - c. Type your service tools user ID and service tools password on the Start Service Tools Sign On display, and then press Enter.

Remember: The service tools password is case-sensitive.

- d. Select **Start a service tool** on the System Service Tools display, and then press Enter.
 - e. Select **Hardware service manager** on the Start a Service Tool display, and then press Enter.
 - f. Press **F6** (print the configuration) from the Hardware Service Manager display.
 - g. To return to the Main Menu display, press **F3** (Exit) twice, and then press Enter.
 - h. Place the configuration list where you can refer to it in the future.
22. If you are a service provider and completed this task, return to the procedure that sent you here.
23. Complete the following steps for hot spare:
- a. Select **Work with hot spare protection** from the **Work with disk configuration** menu.
 - b. Select **Start device parity protection - RAID 5 with hot spare** or **Start device parity protection - RAID 6 with hot spare** depending on the level of parity protection that is wanted.

Configuring a disk drive or solid-state drive on a load source adapter for hot-spare protection by using the IBM i operating system

Learn how to configure a disk drive or solid-state drive on a load source adapter for hot-spare protection by using the IBM i operating system.

To start hot-spare protection on your load source adapter, you must determine the status of the drive in the load source slot and configure or exchange that drive. This action might require you to turn off the power to the system.

To configure a disk drive or solid-state drive on a load source adapter for hot-spare protection, complete the following steps:

1. If necessary, start the System Service Tools (SST) by typing **strsst** on the command line of the IBM i session, and then press Enter.
2. Type your service tools user ID and service tools password on the Start Service Tools (STRSST) Sign On display, and then press Enter.

Note: The service tools password is case-sensitive.

3. Determine the protection status of all disks that are controlled by the load source adapter. Do all drives that are a member of a parity sets or mirror sets have a status of active?

- **Yes:** Continue to the next step.
 - **No:** Replace the drive. Refer to the removing and replacing instructions for your system with the power turned on in IBM i.
4. Before completing the next step, consider the following information:

Restriction: There must be a drive of the same or larger capacity to act as a hot-spare function for the active load source drive.
 5. Determine whether a non-configured drive of the same or larger capacity is in a load source capable slot but is not the active load source. Only parallel SCSI places a restriction on the location of the load source. Any SAS, Fibre Channel, or virtual drive does not have this restriction.
 - **No:** There is no non-configured drive in a load source capable slot. Continue with the next step
 - **Yes:** A non-configured drive is in a load source capable slot. Return to the procedure that sent you here, and continue with the next step of that procedure.
 6. Choose the drive to be installed or exchanged with the drive in the load source slot by completing the following steps:
 - a. Select a drive in a parity set in a load source capable slot, but is not the active load source drive, and record the location of this drive.
 - b. Select a non-configured drive of the same or larger capacity from either a non-load source slot or a failed drive you are replacing with a non-configured drive.
 7. Stop the system or logical partition. For instructions, see “Stopping a system or logical partition” on page 84.
 8. Exchange the drives from the two locations you recorded in step 6 by removing both drives and placing them into the other drives slot.
 9. Start the system or logical partition. For instructions, see “Starting the system or logical partition” on page 86.
 10. Return to the procedure that sent you here.

Configuring a disk drive or solid-state drive for use in an Linux system or Linux logical partition

Configure the newly installed disk drive or solid-state drive (SSD) for your environment.

If the drive is attached to a PCI-X SCSI RAID controller, see the *PCI-X SCSI RAID Controller Reference Guide for Linux* in the IBM Knowledge Center - Linux information for IBM systems website (http://www-01.ibm.com/support/knowledgecenter/8247-22L/p8ebk/p8ebk_kickoff.htm).

Determining the disk drive or solid-state drive protection status in the IBM i operating system

Find information about determining the protection status of the drives in an IBM i system or IBM i logical partition.

To determine the protection status of the drives in an IBM i operating system, complete the following steps from the System Service Tools display:

Attention: If you do not know the protection status of the drives and you cannot get to the System Service Tools (SST) display, contact your next level of support.

1. Sign on **with at least service level authority**.
2. Type `strsst` on the command line of the IBM i session, and then press Enter.
3. Type your service tools user ID and service tools password on the Start Service Tools (STRSST) Sign On display, and then press Enter.

Note: The service tools password is case-sensitive.

4. Select **Work with disk units** from the System Service Tools (SST) display, and then press Enter.
5. Select **Display Disk Configuration** from the Work with Disk Units display, and then press Enter.
6. Select **Display Disk Configuration Status** from the Display Disk Configuration display, and then press Enter.

A list of each auxiliary storage pool (ASP) displays, showing the drives that are members of the ASP. The **Status** column shows one of the following protection statuses for the ASP:

- **Mirrored.** These ASPs are configured for mirrored protection. If the failing drive has mirrored protection, record the status of both drives in the mirrored pair. You need this information in the recovery procedure.
- **Unprotected.** An ASP with a status of Unprotected might contain drives that are device parity protected. Record the status of the failing drive as it is shown in the **Status** column of the Display Disk Configuration Status display.

A drive with one of the following statuses has device parity protection only if all other drives in the array are operational:

- DPY/Active
- DPY/Failed
- DPY/HDW Failure
- DPY/Degraded
- DPY/Power Loss
- DPY/Not Ready
- DPY/Unknown

A drive with any other status (such as DPY/Rebuild or DPY/Unprotected) does not have device parity protection.

Examples:

- Suppose one drive has a status of DPY/Failed while all other drives have a status of DPY/Unprotected. In this case, only the drive with the DPY/Failed status is protected. Servicing the failed drive does not result in data loss. Removing any of the unprotected drives might result in data loss.
- All drives have a status of DPY/Active or DPY/Degraded, therefore, all drives are protected. In this case, exchanging any drive does not result in data loss.

Tip: For more information about the meaning of a status for any drive, use the **Help** key on the display.

Rebuilding data on a replacement disk drive or solid-state drive

Find information about rebuilding data on a replacement disk drive or solid-state drive by using your operating system.

Rebuilding data on a replacement disk drive or solid-state drive in a system or logical partition running the AIX operating system

To rebuild data on the replacement disk drive or solid-state drive, refer to the information for the controller to which the drive is attached.

To rebuild data on the replacement disk drive or solid-state drive, see Replacing a disk in a SAS RAID adapter.

Rebuilding data on a replacement disk drive or solid-state drive in a system or logical partition running the IBM i operating system

Learn how to rebuild data on replacement disks.

To rebuild data on the replacement drive, complete the following steps:

1. If necessary, start System Service Tools (SST) by typing `strsst` on the command line of the IBM i session and pressing Enter.
2. Type your service tools user ID and service tools password on the Start Service Tools (STRSST) Sign On display. Press Enter.

Note: The service tools password is case sensitive.

3. Select **Work with disk units** from the Start System Service Tools (SST) display. Press Enter.
4. Select **Work with disk unit recovery** from the Work with Disk Units display. Press Enter.
5. If you determined that the drive you replaced had **device parity protection (RAID)**, follow these steps to restore device parity protection (RAID) on the drive:
 - a. Select **Rebuild disk unit data** on the Work with Disk unit recovery display. Press Enter.
 - b. Select 1 to rebuild the drive displayed (the drive displayed is the drive that you **removed**) on the Rebuild Disk Unit Data display. Press Enter.
 - c. Press Enter on the Confirm Rebuild Disk Unit Data display. The rebuild process might take several minutes to complete.
 - d. Press **F5** to refresh the display until the **Percent complete** shows 5%.
 - e. When the display shows at least 5% complete, you can either continue to monitor this display to completion, or press **F3 (Exit)** to return to the Work with disk units display.
 - f. Press **F3 (Exit)** to return to the System service tools display.
 - g. Press **F3 (Exit)** to return to the Exit SST display and press Enter.
 - h. Return to the procedure that sent you here.
6. If the drive that you replaced had **mirrored protection**, follow these steps:
 - a. Select **Replace configured unit** on the Work with Disk unit recovery display. Press Enter.
 - b. Select the configured drive that you are exchanging (suspended drive) on the Select Configured Unit to Replace display. Press Enter.
 - c. Select the drive that you just installed on the Select Replacement Unit display. This drive has a non-configured status.

Note: In some cases, it might take several minutes for a new drive to display. Repeat these steps until the new drive is shown.
Press Enter.

- d. Press Enter on the Confirm Replace of Configured Unit display to confirm your choice for replacement.
The replacement process might take several minutes to complete. When the process is complete, the Work with Disk unit recovery display is shown.
- e. Press **F3 (Exit)** to return to the Work with disk units display.
- f. Select **Display disk configuration** on the Work with disk units display.
- g. Select **Display disk configuration status** on the Display Disk Configuration display.
Mirrored status shows Resuming. When complete, the mirrored status shows Active. This process might take several minutes to complete. You can either monitor this display to completion, or press **F3 (Exit)** three times, and then press Enter to return to the IBM i main menu.

Rebuilding data on a replacement disk drive or solid-state drive in a system or logical partition that is running the Linux operating system

You can rebuild data on the replacement drive that was replaced because of a failed disk drive or solid-state drive or as a new installation.

If a hot-spare drive was available and protected the disk array throughout the drive failure, you can configure the newly installed drive as a hot spare. For SAS RAID controller information, see SAS RAID controllers for Linux (http://www.ibm.com/support/knowledgecenter/POWER8/p8ebk/p8ebk_kickoff.htm).

If a hot-spare rebuild was not initiated by the controller, you need to initiate a rebuild on the newly installed drive. To initiate the rebuild, follow these steps:

For an unprotected disk drive

If the drive you are replacing is in a RAID Level 0 disk array or in a failed RAID Level 5 or RAID Level 10 disk array, complete these tasks:

1. Re-create the disk array.
2. Re-create the file systems on the disk array.
3. Copy the data back to the restored disk array from your backup media.

Rebuilding data by using the `iprconfig` command:

If a hot-spare rebuild was not initiated by the controller, you must initiate a rebuild on the newly installed drive. To initiate the rebuild, complete the following procedure by using the `iprconfig` command.

For a disk drive in a RAID Level 5 or RAID Level 10 disk array

1. Log in as root user.
2. Type `iprconfig` on the command line of the Linux session and press Enter. The IBM Power RAID Configuration Utility display is shown.
3. Select **Work with disk unit recovery** from the IBM Power RAID Configuration Utility display. Press Enter. The Work with Disk Unit Recovery display is shown.
4. From the Work with Disk Unit Recovery display, select **Rebuild disk unit data**. A Rebuild Disk Unit Data display similar to the following example is shown.

```
Rebuild Disk Unit Data

Select the disks to be rebuilt

Type choice, press Enter.
 1=Rebuild

OPT Name  PCI/SCSI Location      Description      Status
-----
 1         0000:58:01.0.0/0:4:0      RAID Array Member  Failed

e=Exit   q=Cancel  t=Toggle
```

Figure 49. Example Rebuild Disk Unit Data display

5. Type 1 (Rebuild) next to the disk drive you want to rebuild and press Enter.

Note: Completing a rebuild on a drive overwrites the data currently on the drive. A Confirm Rebuild Disk Unit Data display similar to the following example is shown.

```
Confirm Rebuild Disk Unit Data

Rebuilding the disk unit data might take several minutes for each disk
selected.

Press Enter to confirm having the data rebuilt.
q=Cancel to return and change your choice.

OPT Name  PCI/SCSI Location      Description      Status
-----
1         0000:58:01.0.0/0:4:0        RAID Array Member  Failed

q=Cancel  t=Toggle
```

Figure 50. Example Confirm Rebuild Disk Unit Data display

6. To confirm that you want to rebuild the data on the drive, press Enter. The message that the rebuild started is shown at the bottom of the Work with Disk Unit Recovery display. The rebuild process might take several minutes to complete.

Common procedures for installing, removing and replacing disk drives or solid-state drives

Find procedures that are common for installing, removing, and replacing disk drives or solid-state drives.

Before you begin

Observe these precautions when you are installing, removing, or replacing features and parts.

These precautions are intended to create a safe environment to service your system and do not provide steps for servicing your system. The installation, removal, and replacement procedures provide the step-by-step processes required to service your system.

DANGER: When working on or around the system, observe the following precautions:

Electrical voltage and current from power, telephone, and communication cables are hazardous. To avoid a shock hazard:

- If IBM supplied the power cord(s), connect power to this unit only with the IBM provided power cord. Do not use the IBM provided power cord for any other product.
- Do not open or service any power supply assembly.
- Do not connect or disconnect any cables or perform installation, maintenance, or reconfiguration of this product during an electrical storm.
- The product might be equipped with multiple power cords. To remove all hazardous voltages, disconnect all power cords.
 - For AC power, disconnect all power cords from their AC power source.
 - For racks with a DC power distribution panel (PDP), disconnect the customer's DC power source to the PDP.
- When connecting power to the product ensure all power cables are properly connected.
 - For racks with AC power, connect all power cords to a properly wired and grounded electrical outlet. Ensure that the outlet supplies proper voltage and phase rotation according to the system rating plate.
 - For racks with a DC power distribution panel (PDP), connect the customer's DC power source to the PDP. Ensure that the proper polarity is used when attaching the DC power and DC power return wiring.
- Connect any equipment that will be attached to this product to properly wired outlets.
- When possible, use one hand only to connect or disconnect signal cables.
- Never turn on any equipment when there is evidence of fire, water, or structural damage.
- Do not attempt to switch on power to the machine until all possible unsafe conditions are corrected.
- Assume that an electrical safety hazard is present. Perform all continuity, grounding, and power checks specified during the subsystem installation procedures to ensure that the machine meets safety requirements.
- Do not continue with the inspection if any unsafe conditions are present.
- Before you open the device covers, unless instructed otherwise in the installation and configuration procedures: Disconnect the attached AC power cords, turn off the applicable circuit breakers located in the rack power distribution panel (PDP), and disconnect any telecommunications systems, networks, and modems.

DANGER:

- Connect and disconnect cables as described in the following procedures when installing, moving, or opening covers on this product or attached devices.

To Disconnect:

1. Turn off everything (unless instructed otherwise).

2. For AC power, remove the power cords from the outlets.
3. For racks with a DC power distribution panel (PDP), turn off the circuit breakers located in the PDP and remove the power from the Customer's DC power source.
4. Remove the signal cables from the connectors.
5. Remove all cables from the devices.

To Connect:

1. Turn off everything (unless instructed otherwise).
2. Attach all cables to the devices.
3. Attach the signal cables to the connectors.
4. For AC power, attach the power cords to the outlets.
5. For racks with a DC power distribution panel (PDP), restore the power from the Customer's DC power source and turn on the circuit breakers located in the PDP.
6. Turn on the devices.

Sharp edges, corners and joints may be present in and around the system. Use care when handling equipment to avoid cuts, scrapes and pinching. (D005)

(R001 part 1 of 2):

DANGER: Observe the following precautions when working on or around your IT rack system:

- Heavy equipment—personal injury or equipment damage might result if mishandled.
- Always lower the leveling pads on the rack cabinet.
- Always install stabilizer brackets on the rack cabinet.
- To avoid hazardous conditions due to uneven mechanical loading, always install the heaviest devices in the bottom of the rack cabinet. Always install servers and optional devices starting from the bottom of the rack cabinet.
- Rack-mounted devices are not to be used as shelves or work spaces. Do not place objects on top of rack-mounted devices. In addition, do not lean on rack mounted devices and do not use them to stabilize your body position (for example, when working from a ladder).



- Each rack cabinet might have more than one power cord.
 - For AC powered racks, be sure to disconnect all power cords in the rack cabinet when directed to disconnect power during servicing.
 - For racks with a DC power distribution panel (PDP), turn off the circuit breaker that controls the power to the system unit(s), or disconnect the customer's DC power source, when directed to disconnect power during servicing.
- Connect all devices installed in a rack cabinet to power devices installed in the same rack cabinet. Do not plug a power cord from a device installed in one rack cabinet into a power device installed in a different rack cabinet.
- An electrical outlet that is not correctly wired could place hazardous voltage on the metal parts of the system or the devices that attach to the system. It is the responsibility of the customer to ensure that the outlet is correctly wired and grounded to prevent an electrical shock.

(R001 part 2 of 2):

CAUTION:

- Do not install a unit in a rack where the internal rack ambient temperatures will exceed the manufacturer's recommended ambient temperature for all your rack-mounted devices.
- Do not install a unit in a rack where the air flow is compromised. Ensure that air flow is not blocked or reduced on any side, front, or back of a unit used for air flow through the unit.

- Consideration should be given to the connection of the equipment to the supply circuit so that overloading of the circuits does not compromise the supply wiring or overcurrent protection. To provide the correct power connection to a rack, refer to the rating labels located on the equipment in the rack to determine the total power requirement of the supply circuit.
- (For sliding drawers.) Do not pull out or install any drawer or feature if the rack stabilizer brackets are not attached to the rack. Do not pull out more than one drawer at a time. The rack might become unstable if you pull out more than one drawer at a time.



- (For fixed drawers.) This drawer is a fixed drawer and must not be moved for servicing unless specified by the manufacturer. Attempting to move the drawer partially or completely out of the rack might cause the rack to become unstable or cause the drawer to fall out of the rack.

Before you begin a replacement or installation procedure, perform these tasks:

1. If you are installing a new feature, ensure that you have the software required to support the new feature. See IBM Prerequisite.
2. If you are performing an installation or replacement procedure that might put your data at risk, ensure, wherever possible, that you have a current backup of your system or logical partition (including operating systems, licensed programs, and data).
3. Review the installation or replacement procedure for the feature or part.
4. Note the significance of color on your system.

Blue or terra-cotta on a part of the hardware indicates a touch point where you can grip the hardware to remove it from or install it in the system, open or close a latch, and so on. Terra-cotta might also indicate that the part can be removed and replaced with the system or logical partition power on.

5. Ensure that you have access to a medium flat-blade screwdriver, a Phillips screwdriver, and a pair of scissors.
6. If parts are incorrect, missing, or visibly damaged, do the following:
 - If you are replacing a part, contact the provider of your parts or next level of support.
 - If you are installing a feature, contact one of the following service organizations:
 - The provider of your parts or next level of support.
 - In the United States, the IBM Rochester Manufacturing Automated Information Line (R-MAIL) at 1-800-300-8751.

In countries and regions outside of the United States, use the following website to locate your service and support telephone numbers:

<http://www.ibm.com/planetwide>

7. If you encounter difficulties during the installation, contact your service provider, your IBM reseller, or your next level of support.
8. If you are installing new hardware in a logical partition, you need to understand and plan for the implications of partitioning your system. For information, see Logical Partitioning.

Identifying a part

Learn how to identify the system or enclosure that contains a failing part, the location code and light-emitting diode (LED) status for a part, and how to activate and deactivate the identify part LED.

Note: If you are using PowerKVM, you must use the ASMI procedures to identify a part or enclosure.

Table 6. Tasks to identify a part

What you want to do	See the following information
Determine which server or enclosure contains the part	"Identifying the enclosure or server that contains the part"
Find the location of the part and determine whether the part has an identifying LED	"Finding the part location code and LED support status" on page 78
Turn on an identifying LED for a part	
If you are using PowerKVM:	"Identifying a part by using the ASMI" on page 82
If your system is in the runtime state:	"Identifying a part by using the operating system or VIOS" on page 79
If your system is in the standby power state:	"Identifying a part by using the ASMI" on page 82
If you have an HMC:	"Identifying a part by using the HMC" on page 83
Turn off an identify LED	"Deactivating an identify LED" on page 105
Turn off a check log indicator	"Deactivating a check log indicator (system information indicator) by using the ASMI" on page 108

Identifying the enclosure or server that contains the part

Learn how to determine which server or enclosure has the part you want to replace.

Enabling enclosure or server indicators with the ASMI

Find out how to enable enclosure or server indicators by using the Advanced System Management Interface (ASMI).

To perform this operation, you must have one of the following authority levels:

- Administrator
- Authorized service provider

To enable the enclosure or server indicator states, complete the following steps:

1. On the ASMI Welcome pane, specify your user ID and password, and click **Log In**.
2. In the navigation area, expand **System Configuration > Service Indicators > Enclosure Indicators**. A list of enclosures is displayed.
3. Select the enclosure and click **Continue**. A list of location codes is displayed. Alternatively, you can click **Indicators by Location Code** and type the location code in the **Location code** field.
4. In the **Identify indicator status** field, select **Identify**.
5. To save the changes made to the state of an indicator, click **Save settings**.

Control panel LEDs

Use this information as a guide to the control panel LEDs and buttons.

Use Figure 51 on page 77 with the control panel LED descriptions to understand the system status that is indicated by the control panel.

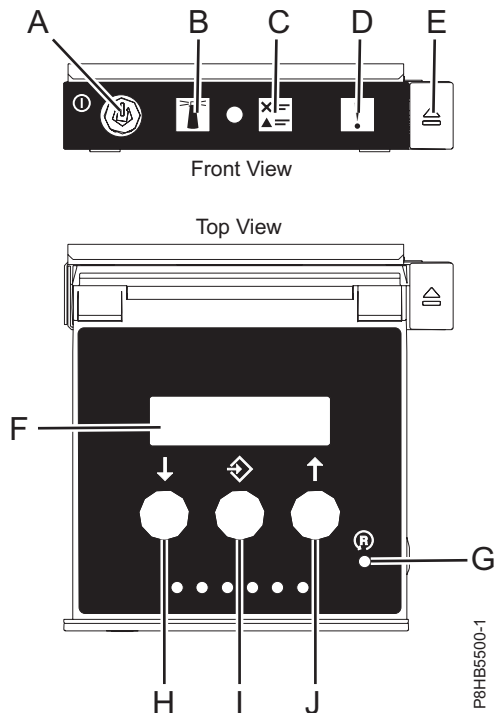

Figure 51. Control panel LEDs

Control panel LEDs and descriptions:

- **A:** Power-on button
 - A constant light indicates full system power to the unit.
 - A flashing light indicates standby power to the unit.
 - There is approximately a 30-second transition period from the time the power-on button is pressed to when the power LED goes from flashing to solid. During the transition period, the LED might flash faster.
- **B:** Enclosure identify light
 - A constant light indicates the identify state, which is used to identify a part.
 - No light indicates that the system is operating normally.
- **C:** Check log light
 - No light indicates that the system is operating normally.
 - Light on indicates that the system requires attention.
- **D:** Enclosure fault light
 - A constant light indicates a fault in the system unit.
 - No light indicates that the system is operating normally.
- **E:** Eject button
- **F:** Function/Data display
- **G:** Pinhole reset button
- **H:** Decrement button
- **I:** Enter button
- **J:** Increment button

Activating an identify LED for an enclosure or server by using the HMC

Learn how to activate an identify LED for an enclosure or server by using the Hardware Management Console (HMC).

The system provides several LEDs that help identify various components in the system, such as enclosures or field-replaceable units (FRUs). For this reason, they are called *identify LEDs*.

If you want to add a part to a specific enclosure or server, you need to know the machine type, model, and serial number (MTMS) of the enclosure or server. To determine whether you have the correct MTMS for the enclosure or server that needs the new part, you can activate the LED for an enclosure or server and verify that the MTMS corresponds to the enclosure or server that requires the new part.

1. Choose one of the following navigation options depending on the interface type of the HMC:
 - If you are using an HMC Classic or HMC Enhanced interface, complete the following steps:
 - a. In the navigation area, click **Systems Management > Servers**.
 - b. In the content pane, select the server.
 - c. Click **Tasks > Operations > LED Status > Identify LED**. The Identify LED, Select Enclosure window is displayed.
 - If you are using an HMC Enhanced + Tech Preview (Pre-GA) or HMC Enhanced+ interface, complete the following steps:



- a. In the navigation area, click the **Resources** icon  , and then click **All Systems**.
 - b. Click the server name for which you want to activate the identify LED.
 - c. Click **System Actions > Attention LED > Identify Attention LED**. The Identify Attention LED, Select Enclosure window is displayed.
2. To activate an identify LED for an enclosure or server, select an enclosure or server and then click **Activate LED**. The associated LED is turned on.

Finding the part location code and LED support status

You can use location codes for the server you are working with to find the part location code and whether there is Identify LED support.

To find the location code and to determine if there is identify LED support, complete the following steps:

1. Select the server you are working on to see the location codes:
 - 5148-21L, 5148-22L, 8247-21L, 8247-22L, 8284-21A, or 8284-22A locations (http://www.ibm.com/support/knowledgecenter/POWER8/p8ecs/p8ecs_83x_8rx_loccodes.htm)
 - 8247-42L, 8286-41A, or 8286-42A locations (http://www.ibm.com/support/knowledgecenter/POWER8/p8ecs/p8ecs_82x_84x_loccodes.htm)
 - 8408-44E or 8408-E8E locations(http://www.ibm.com/support/knowledgecenter/POWER8/p8ecs/p8ecs_85x_loccodes.htm)
 - 9080-MHE, 9080-MME, 9119-MHE, or 9119-MME locations(http://www.ibm.com/support/knowledgecenter/POWER8/p8ecs/p8ecs_87x_88x_loccodes.htm)
2. Record the location code.
3. Refer to the field replaceable unit (FRU) location table, Identify LED column to see if the word **Yes** (there is an identify LED) or **No** (there is not an identify LED) appears.
4. Select from the following options:
 - If the part has an identify LED, refer to the applicable procedure:
 - If you are using IBM PowerKVM, see “Identifying a part by using the ASMI” on page 82.
 - If your system is at runtime state, see “Identifying a part by using the operating system or VIOS” on page 79.
 - If your system is at standby power state, see “Identifying a part by using the ASMI” on page 82.
 - If the part does not have an identify LED, see Identifying the enclosure or server that contains the part.

Identifying a part by using the operating system or VIOS

Learn how to use AIX, IBM i, Linux, or the Virtual I/O Server (VIOS) to identify a part.

For IBM Power Systems that contain the POWER8 processor, the identify LEDs can be used to identify or verify the location of a part that you intend to install, remove, or replace. The identify function (flashing the amber LED) corresponds to the location code you are going to work with.

When you are removing a part, first verify whether you are working on the correct part by using the identify function in the management console or other user interface. When you remove a part by using the Hardware Management Console (HMC), the identify function is activated and deactivated automatically at the correct times.

The identify function causes the amber LED to flash. When you turn off the identify function, the LED returns to the state it was previously. For parts that have a blue service button, the identify function sets LED information for the service button so that when the button is pressed, the correct LEDs on that part flash.

Note: Use the enclosure locate LED to identify the enclosure that is being serviced. Then, confirm and verify the location of the FRU (to be serviced) in the enclosure by checking the active identify indicator (flashing LED) for the selected FRU. For some FRUs, you might need to remove the service access cover to be able to see the identify indicators.

Identifying a part in an AIX system or logical partition

Use these instructions to learn how to locate a part, activate the indicator light for the part, and deactivate the indicator light for the part on a system or logical partition running the AIX operating system.

Finding the location code for a part in an AIX system or logical partition:

You might need to use AIX tools, before activating the indicator light, to locate a part.

To configure the AIX system to locate a part, complete the following steps:

1. Log in as root user or celogin-.
2. At the command line, type `diag` and press Enter.
3. From the Function Selection menu, select **Task Selection** and press Enter.
4. Select **Display Previous Diagnostic Results** and press Enter.
5. From the Display Previous Diagnostic Results display, select **Display Diagnostic Log Summary**. The Display Diagnostic Log display shows a chronological list of events.
6. Look in the **T** column for the most recent **S** entry. Select this row in the table and press Enter.
7. Select **Commit**. The details of this log entry are shown.
8. Record the location information and the SRN value that is shown near the end of the entry.
9. Exit to the command line.

Use the location information for the part to activate the indicator light that identifies the part. See “Activating the indicator light for a part by using AIX diagnostics.”

Activating the indicator light for a part by using AIX diagnostics:

Use these instructions to help physically identify the location of a part you are servicing.

To activate the indicator light for a part, complete the following steps:

1. Log in as root user.
2. At the command line, type `diag` and press Enter.

3. From the **Function Selection** menu, select **Task Selection** and press Enter.
4. From the **Task Selection** menu, select **Identify and Attention Indicators** and press Enter.
5. From the list of lights, select the location code for the part and press Enter.
6. Select **Commit**. This turns on the system attention and indicator light for the part.

Important: A flashing amber LED indicates the location of the part and a solid amber LED indicates that the part is failing.

7. Exit to the command line.

Identifying a part in an IBM i system or logical partition

You can activate or deactivate the indicator light to locate a part in an IBM i system or logical partition.

Finding the location code and activating the indicator light for a part by using the IBM i operating system:

You can search the service action log for an entry that matches the time, reference code, or resource of a problem, and then activate the indicator light for a part.

1. Sign on to an IBM i session, **with at least service level authority**.
2. On the command line of the session, type `strsst` and press Enter.

Note: If you cannot get to the System Service Tools (SST) display, use function 21 from the control panel. Alternatively, if the system is managed by a Hardware Management Console (HMC), use the Service Focal Point utilities to get to the Dedicated Service Tools (DST) display.

3. Type your service tools user ID and service tools password on the System Service Tools (SST) Sign On display and press Enter.

Remember: The service tools password is case sensitive.

4. Select **Start a service tool** from the System Service Tools (SST) display and press Enter.
5. Select **Hardware service manager** from the Start a Service Tool display and press Enter.
6. Select **Work with service action log** from the Hardware Service Manager display and press Enter.
7. On the Select Timeframe display, change the **From: Date and Time** field to a date and time prior to when the problem occurred.
8. Search for an entry that matches one or more conditions of the problem:
 - System reference code
 - Resource
 - Date and time
 - Failing item list
9. Select option 2 (Display failing item information) to display the service action log entry.
10. Select option 2 (Display details) to display location information for the failing part to be replaced. The information displayed in the date and time fields is the date and time for the first occurrence of the specific system reference code for the resource displayed during the time range selected.
11. If location information is available, select option 6 (Indicator on) to turn on the indicator light for the part.

Tip: If the part does not contain a physical indicator light, a higher-level indicator light is activated. For example, the indicator light for the backplane or unit that contains the part might be lit. In this case, use the location information to locate the actual part.

12. Look for the enclosure indicator light to locate the enclosure that contains the part.

Important: A flashing amber LED indicates the location of the part and a solid amber LED indicates that the part is failing.

Identifying a part in a Linux system or logical partition

If the service aids have been installed on a system or logical partition, you can activate or deactivate the indicator lights to locate a part or complete a service action.

Finding the location code of a part in a Linux system or logical partition:

Use this procedure to retrieve the location code of the part to perform service operations.

To find the location code of a part in a Linux system or logical partition, complete the following steps:

1. Log in as root user.
2. At the command line, type `grep diagela /var/log/platform` and press Enter.
3. Look for the most recent entry that contains a system reference code (SRC).
4. Record the location information.

Related information:

 Service and productivity tools for PowerLinux servers from IBM
IBM provides hardware diagnostic aids and productivity tools, and installation aids for Linux operating systems on IBM Power Systems servers.

Activating the indicator light for a part by using the Linux operating system:

If you know the location code of a part, activate the indicator light to help locate the part the while performing service operations.

To activate the indicator light, complete the following steps:

1. Log in as root user.
2. At the command line, type `/usr/sbin/usysident -s identify -l location_code` and press Enter.
3. Look for the system attention light to identify the enclosure that contains the part.

Important: A flashing amber LED indicates the location of the part and a solid amber LED indicates that the part is failing.

Related information:

 Service and productivity tools for Linux on Power servers
IBM provides hardware diagnostic aids and productivity tools, and installation aids for Linux operating systems on IBM Power Systems servers.

Identifying a part in a VIOS system or logical partition

Learn how to find the location code and identify a part by using the Virtual I/O Server (VIOS) tools.

Finding the location code of a part in a VIOS system or logical partition:

You can use Virtual I/O Server (VIOS) tools to find the location code of a part before you activate the indicator light.

To configure the Virtual I/O Server system for identifying a part, complete the following steps:

1. Log in as root user or `celogin-`.
2. At the command line, type `diagmenu` and press Enter.
3. From the **Function Selection** menu, select **Task Selection** and press Enter.
4. Select **Display Previous Diagnostic Results** and press Enter.
5. From the **Display Previous Diagnostic Results** display, select **Display Diagnostic Log Summary**. A **Display Diagnostic Log** display appears. This display contains a chronological list of events.
6. Look in the **T** column for the most recent **S** entry. Select this row in the table and press Enter.

7. Choose **Commit**. The details of this log entry are shown.
8. Record the location information and the SRN value shown near the end of the entry.
9. Exit to the command line.

Use the location information for the part to activate the indicator light that identifies the part. For instructions, see “Activating the indicator light for a part by using the VIOS tools.”

Activating the indicator light for a part by using the VIOS tools:

You can use Virtual I/O Server (VIOS) tools to activate the indicator light to physically locate a part.

To turn on the indicator light for identifying a part, complete the following steps:

1. Log in as root user.
2. At the command line, type `diagmenu` and press Enter.
3. From the **Function Selection** menu, select **Task Selection** and press Enter.
4. From the **Task Selection** menu, select **Identify and Attention Indicators** and press Enter.
5. From the list of lights, select the location code for the failing part and press Enter.
6. Select **Commit**. This turns on the system attention and indicator light for the part.

Important: A flashing amber LED indicates the location of the part and a solid amber LED indicates that the part is failing.

7. Exit to the command line.

Identifying a part by using the ASMI

Learn how to activate or deactivate amber identify indicator light-emitting diodes (LEDs) by using the Advanced System Management Interface (ASMI).

You can access the ASMI by using a web browser. For more information, see [Accessing the Advanced System Management Interface by using a web browser \(http://www.ibm.com/support/knowledgecenter/POWER8/p8ect/pxect_browser.htm\)](http://www.ibm.com/support/knowledgecenter/POWER8/p8ect/pxect_browser.htm).

For IBM Power Systems that contain the POWER8 processor, the identify LEDs can be used to identify or verify the location of a part that you intend to install, remove, or replace. The identify function (flashing the amber LED) corresponds to the location code you are going to work with.

You can set the identify LED to flash and to stop flashing by using the ASMI.

Note: You can use the ASMI to turn on and turn off the identify indicators except for the adapters, disk drives, solid-state drives, and media devices.

Activating the identify LED by using the ASMI when you know the location code

Learn how to activate the identify LED by using the Advanced System Management Interface (ASMI) when you know the location code.

You can specify the location code of any indicator to view or modify its current state. If you provide the wrong location code, the ASMI attempts to go to the next higher level of the location code.

The next level is the base-level location code for that field replaceable unit (FRU). For example, a user types the location code for the FRU located on the second memory module slot of the third enclosure in the system. If the location code for the second memory module slot is incorrect (the FRU does not exist at this location), an attempt to set the indicator for the third enclosure is initiated. This process continues until a FRU is located or no other level is available.

To complete this operation, your authority level must be one of the following levels:

- Administrator
- Authorized service provider

To change the current state of an indicator, complete the following steps:

1. On the ASMI Welcome pane, specify your user ID and password, and click **Log In**.
2. In the navigation area, expand **System Configuration > Service Indicators > Indicators by Location code**.
3. In the **Location code** field, type the location code of the FRU and click **Continue**.
4. From the **Identify indicator status** list, select **Identify**.
5. Click **Save settings**.

Activating the identify LED by using the ASMI when you do not know the location code

Learn how to activate the identify LED by using the Advanced System Management Interface (ASMI) when you do not know the location code.

You can turn on the identify indicators in each enclosure.

To complete this operation, your authority level must be one of the following levels:

- Administrator
- Authorized service provider

To enable the enclosure indicator states, complete the following steps:

1. On the ASMI Welcome pane, specify your user ID and password, and click **Log In**.
2. In the navigation area, expand **System Configuration > Service Indicators > Enclosure Indicators**. All servers and enclosures managed by the ASMI will display.
3. Select the server or enclosure with the part that needs to be replaced and click **Continue**. The location code identifiers are listed.
4. Select the location code identifier and select **Identify**.
5. To save the changes made to the state of one or more FRU indicators, click **Save settings**.

Identifying a part by using the HMC

You can use the following procedures to activate light-emitting diodes (LEDs) by using the Hardware Management Console (HMC).

You can use the identify LED for a FRU associated with a specified enclosure to help you identify a part. For example, if you want to hook up a cable to a specific I/O adapter, you can activate the LED for the adapter, which is a field replaceable unit (FRU). Then, you can physically check to see where you should hook up the cable. This action is especially useful when you have several adapters with open ports.

1. Choose one of the following navigation options depending on the interface type of the HMC:
 - If you are using an HMC Classic or HMC Enhanced interface, complete the following steps:
 - a. In the navigation area, click **Systems Management > Servers**.
 - b. Select the server that you are working on.
 - c. In the **Tasks** menu, click **Operations > LED status > Identify LED**. The **Identify LED, Select Enclosure** window is displayed.
 - If you are using an HMC Enhanced + Tech Preview (Pre-GA) or HMC Enhanced+ interface, complete the following steps.



- a. In the navigation area, click the **Resources** icon  , and then click **All Systems**.
 - b. Click the system name for which you want to activate the attention LED.
 - c. In the navigation area, click **System Actions > Attention LED > Identify Attention LED**. The Identify LED, Select Enclosure window is displayed.
2. To activate an identify LED for the enclosure, select an enclosure and then click **Activate LED**. The associated LED is turned on and is flashing.
 3. To activate an identify LED for one or more FRUs in the enclosure, complete the following steps:
 - a. Select an enclosure and then click **List FRUs**.
 - b. Select the FRUs for which you want to activate the identify LED and click **Activate LED**. The associated LED is turned on and is flashing.

Stopping a system or logical partition

Learn how to stop a system or logical partition as a part of a system upgrade or service action.

Attention: Using either the power-on button on the control panel or entering commands at the Hardware Management Console (HMC) to stop the system can cause unpredictable results in the data files. Also, the next time you start the system, it might take longer if all applications are not ended before stopping the system.

To stop the system or logical partition, select the appropriate procedure.

Stopping a system that is not managed by an HMC

You might need to stop the system to complete another task. If your system is not managed by the Hardware Management Console (HMC), use these instructions to stop the system by using the power button or the Advanced System Management Interface (ASMI).

Before you stop the system, follow these steps:

1. Ensure that all jobs are completed and end all applications.
2. If a Virtual I/O Server (VIOS) logical partition is running, ensure that all clients are shut down or that the clients have access to their devices by using an alternative method.

Stopping a system by using the control panel

You might need to stop the system to complete another task. If your system is not managed by the Hardware Management Console (HMC), use these instructions to stop the system by using the power button.

The following procedure describes how to stop a system that is not managed by the HMC.

1. Log in to the host partition as a user with the authority to run the **shutdown** or **pwrdownsys** (Power Down System) command.
2. At the command line, enter one of the following commands:
 - If your system is running the AIX operating system, type **shutdown**.
 - If your system is running the Linux operating system, type **shutdown -h now**.
 - If your system is running the IBM i operating system, type **PWRDWNSYS**. If your system is partitioned, use the **PWRDWNSYS** command to power down each of the secondary partitions. Then, use the **PWRDWNSYS** command to power down the primary partition.

The command stops the operating system. The system power turns off, the power-on light begins to slowly flash, and the system goes into a standby state.

3. Record the IPL type and the IPL mode from the control panel display to help you return the system to this state when the installation or replacement procedure is completed.
4. Set the power switches of any devices that are connected to the system to off.

Stopping a system by using the ASMI

You might need to stop the system to complete another task. If your system is not managed by the Hardware Management Console (HMC), use these instructions to stop the system by using the Advanced System Management Interface (ASMI).

To stop a system by using the ASMI, complete the following steps:

1. On the ASMI Welcome pane, specify your user ID and password, and click **Log In**.
2. In the navigation area, click **Power/Restart Control > Power On/Off System**. The power state of the system is displayed.
3. Specify the settings as required and click **Save setting and power off**.

Stopping a system by using the HMC

You can use the Hardware Management Console (HMC) to stop the system or logical partition.

By default, the managed system is set to power off automatically when you shut down the last running logical partition on the managed system. If you set the managed system properties on the HMC so that the managed system does not power off automatically, you must use this procedure to power off your managed system.

Attention: Ensure that you shut down the running logical partitions on the managed system before you power off the managed system. Powering off the managed system without shutting down the logical partitions first causes the logical partitions to shut down abnormally and can cause data loss. If you use a Virtual I/O Server (VIOS) logical partition, ensure that all clients are shut down or that the clients have access to their devices by using an alternative method.

To power off a managed system, you must be a member of one of the following roles:

- Super administrator
- Service representative
- Operator
- Product engineer

Note: If you are a product engineer, verify that the customer has shut down all active partitions and has powered off the managed system. Continue with the procedure only after the status of the server changes to **Power Off**.

Stopping a system by using the HMC Classic or HMC Enhanced interface

Learn how to stop a system by using the HMC Classic or HMC Enhanced interface.

To stop the system or logical partition by using the HMC Classic or HMC Enhanced interface, complete the following steps:

1. In the navigation area, click **Systems Management > Servers**.
2. In the content pane, select the managed system.
3. In the Tasks area, click **Operations > Power Off**.
4. Select the appropriate power-off mode and click **OK**.

Related information:

 Shutting down and restarting logical partitions

Stopping a system by using the HMC Enhanced + Tech Preview (Pre-GA) or HMC Enhanced+ interface

Learn how to stop a system by using the HMC Enhanced + Tech Preview (Pre-GA) or HMC Enhanced+ interface.

To stop the system or logical partition by using the HMC Enhanced + Tech Preview (Pre-GA) or HMC Enhanced+ interface, complete the following steps:

1. You must deactivate all the active logical partitions before powering off the system. To deactivate logical partitions for a specific system, complete the following steps:



- a. In the navigation area, click the **Resources** icon , and then click **All Systems**.
 - b. Click the system name for which you want to deactivate partitions.
 - c. Select the logical partitions that you want to deactivate.
 - d. In the content pane, click **Actions > Deactivate**.
 - e. Click **OK**.
2. To power off the system, complete the following steps:



- a. In the navigation area, click the **Resources** icon , and then click **All Systems**.
- b. Select the system that you want to power off.
- c. In the content pane, click **Actions > View All Actions > Power Off**.
- d. Click **OK**.

Stopping an IBM PowerKVM system

You can use the Intelligent Platform Management Interface (IPMI) to stop an IBM PowerKVM system.

To stop an IBM PowerKVM system, complete the following steps:

1. Log in to the host as a root user or with sudo authority.
2. To power off each of the guests, complete the following steps.
 - a. To obtain a list of all guests, type **virsh list**.
 - b. For each guest in the list, type **virsh shutdown domain name** or type **virsh shutdown domain ID**.

Note:

Type **virsh list** to verify whether all the guests are powered off. If any guest is not powered off, type **virsh destroy domain name** or type **virsh destroy domain ID** to power off the guest.

3. Run the **ipmitool -I lanplus -H FSP IP -P ipmipassword chassis power off** command from a remote system.

Starting the system or logical partition

Learn how to start a system or logical partition after performing a service action or system upgrade.

Starting a system that is not managed by an HMC

You can use the power button or the Advanced System Management Interface (ASMI) to start a system that is not managed by a Hardware Management Console (HMC).

Starting a system by using the control panel

You can use the power button on the control panel to start a system that is not managed by a Hardware Management Console (HMC).

To start a system by using the control panel, complete the following steps:

1. Open the front rack door, if necessary.
2. Before you press the power button on the control panel, ensure that power is connected to the system unit as follows:
 - All system power cables are connected to a power source.
 - The power LED, as shown in the following figure, is slowly flashing.
 - The top of the display, as shown in the following figure, shows 01 V=F.
3. Press the power button (**A**), as shown in the following figure, on the control panel.

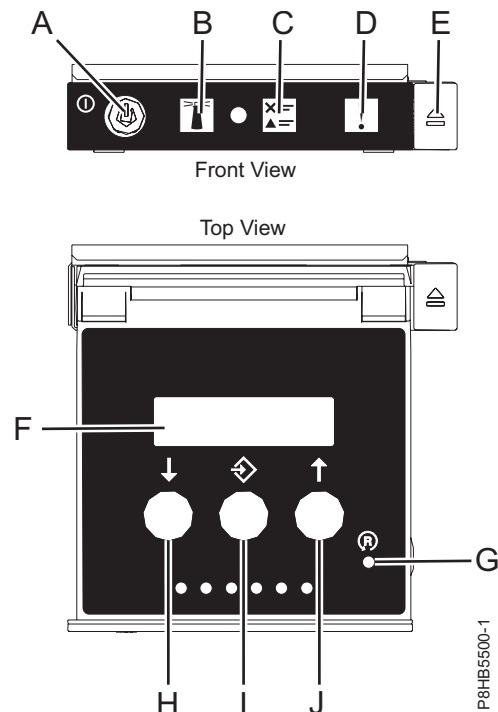

Figure 52. Control panel

- **A:** Power-on button
 - A constant light indicates full system power to the unit.
 - A flashing light indicates standby power to the unit.
 - There is approximately a 30-second transition period from the time the power-on button is pressed to when the power LED goes from flashing to solid. During the transition period, the LED might flash faster.
- **B:** Enclosure identify light
 - A constant light indicates the identify state, which is used to identify a part.
 - No light indicates that the system is operating normally.
- **C:** System information light
 - No light indicates that the system is operating normally.
 - Light on indicates that the system requires attention.
- **D:** Enclosure fault roll-up light

- A constant light indicates a fault in the enclosure.
 - No light indicates that the system is operating normally.
 - **E:** Eject button
 - **F:** Function/Data display
 - **G:** Pinhole reset button
 - **H:** Decrement button
 - **I:** Enter button
 - **J:** Increment button
4. Observe the following aspects after pressing the power button:
- The power-on light begins to flash faster.
 - The system cooling fans are activated after approximately 30 seconds and begin to accelerate to operating speed.
 - Progress indicators, also referred to as checkpoints, appear on the control panel display while the system is being started. The power-on light on the control panel stops flashing and remains on, indicating that the system power is on.

Tip: If pressing the power button does not start the system, then contact your next level of support or your service provider.

Starting a system by using the ASMI

You can use the Advanced System Management Interface (ASMI) to start a system that is not managed by a Hardware Management Console (HMC).

To start a system by using the ASMI, complete the following steps:

1. On the ASMI Welcome pane, specify your user ID and password, and click **Log In**.
2. In the navigation area, click **Power/Restart Control > Power On/Off System**. The power state of the system is displayed.
3. Specify the settings as required and click **Save setting and power on**.

Starting a system or logical partition by using the HMC

You can use the Hardware Management Console (HMC) to start the system or logical partition after the required cables are installed and the power cables are connected to a power source.

Starting a system or logical partition by using the HMC Classic or HMC Enhanced interface

Learn how to start a system or logical partition by using the HMC Classic or HMC Enhanced interface.

To start the system by using the HMC Classic or HMC Enhanced interface, complete the following steps:

1. Verify that the logical partition start policy is set to **User-Initiated** by completing the following steps:
 - a. In the navigation area, expand **Systems Management > Servers**.
 - b. In the content pane, select the managed system.
 - c. In the Tasks area, click **Properties**.
 - d. Click the **Power-On Parameters** tab. Ensure that the **Partition start policy** field is set to **User-Initiated**.
2. Power on the managed system by completing the following steps:
 - a. In the navigation area, expand **Systems Management > Servers**.
 - b. In the content pane, select the managed system.
 - c. Click **Operations > Power on**.
 - d. Select the power-on option and click **OK**.

Starting a system or logical partition by using the HMC Enhanced + Tech Preview (Pre-GA) or HMC Enhanced+ interface

Learn how to start a system or logical partition by using the HMC Enhanced + Tech Preview (Pre-GA) or HMC Enhanced+ interface.

To start a system or logical partition by using the HMC Enhanced + Tech Preview (Pre-GA) or HMC Enhanced+ interface, complete the following steps:

1. To power on the managed system, complete the following steps:



- a. In the navigation area, click the **Resources** icon  , and then click **All Systems**.
- b. Select the system that you want to power on.
- c. In the content pane, click **Actions > View All Actions > Power On**.
- d. Click **OK**.

2. To activate a logical partition, complete the following steps:



- a. In the navigation area, click the **Resources** icon  , and then click **All Partitions**.
- b. Click the logical partition name that you want to activate.
- c. In the navigation area, click **Partition Actions > Operations > Activate**.
- d. Click **OK**.

3. To activate a logical partition for a specific system, complete the following steps:



- a. In the navigation area, click the **Resources** icon  , and then click **All Systems**.
- b. Click the system name in which you want to activate the logical partition.
- c. Select logical partitions that you want to activate.
- d. In the content pane, click **Actions > Activate**.
- e. Click **OK**.

4. To verify that the logical partition start policy is set to **User-Initiated**, complete the following steps:



- a. In the navigation area, click the **Resources** icon  , and then click **All Systems**.
- b. Click the system name to view details.
- c. In the navigation area, click **Properties > Other Properties**.
- d. Click the **Power-On Parameters** tab. Ensure that the **Partition start policy** field is set to **User-Initiated**.

Starting an IBM PowerKVM system

You can use the Intelligent Platform Management Interface (IPMI) to start an IBM PowerKVM system.

To start an IBM PowerKVM system, run the `ipmitool -I lanplus -H FSP IP -P ipmipassword chassis power on` command from a remote system.

Installing or replacing a part with an HMC

You can use the Hardware Management Console (HMC) to perform many service actions, including the installation of a new field-replaceable unit (FRU) or parts.

Installing a part by using the HMC

You can use the Hardware Management Console (HMC) to perform many service actions, including the installation of a new feature or part.

To install a feature or part into a system or an expansion unit by using the HMC, complete the following steps:

1. Choose one of the following navigation options depending on the interface type of the Hardware Management Console (HMC):

- If you are using an HMC Classic or HMC Enhanced interface, complete the following steps:
 - a. In the navigation area, expand **Systems Management > Servers**.
 - b. Select the managed system for which you want to install a part.

Note: If your part is in a miscellaneous equipment specification (MES), continue with step 1c. If your part is contained in the install that is done by the system services representative (SSR) or in a ship group, go to step 1h.

- c. In the Tasks area, expand **Serviceability > Hardware > MES Tasks > Open MES**.
 - d. Click **Add MES Order Number**.
 - e. Enter the number, and click **OK**.
 - f. Click the newly created order number, and click **Next**. The details of the order number are displayed.
 - g. Click **Cancel** to close the window.
 - h. In the Tasks area, expand **Serviceability > Hardware > MES Tasks**.
- If you are using an HMC Enhanced + Tech Preview (Pre-GA) or HMC Enhanced+ interface, complete the following steps:



- a. In the navigation area, click the **Resources** icon , and then click **All Systems**.
 - b. Click the system name for which you want to install the part.
 - c. In the navigation area, click **Serviceability**.
2. In the Serviceability window, click **Add FRU** (field replaceable unit).
 3. In the Add/Install/Remove Hardware-Add FRU, Select FRU Type window, select the system or enclosure into which you are installing the feature.
 4. Select the type of feature you are installing, and click **Next**.
 5. Select the location code where you will install the feature, and click **Add**.
 6. After the part is listed in the **Pending Actions** section, click **Launch Procedure** and follow the instructions to install the feature.

Note: The HMC might open external instructions for installing the feature. If so, follow those instructions to install the feature.

Removing a part by using the HMC

Learn how to remove a part by using the Hardware Management Console (HMC).

To remove a part in a system or an expansion unit by using the HMC, complete the following steps:

1. Choose one of the following navigation options depending on the interface type of the HMC:
 - If you are using an HMC Classic or HMC Enhanced interface, complete the following steps:
 - a. In the navigation area, expand **Systems Management > Servers**.
 - b. Select the managed system from which you are removing a part.
 - c. In the Tasks area, expand **Serviceability > Hardware > MES Tasks > Remove FRU**.
 - If you are using an HMC Enhanced + Tech Preview (Pre-GA) or HMC Enhanced+ interface, complete the following steps:



- a. In the navigation area, click the **Resources** icon  , and then click **All Systems**.
 - b. Click the system name for which you want to remove a part.
 - c. In the navigation area, click **Serviceability**.
 - d. In the Serviceability window, click **Remove FRU**.
2. In the Add/Install/Remove Hardware - Remove FRU, Select FRU Type window, select the system or enclosure from which you are removing the part.
 3. Select the type of part that you are removing, and click **Next**.
 4. Select the location of the part that you are removing, and click **Add**.
 5. After the part is listed in the **Pending Actions** section, click **Launch Procedure** and follow the instructions to remove the part.

Note: The HMC might display the IBM Knowledge Center instructions for removing the part. If so, follow those instructions to remove the part.

Repairing a part by using the HMC

You can use the Hardware Management Console (HMC) to complete many service actions, including repairing a field-replaceable unit (FRU) or part.

1. Choose one of the following navigation options depending on the interface type of the Hardware Management Console (HMC):
 - If you are using an HMC Classic or HMC Enhanced interface, complete the following steps:
 - a. In the navigation area, expand **Systems Management > Servers**.
 - b. Select the managed system for which you want to repair a part.
 - c. In the Tasks area, expand **Serviceability > Manage Serviceable Events**.
 - If you are using an HMC Enhanced + Tech Preview (Pre-GA) or HMC Enhanced+ interface, complete the following step:



- a. In the navigation area, click the **Resources** icon  , and then click **All Systems**.
 - b. Click the system name for which you want to remove a part.
 - c. In the navigation area, click **Serviceability**.
 - d. In the Serviceability window, click **Serviceable Events Manager**.
- Note:** You can also access **Serviceable Events Manager** option from the **Actions** list after selecting the system.
2. In the Manage Serviceable Events window, specify the event criteria, error criteria, and FRU criteria. If you do not want the results to be filtered, select **ALL**.
 3. Click **OK**. The Manage Serviceable Events - Serviceable Event Overview window displays all of the events that match your criteria. The information that is displayed in the compact table view includes the following details:

- Problem number
- PMH number
- Reference code - click the Reference code to display a description of the problem reported and actions that can be taken to fix the problem.
- Status of the problem
- Last reported time of the problem
- Failing MTMS of the problem

Note: The full table view includes more detailed information, including reporting MTMS, first reported time, and serviceable event text.

4. Select a serviceable event and use the **Selected** drop-down menu to select **Repair**.
5. Follow the instructions to repair the part.

Note: The HMC might open IBM Knowledge Center instructions for repairing the part. If so, follow those instructions to repair the part.

Power cords

Use these procedures to disconnect and connect the power cords on IBM Power Systems servers that contain the POWER8 processor.

Disconnecting the power cords from the system

Use this procedure to disconnect the power cords from the system.

To disconnect the power cords from the system, complete the following steps:

1. Open the rear rack door on the system unit that you are servicing.
2. Identify the system unit that you are servicing in the rack.
3. Disconnect the power cords (**B**) from the system unit. See Figure 56 on page 94, Figure 57 on page 94, or Figure 58 on page 95 or depending on the type of your system.

Notes:

- This system might be equipped with two or more power supplies. If the removing and replacing procedures require the power to be off, then ensure that all the power sources to the system have been completely disconnected.
- The power cord is fastened to the system using the hook-and-loop fastener (**A**). If you are placing the system in a service position after disconnecting the power cords, then ensure that you unstrap the fastener.

Figure 53 on page 93 shows the supported alternate current (AC) and high voltage direct current (HVDC) connectors. Figure 54 on page 93 and Figure 55 on page 93 show the supported connectors and power distribution unit (PDU) for 8408-44E.

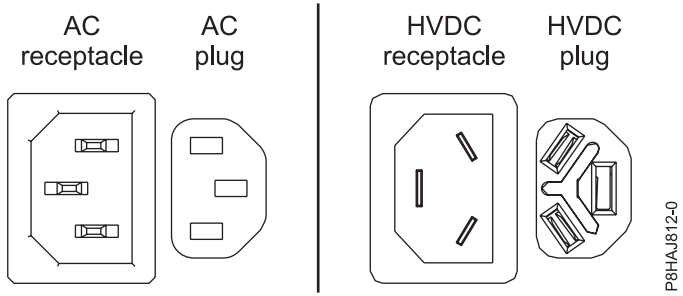

Figure 53. AC and HVDC connectors

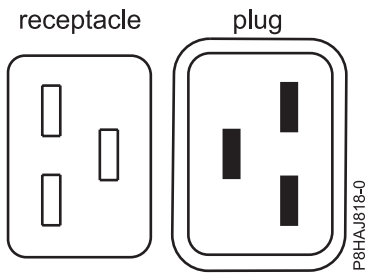

Figure 54. Connectors for the 8408-44E system

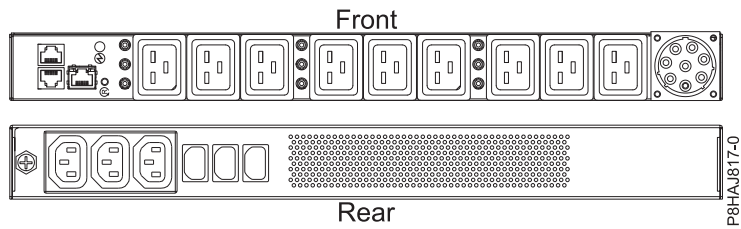

Figure 55. PDU for the 8408-44E system

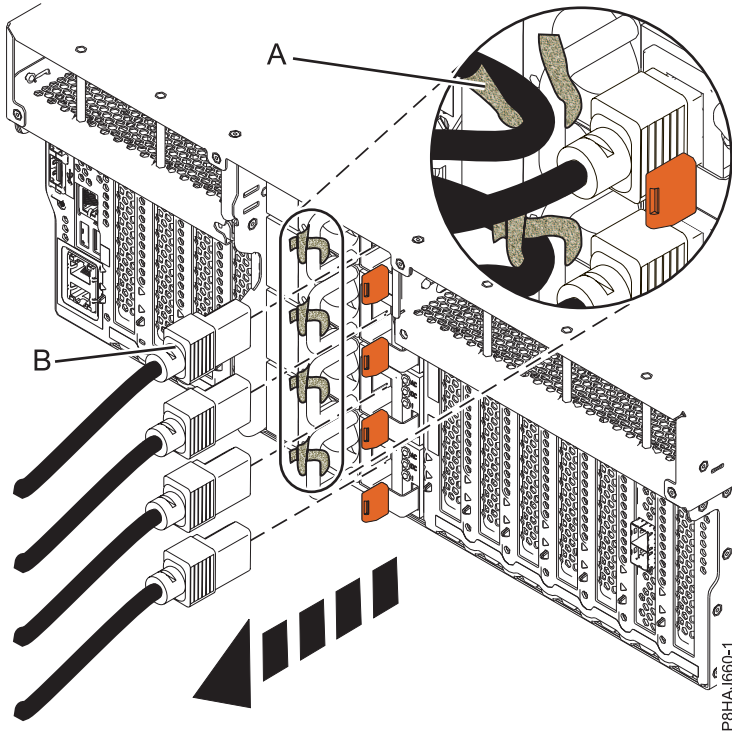

Figure 56. Removing the power cords from an 8247-42L, 8286-41A, or 8286-42A system

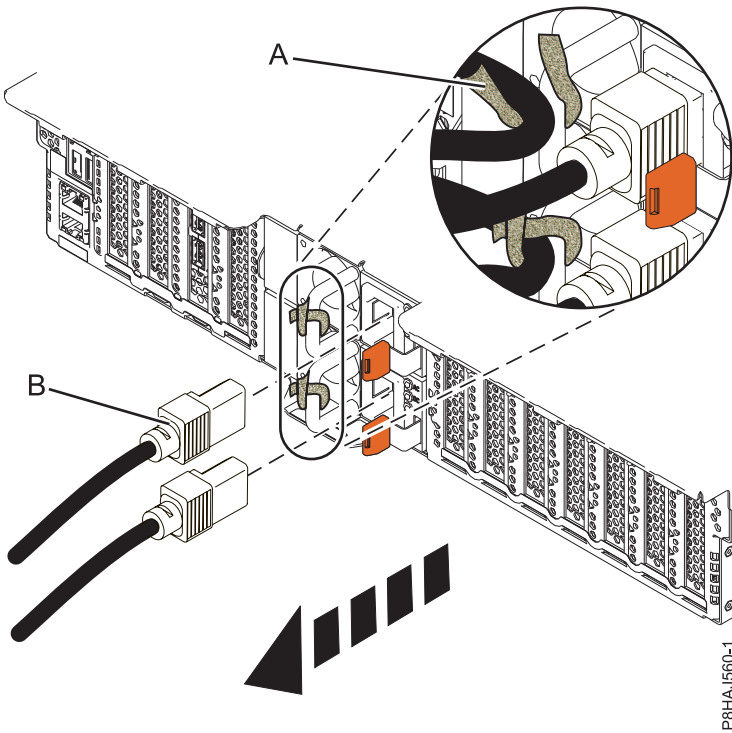

Figure 57. Removing the power cords from an 5148-21L, 5148-22L, 8247-21L, 8247-22L, 8284-21A, or 8284-22A system

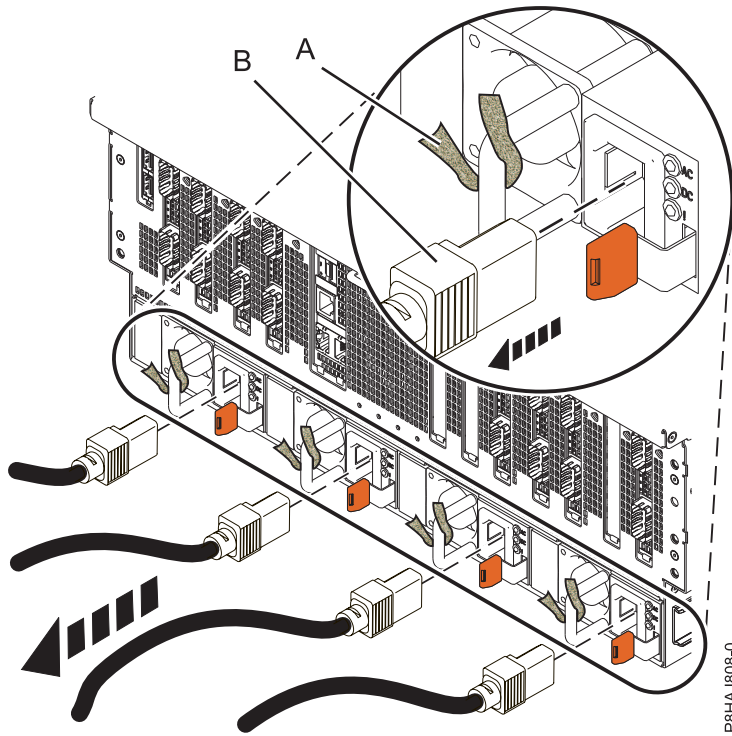

Figure 58. Removing the power cords from an 8408-44E or 8408-E8E system

Connecting the power cords to the system

Use this procedure to connect the power cords to the system.

To connect the power cords to the system, complete the following steps:

1. Open the rear rack door on the system unit that you are servicing.
2. Reconnect the power cords (A) to the system unit. See Figure 62 on page 96, Figure 63 on page 97, or Figure 64 on page 97 depending on the type of your system. Figure 59 shows the supported alternate current (AC) and high voltage direct current (HVDC) connectors. Figure 60 on page 96 and Figure 61 on page 96 show the supported connectors and power distribution unit (PDU) for 8408-44E.

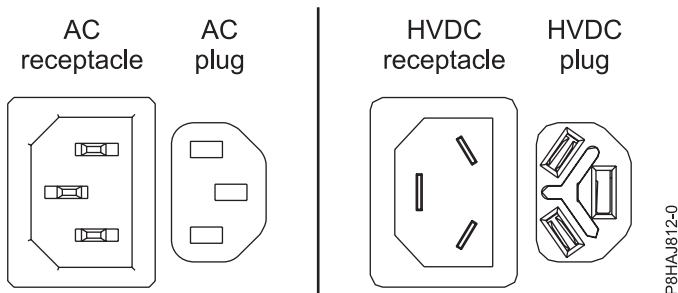

Figure 59. AC and HVDC connectors

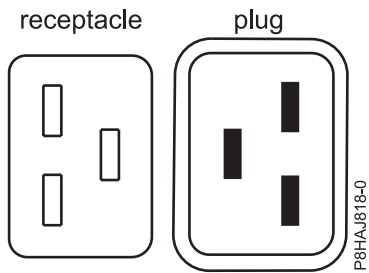

Figure 60. Connectors for the 8408-44E system

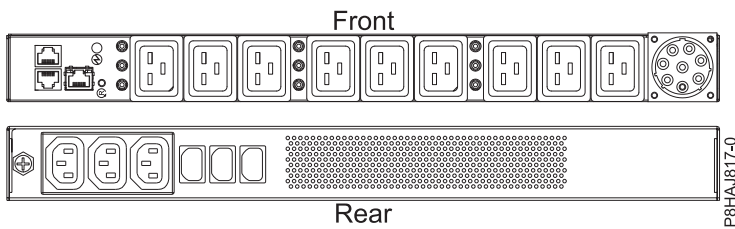

Figure 61. PDU for the 8408-44E system

3. Fasten the power cords to the system using the hook-and-loop fasteners **(B)**.

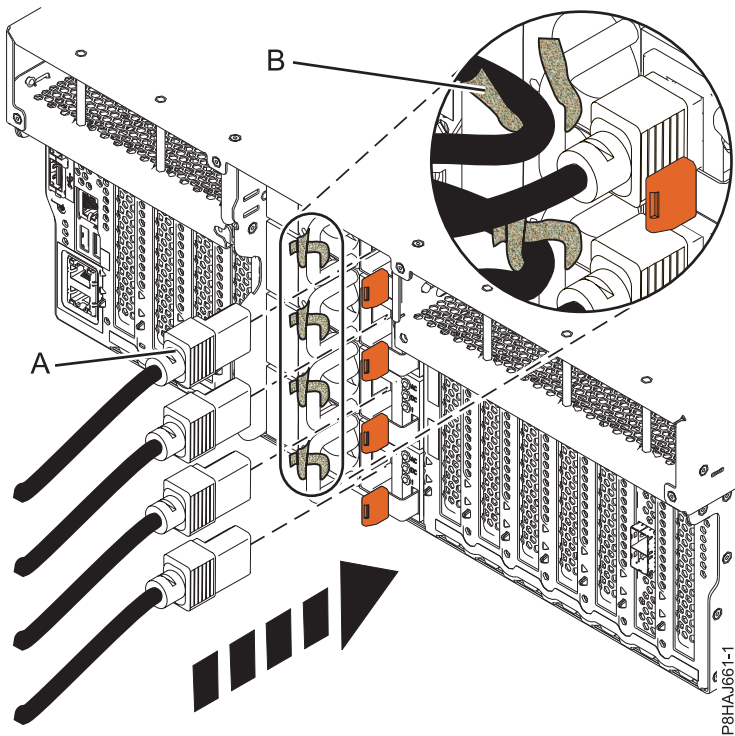

Figure 62. Connecting the power cords to an 8247-42L, 8286-41A, or 8286-42A system

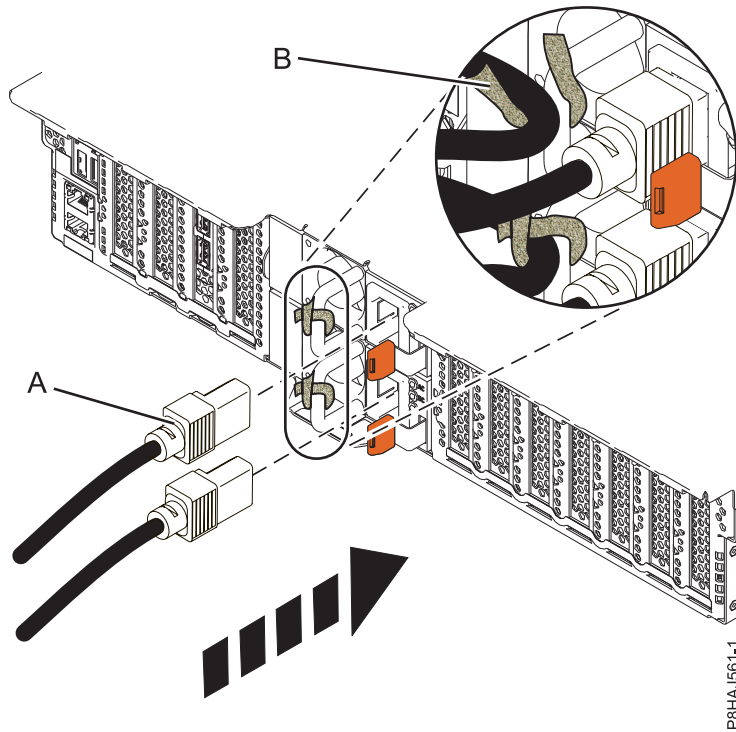

Figure 63. Connecting the power cords to a 5148-21L, 5148-22L, 8247-21L, 8247-22L, 8284-21A, or 8284-22A system

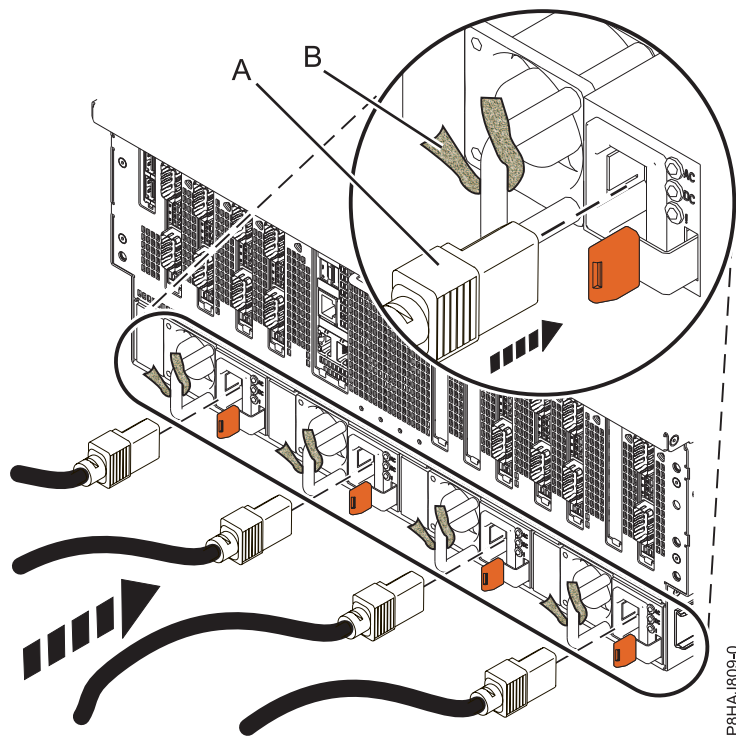

Figure 64. Connecting the power cords to an 8408-44E or 8408-E8E system

4. Close the rack door at the rear of the system.

Removing and replacing covers on an 8408-44E or 8408-E8E system

Use these instructions to remove and replace the covers in an 8408-44E or 8408-E8E system so that you can access the hardware parts or perform service.

Removing the front cover from an 8408-44E or 8408-E8E system

Use this procedure to remove the cover so that you can access the components or perform service.

To remove the front cover, complete the following steps:

1. If necessary, open the front rack door.
2. Ensure that you have the electrostatic discharge (ESD) wrist strap attached. If not, attach it now.
3. Place your fingers on the indentations and pull the latches **(B)** located on both sides of the cover.

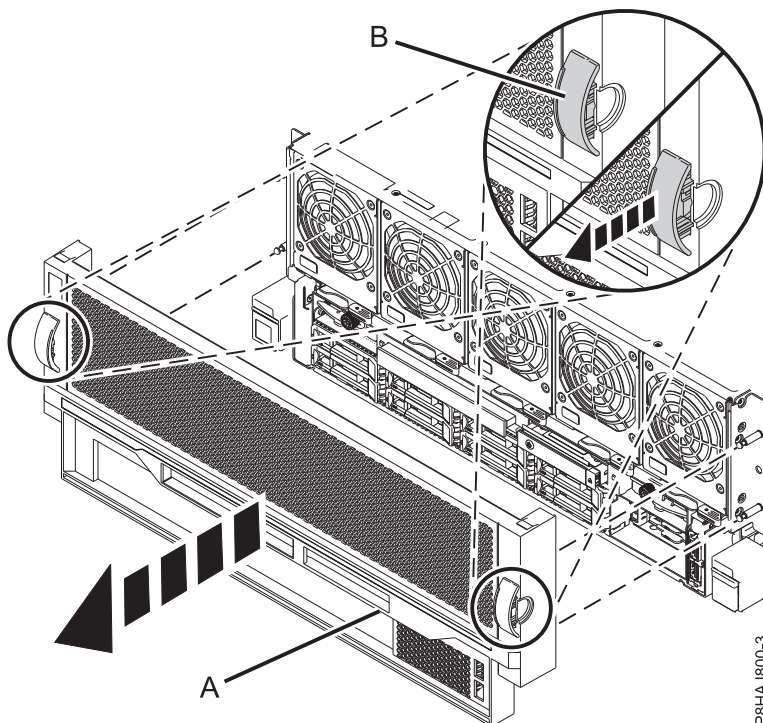

Figure 65. Removing the front cover

4. Pull the cover **(A)** away from the system.

Installing the front cover on an 8408-44E or 8408-E8E system

Use this procedure to install the cover after accessing the components or performing service.

To install the front cover, complete the following steps:

1. Ensure that you have the electrostatic discharge (ESD) wrist strap attached. If not, attach it now.
2. Position the cover **(A)** on the front of the system unit so that the four pins **(B)** on the system match the four holes at the rear of the cover.

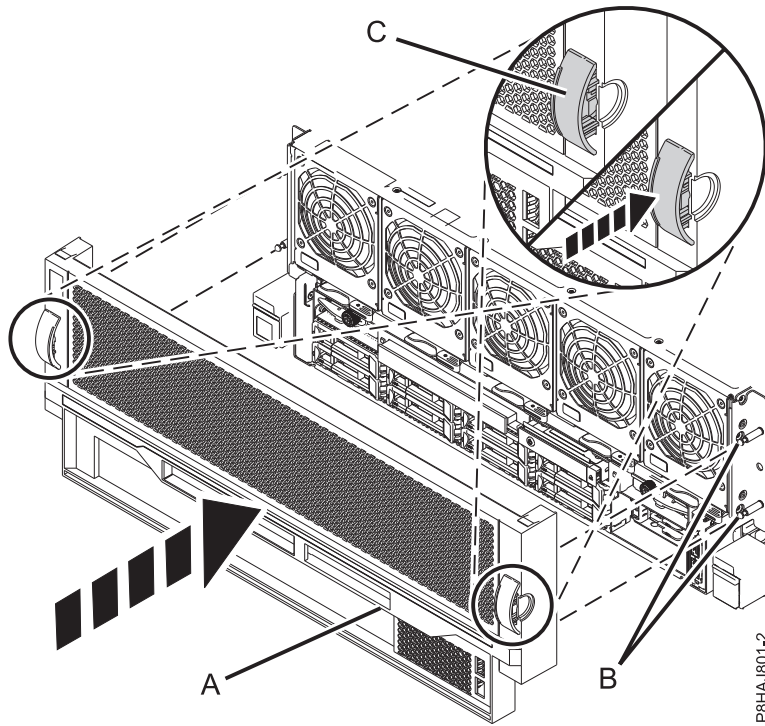

Figure 66. Installing the front cover

3. Press the tabs (C) to snap the cover into position.
4. Close the front door of the rack.

Removing the service access cover from an 8408-44E or 8408-E8E system

Use this procedure to remove the service access cover from an 8408-44E or 8408-E8E system.

To remove the service access cover, complete the following steps:

1. Ensure that you have the electrostatic discharge (ESD) wrist strap attached. If not, attach it now.
2. Push the release latches (A) in the direction shown.
3. Slide the cover (B) off the system unit. When the front of the service access cover has cleared the upper frame ledge, lift the cover up and off the system unit.

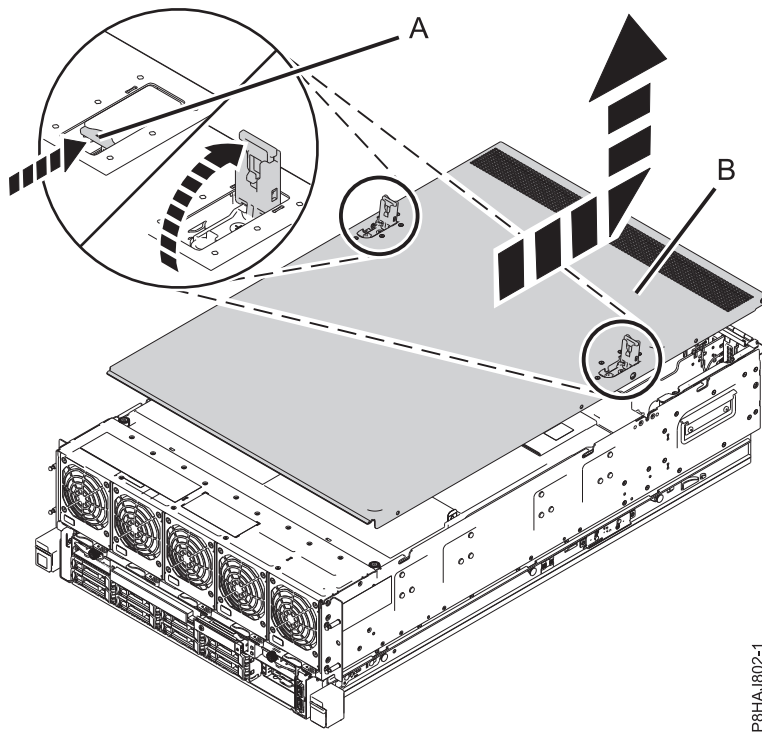

P8HAJ802-1

Figure 67. Removing the service access cover

Installing the service access cover on an 8408-44E or 8408-E8E system

Use this procedure to install the service access cover.

To install the service access cover, complete the following steps:

1. Ensure that you have the electrostatic discharge (ESD) wrist strap attached. If not, attach it now.
2. Slide the cover (A) onto the system unit.
3. Close the release latches (B) by pushing it in the direction shown.

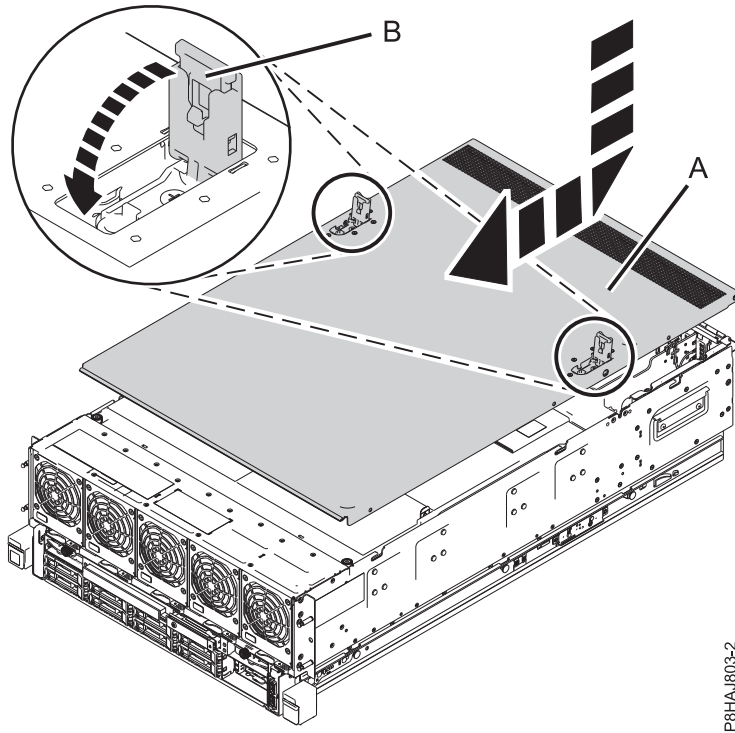

P8HAJ803-2

Figure 68. Installing the service access cover

Removing and replacing the safety cover in an 8408-44E or 8408-E8E system

Use these procedures to remove and replace the safety cover in an 8408-44E or 8408-E8E system.

Removing the safety cover from an 8408-44E or 8408-E8E system

Use this procedure to remove the safety cover from an 8408-44E or 8408-E8E system.

To remove the safety cover, complete the following steps:

1. Ensure that you have the electrostatic discharge (ESD) wrist strap attached. If not, attach it now.
2. Loosen the thumbscrew (A) located at the rear of the cover, by turning it in the direction shown in Figure 69 on page 102.
3. Slide the safety cover (B) toward the rear of the system. When the front of the cover has cleared the upper frame ledge, lift the cover up and off the system.

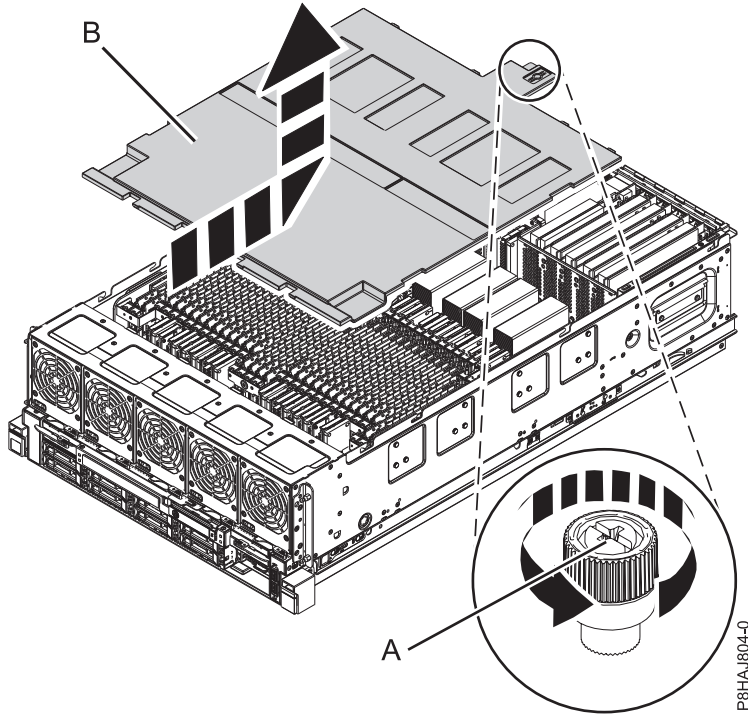

Figure 69. Removing the safety cover

Replacing the safety cover in an 8408-44E or 8408-E8E system

Use this procedure to replace the safety cover in an 8408-44E or 8408-E8E system.

To replace the safety cover, complete the following steps:

1. Ensure that you have the electrostatic discharge (ESD) wrist strap attached. If not, attach it now.
2. Push the safety cover (A) toward the chassis.
3. Tighten the thumbscrew (B) by turning it in the direction shown in Figure 70 on page 103 to fix the safety cover to the chassis.

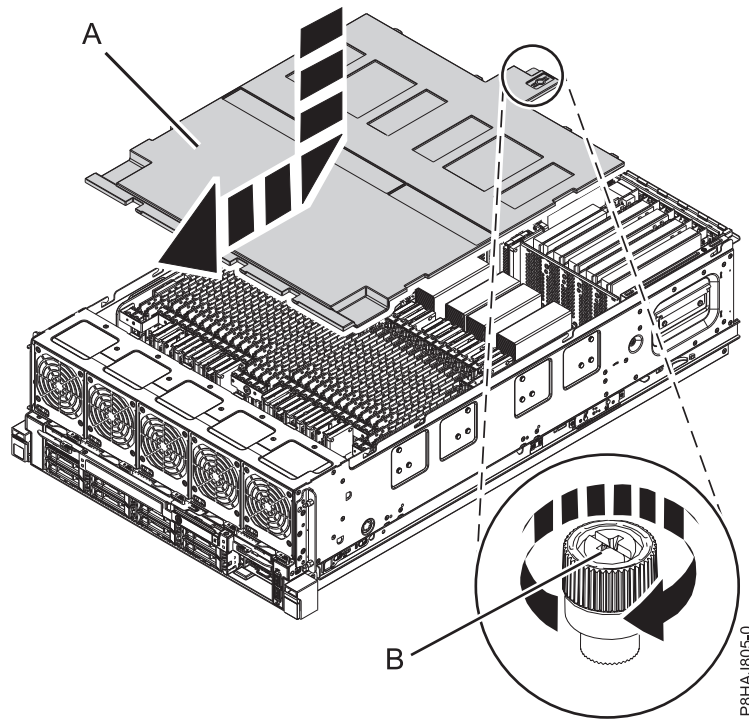

Figure 70. Replacing the safety cover

Opening and closing the I/O latch in an 8408-44E or 8408-E8E system

Use this procedure to open and close the I/O latch in an 8408-44E or 8408-E8E system.

The 8408-44E or 8408-E8E system is equipped with two I/O latches on either side of the system.

Opening the I/O latch in an 8408-44E or 8408-E8E system

Use this procedure to open the I/O latch in an 8408-44E or 8408-E8E system.

To open the I/O latch, complete the following steps:

1. Ensure that you have the electrostatic discharge (ESD) wrist strap attached. If not, attach it now.
2. Loosen the thumbscrew (A), by turning it in the direction shown in Figure 71 on page 104.
3. Move service access latch (B) to the open position, by pushing it in the direction shown in Figure 71 on page 104.

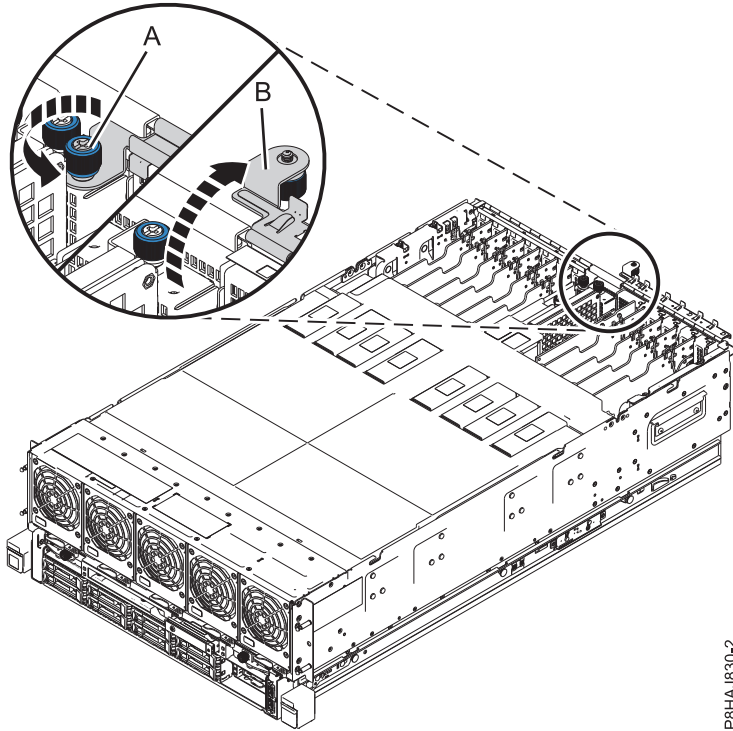

P8HAJ830-2

Figure 71. Opening the I/O latch

Closing the I/O latch in an 8408-44E or 8408-E8E system

Use this procedure to close the I/O latch in an 8408-44E or 8408-E8E system.

To close the I/O latch, complete the following steps:

1. Ensure that you have the electrostatic discharge (ESD) wrist strap attached. If not, attach it now.
2. Close the service access latch (**B**) by pushing it toward the chassis as shown in Figure 72 on page 105.
3. Tighten the thumbscrew (**A**) by turning it in the direction shown, to fix the latch to the chassis.

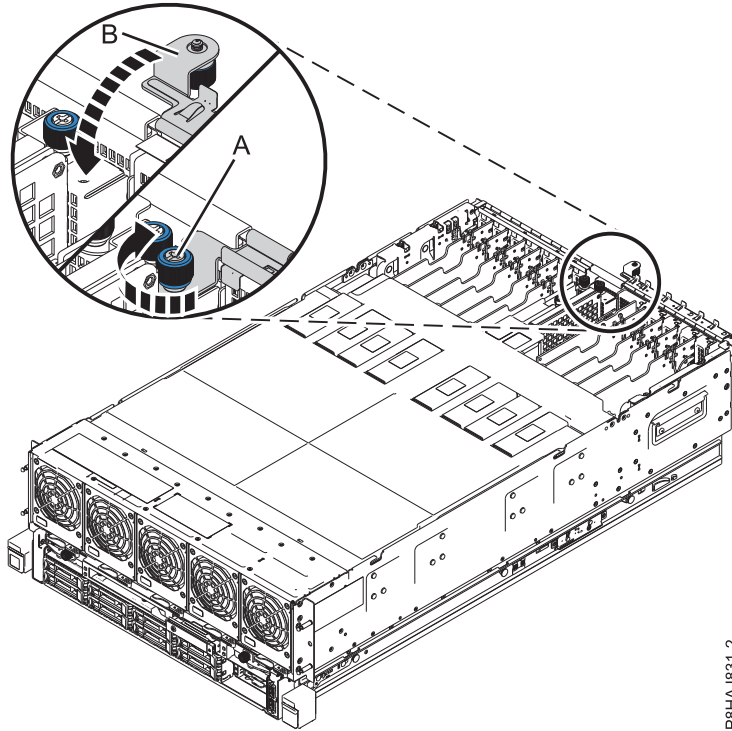

P8HAJ831-2

Figure 72. Closing the I/O latch

Deactivating an identify LED

Learn how to deactivate an identifying LED for a part or enclosure.

Deactivating a system attention LED by using the operating system or VIOS tools

You can use the AIX, IBM i, or Linux operating system, or the Virtual I/O Server (VIOS) tools to deactivate a system attention LED.

Deactivating the indicator light for a part by using AIX diagnostics

Use this procedure to turn off any indicator light that you turned on as a part of a service action.

To deactivate the indicator light, complete the following steps:

1. Log in as root user.
2. At the command line, type `diag` and press Enter.
3. From the **Function Selection** menu, select **Task Selection** and press Enter.
4. From the **Task Selection** menu, select **Identify and Attention Indicators** and press Enter.
5. From the list of lights, select the location code for the part and press Enter. When a light is activated for a part, an I character precedes the location code.
6. Select **Commit**.
7. Exit to the command line.

Deactivating the indicator light by using the IBM i operating system

Use this procedure to turn off any indicator light that you turned on as a part of a service action.

To deactivate the indicator light, follow these steps:

1. Sign on to an IBM i session, **with at least service level authority**.
2. On the command line of the session, type `strsst` and press Enter.

Note: If you cannot get to the System Service Tools display, use function 21 from the control panel. Alternatively, if the system is managed by a Hardware Management Console (HMC), use the Service Focal Point utilities to get to the Dedicated Service Tools (DST) display.

3. Type your service tools user ID and service tools password on the System Service Tools (SST) Sign On display and press Enter.

Remember: The service tools password is case-sensitive.

4. Select **Start a service tool** from the System Service Tools (SST) display and press Enter.
5. Select **Hardware service manager** from the Start a Service Tool display and press Enter.
6. Select **Work with service action log** from the Hardware Service Manager display and press Enter.
7. On the Select Timeframe display, change the **From: Date and Time** field to a date and time prior to when the problem occurred.
8. Search for an entry that matches one or more conditions of the problem:
 - System reference code
 - Resource
 - Date and time
 - Failing item list
9. Select option 2 (Display failing item information) to display the service action log entry.
10. Select option 2 (Display details) to display location information for the failing part to be replaced. The information displayed in the date and time fields is the date and time for the first occurrence of the specific system reference code for the resource displayed during the time range selected.
11. Select option 7 (Indicator off) to turn off the indicator light.
12. Select the **Acknowledge all errors** function at the bottom of the Service Action Log display, if all problems have been resolved.
13. Close the log entry by selecting option 8 (Close new entry) on the Service Action Log Report display.

Deactivating the indicator light by using the Linux operating system

After you complete a removal and replacement procedure, you can deactivate the indicator light.

To deactivate the indicator light, complete the following steps:

1. Log in as root user.
2. At the command line, type `/usr/sbin/usysident -s normal -l location_code` and press Enter.

Related information:

 [Service and productivity tools for Linux on Power servers](#)

IBM provides hardware diagnostic aids and productivity tools, and installation aids for Linux operating systems on IBM Power Systems servers.

Deactivating the indicator light for a part by using the VIOS tools

Use this procedure to turn off any indicator light that you turned on as a part of a service action.

To deactivate the indicator light, complete the following steps:

1. Log in as root user.
2. At the command line, type `diagmenu` and press Enter.

3. From the **Function Selection** menu, select **Task Selection** and press Enter.
4. From the **Task Selection** menu, select **Identify and Attention Indicators** and press Enter.
5. From the list of lights, select the location code for the part and press Enter. When a light is activated for a part, an I character precedes the location code.
6. Select **Commit**.
7. Exit to the command line.

Deactivating a system attention LED by using the ASMI

You can use the Advanced System Management Interface (ASMI) to deactivate a system attention LED.

Deactivating the identify LED by using the ASMI when you know the location code

Learn how to deactivate the identify LED by using the Advanced System Management Interface (ASMI) when you know the location code.

You can specify the location code of any indicator to view or modify its current state. If you provide the wrong location code, the ASMI attempts to go to the next higher level of the location code.

The next level is the base-level location code for that field replaceable unit (FRU). For example, a user types the location code for the FRU located on the second memory module slot of the third enclosure in the system. If the location code for the second memory module slot is incorrect (the FRU does not exist at this location), an attempt to set the indicator for the third enclosure is initiated. This process continues until a FRU is located or no other level is available.

To complete this operation, your authority level must be one of the following levels:

- Administrator
- Authorized service provider

To change the current state of an indicator, complete the following steps:

1. On the ASMI Welcome pane, specify your user ID and password, and click **Log In**.
2. In the navigation area, expand **System Configuration > Service Indicators > Indicators by Location code**.
3. In the **Location code** field, type the location code of the FRU and click **Continue**.
4. From the **Identify indicator status** list, select **Off**.
5. Click **Save settings**.

Deactivating the identify LED by using the ASMI when you do not know the location code

Learn how to deactivate the identify LED by using the Advanced System Management Interface (ASMI) when you do not know the location code.

You can turn off the identify indicators in each enclosure.

To complete this operation, your authority level must be one of the following levels:

- Administrator
- Authorized service provider

To disable the enclosure indicator states, complete the following steps:

1. On the ASMI Welcome pane, specify your user ID and password, and click **Log In**.
2. In the navigation area, expand **System Configuration > Service Indicators > Enclosure Indicators**. All servers and enclosures managed by the ASMI will display.
3. Select the server or enclosure with the part that needs to be replaced and click **Continue**. The location code identifiers are listed.

4. Select the location code identifier and select **Off**.
5. To save the changes made to the state of one or more FRU indicators, click **Save settings**.

Deactivating a check log indicator (system information indicator) by using the ASMI

You can deactivate a check log indicator (system information indicator) or logical partition check log indicator by using the ASMI.

The check log indicator provides a visual signal that the system as a whole requires attention or service. Each system has a single check log indicator. When an event occurs that either needs your intervention or that of service and support, the check log indicator lights continuously. The check log indicator is turned on when an entry is made in the service processor error log. The error entry is transmitted to the system error log and to the operating system error log.

To complete this operation, your authority level must be one of the following levels:

- Administrator
- Authorized service provider

To turn off the check log indicator, do the following steps:

1. In the ASMI Welcome pane, specify your user ID and password, and click **Log In**.
2. In the navigation area, expand **System Configuration > Service Indicators > System Information Indicator**.
3. In the right pane, click **Turn off system information indicator**. If the attempt is unsuccessful, an error message is displayed.

Deactivating LEDs by using the HMC

Use this procedure to deactivate LEDs by using the Hardware Management Console (HMC).

Deactivating a system attention LED or partition LED by using the HMC

Use this procedure to deactivate a system attention LED or partition LED by using the Hardware Management Console (HMC).

To deactivate an LED by using the HMC, complete the following steps:

Choose one of the following navigation options depending on the interface type of the HMC:

- If you are using an HMC Classic or HMC Enhanced interface, complete the following steps:
 1. In the navigation area, click **Systems Management > Servers**.
 2. In the content pane, select the system.
 3. From the **Tasks** menu, click **Operations > LED Status**.
 4. Click **Identify LED**. The Identify LED window opens. The selected system and its LED state are displayed in the upper part of the window. The logical partition and its LED state are displayed in the lower part of the window. From the Identify LED window, you can deactivate both the system attention LED and the logical partition LED.
 5. Click **Deactivate Attention LED**. A confirmation window is displayed that provides the following information:
 - A verification that the system attention LED was deactivated.
 - An indication that there still might be open problems within the system.
 - An indication that you cannot deactivate the system attention LED.
 6. Select one of the logical partitions in the lower table, and click **Deactivate partition LED**. A confirmation window is displayed that provides the following information:
 - A verification that the logical partition attention LED was deactivated.

- An indication that there still might be open problems within the logical partition.
- An indication that you cannot deactivate the logical partition attention LED.
- If you are using an HMC Enhanced + Tech Preview (Pre-GA) or HMC Enhanced+ interface, complete the following steps:



1. In the navigation area, click the **Resources** icon , and then click **All Systems**.
2. Click the server name for which you want to deactivate the attention LED.
3. In the navigation area, click **System Actions** > **Attention LED**.
4. Click **Turn Attention LED Off**. A confirmation window that provides the following information is displayed.
 - A verification that the system attention LED was deactivated.
 - An indication that there still might be open problems within the system.
5. Click **OK**.

Deactivating an identify LED for a FRU by using the HMC

Learn how to deactivate an identify LED by using the Hardware Management Console (HMC).

To deactivate an identify LED for a FRU by using the HMC, complete the following steps:

1. Choose one of the following navigation options depending on the interface type of the HMC:
 - If you are using an HMC Classic or HMC Enhanced interface, complete the following steps:
 - a. In the navigation area, click **Systems Management** > **Servers**.
 - b. In the content pane, select the system.
 - c. Click **Tasks** > **Operations** > **LED Status** > **Identify LED**. The Identify LED, Select Enclosure window is displayed.
 - If you are using an HMC Enhanced + Tech Preview (Pre-GA) or HMC Enhanced+ interface, complete the following steps.



- a. In the navigation area, click the **Resources** icon , and then click **All Systems**.
- b. To view the actions for that server, click the name of the required server.
- c. In the navigation area, click **System Actions** > **Attention LED** > **Identify Attention LED**. The Identify LED, Select Enclosure window is displayed.
2. To deactivate an identify LED for a FRU, select an enclosure from the table, and then click **Selected** > **List FRUs**.
3. Select one or more FRUs from the table, and click **Deactivate LED**. The associated LED is turned off.

Deactivating an identify LED for an enclosure by using the HMC

Learn how to deactivate an identify LED by using the Hardware Management Console (HMC).

To deactivate an identify LED for an enclosure by using the HMC, complete the following steps:

1. Choose one of the following navigation options depending on the interface type of the HMC:
 - If you are using an HMC Classic or HMC Enhanced interface, complete the following steps:
 - a. In the navigation area, click **Systems Management** > **Servers**.
 - b. In the content pane, select the system.
 - c. Click **Tasks** > **Operations** > **LED Status** > **Identify LED**.
 - If you are using an HMC Enhanced + Tech Preview (Pre-GA) or HMC Enhanced+ interface, complete the following steps.



- a. In the navigation area, click the **Resources** icon  , and then click **All Systems**.
 - b. To view the actions for that server, click the name of the required server.
 - c. In the navigation area, click **System Actions > Attention LED > Identify Attention LED**.
2. To deactivate an identify LED for an enclosure, select an enclosure from the table, and click **Deactivate LED**. The associated LED is turned off.

Notices

This information was developed for products and services offered in the US.

IBM may not offer the products, services, or features discussed in this document in other countries. Consult your local IBM representative for information on the products and services currently available in your area. Any reference to an IBM product, program, or service is not intended to state or imply that only that IBM product, program, or service may be used. Any functionally equivalent product, program, or service that does not infringe any IBM intellectual property right may be used instead. However, it is the user's responsibility to evaluate and verify the operation of any non-IBM product, program, or service.

IBM may have patents or pending patent applications covering subject matter described in this document. The furnishing of this document does not grant you any license to these patents. You can send license inquiries, in writing, to:

*IBM Director of Licensing
IBM Corporation
North Castle Drive, MD-NC119
Armonk, NY 10504-1785
US*

INTERNATIONAL BUSINESS MACHINES CORPORATION PROVIDES THIS PUBLICATION "AS IS" WITHOUT WARRANTY OF ANY KIND, EITHER EXPRESS OR IMPLIED, INCLUDING, BUT NOT LIMITED TO, THE IMPLIED WARRANTIES OF NON-INFRINGEMENT, MERCHANTABILITY OR FITNESS FOR A PARTICULAR PURPOSE. Some jurisdictions do not allow disclaimer of express or implied warranties in certain transactions, therefore, this statement may not apply to you.

This information could include technical inaccuracies or typographical errors. Changes are periodically made to the information herein; these changes will be incorporated in new editions of the publication. IBM may make improvements and/or changes in the product(s) and/or the program(s) described in this publication at any time without notice.

Any references in this information to non-IBM websites are provided for convenience only and do not in any manner serve as an endorsement of those websites. The materials at those websites are not part of the materials for this IBM product and use of those websites is at your own risk.

IBM may use or distribute any of the information you provide in any way it believes appropriate without incurring any obligation to you.

The performance data and client examples cited are presented for illustrative purposes only. Actual performance results may vary depending on specific configurations and operating conditions.

Information concerning non-IBM products was obtained from the suppliers of those products, their published announcements or other publicly available sources. IBM has not tested those products and cannot confirm the accuracy of performance, compatibility or any other claims related to non-IBM products. Questions on the capabilities of non-IBM products should be addressed to the suppliers of those products.

Statements regarding IBM's future direction or intent are subject to change or withdrawal without notice, and represent goals and objectives only.

All IBM prices shown are IBM's suggested retail prices, are current and are subject to change without notice. Dealer prices may vary.

This information is for planning purposes only. The information herein is subject to change before the products described become available.

This information contains examples of data and reports used in daily business operations. To illustrate them as completely as possible, the examples include the names of individuals, companies, brands, and products. All of these names are fictitious and any similarity to actual people or business enterprises is entirely coincidental.

If you are viewing this information in softcopy, the photographs and color illustrations may not appear.

The drawings and specifications contained herein shall not be reproduced in whole or in part without the written permission of IBM.

IBM has prepared this information for use with the specific machines indicated. IBM makes no representations that it is suitable for any other purpose.

IBM's computer systems contain mechanisms designed to reduce the possibility of undetected data corruption or loss. This risk, however, cannot be eliminated. Users who experience unplanned outages, system failures, power fluctuations or outages, or component failures must verify the accuracy of operations performed and data saved or transmitted by the system at or near the time of the outage or failure. In addition, users must establish procedures to ensure that there is independent data verification before relying on such data in sensitive or critical operations. Users should periodically check IBM's support websites for updated information and fixes applicable to the system and related software.

Homologation statement

This product may not be certified in your country for connection by any means whatsoever to interfaces of public telecommunications networks. Further certification may be required by law prior to making any such connection. Contact an IBM representative or reseller for any questions.

Accessibility features for IBM Power Systems servers

Accessibility features assist users who have a disability, such as restricted mobility or limited vision, to use information technology content successfully.

Overview

The IBM Power Systems servers include the following major accessibility features:

- Keyboard-only operation
- Operations that use a screen reader

The IBM Power Systems servers use the latest W3C Standard, WAI-ARIA 1.0 (www.w3.org/TR/wai-aria/), to ensure compliance with US Section 508 (www.access-board.gov/guidelines-and-standards/communications-and-it/about-the-section-508-standards/section-508-standards) and Web Content Accessibility Guidelines (WCAG) 2.0 (www.w3.org/TR/WCAG20/). To take advantage of accessibility features, use the latest release of your screen reader and the latest web browser that is supported by the IBM Power Systems servers.

The IBM Power Systems servers online product documentation in IBM Knowledge Center is enabled for accessibility. The accessibility features of IBM Knowledge Center are described in the Accessibility section of the IBM Knowledge Center help (www.ibm.com/support/knowledgcenter/doc/kc_help.html#accessibility).

Keyboard navigation

This product uses standard navigation keys.

Interface information

The IBM Power Systems servers user interfaces do not have content that flashes 2 - 55 times per second.

The IBM Power Systems servers web user interface relies on cascading style sheets to render content properly and to provide a usable experience. The application provides an equivalent way for low-vision users to use system display settings, including high-contrast mode. You can control font size by using the device or web browser settings.

The IBM Power Systems servers web user interface includes WAI-ARIA navigational landmarks that you can use to quickly navigate to functional areas in the application.

Vendor software

The IBM Power Systems servers include certain vendor software that is not covered under the IBM license agreement. IBM makes no representation about the accessibility features of these products. Contact the vendor for accessibility information about its products.

Related accessibility information

In addition to standard IBM help desk and support websites, IBM has a TTY telephone service for use by deaf or hard of hearing customers to access sales and support services:

TTY service
800-IBM-3383 (800-426-3383)
(within North America)

For more information about the commitment that IBM has to accessibility, see IBM Accessibility (www.ibm.com/able).

Privacy policy considerations

IBM Software products, including software as a service solutions, (“Software Offerings”) may use cookies or other technologies to collect product usage information, to help improve the end user experience, to tailor interactions with the end user, or for other purposes. In many cases no personally identifiable information is collected by the Software Offerings. Some of our Software Offerings can help enable you to collect personally identifiable information. If this Software Offering uses cookies to collect personally identifiable information, specific information about this offering’s use of cookies is set forth below.

This Software Offering does not use cookies or other technologies to collect personally identifiable information.

If the configurations deployed for this Software Offering provide you as the customer the ability to collect personally identifiable information from end users via cookies and other technologies, you should seek your own legal advice about any laws applicable to such data collection, including any requirements for notice and consent.

For more information about the use of various technologies, including cookies, for these purposes, see IBM’s Privacy Policy at <http://www.ibm.com/privacy> and IBM’s Online Privacy Statement at <http://www.ibm.com/privacy/details> the section entitled “Cookies, Web Beacons and Other Technologies” and the “IBM Software Products and Software-as-a-Service Privacy Statement” at <http://www.ibm.com/software/info/product-privacy>.

Trademarks

IBM, the IBM logo, and ibm.com are trademarks or registered trademarks of International Business Machines Corp., registered in many jurisdictions worldwide. Other product and service names might be trademarks of IBM or other companies. A current list of IBM trademarks is available on the web at Copyright and trademark information at www.ibm.com/legal/copytrade.shtml.

Linux is a registered trademark of Linus Torvalds in the United States, other countries, or both.

Electronic emission notices

When attaching a monitor to the equipment, you must use the designated monitor cable and any interference suppression devices supplied with the monitor.

Class A Notices

The following Class A statements apply to the IBM servers that contain the POWER8 processor and its features unless designated as electromagnetic compatibility (EMC) Class B in the feature information.

Federal Communications Commission (FCC) Statement

Note: This equipment has been tested and found to comply with the limits for a Class A digital device, pursuant to Part 15 of the FCC Rules. These limits are designed to provide reasonable protection against harmful interference when the equipment is operated in a commercial environment. This equipment generates, uses, and can radiate radio frequency energy and, if not installed and used in accordance with the instruction manual, may cause harmful interference to radio communications. Operation of this equipment in a residential area is likely to cause harmful interference, in which case the user will be required to correct the interference at his own expense.

Properly shielded and grounded cables and connectors must be used in order to meet FCC emission limits. IBM is not responsible for any radio or television interference caused by using other than recommended cables and connectors or by unauthorized changes or modifications to this equipment. Unauthorized changes or modifications could void the user's authority to operate the equipment.

This device complies with Part 15 of the FCC rules. Operation is subject to the following two conditions: (1) this device may not cause harmful interference, and (2) this device must accept any interference received, including interference that may cause undesired operation.

Industry Canada Compliance Statement

CAN ICES-3 (A)/NMB-3(A)

European Community Compliance Statement

This product is in conformity with the protection requirements of EU Council Directive 2014/30/EU on the approximation of the laws of the Member States relating to electromagnetic compatibility. IBM cannot accept responsibility for any failure to satisfy the protection requirements resulting from a non-recommended modification of the product, including the fitting of non-IBM option cards.

European Community contact:
IBM Deutschland GmbH
Technical Regulations, Abteilung M456
IBM-Allee 1, 71139 Ehningen, Germany
Tel: +49 800 225 5426
email: halloibm@de.ibm.com

Warning: This is a Class A product. In a domestic environment, this product may cause radio interference, in which case the user may be required to take adequate measures.

VCCI Statement - Japan

この装置は、クラスA 情報技術装置です。この装置を家庭環境で使用すると電波妨害を引き起こすことがあります。この場合には使用者が適切な対策を講ずるよう要求されることがあります。 VCCI-A

The following is a summary of the VCCI Japanese statement in the box above:

This is a Class A product based on the standard of the VCCI Council. If this equipment is used in a domestic environment, radio interference may occur, in which case, the user may be required to take corrective actions.

Japan Electronics and Information Technology Industries Association Statement

This statement explains the Japan JIS C 61000-3-2 product wattage compliance.

(一社) 電子情報技術産業協会 高調波電流抑制対策実施
要領に基づく定格入力電力値 : Knowledge Centerの各製品の
仕様ページ参照

This statement explains the Japan Electronics and Information Technology Industries Association (JEITA) statement for products less than or equal to 20 A per phase.

高調波電流規格 JIS C 61000-3-2 適合品

This statement explains the JEITA statement for products greater than 20 A, single phase.

高調波電流規格 JIS C 61000-3-2 準用品

本装置は、「高圧又は特別高圧で受電する需要家の高調波抑制対策ガイドライン」対象機器（高調波発生機器）です。

- 回路分類 : 6 (単相、PFC回路付)
- 換算係数 : 0

This statement explains the JEITA statement for products greater than 20 A per phase, three-phase.

高調波電流規格 JIS C 61000-3-2 準用品

本装置は、「高圧又は特別高圧で受電する需要家の高調波抑制対策ガイドライン」対象機器（高調波発生機器）です。

- 回路分類 : 5 (3相、PFC回路付)
- 換算係数 : 0

Electromagnetic Interference (EMI) Statement - People's Republic of China

声 明

此为 A 级产品, 在生活环境中, 该产品可能会造成无线电干扰。在这种情况下, 可能需要用户对其干扰采取切实可行的措施。

Declaration: This is a Class A product. In a domestic environment this product may cause radio interference in which case the user may need to perform practical action.

Electromagnetic Interference (EMI) Statement - Taiwan

警告使用者：

這是甲類的資訊產品，在居住的環境中使用時，可能會造成射頻干擾，在這種情況下，使用者會被要求採取某些適當的對策。

The following is a summary of the EMI Taiwan statement above.

Warning: This is a Class A product. In a domestic environment this product may cause radio interference in which case the user will be required to take adequate measures.

IBM Taiwan Contact Information:

台灣IBM 產品服務聯絡方式：
台灣國際商業機器股份有限公司
台北市松仁路7號3樓
電話：0800-016-888

Electromagnetic Interference (EMI) Statement - Korea

이 기기는 업무용 환경에서 사용할 목적으로 적합성평가를 받은 기기로서 가정용 환경에서 사용하는 경우 전파간섭의 우려가 있습니다.

Germany Compliance Statement

Deutschsprachiger EU Hinweis: Hinweis für Geräte der Klasse A EU-Richtlinie zur Elektromagnetischen Verträglichkeit

Dieses Produkt entspricht den Schutzanforderungen der EU-Richtlinie 2014/30/EU zur Angleichung der Rechtsvorschriften über die elektromagnetische Verträglichkeit in den EU-Mitgliedsstaaten und hält die Grenzwerte der EN 55022 / EN 55032 Klasse A ein.

Um dieses sicherzustellen, sind die Geräte wie in den Handbüchern beschrieben zu installieren und zu betreiben. Des Weiteren dürfen auch nur von der IBM empfohlene Kabel angeschlossen werden. IBM übernimmt keine Verantwortung für die Einhaltung der Schutzanforderungen, wenn das Produkt ohne Zustimmung von IBM verändert bzw. wenn Erweiterungskomponenten von Fremdherstellern ohne Empfehlung von IBM gesteckt/eingebaut werden.

EN 55022 / EN 55032 Klasse A Geräte müssen mit folgendem Warnhinweis versehen werden:
"Warnung: Dieses ist eine Einrichtung der Klasse A. Diese Einrichtung kann im Wohnbereich Funk-Störungen verursachen; in diesem Fall kann vom Betreiber verlangt werden, angemessene Maßnahmen zu ergreifen und dafür aufzukommen."

Deutschland: Einhaltung des Gesetzes über die elektromagnetische Verträglichkeit von Geräten

Dieses Produkt entspricht dem "Gesetz über die elektromagnetische Verträglichkeit von Geräten (EMVG)". Dies ist die Umsetzung der EU-Richtlinie 2014/30/EU in der Bundesrepublik Deutschland.

Zulassungsbescheinigung laut dem Deutschen Gesetz über die elektromagnetische Verträglichkeit von Geräten (EMVG) (bzw. der EMC Richtlinie 2014/30/EU) für Geräte der Klasse A

Dieses Gerät ist berechtigt, in Übereinstimmung mit dem Deutschen EMVG das EG-Konformitätszeichen - CE - zu führen.

Verantwortlich für die Einhaltung der EMV Vorschriften ist der Hersteller:
International Business Machines Corp.
New Orchard Road
Armonk, New York 10504
Tel: 914-499-1900

Der verantwortliche Ansprechpartner des Herstellers in der EU ist:
IBM Deutschland GmbH
Technical Relations Europe, Abteilung M456
IBM-Allee 1, 71139 Ehningen, Germany
Tel: +49 (0) 800 225 5426
email: HalloIBM@de.ibm.com

Generelle Informationen:

Das Gerät erfüllt die Schutzanforderungen nach EN 55024 und EN 55022 / EN 55032 Klasse A.

Electromagnetic Interference (EMI) Statement - Russia

ВНИМАНИЕ! Настоящее изделие относится к классу А.
В жилых помещениях оно может создавать
радиопомехи, для снижения которых необходимы
дополнительные меры

Class B Notices

The following Class B statements apply to features designated as electromagnetic compatibility (EMC) Class B in the feature installation information.

Federal Communications Commission (FCC) Statement

This equipment has been tested and found to comply with the limits for a Class B digital device, pursuant to Part 15 of the FCC Rules. These limits are designed to provide reasonable protection against harmful interference in a residential installation.

This equipment generates, uses, and can radiate radio frequency energy and, if not installed and used in accordance with the instructions, may cause harmful interference to radio communications. However, there is no guarantee that interference will not occur in a particular installation.

If this equipment does cause harmful interference to radio or television reception, which can be determined by turning the equipment off and on, the user is encouraged to try to correct the interference by one or more of the following measures:

- Reorient or relocate the receiving antenna.
- Increase the separation between the equipment and receiver.
- Connect the equipment into an outlet on a circuit different from that to which the receiver is connected.
- Consult an IBM-authorized dealer or service representative for help.

Properly shielded and grounded cables and connectors must be used in order to meet FCC emission limits. Proper cables and connectors are available from IBM-authorized dealers. IBM is not responsible for any radio or television interference caused by unauthorized changes or modifications to this equipment. Unauthorized changes or modifications could void the user's authority to operate this equipment.

This device complies with Part 15 of the FCC rules. Operation is subject to the following two conditions: (1) this device may not cause harmful interference, and (2) this device must accept any interference received, including interference that may cause undesired operation.

Industry Canada Compliance Statement

CAN ICES-3 (B)/NMB-3(B)

European Community Compliance Statement

This product is in conformity with the protection requirements of EU Council Directive 2014/30/EU on the approximation of the laws of the Member States relating to electromagnetic compatibility. IBM cannot accept responsibility for any failure to satisfy the protection requirements resulting from a non-recommended modification of the product, including the fitting of non-IBM option cards.

European Community contact:
IBM Deutschland GmbH
Technical Regulations, Abteilung M456
IBM-Allee 1, 71139 Ehningen, Germany
Tel: +49 800 225 5426
email: halloibm@de.ibm.com

VCCI Statement - Japan

この装置は、クラスB情報技術装置です。この装置は、家庭環境で使用することを目的としていますが、この装置がラジオやテレビジョン受信機に近接して使用されると、受信障害を引き起こすことがあります。

取扱説明書に従って正しい取り扱いをして下さい。 VCCI-B

Japan Electronics and Information Technology Industries Association Statement

This statement explains the Japan JIS C 61000-3-2 product wattage compliance.

(一社) 電子情報技術産業協会 高調波電流抑制対策実施
要領に基づく定格入力電力値 : Knowledge Centerの各製品の
仕様ページ参照

This statement explains the Japan Electronics and Information Technology Industries Association (JEITA) statement for products less than or equal to 20 A per phase.

高調波電流規格 JIS C 61000-3-2 適合品

This statement explains the JEITA statement for products greater than 20 A, single phase.

高調波電流規格 JIS C 61000-3-2 準用品

本装置は、「高圧又は特別高圧で受電する需要家の高調波抑制対策ガイドライン」対象機器（高調波発生機器）です。

- 回路分類 : 6 (単相、PFC回路付)
- 換算係数 : 0

This statement explains the JEITA statement for products greater than 20 A per phase, three-phase.

高調波電流規格 JIS C 61000-3-2 準用品

本装置は、「高圧又は特別高圧で受電する需要家の高調波抑制対策ガイドライン」対象機器（高調波発生機器）です。

- 回路分類 : 5 (3相、PFC回路付)
- 換算係数 : 0

IBM Taiwan Contact Information

台灣IBM 產品服務聯絡方式：
台灣國際商業機器股份有限公司
台北市松仁路7號3樓
電話：0800-016-888

Germany Compliance Statement

Deutschsprachiger EU Hinweis: Hinweis für Geräte der Klasse B EU-Richtlinie zur Elektromagnetischen Verträglichkeit

Dieses Produkt entspricht den Schutzanforderungen der EU-Richtlinie 2014/30/EU zur Angleichung der Rechtsvorschriften über die elektromagnetische Verträglichkeit in den EU-Mitgliedsstaaten und hält die Grenzwerte der EN 55022/ EN 55032 Klasse B ein.

Um dieses sicherzustellen, sind die Geräte wie in den Handbüchern beschrieben zu installieren und zu betreiben. Des Weiteren dürfen auch nur von der IBM empfohlene Kabel angeschlossen werden. IBM übernimmt keine Verantwortung für die Einhaltung der Schutzanforderungen, wenn das Produkt ohne Zustimmung von IBM verändert bzw. wenn Erweiterungskomponenten von Fremdherstellern ohne Empfehlung von IBM gesteckt/eingebaut werden.

Deutschland: Einhaltung des Gesetzes über die elektromagnetische Verträglichkeit von Geräten

Dieses Produkt entspricht dem "Gesetz über die elektromagnetische Verträglichkeit von Geräten (EMVG)". Dies ist die Umsetzung der EU-Richtlinie 2014/30/EU in der Bundesrepublik Deutschland.

Zulassungsbescheinigung laut dem Deutschen Gesetz über die elektromagnetische Verträglichkeit von Geräten (EMVG) (bzw. der EMC Richtlinie 2014/30/EU) für Geräte der Klasse B

Dieses Gerät ist berechtigt, in Übereinstimmung mit dem Deutschen EMVG das EG-Konformitätszeichen - CE - zu führen.

Verantwortlich für die Einhaltung der EMV Vorschriften ist der Hersteller:
International Business Machines Corp.
New Orchard Road
Armonk, New York 10504

Tel: 914-499-1900

Der verantwortliche Ansprechpartner des Herstellers in der EU ist:

IBM Deutschland GmbH
Technical Relations Europe, Abteilung M456
IBM-Allee 1, 71139 Ehningen, Germany
Tel: +49 (0) 800 225 5426
email: HalloIBM@de.ibm.com

Generelle Informationen:

Das Gerät erfüllt die Schutzanforderungen nach EN 55024 und EN 55022/ EN 55032 Klasse B.

Terms and conditions

Permissions for the use of these publications are granted subject to the following terms and conditions.

Applicability: These terms and conditions are in addition to any terms of use for the IBM website.

Personal Use: You may reproduce these publications for your personal, noncommercial use provided that all proprietary notices are preserved. You may not distribute, display or make derivative works of these publications, or any portion thereof, without the express consent of IBM.

Commercial Use: You may reproduce, distribute and display these publications solely within your enterprise provided that all proprietary notices are preserved. You may not make derivative works of these publications, or reproduce, distribute or display these publications or any portion thereof outside your enterprise, without the express consent of IBM.

Rights: Except as expressly granted in this permission, no other permissions, licenses or rights are granted, either express or implied, to the publications or any information, data, software or other intellectual property contained therein.

IBM reserves the right to withdraw the permissions granted herein whenever, in its discretion, the use of the publications is detrimental to its interest or, as determined by IBM, the above instructions are not being properly followed.

You may not download, export or re-export this information except in full compliance with all applicable laws and regulations, including all United States export laws and regulations.

IBM MAKES NO GUARANTEE ABOUT THE CONTENT OF THESE PUBLICATIONS. THE PUBLICATIONS ARE PROVIDED "AS-IS" AND WITHOUT WARRANTY OF ANY KIND, EITHER EXPRESSED OR IMPLIED, INCLUDING BUT NOT LIMITED TO IMPLIED WARRANTIES OF MERCHANTABILITY, NON-INFRINGEMENT, AND FITNESS FOR A PARTICULAR PURPOSE.

