

Power Systems

*Removing and replacing parts in the  
5147-024, ESLL, and ESLS storage  
enclosures*

**IBM**



Power Systems

*Removing and replacing parts in the  
5147-024, ESLL, and ESLS storage  
enclosures*

**IBM**

**Note**

Before using this information and the product it supports, read the information in “Safety notices” on page v, “Notices” on page 17, the *IBM Systems Safety Notices* manual, G229-9054, and the *IBM Environmental Notices and User Guide*, Z125-5823.

This edition applies to IBM Power Systems™ servers that contain the POWER8® processor and to all associated models.

© Copyright IBM Corporation 2016, 2017.

US Government Users Restricted Rights – Use, duplication or disclosure restricted by GSA ADP Schedule Contract with IBM Corp.

---

# Contents

**Safety notices . . . . . v**

**Removing and replacing parts in the 5147-024, ESLL, and ESLS storage enclosures . . . . . 1**

Removing and replacing an enclosure services manager in the 5147-024, ESLL, or ESLS storage enclosure . . . . . 2

Removing and replacing a midplane in the 5147-024, ESLL, or ESLS storage enclosure . . . . . 10

Removing and replacing a power supply in the 5147-024, ESLL, or ESLS storage enclosure . . . . . 14

**Notices . . . . . 17**

Accessibility features for IBM Power Systems servers . . . . . 18

Privacy policy considerations . . . . . 19

Trademarks . . . . . 20

Electronic emission notices . . . . . 20

    Class A Notices . . . . . 20

    Class B Notices . . . . . 24

Terms and conditions . . . . . 27



---

## Safety notices

Safety notices may be printed throughout this guide:

- **DANGER** notices call attention to a situation that is potentially lethal or extremely hazardous to people.
- **CAUTION** notices call attention to a situation that is potentially hazardous to people because of some existing condition.
- **Attention** notices call attention to the possibility of damage to a program, device, system, or data.

### World Trade safety information

Several countries require the safety information contained in product publications to be presented in their national languages. If this requirement applies to your country, safety information documentation is included in the publications package (such as in printed documentation, on DVD, or as part of the product) shipped with the product. The documentation contains the safety information in your national language with references to the U.S. English source. Before using a U.S. English publication to install, operate, or service this product, you must first become familiar with the related safety information documentation. You should also refer to the safety information documentation any time you do not clearly understand any safety information in the U.S. English publications.

Replacement or additional copies of safety information documentation can be obtained by calling the IBM Hotline at 1-800-300-8751.

### German safety information

Das Produkt ist nicht für den Einsatz an Bildschirmarbeitsplätzen im Sinne § 2 der Bildschirmarbeitsverordnung geeignet.

### Laser safety information

IBM® servers can use I/O cards or features that are fiber-optic based and that utilize lasers or LEDs.

#### Laser compliance

IBM servers may be installed inside or outside of an IT equipment rack.

**DANGER:** When working on or around the system, observe the following precautions:

Electrical voltage and current from power, telephone, and communication cables are hazardous. To avoid a shock hazard:

- If IBM supplied the power cord(s), connect power to this unit only with the IBM provided power cord. Do not use the IBM provided power cord for any other product.
- Do not open or service any power supply assembly.
- Do not connect or disconnect any cables or perform installation, maintenance, or reconfiguration of this product during an electrical storm.
- The product might be equipped with multiple power cords. To remove all hazardous voltages, disconnect all power cords.
  - For AC power, disconnect all power cords from their AC power source.
  - For racks with a DC power distribution panel (PDP), disconnect the customer's DC power source to the PDP.
- When connecting power to the product ensure all power cables are properly connected.

- For racks with AC power, connect all power cords to a properly wired and grounded electrical outlet. Ensure that the outlet supplies proper voltage and phase rotation according to the system rating plate.
- For racks with a DC power distribution panel (PDP), connect the customer's DC power source to the PDP. Ensure that the proper polarity is used when attaching the DC power and DC power return wiring.
- Connect any equipment that will be attached to this product to properly wired outlets.
- When possible, use one hand only to connect or disconnect signal cables.
- Never turn on any equipment when there is evidence of fire, water, or structural damage.
- Do not attempt to switch on power to the machine until all possible unsafe conditions are corrected.
- Assume that an electrical safety hazard is present. Perform all continuity, grounding, and power checks specified during the subsystem installation procedures to ensure that the machine meets safety requirements.
- Do not continue with the inspection if any unsafe conditions are present.
- Before you open the device covers, unless instructed otherwise in the installation and configuration procedures: Disconnect the attached AC power cords, turn off the applicable circuit breakers located in the rack power distribution panel (PDP), and disconnect any telecommunications systems, networks, and modems.

**DANGER:**

- Connect and disconnect cables as described in the following procedures when installing, moving, or opening covers on this product or attached devices.

To Disconnect:

1. Turn off everything (unless instructed otherwise).
2. For AC power, remove the power cords from the outlets.
3. For racks with a DC power distribution panel (PDP), turn off the circuit breakers located in the PDP and remove the power from the Customer's DC power source.
4. Remove the signal cables from the connectors.
5. Remove all cables from the devices.

To Connect:

1. Turn off everything (unless instructed otherwise).
2. Attach all cables to the devices.
3. Attach the signal cables to the connectors.
4. For AC power, attach the power cords to the outlets.
5. For racks with a DC power distribution panel (PDP), restore the power from the Customer's DC power source and turn on the circuit breakers located in the PDP.
6. Turn on the devices.

Sharp edges, corners and joints may be present in and around the system. Use care when handling equipment to avoid cuts, scrapes and pinching. (D005)

**(R001 part 1 of 2):**

**DANGER:** Observe the following precautions when working on or around your IT rack system:

- Heavy equipment—personal injury or equipment damage might result if mishandled.
- Always lower the leveling pads on the rack cabinet.
- Always install stabilizer brackets on the rack cabinet.
- To avoid hazardous conditions due to uneven mechanical loading, always install the heaviest devices in the bottom of the rack cabinet. Always install servers and optional devices starting from the bottom of the rack cabinet.
- Rack-mounted devices are not to be used as shelves or work spaces. Do not place objects on top of rack-mounted devices. In addition, do not lean on rack mounted devices and do not use them to stabilize your body position (for example, when working from a ladder).





- Each rack cabinet might have more than one power cord.
  - For AC powered racks, be sure to disconnect all power cords in the rack cabinet when directed to disconnect power during servicing.
  - For racks with a DC power distribution panel (PDP), turn off the circuit breaker that controls the power to the system unit(s), or disconnect the customer's DC power source, when directed to disconnect power during servicing.
- Connect all devices installed in a rack cabinet to power devices installed in the same rack cabinet. Do not plug a power cord from a device installed in one rack cabinet into a power device installed in a different rack cabinet.
- An electrical outlet that is not correctly wired could place hazardous voltage on the metal parts of the system or the devices that attach to the system. It is the responsibility of the customer to ensure that the outlet is correctly wired and grounded to prevent an electrical shock.

**(R001 part 2 of 2):**

**CAUTION:**

- Do not install a unit in a rack where the internal rack ambient temperatures will exceed the manufacturer's recommended ambient temperature for all your rack-mounted devices.
- Do not install a unit in a rack where the air flow is compromised. Ensure that air flow is not blocked or reduced on any side, front, or back of a unit used for air flow through the unit.
- Consideration should be given to the connection of the equipment to the supply circuit so that overloading of the circuits does not compromise the supply wiring or overcurrent protection. To provide the correct power connection to a rack, refer to the rating labels located on the equipment in the rack to determine the total power requirement of the supply circuit.
- *(For sliding drawers.)* Do not pull out or install any drawer or feature if the rack stabilizer brackets are not attached to the rack. Do not pull out more than one drawer at a time. The rack might become unstable if you pull out more than one drawer at a time.



- *(For fixed drawers.)* This drawer is a fixed drawer and must not be moved for servicing unless specified by the manufacturer. Attempting to move the drawer partially or completely out of the rack might cause the rack to become unstable or cause the drawer to fall out of the rack.

**CAUTION:**

Removing components from the upper positions in the rack cabinet improves rack stability during relocation. Follow these general guidelines whenever you relocate a populated rack cabinet within a room or building.

- Reduce the weight of the rack cabinet by removing equipment starting at the top of the rack cabinet. When possible, restore the rack cabinet to the configuration of the rack cabinet as you received it. If this configuration is not known, you must observe the following precautions:
  - Remove all devices in the 32U position (compliance ID RACK-001 or 22U (compliance ID RR001) and above.
  - Ensure that the heaviest devices are installed in the bottom of the rack cabinet.
  - Ensure that there are little-to-no empty U-levels between devices installed in the rack cabinet below the 32U (compliance ID RACK-001 or 22U (compliance ID RR001) level, unless the received configuration specifically allowed it.
- If the rack cabinet you are relocating is part of a suite of rack cabinets, detach the rack cabinet from the suite.
- If the rack cabinet you are relocating was supplied with removable outriggers they must be reinstalled before the cabinet is relocated.
- Inspect the route that you plan to take to eliminate potential hazards.
- Verify that the route that you choose can support the weight of the loaded rack cabinet. Refer to the documentation that comes with your rack cabinet for the weight of a loaded rack cabinet.
- Verify that all door openings are at least 760 x 230 mm (30 x 80 in.).
- Ensure that all devices, shelves, drawers, doors, and cables are secure.
- Ensure that the four leveling pads are raised to their highest position.
- Ensure that there is no stabilizer bracket installed on the rack cabinet during movement.
- Do not use a ramp inclined at more than 10 degrees.
- When the rack cabinet is in the new location, complete the following steps:
  - Lower the four leveling pads.
  - Install stabilizer brackets on the rack cabinet.
  - If you removed any devices from the rack cabinet, repopulate the rack cabinet from the lowest position to the highest position.
- If a long-distance relocation is required, restore the rack cabinet to the configuration of the rack cabinet as you received it. Pack the rack cabinet in the original packaging material, or equivalent. Also lower the leveling pads to raise the casters off of the pallet and bolt the rack cabinet to the pallet.

(R002)

(L001)



**DANGER:** Hazardous voltage, current, or energy levels are present inside any component that has this label attached. Do not open any cover or barrier that contains this label. (L001)

(L002)



**DANGER:** Rack-mounted devices are not to be used as shelves or work spaces. (L002)

(L003)

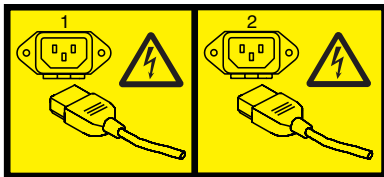

or

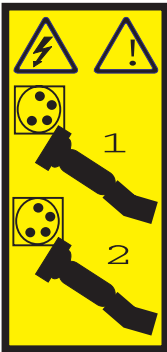

or



or

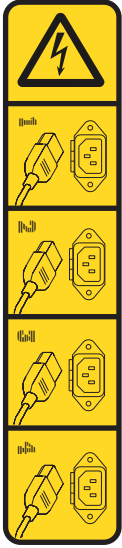

or

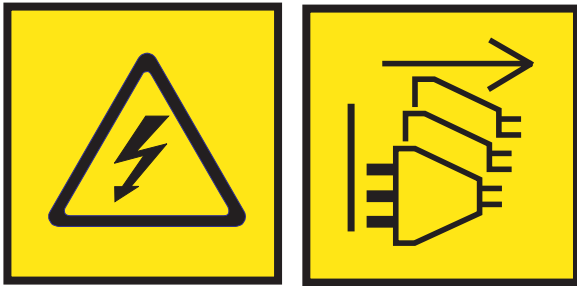

**DANGER:** Multiple power cords. The product might be equipped with multiple AC power cords or multiple DC power cables. To remove all hazardous voltages, disconnect all power cords and power cables. (L003)

(L007)



**CAUTION:** A hot surface nearby. (L007)

(L008)



**CAUTION:** Hazardous moving parts nearby. (L008)

All lasers are certified in the U.S. to conform to the requirements of DHHS 21 CFR Subchapter J for class 1 laser products. Outside the U.S., they are certified to be in compliance with IEC 60825 as a class 1 laser product. Consult the label on each part for laser certification numbers and approval information.

**CAUTION:**

This product might contain one or more of the following devices: CD-ROM drive, DVD-ROM drive, DVD-RAM drive, or laser module, which are Class 1 laser products. Note the following information:

- Do not remove the covers. Removing the covers of the laser product could result in exposure to hazardous laser radiation. There are no serviceable parts inside the device.
- Use of the controls or adjustments or performance of procedures other than those specified herein might result in hazardous radiation exposure.

(C026)

**CAUTION:**

Data processing environments can contain equipment transmitting on system links with laser modules that operate at greater than Class 1 power levels. For this reason, never look into the end of an optical fiber cable or open receptacle. Although shining light into one end and looking into the other end of a disconnected optical fiber to verify the continuity of optic fibers may not injure the eye, this procedure is potentially dangerous. Therefore, verifying the continuity of optical fibers by shining light into one end and looking at the other end is not recommended. To verify continuity of a fiber optic cable, use an optical light source and power meter. (C027)

**CAUTION:**

This product contains a Class 1M laser. Do not view directly with optical instruments. (C028)

**CAUTION:**

Some laser products contain an embedded Class 3A or Class 3B laser diode. Note the following information: laser radiation when open. Do not stare into the beam, do not view directly with optical instruments, and avoid direct exposure to the beam. (C030)

**CAUTION:**

The battery contains lithium. To avoid possible explosion, do not burn or charge the battery.

*Do Not:*

- \_\_\_ Throw or immerse into water
- \_\_\_ Heat to more than 100°C (212°F)
- \_\_\_ Repair or disassemble

Exchange only with the IBM-approved part. Recycle or discard the battery as instructed by local regulations. In the United States, IBM has a process for the collection of this battery. For information, call 1-800-426-4333. Have the IBM part number for the battery unit available when you call. (C003)

## CAUTION:

Regarding IBM provided VENDOR LIFT TOOL:

- Operation of LIFT TOOL by authorized personnel only.
- LIFT TOOL intended for use to assist, lift, install, remove units (load) up into rack elevations. It is not to be used loaded transporting over major ramps nor as a replacement for such designated tools like pallet jacks, walkies, fork trucks and such related relocation practices. When this is not practicable, specially trained persons or services must be used (for instance, riggers or movers).
- Read and completely understand the contents of LIFT TOOL operator's manual before using. Failure to read, understand, obey safety rules, and follow instructions may result in property damage and/or personal injury. If there are questions, contact the vendor's service and support. Local paper manual must remain with machine in provided storage sleeve area. Latest revision manual available on vendor's web site.
- Test verify stabilizer brake function before each use. Do not over-force moving or rolling the LIFT TOOL with stabilizer brake engaged.
- Do not move LIFT TOOL while platform is raised, except for minor positioning.
- Do not exceed rated load capacity. See LOAD CAPACITY CHART regarding maximum loads at center versus edge of extended platform.
- Only raise load if properly centered on platform. Do not place more than 200 lb (91 kg) on edge of sliding platform shelf also considering the load's center of mass/gravity (CoG).
- Do not corner load the platform tilt riser accessory option. Secure platform riser tilt option to main shelf in all four (4x) locations with provided hardware only, prior to use. Load objects are designed to slide on/off smooth platforms without appreciable force, so take care not to push or lean. Keep riser tilt option flat at all times except for final minor adjustment when needed.
- Do not stand under overhanging load.
- Do not use on uneven surface, incline or decline (major ramps).
- Do not stack loads.
- Do not operate while under the influence of drugs or alcohol.
- Do not support ladder against LIFT TOOL.
- Tipping hazard. Do not push or lean against load with raised platform.
- Do not use as a personnel lifting platform or step. No riders.
- Do not stand on any part of lift. Not a step.
- Do not climb on mast.
- Do not operate a damaged or malfunctioning LIFT TOOL machine.
- Crush and pinch point hazard below platform. Only lower load in areas clear of personnel and obstructions. Keep hands and feet clear during operation.
- No Forks. Never lift or move bare LIFT TOOL MACHINE with pallet truck, jack or fork lift.
- Mast extends higher than platform. Be aware of ceiling height, cable trays, sprinklers, lights, and other overhead objects.
- Do not leave LIFT TOOL machine unattended with an elevated load.
- Watch and keep hands, fingers, and clothing clear when equipment is in motion.
- Turn Winch with hand power only. If winch handle cannot be cranked easily with one hand, it is probably over-loaded. Do not continue to turn winch past top or bottom of platform travel. Excessive unwinding will detach handle and damage cable. Always hold handle when lowering, unwinding. Always assure self that winch is holding load before releasing winch handle.
- A winch accident could cause serious injury. Not for moving humans. Make certain clicking sound is heard as the equipment is being raised. Be sure winch is locked in position before releasing handle. Read instruction page before operating this winch. Never allow winch to unwind freely. Freewheeling will cause uneven cable wrapping around winch drum, damage cable, and may cause serious injury. (C048)

## **Power and cabling information for NEBS (Network Equipment-Building System) GR-1089-CORE**

The following comments apply to the IBM servers that have been designated as conforming to NEBS (Network Equipment-Building System) GR-1089-CORE:

The equipment is suitable for installation in the following:

- Network telecommunications facilities
- Locations where the NEC (National Electrical Code) applies

The intrabuilding ports of this equipment are suitable for connection to intrabuilding or unexposed wiring or cabling only. The intrabuilding ports of this equipment *must not* be metalically connected to the interfaces that connect to the OSP (outside plant) or its wiring. These interfaces are designed for use as intrabuilding interfaces only (Type 2 or Type 4 ports as described in GR-1089-CORE) and require isolation from the exposed OSP cabling. The addition of primary protectors is not sufficient protection to connect these interfaces metalically to OSP wiring.

**Note:** All Ethernet cables must be shielded and grounded at both ends.

The ac-powered system does not require the use of an external surge protection device (SPD).

The dc-powered system employs an isolated DC return (DC-I) design. The DC battery return terminal *shall not* be connected to the chassis or frame ground.

The dc-powered system is intended to be installed in a common bonding network (CBN) as described in GR-1089-CORE.





---

## Removing and replacing parts in the 5147-024, ESLL, and ESLS storage enclosures

Use the removing and replacing parts procedures when you repair, maintain, or exchange your system parts.

Before you begin a replacement, complete these tasks:

1. If you are completing a replacement procedure that might put your data at risk, ensure, if possible, that you have a current backup of your system or logical partition (including operating systems, licensed programs, and data).
2. Review the installation or replacement procedure for the feature or part.
3. Note the significance of color on your system.  
*Blue* or *terracotta* on a part of the hardware indicates a touch point where you can grip the hardware to remove it from or install it in the system, open, or close a latch. *Terracotta* might also indicate that the part can be removed and replaced with the system or logical partition power-on.
4. Ensure that you have access to a Phillips screwdriver and a straight-slot screwdriver.
5. If parts are incorrect, missing, or visibly damaged, contact your service provider or next level of support.

**DANGER:** When working on or around the system, observe the following precautions:

Electrical voltage and current from power, telephone, and communication cables are hazardous. To avoid a shock hazard:

- If IBM supplied the power cord(s), connect power to this unit only with the IBM provided power cord. Do not use the IBM provided power cord for any other product.
- Do not open or service any power supply assembly.
- Do not connect or disconnect any cables or perform installation, maintenance, or reconfiguration of this product during an electrical storm.
- The product might be equipped with multiple power cords. To remove all hazardous voltages, disconnect all power cords.
  - For AC power, disconnect all power cords from their AC power source.
  - For racks with a DC power distribution panel (PDP), disconnect the customer's DC power source to the PDP.
- When connecting power to the product ensure all power cables are properly connected.
  - For racks with AC power, connect all power cords to a properly wired and grounded electrical outlet. Ensure that the outlet supplies proper voltage and phase rotation according to the system rating plate.
  - For racks with a DC power distribution panel (PDP), connect the customer's DC power source to the PDP. Ensure that the proper polarity is used when attaching the DC power and DC power return wiring.
- Connect any equipment that will be attached to this product to properly wired outlets.
- When possible, use one hand only to connect or disconnect signal cables.
- Never turn on any equipment when there is evidence of fire, water, or structural damage.
- Do not attempt to switch on power to the machine until all possible unsafe conditions are corrected.
- Assume that an electrical safety hazard is present. Perform all continuity, grounding, and power checks specified during the subsystem installation procedures to ensure that the machine meets safety requirements.
- Do not continue with the inspection if any unsafe conditions are present.

- Before you open the device covers, unless instructed otherwise in the installation and configuration procedures: Disconnect the attached AC power cords, turn off the applicable circuit breakers located in the rack power distribution panel (PDP), and disconnect any telecommunications systems, networks, and modems.

**DANGER:**

- Connect and disconnect cables as described in the following procedures when installing, moving, or opening covers on this product or attached devices.

To Disconnect:

1. Turn off everything (unless instructed otherwise).
2. For AC power, remove the power cords from the outlets.
3. For racks with a DC power distribution panel (PDP), turn off the circuit breakers located in the PDP and remove the power from the Customer's DC power source.
4. Remove the signal cables from the connectors.
5. Remove all cables from the devices.

To Connect:

1. Turn off everything (unless instructed otherwise).
2. Attach all cables to the devices.
3. Attach the signal cables to the connectors.
4. For AC power, attach the power cords to the outlets.
5. For racks with a DC power distribution panel (PDP), restore the power from the Customer's DC power source and turn on the circuit breakers located in the PDP.
6. Turn on the devices.

Sharp edges, corners and joints may be present in and around the system. Use care when handling equipment to avoid cuts, scrapes and pinching. (D005)

**Attention:** Failure to follow the steps sequentially for field replaceable unit (FRU) removal or installation might result in FRU or system damage.

Use the following precautions whenever you handle electronic components or cables:

- The electrostatic discharge (ESD) kit and the ESD wrist strap must be used when you are handling logic cards, single chip modules (SCMs), multiple chip modules (MCMs), electronic boards, and disk drives.
- Keep all electronic components in the shipping container or envelope until you are ready to install them.
- If you remove and reinstall an electronic component, temporarily place the component on an ESD pad or blanket.

---

## Removing and replacing an enclosure services manager in the 5147-024, ESLL, or ESLS storage enclosure

Learn how to remove and replace an enclosure services manager (ESM) in the 5147-024, ESLL, or ESLS storage enclosure.

### About this task

**Attention:** Failure to follow the steps sequentially for this field replaceable unit (FRU) removal or installation might result in damage to the FRU or system.

Use the following precautions whenever you handle electronic components or cables:

- Attach a wrist strap to an unpainted metal surface of your hardware to prevent electrostatic discharge (ESD) from damaging your hardware.

- If you do not have a wrist strap, before you remove the product from ESD packaging and installing or replacing hardware, touch an unpainted metal surface of the system for a minimum of 5 seconds.
- Keep all electronic components in the shipping container or envelope until you are ready to install them.
- If you remove and reinstall an electronic component, temporarily place the component on an ESD pad or blanket, if available.
- During replacement with the system power turned off, do not combine the replacement of any ESM with the replacement of the midplane unless you cycled the power of the storage enclosure. You must replace only one new part at a time when the system power is off. If multiple parts are replaced at the same time when the system power is off, the serial number is not preserved.

**Note:** To prevent the loss of enclosure information, do not replace both ESMs at the same time with the storage enclosure power turned off. To replace the second ESM when the storage enclosure power is turned off, replace the first ESM, then restore storage enclosure power. Wait three minutes. Then turn the storage enclosure power off the replace the second ESM.

## Procedure

1. Determine whether the repair operation can continue when the system power is turned on. To continue the repair operation when the system power is turned on, the following conditions must be true:
  - A second ESM must already be installed and the amber LED on the second ESM is not turned on.
  - The amber fault light of the failing ESM is turned on solid, or you are using one of the following operating systems:
    - AIX® release 7.2.2 or later, and the controlling adapters have a code level of 17518200 or higher.
    - IBM i with a minimum of V7R3 with MF99204 (TR4), or V7R2 with MF99108 (TR8), and the controlling adapters have PTF MF64136 for V7R3 or MF64117 for V7R2, or higher applied.
2. If these conditions are false, continue the repair operation only after you power off the system that is hosting the enclosure that contains the part that is being repaired.

Option	Description
Either condition is false. You must perform the repair operation with the system power turned off.	<ol style="list-style-type: none"> <li>1. Power off the system or partition that is hosting the storage enclosure.</li> <li>2. Label and remove the power cords from both power supplies of the storage enclosure.</li> <li>3. Proceed to step 15 on page 7.</li> </ol> <p><b>Note:</b> To prevent the loss of enclosure information, do not replace both ESMs at the same time with the storage enclosure power turned off. To replace the second ESM when the storage enclosure power is turned off, replace the first ESM, then restore storage enclosure power. Wait three minutes. Then turn the storage enclosure power off the replace the second ESM.</p>
Both conditions are true. You can perform the repair operation with the system power turned on.	Proceed to step 3.

3. Choose from the following options:
  - If the amber fault light of the failing ESM is turned on solid, continue with step 15 on page 7.
  - If the amber fault light of the failing ESM is not turned on solid and if you are using the AIX operating system to replace the part, continue with step 4 on page 4.
  - If the amber fault light of the failing ESM is not turned on solid and if you are using the IBM i operating system to replace the part, continue with step 8 on page 5.

4. If you are using the AIX operating system, complete the following steps to prepare the ESM for removal:
  - a. Log in to the AIX operating system as root user, or CE login.
  - b. Enter the diag command to load the diagnostic controller, and to display the online diagnostic menu options.
  - c. If requested, enter a password.
  - d. When the Diagnostic Operating Instructions screen is shown, press Enter.
  - e. From the **Function Selection** menu, select **Task Selection > Display Previous Diagnostic Results > Display Diagnostic Log Summary**. A chronological list of events is shown.
  - f. Review the T column for the most recent S entry for the ESM (logical SES device and resource name that has the sesX) that you are servicing.
  - g. Select the row with the most recent S entry in the table and press Enter.
  - h. Select **Commit**. The details of this log entry are shown.
  - i. Record the sesX resource name and the location code of the failing ESM.
  - j. Press **F3** or **Esc+3** three times to return to the Tasks Selection lists.

**Attention:** The ESM to be swapped may be attached to multiple SAS controllers. These SAS controllers may be in the same partition, or split between multiple partitions on the same or separate systems. The configuration and location of all SAS controllers attached to this ESM must be understood to safely remove it. The customer may have to provide this configuration information.

**Attention:** The ESM may be partitioned in a mode that this service procedure does not support. The partitioning mode of the ESM can be found on a label on the rear of the storage inclosure and can also be displayed in the sesX device's Vital Product Data.

- k. In the Task Selection list, scroll down to **Display Hardware Vital Product Data** and press **Enter**.
- l. In the Resource Selection List, scroll down to the sesX device recorded in step 4i. Select it using the Enter key, then press F7 to commit. A sample VPD is shown as follows:

```

Display Vital Product Data (VPD)
ses2          UESLS.001.G63X003-P1-C2  SAS Enclosure Services Device
  SAS Expander:
    FRU Number.....01DH720
    Serial Number.....YL30nnnnnnnnn
    Customer Card ID Number....xxxx
    Product Specific.(ZM).....2
    Load ID.....A17nnnnn
    ROM Level.(alterable).....41C0
    Hardware Location Code.....UESLS.001.G63X003-P1-C2

PLATFORM SPECIFIC

Name: disk
Node: disk
Device Type: block

To continue, press Enter.

Esc+3=Cancel      F10=Exit      Enter
  
```

The value in the "Product Specific.(ZM)" field is the ESM partitioning mode. If this value is 4, this procedure must be done with enclosure storage power off. If this value is 1 or 2, there may be SAS adapters in other partitions or systems; in this case, the customer will have to provide configuration information.

- m. Press **F3** or **Esc+3** three times to return to the Tasks Selection lists.
5. Use the AIX diagnostics to identify the ESM to be removed:
    - a. Page down and select **Identify and Attention Indicators**.

- b. Page down and select the location code that was recorded in step 4i on page 4. Press Enter, then press **F7** to turn the indicators on.

The blue identify LEDs on the drawer and both ESMs turn blue, the amber fault LED flashes on the selected ESM (at the rear of the enclosure).

- c. View the LEDs to locate the ESM that must be replaced.

**Notes:**

- Ensure that the correct ESM is selected and that the fault LED on the other ESM in the same storage enclosure is not turned on solid.
- If the correct ESM is selected, but the other ESM in the same storage enclosure has a fault LED turned on solid, the procedure must be completed when the system power is turned off. Return to step 2 on page 3 to complete the procedure with the system power turned off.

- d. Press **F3** or **Esc+3** to return to the Tasks Selection list.

6. Suspend the ESM by using the AIX operating system:

- a. From the Tasks Selection list, select **Hot Plug Task > Expander Suspend and Resume Manager**.

- b. Select the sesX entry with the location code of the ESM that you are replacing and press Enter.

A warning message is shown. Select **Yes** and press Enter. The sesX device is suspended. If the sesX device is in mode 2, there is a second entry with the same location code but a different sesX device number; suspend that device as well.

- c. If you have a dual adapter configuration, repeat step 6b for the other adapter.

**Attention:** The other adapter may be in another partition or another system.

- d. Ensure that all of the sesX devices show a status of **Suspended** (in both of the adapter resources if this is a dual controller configuration). Note the sesX device names of the suspended devices.

- e. Press **F3** or **Esc+3** to return to the Tasks Selection list.

- f. Select **Hot Plug Task > PCI Hot Plug Manager > Unconfigure a Device**.

- g. Enter the sesX device in the device name field. Press the Down Arrow key to move to **Unconfigure any Child Devices**, then press the Tab key to change the value to **yes**. Press Enter perform the operation. A sasdrawerX device may also be unconfigured. Repeat this step for all of the sesX devices noted in step 6d.

7. Continue with step 15 on page 7 to remove the ESM.

8. Use the **IBM i operating system** to determine the location of the ESM assembly in the storage enclosure by completing steps 9 - 14 on page 7.

**Note:** You might want to print this procedure to record the information that you gather during this procedure in Table 1, or you can use a separate paper.

Table 1. Resource names of the ESM, IOAs, and system bus numbers

Path	1	2
Resource names of ESM to be replaced (step 10c on page 6)	Dxx	Dxx
System Bus Number in decimal (recorded in step 10d on page 6)	xxx	xxx
Resource Names of the IOAs that are attached to the ESM (recorded in step 12d on page 6)	DCxx	DCxx
IOA Operating Mode (recorded in step 12g on page 6) <b>Note:</b> Only valid in dual adapter configurations.	Secondary	Primary

9. Start the IBM i Hardware service manager:

- a. On the command line of the main menu, type **strsst** and press Enter.
  - b. Type the service tools user ID and password and press Enter.
  - c. Select **Start a service tool > Hardware service manager**.
10. Determine the resource name and system bus number of the ESM to be replaced by using the IBM i Hardware service manager:
- a. Select **Packaging hardware resources (system, frames, cards) > Hardware contained within package** for the storage enclosure that contains the part you want to replace.
  - b. Select **Associated logical resources** for the Device Services (ESM) that contains the location of the ESM to be replaced.
  - c. For each Device Services Logical Resource shown, record the resource name and status of the Device Services (ESM). This resource represents the ESM to be replaced. The device service can show a status other than Operational. See Table 1 on page 5 for an example table of what you need to record. A second column is included in the table for dual adapter configurations.
  - d. When **Detail** is displayed on each Device Services Logical Resources, record the System bus number of each device.
  - e. Use the **Cancel** key to return to the Packaging Hardware Resources window for the storage enclosure that you selected.
11. Check that the redundant ESM is operational by checking the resource names and status of the redundant ESM by using the IBM i operating system:
- a. Select **Associated logical resources** for the other (redundant) Device Services (ESM).
  - b. Check the status of each Device Services (ESM) shown. Each resource represents the redundant ESM. Verify that each of these Device Services has a status of Operational. If the status or statuses are not Operational, this procedure cannot be completed when the system power is turned on.
  - c. When **Detail** is displayed on each resource name, record the System Bus number of each device. These bus numbers must match the bus numbers that were recorded in step 10d. Use the **Cancel** function to return to the Logical Resources Associated with a Packaging Resource screen.
  - d. Press **Exit** to return to the **Hardware Service Manager** menu.
12. Determine the resource names of the IOAs to which the ESM is attached by using the IBM i operating system:
- a. Select **Logical hardware resources (buses, IOPs, controllers) > System bus resources**.
  - b. In the System buses to work with field, enter the first bus number that you recorded in step 10d and press Enter. The results that are shown are for the bus number that you entered.
  - c. Select **Resources associated with IOP** for the Virtual IOP listed.
  - d. Find the storage IOA with a resource name similar to "DCxx" and select **Display detail**. Record the **Resource name** associated with the bus number you entered in step 12b. See Table 1 on page 5.
  - e. Choose from the following options:
    - If you have a single adapter configuration, you can suspend the ESM. Continue with step 13.
    - If you have a dual adapter configuration, repeat steps 12b - 12d for the other adapter. Then, continue with 12f.
  - f. On the Auxiliary Storage Hardware Resource Detail screen, select the function for **Dual Storage IOA Configuration**. Two IOAs should be listed on the display.
  - g. For each listed IOA, record the **operating mode** and verify that the status is Operational.
- Note:** If the status of both IOAs are not Operational, this procedure must be completed when the system power is turned off. Return to step 2 on page 3 to complete the procedure with system power turned off.
- h. Select **Exit** twice to return to the SST display.
13. Suspend the ESM that you want to replace by using the IBM i operating system:

- a. Select **Start a service tool > Display/Alter/Dump > Display/Alter storage > Licensed Internal Code (LIC) data**.
  - b. Scroll down and select **Advanced analysis**, type 1 in the **Option** field and type IOASES on the command line and press Enter.
  - c. On the Specify Advanced Analysis screen, type the following command:  

```
-ioa xxxx -ses yyy -suspend
```

 where *xxxx* is the resource name of the Primary IOA recorded in step 12d on page 6, and *yyy* is the resource name of the Device Services recorded in step 10c on page 6.
  - d. Review the results:
    - Several Device Services (ESM) devices might be listed because the IOA might have other connections.
    - Only the Device Services (ESM) specified in step 13c must have a status of Suspended. That is, at most one device must be suspended.
    - If success is not indicated, do not continue with removing the ESM when the system power is turned on. Contact your next level of support.  
 If you see code 78D13002 in the product activity log, that is normal and does not indicate a need for further support.
  - e. Record the Serial Number of the Suspended Device Services Resource and press Enter.
  - f. If you have a dual adapter configuration, repeat steps 13c - 13e with the other path you recorded in Table 1 on page 5. If you have a single adapter configuration, continue with step 13h.
  - g. Verify that the Suspended Device Services (ESMs) that were suspended have the same Serial Numbers that you recorded in 13e each time.
  - h. Select **Exit** twice to return to the SST display.
14. Turn on the LEDs to identify the ESM to remove by using the IBM i operating system:
- a. Select **Start a service tool**.
  - b. Select **Hardware service manager > Packaging hardware resources (system, frames, cards)**.
  - c. Select **Hardware contained within package** for the storage enclosure where the ESM is located.
  - d. Select **Associated logical resources** for the Device Services (ESM) that contains the location of the ESM to be replaced and press Enter. Verify that the Device Services (ESM or ESMs) have a status of **Failed**.
  - e. Select **Associated packaging resources** for the Device Services (ESM). If you have a dual adapter configuration, select one of the adapters.
  - f. Select **Concurrent Maintenance** for the ESM Device Services resource.
  - g. Select **Toggle identify indicator state for the resource**.

**Notes:**

- The blue enclosure identify LED at the front and back of the storage enclosure turns on solid to identify the enclosure.
  - A fast-blinking amber LED at the rear of the ESM indicates that the slot is identified.  
 Physically verify that the identified slot is where you want to remove the ESM assembly.
15. Complete the following steps to remove the ESM:
- a. Noting their locations, label and disconnect the serial-attached SCSI (SAS) cables from the ESM.  
**Attention:** Incorrect cable placement might result in data loss.
  - b. Open the two release levers (**A**) as shown in Figure 1 on page 8.
  - c. Support both sides of the ESM while you slide it out of the enclosure.

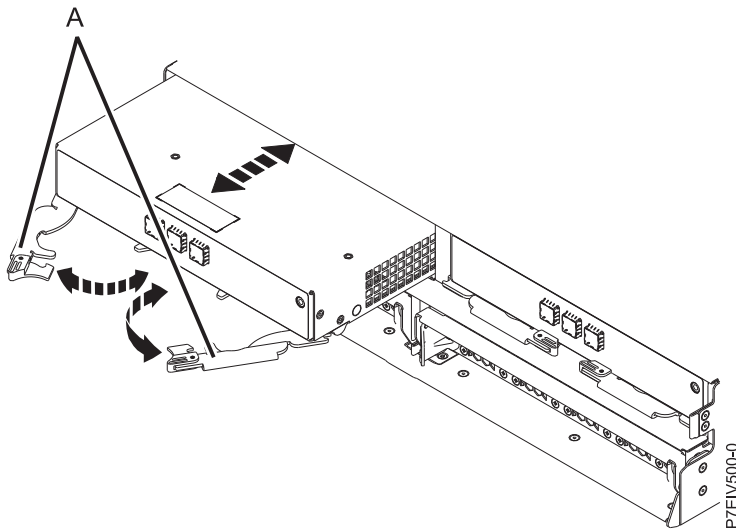

Figure 1. Removing an ESM from the disk drive enclosure

- d. Choose from the following options:
  - If you removed the ESM when the system power was turned off, continue with step 16.
  - If you used the AIX operating system to remove the ESM when the system power was turned on, continue with step 16.
  - If you used the IBM i operating system to remove the ESM when the system power was turned on, select **Exit** twice to return to the SST screen. Then, continue with step 16.
16. To install the ESM, complete the following steps:
  - a. Check that the connector pins at the front of the ESM are not bent and that no pins are damaged.
  - b. Ensure that the release levers on the new ESM are in the open position.
  - c. Slide the ESM gently into the enclosure until the ESM stops.
  - d. Push the release levers to the closed position.
  - e. Remove any SAS protectors from the old ESM and insert them into their corresponding locations in the replacement ESM.
  - f. Reconnect the SAS cables to the ESM by using your labels.
 

**Attention:** Incorrect cable placement might result in data loss.
  - g. Choose from the following options:
    - If you installed the ESM when the system power was turned off, continue with step 17.
    - If you installed the ESM when the system power was turned on and you are using the AIX operating system, continue with step 18.
    - If you installed the ESM when the system power was turned on and you are using the IBM i operating system, continue with step 19 on page 9.
17. If you replaced the part when the system power was turned off, restore power to the power supplies of the storage enclosure and power on the system or partition. **This ends the procedure.**
18. If you replaced the part by using the AIX operating system, complete the following steps:
  - a. From the Tasks Selection list, select **Hot Plug Task**.
 

**Note:** Wait for 1 minute after the LEDs on the newly-installed ESM come on, to ensure that the configuration data is updated.
  - b. Select **PCI Hot Plug Manager > Install/Configure Devices Added After IPL**.
  - c. Press **Enter** on the **Install/Configure Devices Added After IPL** screen. Wait for 1 minute to ensure that the configuration data is updated after the operation is complete.



- d. Press **F3** or **Esc+3** three times to return to the tasks list.
  - e. Select **Hot Plug Task > Expander Suspend and Resume Manager** and complete the following steps:
    - 1) Select the *sesX* entry for the ESM you replaced, and press Enter. Repeat this step for all of the *sesX* devices associated with the location code of the ESM device that were suspended in step 6d on page 5.
    - 2) If you have a dual adapter configuration, select the *sesX* entry under the second adapter and press Enter. Repeat this step for all of the *sesX* devices associated with the location code of the ESM device that were suspended in step 6d on page 5.
    - 3) Ensure that all *sesX* entries show a status of Active.
  - f. Press **F3** or **Esc+3** to return to the Tasks Selection list.
  - g. Scroll down, select **Identify and Attention Indicators**, and press Enter.
  - h. Scroll down to the location code of the ESM that was replaced.
    - If a capital **I** is present, press Enter, then press **F7** to commit and turn off the identify LEDs. Press **F3** or **Esc+3** to return to the Tasks Selection List. **This ends the procedure.**
    - If no capital **I** is present, press **F3** or **Esc+3** to return to the Tasks Selection List. **This ends the procedure.**
19. If you replaced the part by using the IBM i operating system, activate the IOA:
- a. Wait for at least 1 minute.
  - b. From the IBM i SST display, select **Start a service tool > Display/Alter/Dump > Display/Alter storage > Licensed Internal Code (LIC) data**.
  - c. Scroll down and select **Advanced analysis**, type **1** in the **Option** field and type **IOASES** on the command line and press Enter.
  - d. In the Specify Advanced Analysis Options display, type
 

```
-ioa xxxx -ses yyy -resume
```

 where *xxxx* is the resource name of the Primary IOA recorded in step 12g on page 6, and *yyy* is the resource name of the Device Services recorded in step 10c on page 6.
  - e. Review the results of the Advanced Analysis IOA SES invocation.
    - Several Device Services (ESM) devices might be listed because the IOA might have other connections.
    - All Device Services (ESM) resources must show a status of Active.
    - If success is not indicated, contact your next level of support for assistance.
  - f. Press Enter.
  - g. If you have a dual adapter configuration, repeat steps 19b - 19e with the other path that you recorded in Table 1 on page 5. If you have a single adapter configuration, continue with step 19k.
  - h. In the Specify Advanced Analysis Options display, type
 

```
-ioa xxxx -ses yyy -reset
```

 where *xxxx* is the resource name of the Primary IOA recorded in step 12g on page 6, and *yyy* is the resource name of the Device Services recorded in step 10c on page 6.
  - i. Review the results of the Advanced Analysis IOA SES invocation.
    - Several Device Services (ESM) devices might be listed because the IOA might have other connections.
    - All Device Services (ESM) resources must show a status of Active.
    - If success is not indicated, contact your next level of support for assistance.
  - j. Press **Enter**.
  - k. Select **Exit** twice to return to the SST display.

20. To verify that the SES resource is active for each IOA, complete the following steps by using the IBM i operating system:
  - a. From the SST display, select **Start a service tool**.
  - b. Select **Hardware service manager > Logical hardware resources (buses, IOPs, controllers) > System bus resources**.
  - c. In the **System bus(es) to work with** field, enter the first bus number that you recorded in step 10d on page 6 and press Enter. The results that are shown are for the bus number that you entered.
  - d. Select **Resources associated with IOP** for the listed Virtual IOP.
21. Choose from the following options:
  - If you have a single adapter configuration, continue with step 23.
  - If you have a dual adapter configuration, continue with the next step.
22. If you have a dual adapter configuration, complete the following steps by using the IBM i operating system:
  - a. Find the Storage IOA with a resource name such as DCxx and select **Display detail** for that resource.
  - b. On the Detail display, select **Dual Storage IOA Configuration**. Two IOAs are shown.
  - c. For each listed IOA, verify that the status is **Operational**. If the status of both IOAs are not Operational, the procedure might have failed. Contact your next level of support.
  - d. Select **Resources associated with controlling IOP** for the Secondary Storage IOA.
  - e. Find the Device Services (SES) entries that you recorded during the remove procedure. Verify that both devices are operational. If either is not operational, the procedure might have failed. Contact your next level of support.
  - f. Select **Cancel** to return to the previous screen.
  - g. Select **Resources associated with controlling IOP** for the Primary Storage IOA.
23. Find the Device Services (SES) entries that were recorded during the removal procedure. Verify that both IOAs are operational. If either is not operational, the procedure might have failed. Contact your next level of support.
24. Select **Exit** twice to return to the SST display. **This ends the procedure.**

---

## Removing and replacing a midplane in the 5147-024, ESLL, or ESLS storage enclosure

Learn how to remove and replace the midplane in the 5147-024, ESLL, or ESLS storage enclosure.

### About this task

The tools needed to complete this task are a 5 mm flat screwdriver, a Philips #1 screwdriver, and a Philips #2 screwdriver.

**Attention:**

- Failure to follow the steps sequentially for this field replaceable unit (FRU) removal or installation might result in damage to the FRU or system.
- The failed midplane must be replaced only with a new midplane; a midplane cannot be reused from another disk drive enclosure. If the midplane was previously installed in a different disk drive enclosure, the enclosure serial number might not be properly updated during power-on.
- Replace only the midplane FRU in this procedure until power is restored to the disk drive enclosure with the new midplane installed. The original enclosure services managers (ESMs) must be used in this procedure to preserve the serial number.

Use the following precautions whenever you handle electronic components or cables:

- Attach a wrist strap to an unpainted metal surface of your hardware to prevent electrostatic discharge (ESD) from damaging your hardware.
- If you do not have a wrist strap, before you remove the product from ESD packaging and installing or replacing hardware, touch an unpainted metal surface of the system for a minimum of 5 seconds.
- Keep all electronic components in the shipping container or envelope until you are ready to install them.
- If you remove and reinstall an electronic component, temporarily place the component on an ESD pad or blanket, if available.
- During replacement with the system power turned off, do not combine the replacement of any ESM with the replacement of the midplane unless you cycled the power of the storage enclosure. You must replace only one new part at a time when the system power is off. If multiple parts are replaced at the same time when the system power is off, the serial number is not preserved.

**Procedure**

1. Take the storage enclosure offline. This procedure is not concurrent because the power must be removed.
2. To service the midplane, remove the power cords to the disk drive enclosure. Removing the power cords from the disk drive enclosure might require powering off the system or partition that is using the disk drive enclosure.
3. Remove both power supplies from the disk drive enclosure. For instructions, see “Removing and replacing a power supply in the 5147-024, ESLL, or ESLS storage enclosure” on page 14.
4. Carefully remove each disk drive and label it with the slot from which it was removed. For instructions, see Removing a disk drive or solid-state drive ([www.ibm.com/support/knowledgecenter/POWER8/p8hal/p8hal\\_eslx\\_remove\\_poweroff.htm](http://www.ibm.com/support/knowledgecenter/POWER8/p8hal/p8hal_eslx_remove_poweroff.htm))  
After the midplane is replaced, the disk drives must be inserted back into the same slots from which they were removed.
5. Label and remove all SAS cables to the ESMs.
6. Remove both ESMs. For instructions, see “Removing and replacing an enclosure services manager in the 5147-024, ESLL, or ESLS storage enclosure” on page 2.
7. Remove the bezels and unscrew the drawer from the rack.
8. Remove the midplane assembly screws as shown in Figure 2 on page 12. Label the screws with the location from which they are removed.

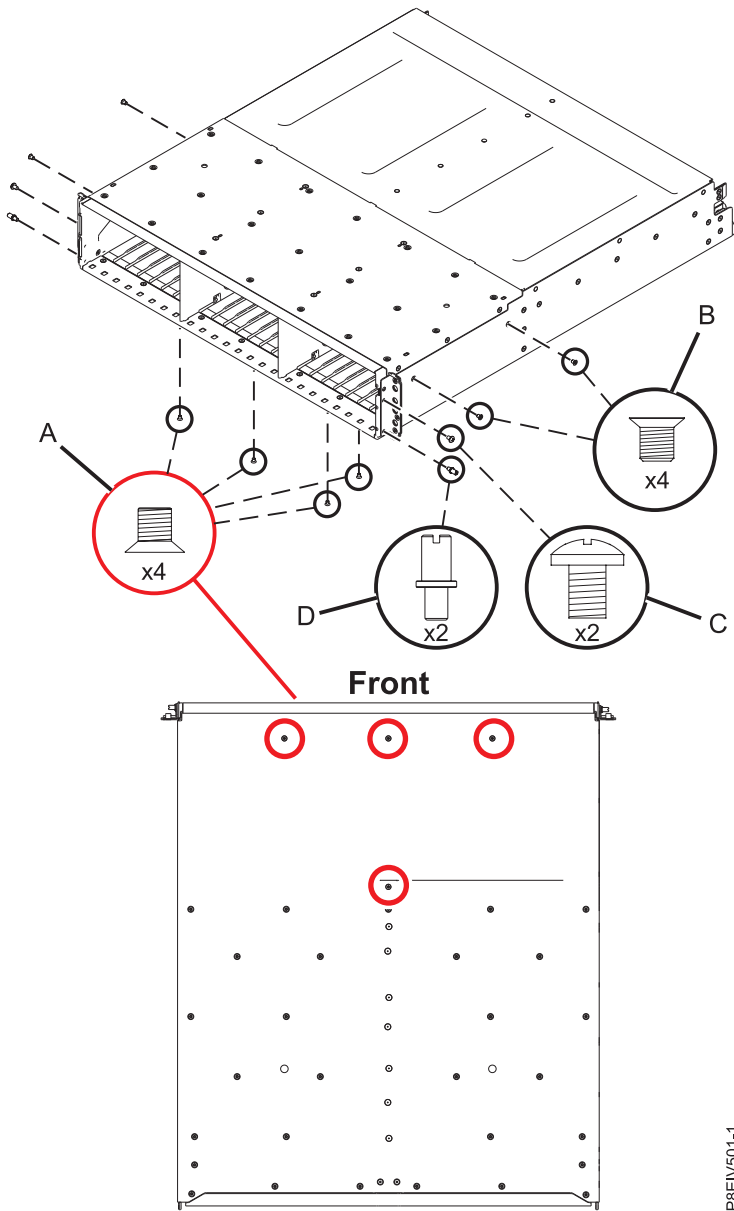
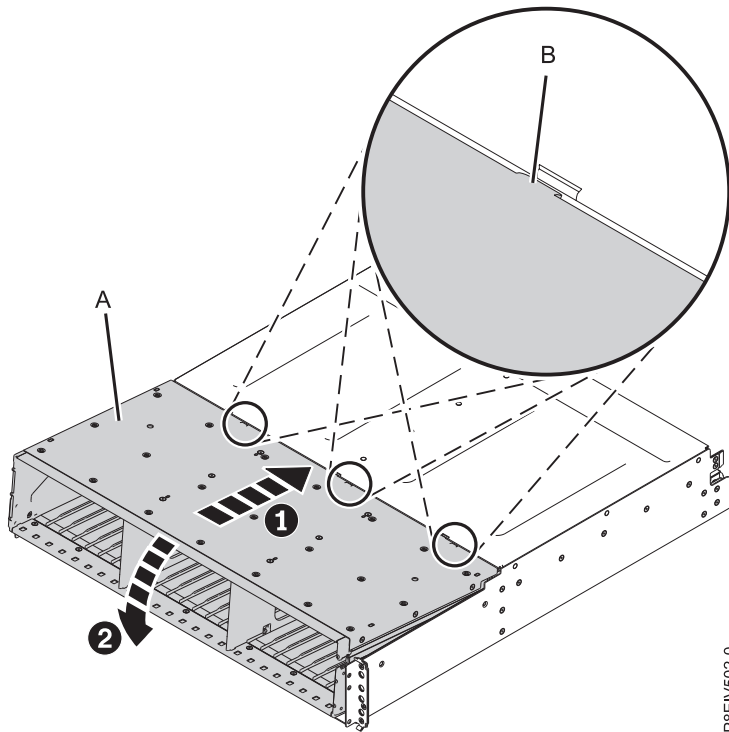

Figure 2. Removing the midplane assembly screws

- a. Remove the enclosure from the rack, turn it upside down, and place the enclosure on a flat surface.
  - b. Using a #1 Phillips screwdriver, remove the four screws (**A**) from the bottom of the enclosure.
  - c. Turn the enclosure top side up and place it on a flat surface. Using a #2 Phillips screwdriver, remove the four screws (**B**) on the right and left sides of the enclosure.
  - d. Remove the four screws on the mounting brackets. Screws at (**C**) use a #2 Phillips screwdriver; screws at (**D**) use a straight-slot screwdriver.
9. Remove the midplane assembly by sliding the assembly straight out of the enclosure.
  10. Install the midplane assembly.
    - a. Grasp the midplane assembly (**A**) with two hands and hold it at a 20-degree angle as shown in Figure 3 on page 13.

- b. Insert the three tabs **(B)** on the midplane assembly into the tab holes in the enclosure. Ensure that the tabs go over the mesh gasket material; do not allow the tabs to catch and crush the mesh.



P8EIV502-0

Figure 3. Midplane assembly installation

- c. Rotate the front of the assembly down. Ensure that the midplane is fully seated into the enclosure.
11. Install the midplane assembly screws. Refer to Figure 2 on page 12.
    - a. Insert four screws **(B)** on both the right and left sides of the enclosure. Insert the screws, but do not fully tighten them now.
    - b. Insert four screws **(C)** and **(D)** at the front of the enclosure. Insert the screws, but do not fully tighten them now.
    - c. Turn the enclosure upside down and use the four screws **(A)** to secure the midplane to the bottom of the enclosure. Securely tighten these bottom screws.
    - d. Turn the enclosure top side up and securely tighten the screws at **(B)**, **(C)**, and **(D)**
    - e. Install the enclosure in the rack.
  12. Screw the drawer into the rack and install bezels.
  13. Install both of the original ESMs. For instructions, see “Removing and replacing an enclosure services manager in the 5147-024, ESSL, or ESLS storage enclosure” on page 2.
  14. Install SAS cables to the ESMs.
  15. Install both original power supplies. For instructions, see “Removing and replacing a power supply in the 5147-024, ESSL, or ESLS storage enclosure” on page 14.
  16. Install the disk drives making sure that each disk drive is inserted back into the same slot from which it was removed. After the midplane is replaced, the disk drives must be inserted back into the same slots from which they were removed. For instructions, see Replacing a disk drive or solid-state drive ([www.ibm.com/support/knowledgecenter/POWER8/p8hal/p8hal\\_eslx\\_replace\\_poweroff.htm](http://www.ibm.com/support/knowledgecenter/POWER8/p8hal/p8hal_eslx_replace_poweroff.htm)).
  17. Restore power to the power supplies of the disk drive enclosure and power on the system or partition.

18. Check the LEDs to make sure that the enclosure is fully operational.

---

## Removing and replacing a power supply in the 5147-024, ESLL, or ESLS storage enclosure

Learn how to remove and replace a power supply in the 5147-024, ESLL, or ESLS storage enclosure.

### About this task

**Attention:** Failure to follow the steps sequentially for this field replaceable unit (FRU) removal or installation might result in damage to the FRU or system.

Use the following precautions whenever you handle electronic components or cables:

- Attach a wrist strap to an unpainted metal surface of your hardware to prevent electrostatic discharge (ESD) from damaging your hardware.
- If you do not have a wrist strap, before you remove the product from ESD packaging and installing or replacing hardware, touch an unpainted metal surface of the system for a minimum of 5 seconds.
- Keep all electronic components in the shipping container or envelope until you are ready to install them.
- If you remove and reinstall an electronic component, temporarily place the component on an ESD pad or blanket, if available.
- During replacement with the system power turned off, do not combine the replacement of any ESM with the replacement of the midplane unless you cycled the power of the storage enclosure. You must replace only one new part at a time when the system power is off. If multiple parts are replaced at the same time when the system power is off, the serial number is not preserved.

### Procedure

1. Determine whether the repair can continue concurrently; that is, with the power turned on. To continue the repair concurrently, the following conditions must be true:
  - A second power supply must already be installed.
  - The second power supply LEDs must be set as follows:
    - The DC power LED (green) is turned on solid.
    - The fault LED (amber) is turned off.
    - The AC power LED (green) is turned on solid.

**Note:** If you decide to remove and replace the failing power supply with the power turned on, the procedure must be completed in less than 6 minutes to prevent overheating.

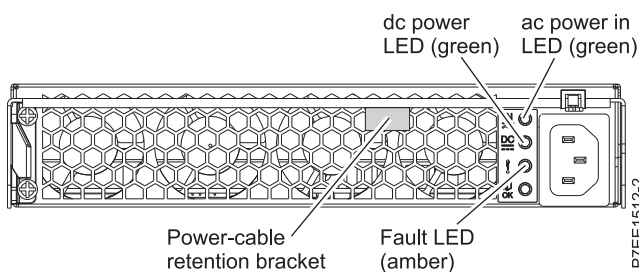

Figure 4. Rear view of the power supply

2. If either of these conditions are false, continue the repair only after you power off the unit that contains the FRU that is being repaired.

Option	Description
<p>Either condition is false. You must do the repair non-concurrently with the power turned off.</p>	<ol style="list-style-type: none"> <li>1. Power off the system or partition that is using the disk drive enclosure.</li> <li>2. Remove the power-cable retention brackets.</li> <li>3. Label and remove the power cables from the power supplies of the disk drive enclosure.</li> <li>4. Proceed to step 3.</li> </ol> <p><b>Note:</b> To prevent loss of enclosure information, do not replace both ESMs at the same time with the power turned off. To replace the second ESM non-concurrently, restore power first. Then, remove power and replace the ESM.</p>
<p>Both conditions are true. You can do the repair concurrently with the power turned on.</p>	<ol style="list-style-type: none"> <li>1. Do not remove power from the working power supply during this procedure.</li> <li>2. Remove the power-cable retention bracket.</li> <li>3. Label and remove the power cable from the power supply to be removed.</li> <li>4. Proceed to step 3.</li> </ol>

3. Remove the power supply.

**Note:** If you are removing the power supply with the power turned on, this operation must be completed within 6 minutes to prevent overheating.

- a. On the left side of the power supply, press the orange release tab to the right, enough to release the handle as you rotate the handle downward.
- b. Using the handle, gently slide the power supply out of the enclosure, supporting the bottom.

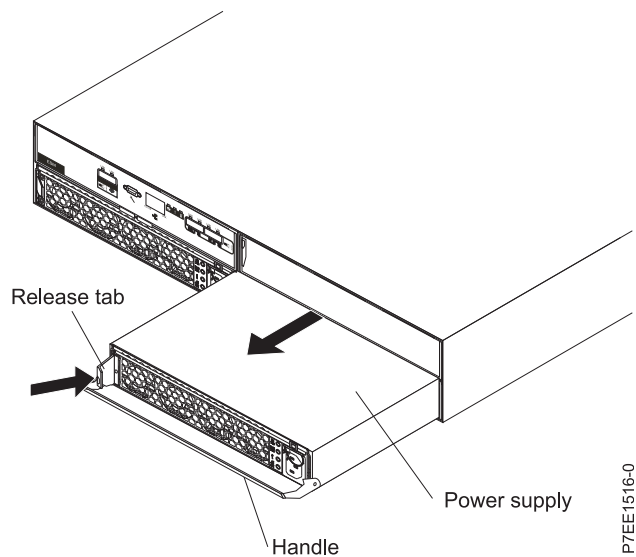

Figure 5. Removing the power supply

4. Install the power supply:

- a. Hold the replacement power supply so that the handle is fully extended downward.
- b. Gently slide the power supply into the enclosure until it stops.
- c. Rotate the handle upward into the closed position until it clicks.
- d. Reconnect the power cable to the power supply. Install the power-cable retention bracket.

**Note:** After the power cord is reconnected, ensure that the AC and DC power (green) LEDs are lit and that the fault (amber) LED is off.

- e. If this service action was a non-concurrent repair, reconnect the power cable to the other power supply, install the power-cable retention bracket, and power on the system or partition.



---

## Notices

This information was developed for products and services offered in the US.

IBM may not offer the products, services, or features discussed in this document in other countries. Consult your local IBM representative for information on the products and services currently available in your area. Any reference to an IBM product, program, or service is not intended to state or imply that only that IBM product, program, or service may be used. Any functionally equivalent product, program, or service that does not infringe any IBM intellectual property right may be used instead. However, it is the user's responsibility to evaluate and verify the operation of any non-IBM product, program, or service.

IBM may have patents or pending patent applications covering subject matter described in this document. The furnishing of this document does not grant you any license to these patents. You can send license inquiries, in writing, to:

*IBM Director of Licensing  
IBM Corporation  
North Castle Drive, MD-NC119  
Armonk, NY 10504-1785  
US*

INTERNATIONAL BUSINESS MACHINES CORPORATION PROVIDES THIS PUBLICATION "AS IS" WITHOUT WARRANTY OF ANY KIND, EITHER EXPRESS OR IMPLIED, INCLUDING, BUT NOT LIMITED TO, THE IMPLIED WARRANTIES OF NON-INFRINGEMENT, MERCHANTABILITY OR FITNESS FOR A PARTICULAR PURPOSE. Some jurisdictions do not allow disclaimer of express or implied warranties in certain transactions, therefore, this statement may not apply to you.

This information could include technical inaccuracies or typographical errors. Changes are periodically made to the information herein; these changes will be incorporated in new editions of the publication. IBM may make improvements and/or changes in the product(s) and/or the program(s) described in this publication at any time without notice.

Any references in this information to non-IBM websites are provided for convenience only and do not in any manner serve as an endorsement of those websites. The materials at those websites are not part of the materials for this IBM product and use of those websites is at your own risk.

IBM may use or distribute any of the information you provide in any way it believes appropriate without incurring any obligation to you.

The performance data and client examples cited are presented for illustrative purposes only. Actual performance results may vary depending on specific configurations and operating conditions.

Information concerning non-IBM products was obtained from the suppliers of those products, their published announcements or other publicly available sources. IBM has not tested those products and cannot confirm the accuracy of performance, compatibility or any other claims related to non-IBM products. Questions on the capabilities of non-IBM products should be addressed to the suppliers of those products.

Statements regarding IBM's future direction or intent are subject to change or withdrawal without notice, and represent goals and objectives only.

All IBM prices shown are IBM's suggested retail prices, are current and are subject to change without notice. Dealer prices may vary.

This information is for planning purposes only. The information herein is subject to change before the products described become available.

This information contains examples of data and reports used in daily business operations. To illustrate them as completely as possible, the examples include the names of individuals, companies, brands, and products. All of these names are fictitious and any similarity to actual people or business enterprises is entirely coincidental.

If you are viewing this information in softcopy, the photographs and color illustrations may not appear.

The drawings and specifications contained herein shall not be reproduced in whole or in part without the written permission of IBM.

IBM has prepared this information for use with the specific machines indicated. IBM makes no representations that it is suitable for any other purpose.

IBM's computer systems contain mechanisms designed to reduce the possibility of undetected data corruption or loss. This risk, however, cannot be eliminated. Users who experience unplanned outages, system failures, power fluctuations or outages, or component failures must verify the accuracy of operations performed and data saved or transmitted by the system at or near the time of the outage or failure. In addition, users must establish procedures to ensure that there is independent data verification before relying on such data in sensitive or critical operations. Users should periodically check IBM's support websites for updated information and fixes applicable to the system and related software.

## Homologation statement

This product may not be certified in your country for connection by any means whatsoever to interfaces of public telecommunications networks. Further certification may be required by law prior to making any such connection. Contact an IBM representative or reseller for any questions.

---

## Accessibility features for IBM Power Systems servers

Accessibility features assist users who have a disability, such as restricted mobility or limited vision, to use information technology content successfully.

### Overview

The IBM Power Systems servers include the following major accessibility features:

- Keyboard-only operation
- Operations that use a screen reader

The IBM Power Systems servers use the latest W3C Standard, WAI-ARIA 1.0 ([www.w3.org/TR/wai-aria/](http://www.w3.org/TR/wai-aria/)), to ensure compliance with US Section 508 ([www.access-board.gov/guidelines-and-standards/communications-and-it/about-the-section-508-standards/section-508-standards](http://www.access-board.gov/guidelines-and-standards/communications-and-it/about-the-section-508-standards/section-508-standards)) and Web Content Accessibility Guidelines (WCAG) 2.0 ([www.w3.org/TR/WCAG20/](http://www.w3.org/TR/WCAG20/)). To take advantage of accessibility features, use the latest release of your screen reader and the latest web browser that is supported by the IBM Power Systems servers.

The IBM Power Systems servers online product documentation in IBM Knowledge Center is enabled for accessibility. The accessibility features of IBM Knowledge Center are described in the Accessibility section of the IBM Knowledge Center help ([www.ibm.com/support/knowledgcenter/doc/kc\\_help.html#accessibility](http://www.ibm.com/support/knowledgcenter/doc/kc_help.html#accessibility)).

## Keyboard navigation

This product uses standard navigation keys.

## Interface information

The IBM Power Systems servers user interfaces do not have content that flashes 2 - 55 times per second.

The IBM Power Systems servers web user interface relies on cascading style sheets to render content properly and to provide a usable experience. The application provides an equivalent way for low-vision users to use system display settings, including high-contrast mode. You can control font size by using the device or web browser settings.

The IBM Power Systems servers web user interface includes WAI-ARIA navigational landmarks that you can use to quickly navigate to functional areas in the application.

## Vendor software

The IBM Power Systems servers include certain vendor software that is not covered under the IBM license agreement. IBM makes no representation about the accessibility features of these products. Contact the vendor for accessibility information about its products.

## Related accessibility information

In addition to standard IBM help desk and support websites, IBM has a TTY telephone service for use by deaf or hard of hearing customers to access sales and support services:

TTY service  
800-IBM-3383 (800-426-3383)  
(within North America)

For more information about the commitment that IBM has to accessibility, see IBM Accessibility ([www.ibm.com/able](http://www.ibm.com/able)).

---

## Privacy policy considerations

IBM Software products, including software as a service solutions, (“Software Offerings”) may use cookies or other technologies to collect product usage information, to help improve the end user experience, to tailor interactions with the end user, or for other purposes. In many cases no personally identifiable information is collected by the Software Offerings. Some of our Software Offerings can help enable you to collect personally identifiable information. If this Software Offering uses cookies to collect personally identifiable information, specific information about this offering’s use of cookies is set forth below.

This Software Offering does not use cookies or other technologies to collect personally identifiable information.

If the configurations deployed for this Software Offering provide you as the customer the ability to collect personally identifiable information from end users via cookies and other technologies, you should seek your own legal advice about any laws applicable to such data collection, including any requirements for notice and consent.

For more information about the use of various technologies, including cookies, for these purposes, see IBM’s Privacy Policy at <http://www.ibm.com/privacy> and IBM’s Online Privacy Statement at <http://www.ibm.com/privacy/details> the section entitled “Cookies, Web Beacons and Other Technologies” and the “IBM Software Products and Software-as-a-Service Privacy Statement” at <http://www.ibm.com/software/info/product-privacy>.

---

## Trademarks

IBM, the IBM logo, and ibm.com are trademarks or registered trademarks of International Business Machines Corp., registered in many jurisdictions worldwide. Other product and service names might be trademarks of IBM or other companies. A current list of IBM trademarks is available on the web at Copyright and trademark information at [www.ibm.com/legal/copytrade.shtml](http://www.ibm.com/legal/copytrade.shtml).

---

## Electronic emission notices

When attaching a monitor to the equipment, you must use the designated monitor cable and any interference suppression devices supplied with the monitor.

## Class A Notices

The following Class A statements apply to the IBM servers that contain the POWER8 processor and its features unless designated as electromagnetic compatibility (EMC) Class B in the feature information.

## Federal Communications Commission (FCC) Statement

**Note:** This equipment has been tested and found to comply with the limits for a Class A digital device, pursuant to Part 15 of the FCC Rules. These limits are designed to provide reasonable protection against harmful interference when the equipment is operated in a commercial environment. This equipment generates, uses, and can radiate radio frequency energy and, if not installed and used in accordance with the instruction manual, may cause harmful interference to radio communications. Operation of this equipment in a residential area is likely to cause harmful interference, in which case the user will be required to correct the interference at his own expense.

Properly shielded and grounded cables and connectors must be used in order to meet FCC emission limits. IBM is not responsible for any radio or television interference caused by using other than recommended cables and connectors or by unauthorized changes or modifications to this equipment. Unauthorized changes or modifications could void the user's authority to operate the equipment.

This device complies with Part 15 of the FCC rules. Operation is subject to the following two conditions: (1) this device may not cause harmful interference, and (2) this device must accept any interference received, including interference that may cause undesired operation.

## Industry Canada Compliance Statement

CAN ICES-3 (A)/NMB-3(A)

## European Community Compliance Statement

This product is in conformity with the protection requirements of EU Council Directive 2014/30/EU on the approximation of the laws of the Member States relating to electromagnetic compatibility. IBM cannot accept responsibility for any failure to satisfy the protection requirements resulting from a non-recommended modification of the product, including the fitting of non-IBM option cards.

European Community contact:

IBM Deutschland GmbH

Technical Regulations, Abteilung M456

IBM-Allee 1, 71139 Ehningen, Germany

Tel: +49 800 225 5426

email: [halloibm@de.ibm.com](mailto:halloibm@de.ibm.com)

**Warning:** This is a Class A product. In a domestic environment, this product may cause radio interference, in which case the user may be required to take adequate measures.

## VCCI Statement - Japan

この装置は、クラスA 情報技術装置です。この装置を家庭環境で使用すると電波妨害を引き起こすことがあります。この場合には使用者が適切な対策を講ずるよう要求されることがあります。 VCCI-A

The following is a summary of the VCCI Japanese statement in the box above:

This is a Class A product based on the standard of the VCCI Council. If this equipment is used in a domestic environment, radio interference may occur, in which case, the user may be required to take corrective actions.

## Japan Electronics and Information Technology Industries Association Statement

This statement explains the Japan JIS C 61000-3-2 product wattage compliance.

(一社) 電子情報技術産業協会 高調波電流抑制対策実施  
要領に基づく定格入力電力値： Knowledge Centerの各製品の  
仕様ページ参照

This statement explains the Japan Electronics and Information Technology Industries Association (JEITA) statement for products less than or equal to 20 A per phase.

高調波電流規格 JIS C 61000-3-2 適合品

This statement explains the JEITA statement for products greater than 20 A, single phase.

高調波電流規格 JIS C 61000-3-2 準用品

本装置は、「高圧又は特別高圧で受電する需要家の高調波抑制対策ガイドライン」対象機器（高調波発生機器）です。

- 回路分類：6（単相、PFC回路付）
- 換算係数：0

This statement explains the JEITA statement for products greater than 20 A per phase, three-phase.

高調波電流規格 JIS C 61000-3-2 準用品

本装置は、「高圧又は特別高圧で受電する需要家の高調波抑制対策ガイドライン」対象機器（高調波発生機器）です。

- 回路分類 : 5 (3相、PFC回路付)
- 換算係数 : 0

**Electromagnetic Interference (EMI) Statement - People's Republic of China**

声 明

此为 A 级产品, 在生活环境中, 该产品可能会造成无线电干扰。在这种情况下, 可能需要用户对其干扰采取切实可行的措施。

Declaration: This is a Class A product. In a domestic environment this product may cause radio interference in which case the user may need to perform practical action.

**Electromagnetic Interference (EMI) Statement - Taiwan**

警告使用者：

這是甲類的資訊產品，在居住的環境中使用時，可能會造成射頻干擾，在這種情況下，使用者會被要求採取某些適當的對策。

The following is a summary of the EMI Taiwan statement above.

Warning: This is a Class A product. In a domestic environment this product may cause radio interference in which case the user will be required to take adequate measures.

**IBM Taiwan Contact Information:**

台灣IBM 產品服務聯絡方式：  
台灣國際商業機器股份有限公司  
台北市松仁路7號3樓  
電話：0800-016-888

## **Electromagnetic Interference (EMI) Statement - Korea**

이 기기는 업무용 환경에서 사용할 목적으로 적합성평가를 받은 기기로서 가정용 환경에서 사용하는 경우 전파간섭의 우려가 있습니다.

## **Germany Compliance Statement**

### **Deutschsprachiger EU Hinweis: Hinweis für Geräte der Klasse A EU-Richtlinie zur Elektromagnetischen Verträglichkeit**

Dieses Produkt entspricht den Schutzanforderungen der EU-Richtlinie 2014/30/EU zur Angleichung der Rechtsvorschriften über die elektromagnetische Verträglichkeit in den EU-Mitgliedsstaaten und hält die Grenzwerte der EN 55022 / EN 55032 Klasse A ein.

Um dieses sicherzustellen, sind die Geräte wie in den Handbüchern beschrieben zu installieren und zu betreiben. Des Weiteren dürfen auch nur von der IBM empfohlene Kabel angeschlossen werden. IBM übernimmt keine Verantwortung für die Einhaltung der Schutzanforderungen, wenn das Produkt ohne Zustimmung von IBM verändert bzw. wenn Erweiterungskomponenten von Fremdherstellern ohne Empfehlung von IBM gesteckt/eingebaut werden.

EN 55022 / EN 55032 Klasse A Geräte müssen mit folgendem Warnhinweis versehen werden:  
"Warnung: Dieses ist eine Einrichtung der Klasse A. Diese Einrichtung kann im Wohnbereich Funk-Störungen verursachen; in diesem Fall kann vom Betreiber verlangt werden, angemessene Maßnahmen zu ergreifen und dafür aufzukommen."

### **Deutschland: Einhaltung des Gesetzes über die elektromagnetische Verträglichkeit von Geräten**

Dieses Produkt entspricht dem "Gesetz über die elektromagnetische Verträglichkeit von Geräten (EMVG)". Dies ist die Umsetzung der EU-Richtlinie 2014/30/EU in der Bundesrepublik Deutschland.

### **Zulassungsbescheinigung laut dem Deutschen Gesetz über die elektromagnetische Verträglichkeit von Geräten (EMVG) (bzw. der EMC Richtlinie 2014/30/EU) für Geräte der Klasse A**

Dieses Gerät ist berechtigt, in Übereinstimmung mit dem Deutschen EMVG das EG-Konformitätszeichen - CE - zu führen.

Verantwortlich für die Einhaltung der EMV Vorschriften ist der Hersteller:  
International Business Machines Corp.  
New Orchard Road  
Armonk, New York 10504  
Tel: 914-499-1900

Der verantwortliche Ansprechpartner des Herstellers in der EU ist:  
IBM Deutschland GmbH  
Technical Relations Europe, Abteilung M456  
IBM-Allee 1, 71139 Ehningen, Germany  
Tel: +49 (0) 800 225 5426  
email: HalloIBM@de.ibm.com

Generelle Informationen:

**Das Gerät erfüllt die Schutzanforderungen nach EN 55024 und EN 55022 / EN 55032 Klasse A.**

## **Electromagnetic Interference (EMI) Statement - Russia**

**ВНИМАНИЕ!** Настоящее изделие относится к классу А.  
В жилых помещениях оно может создавать  
радиопомехи, для снижения которых необходимы  
дополнительные меры

### **Class B Notices**

The following Class B statements apply to features designated as electromagnetic compatibility (EMC) Class B in the feature installation information.

### **Federal Communications Commission (FCC) Statement**

This equipment has been tested and found to comply with the limits for a Class B digital device, pursuant to Part 15 of the FCC Rules. These limits are designed to provide reasonable protection against harmful interference in a residential installation.

This equipment generates, uses, and can radiate radio frequency energy and, if not installed and used in accordance with the instructions, may cause harmful interference to radio communications. However, there is no guarantee that interference will not occur in a particular installation.

If this equipment does cause harmful interference to radio or television reception, which can be determined by turning the equipment off and on, the user is encouraged to try to correct the interference by one or more of the following measures:

- Reorient or relocate the receiving antenna.
- Increase the separation between the equipment and receiver.
- Connect the equipment into an outlet on a circuit different from that to which the receiver is connected.
- Consult an IBM-authorized dealer or service representative for help.

Properly shielded and grounded cables and connectors must be used in order to meet FCC emission limits. Proper cables and connectors are available from IBM-authorized dealers. IBM is not responsible for any radio or television interference caused by unauthorized changes or modifications to this equipment. Unauthorized changes or modifications could void the user's authority to operate this equipment.

This device complies with Part 15 of the FCC rules. Operation is subject to the following two conditions: (1) this device may not cause harmful interference, and (2) this device must accept any interference received, including interference that may cause undesired operation.

### **Industry Canada Compliance Statement**

CAN ICES-3 (B)/NMB-3(B)

### **European Community Compliance Statement**

This product is in conformity with the protection requirements of EU Council Directive 2014/30/EU on the approximation of the laws of the Member States relating to electromagnetic compatibility. IBM cannot accept responsibility for any failure to satisfy the protection requirements resulting from a non-recommended modification of the product, including the fitting of non-IBM option cards.



European Community contact:  
IBM Deutschland GmbH  
Technical Regulations, Abteilung M456  
IBM-Allee 1, 71139 Ehningen, Germany  
Tel: +49 800 225 5426  
email: halloibm@de.ibm.com

## VCCI Statement - Japan

この装置は、クラスB情報技術装置です。この装置は、家庭環境で使用することを目的としていますが、この装置がラジオやテレビジョン受信機に近接して使用されると、受信障害を引き起こすことがあります。

取扱説明書に従って正しい取り扱いをして下さい。 VCCI-B

## Japan Electronics and Information Technology Industries Association Statement

This statement explains the Japan JIS C 61000-3-2 product wattage compliance.

(一社) 電子情報技術産業協会 高調波電流抑制対策実施  
要領に基づく定格入力電力値 : Knowledge Centerの各製品の  
仕様ページ参照

This statement explains the Japan Electronics and Information Technology Industries Association (JEITA) statement for products less than or equal to 20 A per phase.

高調波電流規格 JIS C 61000-3-2 適合品

This statement explains the JEITA statement for products greater than 20 A, single phase.

高調波電流規格 JIS C 61000-3-2 準用品

本装置は、「高圧又は特別高圧で受電する需要家の高調波抑制対策ガイドライン」対象機器（高調波発生機器）です。

- 回路分類 : 6 (単相、PFC回路付)
- 換算係数 : 0

This statement explains the JEITA statement for products greater than 20 A per phase, three-phase.

高調波電流規格 JIS C 61000-3-2 準用品

本装置は、「高圧又は特別高圧で受電する需要家の高調波抑制対策ガイドライン」対象機器（高調波発生機器）です。

- 回路分類 : 5 (3相、PFC回路付)
- 換算係数 : 0

### IBM Taiwan Contact Information

台灣IBM 產品服務聯絡方式：  
台灣國際商業機器股份有限公司  
台北市松仁路7號3樓  
電話：0800-016-888

### Germany Compliance Statement

**Deutschsprachiger EU Hinweis: Hinweis für Geräte der Klasse B EU-Richtlinie zur Elektromagnetischen Verträglichkeit**

Dieses Produkt entspricht den Schutzanforderungen der EU-Richtlinie 2014/30/EU zur Angleichung der Rechtsvorschriften über die elektromagnetische Verträglichkeit in den EU-Mitgliedsstaaten und hält die Grenzwerte der EN 55022/ EN 55032 Klasse B ein.

Um dieses sicherzustellen, sind die Geräte wie in den Handbüchern beschrieben zu installieren und zu betreiben. Des Weiteren dürfen auch nur von der IBM empfohlene Kabel angeschlossen werden. IBM übernimmt keine Verantwortung für die Einhaltung der Schutzanforderungen, wenn das Produkt ohne Zustimmung von IBM verändert bzw. wenn Erweiterungskomponenten von Fremdherstellern ohne Empfehlung von IBM gesteckt/eingebaut werden.

**Deutschland: Einhaltung des Gesetzes über die elektromagnetische Verträglichkeit von Geräten**

Dieses Produkt entspricht dem "Gesetz über die elektromagnetische Verträglichkeit von Geräten (EMVG)". Dies ist die Umsetzung der EU-Richtlinie 2014/30/EU in der Bundesrepublik Deutschland.

**Zulassungsbescheinigung laut dem Deutschen Gesetz über die elektromagnetische Verträglichkeit von Geräten (EMVG) (bzw. der EMC Richtlinie 2014/30/EU) für Geräte der Klasse B**

Dieses Gerät ist berechtigt, in Übereinstimmung mit dem Deutschen EMVG das EG-Konformitätszeichen - CE - zu führen.

Verantwortlich für die Einhaltung der EMV Vorschriften ist der Hersteller:  
International Business Machines Corp.  
New Orchard Road  
Armonk, New York 10504

Tel: 914-499-1900

Der verantwortliche Ansprechpartner des Herstellers in der EU ist:

IBM Deutschland GmbH  
Technical Relations Europe, Abteilung M456  
IBM-Allee 1, 71139 Ehningen, Germany  
Tel: +49 (0) 800 225 5426  
email: HalloIBM@de.ibm.com

Generelle Informationen:

**Das Gerät erfüllt die Schutzanforderungen nach EN 55024 und EN 55022/ EN 55032 Klasse B.**

---

## Terms and conditions

Permissions for the use of these publications are granted subject to the following terms and conditions.

**Applicability:** These terms and conditions are in addition to any terms of use for the IBM website.

**Personal Use:** You may reproduce these publications for your personal, noncommercial use provided that all proprietary notices are preserved. You may not distribute, display or make derivative works of these publications, or any portion thereof, without the express consent of IBM.

**Commercial Use:** You may reproduce, distribute and display these publications solely within your enterprise provided that all proprietary notices are preserved. You may not make derivative works of these publications, or reproduce, distribute or display these publications or any portion thereof outside your enterprise, without the express consent of IBM.

**Rights:** Except as expressly granted in this permission, no other permissions, licenses or rights are granted, either express or implied, to the publications or any information, data, software or other intellectual property contained therein.

IBM reserves the right to withdraw the permissions granted herein whenever, in its discretion, the use of the publications is detrimental to its interest or, as determined by IBM, the above instructions are not being properly followed.

You may not download, export or re-export this information except in full compliance with all applicable laws and regulations, including all United States export laws and regulations.

IBM MAKES NO GUARANTEE ABOUT THE CONTENT OF THESE PUBLICATIONS. THE PUBLICATIONS ARE PROVIDED "AS-IS" AND WITHOUT WARRANTY OF ANY KIND, EITHER EXPRESSED OR IMPLIED, INCLUDING BUT NOT LIMITED TO IMPLIED WARRANTIES OF MERCHANTABILITY, NON-INFRINGEMENT, AND FITNESS FOR A PARTICULAR PURPOSE.







Printed in USA