

Power Systems

*Installing the Model 024, ESLL, or  
ESLS storage enclosure*





Power Systems

*Installing the Model 024, ESLL, or  
ESLS storage enclosure*



**Note**

Before using this information and the product it supports, read the information in “Safety notices” on page v, “Notices” on page 35, the *IBM Systems Safety Notices* manual, G229-9054, and the *IBM Environmental Notices and User Guide*, Z125-5823.

This edition applies to IBM Power Systems™ servers that contain the POWER8® processor and to all associated models.

© Copyright IBM Corporation 2016, 2017.

US Government Users Restricted Rights – Use, duplication or disclosure restricted by GSA ADP Schedule Contract with IBM Corp.

---

# Contents

<b>Safety notices</b>	<b>v</b>
<b>Installing the Model 024, ESLL, or ESLS storage enclosure</b>	<b>1</b>
Preparing to install the 5147-024, ESLL, or ESLS storage enclosure	1
Completing inventory for the 5147-024, ESLL, or ESLS storage enclosure	2
Determining and marking the location in the rack	2
Installing support rails into the rack	4
Installing the 5147-024, ESLL, or ESLS storage enclosure into a rack	7
Optional: Install disk drives or SSDs in the 5147-024, ESLL, or ESLS storage enclosure.	9
Connecting the 5147-024, ESLL, or ESLS storage enclosure to your system	11
Connecting cables, power cords, and installing covers	22
Completing the 5147-024, ESLL, or ESLS storage enclosure installation	24
<b>Reference information</b>	<b>25</b>
Stopping a system or logical partition	25
Stopping a system that is not managed by an HMC	25
Stopping a system by using the control panel	25
Stopping a system by using the ASMI	25
Stopping a system by using the HMC	26
Stopping a system by using the HMC Classic or HMC Enhanced interface	26
Stopping a system by using the HMC Enhanced + Tech Preview (Pre-GA) or HMC Enhanced+ interface	26
Stopping an IBM PowerKVM system	27
Starting the system or logical partition	27
Starting a system that is not managed by an HMC	27
Starting a system by using the control panel	27
Starting a system by using the ASMI	29
Starting a system or logical partition by using the HMC	29
Starting a system or logical partition by using the HMC Classic or HMC Enhanced interface	29
Starting a system or logical partition by using the HMC Enhanced + Tech Preview (Pre-GA) or HMC Enhanced+ interface	29
Starting an IBM PowerKVM system	30
Connector locations	30
Connector locations for the 5147-024, ESLL, and ESLS storage enclosures	31
Connector locations for the 5148-22L, 8247-21L, 8247-22L, 8284-21A, and 8284-22A systems	31
Connector locations for the 8286-41A system	31
Connector locations for the 8247-42L and 8286-42A systems	32
Connector locations for the 8408-44E and 8408-E8E systems	33
Connector locations for the 9080-MHE, 9080-MME, 9119-MHE, and 9119-MME systems	34
<b>Notices</b>	<b>35</b>
Accessibility features for IBM Power Systems servers	36
Privacy policy considerations	37
Trademarks	38
Electronic emission notices	38
Class A Notices	38
Class B Notices	42
Terms and conditions	45



---

## Safety notices

Safety notices may be printed throughout this guide:

- **DANGER** notices call attention to a situation that is potentially lethal or extremely hazardous to people.
- **CAUTION** notices call attention to a situation that is potentially hazardous to people because of some existing condition.
- **Attention** notices call attention to the possibility of damage to a program, device, system, or data.

### World Trade safety information

Several countries require the safety information contained in product publications to be presented in their national languages. If this requirement applies to your country, safety information documentation is included in the publications package (such as in printed documentation, on DVD, or as part of the product) shipped with the product. The documentation contains the safety information in your national language with references to the U.S. English source. Before using a U.S. English publication to install, operate, or service this product, you must first become familiar with the related safety information documentation. You should also refer to the safety information documentation any time you do not clearly understand any safety information in the U.S. English publications.

Replacement or additional copies of safety information documentation can be obtained by calling the IBM Hotline at 1-800-300-8751.

### German safety information

Das Produkt ist nicht für den Einsatz an Bildschirmarbeitsplätzen im Sinne § 2 der Bildschirmarbeitsverordnung geeignet.

### Laser safety information

IBM® servers can use I/O cards or features that are fiber-optic based and that utilize lasers or LEDs.

#### Laser compliance

IBM servers may be installed inside or outside of an IT equipment rack.

**DANGER:** When working on or around the system, observe the following precautions:

Electrical voltage and current from power, telephone, and communication cables are hazardous. To avoid a shock hazard:

- If IBM supplied the power cord(s), connect power to this unit only with the IBM provided power cord. Do not use the IBM provided power cord for any other product.
- Do not open or service any power supply assembly.
- Do not connect or disconnect any cables or perform installation, maintenance, or reconfiguration of this product during an electrical storm.
- The product might be equipped with multiple power cords. To remove all hazardous voltages, disconnect all power cords.
  - For AC power, disconnect all power cords from their AC power source.
  - For racks with a DC power distribution panel (PDP), disconnect the customer's DC power source to the PDP.
- When connecting power to the product ensure all power cables are properly connected.

- For racks with AC power, connect all power cords to a properly wired and grounded electrical outlet. Ensure that the outlet supplies proper voltage and phase rotation according to the system rating plate.
- For racks with a DC power distribution panel (PDP), connect the customer's DC power source to the PDP. Ensure that the proper polarity is used when attaching the DC power and DC power return wiring.
- Connect any equipment that will be attached to this product to properly wired outlets.
- When possible, use one hand only to connect or disconnect signal cables.
- Never turn on any equipment when there is evidence of fire, water, or structural damage.
- Do not attempt to switch on power to the machine until all possible unsafe conditions are corrected.
- Assume that an electrical safety hazard is present. Perform all continuity, grounding, and power checks specified during the subsystem installation procedures to ensure that the machine meets safety requirements.
- Do not continue with the inspection if any unsafe conditions are present.
- Before you open the device covers, unless instructed otherwise in the installation and configuration procedures: Disconnect the attached AC power cords, turn off the applicable circuit breakers located in the rack power distribution panel (PDP), and disconnect any telecommunications systems, networks, and modems.

**DANGER:**

- Connect and disconnect cables as described in the following procedures when installing, moving, or opening covers on this product or attached devices.

To Disconnect:

1. Turn off everything (unless instructed otherwise).
2. For AC power, remove the power cords from the outlets.
3. For racks with a DC power distribution panel (PDP), turn off the circuit breakers located in the PDP and remove the power from the Customer's DC power source.
4. Remove the signal cables from the connectors.
5. Remove all cables from the devices.

To Connect:

1. Turn off everything (unless instructed otherwise).
2. Attach all cables to the devices.
3. Attach the signal cables to the connectors.
4. For AC power, attach the power cords to the outlets.
5. For racks with a DC power distribution panel (PDP), restore the power from the Customer's DC power source and turn on the circuit breakers located in the PDP.
6. Turn on the devices.

Sharp edges, corners and joints may be present in and around the system. Use care when handling equipment to avoid cuts, scrapes and pinching. (D005)

**(R001 part 1 of 2):**

**DANGER:** Observe the following precautions when working on or around your IT rack system:

- Heavy equipment—personal injury or equipment damage might result if mishandled.
- Always lower the leveling pads on the rack cabinet.
- Always install stabilizer brackets on the rack cabinet.
- To avoid hazardous conditions due to uneven mechanical loading, always install the heaviest devices in the bottom of the rack cabinet. Always install servers and optional devices starting from the bottom of the rack cabinet.
- Rack-mounted devices are not to be used as shelves or work spaces. Do not place objects on top of rack-mounted devices. In addition, do not lean on rack mounted devices and do not use them to stabilize your body position (for example, when working from a ladder).





- Each rack cabinet might have more than one power cord.
  - For AC powered racks, be sure to disconnect all power cords in the rack cabinet when directed to disconnect power during servicing.
  - For racks with a DC power distribution panel (PDP), turn off the circuit breaker that controls the power to the system unit(s), or disconnect the customer's DC power source, when directed to disconnect power during servicing.
- Connect all devices installed in a rack cabinet to power devices installed in the same rack cabinet. Do not plug a power cord from a device installed in one rack cabinet into a power device installed in a different rack cabinet.
- An electrical outlet that is not correctly wired could place hazardous voltage on the metal parts of the system or the devices that attach to the system. It is the responsibility of the customer to ensure that the outlet is correctly wired and grounded to prevent an electrical shock.

**(R001 part 2 of 2):**

**CAUTION:**

- Do not install a unit in a rack where the internal rack ambient temperatures will exceed the manufacturer's recommended ambient temperature for all your rack-mounted devices.
- Do not install a unit in a rack where the air flow is compromised. Ensure that air flow is not blocked or reduced on any side, front, or back of a unit used for air flow through the unit.
- Consideration should be given to the connection of the equipment to the supply circuit so that overloading of the circuits does not compromise the supply wiring or overcurrent protection. To provide the correct power connection to a rack, refer to the rating labels located on the equipment in the rack to determine the total power requirement of the supply circuit.
- *(For sliding drawers.)* Do not pull out or install any drawer or feature if the rack stabilizer brackets are not attached to the rack. Do not pull out more than one drawer at a time. The rack might become unstable if you pull out more than one drawer at a time.



- *(For fixed drawers.)* This drawer is a fixed drawer and must not be moved for servicing unless specified by the manufacturer. Attempting to move the drawer partially or completely out of the rack might cause the rack to become unstable or cause the drawer to fall out of the rack.

**CAUTION:**

Removing components from the upper positions in the rack cabinet improves rack stability during relocation. Follow these general guidelines whenever you relocate a populated rack cabinet within a room or building.

- Reduce the weight of the rack cabinet by removing equipment starting at the top of the rack cabinet. When possible, restore the rack cabinet to the configuration of the rack cabinet as you received it. If this configuration is not known, you must observe the following precautions:
  - Remove all devices in the 32U position (compliance ID RACK-001 or 22U (compliance ID RR001) and above.
  - Ensure that the heaviest devices are installed in the bottom of the rack cabinet.
  - Ensure that there are little-to-no empty U-levels between devices installed in the rack cabinet below the 32U (compliance ID RACK-001 or 22U (compliance ID RR001) level, unless the received configuration specifically allowed it.
- If the rack cabinet you are relocating is part of a suite of rack cabinets, detach the rack cabinet from the suite.
- If the rack cabinet you are relocating was supplied with removable outriggers they must be reinstalled before the cabinet is relocated.
- Inspect the route that you plan to take to eliminate potential hazards.
- Verify that the route that you choose can support the weight of the loaded rack cabinet. Refer to the documentation that comes with your rack cabinet for the weight of a loaded rack cabinet.
- Verify that all door openings are at least 760 x 230 mm (30 x 80 in.).
- Ensure that all devices, shelves, drawers, doors, and cables are secure.
- Ensure that the four leveling pads are raised to their highest position.
- Ensure that there is no stabilizer bracket installed on the rack cabinet during movement.
- Do not use a ramp inclined at more than 10 degrees.
- When the rack cabinet is in the new location, complete the following steps:
  - Lower the four leveling pads.
  - Install stabilizer brackets on the rack cabinet.
  - If you removed any devices from the rack cabinet, repopulate the rack cabinet from the lowest position to the highest position.
- If a long-distance relocation is required, restore the rack cabinet to the configuration of the rack cabinet as you received it. Pack the rack cabinet in the original packaging material, or equivalent. Also lower the leveling pads to raise the casters off of the pallet and bolt the rack cabinet to the pallet.

(R002)

(L001)



**DANGER:** Hazardous voltage, current, or energy levels are present inside any component that has this label attached. Do not open any cover or barrier that contains this label. (L001)

(L002)



**DANGER:** Rack-mounted devices are not to be used as shelves or work spaces. (L002)

(L003)



or



or



or



or



**DANGER:** Multiple power cords. The product might be equipped with multiple AC power cords or multiple DC power cables. To remove all hazardous voltages, disconnect all power cords and power cables. (L003)

(L007)



**CAUTION:** A hot surface nearby. (L007)

(L008)



**CAUTION:** Hazardous moving parts nearby. (L008)

All lasers are certified in the U.S. to conform to the requirements of DHHS 21 CFR Subchapter J for class 1 laser products. Outside the U.S., they are certified to be in compliance with IEC 60825 as a class 1 laser product. Consult the label on each part for laser certification numbers and approval information.

**CAUTION:**

**This product might contain one or more of the following devices: CD-ROM drive, DVD-ROM drive, DVD-RAM drive, or laser module, which are Class 1 laser products. Note the following information:**

- **Do not remove the covers. Removing the covers of the laser product could result in exposure to hazardous laser radiation. There are no serviceable parts inside the device.**
- **Use of the controls or adjustments or performance of procedures other than those specified herein might result in hazardous radiation exposure.**

(C026)

**CAUTION:**

Data processing environments can contain equipment transmitting on system links with laser modules that operate at greater than Class 1 power levels. For this reason, never look into the end of an optical fiber cable or open receptacle. Although shining light into one end and looking into the other end of a disconnected optical fiber to verify the continuity of optic fibers many not injure the eye, this procedure is potentially dangerous. Therefore, verifying the continuity of optical fibers by shining light into one end and looking at the other end is not recommended. To verify continuity of a fiber optic cable, use an optical light source and power meter. (C027)

**CAUTION:**

**This product contains a Class 1M laser. Do not view directly with optical instruments. (C028)**

**CAUTION:**

**Some laser products contain an embedded Class 3A or Class 3B laser diode. Note the following information: laser radiation when open. Do not stare into the beam, do not view directly with optical instruments, and avoid direct exposure to the beam. (C030)**

**CAUTION:**

**The battery contains lithium. To avoid possible explosion, do not burn or charge the battery.**

*Do Not:*

- **Throw or immerse into water**
- **Heat to more than 100°C (212°F)**
- **Repair or disassemble**

**Exchange only with the IBM-approved part. Recycle or discard the battery as instructed by local regulations. In the United States, IBM has a process for the collection of this battery. For information, call 1-800-426-4333. Have the IBM part number for the battery unit available when you call. (C003)**

## CAUTION:

Regarding IBM provided VENDOR LIFT TOOL:

- Operation of LIFT TOOL by authorized personnel only.
- LIFT TOOL intended for use to assist, lift, install, remove units (load) up into rack elevations. It is not to be used loaded transporting over major ramps nor as a replacement for such designated tools like pallet jacks, walkies, fork trucks and such related relocation practices. When this is not practicable, specially trained persons or services must be used (for instance, riggers or movers).
- Read and completely understand the contents of LIFT TOOL operator's manual before using. Failure to read, understand, obey safety rules, and follow instructions may result in property damage and/or personal injury. If there are questions, contact the vendor's service and support. Local paper manual must remain with machine in provided storage sleeve area. Latest revision manual available on vendor's web site.
- Test verify stabilizer brake function before each use. Do not over-force moving or rolling the LIFT TOOL with stabilizer brake engaged.
- Do not move LIFT TOOL while platform is raised, except for minor positioning.
- Do not exceed rated load capacity. See LOAD CAPACITY CHART regarding maximum loads at center versus edge of extended platform.
- Only raise load if properly centered on platform. Do not place more than 200 lb (91 kg) on edge of sliding platform shelf also considering the load's center of mass/gravity (CoG).
- Do not corner load the platform tilt riser accessory option. Secure platform riser tilt option to main shelf in all four (4x) locations with provided hardware only, prior to use. Load objects are designed to slide on/off smooth platforms without appreciable force, so take care not to push or lean. Keep riser tilt option flat at all times except for final minor adjustment when needed.
- Do not stand under overhanging load.
- Do not use on uneven surface, incline or decline (major ramps).
- Do not stack loads.
- Do not operate while under the influence of drugs or alcohol.
- Do not support ladder against LIFT TOOL.
- Tipping hazard. Do not push or lean against load with raised platform.
- Do not use as a personnel lifting platform or step. No riders.
- Do not stand on any part of lift. Not a step.
- Do not climb on mast.
- Do not operate a damaged or malfunctioning LIFT TOOL machine.
- Crush and pinch point hazard below platform. Only lower load in areas clear of personnel and obstructions. Keep hands and feet clear during operation.
- No Forks. Never lift or move bare LIFT TOOL MACHINE with pallet truck, jack or fork lift.
- Mast extends higher than platform. Be aware of ceiling height, cable trays, sprinklers, lights, and other overhead objects.
- Do not leave LIFT TOOL machine unattended with an elevated load.
- Watch and keep hands, fingers, and clothing clear when equipment is in motion.
- Turn Winch with hand power only. If winch handle cannot be cranked easily with one hand, it is probably over-loaded. Do not continue to turn winch past top or bottom of platform travel. Excessive unwinding will detach handle and damage cable. Always hold handle when lowering, unwinding. Always assure self that winch is holding load before releasing winch handle.
- A winch accident could cause serious injury. Not for moving humans. Make certain clicking sound is heard as the equipment is being raised. Be sure winch is locked in position before releasing handle. Read instruction page before operating this winch. Never allow winch to unwind freely. Freewheeling will cause uneven cable wrapping around winch drum, damage cable, and may cause serious injury. (C048)

## Power and cabling information for NEBS (Network Equipment-Building System) GR-1089-CORE

The following comments apply to the IBM servers that have been designated as conforming to NEBS (Network Equipment-Building System) GR-1089-CORE:

The equipment is suitable for installation in the following:

- Network telecommunications facilities
- Locations where the NEC (National Electrical Code) applies

The intrabuilding ports of this equipment are suitable for connection to intrabuilding or unexposed wiring or cabling only. The intrabuilding ports of this equipment *must not* be metalically connected to the interfaces that connect to the OSP (outside plant) or its wiring. These interfaces are designed for use as intrabuilding interfaces only (Type 2 or Type 4 ports as described in GR-1089-CORE) and require isolation from the exposed OSP cabling. The addition of primary protectors is not sufficient protection to connect these interfaces metalically to OSP wiring.

**Note:** All Ethernet cables must be shielded and grounded at both ends.

The ac-powered system does not require the use of an external surge protection device (SPD).

The dc-powered system employs an isolated DC return (DC-I) design. The DC battery return terminal *shall not* be connected to the chassis or frame ground.

The dc-powered system is intended to be installed in a common bonding network (CBN) as described in GR-1089-CORE.





---

## Installing the Model 024, ESLL, or ESLS storage enclosure

Learn how to install an IBM Elastic Storage Server Storage Expansion (024) (5147-024 storage enclosure), IBM EXP12SX SAS Storage Enclosure (ESLL storage enclosure), or IBM EXP24SX SAS Storage Enclosure (ESLS storage enclosure) into a rack and learn how to cable it to a system or to an adapter in a system or an expansion unit.

Installing a storage enclosure into a rack is a customer task. You can complete this task yourself, or contact a service provider to complete the task for you. You might be charged a fee by the service provider for this service.

Complete the following tasks to install the 5147-024, ESLL, or ESLS storage enclosure:

- Preparing to install the 5147-024, ESLL, or ESLS storage enclosure
- Completing inventory
- Determining and marking the location in the rack
- Installing support rails into the rack
- Installing the enclosure into the rack
- Optional: Installing disk drives or SSDs
- Connecting the enclosure to your server
- Connecting cables, power cords, and installing covers
- Completing the installation

---

## Preparing to install the 5147-024, ESLL, or ESLS storage enclosure

Learn about the prerequisites for installing the 5147-024, ESLL, or ESLS storage enclosure and determine whether you can install the enclosure concurrently.

To prepare to set up an enclosure, complete the following steps:

1. Determine the level of software that you need to support the enclosure. For instructions, see the IBM Prerequisite website ([http://www-912.ibm.com/e\\_dir/eServerPrereq.nsf](http://www-912.ibm.com/e_dir/eServerPrereq.nsf)).
2. Determine whether you can add your enclosure concurrently by reviewing the following information. You can add your enclosure concurrently (with the system powered on and partitions active) if you have one of the following configurations:
  - Your system is managed by an IBM Hardware Management Console (HMC).
  - Your system is not managed by an HMC, but has only one partition, and that partition is running the IBM i operating system.

**Note:** If you do not have one of these configurations, you must power off the system to add enclosures.
3. Choose one of the following options:
  - If your 5147-024, ESLL, or ESLS storage enclosure arrived to your site preinstalled in a rack, continue with step 4.
  - If your 5147-024, ESLL, or ESLS storage enclosure needs to be installed into a rack, continue with step 5 on page 2.
4. If your 5147-024, ESLL, or ESLS storage enclosure arrived to your site preinstalled in a rack, continue with one of the following procedures:
  - If you want to install disk drives or solid-state drives (SSDs), continue with “Optional: Install disk drives or SSDs in the 5147-024, ESLL, or ESLS storage enclosure” on page 9.

- If you want to connect your 5147-024, ESLL, or ESLS storage enclosure to your system, continue with “Connecting the 5147-024, ESLL, or ESLS storage enclosure to your system” on page 11.
5. If you need to install the 5147-024, ESLL, or ESLS storage enclosure into a rack, ensure that you have the following items before you start your installation:

- Phillips screwdrivers
- Flat-head screwdriver
- Rack with two Electronic Industries Alliance (EIA) units of contiguous space.

**Note:** If you do not have a rack that is installed, install the rack. For instructions, see Racks and rack features ([http://www.ibm.com/support/knowledgecenter/POWER8/p8hbf/p8hbf\\_8xx\\_kickoff.htm](http://www.ibm.com/support/knowledgecenter/POWER8/p8hbf/p8hbf_8xx_kickoff.htm)).

---

## Completing inventory for the 5147-024, ESLL, or ESLS storage enclosure

To complete inventory, complete the steps in this procedure.

1. Refer to the inventory list, and verify that you received all of the parts that you ordered. At a minimum, each order contains the following items:
  - Left and right rack-mounting hardware
  - Mounting screws
  - Power supply cables
2. If your shipment contains parts that are not required to complete the installation procedure, store those parts in case they are needed in the future.
3. If you have incorrect, missing, or damaged parts, consult any of the following resources:
  - Your IBM reseller.
  - IBM Rochester manufacturing automated information at 1-800-300-8751 (United States only).
  - See the Directory of worldwide contacts website(<http://www.ibm.com/planetwide>). Select your location to view the service and support contact information.
4. If you have incorrect, missing, or damaged parts, consult your next level of support.

---

## Determining and marking the location in the rack

Learn how to determine where to install the disk drive enclosure into the rack.

Read the Rack safety notices (<http://www.ibm.com/support/knowledgecenter/POWER8/p8hbf/racksafety.htm>).

To determine where to install the storage enclosure into a rack, complete the following steps:

1. Determine where in the rack to place the enclosure in relation to other system hardware. As you plan for installing the enclosure in a rack, keep in mind the following information:
  - Organize larger and heavier units into the lower part of the rack.
  - Plan to install units into the lower part of the rack first.
  - Record the Electronic Industries Alliance (EIA) locations in your plan.

**Note:** The 5147-024, ESLL, and ESLS storage enclosures are two EIA units high. An EIA unit is 44.50 mm (1.75 in) in height. The rack contains three mounting holes for each EIA unit of height. This enclosure, therefore, is 89 mm (3.5 in) high and covers six mounting holes in the rack.

2. If necessary, open or remove the front and rear rack doors.
3. Attach the electrostatic discharge (ESD) wrist strap.

**Attention:**

- Attach an electrostatic discharge (ESD) wrist strap to the front ESD jack, to the rear ESD jack, or to an unpainted metal surface of your hardware to prevent the electrostatic discharge from damaging your hardware.
  - When you use an ESD wrist strap, follow all electrical safety procedures. An ESD wrist strap is used for static control. It does not increase or decrease your risk of receiving electric shock when using or working on electrical equipment.
  - If you do not have an ESD wrist strap, just prior to removing the product from ESD packaging and installing or replacing hardware, touch an unpainted metal surface of the system for a minimum of 5 seconds.
4. If necessary, remove the filler panels to allow access to the inside of the rack enclosure where you plan to place the enclosure. See Figure 1.

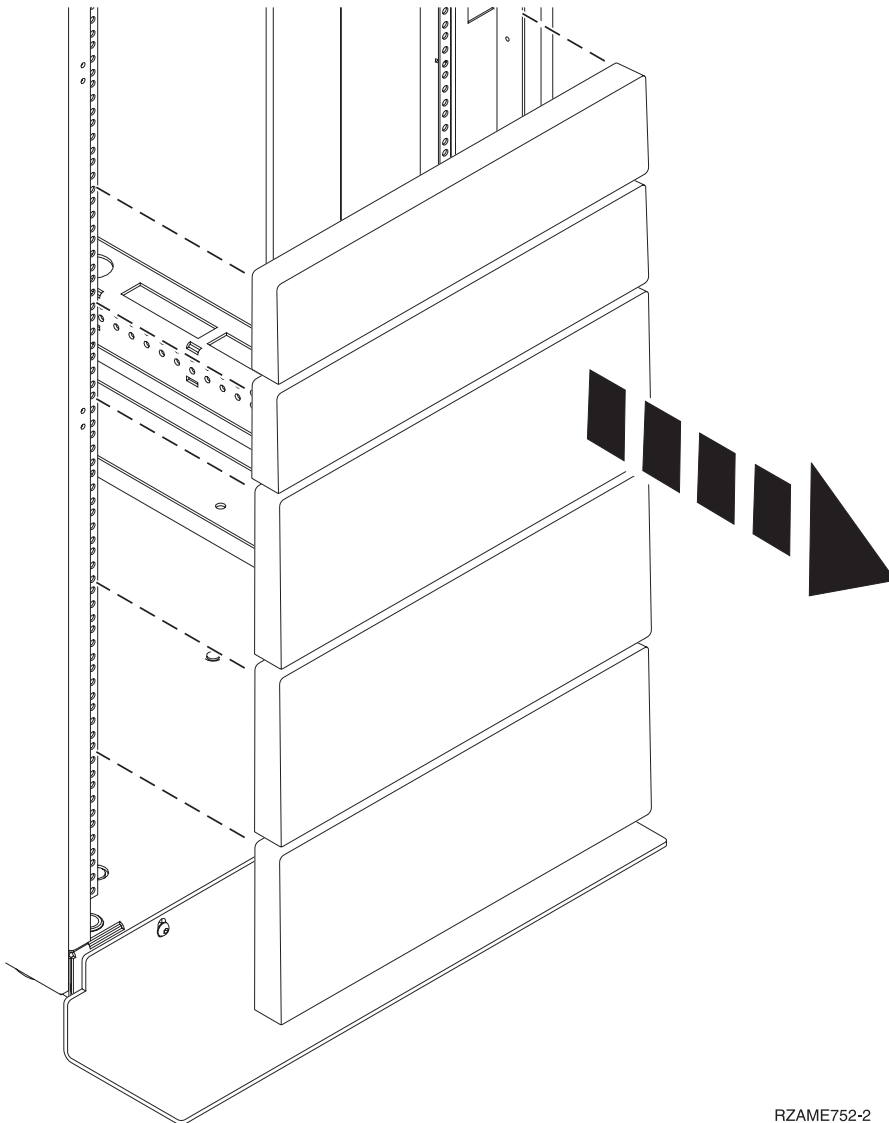

RZAME752-2

*Figure 1. Removing the filler panels*

5. Face the front of the rack and work from the left side to complete the following steps:
- a. Make a note of the lowest EIA unit to be used for the enclosure.
  - b. Use tape, a marker, or a pencil to mark the top mounting hole **(A)** of the lowest EIA unit.

**Note:** Mark the rack so that these marks can also be seen from the rear of the rack.

- c. Count up two holes and place another mark beside that mounting hole (**B**).

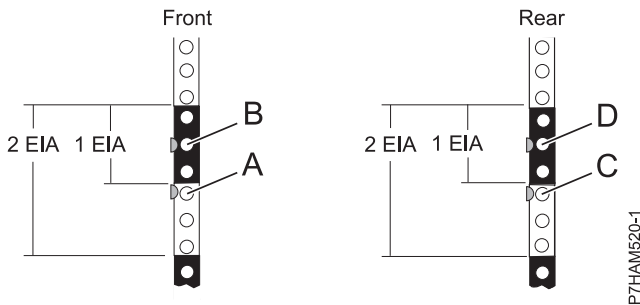

Figure 2. Marking the installation locations

6. Repeat step 5 on page 3 to place two marks on the corresponding mounting holes on the front-right side of the rack.
7. Go to the rear of the rack and work from the left side to complete the following steps:
  - a. Find the EIA unit that corresponds to the lowest EIA unit marked on the front of the rack.
  - b. Use tape, a marker, or a pencil to mark the top mounting hole (**C**) of the lowest EIA unit.
  - c. Count up two holes and place another mark beside that mounting hole (**D**).
8. Repeat step 7 to place two marks on the corresponding mounting holes on the rear-right side of the rack.

---

## Installing support rails into the rack

Before you install a storage enclosure, you must first install support rails. The information is intended to promote safety and reliable operation, and includes illustrations of the related hardware components and shows how these components relate to each other.

**Attention:** To avoid rail failure and potential danger to yourself and to the unit, ensure that you have the correct rails and fittings for your rack. If your rack has square support flange holes or screw-thread support flange holes, ensure that the rails and fittings match the support flange holes that are used on your rack. Do not install mismatched hardware by using washers or spacers. If you do not have the correct rails and fittings for your rack, contact your IBM reseller.

**Important:** The rail installation can be completed by one person. However, the installation is easier if one person is positioned at the front of the rack and one person is positioned at the rear of the rack.

To install the support rails into the rack, complete the following steps:

1. Ensure that you have the electrostatic discharge (ESD) wrist strap attached. If not, attach it now.
2. Select a rail and remove any parts that were taped to it for shipping.
3. Extend the rail to expose both circular standoffs.
4. Install the spring to the rail by hooking one end around one of the circular standoffs (**A**) and the other end around the other circular standoff (**B**) as shown in Figure 3 on page 5.

**Note:** If your rack has the square mounting holes, remove the rail pins from the rail. Install the larger rail pins that are provided with the rack installation kit.

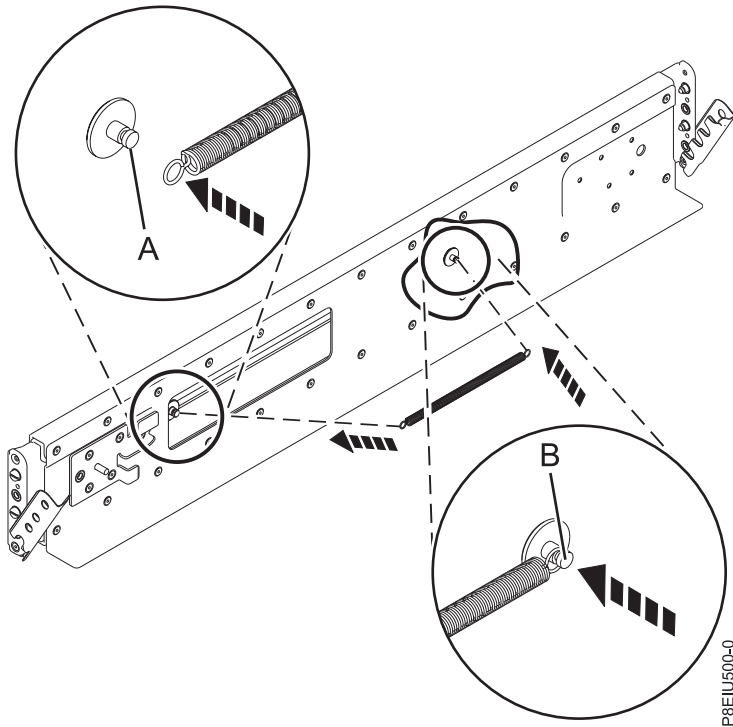

P8EIU500-0

Figure 3. Installing the spring to the rail

5. Open the hinge bracket on each end of the rail.

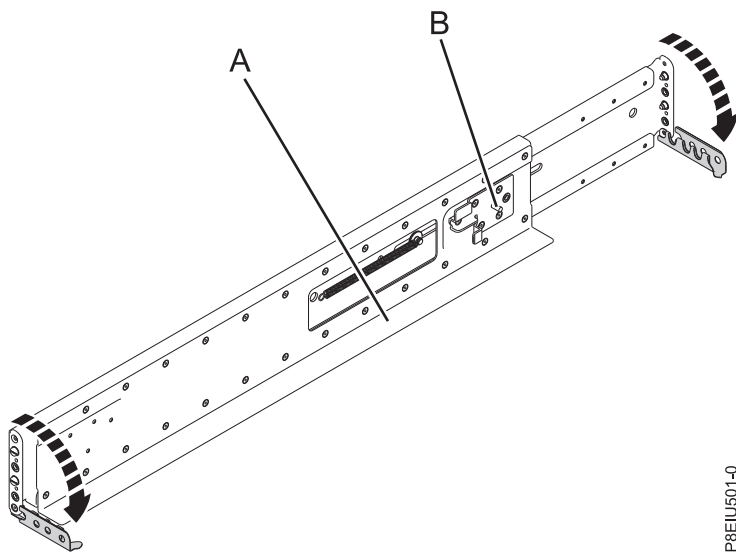

P8EIU501-0

Figure 4. Opening the rail hinge bracket

6. Identify the side of the rack where the rail must be mounted by holding the rail inside of the open space of the rack as follows:
  - The rail points from front to rear.
  - The support ledge (**A**) is at the bottom and points toward the center of the open space inside the rack.
  - The enclosure stop (**B**) is located toward the rear of the rack.

7. Locate the two marks that were made previously on the Electronic Industries Alliances (EIA) strips.
8. Align the rail bracket inside the rack cabinet beside the marks, and seat the front of the support rail bracket pins in the mounting holes. The bottom of the rail support ledge appears slightly higher than the U mark on the rack flange.

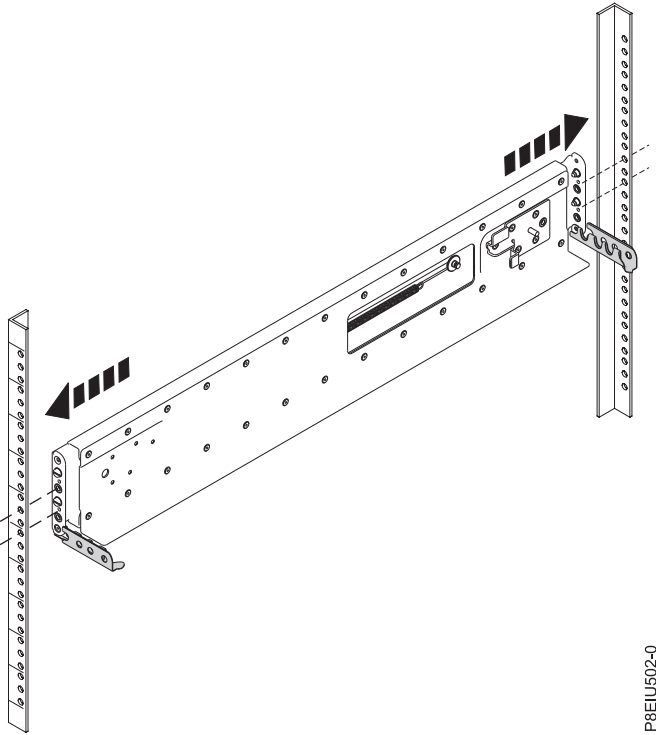

Figure 5. Mounting the rail on the rack

9. Close the front hinge bracket to secure the rail to the rack cabinet flange.

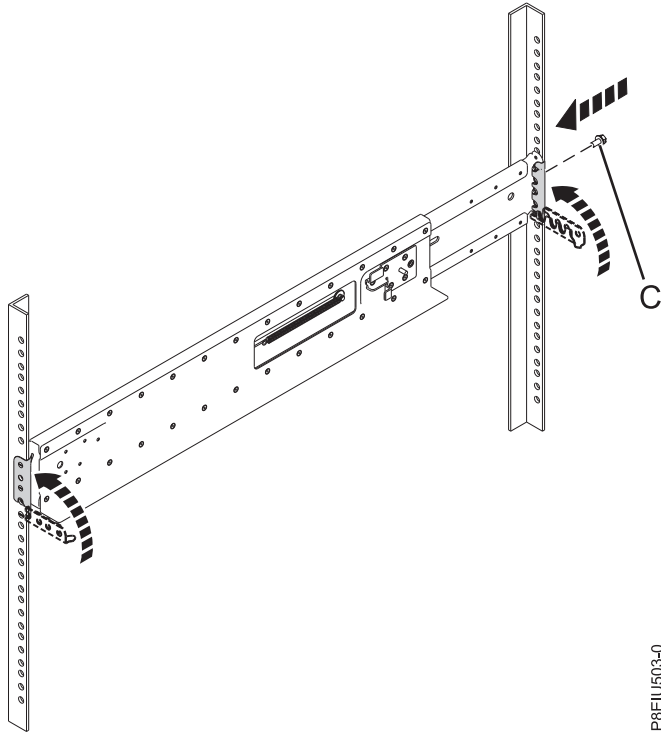

Figure 6. Securing the rail to the rack

10. At the rear of the rack, carefully retract the rail until it lines up with the rack flange and seat the pins in the marked mounting holes. Then, close the rear hinge bracket to secure the rail to the rack cabinet flange.
11. Install one M5 screw in the open hole in the bracket between the two alignment pins (C) at the rear of the rack.
12. Repeat this procedure for the other support rail.

---

## Installing the 5147-024, ESLL, or ESLS storage enclosure into a rack

To install the 5147-024, ESLL, or ESLS storage enclosure into a rack, complete the steps in this procedure. In addition to related safety information, illustrations of the related hardware components are provided.

**Important:** Two people are required to safely lift the enclosure. Using fewer than two people to lift the enclosure can result in injury.

1. Ensure that you have the electrostatic discharge (ESD) wrist strap attached. If not, attach it now.
2. Remove the left side cover (A) and right side cover (B) to show the mounting brackets. Pinch the release to rotate the cover up and off from the chassis flange as shown in Figure 7 on page 8.

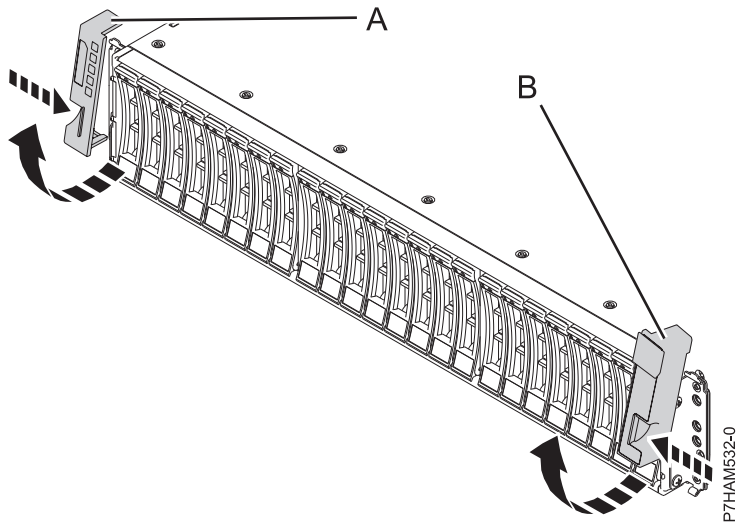

Figure 7. Removing the side covers

3. Using two people, lift the enclosure and position it over the front of the rails.
 

**Attention:** Two people are required to safely lift the enclosure. Using fewer than two people to lift the enclosure can result in injury.
4. Slide the enclosure into the rack cabinet. Ensure that the rear guide on the enclosure is seated in the enclosure stop on the support rail.

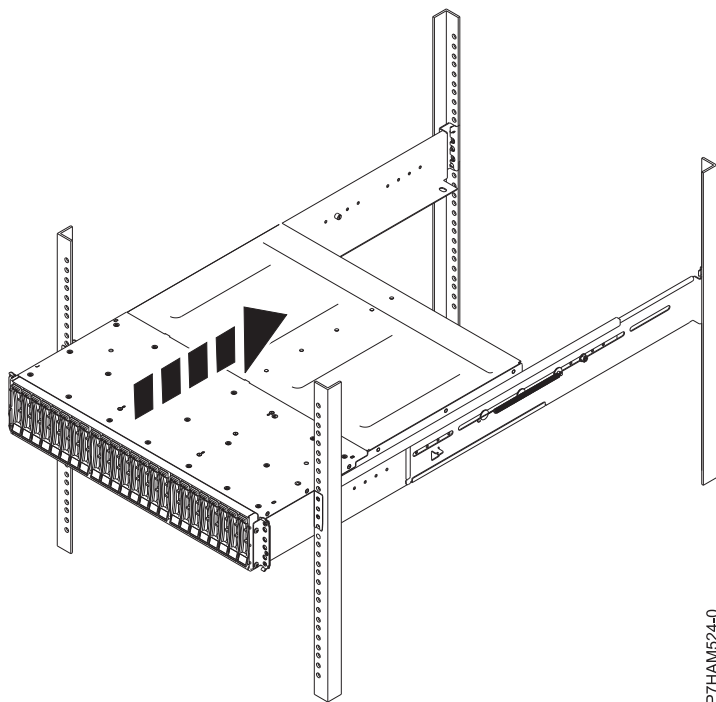

Figure 8. Sliding the enclosure into the rack

5. Secure the front of the enclosure to the rack flanges with one M5 screw (C) in the top open hole in each bracket.



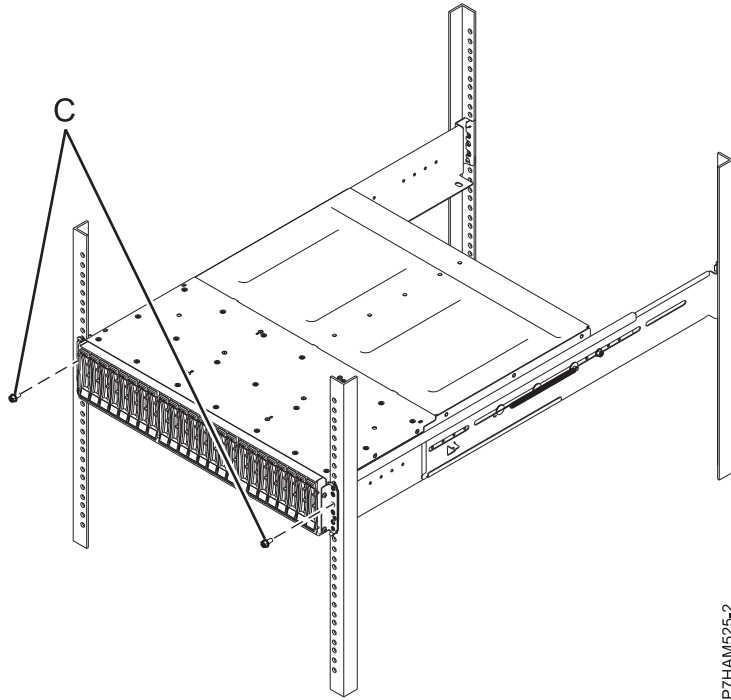

Figure 9. Securing the front of the enclosure to the rack

---

## Optional: Install disk drives or SSDs in the 5147-024, ESLL, or ESLS storage enclosure

To install disk drives or SSDs, complete the steps in this procedure.

### Notes:

- You can install disk drives in the ESLL storage enclosure.
  - You can install disk drives or solid-state drives (SSDs) in the ESLS storage enclosure.
  - You can install SSDs in the 5147-024 storage enclosure.
1. Ensure that you have the electrostatic discharge (ESD) wrist strap attached. If not, attach it now.
  2. Remove the drive from the static-protective package.  
**Attention:** Drives are fragile. Handle with care.
  3. With the handle in the unlocked position, support the bottom of the drive as you align it with the guide rails in the disk drive enclosure. See Figure 10 on page 10 or Figure 11 on page 10

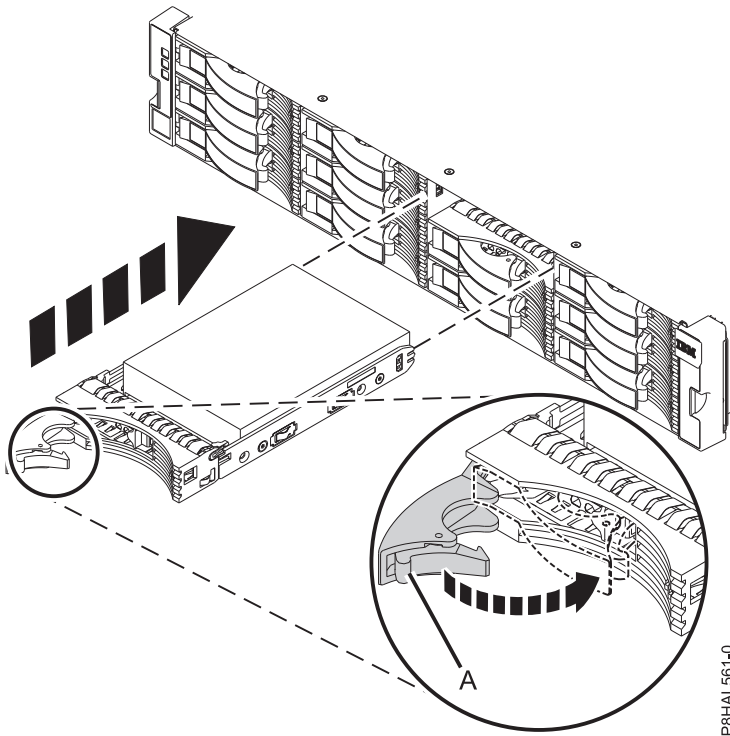

P8HAL561-0

Figure 10. Installing a disk drive in the ESLL storage enclosure

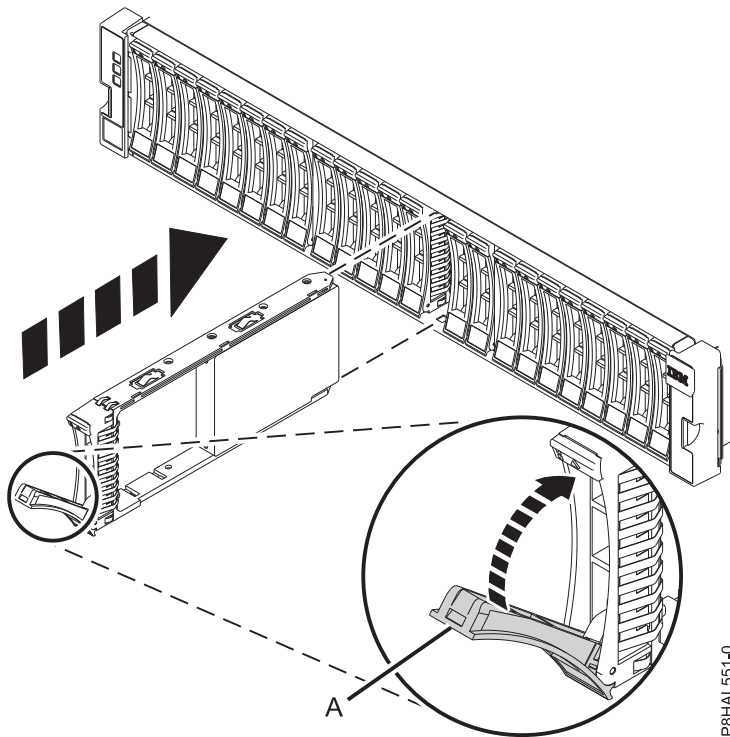

P8HAL551-0

Figure 11. Installing a drive in the 5147-024 or ESLS storage enclosure

**Note:** Do not hold the drive only by the handle.

4. Slide the drive into the enclosure until the drive stops.

5. Rotate the handle **(A)** to the locked position.
6. If you are installing more than one drive, repeat the steps in this procedure until all drives are installed.
7. Review the following information that is related to connecting this device:

The ESLL storage enclosure can hold up to 12 large form factor disk drives. The 5147-024 and ESLS storage enclosures can hold up to 24 small form factor drives. The storage enclosures can be split logically into one, two, or four independent groups.

The 5147-024, ESLL, or ESLS storage enclosure support the following operating systems:

- AIX® (The 5147-024 storage enclosure is not supported by AIX.)
- IBM i (The 5147-024 and ESLL storage enclosures are not supported by IBM i.)
- Linux
- VIOS (The 5147-024 storage enclosure is not supported by VIOS.)

If you are planning to configure RAID arrays, ensure that you have the minimum number of available disks for each RAID level:

**RAID 0**

Minimum of one drive per array.

**RAID 5**

Minimum of three drives per array.

**RAID 6**

Minimum of four drives per array.

**RAID 10**

Minimum of two drives per array.

---

## Connecting the 5147-024, ESLL, or ESLS storage enclosure to your system

Learn how to connect the 5147-024, ESLL, or ESLS storage enclosure to your system.

**Note:** The cables that are used to connect the 5147-024, ESLL, or ESLS storage enclosure to a server are different from the cables that are used with the 5887 disk drive enclosure.

To connect the 5147-024, ESLL, or ESLS storage enclosure to a system with support for a serial-attached SCSI (SAS) storage enclosure, complete the following steps.

For more information about SAS cabling and cabling configurations, see Serial-attached SCSI cable planning ([http://www.ibm.com/support/knowledgecenter/POWER8/p8had/p8had\\_sascabbling.htm](http://www.ibm.com/support/knowledgecenter/POWER8/p8had/p8had_sascabbling.htm)).

1. Ensure that you have the electrostatic discharge (ESD) wrist strap attached. If not, attach it now.
2. Confirm the factory-set mode of the enclosure by using information that is printed on stickers at the rear of the enclosure. Stickers are attached to the lower-left shelf of the chassis **(A)** and the center support between the enclosure services manager modules **(B)**. The stickers indicate whether the enclosure is set to mode 1, mode 2, or mode 4. For more information, see Figure 12 on page 12.

**Note:** The 5147-024 storage enclosure only supports mode 1.

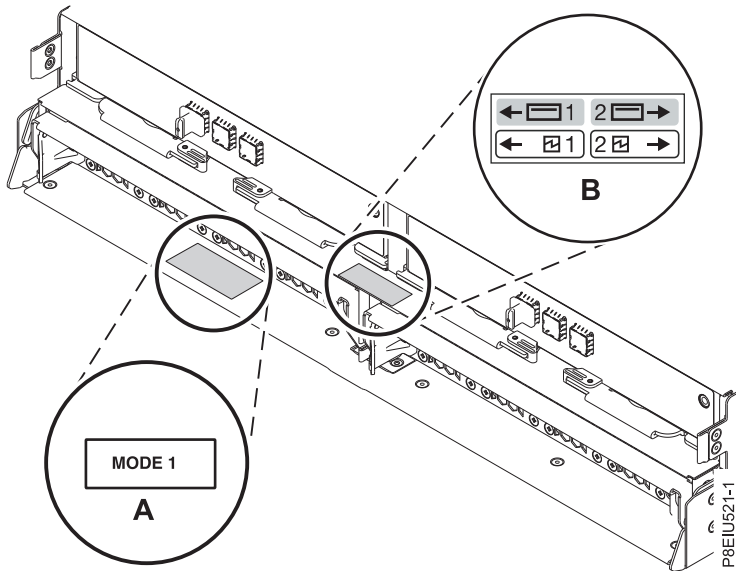

Figure 12. Mode sticker locations at the rear of the 5147-024, ESLL, or ESLS storage enclosure

3. Ensure that all adapters that you need to connect to the 5147-024, ESLL, or ESLS storage enclosure are installed in the system or expansion unit. If the adapters are not installed, complete the adapter installation procedure for your system or expansion unit before you continue with this task. For instructions, see PCIe adapters (<http://www.ibm.com/support/knowledgecenter/POWER8/p8hak/pciadapters.htm>).
4. If the system requires an internal cable to be installed to produce an external SAS port for connection with the enclosure, confirm that the installation was completed.

**Remember:** When you install or confirm the use of an external SAS port, record the location of the external SAS port on the system. Later in this procedure, you are instructed to install the external SAS cable to this system connector location.

5. Determine the configuration that you will use to cable the SAS adapter to the 5147-024, ESLL, or ESLS storage enclosure. The following list shows some of the common connections, but not all possible connection options. For more configuration options, see Planning for serial-attached SCSI cables ([http://www.ibm.com/support/knowledgecenter/POWER8/p8had/p8had\\_sascabling.htm](http://www.ibm.com/support/knowledgecenter/POWER8/p8had/p8had_sascabling.htm)).

**Notes:**

- The 5147-024 storage enclosure attaches to your system with AA12 cables (or other straight cables).
- The ESLL or ESLS storage enclosure attaches to your system with YO12 or X12 cables.
- If you use a YO12 cable to attach the ESLL or ESLS storage enclosure to the rear SAS ports of the system model 8247-21L, 8247-22L, 8247-42L, 8284-21A, 8284-22A, 8286-41A, or 8286-42A, the SAS YO12 cable must not exceed the maximum supported length of 3 m (9.8 ft).
- If you are working on a 5147-024, use a mode 1 connection by using two AA12 or other straight cables to two SAS adapters.
- A mode 1 connection of one ESLL or ESLS storage enclosure by using a YO12 cable to a single SAS adapter.
- A mode 1 connection of two ESLL or ESLS storage enclosures by using a YO12 cables to a single SAS adapter.
- A mode 1 connection of one ESLL or ESLS storage enclosure by using a YO12 cables to a SAS adapter pair.
- A mode 1 connection of two ESLL or ESLS storage enclosures by using a YO12 cables to a SAS adapter pair.

- A mode 2 connection of one ESLL or ESLS storage enclosure by using a YO12 cables to two independent SAS adapters.
  - A mode 2 connection of one ESLS storage enclosure by using X12 cables to two SAS adapter pairs.
  - A mode 4 connection of one ESLL or ESLS storage enclosure by using X12 cables to four independent SAS adapters.
6. Locate the connection for each adapter for which you are using an external SAS cable to connect the enclosure. Adapter cables attach to ports at the rear of the systems in which the adapters are installed. To identify the SAS port location for the system in your configuration, see “Connector locations” on page 30 and select the appropriate model.
  7. Select from the following options:
    - If the server or expansion unit that you are attaching your 5147-024, ESLL, or ESLS storage enclosure to is powered off, continue with step 12.
    - If the system is powered on, you must do one of the following actions, depending on the supported functions of your operating system:
      - Unconfigure the adapters to which you are connecting the enclosure.
      - Power off the adapters to which you are connecting the enclosure.
      - Power off the logical partitions or systems that own the adapters to which you are connecting the enclosure.
 To do one of these required actions, continue with step 8.
  8. Do the following conditions apply to your situation?
    - Your system model does not support slot power control.
    - Your adapters are not in an I/O enclosure that supports slot power control.
    - You are unable to tolerate a temporary loss of access to other disk devices that might exist on the same adapters.
      - **Yes:** Power off the system or the logical partitions that own the adapters by completing the steps in “Stopping a system or logical partition” on page 25. Then, continue with step 12.
      - **No:** Continue with step 9.
  9. Select from the following options:
    - If you can unconfigure the SAS adapters, go to step 10.
    - If you cannot unconfigure the SAS adapters, you need to power off the SAS adapters. Go to step 11.
  10. To unconfigure the SAS adapters, complete these steps:
    - a. Unconfigure the SAS adapters.
    - b. Ensure that you have the electrostatic discharge (ESD) wrist strap attached. If not, attach it now.
    - c. Connect the SAS cables from the enclosure to the SAS adapters.
    - d. Reconfigure the SAS adapters.
    - e. Continue with step 12.
  11. To power off the SAS adapters, complete these steps:
    - a. Power off the SAS adapters.
    - b. Ensure that you have the electrostatic discharge (ESD) wrist strap attached. If not, attach it now.
    - c. Connect the SAS cables from the enclosure to the SAS adapters.
    - d. Power on the SAS adapters.
    - e. Configure the SAS adapters and devices.
    - f. Continue with step 12.
  12. Choose one of the following options to cable the SAS adapter:

**Note:** The configuration figures show the use of SAS adapters to represent the external server or expansion unit connections. The adapter can represent one of the following connection types:

- The external port of an adapter that you confirmed in step 3 on page 12.
- The external port of an internal adapter cable that you confirmed in step 4 on page 12.

**Note:** Adapters are cabled to the enclosure by using ports at the rear of the enclosure. To learn about the enclosure ports that are used in the following options, see “Connector locations” on page 30.

- To complete a mode 1 connection of one 5147-024 storage enclosure by using two AA12 or other straight cables to two adapters in a 5148-22L system, continue with step 13.
- To complete a mode 1 connection of one ESLL or ESLS storage enclosure by using a YO12 cable to a single FC EJ0J or FC EJ0M SAS adapter, go to step 14 on page 15.
- To complete a mode 1 connection of two ESLL and ESLS storage enclosures by using a YO12 cables to a single FC EJ0J or FC EJ0M SAS adapter, go to step 15 on page 15.
- To complete a mode 1 connection of one ESLL or ESLS storage enclosure by using a YO12 cables to an FC EJ0L SAS adapter pair or an FC EJ14 SAS adapter pair, go to step 16 on page 16.
- To complete a mode 1 connection of two ESLL and ESLS storage enclosures by using a YO12 cables to an EJ0L SAS adapter pair or an FC EJ14 SAS adapter pair, go to step 17 on page 17.
- To complete a mode 2 connection of one ESLL or ESLS storage enclosure by using a YO12 cables to two independent FC EJ0J or FC EJ0M SAS adapters, go to step 18 on page 18.
- To complete a mode 2 connection of one ESLS storage enclosure by using X12 cables to two FC EJ0L SAS adapter pairs or two FC EJ14 pairs, go to step 19 on page 19.
- To complete a mode 4 connection of one ESLL or ESLS storage enclosure by using X12 cables to four independent FC EJ0J or FC EJ0M SAS adapters, go to step 20 on page 20.

If your SAS configuration requirements are not supported by any of these options, go to step 21 on page 22.

13. Complete a mode 1 connection of one 5147-024 storage enclosure (**A**) by using two AA12 or other straight cables (**B**) to two adapters (**C, D**), as shown in Figure 13, and then continue with “Connecting cables, power cords, and installing covers” on page 22.

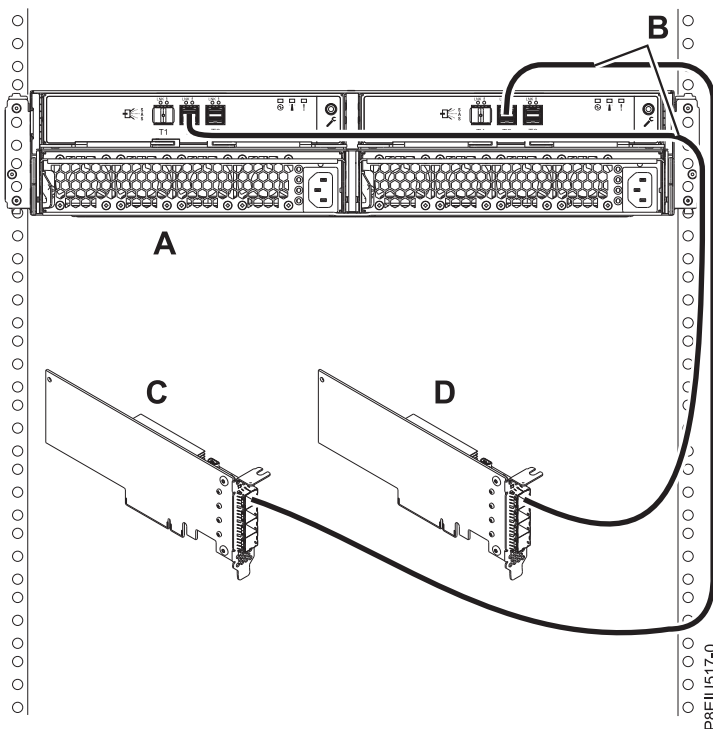

Figure 13. Mode 1 connection of one 5147-024 enclosure by using two AA12 or other straight cables to two adapters

- Complete a mode 1 connection of one enclosure (**A**) by using a YO12 cable (**B**) to a single FC EJ0J or FC EJ0M SAS adapter (**C**), as shown in Figure 14, then continue with “Connecting cables, power cords, and installing covers” on page 22.

**Note:** The single FC EJ0J or FC EJ0M SAS adapter (**C**) has access to all 12 or 24 drive bays.

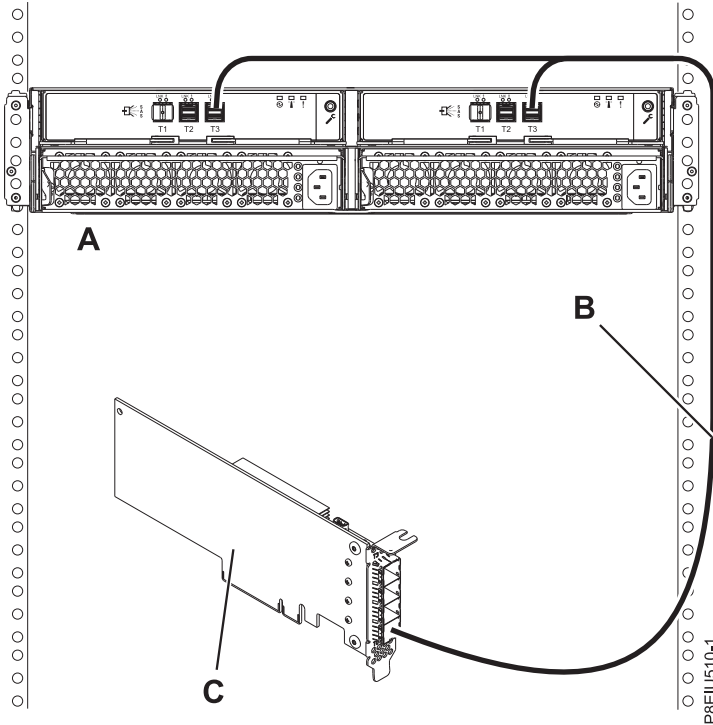

Figure 14. Mode 1 connection of one ESLL or ESLS storage enclosure by using a YO12 cable to a single FC EJ0J or FC EJ0M SAS adapter

- Complete a mode 1 connection of two enclosures (**A and B**) by using YO12 cables (**C and D**) to a single FC EJ0J or FC EJ0M SAS adapter (**E**), as shown in Figure 15 on page 16, and then continue with “Connecting cables, power cords, and installing covers” on page 22.

**Note:** The single SAS adapter (**E**) has access to all 24 or 48 drive bays.

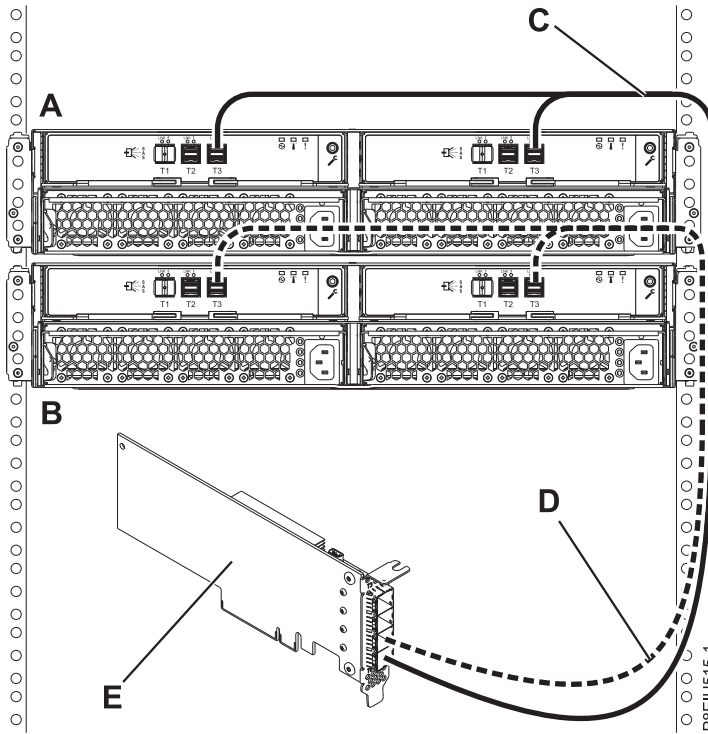

Figure 15. Mode 1 connection of two ESLL and ESLS storage enclosures by using YO12 cables to a single FC EJ0J or FC EJ0M SAS adapter

16. Complete a mode 1 connection of one enclosure (A) by using YO12 cables (B) to an FC EJ0L SAS adapter pair or an FC EJ14 SAS adapter pair (C) with adapter-to-adapter (AA) cables (D), as shown in Figure 16 on page 17, and then continue with “Connecting cables, power cords, and installing covers” on page 22.

**Notes:**

- Each adapter in the SAS adapter pair (C) has access to the other adapter and to all 12 or 24 drive bays.
- For SAS adapter pairs, you must attach the cables to the same port on both adapters.
- Both short legs of the cables must attach to the same side of the enclosure and both long legs of the cable must attach to the other side of the enclosure.



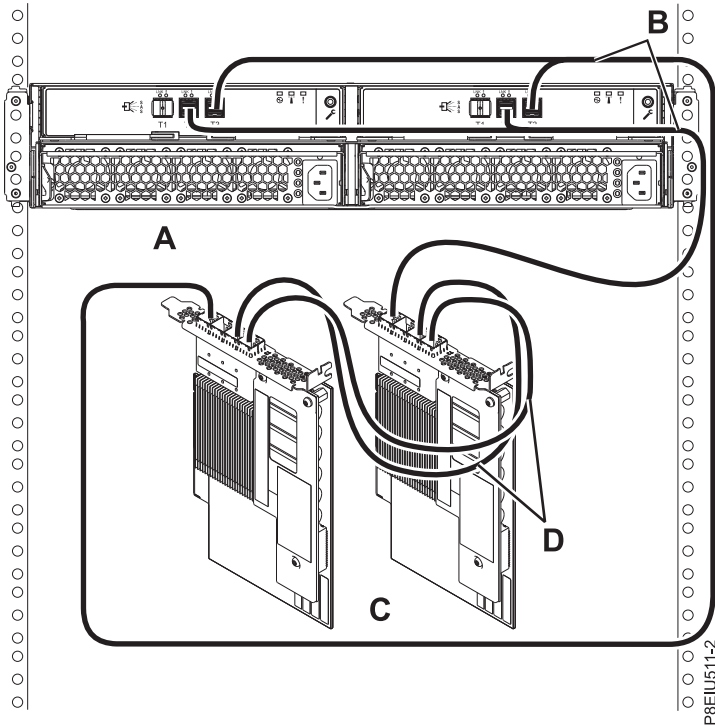

Figure 16. Mode 1 connection of one ESSL or ESLS storage enclosure by using YO12 cables to an FC EJ0L SAS adapter pair or an FC EJ14 SAS adapter pair with AA cables

- Complete a mode 1 connection of two enclosures (**A and B**) by using YO12 cables (**C and D**) to an FC EJ0L SAS adapter pair or an FC EJ14 SAS adapter pair (**E**) with AA cables (**F**), as shown in Figure 17 on page 18, and then continue with “Connecting cables, power cords, and installing covers” on page 22.

**Notes:**

- Each adapter in the SAS adapter pair (**C**) has access to the other adapter and to all 24 or 48 drive bays.
- For SAS adapter pairs, you must attach the cables to the same port on both adapters.
- Both short legs of the cables must attach to the same side of the enclosure and both long legs of the cable must attach to the other side of the enclosure.

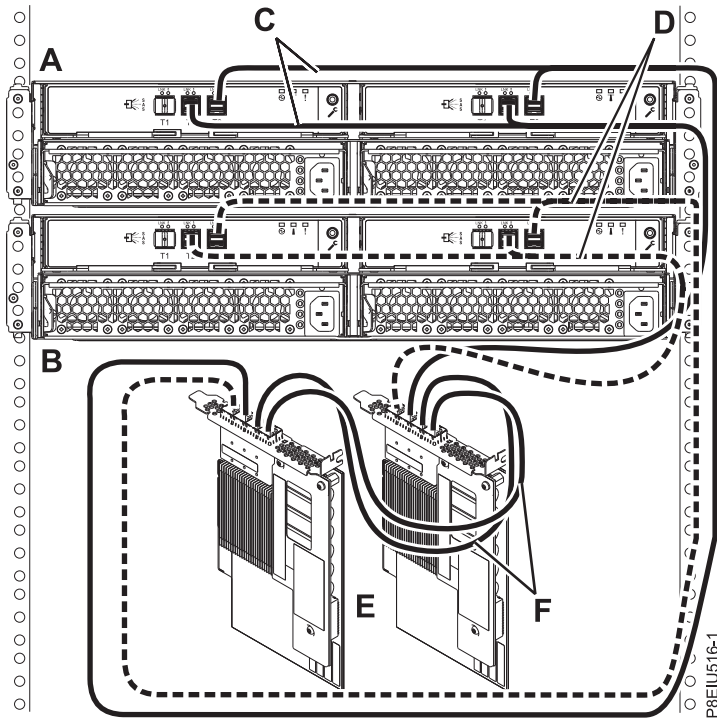

Figure 17. Mode 1 connection of two ESLL and ESLS storage enclosures by using YO12 cables to an FC EJ0L SAS adapter pair or an FC EJ14 SAS adapter pair with AA cables

18. Complete a mode 2 connection of one enclosure (A) by using YO12 cables (B) to two independent FC EJ0J or FC EJ0M SAS adapters, as shown in Figure 18 on page 19, and then continue with "Connecting cables, power cords, and installing covers" on page 22.

**Notes:**

- Independent SAS adapter 1 (C) does not have access to the other independent adapter and has access only to drive bays D1 - D12.
- Independent SAS adapter 2 (D) does not have access to the other independent adapter and has access only to drive bays D13 - D24.

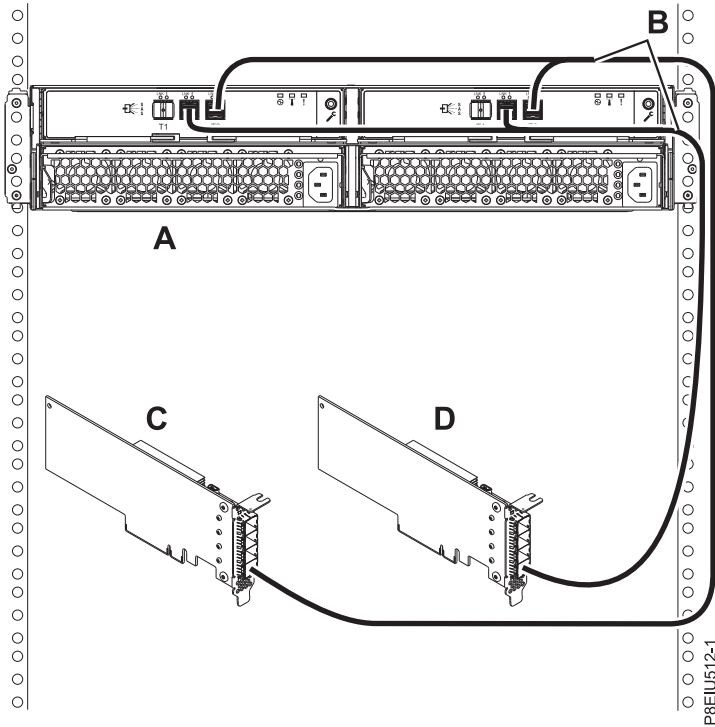

Figure 18. Mode 2 connection of one ESLL or ESLS storage enclosure by using YO12 cables to two independent FC EJ0J or FC EJ0M SAS adapters

- Complete a mode 2 connection of one enclosure (A) by using X12 cables (B) to two FC EJ0L SAS adapter pairs or two FC EJ14 SAS adapter pairs (C, D) with AA cables (E), as shown in Figure 19 on page 20, and then continue with “Connecting cables, power cords, and installing covers” on page 22.

**Notes:**

- Each adapter in the SAS adapter pair 1 (C) has access to the other adapter in pair 1 and to drive bays D1 - D12.
- Each adapter in the SAS adapter pair 2 (D) has access to the other adapter in pair 2 and to drive bays D13 - D24.
- For SAS adapter pairs, you must attach the cables to the same port on both adapters.
- Both short legs of the cables must attach to the same side of the enclosure and both long legs of the cable must attach to the other side of the enclosure.

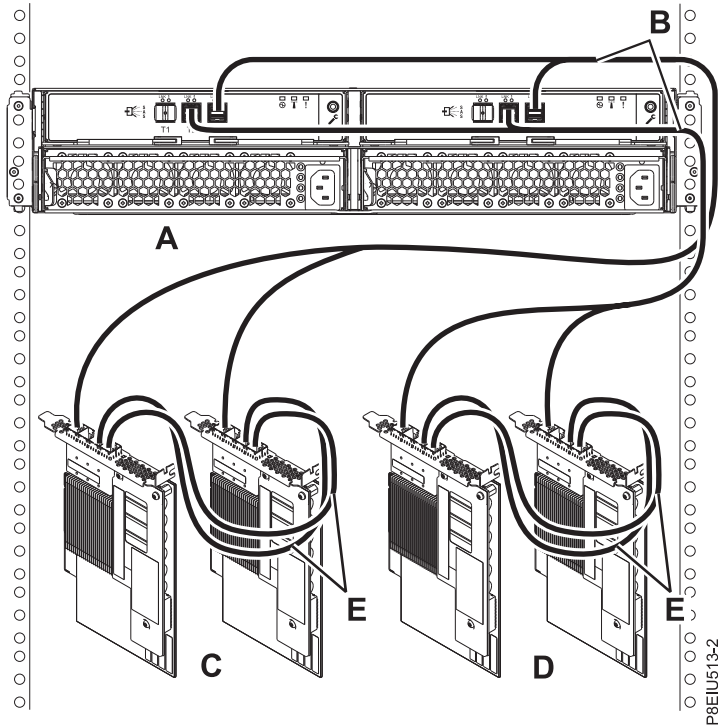

Figure 19. Mode 2 connection of one ESLS by using X12 cables to two FC EJ0L SAS adapter pairs or two FC EJ14 SAS adapter pairs with AA cables

- Complete a mode 4 connection of one enclosure (A) by using X12 cables (B) to four independent FC EJ0J or FC EJ0M SAS adapters, as shown in Figure 20 on page 21, and then continue with "Connecting cables, power cords, and installing covers" on page 22.

**Note:** Refer to Figure 21 on page 21 for label examples of these cable identifiers.

- The cable that plugs into independent SAS adapter 1 (C) contains a label with the P1 identifier (G). This adapter does not have access to any other independent adapter and has access only to drive bays D1 - D6 (D1 - D3 for the ESLL).
- The cable that plugs into independent SAS adapter 2 (D) contains a label with the P2 identifier (G). This adapter does not have access to any other independent adapter and has access only to drive bays D7 - D12 (D4 - D6 for the ESLL).
- The cable that plugs into independent SAS adapter 3 (E) contains a label with the P1 identifier (G). This adapter does not have access to any other independent adapter and has access only to drive bays D13 - D18 (D7 - D9 for the ESLL).
- The cable that plugs into independent SAS adapter 4 (F) contains a label with the P2 identifier (G). This adapter does not have access to any other independent adapter and has access only to drive bays D19 - D24 (D10 - D12 for the ESLL).

**Note:** Partial mode 4 configurations are supported with less than 4 adapters leaving an adapter end of the X12 cable not connected.

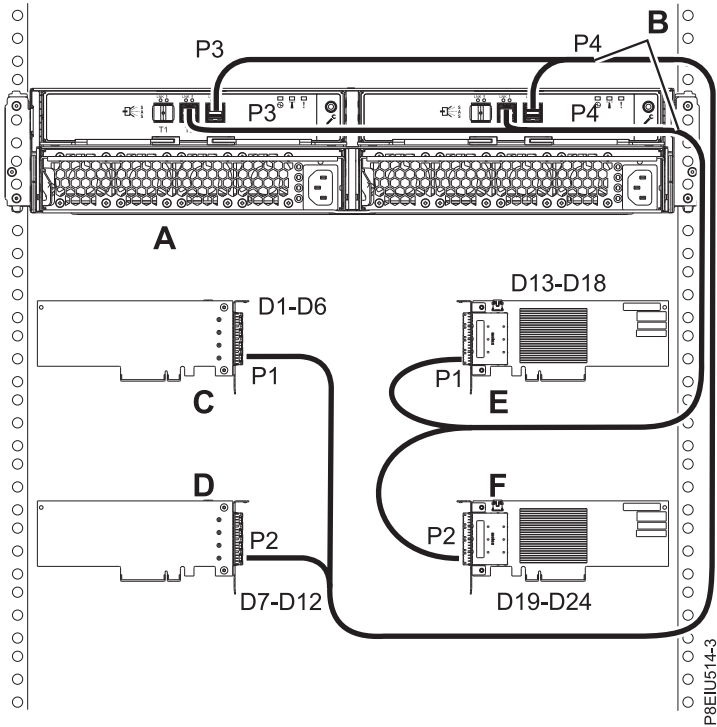

Figure 20. Mode 4 connection of one ESLL or ESLS storage enclosure by using X12 cables to four independent FC EJ0J or FC EJ0M SAS adapters

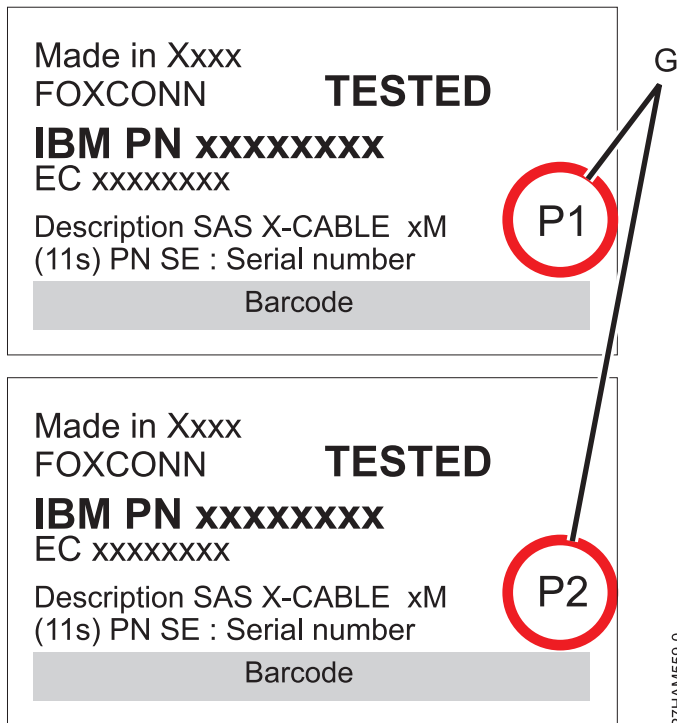

Figure 21. Labels for SAS adapter cables that show P1 and P2 identifiers

21. For more information about SAS cabling and cabling configurations, see Serial-attached SCSI cable planning ([http://www.ibm.com/support/knowledgecenter/POWER8/p8had/p8had\\_sascabbling.htm](http://www.ibm.com/support/knowledgecenter/POWER8/p8had/p8had_sascabbling.htm)).

---

## Connecting cables, power cords, and installing covers

Use this procedure to reconnect cables, power cords, and install the side covers.

To reconnect cables, attach power cords, and install the side covers, complete the following steps:

1. Ensure that you have the electrostatic discharge (ESD) wrist strap attached. If not, attach it now.
2. If your installation requirements included the removal of the SAS cables from the ESMs, review the labeling that you completed and reinstall the cables.

**Note:** Do not apply power until instructed to do so.

3. Route the power cords through the power cord retention brackets (**D**) for strain relief, as shown in the following figure.

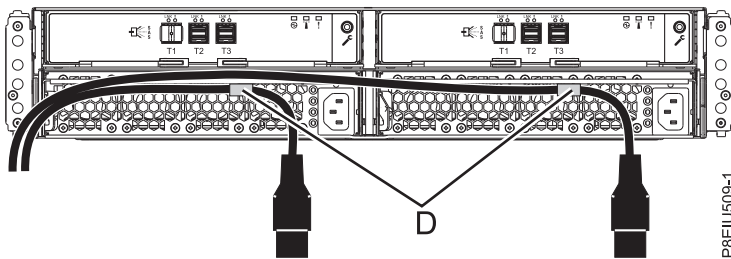
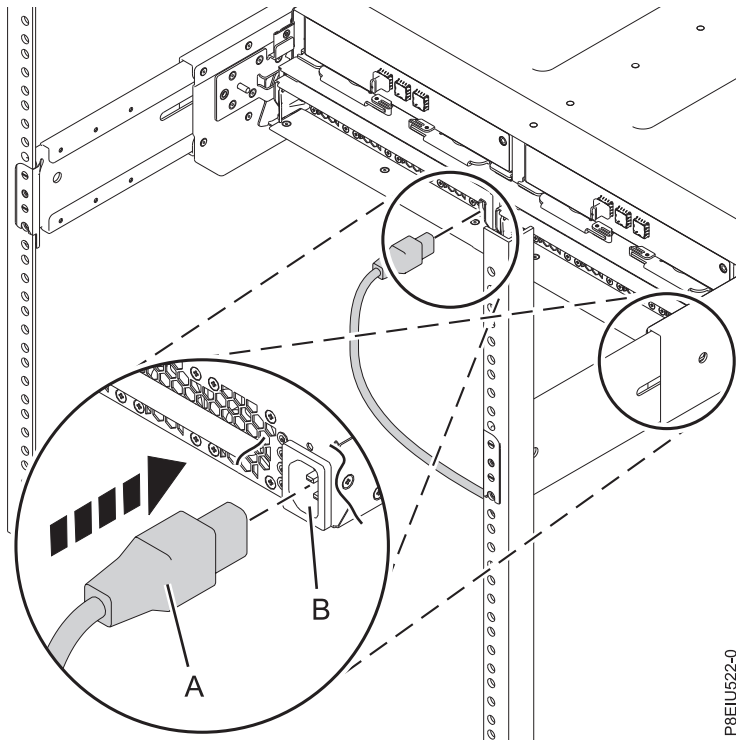

Figure 22. Routing the power cords through the cord retention brackets

4. Connect the power cords to the left and right power supplies.



P8EIU522-0

Figure 23. Connecting the power cords

5. Reinstall the left cover (A), which contains the service indicators, and the right cover (B).
  - a. Fit the slot on the top of the cover over the tab on the chassis flange.
  - b. Rotate the cover down until it snaps into place. Ensure that the inside surface of the cover is flush with the chassis.

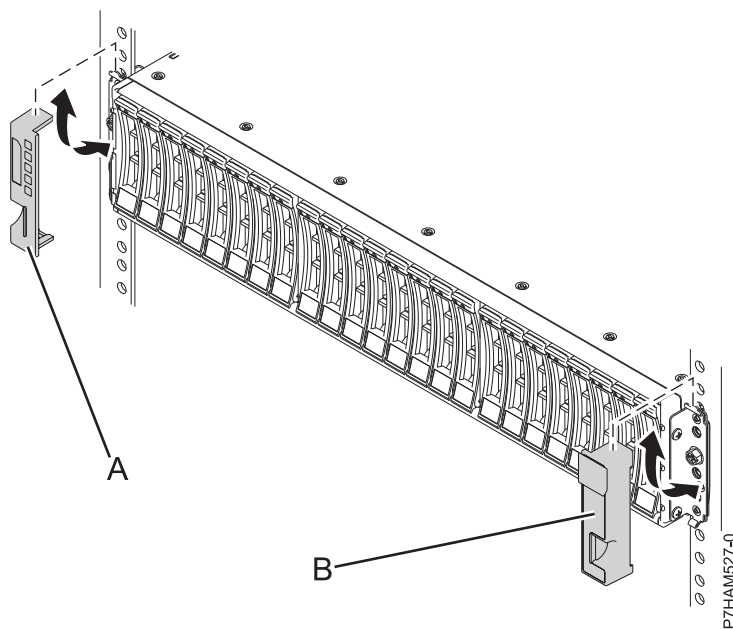

P7HAM527-0

Figure 24. Attaching the side covers

6. Connect the other end of the power cables to the power distribution units (PDUs).

7. If you powered down either the system or the partition before you connected the storage enclosure cables to it, power on the system or partition. If you did not power down the system or partition, depending on the option you chose in the beginning of this procedure, you might need to reconfigure the adapters.

---

## Completing the 5147-024, ESSL, or ESLS storage enclosure installation

Learn how to complete the installation process.

To complete the installation process, complete the following steps:

1. To learn how to add the disk drives to the operating system, see the following information:
  - To configure a disk drive or SSD for use by AIX, see *Configuring a disk drive or solid-state drive for use in an AIX system or AIX logical partition* ([http://www.ibm.com/support/knowledgecenter/POWER8/p8hal/pxhal\\_configdrive\\_aix.htm](http://www.ibm.com/support/knowledgecenter/POWER8/p8hal/pxhal_configdrive_aix.htm)).
  - To configure a disk drive or SSD for use by IBM i, see *Configuring a disk drive or solid-state drive for use in an IBM i system or IBM i logical partition* ([http://www.ibm.com/support/knowledgecenter/POWER8/p8hal/pxhal\\_configdrive\\_ibmi.htm](http://www.ibm.com/support/knowledgecenter/POWER8/p8hal/pxhal_configdrive_ibmi.htm)).
  - To configure a disk drive or SSD for use by Linux, see *Configuring a disk drive or solid-state drive for use in an Linux system or Linux logical partition* ([http://www.ibm.com/support/knowledgecenter/POWER8/p8hal/pxhal\\_configdrive\\_linux.htm](http://www.ibm.com/support/knowledgecenter/POWER8/p8hal/pxhal_configdrive_linux.htm)).
2. To verify that the system or logical partition recognizes the disk drive enclosure, see *Verifying the installed part* ([http://www.ibm.com/support/knowledgecenter/POWER8/p8haj/pxhaj\\_hsmverify.htm](http://www.ibm.com/support/knowledgecenter/POWER8/p8haj/pxhaj_hsmverify.htm)).
3. You have completed the steps to install the 5147-024, ESSL, or ESLS storage enclosure. If you were directed here from another procedure, return to that procedure now.



---

## Reference information

Use the information in this section as needed to complete the storage enclosure installation and configuration tasks.

---

### Stopping a system or logical partition

Learn how to stop a system or logical partition as a part of a system upgrade or service action.

**Attention:** Using either the power-on button on the control panel or entering commands at the Hardware Management Console (HMC) to stop the system can cause unpredictable results in the data files. Also, the next time you start the system, it might take longer if all applications are not ended before stopping the system.

To stop the system or logical partition, select the appropriate procedure.

### Stopping a system that is not managed by an HMC

You might need to stop the system to complete another task. If your system is not managed by the Hardware Management Console (HMC), use these instructions to stop the system by using the power button or the Advanced System Management Interface (ASMI).

Before you stop the system, follow these steps:

1. Ensure that all jobs are completed and end all applications.
2. If a Virtual I/O Server (VIOS) logical partition is running, ensure that all clients are shut down or that the clients have access to their devices by using an alternative method.

### Stopping a system by using the control panel

You might need to stop the system to complete another task. If your system is not managed by the Hardware Management Console (HMC), use these instructions to stop the system by using the power button.

The following procedure describes how to stop a system that is not managed by the HMC.

1. Log in to the host partition as a user with the authority to run the **shutdown** or **pwrdownsys** (Power Down System) command.
2. At the command line, enter one of the following commands:
  - If your system is running the AIX operating system, type **shutdown**.
  - If your system is running the Linux operating system, type **shutdown -h now**.
  - If your system is running the IBM i operating system, type **PWRDWN SYS**. If your system is partitioned, use the **PWRDWN SYS** command to power down each of the secondary partitions. Then, use the **PWRDWN SYS** command to power down the primary partition.

The command stops the operating system. The system power turns off, the power-on light begins to slowly flash, and the system goes into a standby state.

3. Record the IPL type and the IPL mode from the control panel display to help you return the system to this state when the installation or replacement procedure is completed.
4. Set the power switches of any devices that are connected to the system to off.

### Stopping a system by using the ASMI

You might need to stop the system to complete another task. If your system is not managed by the Hardware Management Console (HMC), use these instructions to stop the system by using the Advanced System Management Interface (ASMI).

To stop a system by using the ASMI, complete the following steps:

1. On the ASMI Welcome pane, specify your user ID and password, and click **Log In**.
2. In the navigation area, click **Power/Restart Control > Power On/Off System**. The power state of the system is displayed.
3. Specify the settings as required and click **Save setting and power off**.

## Stopping a system by using the HMC

You can use the Hardware Management Console (HMC) to stop the system or logical partition.

By default, the managed system is set to power off automatically when you shut down the last running logical partition on the managed system. If you set the managed system properties on the HMC so that the managed system does not power off automatically, you must use this procedure to power off your managed system.

**Attention:** Ensure that you shut down the running logical partitions on the managed system before you power off the managed system. Powering off the managed system without shutting down the logical partitions first causes the logical partitions to shut down abnormally and can cause data loss. If you use a Virtual I/O Server (VIOS) logical partition, ensure that all clients are shut down or that the clients have access to their devices by using an alternative method.

To power off a managed system, you must be a member of one of the following roles:

- Super administrator
- Service representative
- Operator
- Product engineer

**Note:** If you are a product engineer, verify that the customer has shut down all active partitions and has powered off the managed system. Continue with the procedure only after the status of the server changes to **Power Off**.

## Stopping a system by using the HMC Classic or HMC Enhanced interface

Learn how to stop a system by using the HMC Classic or HMC Enhanced interface.

To stop the system or logical partition by using the HMC Classic or HMC Enhanced interface, complete the following steps:

1. In the navigation area, click **Systems Management > Servers**.
2. In the content pane, select the managed system.
3. In the Tasks area, click **Operations > Power Off**.
4. Select the appropriate power-off mode and click **OK**.

**Related information:**

 Shutting down and restarting logical partitions

## Stopping a system by using the HMC Enhanced + Tech Preview (Pre-GA) or HMC Enhanced+ interface

Learn how to stop a system by using the HMC Enhanced + Tech Preview (Pre-GA) or HMC Enhanced+ interface.

To stop the system or logical partition by using the HMC Enhanced + Tech Preview (Pre-GA) or HMC Enhanced+ interface, complete the following steps:

1. You must deactivate all the active logical partitions before powering off the system. To deactivate logical partitions for a specific system, complete the following steps:



- a. In the navigation area, click the **Resources** icon , and then click **All Systems**.
  - b. Click the system name for which you want to deactivate partitions.
  - c. Select the logical partitions that you want to deactivate.
  - d. In the content pane, click **Actions > Deactivate**.
  - e. Click **OK**.
2. To power off the system, complete the following steps:



- a. In the navigation area, click the **Resources** icon , and then click **All Systems**.
- b. Select the system that you want to power off.
- c. In the content pane, click **Actions > View All Actions > Power Off**.
- d. Click **OK**.

## Stopping an IBM PowerKVM system

You can use the Intelligent Platform Management Interface (IPMI) to stop an IBM PowerKVM system.

To stop an IBM PowerKVM system, complete the following steps:

1. Log in to the host as a root user or with sudo authority.
2. To power off each of the guests, complete the following steps.
  - a. To obtain a list of all guests, type **virsh list**.
  - b. For each guest in the list, type **virsh shutdown domain name** or type **virsh shutdown domain ID**.

### Note:

Type **virsh list** to verify whether all the guests are powered off. If any guest is not powered off, type **virsh destroy domain name** or type **virsh destroy domain ID** to power off the guest.

3. Run the **ipmitool -I lanplus -H FSP IP -P ipmipassword chassis power off** command from a remote system.

---

## Starting the system or logical partition

Learn how to start a system or logical partition after performing a service action or system upgrade.

### Starting a system that is not managed by an HMC

You can use the power button or the Advanced System Management Interface (ASMI) to start a system that is not managed by a Hardware Management Console (HMC).

### Starting a system by using the control panel

You can use the power button on the control panel to start a system that is not managed by a Hardware Management Console (HMC).

To start a system by using the control panel, complete the following steps:

1. Open the front rack door, if necessary.
2. Before you press the power button on the control panel, ensure that power is connected to the system unit as follows:
  - All system power cables are connected to a power source.
  - The power LED, as shown in the following figure, is slowly flashing.
  - The top of the display, as shown in the following figure, shows 01 V=F.

3. Press the power button (**A**), as shown in the following figure, on the control panel.

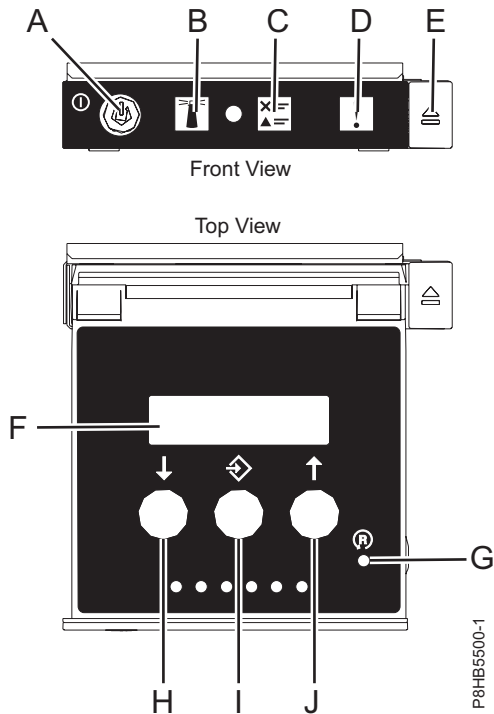

Figure 25. Control panel

- **A:** Power-on button
    - A constant light indicates full system power to the unit.
    - A flashing light indicates standby power to the unit.
    - There is approximately a 30-second transition period from the time the power-on button is pressed to when the power LED goes from flashing to solid. During the transition period, the LED might flash faster.
  - **B:** Enclosure identify light
    - A constant light indicates the identify state, which is used to identify a part.
    - No light indicates that the system is operating normally.
  - **C:** System information light
    - No light indicates that the system is operating normally.
    - Light on indicates that the system requires attention.
  - **D:** Enclosure fault roll-up light
    - A constant light indicates a fault in the enclosure.
    - No light indicates that the system is operating normally.
  - **E:** Eject button
  - **F:** Function/Data display
  - **G:** Pinhole reset button
  - **H:** Decrement button
  - **I:** Enter button
  - **J:** Increment button
4. Observe the following aspects after pressing the power button:
- The power-on light begins to flash faster.

- The system cooling fans are activated after approximately 30 seconds and begin to accelerate to operating speed.
- Progress indicators, also referred to as checkpoints, appear on the control panel display while the system is being started. The power-on light on the control panel stops flashing and remains on, indicating that the system power is on.

**Tip:** If pressing the power button does not start the system, then contact your next level of support or your service provider.

### Starting a system by using the ASMI

You can use the Advanced System Management Interface (ASMI) to start a system that is not managed by a Hardware Management Console (HMC).

To start a system by using the ASMI, complete the following steps:

1. On the ASMI Welcome pane, specify your user ID and password, and click **Log In**.
2. In the navigation area, click **Power/Restart Control > Power On/Off System**. The power state of the system is displayed.
3. Specify the settings as required and click **Save setting and power on**.

### Starting a system or logical partition by using the HMC

You can use the Hardware Management Console (HMC) to start the system or logical partition after the required cables are installed and the power cables are connected to a power source.

### Starting a system or logical partition by using the HMC Classic or HMC Enhanced interface

Learn how to start a system or logical partition by using the HMC Classic or HMC Enhanced interface.

To start the system by using the HMC Classic or HMC Enhanced interface, complete the following steps:

1. Verify that the logical partition start policy is set to **User-Initiated** by completing the following steps:
  - a. In the navigation area, expand **Systems Management > Servers**.
  - b. In the content pane, select the managed system.
  - c. In the Tasks area, click **Properties**.
  - d. Click the **Power-On Parameters** tab. Ensure that the **Partition start policy** field is set to **User-Initiated**.
2. Power on the managed system by completing the following steps:
  - a. In the navigation area, expand **Systems Management > Servers**.
  - b. In the content pane, select the managed system.
  - c. Click **Operations > Power on**.
  - d. Select the power-on option and click **OK**.

### Starting a system or logical partition by using the HMC Enhanced + Tech Preview (Pre-GA) or HMC Enhanced+ interface

Learn how to start a system or logical partition by using the HMC Enhanced + Tech Preview (Pre-GA) or HMC Enhanced+ interface.

To start a system or logical partition by using the HMC Enhanced + Tech Preview (Pre-GA) or HMC Enhanced+ interface, complete the following steps:

1. To power on the managed system, complete the following steps:

- a. In the navigation area, click the **Resources** icon  , and then click **All Systems**.

- b. Select the system that you want to power on.
  - c. In the content pane, click **Actions > View All Actions > Power On**.
  - d. Click **OK**.
2. To activate a logical partition, complete the following steps:



- a. In the navigation area, click the **Resources** icon , and then click **All Partitions**.
  - b. Click the logical partition name that you want to activate.
  - c. In the navigation area, click **Partition Actions > Operations > Activate**.
  - d. Click **OK**.
3. To activate a logical partition for a specific system, complete the following steps:



- a. In the navigation area, click the **Resources** icon , and then click **All Systems**.
  - b. Click the system name in which you want to activate the logical partition.
  - c. Select logical partitions that you want to activate.
  - d. In the content pane, click **Actions > Activate**.
  - e. Click **OK**.
4. To verify that the logical partition start policy is set to **User-Initiated**, complete the following steps:



- a. In the navigation area, click the **Resources** icon , and then click **All Systems**.
- b. Click the system name to view details.
- c. In the navigation area, click **Properties > Other Properties**.
- d. Click the **Power-On Parameters** tab. Ensure that the **Partition start policy** field is set to **User-Initiated**.

## Starting an IBM PowerKVM system

You can use the Intelligent Platform Management Interface (IPMI) to start an IBM PowerKVM system.

To start an IBM PowerKVM system, run the `ipmitool -I lanplus -H FSP IP -P ipmipassword chassis power on` command from a remote system.

---

## Connector locations

Learn about connector locations for the ESLL and ESLS storage enclosures and the servers that they connect to.

Choose from the following options:

- “Connector locations for the 5147-024, ESLL, and ESLS storage enclosures” on page 31
- Connector locations for the 247-21L, 8247-22L, and 8284-22A systems
- Connector locations for the 8286-41A system Connector locations for the 8286-42A system
- “Connector locations for the 8247-42L and 8286-42A systems” on page 32
- Connector locations for the 8408-44E and 8408-E8E systems
- Connector locations for the 9080-MHE, 9080-MME, 9119-MHE, and 9119-MME systems

## Connector locations for the 5147-024, ESSL, and ESLS storage enclosures

Learn about connector locations for the 5147-024, ESSL, and ESLS storage enclosures.

**Note:** The T1 connectors are not used.

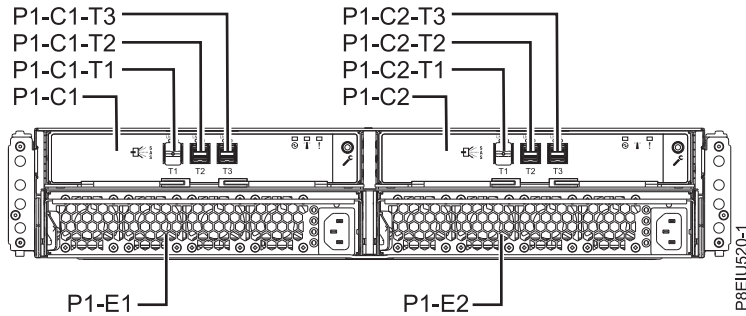

Figure 26. Connector locations for the 5147-024, ESSL, and ESLS storage enclosures

## Connector locations for the 5148-22L, 8247-21L, 8247-22L, 8284-21A, and 8284-22A systems

Learn about connector locations for the 5148-22L, 8247-21L, 8247-22L, 8284-21A, and 8284-22A systems.

The expanded function 5148-22L, 8247-21L, 8247-22L, 8284-21A, and 8284-22A servers provide cable connector locations via a SAS port for disk drive enclosures.

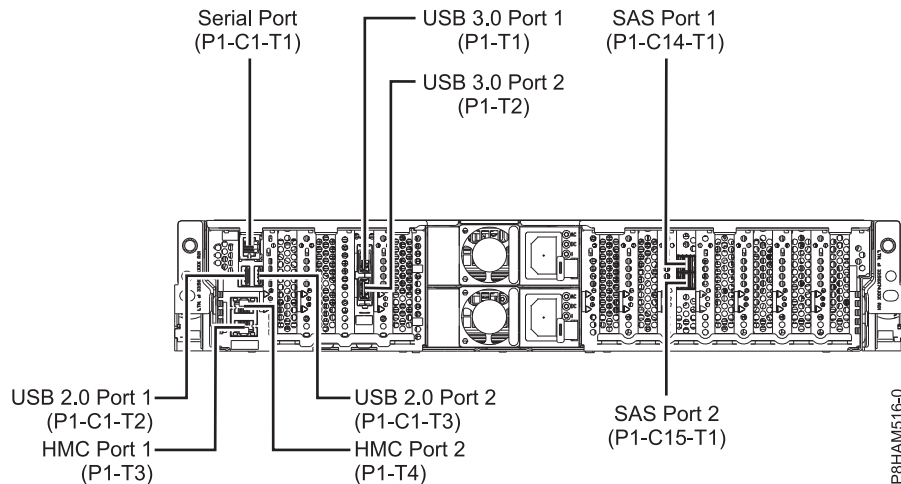

Figure 27. Connector locations for the expanded function 5148-22L, 8247-21L, 8247-22L, 8284-21A, and 8284-22A systems

## Connector locations for the 8286-41A system

Learn about connector locations for the 8286-41A rack-mounted and stand-alone models.

The 8286-41A server provides cable connector locations via a SAS port for disk drive enclosures.

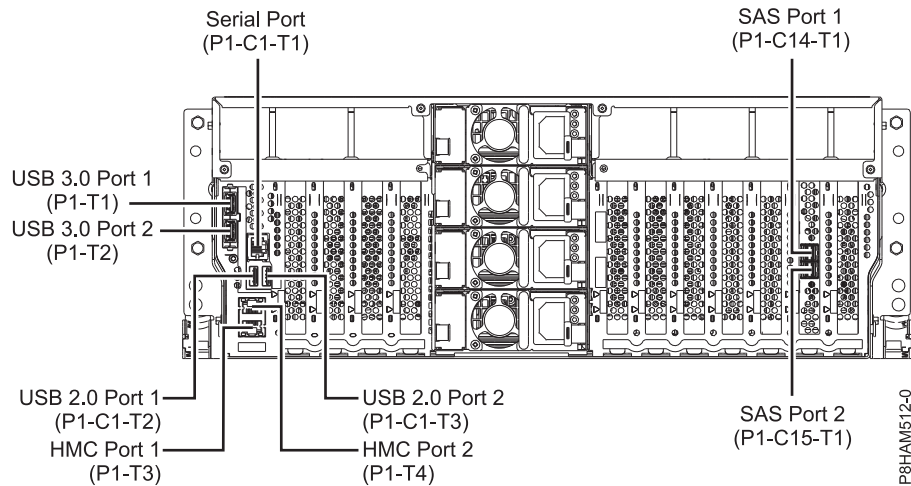

Figure 28. Connector locations for the rack-mounted 8286-41A (expanded function) system

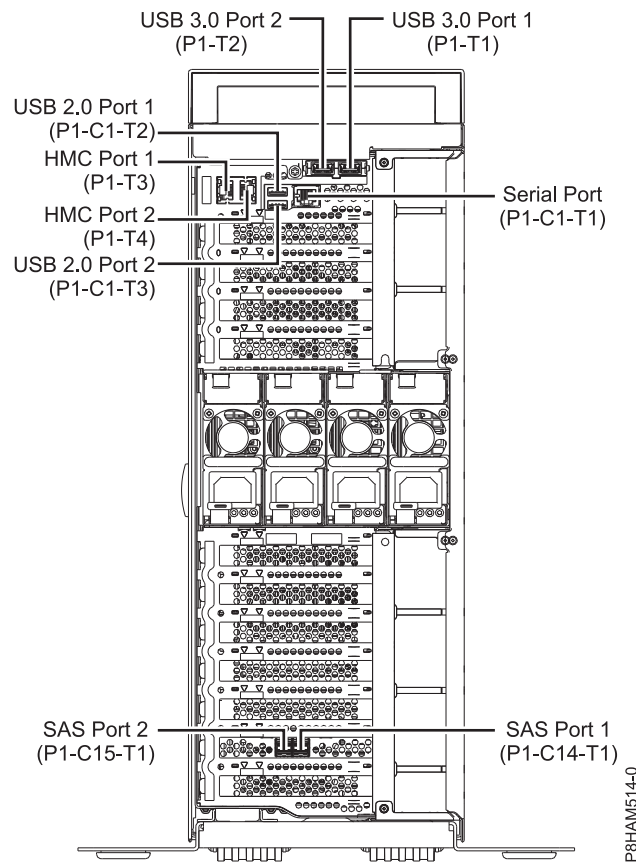

Figure 29. Connector locations for the stand-alone 8286-41A (expanded function) system

## Connector locations for the 8247-42L and 8286-42A systems

Learn about connector locations for the 8247-42L and 8286-42A rack-mounted models.

The 8247-42L and 8286-42A (expanded function) servers provide cable connector locations via a SAS port for disk drive enclosures.



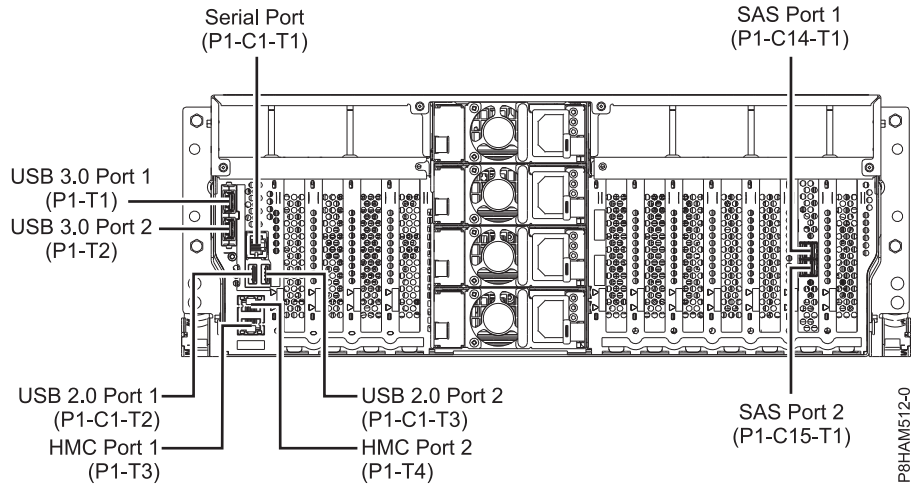

Figure 30. Connector locations for the 8247-42L and 8286-42A (expanded function) systems

## Connector locations for the 8408-44E and 8408-E8E systems

Learn about connector locations for the 8408-44E and 8408-E8E systems.

The 8408-44E and 8408-E8E systems provide cable connector locations via a SAS port (P1-C5-T3) for disk drive enclosures and cable ports (P1-C5-T1 and P1-C5-T2) for the EMX0 PCIe3 expansion drawer.

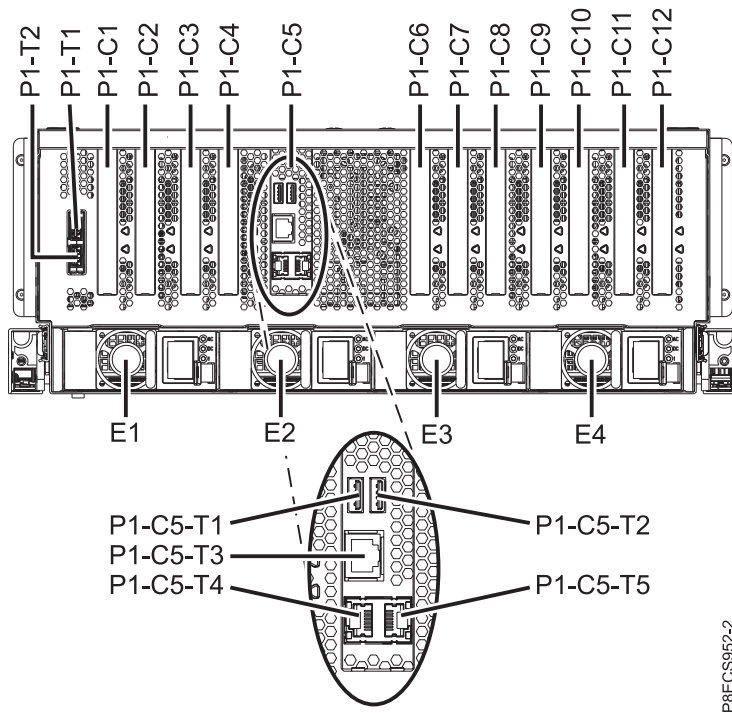

Figure 31. Connector locations for the 8408-44E and 8408-E8E systems

## Connector locations for the 9080-MHE, 9080-MME, 9119-MHE, and 9119-MME systems

Learn about connector locations for the 9080-MHE, 9080-MME, 9119-MHE, and 9119-MME systems.

The 9080-MHE, 9080-MME, 9119-MHE, and 9119-MME servers provide cable connector locations for the EMX0 PCIe Gen3 I/O expansion drawer.

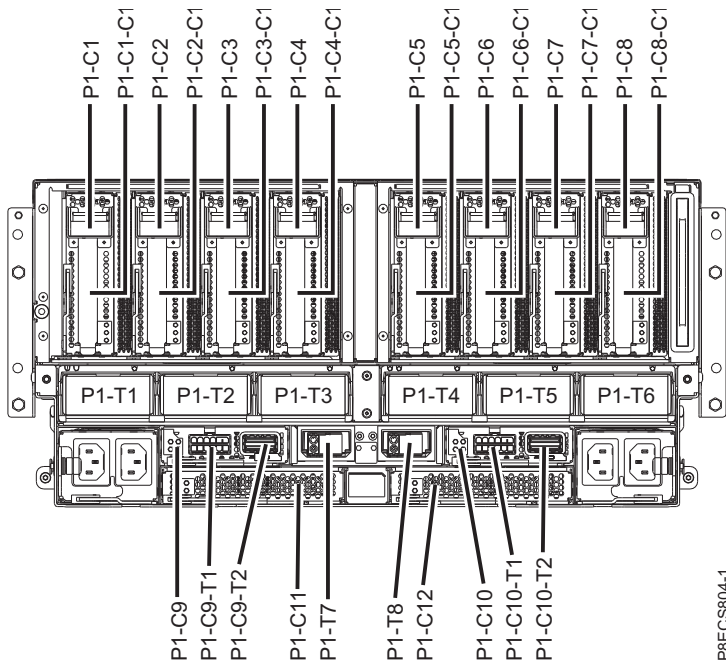

Figure 32. Connector locations for the 9080-MHE, 9080-MME, 9119-MHE, and 9119-MME systems

---

## Notices

This information was developed for products and services offered in the US.

IBM may not offer the products, services, or features discussed in this document in other countries. Consult your local IBM representative for information on the products and services currently available in your area. Any reference to an IBM product, program, or service is not intended to state or imply that only that IBM product, program, or service may be used. Any functionally equivalent product, program, or service that does not infringe any IBM intellectual property right may be used instead. However, it is the user's responsibility to evaluate and verify the operation of any non-IBM product, program, or service.

IBM may have patents or pending patent applications covering subject matter described in this document. The furnishing of this document does not grant you any license to these patents. You can send license inquiries, in writing, to:

*IBM Director of Licensing  
IBM Corporation  
North Castle Drive, MD-NC119  
Armonk, NY 10504-1785  
US*

INTERNATIONAL BUSINESS MACHINES CORPORATION PROVIDES THIS PUBLICATION "AS IS" WITHOUT WARRANTY OF ANY KIND, EITHER EXPRESS OR IMPLIED, INCLUDING, BUT NOT LIMITED TO, THE IMPLIED WARRANTIES OF NON-INFRINGEMENT, MERCHANTABILITY OR FITNESS FOR A PARTICULAR PURPOSE. Some jurisdictions do not allow disclaimer of express or implied warranties in certain transactions, therefore, this statement may not apply to you.

This information could include technical inaccuracies or typographical errors. Changes are periodically made to the information herein; these changes will be incorporated in new editions of the publication. IBM may make improvements and/or changes in the product(s) and/or the program(s) described in this publication at any time without notice.

Any references in this information to non-IBM websites are provided for convenience only and do not in any manner serve as an endorsement of those websites. The materials at those websites are not part of the materials for this IBM product and use of those websites is at your own risk.

IBM may use or distribute any of the information you provide in any way it believes appropriate without incurring any obligation to you.

The performance data and client examples cited are presented for illustrative purposes only. Actual performance results may vary depending on specific configurations and operating conditions.

Information concerning non-IBM products was obtained from the suppliers of those products, their published announcements or other publicly available sources. IBM has not tested those products and cannot confirm the accuracy of performance, compatibility or any other claims related to non-IBM products. Questions on the capabilities of non-IBM products should be addressed to the suppliers of those products.

Statements regarding IBM's future direction or intent are subject to change or withdrawal without notice, and represent goals and objectives only.

All IBM prices shown are IBM's suggested retail prices, are current and are subject to change without notice. Dealer prices may vary.

This information is for planning purposes only. The information herein is subject to change before the products described become available.

This information contains examples of data and reports used in daily business operations. To illustrate them as completely as possible, the examples include the names of individuals, companies, brands, and products. All of these names are fictitious and any similarity to actual people or business enterprises is entirely coincidental.

If you are viewing this information in softcopy, the photographs and color illustrations may not appear.

The drawings and specifications contained herein shall not be reproduced in whole or in part without the written permission of IBM.

IBM has prepared this information for use with the specific machines indicated. IBM makes no representations that it is suitable for any other purpose.

IBM's computer systems contain mechanisms designed to reduce the possibility of undetected data corruption or loss. This risk, however, cannot be eliminated. Users who experience unplanned outages, system failures, power fluctuations or outages, or component failures must verify the accuracy of operations performed and data saved or transmitted by the system at or near the time of the outage or failure. In addition, users must establish procedures to ensure that there is independent data verification before relying on such data in sensitive or critical operations. Users should periodically check IBM's support websites for updated information and fixes applicable to the system and related software.

## Homologation statement

This product may not be certified in your country for connection by any means whatsoever to interfaces of public telecommunications networks. Further certification may be required by law prior to making any such connection. Contact an IBM representative or reseller for any questions.

---

## Accessibility features for IBM Power Systems servers

Accessibility features assist users who have a disability, such as restricted mobility or limited vision, to use information technology content successfully.

### Overview

The IBM Power Systems servers include the following major accessibility features:

- Keyboard-only operation
- Operations that use a screen reader

The IBM Power Systems servers use the latest W3C Standard, WAI-ARIA 1.0 ([www.w3.org/TR/wai-aria/](http://www.w3.org/TR/wai-aria/)), to ensure compliance with US Section 508 ([www.access-board.gov/guidelines-and-standards/communications-and-it/about-the-section-508-standards/section-508-standards](http://www.access-board.gov/guidelines-and-standards/communications-and-it/about-the-section-508-standards/section-508-standards)) and Web Content Accessibility Guidelines (WCAG) 2.0 ([www.w3.org/TR/WCAG20/](http://www.w3.org/TR/WCAG20/)). To take advantage of accessibility features, use the latest release of your screen reader and the latest web browser that is supported by the IBM Power Systems servers.

The IBM Power Systems servers online product documentation in IBM Knowledge Center is enabled for accessibility. The accessibility features of IBM Knowledge Center are described in the Accessibility section of the IBM Knowledge Center help ([www.ibm.com/support/knowledgcenter/doc/kc\\_help.html#accessibility](http://www.ibm.com/support/knowledgcenter/doc/kc_help.html#accessibility)).

## Keyboard navigation

This product uses standard navigation keys.

## Interface information

The IBM Power Systems servers user interfaces do not have content that flashes 2 - 55 times per second.

The IBM Power Systems servers web user interface relies on cascading style sheets to render content properly and to provide a usable experience. The application provides an equivalent way for low-vision users to use system display settings, including high-contrast mode. You can control font size by using the device or web browser settings.

The IBM Power Systems servers web user interface includes WAI-ARIA navigational landmarks that you can use to quickly navigate to functional areas in the application.

## Vendor software

The IBM Power Systems servers include certain vendor software that is not covered under the IBM license agreement. IBM makes no representation about the accessibility features of these products. Contact the vendor for accessibility information about its products.

## Related accessibility information

In addition to standard IBM help desk and support websites, IBM has a TTY telephone service for use by deaf or hard of hearing customers to access sales and support services:

TTY service  
800-IBM-3383 (800-426-3383)  
(within North America)

For more information about the commitment that IBM has to accessibility, see IBM Accessibility ([www.ibm.com/able](http://www.ibm.com/able)).

---

## Privacy policy considerations

IBM Software products, including software as a service solutions, (“Software Offerings”) may use cookies or other technologies to collect product usage information, to help improve the end user experience, to tailor interactions with the end user, or for other purposes. In many cases no personally identifiable information is collected by the Software Offerings. Some of our Software Offerings can help enable you to collect personally identifiable information. If this Software Offering uses cookies to collect personally identifiable information, specific information about this offering’s use of cookies is set forth below.

This Software Offering does not use cookies or other technologies to collect personally identifiable information.

If the configurations deployed for this Software Offering provide you as the customer the ability to collect personally identifiable information from end users via cookies and other technologies, you should seek your own legal advice about any laws applicable to such data collection, including any requirements for notice and consent.

For more information about the use of various technologies, including cookies, for these purposes, see IBM’s Privacy Policy at <http://www.ibm.com/privacy> and IBM’s Online Privacy Statement at <http://www.ibm.com/privacy/details> the section entitled “Cookies, Web Beacons and Other Technologies” and the “IBM Software Products and Software-as-a-Service Privacy Statement” at <http://www.ibm.com/software/info/product-privacy>.

---

## Trademarks

IBM, the IBM logo, and ibm.com are trademarks or registered trademarks of International Business Machines Corp., registered in many jurisdictions worldwide. Other product and service names might be trademarks of IBM or other companies. A current list of IBM trademarks is available on the web at Copyright and trademark information at [www.ibm.com/legal/copytrade.shtml](http://www.ibm.com/legal/copytrade.shtml).

Linux is a registered trademark of Linus Torvalds in the United States, other countries, or both.

---

## Electronic emission notices

When attaching a monitor to the equipment, you must use the designated monitor cable and any interference suppression devices supplied with the monitor.

## Class A Notices

The following Class A statements apply to the IBM servers that contain the POWER8 processor and its features unless designated as electromagnetic compatibility (EMC) Class B in the feature information.

## Federal Communications Commission (FCC) Statement

**Note:** This equipment has been tested and found to comply with the limits for a Class A digital device, pursuant to Part 15 of the FCC Rules. These limits are designed to provide reasonable protection against harmful interference when the equipment is operated in a commercial environment. This equipment generates, uses, and can radiate radio frequency energy and, if not installed and used in accordance with the instruction manual, may cause harmful interference to radio communications. Operation of this equipment in a residential area is likely to cause harmful interference, in which case the user will be required to correct the interference at his own expense.

Properly shielded and grounded cables and connectors must be used in order to meet FCC emission limits. IBM is not responsible for any radio or television interference caused by using other than recommended cables and connectors or by unauthorized changes or modifications to this equipment. Unauthorized changes or modifications could void the user's authority to operate the equipment.

This device complies with Part 15 of the FCC rules. Operation is subject to the following two conditions: (1) this device may not cause harmful interference, and (2) this device must accept any interference received, including interference that may cause undesired operation.

## Industry Canada Compliance Statement

CAN ICES-3 (A)/NMB-3(A)

## European Community Compliance Statement

This product is in conformity with the protection requirements of EU Council Directive 2014/30/EU on the approximation of the laws of the Member States relating to electromagnetic compatibility. IBM cannot accept responsibility for any failure to satisfy the protection requirements resulting from a non-recommended modification of the product, including the fitting of non-IBM option cards.

European Community contact:

IBM Deutschland GmbH

Technical Regulations, Abteilung M456

IBM-Allee 1, 71139 Ehningen, Germany

Tel: +49 800 225 5426

email: [halloibm@de.ibm.com](mailto:halloibm@de.ibm.com)

**Warning:** This is a Class A product. In a domestic environment, this product may cause radio interference, in which case the user may be required to take adequate measures.

### VCCI Statement - Japan

この装置は、クラスA 情報技術装置です。この装置を家庭環境で使用すると電波妨害を引き起こすことがあります。この場合には使用者が適切な対策を講ずるよう要求されることがあります。 VCCI-A

The following is a summary of the VCCI Japanese statement in the box above:

This is a Class A product based on the standard of the VCCI Council. If this equipment is used in a domestic environment, radio interference may occur, in which case, the user may be required to take corrective actions.

### Japan Electronics and Information Technology Industries Association Statement

This statement explains the Japan JIS C 61000-3-2 product wattage compliance.

(一社) 電子情報技術産業協会 高調波電流抑制対策実施  
要領に基づく定格入力電力値 : Knowledge Centerの各製品の  
仕様ページ参照

This statement explains the Japan Electronics and Information Technology Industries Association (JEITA) statement for products less than or equal to 20 A per phase.

高調波電流規格 JIS C 61000-3-2 適合品

This statement explains the JEITA statement for products greater than 20 A, single phase.

高調波電流規格 JIS C 61000-3-2 準用品

本装置は、「高圧又は特別高圧で受電する需要家の高調波抑制対策ガイドライン」対象機器（高調波発生機器）です。

- 回路分類 : 6 (単相、PFC回路付)
- 換算係数 : 0

This statement explains the JEITA statement for products greater than 20 A per phase, three-phase.

高調波電流規格 JIS C 61000-3-2 準用品

本装置は、「高圧又は特別高圧で受電する需要家の高調波抑制対策ガイドライン」対象機器（高調波発生機器）です。

- 回路分類 : 5 (3相、PFC回路付)
- 換算係数 : 0

**Electromagnetic Interference (EMI) Statement - People's Republic of China**

声 明

此为 A 级产品, 在生活环境中, 该产品可能会造成无线电干扰。在这种情况下, 可能需要用户对其干扰采取切实可行的措施。

Declaration: This is a Class A product. In a domestic environment this product may cause radio interference in which case the user may need to perform practical action.

**Electromagnetic Interference (EMI) Statement - Taiwan**

警告使用者：

這是甲類的資訊產品，在居住的環境中使用時，可能會造成射頻干擾，在這種情況下，使用者會被要求採取某些適當的對策。

The following is a summary of the EMI Taiwan statement above.

Warning: This is a Class A product. In a domestic environment this product may cause radio interference in which case the user will be required to take adequate measures.

**IBM Taiwan Contact Information:**

台灣IBM 產品服務聯絡方式：  
台灣國際商業機器股份有限公司  
台北市松仁路7號3樓  
電話：0800-016-888



## **Electromagnetic Interference (EMI) Statement - Korea**

이 기기는 업무용 환경에서 사용할 목적으로 적합성평가를 받은 기기로서 가정용 환경에서 사용하는 경우 전파간섭의 우려가 있습니다.

## **Germany Compliance Statement**

### **Deutschsprachiger EU Hinweis: Hinweis für Geräte der Klasse A EU-Richtlinie zur Elektromagnetischen Verträglichkeit**

Dieses Produkt entspricht den Schutzanforderungen der EU-Richtlinie 2014/30/EU zur Angleichung der Rechtsvorschriften über die elektromagnetische Verträglichkeit in den EU-Mitgliedsstaaten und hält die Grenzwerte der EN 55022 / EN 55032 Klasse A ein.

Um dieses sicherzustellen, sind die Geräte wie in den Handbüchern beschrieben zu installieren und zu betreiben. Des Weiteren dürfen auch nur von der IBM empfohlene Kabel angeschlossen werden. IBM übernimmt keine Verantwortung für die Einhaltung der Schutzanforderungen, wenn das Produkt ohne Zustimmung von IBM verändert bzw. wenn Erweiterungskomponenten von Fremdherstellern ohne Empfehlung von IBM gesteckt/eingebaut werden.

EN 55022 / EN 55032 Klasse A Geräte müssen mit folgendem Warnhinweis versehen werden:  
"Warnung: Dieses ist eine Einrichtung der Klasse A. Diese Einrichtung kann im Wohnbereich Funk-Störungen verursachen; in diesem Fall kann vom Betreiber verlangt werden, angemessene Maßnahmen zu ergreifen und dafür aufzukommen."

### **Deutschland: Einhaltung des Gesetzes über die elektromagnetische Verträglichkeit von Geräten**

Dieses Produkt entspricht dem "Gesetz über die elektromagnetische Verträglichkeit von Geräten (EMVG)". Dies ist die Umsetzung der EU-Richtlinie 2014/30/EU in der Bundesrepublik Deutschland.

### **Zulassungsbescheinigung laut dem Deutschen Gesetz über die elektromagnetische Verträglichkeit von Geräten (EMVG) (bzw. der EMC Richtlinie 2014/30/EU) für Geräte der Klasse A**

Dieses Gerät ist berechtigt, in Übereinstimmung mit dem Deutschen EMVG das EG-Konformitätszeichen - CE - zu führen.

Verantwortlich für die Einhaltung der EMV Vorschriften ist der Hersteller:  
International Business Machines Corp.  
New Orchard Road  
Armonk, New York 10504  
Tel: 914-499-1900

Der verantwortliche Ansprechpartner des Herstellers in der EU ist:  
IBM Deutschland GmbH  
Technical Relations Europe, Abteilung M456  
IBM-Allee 1, 71139 Ehningen, Germany  
Tel: +49 (0) 800 225 5426  
email: HalloIBM@de.ibm.com

Generelle Informationen:

**Das Gerät erfüllt die Schutzanforderungen nach EN 55024 und EN 55022 / EN 55032 Klasse A.**

## Electromagnetic Interference (EMI) Statement - Russia

**ВНИМАНИЕ!** Настоящее изделие относится к классу А.  
В жилых помещениях оно может создавать  
радиопомехи, для снижения которых необходимы  
дополнительные меры

### Class B Notices

The following Class B statements apply to features designated as electromagnetic compatibility (EMC) Class B in the feature installation information.

### Federal Communications Commission (FCC) Statement

This equipment has been tested and found to comply with the limits for a Class B digital device, pursuant to Part 15 of the FCC Rules. These limits are designed to provide reasonable protection against harmful interference in a residential installation.

This equipment generates, uses, and can radiate radio frequency energy and, if not installed and used in accordance with the instructions, may cause harmful interference to radio communications. However, there is no guarantee that interference will not occur in a particular installation.

If this equipment does cause harmful interference to radio or television reception, which can be determined by turning the equipment off and on, the user is encouraged to try to correct the interference by one or more of the following measures:

- Reorient or relocate the receiving antenna.
- Increase the separation between the equipment and receiver.
- Connect the equipment into an outlet on a circuit different from that to which the receiver is connected.
- Consult an IBM-authorized dealer or service representative for help.

Properly shielded and grounded cables and connectors must be used in order to meet FCC emission limits. Proper cables and connectors are available from IBM-authorized dealers. IBM is not responsible for any radio or television interference caused by unauthorized changes or modifications to this equipment. Unauthorized changes or modifications could void the user's authority to operate this equipment.

This device complies with Part 15 of the FCC rules. Operation is subject to the following two conditions: (1) this device may not cause harmful interference, and (2) this device must accept any interference received, including interference that may cause undesired operation.

### Industry Canada Compliance Statement

CAN ICES-3 (B)/NMB-3(B)

### European Community Compliance Statement

This product is in conformity with the protection requirements of EU Council Directive 2014/30/EU on the approximation of the laws of the Member States relating to electromagnetic compatibility. IBM cannot accept responsibility for any failure to satisfy the protection requirements resulting from a non-recommended modification of the product, including the fitting of non-IBM option cards.

European Community contact:  
IBM Deutschland GmbH  
Technical Regulations, Abteilung M456  
IBM-Allee 1, 71139 Ehningen, Germany  
Tel: +49 800 225 5426  
email: halloibm@de.ibm.com

## VCCI Statement - Japan

この装置は、クラスB情報技術装置です。この装置は、家庭環境で使用することを目的としていますが、この装置がラジオやテレビジョン受信機に近接して使用されると、受信障害を引き起こすことがあります。

取扱説明書に従って正しい取り扱いをして下さい。 VCCI-B

## Japan Electronics and Information Technology Industries Association Statement

This statement explains the Japan JIS C 61000-3-2 product wattage compliance.

(一社) 電子情報技術産業協会 高調波電流抑制対策実施  
要領に基づく定格入力電力値 : Knowledge Centerの各製品の  
仕様ページ参照

This statement explains the Japan Electronics and Information Technology Industries Association (JEITA) statement for products less than or equal to 20 A per phase.

高調波電流規格 JIS C 61000-3-2 適合品

This statement explains the JEITA statement for products greater than 20 A, single phase.

高調波電流規格 JIS C 61000-3-2 準用品

本装置は、「高圧又は特別高圧で受電する需要家の高調波抑制対策ガイドライン」対象機器（高調波発生機器）です。

- 回路分類 : 6 (単相、PFC回路付)
- 換算係数 : 0

This statement explains the JEITA statement for products greater than 20 A per phase, three-phase.

高調波電流規格 JIS C 61000-3-2 準用品

本装置は、「高圧又は特別高圧で受電する需要家の高調波抑制対策ガイドライン」対象機器（高調波発生機器）です。

- 回路分類 : 5 (3相、PFC回路付)
- 換算係数 : 0

### IBM Taiwan Contact Information

台灣IBM 產品服務聯絡方式：  
台灣國際商業機器股份有限公司  
台北市松仁路7號3樓  
電話：0800-016-888

### Germany Compliance Statement

**Deutschsprachiger EU Hinweis: Hinweis für Geräte der Klasse B EU-Richtlinie zur Elektromagnetischen Verträglichkeit**

Dieses Produkt entspricht den Schutzanforderungen der EU-Richtlinie 2014/30/EU zur Angleichung der Rechtsvorschriften über die elektromagnetische Verträglichkeit in den EU-Mitgliedsstaaten und hält die Grenzwerte der EN 55022/ EN 55032 Klasse B ein.

Um dieses sicherzustellen, sind die Geräte wie in den Handbüchern beschrieben zu installieren und zu betreiben. Des Weiteren dürfen auch nur von der IBM empfohlene Kabel angeschlossen werden. IBM übernimmt keine Verantwortung für die Einhaltung der Schutzanforderungen, wenn das Produkt ohne Zustimmung von IBM verändert bzw. wenn Erweiterungskomponenten von Fremdherstellern ohne Empfehlung von IBM gesteckt/eingebaut werden.

**Deutschland: Einhaltung des Gesetzes über die elektromagnetische Verträglichkeit von Geräten**

Dieses Produkt entspricht dem "Gesetz über die elektromagnetische Verträglichkeit von Geräten (EMVG)". Dies ist die Umsetzung der EU-Richtlinie 2014/30/EU in der Bundesrepublik Deutschland.

**Zulassungsbescheinigung laut dem Deutschen Gesetz über die elektromagnetische Verträglichkeit von Geräten (EMVG) (bzw. der EMC Richtlinie 2014/30/EU) für Geräte der Klasse B**

Dieses Gerät ist berechtigt, in Übereinstimmung mit dem Deutschen EMVG das EG-Konformitätszeichen - CE - zu führen.

Verantwortlich für die Einhaltung der EMV Vorschriften ist der Hersteller:  
International Business Machines Corp.  
New Orchard Road  
Armonk, New York 10504

Tel: 914-499-1900

Der verantwortliche Ansprechpartner des Herstellers in der EU ist:

IBM Deutschland GmbH  
Technical Relations Europe, Abteilung M456  
IBM-Allee 1, 71139 Ehningen, Germany  
Tel: +49 (0) 800 225 5426  
email: HalloIBM@de.ibm.com

Generelle Informationen:

**Das Gerät erfüllt die Schutzanforderungen nach EN 55024 und EN 55022/ EN 55032 Klasse B.**

---

## Terms and conditions

Permissions for the use of these publications are granted subject to the following terms and conditions.

**Applicability:** These terms and conditions are in addition to any terms of use for the IBM website.

**Personal Use:** You may reproduce these publications for your personal, noncommercial use provided that all proprietary notices are preserved. You may not distribute, display or make derivative works of these publications, or any portion thereof, without the express consent of IBM.

**Commercial Use:** You may reproduce, distribute and display these publications solely within your enterprise provided that all proprietary notices are preserved. You may not make derivative works of these publications, or reproduce, distribute or display these publications or any portion thereof outside your enterprise, without the express consent of IBM.

**Rights:** Except as expressly granted in this permission, no other permissions, licenses or rights are granted, either express or implied, to the publications or any information, data, software or other intellectual property contained therein.

IBM reserves the right to withdraw the permissions granted herein whenever, in its discretion, the use of the publications is detrimental to its interest or, as determined by IBM, the above instructions are not being properly followed.

You may not download, export or re-export this information except in full compliance with all applicable laws and regulations, including all United States export laws and regulations.

IBM MAKES NO GUARANTEE ABOUT THE CONTENT OF THESE PUBLICATIONS. THE PUBLICATIONS ARE PROVIDED "AS-IS" AND WITHOUT WARRANTY OF ANY KIND, EITHER EXPRESSED OR IMPLIED, INCLUDING BUT NOT LIMITED TO IMPLIED WARRANTIES OF MERCHANTABILITY, NON-INFRINGEMENT, AND FITNESS FOR A PARTICULAR PURPOSE.







Part Number: 01LK529

Printed in USA

GI11-9921-01



(1P) P/N: 01LK529

