

Power Systems

*Installing the System and Ordered
Parts for the IBM Power System
S822LC (8335-GCA and 8335-GTA)*

IBM

Power Systems

*Installing the System and Ordered
Parts for the IBM Power System
S822LC (8335-GCA and 8335-GTA)*

IBM

Note

Before using this information and the product it supports, read the information in “Safety notices” on page v, “Notices” on page 111, the *IBM Systems Safety Notices* manual, G229-9054, and the *IBM Environmental Notices and User Guide*, Z125-5823.

This edition applies to IBM Power Systems™ servers that contain the POWER8® processor and to all associated models.

© Copyright IBM Corporation 2015, 2017.

US Government Users Restricted Rights – Use, duplication or disclosure restricted by GSA ADP Schedule Contract with IBM Corp.

Contents

Safety notices	v
---------------------------------	----------

Installing the IBM Power System S822LC (8335-GTA and 8335-GCA) **1**

Prerequisite for installing the rack-mounted server	1
Completing inventory for your server	1
Determining and marking the location in the rack	2
Installing the system using the slide rails	3
Attaching the slide rails to the rack	4
Installing the system into the rack by using the slide rails	6
Installing the cable-management arm and connecting and routing power cables	7
Installing the system using the fixed rails	13
Attaching the fixed rails to the rack	13
Installing the system into the rack by using the fixed rails and connecting power cables	14
Completing server setup	16

Installing and configuring system features **17**

Installing a disk drive in the 8335-GCA or 8335-GTA	17
Installing a disk drive in the 8335-GCA or 8335-GTA system with the power turned off	17
Installing a disk drive in the 8335-GCA or 8335-GTA system with the power turned off	17
Installing a disk drive in the 8335-GCA or 8335-GTA system with the power turned on	19
Installing a disk drive in the 8335-GCA or 8335-GTA system with the power turned on	19
Installing the graphics processing unit in the 8335-GCA or 8335-GTA system	20
Installing memory in the 8335-GCA	22
Plugging rules for memory in the 8335-GCA system	25
Installing PCIe adapters in the 8335-GCA or 8335-GTA	26
PCIe adapter placement rules and slot priorities for the 8335-GCA or 8335-GTA	27
Installing a PCIe adapter in the system backplane of a 8335-GCA or 8335-GTA system	32
Installing a PCIe adapter in a PCIe riser in the 8335-GCA or 8335-GTA system	34
PCIe adapters	37
PCIe2 LP 4-port 1GbE Adapter (FC 5260; CCIN 576F)	37
PCIe2 4-port 1 GbE Adapter (FC 5899; CCIN 576F)	40
PCIe3 LP 2-Port 40 GbE NIC RoCE QSFP+ Adapter (FC EC3A; CCIN 57BD)	43
PCIe3 2-Port 40 GbE NIC RoCE QSFP+ Adapter (FC EC3B; CCIN 57BD)	46
PCIe3 LP 2-port 100 Gb EDR InfiniBand Adapter (FC EC3E and EC3F; CCIN 2CEA)	50

PCIe3 LP 1-port 100 Gb EDR InfiniBand adapter x16 (FC EC3T and EC3U; CCIN 2CEB)	51
PCIe Gen3 x16 GPU Adapter (FC EC49; CCIN 2CE9)	53
CAPI Compression Accelerator Adapter (FC EJ1A and EJ1B; CCIN 2CF0)	54
PCIe3 FPGA Compression Accelerator Adapter (FC EJ12; CCIN 59AB)	57
PCIe3 FPGA Compression Accelerator Adapter (FC EJ13; CCIN 59AB)	59
PCIe2 LP 2-port 10 GbE BaseT RJ45 Adapter (FC EL3Z; CCIN 2CC4)	62
PCIe3 LP 16 Gb 2-port Fibre Channel Adapter (FC EL43; CCIN 577F)	64
PCIe2 4-port 1 GbE Adapter (FC EL4L and EL4M; CCIN 576F)	68
PCIe2 4-port 1 GbE Adapter (FC EL4L and EL4M; CCIN 576F)	71
PCIe2 2-port 10 GbE BaseT RJ45 Adapter (FC EL55; CCIN 2CC4)	74
PCIe2 16 Gb 2-port Fibre Channel Adapter (FC EL5B; CCIN 577F)	76
PCIe3 4-Port (10 Gb + 1 GbE) SR+RJ45 Adapter (FC EN0S; CCIN 2CC3)	80
PCIe3 LP 4-Port (10Gb+1GbE) SR+RJ45 Adapter (FC EN0T; CCIN 2CC3)	84

Common procedures for servicing or installing features in the 8335-GCA or 8335-GTA. **89**

Before you begin	89
Identifying the system that contains the part to replace	92
LEDs on the 8335-GCA or 8335-GTA system	92
Identifying the 8335-GCA or 8335-GTA that needs servicing	93
Starting and stopping the 8335-GCA or 8335-GTA	93
Starting the system	93
Stopping the system	94
Event sensor status GUI display	94
Removing and replacing covers on an 8335-GCA or 8335-GTA system	97
Removing the service access cover from an 8335-GCA or 8335-GTA system	97
Installing the service access cover on an 8335-GCA or 8335-GTA system	97
Service and operating positions for 8335-GCA or 8335-GTA	98
Placing an 8335-GCA or 8335-GTA system into the service position	98
Slide rails	99
Fixed rails	99
Placing an 8335-GCA or 8335-GTA system into the operating position	100

Slide rails	100
Fixed rails	101
Power cords	101
Disconnecting the power cords from an 8335-GCA or 8335-GTA system	102
Connecting the power cords to an 8335-GCA or 8335-GTA system	104

Removing and replacing a power supply in the 8335-GCA or 8335-GTA . 107

Removing a power supply from the 8335-GCA or 8335-GTA.	107
---	-----

Replacing a power supply in the 8335-GCA or 8335-GTA.	108
--	-----

Notices 111

Accessibility features for IBM Power Systems servers	112
Privacy policy considerations	113
Trademarks	114
Electronic emission notices	114
Class A Notices	114
Class B Notices	118
Terms and conditions.	121

Safety notices

Safety notices may be printed throughout this guide:

- **DANGER** notices call attention to a situation that is potentially lethal or extremely hazardous to people.
- **CAUTION** notices call attention to a situation that is potentially hazardous to people because of some existing condition.
- **Attention** notices call attention to the possibility of damage to a program, device, system, or data.

World Trade safety information

Several countries require the safety information contained in product publications to be presented in their national languages. If this requirement applies to your country, safety information documentation is included in the publications package (such as in printed documentation, on DVD, or as part of the product) shipped with the product. The documentation contains the safety information in your national language with references to the U.S. English source. Before using a U.S. English publication to install, operate, or service this product, you must first become familiar with the related safety information documentation. You should also refer to the safety information documentation any time you do not clearly understand any safety information in the U.S. English publications.

Replacement or additional copies of safety information documentation can be obtained by calling the IBM Hotline at 1-800-300-8751.

German safety information

Das Produkt ist nicht für den Einsatz an Bildschirmarbeitsplätzen im Sinne § 2 der Bildschirmarbeitsverordnung geeignet.

Laser safety information

IBM® servers can use I/O cards or features that are fiber-optic based and that utilize lasers or LEDs.

Laser compliance

IBM servers may be installed inside or outside of an IT equipment rack.

DANGER: When working on or around the system, observe the following precautions:

Electrical voltage and current from power, telephone, and communication cables are hazardous. To avoid a shock hazard:

- If IBM supplied the power cord(s), connect power to this unit only with the IBM provided power cord. Do not use the IBM provided power cord for any other product.
- Do not open or service any power supply assembly.
- Do not connect or disconnect any cables or perform installation, maintenance, or reconfiguration of this product during an electrical storm.
- The product might be equipped with multiple power cords. To remove all hazardous voltages, disconnect all power cords.
 - For AC power, disconnect all power cords from their AC power source.
 - For racks with a DC power distribution panel (PDP), disconnect the customer's DC power source to the PDP.
- When connecting power to the product ensure all power cables are properly connected.

- For racks with AC power, connect all power cords to a properly wired and grounded electrical outlet. Ensure that the outlet supplies proper voltage and phase rotation according to the system rating plate.
- For racks with a DC power distribution panel (PDP), connect the customer's DC power source to the PDP. Ensure that the proper polarity is used when attaching the DC power and DC power return wiring.
- Connect any equipment that will be attached to this product to properly wired outlets.
- When possible, use one hand only to connect or disconnect signal cables.
- Never turn on any equipment when there is evidence of fire, water, or structural damage.
- Do not attempt to switch on power to the machine until all possible unsafe conditions are corrected.
- Assume that an electrical safety hazard is present. Perform all continuity, grounding, and power checks specified during the subsystem installation procedures to ensure that the machine meets safety requirements.
- Do not continue with the inspection if any unsafe conditions are present.
- Before you open the device covers, unless instructed otherwise in the installation and configuration procedures: Disconnect the attached AC power cords, turn off the applicable circuit breakers located in the rack power distribution panel (PDP), and disconnect any telecommunications systems, networks, and modems.

DANGER:

- Connect and disconnect cables as described in the following procedures when installing, moving, or opening covers on this product or attached devices.

To Disconnect:

1. Turn off everything (unless instructed otherwise).
2. For AC power, remove the power cords from the outlets.
3. For racks with a DC power distribution panel (PDP), turn off the circuit breakers located in the PDP and remove the power from the Customer's DC power source.
4. Remove the signal cables from the connectors.
5. Remove all cables from the devices.

To Connect:

1. Turn off everything (unless instructed otherwise).
2. Attach all cables to the devices.
3. Attach the signal cables to the connectors.
4. For AC power, attach the power cords to the outlets.
5. For racks with a DC power distribution panel (PDP), restore the power from the Customer's DC power source and turn on the circuit breakers located in the PDP.
6. Turn on the devices.

Sharp edges, corners and joints may be present in and around the system. Use care when handling equipment to avoid cuts, scrapes and pinching. (D005)

(R001 part 1 of 2):

DANGER: Observe the following precautions when working on or around your IT rack system:

- Heavy equipment—personal injury or equipment damage might result if mishandled.
- Always lower the leveling pads on the rack cabinet.
- Always install stabilizer brackets on the rack cabinet.
- To avoid hazardous conditions due to uneven mechanical loading, always install the heaviest devices in the bottom of the rack cabinet. Always install servers and optional devices starting from the bottom of the rack cabinet.
- Rack-mounted devices are not to be used as shelves or work spaces. Do not place objects on top of rack-mounted devices. In addition, do not lean on rack mounted devices and do not use them to stabilize your body position (for example, when working from a ladder).



- Each rack cabinet might have more than one power cord.
 - For AC powered racks, be sure to disconnect all power cords in the rack cabinet when directed to disconnect power during servicing.
 - For racks with a DC power distribution panel (PDP), turn off the circuit breaker that controls the power to the system unit(s), or disconnect the customer's DC power source, when directed to disconnect power during servicing.
- Connect all devices installed in a rack cabinet to power devices installed in the same rack cabinet. Do not plug a power cord from a device installed in one rack cabinet into a power device installed in a different rack cabinet.
- An electrical outlet that is not correctly wired could place hazardous voltage on the metal parts of the system or the devices that attach to the system. It is the responsibility of the customer to ensure that the outlet is correctly wired and grounded to prevent an electrical shock.

(R001 part 2 of 2):

CAUTION:

- Do not install a unit in a rack where the internal rack ambient temperatures will exceed the manufacturer's recommended ambient temperature for all your rack-mounted devices.
- Do not install a unit in a rack where the air flow is compromised. Ensure that air flow is not blocked or reduced on any side, front, or back of a unit used for air flow through the unit.
- Consideration should be given to the connection of the equipment to the supply circuit so that overloading of the circuits does not compromise the supply wiring or overcurrent protection. To provide the correct power connection to a rack, refer to the rating labels located on the equipment in the rack to determine the total power requirement of the supply circuit.
- *(For sliding drawers.)* Do not pull out or install any drawer or feature if the rack stabilizer brackets are not attached to the rack. Do not pull out more than one drawer at a time. The rack might become unstable if you pull out more than one drawer at a time.



- *(For fixed drawers.)* This drawer is a fixed drawer and must not be moved for servicing unless specified by the manufacturer. Attempting to move the drawer partially or completely out of the rack might cause the rack to become unstable or cause the drawer to fall out of the rack.

CAUTION:

Removing components from the upper positions in the rack cabinet improves rack stability during relocation. Follow these general guidelines whenever you relocate a populated rack cabinet within a room or building.

- Reduce the weight of the rack cabinet by removing equipment starting at the top of the rack cabinet. When possible, restore the rack cabinet to the configuration of the rack cabinet as you received it. If this configuration is not known, you must observe the following precautions:
 - Remove all devices in the 32U position (compliance ID RACK-001 or 22U (compliance ID RR001) and above.
 - Ensure that the heaviest devices are installed in the bottom of the rack cabinet.
 - Ensure that there are little-to-no empty U-levels between devices installed in the rack cabinet below the 32U (compliance ID RACK-001 or 22U (compliance ID RR001) level, unless the received configuration specifically allowed it.
- If the rack cabinet you are relocating is part of a suite of rack cabinets, detach the rack cabinet from the suite.
- If the rack cabinet you are relocating was supplied with removable outriggers they must be reinstalled before the cabinet is relocated.
- Inspect the route that you plan to take to eliminate potential hazards.
- Verify that the route that you choose can support the weight of the loaded rack cabinet. Refer to the documentation that comes with your rack cabinet for the weight of a loaded rack cabinet.
- Verify that all door openings are at least 760 x 230 mm (30 x 80 in.).
- Ensure that all devices, shelves, drawers, doors, and cables are secure.
- Ensure that the four leveling pads are raised to their highest position.
- Ensure that there is no stabilizer bracket installed on the rack cabinet during movement.
- Do not use a ramp inclined at more than 10 degrees.
- When the rack cabinet is in the new location, complete the following steps:
 - Lower the four leveling pads.
 - Install stabilizer brackets on the rack cabinet.
 - If you removed any devices from the rack cabinet, repopulate the rack cabinet from the lowest position to the highest position.
- If a long-distance relocation is required, restore the rack cabinet to the configuration of the rack cabinet as you received it. Pack the rack cabinet in the original packaging material, or equivalent. Also lower the leveling pads to raise the casters off of the pallet and bolt the rack cabinet to the pallet.

(R002)

(L001)



DANGER: Hazardous voltage, current, or energy levels are present inside any component that has this label attached. Do not open any cover or barrier that contains this label. (L001)

(L002)



DANGER: Rack-mounted devices are not to be used as shelves or work spaces. (L002)

(L003)



or



or



or



or



DANGER: Multiple power cords. The product might be equipped with multiple AC power cords or multiple DC power cables. To remove all hazardous voltages, disconnect all power cords and power cables. (L003)

(L007)



CAUTION: A hot surface nearby. (L007)

(L008)



CAUTION: Hazardous moving parts nearby. (L008)

All lasers are certified in the U.S. to conform to the requirements of DHHS 21 CFR Subchapter J for class 1 laser products. Outside the U.S., they are certified to be in compliance with IEC 60825 as a class 1 laser product. Consult the label on each part for laser certification numbers and approval information.

CAUTION:

This product might contain one or more of the following devices: CD-ROM drive, DVD-ROM drive, DVD-RAM drive, or laser module, which are Class 1 laser products. Note the following information:

- **Do not remove the covers. Removing the covers of the laser product could result in exposure to hazardous laser radiation. There are no serviceable parts inside the device.**
- **Use of the controls or adjustments or performance of procedures other than those specified herein might result in hazardous radiation exposure.**

(C026)

CAUTION:

Data processing environments can contain equipment transmitting on system links with laser modules that operate at greater than Class 1 power levels. For this reason, never look into the end of an optical fiber cable or open receptacle. Although shining light into one end and looking into the other end of a disconnected optical fiber to verify the continuity of optic fibers many not injure the eye, this procedure is potentially dangerous. Therefore, verifying the continuity of optical fibers by shining light into one end and looking at the other end is not recommended. To verify continuity of a fiber optic cable, use an optical light source and power meter. (C027)

CAUTION:

This product contains a Class 1M laser. Do not view directly with optical instruments. (C028)

CAUTION:

Some laser products contain an embedded Class 3A or Class 3B laser diode. Note the following information: laser radiation when open. Do not stare into the beam, do not view directly with optical instruments, and avoid direct exposure to the beam. (C030)

CAUTION:

The battery contains lithium. To avoid possible explosion, do not burn or charge the battery.

Do Not:

- **Throw or immerse into water**
- **Heat to more than 100°C (212°F)**
- **Repair or disassemble**

Exchange only with the IBM-approved part. Recycle or discard the battery as instructed by local regulations. In the United States, IBM has a process for the collection of this battery. For information, call 1-800-426-4333. Have the IBM part number for the battery unit available when you call. (C003)

CAUTION:

Regarding IBM provided VENDOR LIFT TOOL:

- Operation of LIFT TOOL by authorized personnel only.
- LIFT TOOL intended for use to assist, lift, install, remove units (load) up into rack elevations. It is not to be used loaded transporting over major ramps nor as a replacement for such designated tools like pallet jacks, walkies, fork trucks and such related relocation practices. When this is not practicable, specially trained persons or services must be used (for instance, riggers or movers).
- Read and completely understand the contents of LIFT TOOL operator's manual before using. Failure to read, understand, obey safety rules, and follow instructions may result in property damage and/or personal injury. If there are questions, contact the vendor's service and support. Local paper manual must remain with machine in provided storage sleeve area. Latest revision manual available on vendor's web site.
- Test verify stabilizer brake function before each use. Do not over-force moving or rolling the LIFT TOOL with stabilizer brake engaged.
- Do not move LIFT TOOL while platform is raised, except for minor positioning.
- Do not exceed rated load capacity. See LOAD CAPACITY CHART regarding maximum loads at center versus edge of extended platform.
- Only raise load if properly centered on platform. Do not place more than 200 lb (91 kg) on edge of sliding platform shelf also considering the load's center of mass/gravity (CoG).
- Do not corner load the platform tilt riser accessory option. Secure platform riser tilt option to main shelf in all four (4x) locations with provided hardware only, prior to use. Load objects are designed to slide on/off smooth platforms without appreciable force, so take care not to push or lean. Keep riser tilt option flat at all times except for final minor adjustment when needed.
- Do not stand under overhanging load.
- Do not use on uneven surface, incline or decline (major ramps).
- Do not stack loads.
- Do not operate while under the influence of drugs or alcohol.
- Do not support ladder against LIFT TOOL.
- Tipping hazard. Do not push or lean against load with raised platform.
- Do not use as a personnel lifting platform or step. No riders.
- Do not stand on any part of lift. Not a step.
- Do not climb on mast.
- Do not operate a damaged or malfunctioning LIFT TOOL machine.
- Crush and pinch point hazard below platform. Only lower load in areas clear of personnel and obstructions. Keep hands and feet clear during operation.
- No Forks. Never lift or move bare LIFT TOOL MACHINE with pallet truck, jack or fork lift.
- Mast extends higher than platform. Be aware of ceiling height, cable trays, sprinklers, lights, and other overhead objects.
- Do not leave LIFT TOOL machine unattended with an elevated load.
- Watch and keep hands, fingers, and clothing clear when equipment is in motion.
- Turn Winch with hand power only. If winch handle cannot be cranked easily with one hand, it is probably over-loaded. Do not continue to turn winch past top or bottom of platform travel. Excessive unwinding will detach handle and damage cable. Always hold handle when lowering, unwinding. Always assure self that winch is holding load before releasing winch handle.
- A winch accident could cause serious injury. Not for moving humans. Make certain clicking sound is heard as the equipment is being raised. Be sure winch is locked in position before releasing handle. Read instruction page before operating this winch. Never allow winch to unwind freely. Freewheeling will cause uneven cable wrapping around winch drum, damage cable, and may cause serious injury. (C048)

Power and cabling information for NEBS (Network Equipment-Building System) GR-1089-CORE

The following comments apply to the IBM servers that have been designated as conforming to NEBS (Network Equipment-Building System) GR-1089-CORE:

The equipment is suitable for installation in the following:

- Network telecommunications facilities
- Locations where the NEC (National Electrical Code) applies

The intrabuilding ports of this equipment are suitable for connection to intrabuilding or unexposed wiring or cabling only. The intrabuilding ports of this equipment *must not* be metalically connected to the interfaces that connect to the OSP (outside plant) or its wiring. These interfaces are designed for use as intrabuilding interfaces only (Type 2 or Type 4 ports as described in GR-1089-CORE) and require isolation from the exposed OSP cabling. The addition of primary protectors is not sufficient protection to connect these interfaces metalically to OSP wiring.

Note: All Ethernet cables must be shielded and grounded at both ends.

The ac-powered system does not require the use of an external surge protection device (SPD).

The dc-powered system employs an isolated DC return (DC-I) design. The DC battery return terminal *shall not* be connected to the chassis or frame ground.

The dc-powered system is intended to be installed in a common bonding network (CBN) as described in GR-1089-CORE.

Installing the IBM Power System S822LC (8335-GTA and 8335-GCA)

Learn how to install, cable, and set up your server.

Prerequisite for installing the rack-mounted server

Use the information to understand the prerequisites that are required for installing the server.

About this task

You might need to read the following documents before you install the server:

- The latest version of this document is maintained online, see *Installing the IBM Power System S822LC (8335-GTA and 8335-GCA)* (http://www.ibm.com/support/knowledgecenter/HW4M4/p8ehm/p8ehm_kickoff.htm).
- To plan your server installation, see *Planning for the system* (http://www.ibm.com/support/knowledgecenter/POWER8/p8had/p8had_8xx_kickoff.htm).

Procedure

Ensure that you have the following items before starting your installation:

- Phillips screwdriver
- Flat-head screwdriver
- Box cutter
- Electrostatic discharge (ESD) wrist strap
- Rack with two Electronic Industries Association (EIA) units (2U) of space

Note: If you do not have a rack that is installed, install the rack. For instructions, see *Racks and rack features* (http://www.ibm.com/support/knowledgecenter/POWER8/p8hbf/p8hbf_8xx_kickoff.htm).

Completing inventory for your server

Use this information to complete inventory for your server.

Procedure

1. Verify that you received all the boxes you ordered.
2. Unpack the server components as needed.
3. Complete a parts inventory before you install each server component by following these steps:
 - a. Locate the inventory list for your server.
 - b. Ensure that you received all the parts that you ordered.

Note: Your order information is included with your product. You can also obtain order information from your marketing representative or the IBM Business Partner.

If you have incorrect, missing, or damaged parts, consult any of the following resources:

- Your IBM reseller.
- IBM Rochester manufacturing automated information line at 1-800-300-8751 (United States only).
- The Directory of worldwide contacts website <http://www.ibm.com/planetwide>. Select your location to view the service and support contact information.

Determining and marking the location in the rack

You might need to determine where to install the system unit into the rack.

Procedure

1. Read the Rack safety notices (<http://www.ibm.com/support/knowledgecenter/POWER8/p8hbf/racksafety.htm>).
2. Determine where to place the system unit in the rack. As you plan for installing the system unit in a rack, consider the following information:
 - Organize larger and heavier units into the lower part of the rack.
 - Plan to install units into the lower part of the rack first.
 - Record the Electronic Industries Alliance (EIA) locations in your plan.

Note: The server is two EIA units high. An EIA unit is 44.55 mm (1.75 in.) in height. The rack contains three mounting holes for each EIA unit of height. This system unit, therefore, is 89 mm (3.5 in.) high and covers six mounting holes in the rack.

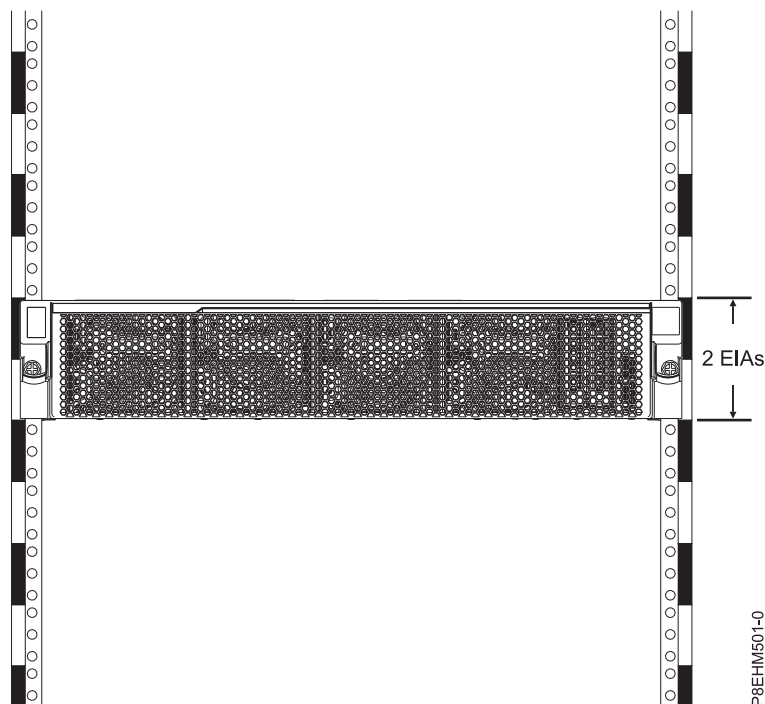

3. If necessary, remove the filler panels to allow access to the inside of the rack enclosure where you plan to place the unit, as shown in Figure 1 on page 3.

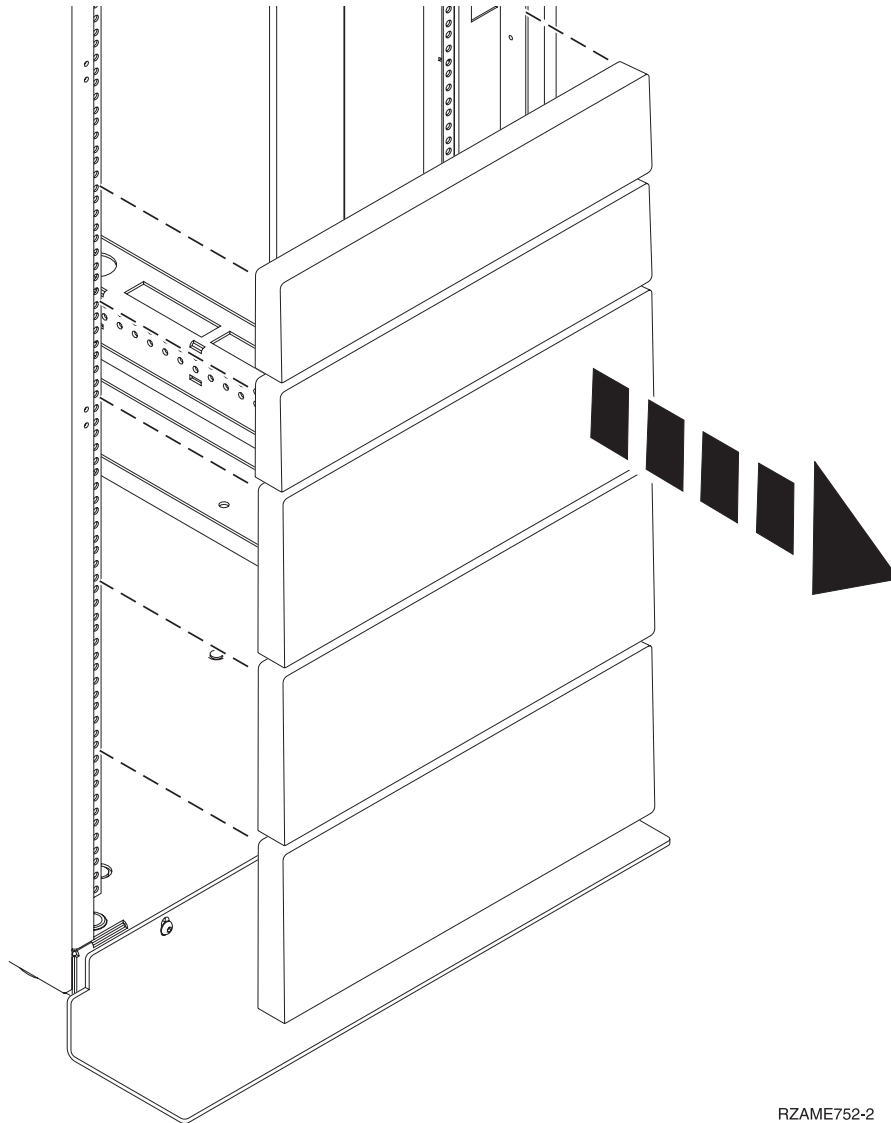

RZAME752-2

Figure 1. Removing the filler panels

4. Determine to place the system in the rack. Record the EIA location.
5. Facing the front of the rack and working from the right side, use tape, a marker, or pencil to mark the lower hole of each EIA unit.
6. Repeat step 5 for the corresponding holes located on the left side of the rack.
7. Go to the rear of the rack.
8. On the right side, find the EIA unit that corresponds to the bottom EIA unit marked on the front of the rack.
9. Mark the bottom EIA unit.
10. Mark the corresponding holes on the left side of the rack.

Installing the system using the slide rails

If you ordered the system with the slide rail option, read this section to install the system into the rack using the slide rails.

Attaching the slide rails to the rack

You might need to attach the mounting hardware to the rack. Use the procedure to complete this task. The information is intended to promote safety and reliable operation, and includes illustrations of the related hardware components and shows how these components relate to each other.

About this task

Attention: To avoid rail failure and potential danger to yourself and to the unit, ensure that you have the correct rails and fittings for your rack. If your rack has square support flange holes or screw-thread support flange holes, ensure that the rails and fittings match the support flange holes that are used on your rack. Do not install mismatched hardware by using washers or spacers. If you do not have the correct rails and fittings for your rack, contact your IBM reseller.

Procedure

1. Each slide rail is marked with either an R (right) or an L (left), when you look from the front. Select the left slide rail, bring it to the rear of the rack, and locate the selected EIA unit that was previously marked.
2. Remove the screw from the rear of the rail (3). Align the two pins located on the rear of the slide rail with the top and bottom holes within the selected EIA unit that were previously marked. Pull the slide rail toward you to insert the two pins into the rack holes (1), and lower the slide rail down (2) to engage the hook feature on the top pin. For details, see Figure 2. Ensure that the two pins protrude through the rack holes before you proceed to the next step.

Note: The pin fixtures of the slide rails support either round-hole or square-hole rack models.

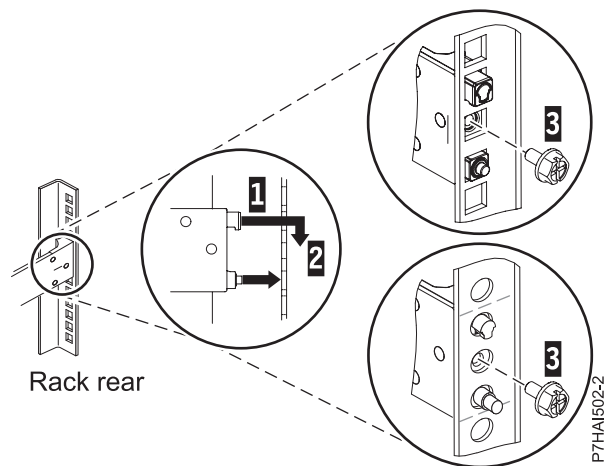

Figure 2. Aligning and engaging the pins into the holes in the rear of the rack

3. Move to the front of the rack. Push up on the locking tab (1) on the front of the rail, and pull out the front latch (2) at the front of the rail. For details, see Figure 3 on page 5.

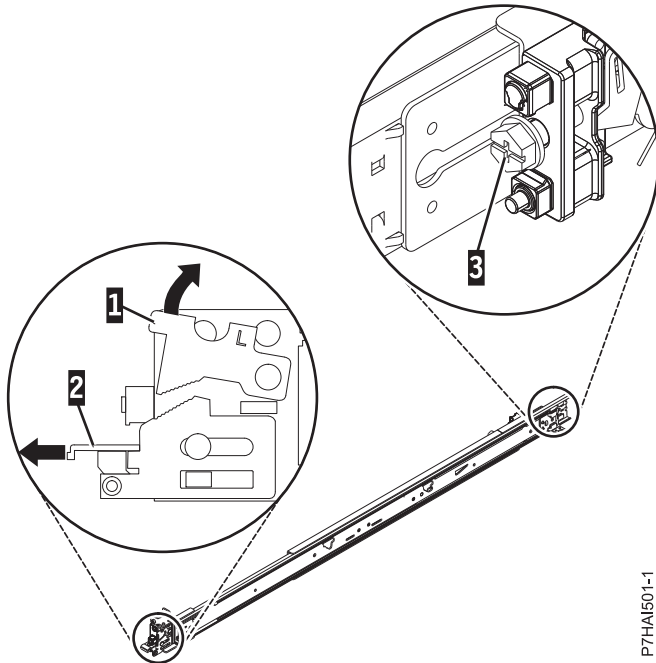

Figure 3. Opening the front latch

4. At the front of the rack, insert three pins on the front of the rail into the holes within the selected EIA unit that were previously marked. Lower the slide rail down (1) to engage the hook feature on the middle pin. For details, see Figure 4.

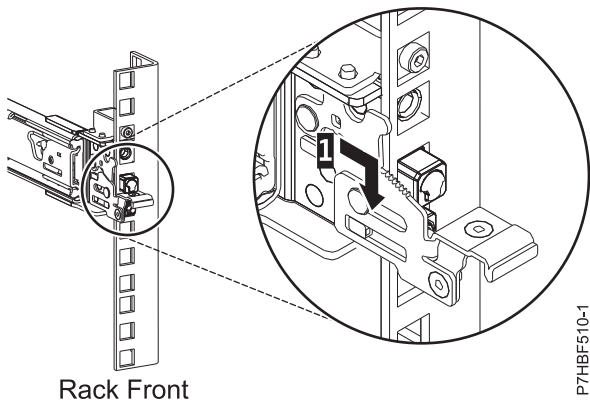

Figure 4. Pins that are seated on the front rail of the rack

5. While you pull the slide rail forward, ensure that all three pins protrude through the rack holes, then push the front latch (2) all the way in. For details, see Figure 5 on page 6.

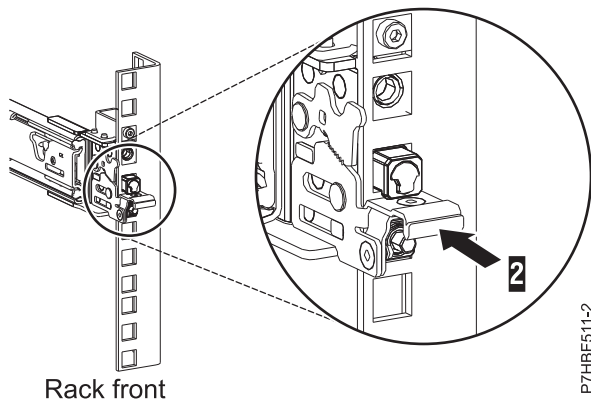

Figure 5. Latch seated on the front rail of the rack

Note: If you must reposition the rail, release the front latch (2), and while you press the blue pin at the bottom, push the rail up and toward the rear to release from the rack.

6. Move to the rear of the rack. Install the screw (3) to secure the slide rail to the rack.
7. Repeat these steps to install the right rail into the rack.

Installing the system into the rack by using the slide rails

Learn how to install the system into the rack by using the slide rails.

About this task

Note: This system requires two people to install the system into the rack.

Procedure

1. Remove the shipping cover on the rear and the front of the system, if present.
2. Extend the slide rails forward (1) until they click twice into place. Carefully lift the server and tilt it into position over the slide rails so that the rear nail heads (2) on the server line up with the rear slots (3) on the slide rails. Slide the server down until the rear nail heads slip into the two rear slots. Then, slowly lower the front of the server (4) until the other nail heads slip into the other slots on the slide rails. Ensure that the front latch (5) slides over the nail heads.

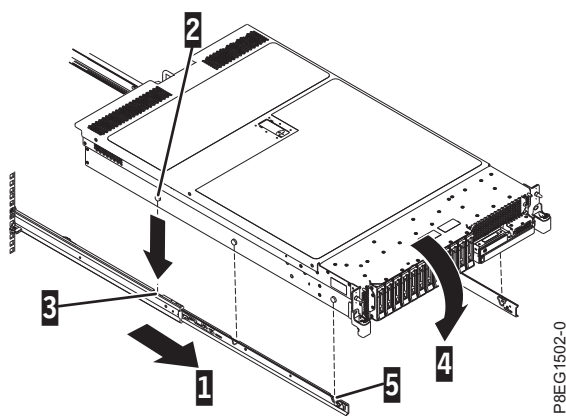

Figure 6. Extending slide rails and aligning server nail heads with the slots on the rail

3. Lift the blue release latches (1) on the slide rails and push the server (2) all the way into the rack until it clicks into place. For details, see Figure 7 on page 7.

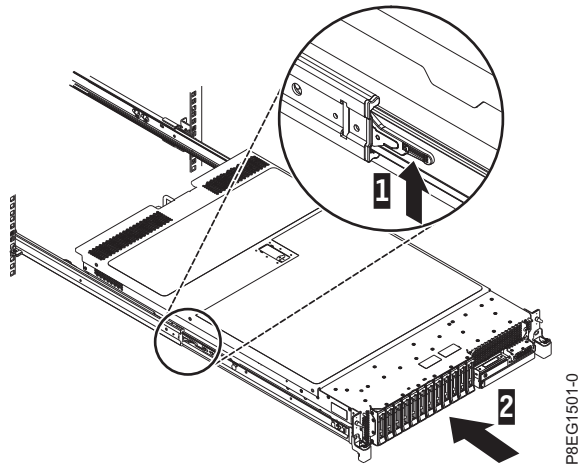

Figure 7. Lifting the release latches and pushing the server into the rack

4. Install the screws on either side of the system to secure the system to the rack.
5. Attach the front cover to the front of the system.

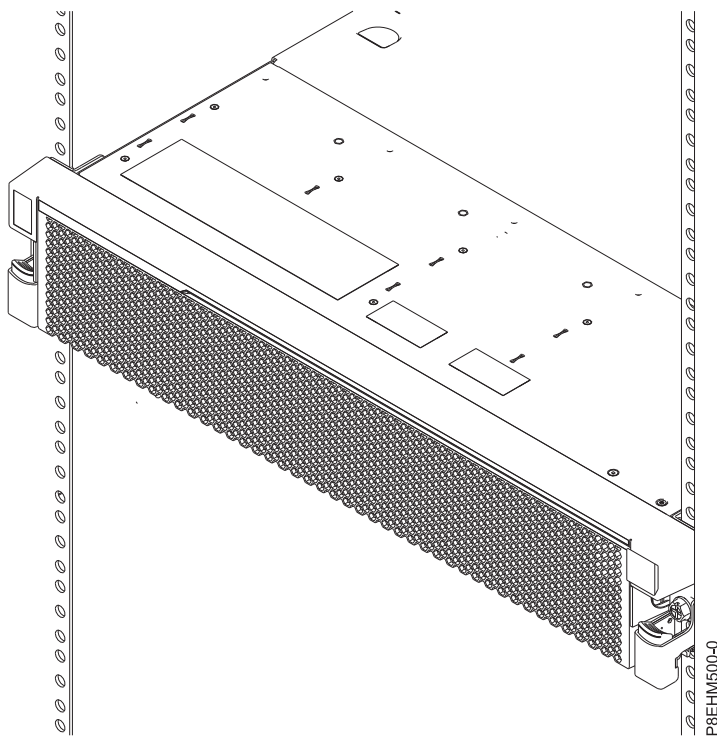

Figure 8. The server installed in the rack

Installing the cable-management arm and connecting and routing power cables

The cable-management arm is used to efficiently route cables so that you have proper access to the rear of the system. After you have installed the cable-management arm, connect and route power cables.

About this task

Note: If you are installing more than one system at this time, install the cable-management arm after you have installed the other systems into the rack.

Procedure

1. Ensure that you have the following parts.

- A** Support arm
- B** Cable-management stop bracket
- C** Mounting bracket
- D** Cable-management arm
- E** Extension bracket

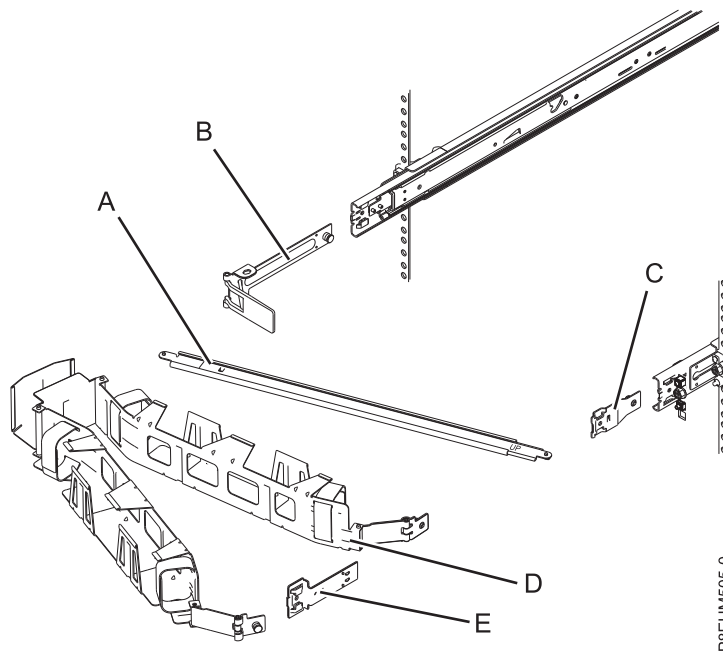

Figure 9. Relative positions of the parts of the cable-management arm before assembly

2. Connect one end of the support arm (**A**) to the right slide rail (**1**) so that you can swing the other end of the support arm toward the left side of the rack (**2**).

Note: The support arm (**A**) is labeled UP and DOWN. Ensure that the side labeled UP is facing upward and to the right.

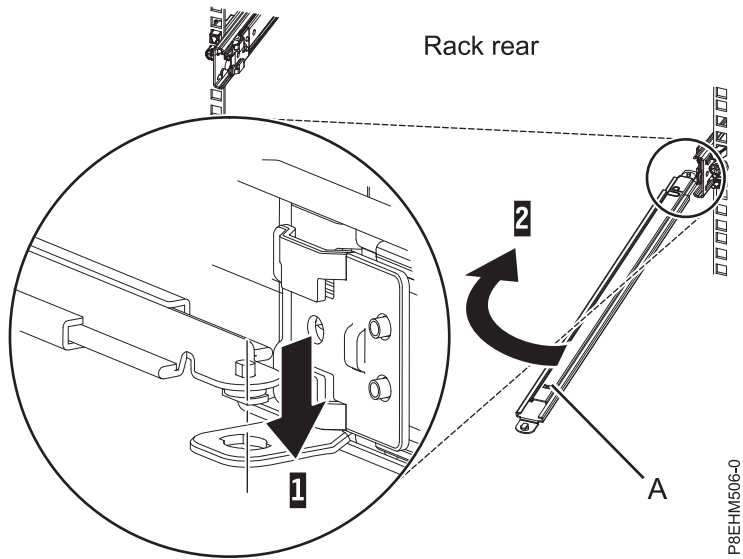

Figure 10. Connecting the support arm

3. Locate the hole at the bottom inside corner of the L-shaped cable-management stop bracket (**B**). Position the unattached end of the support arm so that the locking tab on the underside of its tip aligns with the bracket hole. Insert the tab into the hole (**1**) and turn the bracket (**2**) to secure it to the support arm. For details, see Figure 11.

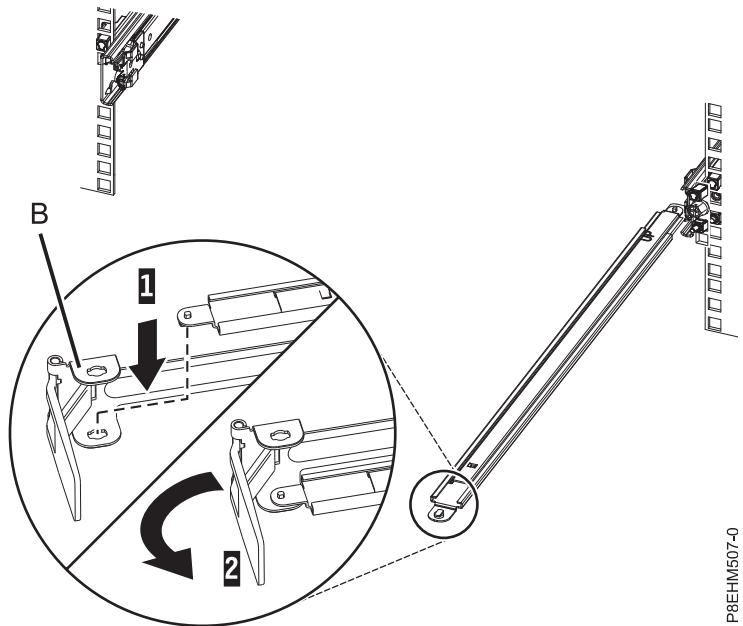
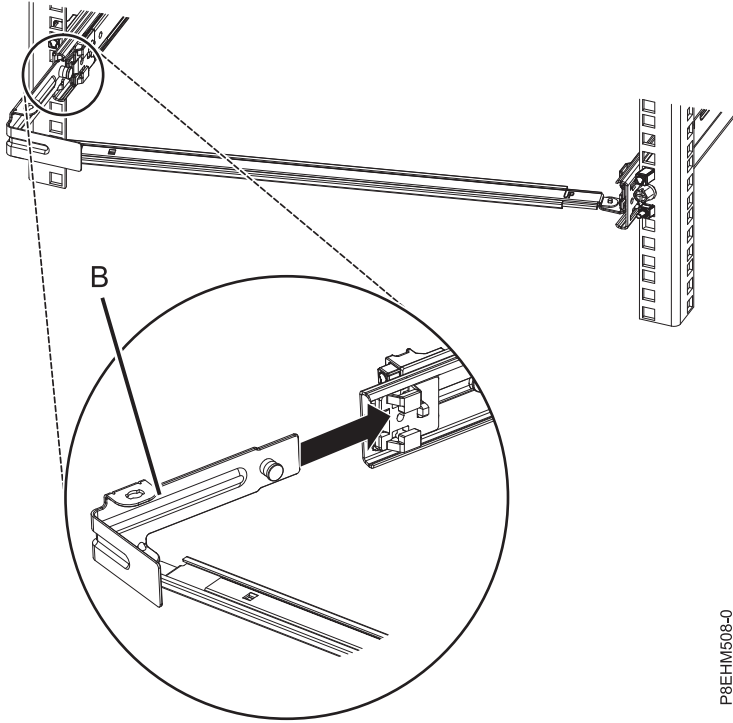

Figure 11. Securing the cable-management stop bracket to the support arm

4. Attach the cable-management stop bracket (**B**) to the slot on the inside of the left slide by sliding the stop bracket (**B**) into the slide rail until the spring-loaded pin snaps into place.



P8EHM508-0

Figure 12. Installing the mounting bracket into the slide rail

- Slide the extension bracket (E) into the right slide rail until the spring-loaded pin snaps into place. For details, see Figure 13.

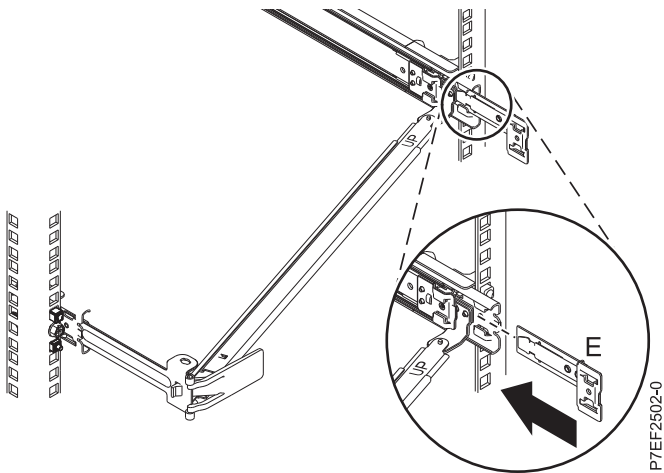

P7EF2502-0

Figure 13. Installing the extension bracket into the slide rail

- Attach the mounting bracket (C) to the slot on the inside of the right slide by sliding the mounting bracket (C) into the slide rail until the spring-loaded pin snaps into place. For details, see Figure 14 on page 11.

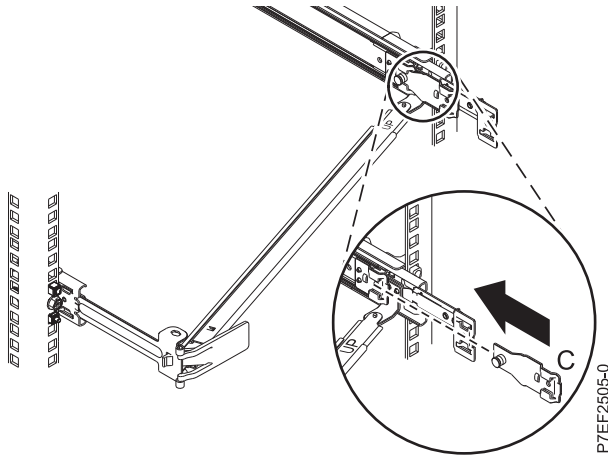

Figure 14. Installing the mounting bracket into the slide rail

7. Place the cable-management arm (D) on the support arm (A). Slide the first cable-management arm tab into the slot on the mounting bracket (C). Push the tab until the spring-loaded latch snaps into place. Slide the other cable-management arm tab into the extension bracket (E) on the outside of the right slide rail (2). Push the tab until the spring-loaded latch snaps into place. For details, see Figure 15 and Figure 16 on page 12.

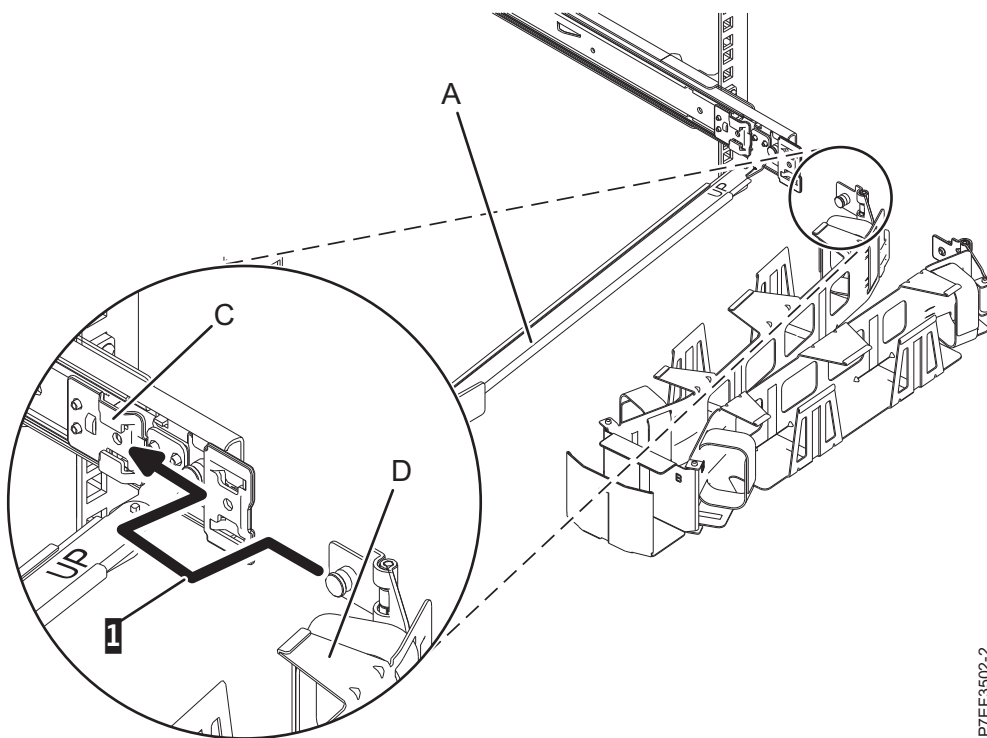
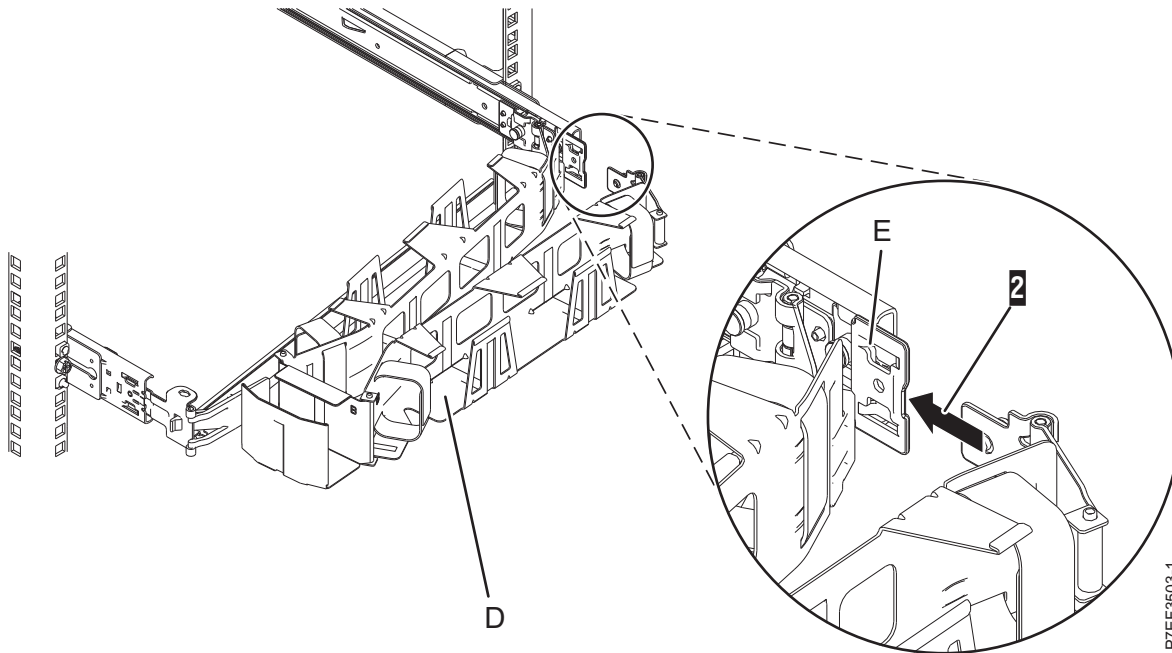

Figure 15. Sliding the cable-management arm tab into the mounting bracket slot



P7EF3503-1

Figure 16. Sliding the other cable-management arm tab into the extension bracket

8. To connect the power cables, complete the following steps:
 - a. Plug the power cords into the power supplies.
 - b. Route the power cords and other cables on the cable-management arm.
 - c. Attach all cables to the rear of the server.

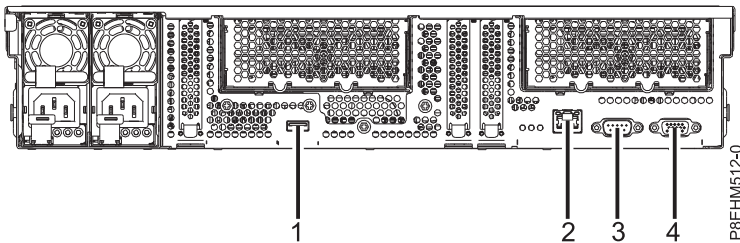

Figure 17. Rear view of the system with ports displayed

Table 1. Port callouts

Identifier	Description
1	USB 3.0
2	Ethernet
3	Intelligent Platform Management Interface (IPMI)
4	Video Graphics Array (VGA). Text based capability is only supported at this time.

- d. Plug the system power cords and the power cords for any other attached devices into the alternating current (ac) power source.
9. Continue with “Completing server setup” on page 16.

Installing the system using the fixed rails

If you ordered the system with the fixed rail option, read this section to install the system into the rack using the fixed rails.

Attaching the fixed rails to the rack

If you have fixed rails, you might need to install them into the rack. Use this procedure to perform this task.

About this task

Note: The system requires 2 EIA rack units (2U) of space.

If present, use the rack-mount template to determine and mark the location, and to attach the mounting hardware to the rack.

Procedure

1. Select the appropriate EIA location unit number for the rails. Each EIA location contains three (3) holes for mounting hardware. For the purpose of these instructions, each EIA set of holes are identified as **a**, **b**, and **c**, from the top of each EIA unit to the bottom of each EIA unit.
2. Rotate the locking clamps downward at each end of both rails, to the open position.

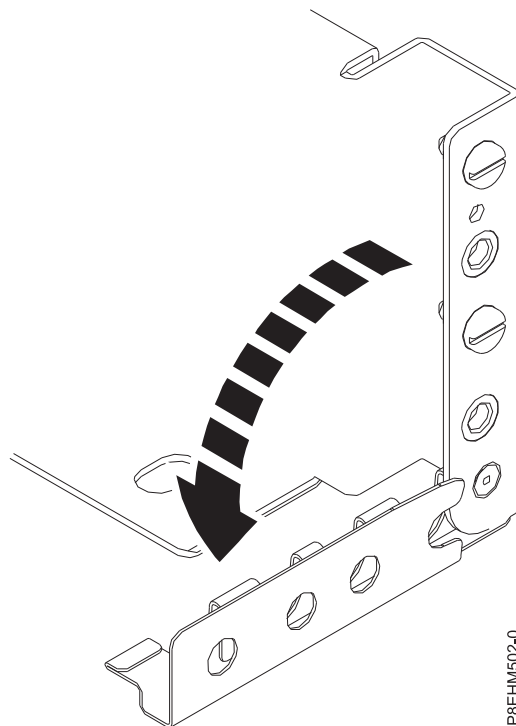

Figure 18. Opening the rail clamps

Note: The rails are marked with an **L**, to designate the left rail, and an **R**, to designate the right rail.

Note: You might have to move the alignment pins in the fixed rails before installing the rails in the rack.

3. At the rack front, align the bottom of the right rail with the bottom hole (**c**) of the EIA unit selected, in both the front of the rack and the rear of the rack. The locator pins (**A**) fit into holes (**b**) and (**c**) of

the EIA location directly above the lowest EIA unit used, on both the front and the rear of the rack.

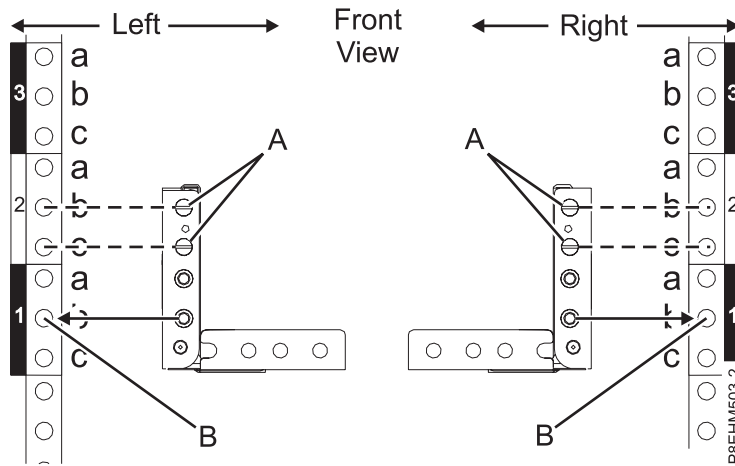

Figure 19. Front of rack rail alignment and nut clip locations

4. Rotate the hinged rail latch upward to hold the rail in place against the front EIA support flange.
5. Repeat steps 1 through 5 for the left rail.
6. Secure both rails to the front EIA support flange (B) by using two M5 x 16mm screws
7. At the rear of the rack, rotate the hinged rail latch upward to hold each rail in place against the rear EIA support flange.

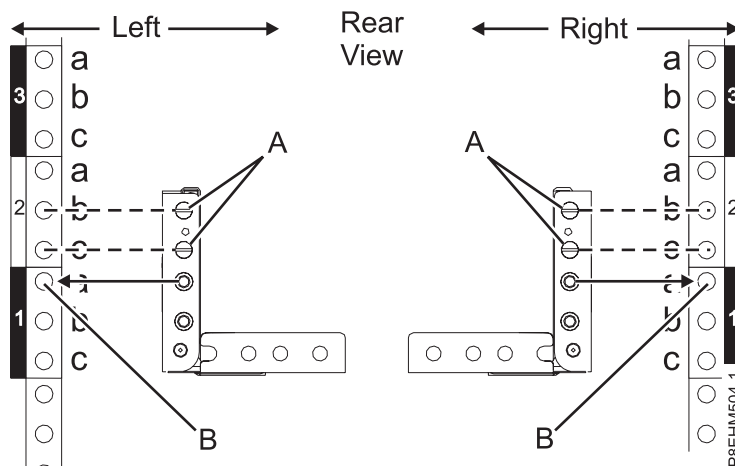

Figure 20. Rear of rack rail alignment and nut clip locations

8. Secure both rails to the rear EIA support flanges (B) by using four M5 x 16mm screws.

Installing the system into the rack by using the fixed rails and connecting power cables

Learn how to install the system into the rack by using the fixed rails and how to connect power cables.

About this task

Note: This system requires two people to install the system into the rack.

Procedure

1. Remove the shipping cover on the rear and the front of the system, if present.
2. Position one person on the left side of the system and one person on the right side of the system .
3. Complete the following steps:
 - a. Lift the system.
 - b. Tilt the system into position over the fixed rack rails.
 - c. Carefully lower the system until the rear of the system rests on the rails.
4. While one person is supporting the weight of the system, have the second person move to the front of the system and push the system all the way into the rack.
5. Attach the front cover to the front of the system.

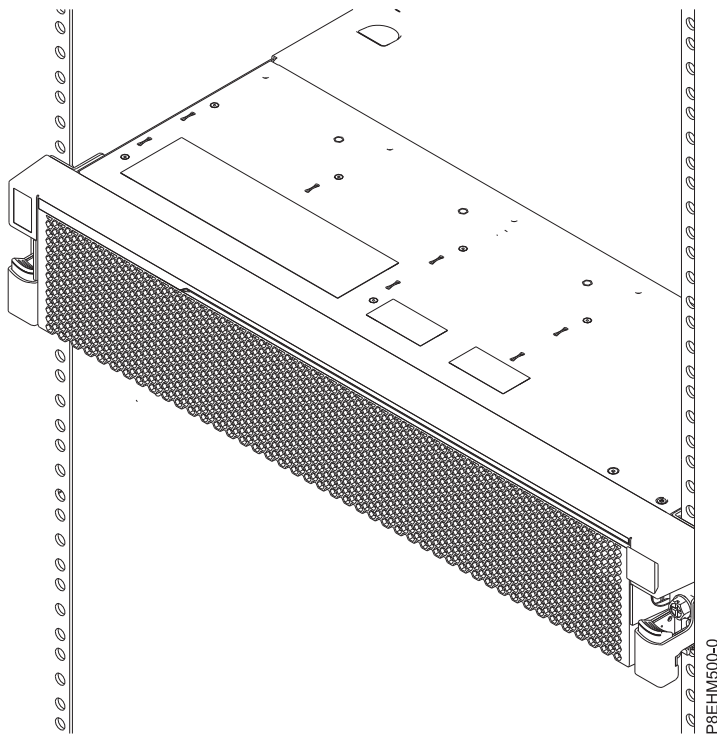

Figure 21. The server installed in the rack

6. Install the screws on either side of the system to secure the system to the rack.
7. Plug the power cords into the power supplies.
8. Attach all cables to the rear of the server.

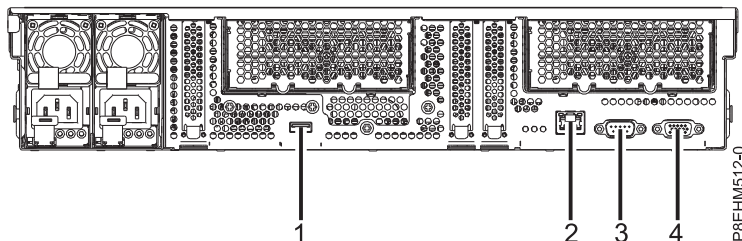

Figure 22. Rear view of the system with ports displayed

Table 2. Port callouts

Identifier	Description
1	USB 3.0
2	Ethernet
3	Intelligent Platform Management Interface (IPMI)
4	Video Graphics Array (VGA). Text based capability is only supported at this time.

9. Plug the system power cords and the power cords for any other attached devices into the alternating current (ac) power source.
10. Continue with "Completing server setup."

Completing server setup

Learn how to complete server setup.

Procedure

1. Connect your server to a VGA terminal and keyboard or a console. Only the 1024x768 at 60 Hz VGA setting is supported. Only up to a 3 meter cable is supported.
2. Go to Getting fixes (http://www.ibm.com/support/knowledgecenter/POWER8/p8ei8/p8ei8_fixes_kickoff.htm) and update the system firmware with the most recent level of firmware.
3. You can receive important technical information and updates for specific IBM Support tools and resources by subscribing to receive updates. To subscribe to receive updates, complete the following steps:
 - a. Go to the IBM Support Portal.
 - b. Log in by using your IBM ID and password and click **Sign in**.
 - c. Click **Support notifications**.
 - d. Click **Browse for a product**.
 - e. Select **Power > Firmware**, find your machine type and model and click **Subscribe**.
 - f. Exit the **Browse for a product** screen.
 - g. Click **Delivery preferences** to set email preferences and click **Submit**.
 - h. Click **Edit** to select the types of documentation updates that you want to receive and click **Submit**.
4. You can install the Linux operating system on bare metal systems, or on non-virtualized systems. For these systems, the operating system runs directly on the Open Power Abstraction Layer (OPAL) firmware. For more information about installing the Linux operating system on bare metal systems, see Installing Linux on bare metal systems (<http://www.ibm.com/support/knowledgecenter/linuxonibm/liabw/liabwkickoff.htm>). For information about how to configure a system that has been preinstalled with Linux, see Configuring Linux that is preinstalled on IBM Power Systems LC servers.

Installing and configuring system features

Learn how to install and configure customer-installable hardware features.

Before you install a feature, ensure that the software that is required to support the feature is installed on the system. For information about software prerequisites, see the IBM Prerequisite website (http://www-912.ibm.com/e_dir/eServerPrereq.nsf). If the required software is not installed, go to the Fix Central website (<http://www.ibm.com/support/fixcentral/>) to download it, and then install it before you continue.

Note: Installing these features is a customer task. You can complete this task yourself, or contact a service provider to complete the task for you. You might be charged a fee by the service provider for this service.

Installing a disk drive in the 8335-GCA or 8335-GTA

Learn how to install a disk drive in the IBM Power[®] System S822LC (8335-GCA and 8335-GTA) system.

Installing a disk drive in the 8335-GCA or 8335-GTA system with the power turned off

To install a disk drive in an IBM Power System S822LC (8335-GCA and 8335-GTA) system with the system power turned off, complete the steps in this procedure.

Installing a disk drive in the 8335-GCA or 8335-GTA system with the power turned off

Follow these steps to install a disk drive in the IBM Power System S822LC (8335-GCA and 8335-GTA) system.

Procedure

1. Ensure that you have the electrostatic discharge (ESD) wrist strap attached. If not, attach it now.
2. If the slot you want to use contains a drive filler, remove the drive filler from the slot.
 - a. Push the lock (A) on the handle of the filler. See Figure 23 on page 18.

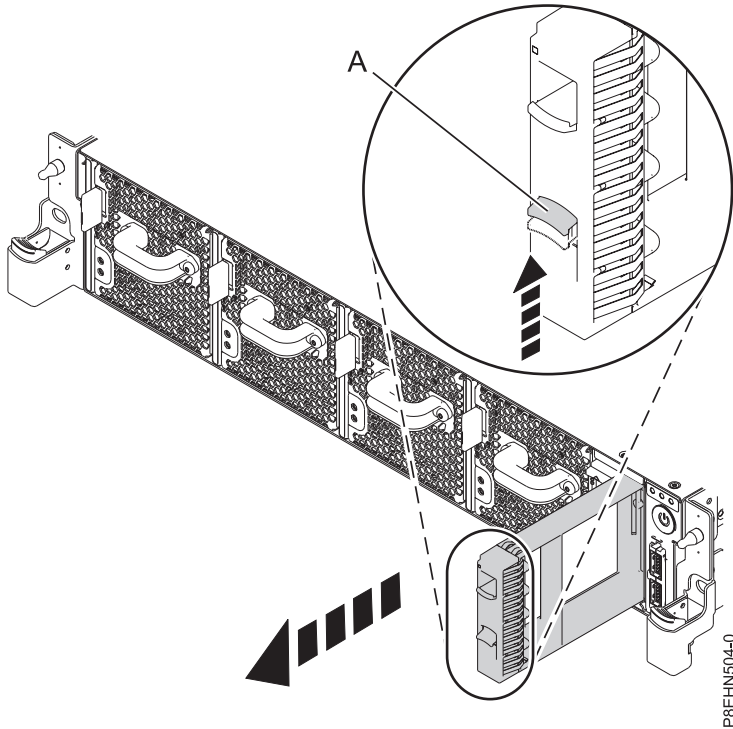

Figure 23. Removing a disk drive filler from a system.

- b. Hold the handle and pull out the filler from the slot.
3. Lock the drive bay handle (A) by pushing in the handle release. See Figure 24.

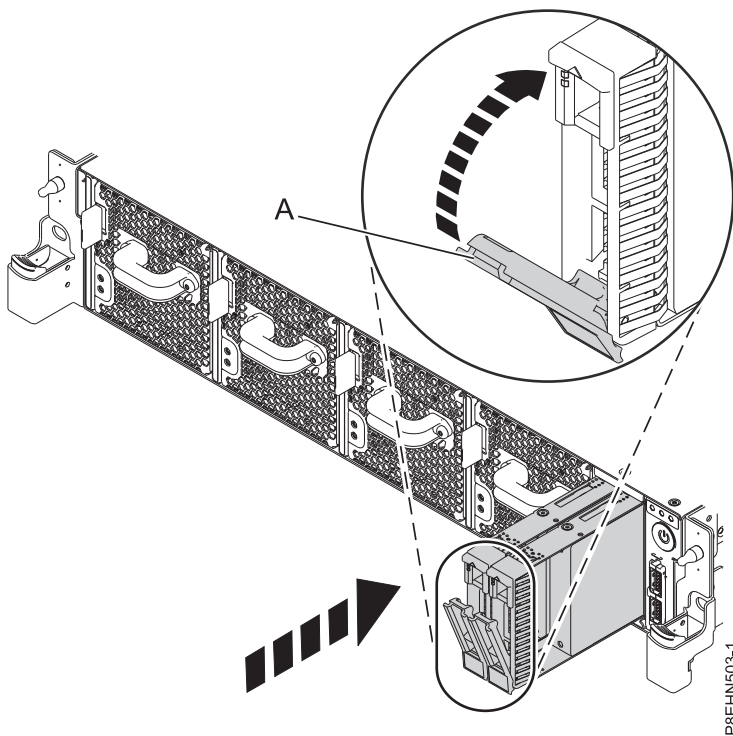

Figure 24. Locking the drive bay handle

4. Hold the drive by the top and bottom edges as you position the drive, and insert it into the drive slot.
5. Slide the drive all the way into the system, and push the drive bay handle (A) in until it locks. See Figure 24 on page 18.

Important: Ensure that the drive is fully seated and is all the way into the system.

Installing a disk drive in the 8335-GCA or 8335-GTA system with the power turned on

Learn how to install a disk drive in an IBM Power System S822LC (8335-GCA and 8335-GTA) system with the system power turned on.

Installing a disk drive in the 8335-GCA or 8335-GTA system with the power turned on

Follow these steps to install a disk drive in the IBM Power System S822LC (8335-GCA and 8335-GTA) system.

Procedure

1. Ensure that you have the electrostatic discharge (ESD) wrist strap attached. If not, attach it now.
2. If the slot you want to use contains a drive filler, remove the drive filler from the slot.
 - a. Push the lock (A) on the handle of the filler. See Figure 25.

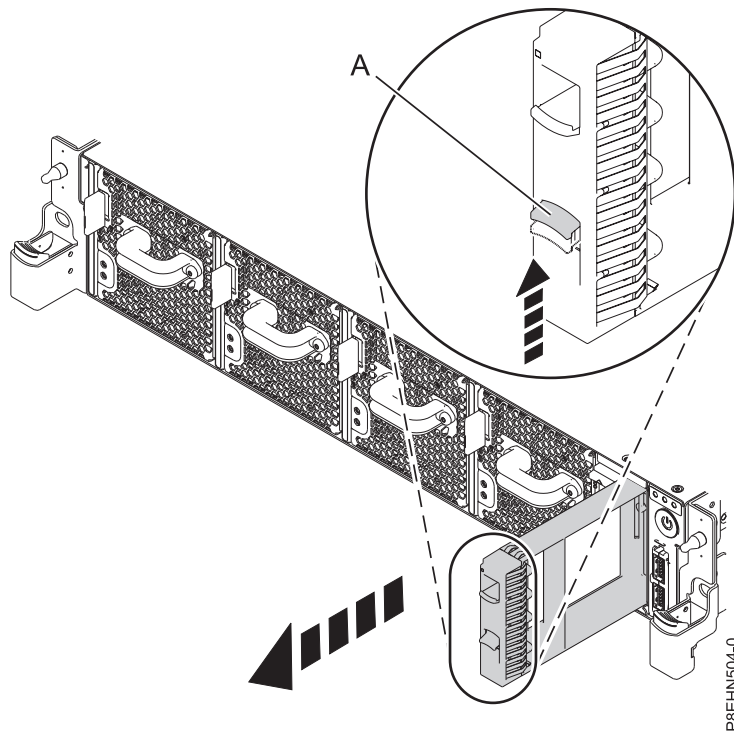

Figure 25. Removing a disk drive filler from a system.

- b. Hold the handle and pull out the filler from the slot.
3. Lock the drive bay handle (A) by pushing in the handle release. See Figure 26 on page 20.

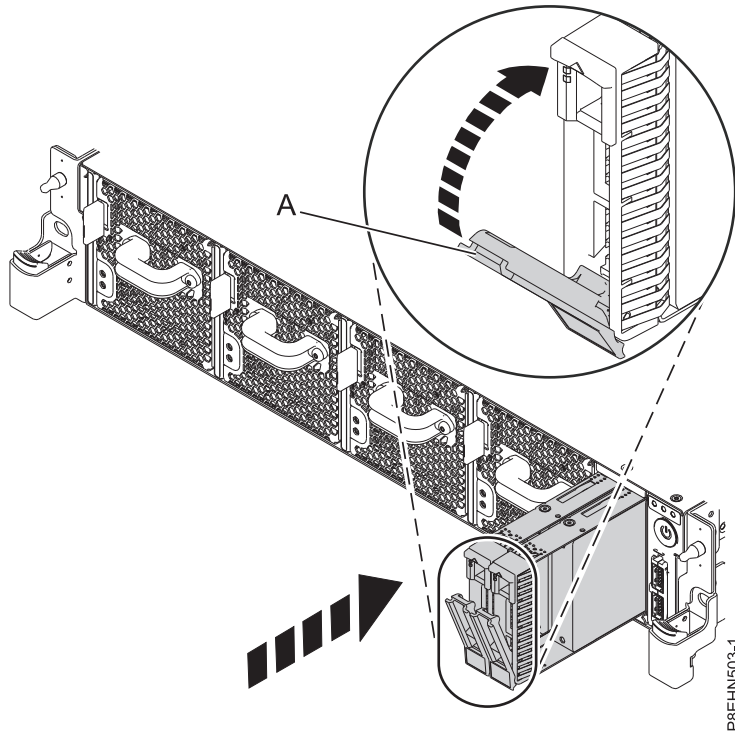

Figure 26. Disk drive lock detail

4. Hold the drive by the top and bottom edges as you position the drive, and insert it into the drive slot.
5. Slide the drive all the way into the system, and push the drive bay handle (A) in until it locks. See Figure 26.

Important: Ensure that the drive is fully seated and is all the way into the system.

Installing the graphics processing unit in the 8335-GCA or 8335-GTA system

Follow these steps to install a graphics processing unit in the IBM Power System S822LC (8335-GCA and 8335-GTA) system.

About this task

Attention: For safety and airflow purposes, if you remove parts from the system, you must ensure that:

- PCIe tailstock fillers are present
- Graphic processor unit (GPU) or PCIe carriers are present and that either GPU or PCIe fillers are installed in the carriers.

Procedure

1. Ensure that you have the electrostatic discharge (ESD) wrist strap attached. If not, attach it now.
2. Using the blue strap and the blue touchpoint, remove the PCIe riser from the system. See Figure 27 on page 21.

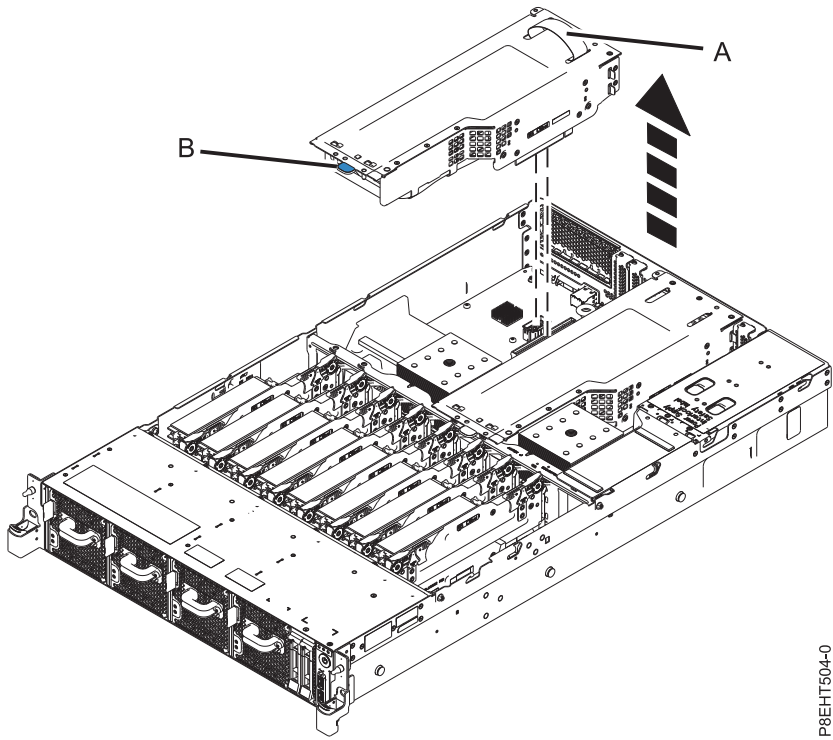

P8EHT504-0

Figure 27. Removing the PCIe riser

- Using the 3 alignment pins, place the PCIe riser containing the GPU into the system. Push it down into place until it is firmly seated in the system. See Figure 28.

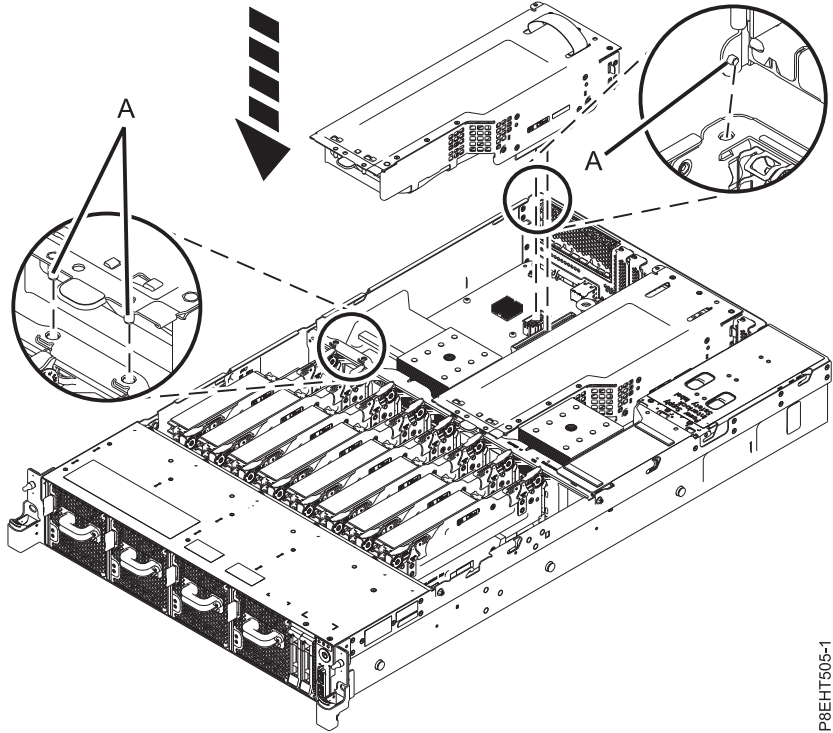

P8EHT505-1

Figure 28. Inserting the PCIe riser

Installing memory in the 8335-GCA

To install memory in the 8335-GCA system, complete the steps in this procedure.

Procedure

1. Ensure that you have the electrostatic discharge (ESD) wrist strap attached. If not, attach it now.
2. Determine the slot in which you want to install the memory riser. See "Plugging rules for memory in the 8335-GCA system" on page 25 to understand the plugging rules and ensure that the memory are plugged in the correct sequence.

Figure 29 shows the location of the memory risers in the system and Figure 30 on page 23 shows the DIMM slot locations on the riser.

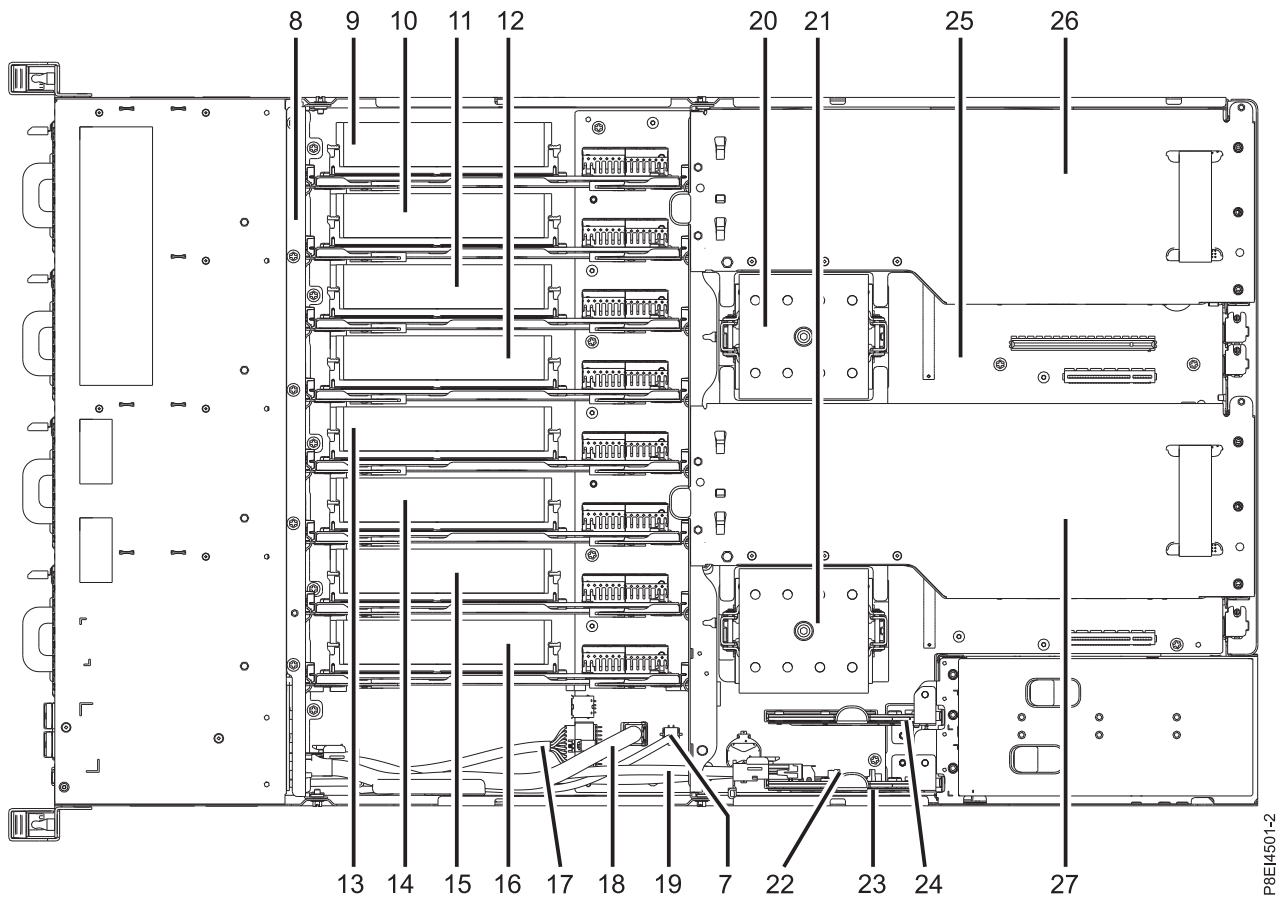

Figure 29. Location of the memory risers: positions 9 through 16

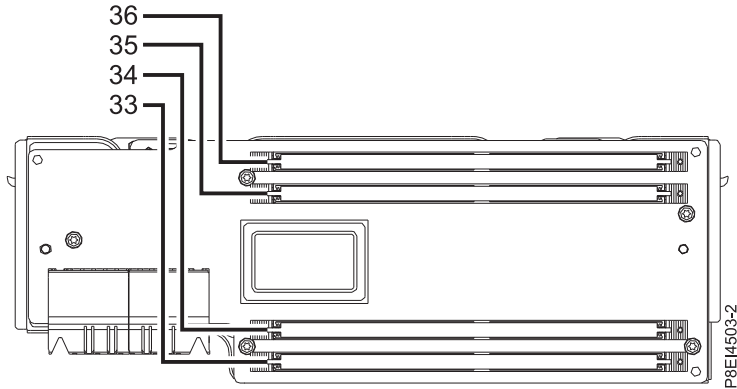

Figure 30. Location of the memory DIMM slots on the riser; positions 33 through 36

3. For each riser you are installing, remove a filler from the target slot. See Figure 31.

Note: Unused memory riser slots must contain a filler to ensure proper cooling.

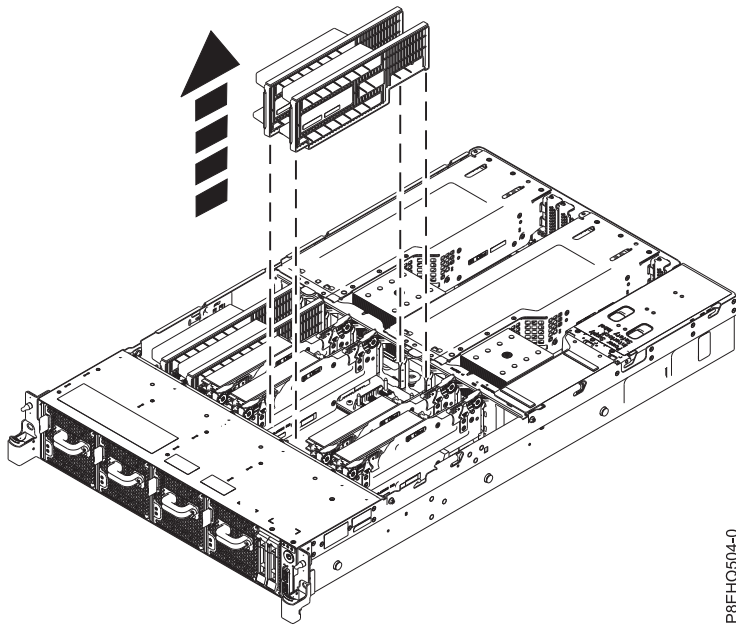

Figure 31. Removing two fillers from the system

4. To install memory DIMMs into the slots on the memory riser, complete the following steps:
 - a. Push the locking tabs to the open position, away from the slot, in the direction shown in Figure 32 on page 24.

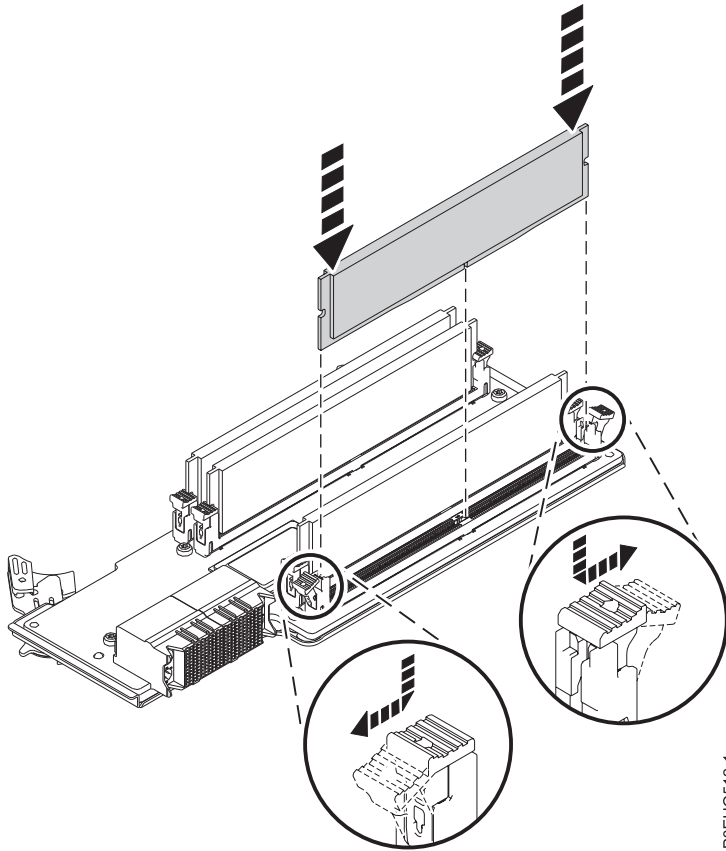
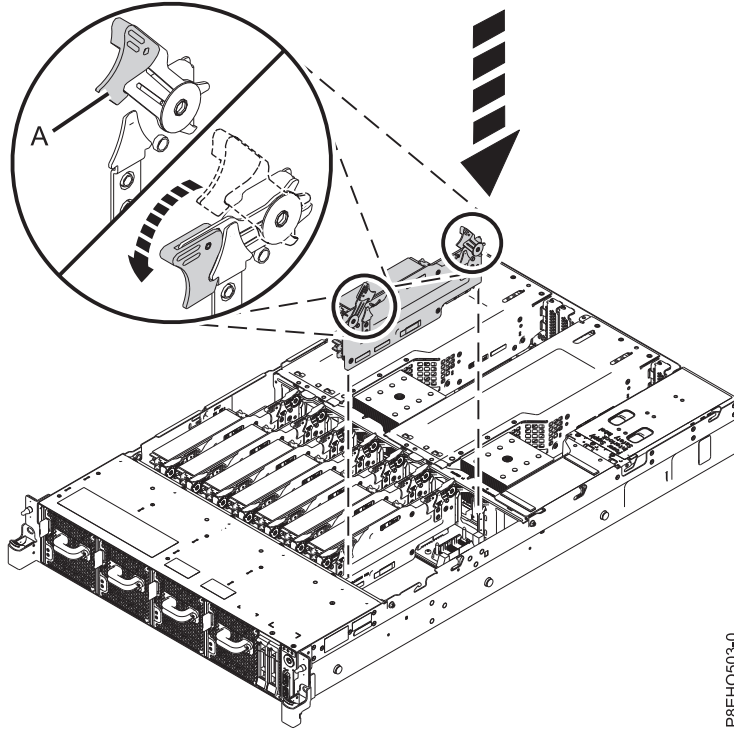

Figure 32. Installing a memory DIMM into a slot on the riser

- b. Grasp the memory DIMM along its edges and align it with the slot on the riser. See Figure 32.

Attention: Memory is keyed to prevent it from being installed incorrectly. Note the location of the key tab within the memory connector before you attempt to install it.
 - c. Press firmly on each side of the memory DIMM until the locking tab locks in place with an audible click.
 - d. Repeat these steps for the remaining memory DIMMs.

Attention: All slots in the riser must be filled with memory DIMM.
5. To install the memory riser, complete the following steps:
 - a. Ensure the release latches are open to about a 60 degree angle, as shown by (A) in Figure 33 on page 25.
 - b. Align the memory riser with the connector.
 - c. Press the riser firmly into the connector.
 - d. Press the release latches into the closed position. See (A) in Figure 33 on page 25.



P8EHQ503-0

Figure 33. Installing a memory riser in the system

Plugging rules for memory in the 8335-GCA system

Learn about the configurations and rules that apply to adding memory to the 8335-GCA system. The 8335-GTA system always has all eight memory risers populated.

Table 3 lists the supported memory DIMM feature codes and Table 4 shows the allowable memory capacity points for the 8335-GCA system. All DIMM slots on a memory riser must be filled. Mixing of memory feature codes is not allowed.

Table 3. Memory DIMM feature codes

Supported feature codes (FC)	Size
EM50	16 GB RDIMMS, 1333 MHZ, 4 GBIT DDR3 DRAM
EM51	32 GB RDIMMS, 1333 MHZ, 4 GBIT DDR3 DRAM
EM52	64 GB RDIMMS, 1333 MHZ, 4 GBIT DDR3 DRAM
EM53	128 GB RDIMMS, 1066 MHZ, 4 GBIT DDR3 DRAM

Table 4. 8335-GCA memory configuration as a function of the number of DIMMs and risers. You read this table by selecting the individual DIMM size row in the leftmost column, then move to the right and select the columns for the memory capacity. The riser quantity value that is listed is the quantity of the memory feature code that can be ordered, which corresponds to the DIMM size in the leftmost column.

DIMM Size	32 GB		64 GB		128 GB		256 GB		512 GB		1024 GB	
	DIMMs	Risers	DIMMs	Risers	DIMMs	Risers	DIMMs	Risers	DIMMs	Risers	DIMMs	Risers
4 GB	8 ¹	2	16 ²	4	32	8						
8 GB			8 ¹	2	16 ²	4	32	8				

Table 4. 8335-GCA memory configuration as a function of the number of DIMMs and risers (continued). You read this table by selecting the individual DIMM size row in the leftmost column, then move to the right and select the columns for the memory capacity. The riser quantity value that is listed is the quantity of the memory feature code that can be ordered, which corresponds to the DIMM size in the leftmost column.

DIMM Size	32 GB		64 GB		128 GB		256 GB		512 GB		1024 GB	
	DIMMs	Risers	DIMMs	Risers	DIMMs	Risers	DIMMs	Risers	DIMMs	Risers	DIMMs	Risers
16 GB					8 ¹	2	16 ¹	4	32	8		
32 GB											32	8

Notes:

1. Default configurations for the listed memory capacity
2. Field upgrade for the 64 GB configuration

The memory risers must be installed in the sequence: (1), then (2), then (3), as shown in Figure 34. By default, the first positions (1) are always populated.

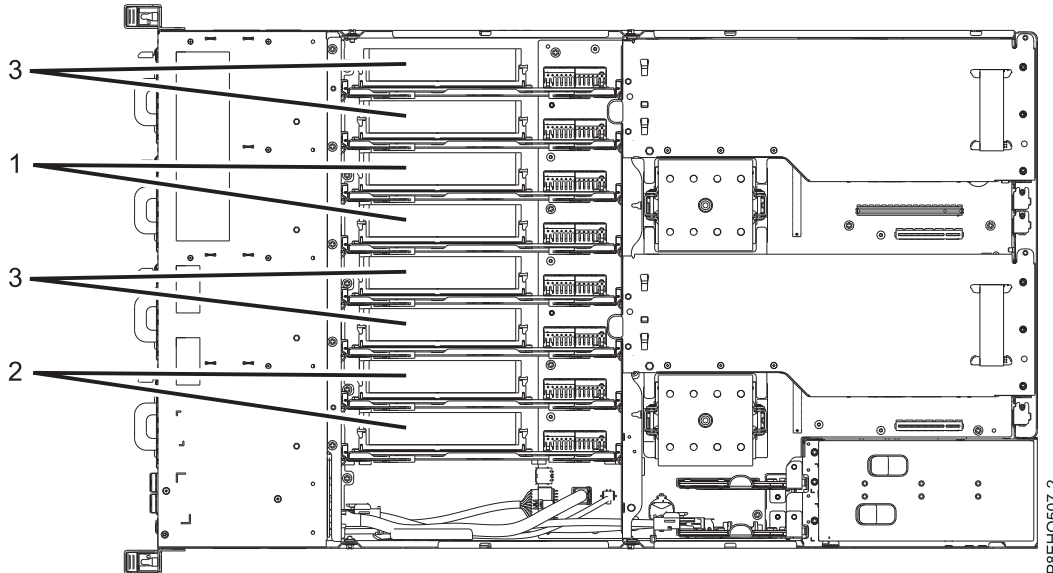

Figure 34. Installation sequence for 8335-GCA memory risers

Installing PCIe adapters in the 8335-GCA or 8335-GTA

Learn how to install Peripheral Component Interconnect (PCI) Express (PCIe) adapters in the IBM Power System S822LC (8335-GCA and 8335-GTA) system.

The 8335-GCA system has three open PCIe slots on the system board. The 8335-GTA system has those slots as well as two open slots in the PCIe risers.

You can install half-height, half-length (HHLH) PCIe adapters in the system board. You can install full-height, full-length (FHFL) PCIe adapters in a PCIe riser. The PCIe riser also supports double-wide PCIe adapters. One of the system board PCIe slots supports double-wide PCIe adapters.

If you need to change the tailstock of the PCIe adapter from one size to another, so that the adapter fits properly in the socket, see Removing and replacing the tailstock on a PCIe adapter.

The following features are electromagnetic compatibility (EMC) Class B features. See the Class B Notices in the Hardware Notices section.

Table 5. Electromagnetic compatibility (EMC) Class B features

Feature	Description
EC49	PCIe Gen3 x16 GPU Adapter
EL3Z	PCIe2 LP 2-port 10 GbE BaseT RJ45 Adapter

PCIe adapter placement rules and slot priorities for the 8335-GCA or 8335-GTA

Find information about the placement rules and slot priorities for the Peripheral Component Interconnect (PCI) Express (PCIe) adapters that are supported for the 8335-GCA or 8335-GTA system.

PCIe slot descriptions for the 8335-GCA or 8335-GTA

The 8335-GCA or 8335-GTA system provides PCIe generation 3 slots. Table 6 lists the PCIe adapter slot locations and details for the 8335-GCA or 8335-GTA system. Figure 35 shows the rear view of the system with the PCIe adapter slots.

- The full-height, full-length adapters can be installed only in the full-height, full-length slots 1 and 4.
- The half-height, half-length or short (low-profile) adapters can be installed in slots 2, 3, and 5.

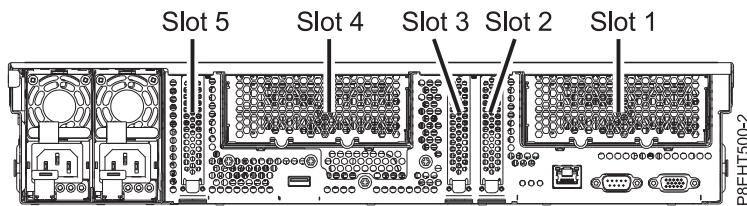

Figure 35. Rear view of an 8335-GCA or 8335-GTA system with PCIe slots indicated

Table 6. PCIe slot locations and descriptions for the 8335-GCA or 8335-GTA system

Slot	Description	PCI host bridge (PHB)	Adapter size	Coherent Accelerator Processor Interface (CAPI)	Slot availability in	
					8335-GCA	8335-GTA
1 ^{1, 2, 3}	PCIe3, x16	Processor Module 2, PHB0	Full-height, full-length	Yes	Yes ²	Yes ³
2	PCIe3, x16	Processor Module 2, PHB1, PHB2	Half-height, half-length	Yes	Yes	Yes
3 ⁴	PCIe3, x8 ⁴	Processor Module 1, PHB1, PLX switch	Half-height, half-length	No	Yes	Yes
4 ^{1, 2, 3}	PCIe3, x16	Processor Module 1, PHB0	Full-height, full-length	Yes	Yes ²	Yes ³

Table 6. PCIe slot locations and descriptions for the 8335-GCA or 8335-GTA system (continued)

Slot	Description	PCI host bridge (PHB)	Adapter size	Coherent Accelerator Processor Interface (CAPI)	Slot availability in	
					8335-GCA	8335-GTA
5 ⁴	PCIe3, x8 ⁴	Processor Module 1, PHB2	Half-height, half-length	Yes	Yes	Yes

¹Slots 4 and 1 are made available by the internal PCIe riser.

²Slots 4 and 1 can be filled with a PCIe3 x16 graphics processing unit (GPU) adapter (FC EC49) or a full-height, full-length adapter in the 8335-GCA. Mixing of a GPU adapter and a full-height, full-length adapter is supported on this model.

³Slots 4 and 1 must be used to install a GPU adapter (FC EC49) in the 8335-GTA.

⁴Slots 5 and 3 are x8 slots. The adapter priority for these slots is for the high-performance adapters followed by any other adapter.

PCIe adapter placement rules

Use this information to select slots for installing PCIe adapters in the 8335-GCA or 8335-GTA system. Table 7 provides information about the adapters, the slot priorities in the system they are supported on, and the maximum number of adapters that can be installed in the supported system. The link that appears in the feature code column provides more technical information specific to the PCIe adapter.

Table 7. PCIe adapter slot priorities and maximum adapters supported in the 8335-GCA or 8335-GTA system

Feature code	Description	8335-GCA		8335-GTA	
		Slot priorities	Maximum number of adapters supported	Slot priorities	Maximum number of adapters supported
5260	PCIe2 LP 4-port 1 GbE Adapter (FC 5260; CCIN 576F); Adapter FRU number: 74Y4064 <ul style="list-style-type: none"> • PCIe1 or PCIe2 x4 • Short, low-profile • High bandwidth • Four-port 1 Gb Ethernet OS support: Linux operating system	3, 5, 2	3	3, 5, 2	3
5899	PCIe2 4-port 1 GbE Adapter (FC 5899; CCIN 576F); Adapter FRU number: 74Y4064 <ul style="list-style-type: none"> • PCIe2 x8 • Short, with full-height bracket • High bandwidth • Four-port 1 Gb Ethernet OS support: Linux operating system	1, 4	2	Not supported	Not supported

Table 7. PCIe adapter slot priorities and maximum adapters supported in the 8335-GCA or 8335-GTA system (continued)

Feature code	Description	8335-GCA		8335-GTA	
		Slot priorities	Maximum number of adapters supported	Slot priorities	Maximum number of adapters supported
EC3A	PCIe3 LP 2-Port 40 GbE NIC RoCE QSFP+ Adapter (FC EC3A; CCIN 57BD); Adapter FRU number: 00FW105 <ul style="list-style-type: none"> • PCIe3 x8 • Short, low-profile • Extra-high bandwidth, low latency 40 Gb Ethernet • Supports NIC and RoCE services OS support: Linux operating system	2, 5, 3	2	2, 5, 3	2
EC3B	PCIe3 2-Port 40 GbE NIC RoCE QSFP+ Adapter (FC EC3B; CCIN 57BD); Adapter FRU number: 00FW105 <ul style="list-style-type: none"> • PCIe3 x8 • Short, with full-height tailstock • Extra-high bandwidth, low latency 40 Gb Ethernet • Supports NIC and RoCE services • OS support: AIX®, IBM i only with VIOS, and Linux operating systems • VIOS supported; NIC capability only • Supported on Firmware level 8.1 OS support: Linux operating system	1, 4	2	Not supported	Not supported
EC3E	PCIe3 LP 2-port 100 Gb EDR IB Adapter x16 (FC EC3E, CCIN 2CEA); Adapter FRU number: 00WT075 <ul style="list-style-type: none"> • PCIe3, x16 • Short, low-profile • OS support: Linux operating system 	2	1	2	1
EC3T	PCIe3 LP 1-port 100 Gb EDR IB Adapter x16 (FC EC3T; CCIN 2CEB); Adapter FRU number: 00WT013 <ul style="list-style-type: none"> • PCIe generation 3, x16 • Short, low-profile • OS support: Linux operating system 	2	1	2	1
EC49	PCIe3 x16 GPU Adapter (FC EC49; CCIN 2CE9); Adapter FRU number: 00E4485 - S822LC GPU assembly (includes carrier assembly with cable and shield); Cable: 00RR917 <ul style="list-style-type: none"> • PCIe3 x16 • Full-height, full-length • Compute intensive accelerator • Double-wide adapter requires two adjacent slots • OS support: Linux operating system 	4, 1	2	4, 1	2
EC54 ⁵	PCIe3 1.6 TB NVMe Flash Adapter (FC EC54; CCIN 58CB); Adapter FRU number: 00MH991 <ul style="list-style-type: none"> • PCIe3, x4 • Short, low-profile • 1.6 TB of low latency flash memory • OS support: Linux operating systems 	1, 4, 3	2	Not supported	Not supported

Table 7. PCIe adapter slot priorities and maximum adapters supported in the 8335-GCA or 8335-GTA system (continued)

Feature code	Description	8335-GCA		8335-GTA	
		Slot priorities	Maximum number of adapters supported	Slot priorities	Maximum number of adapters supported
EC56 ⁵	PCIe3 3.2 TB NVMe Flash Adapter (FC EC56; CCIN 58CC); Adapter FRU number: 00MH993 <ul style="list-style-type: none"> • PCIe3, x4 • Short, low-profile • 3.2 TB of low latency flash memory • OS support: Linux operating systems 	1, 4, 3	2	Not supported	Not supported
EJ1A	CAPI Compression Accelerator Adapter (FC EJ1A and EJ1B; CCIN 2CF0); Adapter FRU number: 00WT173 <ul style="list-style-type: none"> • PCIe3 x8 • Short, with full-height tailstock (FC EJ1A) • Short, low-profile (FC EJ1B) • Up to 2 GB/sec compression and decompression throughput • CPU offload and CAPI interface with negligible software load • OS support: Linux operating systems 	4, 1	2	Not supported	Not supported
EJ1B	CAPI Compression Accelerator Adapter (FC EJ1A and EJ1B; CCIN 2CF0); Adapter FRU number: 00WT173 <ul style="list-style-type: none"> • PCIe3 x8 • Short, with full-height tailstock (FC EJ1A) • Short, low-profile (FC EJ1B) • Up to 2 GB/sec compression and decompression throughput • CPU offload and CAPI interface with negligible software load • OS support: Linux operating systems 	5, 2	2	5, 2	2
EJ1K	PCIe3 1.92 TB CAPI NVMe Flash Accelerator Adapter (FC EJ1K; CCIN 58CD) <ul style="list-style-type: none"> • PCIe3 x8 • Short, low-profile • 1.92 TB of low-latency flash memory • OS support: Linux Ubuntu operating system 	2	1	Not supported	Not supported
EL3Z	PCIe2 LP 2-port 10 GbE BaseT RJ45 Adapter (FC EL3Z; CCIN 2CC4); Adapter FRU number: 00E2714; Full-height tailstock part number: 00E2862; Low-profile tailstock part number: 00E2721 <ul style="list-style-type: none"> • PCIe2 x8 • Short, low-profile • Two 10 Gb RJ45 ports • Local area network (LAN) adapter <p>OS support: Linux and PowerKVM operating systems</p>	2, 5, 3	3	2, 5, 3	3

Table 7. PCIe adapter slot priorities and maximum adapters supported in the 8335-GCA or 8335-GTA system (continued)

Feature code	Description	8335-GCA		8335-GTA	
		Slot priorities	Maximum number of adapters supported	Slot priorities	Maximum number of adapters supported
EL43	PCIe3 LP 16 Gb 2-port Fibre Channel Adapter (FC EL43; CCIN 577F); Adapter FRU number: 00E3496 <ul style="list-style-type: none"> • PCIe3 x8 • Short, low-profile • Extra-high bandwidth • OS support: Red Hat Enterprise Linux, SUSE Linux Enterprise Server, Linux Ubuntu operating system, and PowerKVM 	2, 5, 3	2	2, 5, 3	2
EL4L	PCIe2 4-port 1 GbE Adapter (FC EL4L and EL4M; CCIN 576F); Adapter FRU number: 74Y4064 <ul style="list-style-type: none"> • PCIe1 or PCIe2 x4 • Short, low-profile (FC EL4L) • Short, with full-height tail stock (FC EL4M) • High bandwidth • Four-port 1 Gb Ethernet • OS support: Linux operating system 	1, 4	2	Not supported	Not supported
EL4M	PCIe2 4-port 1 GbE Adapter (FC EL4L and EL4M; CCIN 576F); Adapter FRU number: 74Y4064 <ul style="list-style-type: none"> • PCIe1 or PCIe2 x4 • Short, low-profile (FC EL4L) • Short, with full-height tail stock (FC EL4M) • High bandwidth • Four-port 1 Gb Ethernet • OS support: Linux operating system 	3, 5, 2	3	3, 5, 2	3
EL55	PCIe2 2-port 10 GbE BaseT RJ45 Adapter (FC EL55; CCIN 2CC4); Adapter FRU number: 00E2714 <ul style="list-style-type: none"> • PCIe2 x8 • Short, with full-height tailstock • Two 10 Gb RJ45 ports • Local area network (LAN) adapter OS support: Red Hat Enterprise Linux and SUSE Linux Enterprise Server	1, 4	2	Not supported	Not supported
EL5B	PCIe3 16 Gb 2-port Fibre Channel Adapter (FC EL5B; CCIN 577F); Adapter FRU number: 00E3496 <ul style="list-style-type: none"> • PCIe3 x8 • Short, with full-height tailstock • Extra-high bandwidth OS support: Linux and PowerKVM operating systems	1, 4	2	Not supported	Not supported

Table 7. PCIe adapter slot priorities and maximum adapters supported in the 8335-GCA or 8335-GTA system (continued)

Feature code	Description	8335-GCA		8335-GTA	
		Slot priorities	Maximum number of adapters supported	Slot priorities	Maximum number of adapters supported
EN0S	PCIe2 4-port (10 Gb + 1 GbE) SR+RJ45 Adapter (FC EN0S; CCIN 2CC3); Adapter FRU number: 00E2715; Part number (Full-height tailstock): 00E2863; Part number (Low-profile tailstock): 00E2720 <ul style="list-style-type: none"> • PCIe2 x8 • Short, with full-height tailstock • two 10 Gb SR optical ports and two 1 Gb RJ45 ports • NIC network convergence adapter • Local are network (LAN) adapter OS support: Linux and PowerKVM operating systems	1, 4	2	Not supported	Not supported
EN0T	PCIe2 LP 4-port (10 Gb + 1 GbE) SR+RJ45 Adapter (FC EN0T; CCIN 2CC3); Adapter FRU number: 00E2715; Low-profile tailstock (PN): 00E2720 <ul style="list-style-type: none"> • PCIe2 x8 • Short, low-profile • Two 10 Gb SR optical ports and two 1 Gb RJ45 ports • NIC network convergence adapter • Local area network (LAN) adapter OS support: Linux and PowerKVM operating systems	2, 5, 3	3	2, 5, 3	3

⁵Any combination of FC EC54 and FC EC56 adapters can be installed using the correct plugging sequence.

Installing a PCIe adapter in the system backplane of a 8335-GCA or 8335-GTA system

Complete the steps in this procedure to install a PCIe adapter in the system backplane.

About this task

See “PCIe adapter placement rules and slot priorities for the 8335-GCA or 8335-GTA” on page 27 for information and capabilities of the PCIe slots.

Attention: For safety and airflow purposes, if you remove parts from the system, you must ensure that:

- PCIe tailstock fillers are present
- Graphic processor unit (GPU) or PCIe carriers are present and that either GPU or PCIe fillers are installed in the carriers.

Procedure

1. Ensure that you have the electrostatic discharge (ESD) wrist strap attached. If not, attach it now.
2. Pick the correct slot for the PCIe adapter. See Figure 36 on page 33.

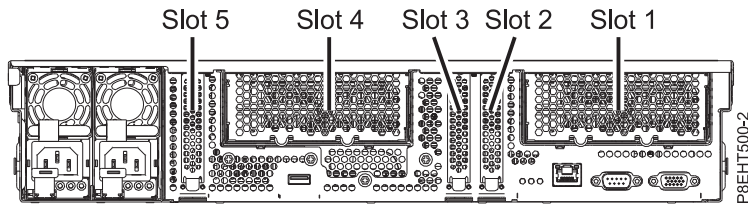

Figure 36. Rear view of a 8335-GCA or 8335-GTA system with PCIe slots indicated

3. Remove the PCIe slot cover. See Figure 37.

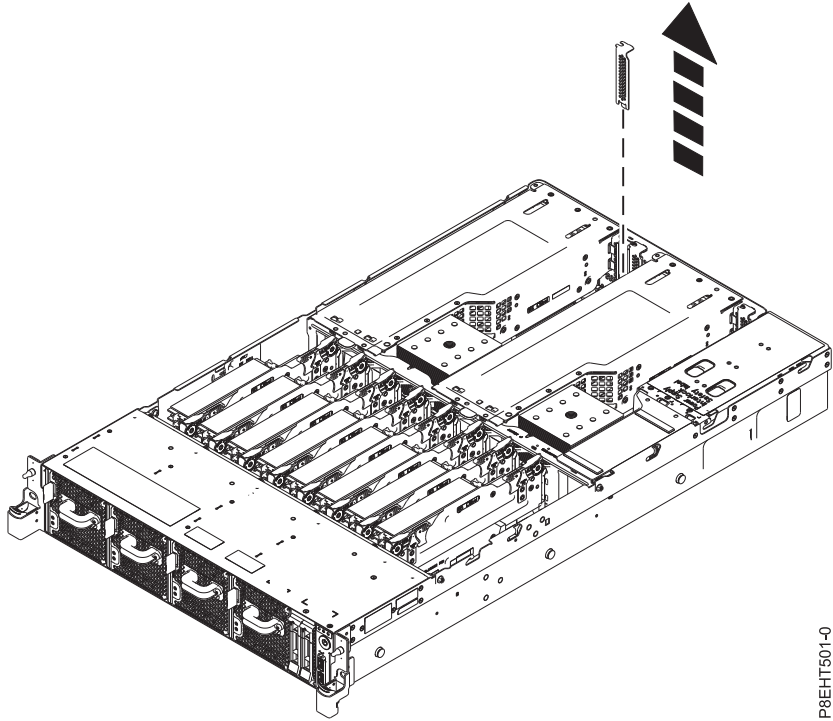

Figure 37. Removing the PCIe slot cover

4. If needed, label and remove any plugs that extend out of the PCIe adapter.
5. Insert the adapter, aligning it properly and inserting it fully into the slot. See Figure 38 on page 34.

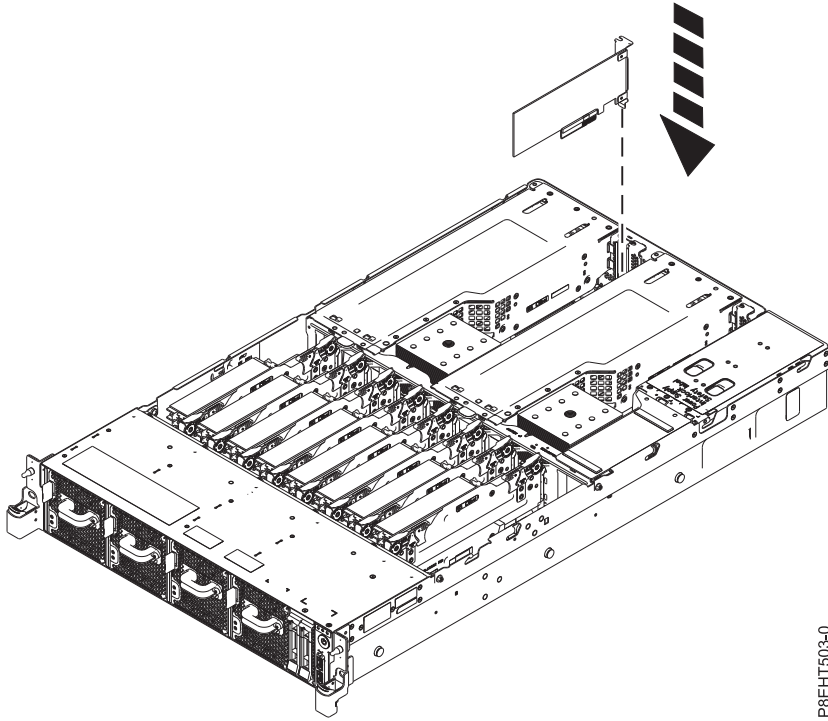

Figure 38. Inserting a PCIe adapter

6. Using your labels, replace any plugs that you removed from the PCIe adapter. Insert the cables into the PCIe adapter.

Installing a PCIe adapter in a PCIe riser in the 8335-GCA or 8335-GTA system

Complete the steps in this procedure to install a PCIe adapter in a PCIe riser.

About this task

Attention: For safety and airflow purposes, if you remove parts from the system, you must ensure that:

- PCIe tailstock fillers are present
- Graphic processor unit (GPU) or PCIe carriers are present and that either GPU or PCIe fillers are installed in the carriers.

Procedure

1. Ensure that you have the electrostatic discharge (ESD) wrist strap attached. If not, attach it now.
2. Using the blue strap and the blue touchpoint, remove the PCIe riser from the system. See Figure 39 on page 35.

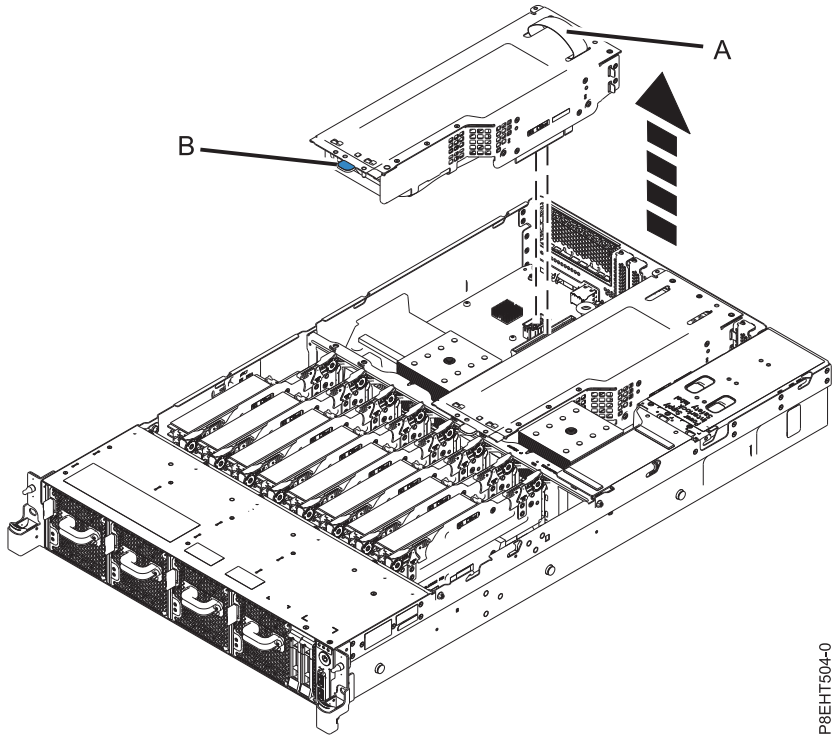

P8EHT504-0

Figure 39. Removing the PCIe riser

3. Place the PCIe riser on the ESD mat on the table.
4. Depending on the size of the PCIe adapter, remove one or both fillers from the carrier. See Figure 40.

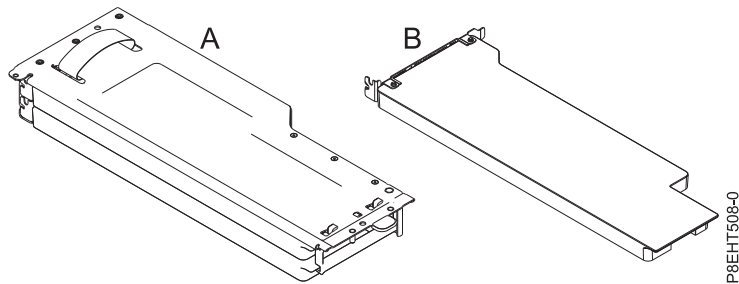

P8EHT508-0

Figure 40. PCIe riser with fillers installed

Option	Description
For a single-wide adapter	Remove the filler over the PCIe slot. For a single-wide adapter, one of the fillers must remain in place to ensure proper airflow and cooling.
For a double-wide adapter	Remove both fillers.

5. If needed, label and remove any plugs that extend out of the PCIe adapter.
6. Insert the card into the PCIe riser, aligning it properly and inserting it fully into the slot. See Figure 41 on page 36.

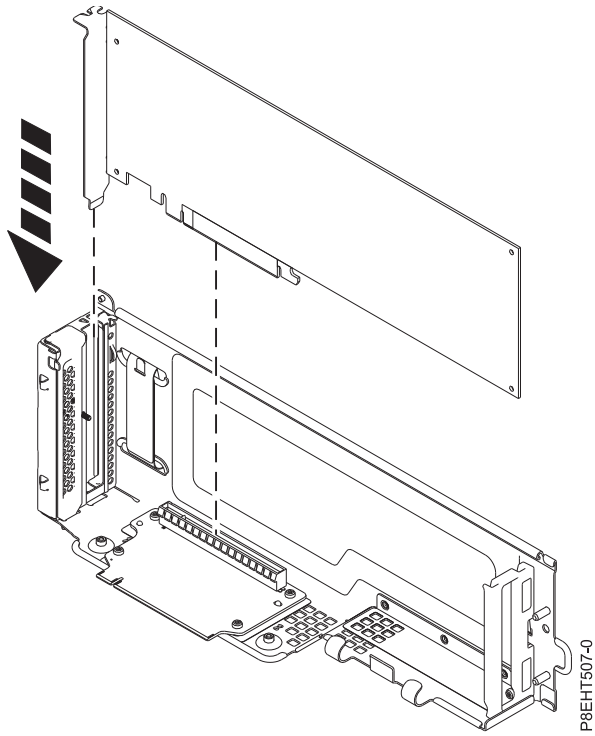
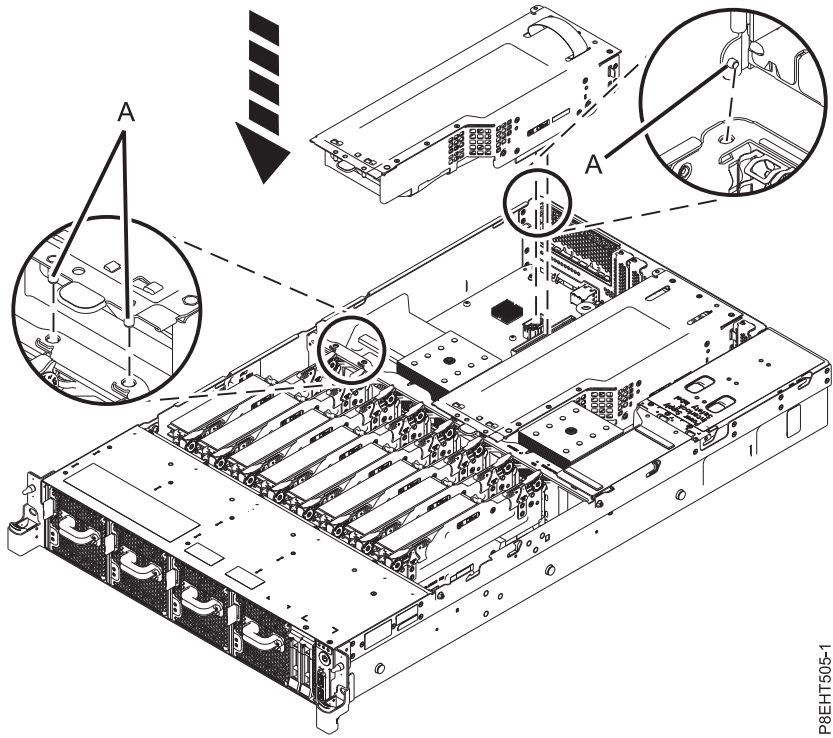

Figure 41. Inserting PCIe adapter into PCIe riser

7. If applicable, secure the auxiliary GPU power cable out of the way inside the riser.
8. Using the 3 alignment pins (A), place the PCIe riser into the system. Push it down into place until it is firmly seated in the system. See Figure 42 on page 37.



P8EHT505-1

Figure 42. Installing the PCIe riser

- Using your labels, replace any plugs that you removed from the PCIe adapter. Insert the cables into the PCIe adapter.

PCIe adapters

Find information about using and managing the Peripheral Component Interconnect (PCI) Express (PCIe) adapters for the 8335-GCA or 8335-GTA system. Also, find information about specifications and installation notes for specific adapters.

PCIe2 LP 4-port 1GbE Adapter (FC 5260; CCIN 576F)

Learn about the specifications and operating system requirements for the feature code (FC) 5260 adapters.

Overview

FC 5260 and FC 5899 are both the same adapter with different feature codes. FC 5260 is a low-profile adapter and the FC 5899 is a full-height adapter.

The PCIe2 LP 4-port 1GbE Adapter is a short, low-profile, generation-2 PCIe adapter. This adapter provides four 1-Gb Ethernet ports that can be configured to run at 1000 megabits per second (Mbps) (or 1 gigabit per second (Gbps)), 100 Mbps, or 10 Mbps. The adapter connects to a network that uses unshielded twisted pair (UTP) cable for distances of up to 100 meters (328.08 feet). The adapter supports AIX Network Installation Management (NIM) boot capability. The adapter conforms to the IEEE 802.3ab 1000Base-T standard. The adapter supports jumbo frames when running at the 1000 Mbps speed.

Each of the Ethernet ports can be connected by using:

- CAT5e (or later) UTP cables for 1000 Mbps network attachment
- CAT5 or CAT3 UTP cables for 100 Mbps or 10 Mbps network attachment

The cables are attached to the copper RJ45 connectors. Each port is independent of one another and supports full-duplex or half-duplex. The half-duplex mode does not support a speed of 1000 Mbps.

The adapter provides the following features:

- Supports interrupt moderation to deliver increased performance while significantly reducing processor utilization
- Supports dual port operation in almost any PCIe slot, except x1
- Supports auto-negotiation, full-duplex only
- Supports integrated media-access control (MAC) and physical layer (PHY)
- Supports Fast EtherChannel (FEC) with the existing software
- Supports gigabit EtherChannel (GEC) with the existing software
- Supports IEEE 802.3ad (Link Aggregation control protocol)
- Supports IEEE 802.1Q VLANs
- Supports IEEE 802.3 z, ab, u, x flow control support
- Supports IEEE 802.1p
- Supports IEEE 802.3ab for TX
- Supports TCP checksum offload transmission control protocol (TCP), user datagram protocol (UDP), Internet Protocol (IP) for IPv4 and IPv6
- Supports TCP segmentation or large send offload
- Supports EEPROM-SPI and single EEPROM
- Supports interrupt levels INTA and MSI
- Hardware certifications FCC B, UL, CE, VCCI, BSMI, CTICK, MIC
- Network Controller (MAC) Intel 82571EB
- Compliant with European Union Directive 2002/95/EC on the Restriction of the Use of Certain Hazardous Substances in Electrical and Electronic Equipment

Specifications

Item Description

Adapter FRU number

74Y4064 (Designed to comply with RoHS requirement)

Wrap plug

10N7405

Note: Wrap plugs are not included with the card and cannot be purchased from IBM.

I/O bus architecture

PCIe2.0 x4

Slot requirement

One PCIe x4 (low-profile) slot.

Cables

4-pair, CAT5e, UTP cables are connected to copper RJ45 connectors.

Voltage

3.3 V

Form factor

short, low-profile

Maximum number

For details about the maximum number of adapters that are supported, see PCIe adapter placement rules and slot priorities (http://www.ibm.com/support/knowledgecenter/POWER8/p8eab/p8eab_mtm_pciplacement.htm) and select the system you are working on.

Connector information

- Two RJ-45 ports
- Two LED adapter status indicators per port, for link activity and speed

Attributes provided

- PCIe x4, generation-1 or generation-2
- 4-Port machine access code (MAC)

- High performance IPV4/IPV6 checksum offload
- Supports large send and large receive
- Multiple queues
- VIOS

The following figure shows the adapter.

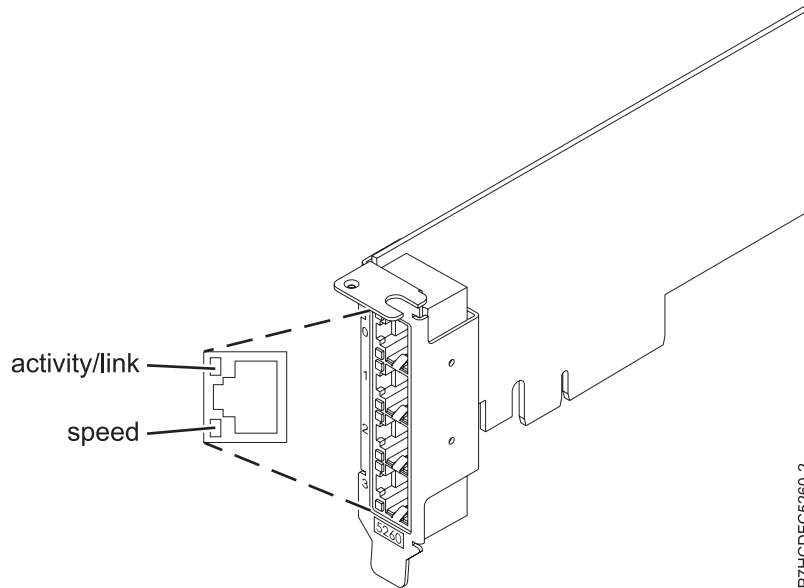

Figure 43. Adapter

Adapter LED states

The LEDs on the adapter provide information about the operation status of the adapter. The LEDs are visible through the mounting bracket. Figure 43 shows the location of the LEDs. Table 8 describes the different LED states and what those states indicate.

Table 8. Adapter LEDs and descriptions

LED	Light	Description
Speed	Yellow	10 Mbps or 100 Mbps
	Green	1000 Mbps or 1 Gbps
Activity/link	Green flashing	Active link or data activity
	Off	No link The absence of a link can indicate a defective cable, defective connector, or a configuration mismatch.

For details about slot priorities and placement rules, see PCIe adapter placement rules and slot priorities (http://www.ibm.com/support/knowledgecenter/POWER8/p8eab/p8eab_mtm_pciplacement.htm) and select the system you are working on.

Operating system or partition requirements

The adapter is supported on the following versions of the operating systems, depending on the system you are using:

- AIX

- AIX 7.1, Technology Level 3, Service Pack 2, or later
- AIX 6.1, Technology Level 8, Service Pack 3, or later
- AIX Version 5.3, Technology Level 12, or later
- Linux
 - Red Hat Enterprise Linux Version 7, or later, with current maintenance updates available from Red Hat.
 - Red Hat Enterprise Linux Version 6.4, or later, with current maintenance updates available from Red Hat.
 - SUSE Linux Enterprise Server Version 12, or later
 - SUSE Linux Enterprise Server 11, Service Pack 2, or later, with current maintenance updates available from SUSE.
 - Ubuntu Server 14.04.3, or later
 - For support details, see the Linux Alert website (www14.software.ibm.com/webapp/set2/sas/f/lopdiags/info/LinuxAlerts.html).
 - The latest version of the device driver or iprutils can be downloaded from the IBM Service and Productivity Tools website(<http://www14.software.ibm.com/webapp/set2/sas/f/lopdiags/home.html>).
- IBM i
 - IBM i Version 7.2 or later
 - IBM i Version 7.1, or later
- VIOS
 - VIOS support requires VIOS 2.2.1.4, or later.
- PowerKVM
 - IBM PowerKVM 2.1.1, or later

PCIe2 4-port 1 GbE Adapter (FC 5899; CCIN 576F)

Learn about the specifications and operating system requirements for the feature code (FC) 5899 adapter.

Overview

FC 5260 and FC 5899 are both the same adapter with different feature codes. FC 5260 is a low-profile adapter and the FC 5899 is a full-height adapter.

The PCIe2 4-port 1 GbE Adapter is a full-height, generation-2 PCIe adapter. This adapter provides four 1-Gb Ethernet ports that can be configured to run at 1000 megabits per second (Mbps) (or 1 gigabit per second (Gbps)), 100 Mbps, or 10 Mbps. The adapter connects to a network that uses unshielded twisted pair (UTP) cable for distances of up to 100 meters (328.08 feet). The adapter supports AIX Network Installation Management (NIM) boot capability. The adapter conforms to the IEEE 802.3ab 1000Base-T standard. The adapter supports jumbo frames when running at the 1000 Mbps speed.

Each of the Ethernet ports can be connected by using:

- CAT5e (or later) UTP cables for 1000 Mbps network attachment
- CAT5 or CAT3 UTP cables for 100 Mbps or 10 Mbps network attachment

The cables are attached to the copper RJ45 connectors. Each port is independent of one another and supports full-duplex or half-duplex. The half-duplex mode does not support a speed of 1000 Mbps.

The adapter provides the following features:

- Supports interrupt moderation to deliver increased performance while significantly reducing processor utilization
- Supports dual port operation in almost any PCIe slot, except x1

- Supports auto-negotiation, full-duplex only
- Supports integrated media-access control (MAC) and physical layer (PHY)
- Supports Fast EtherChannel (FEC) with the existing software
- Supports gigabit EtherChannel (GEC) with the existing software
- Supports IEEE 802.3ad (Link Aggregation control protocol)
- Supports IEEE 802.1Q VLANs
- Supports IEEE 802.3 z, ab, u, x flow control support
- Supports IEEE 802.1p
- Supports IEEE 802.3ab for TX
- Supports TCP checksum offload transmission control protocol (TCP), user datagram protocol (UDP), Internet Protocol (IP) for IPv4 and IPv6
- Supports TCP segmentation or large send offload
- Supports EEPROM-SPI and single EEPROM
- Supports interrupt levels INTA and MSI
- Hardware certifications FCC B, UL, CE, VCCI, BSMI, CTICK, MIC
- Network Controller (MAC) Intel 82571EB
- Compliant with European Union Directive 2002/95/EC on the Restriction of the Use of Certain Hazardous Substances in Electrical and Electronic Equipment

Specifications

Item Description

Adapter FRU number

74Y4064 (Designed to comply with RoHS requirement)

Wrap plug

10N7405

Note: Wrap plugs are not included with the card and cannot be purchased from IBM.

I/O bus architecture

PCIe2.0, x4

Slot requirement

One PCIe x4 slot.

Cables

4-pair, CAT5e, UTP cables are connected to copper RJ45 connectors.

Voltage

3.3 V

Form factor

Short, full-height

Maximum number

For details about the maximum number of adapters that are supported, see PCIe adapter placement rules and slot priorities (http://www.ibm.com/support/knowledgecenter/POWER8/p8eab/p8eab_mtm_pciplacement.htm) and select the system you are working on.

Connector information

- Two RJ-45 ports
- Two LED adapter status indicators per port, for link activity and speed

Attributes provided

- PCIe x4, generation-1 or generation-2
- 4-Port machine access code (MAC)
- High performance IPV4/IPV6 checksum offload
- Large Send and Large Receive Support
- Multiple Queues
- VIOS

The following figure shows the adapter.

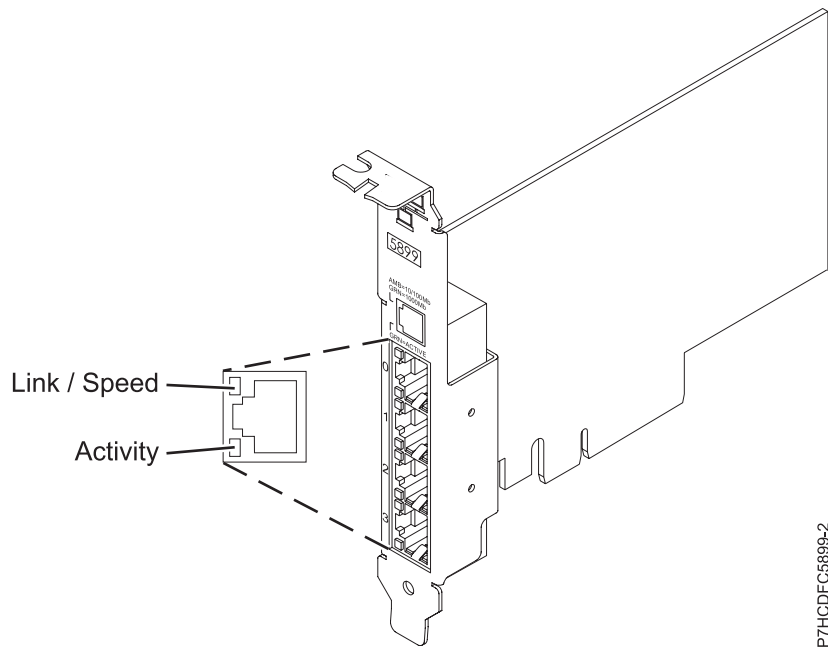

Figure 44. Adapter

Adapter LED states

The LEDs on the adapter provide information about the operation status of the adapter. The LEDs are visible through the mounting bracket. Figure 44 shows the location of the LEDs. Table 9 describes the different LED states and what those states indicate.

Table 9. Adapter LEDs and descriptions

LED	Light	Description
Link/Speed	Yellow	10 Mbps or 100 Mbps
	Green	1000 Mbps or 1 Gbps
Activity	Green flashing	Active link or data activity
	Off	No link The absence of a link can indicate a defective cable, defective connector, or a configuration mismatch.

Operating system or partition requirements

This adapter is supported for the following versions of operating systems:

- AIX
 - AIX Version 7.1 with the 7100-01 Technology Level and Service Pack 4, or later.
 - AIX Version 7.1 with the 7100-00 Technology Level and Service Pack 6, or later.
 - AIX Version 6.1 with the 6100-07 Technology Level, and Service Pack 4, or later.
 - AIX Version 6.1 with the 6100-06 Technology Level, and Service Pack 8, or later.
 - AIX Version 5.3 with the 5300-12 Technology Level and Service Pack 6, or later.
- Linux
 - Red Hat Enterprise Linux 6.2, or later.

- Red Hat Enterprise Linux 5.8, or later.
- SUSE Linux Enterprise Server 11, Service Pack 2, or later (with update package).
- For support details, see the Linux Alert website (www14.software.ibm.com/webapp/set2/sas/f/lopdiags/info/LinuxAlerts.html).
- IBM i
 - IBM i Version 7.2 or later
 - IBM i Version 7.1, or later
- VIOS
 - VIOS support requires VIOS 2.2.1.4, or later.

PCIe3 LP 2-Port 40 GbE NIC RoCE QSFP+ Adapter (FC EC3A; CCIN 57BD)

Learn about the specifications and operating system requirements for the feature code (FC) EC3A adapter.

Overview

The PCIe3 LP 2-Port 40 GbE NIC RoCE QSFP+ Adapter is a low-profile, PCIe generation-3 (PCIe3), dual port, 40-Gigabit Ethernet (GbE) adapter with a PCIe 3.0 host bus interface. The adapter acts as a network interface controller (NIC) and uses the IBTA RDMA over Converged Ethernet (RoCE) protocols to provide efficient Remote Direct Memory Access (RDMA) services. The adapter delivers high-bandwidth and low-latency 40 GbE connectivity, reducing the load on the processor and efficiently using the memory access. This action off-loads the processor from networking tasks which improves the performance and scalability of the processor.

The adapter is optimized for enterprise data centers, high-performance computing, transaction databases, cloud computing, virtualization, storage, and other embedded environments. The adapter improves network performance by increasing available bandwidth to the processor and by providing enhanced performance. The adapter provides dedicated adapter resources and protection for virtual machines (VM). The link aggregation and failover features of the adapter are ideal for critical network applications that require redundancy and high availability.

The two 40 Gb quad (4-channel) small form-factor pluggable (QSFP+) transceiver ports are used for connectivity with other servers or switches in the network. Each QSFP+ port provides Ethernet connectivity with a nominal data rate of 40 gigabits per second (Gbps).

The adapter does not include transceivers. Use copper cables with QSFP+ 40G BASE-SR transceivers for short distances. See “Cables” on page 45 for more information about the cables.

For details about slot priorities and placement rules, see PCIe adapter placement rules and slot priorities (http://www.ibm.com/support/knowledgecenter/POWER8/p8eab/p8eab_mtm_pciplacement.htm) and select the system you are working on.

The adapter provides the following features:

- Data center bridging support (IEEE standard version CEE)
- T11.3 FC-BB-5 FCoE
- TCP/IP stateless offload in hardware
- Traffic steering across multiple cores
- Intelligent interrupt coalescence
- Advanced Quality of Service (QoS)
- RoHS-R6 compliant
- RDMA over Ethernet using uDAPL

The adapter provides Ethernet NIC support with the following features:

- 64-bit kernel environments
- multi-processor safe
- AIX Common Data Link Interface (CDLI) compliant
- Concurrent operation of NIC and RoCE device drivers while sharing the same physical port
- Standard frames (1518 bytes + 4 bytes for VLAN tag)
- Jumbo frames (9018 bytes + 4 bytes for VLAN tag)
- IPV4 or IPV6 transmit/receive TCP checksum offload
- IPV4 transmit TCP segmentation offload (commonly known as large send)
- IPV4 receive TCP segmentation aggregation (commonly known as large receive)
- Enhanced Error Handling (EEH) from PCI bus errors

Figure 45 shows the adapter.

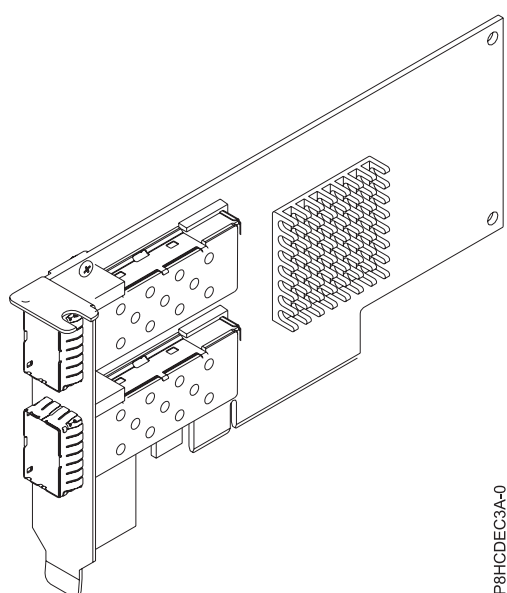

Figure 45. FC EC3A adapter

Specifications

Item Description

Adapter FRU number

00FW105 (Designed to comply with RoHS requirement)

I/O bus architecture

PCIe3 x8

Slot requirement

For details about slot priorities and placement rules, see PCIe adapter placement rules and slot priorities (http://www.ibm.com/support/knowledgecenter/POWER8/p8eab/p8eab_mtm_pciplacement.htm) and select the system you are working on.

Cables

See “Cables” on page 45 for details.

Voltage

3.3 V

Form factor

Short

Maximum number

For details about the maximum number of adapters that are supported, see PCIe adapter

placement rules and slot priorities (http://www.ibm.com/support/knowledgecenter/POWER8/p8eab/p8eab_mtm_pciplacement.htm) and select the system you are working on.

Cables

This adapter feature requires the use of compatible QSFP+, 40 Gbps, copper, twinaxial, active, Ethernet cables for cabling over short distances. See Figure 46 for different views of the QSFP+ copper cable. For distances over 5 meters, use two optical QSFP+ SR transceivers (FC EB27) that attach to optical cables FC EB2J or FC EB2K. See Table 10 for details about the feature codes.

Do not mix copper and optical cables on the same adapter.

These cables are compliant with industry standard specifications SFF-8431 Rev 4.1 and SFF-8472 Rev 10.4, and all applicable IBM requirements.

Note: These cables are EMC Class A compliant.

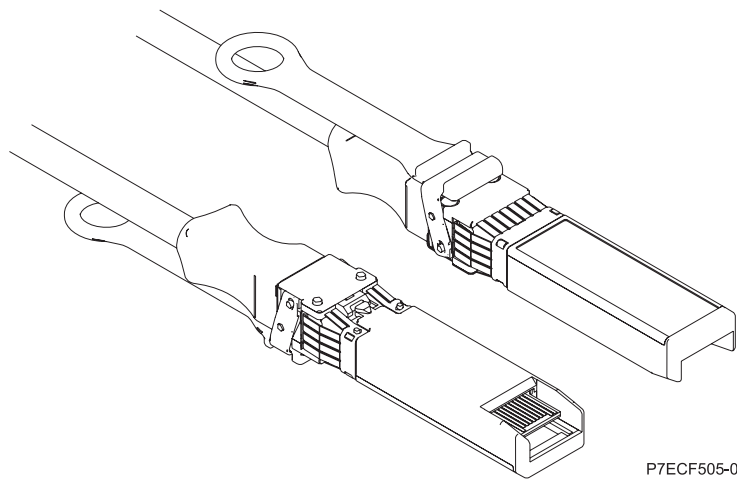

Figure 46. Top and bottom view of the cable

Table 10. Feature code and part number for varying lengths of the cable

Cable length	Feature code	CCIN	Part number
Copper cables			
1 m (3.28 ft)	EB2B		49Y7934
3 m (9.84 ft)	EB2H		49Y7935
5 m (16.4 ft)	ECBN		00D5809
Optical cables			
10 m (32.8 ft)	EB2J		41V2458
30 m (98.4 ft)	EB2K		45D6369
QSFP+ 40G BASE-SR transceiver	EB27		49Y7928

Operating system or partition requirements

If you are installing a new feature, ensure that you have the software that is required to support the new feature and that you determine whether any prerequisites must be met for this feature and attaching devices. To check for the prerequisites, see IBM Prerequisite website (www-912.ibm.com/e_dir/eServerPrereq.nsf).

The adapter is supported on the following versions of the operating systems, depending on the system you are using:

- AIX
 - AIX 7.1, or later
 - AIX Version 6.1, or later
- Linux
 - Red Hat Enterprise Linux Version 7, or later, with current maintenance updates available from Red Hat.
 - Red Hat Enterprise Linux Version 6.5, or later, with current maintenance updates available from Red Hat.
 - SUSE Linux Enterprise Server Version 12, or later
 - SUSE Linux Enterprise Server 11, Service Pack 3, or later, with current maintenance updates available from SUSE.
 - Ubuntu Server 14.04.3, or later
 - For support details, see the Linux Alert website (www14.software.ibm.com/webapp/set2/sas/f/lopdiags/info/LinuxAlerts.html).
 - The latest version of the device driver or `iprutils` can be downloaded from the IBM Service and Productivity Tools website (<http://www14.software.ibm.com/webapp/set2/sas/f/lopdiags/home.html>).
- Supported on Firmware level 8.1
- PowerKVM
 - IBM PowerKVM 2.1.1, or later

PCIe3 2-Port 40 GbE NIC RoCE QSFP+ Adapter (FC EC3B; CCIN 57BD)

Learn about the specifications and operating system requirements for the feature code (FC) EC3B adapter.

Overview

The PCIe3 2-Port 40 GbE NIC RoCE QSFP+ Adapter is a regular-height, PCIe generation-3 (PCIe3), dual port, 40-Gigabit Ethernet (GbE) adapter with a PCIe 3.0 host bus interface. The adapter acts as a network interface controller (NIC) and uses the IBTA RDMA over Converged Ethernet (RoCE) protocols to provide efficient Remote Direct Memory Access (RDMA) services. The adapter delivers high-bandwidth and low-latency 40 GbE connectivity, reducing the load on the processor and efficiently using the memory access. This action off-loads the processor from networking tasks which improves the performance and scalability of the processor.

The adapter is optimized for enterprise data centers, high-performance computing, transaction databases, cloud computing, virtualization, storage, and other embedded environments. The adapter improves network performance by increasing available bandwidth to the processor and by providing enhanced performance. The adapter provides dedicated adapter resources and protection for virtual machines (VM). The link aggregation and failover features of the adapter are ideal for critical network applications that require redundancy and high availability.

The two 40 Gb quad (4-channel) small form-factor pluggable (QSFP+) transceiver ports are used for connectivity with other servers or switches in the network. Each QSFP+ port provides Ethernet connectivity with a nominal data rate of 40 gigabits per second (Gbps).

The adapter does not include transceivers. Use copper cables with QSFP+ 40G BASE-SR transceivers for short distances. See “Cables” on page 48 for more information about the cables.

For details about slot priorities and placement rules, see PCIe adapter placement rules and slot priorities (http://www.ibm.com/support/knowledgecenter/POWER8/p8eab/p8eab_mtm_pciplacement.htm) and select the system you are working on.

The adapter provides the following features:

- Data center bridging support (IEEE standard version CEE)
- T11.3 FC-BB-5 FCoE
- TCP/IP stateless offload in hardware
- Traffic steering across multiple cores
- Intelligent interrupt coalescence
- Advanced Quality of Service (QoS)
- RoHS-R6 compliant
- RDMA over Ethernet using uDAPL

The adapter provides Ethernet NIC support with the following features:

- 64-bit kernel environments
- multi-processor safe
- AIX Common Data Link Interface (CDLI) compliant
- Concurrent operation of NIC and RoCE device drivers while sharing the same physical port
- Standard frames (1518 bytes + 4 bytes for VLAN tag)
- Jumbo frames (9018 bytes + 4 bytes for VLAN tag)
- IPV4 or IPV6 transmit/receive TCP checksum offload
- IPV4 transmit TCP segmentation offload (commonly known as large send)
- IPV4 receive TCP segmentation aggregation (commonly known as large receive)
- Enhanced Error Handling (EEH) from PCI bus errors

Figure 47 on page 48 shows the adapter.

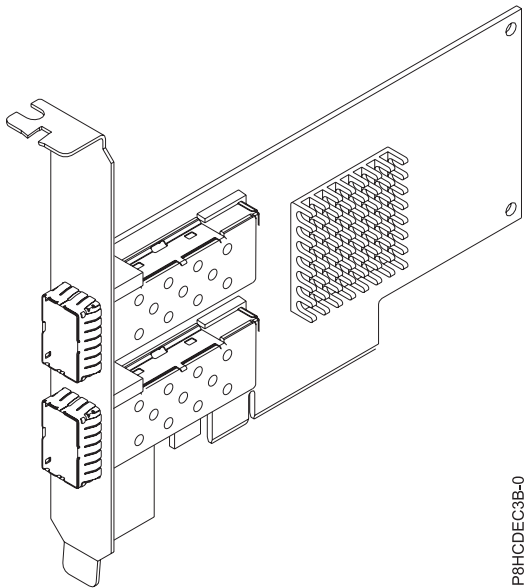

Figure 47. FC EC3B adapter

Specifications

Item Description

Adapter FRU number

00FW105 (Designed to comply with RoHS requirement)

I/O bus architecture

PCIe3 x8

Slot requirement

For details about slot priorities and placement rules, see PCIe adapter placement rules and slot priorities (http://www.ibm.com/support/knowledgecenter/POWER8/p8eab/p8eab_mtm_pciplacement.htm) and select the system you are working on.

Cables

See “Cables” for details.

Voltage

3.3 V

Form factor

Short

Maximum number

For details about the maximum number of adapters that are supported, see PCIe adapter placement rules and slot priorities (http://www.ibm.com/support/knowledgecenter/POWER8/p8eab/p8eab_mtm_pciplacement.htm) and select the system you are working on.

Cables

This adapter feature requires the use of compatible QSFP+, 40 Gbps, copper, twinaxial, active, Ethernet cables for cabling over short distances. See Figure 48 on page 49 for different views of the QSFP+ copper cable. For distances over 5 meters, use two optical QSFP+ SR transceivers (FC EB27) that attach to optical cables FC EB2J or FC EB2K. See Table 11 on page 49 for details about the feature codes.

Do not mix copper and optical cables on the same adapter.

These cables are compliant with industry standard specifications SFF-8431 Rev 4.1 and SFF-8472 Rev 10.4, and all applicable IBM requirements.

Note: These cables are EMC Class A compliant.

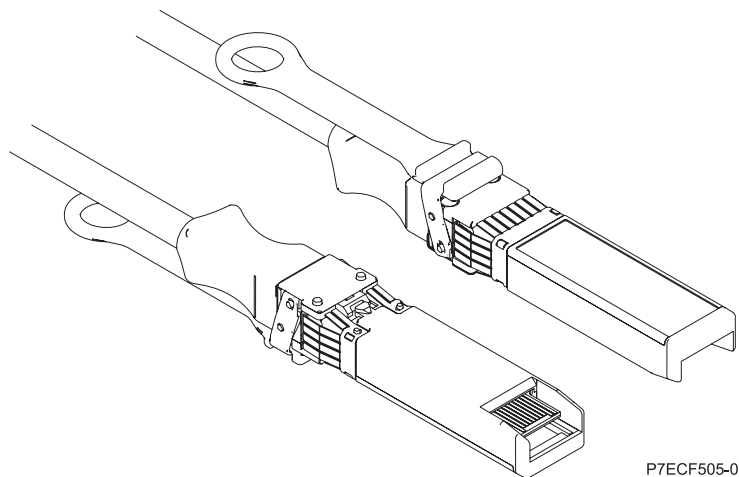

Figure 48. Top and bottom view of the cable

Table 11. Feature code and part number for varying lengths of the cable

Cable length	Feature code	CCIN	Part number
Copper cables			
1 m (3.28 ft)	EB2B		49Y7934
3 m (9.84 ft)	EB2H		49Y7935
5 m (16.4 ft)	ECBN		00D5809
Optical cables			
10 m (32.8 ft)	EB2J		41V2458
30 m (98.4 ft)	EB2K		45D6369
QSFP+ 40G BASE-SR transceiver	EB27		49Y7928

Operating system or partition requirements

If you are installing a new feature, ensure that you have the software that is required to support the new feature and that you determine whether any prerequisites must be met for this feature and attaching devices. To check for the prerequisites, see IBM Prerequisite website (www-912.ibm.com/e_dir/eServerPrereq.nsf).

The adapter is supported on the following versions of the operating systems, depending on the system you are using:

- AIX
 - AIX 7.1, or later
 - AIX Version 6.1, or later
- Linux
 - Red Hat Enterprise Linux Version 6.5, or later, with current maintenance updates available from Red Hat.
 - SUSE Linux Enterprise Server 11, Service Pack 3, or later, with current maintenance updates available from SUSE.
 - For support details, see the Linux Alert website (www14.software.ibm.com/webapp/set2/sas/f/lopdiags/info/LinuxAlerts.html).

- The latest version of the device driver or iprutils can be downloaded from the IBM Service and Productivity Tools website(<http://www14.software.ibm.com/webapp/set2/sas/f/lopdiags/home.html>).
- Supported on Firmware level 8.1

PCIe3 LP 2-port 100 Gb EDR InfiniBand Adapter (FC EC3E and EC3F; CCIN 2CEA)

Learn about the specifications and operating system requirements for the feature code (FC) EC3E adapter.

Overview

FC EC3E and EC3F are both the same adapter with different feature codes. FC EC3E is a low-profile adapter and FC EC3F is a full-height adapter.

The PCIe3 2-port 100 Gb enhanced data rate (EDR) InfiniBand adapter provides high-speed connectivity with other servers or InfiniBand switches. Each port maximum of 100 Gb assumes that no other system and or switch bottlenecks are present.

Note:

- The ambient environment must be less than or equal to 25°C (Celsius) and 500 M (meters) when using 12x LFF (large form factor) HDDs (hard disk drives) in the 8348-21C.
- For no ambient restrictions in the 8348-21C, keep at least two of three bays empty of LFF HDDs in the leftmost drive column.

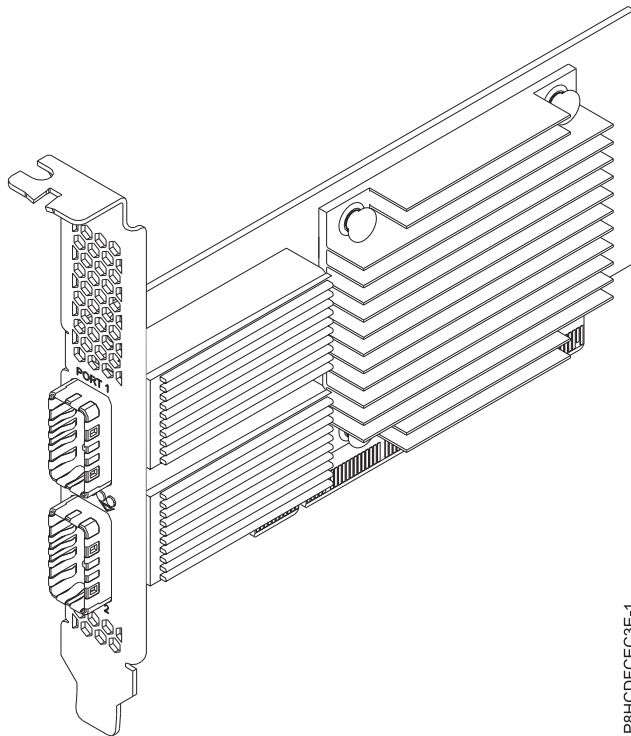

Figure 49. PCIe Gen3 low profile x16 2-port EDR InfiniBand adapter

Specifications

Item	Description
Adapter FRU number	00WT075 (Designed to comply with RoHS requirement.)

I/O bus architecture

PCIe x16

Slot requirement

For details about slot priorities and placement rules, see PCIe adapter placement rules and slot priorities (http://www.ibm.com/support/knowledgecenter/POWER8/p8eab/p8eab_mtm_pciplacement.htm) and select the system you are working on.

Cables

The two 100 Gb ports have QSFP28 connections. These 100 Gb ports support industry standard EDR DAC or optical cables.

Note: One adapter supports both types of cable. You can choose to cable just one port.

Voltage

3.3 V

Form factor

Short, low-profile (FC EC3E)

Short, will full-height tailstock (FC EC3F)

Maximum number

For details about the maximum number of adapters that are supported, see PCIe adapter placement rules and slot priorities (http://www.ibm.com/support/knowledgecenter/POWER8/p8eab/p8eab_mtm_pciplacement.htm) and select the system you are working on.

Operating system or partition requirements

The adapter is supported on the following versions of the operating systems, depending on the system you are using:

- Linux:
 - Red Hat Enterprise Linux 7.2, little endian, or later, with Mellanox OFED 3.1, or later
 - Ubuntu Server 16.04, or later with Mellanox OFED 3.3, or later
 - Ubuntu Server 14.04.3, or later with Mellanox OFED 3.3, or later

PCIe3 LP 1-port 100 Gb EDR InfiniBand adapter x16 (FC EC3T and EC3U; CCIN 2CEB)

Learn about the specifications and operating system requirements for the feature code (FC) EC3T adapter.

Overview

FC EC3T and EC3U are both the same adapter with different feature codes. FC EC3T is a low-profile adapter and FC EC3U is a full-height adapter.

The PCIe Gen3 low profile x16 1-port EDR InfiniBand adapter provides high-speed connectivity with other servers or InfiniBand switches. A maximum of 100 G assumes that no other system and or switch bottlenecks are present. The x16 adapter allows full bandwidth in a PCIe Gen3 slot.

Note:

- The ambient environment must be less than or equal to 25°C (Celsius) and 500 M (meters) when using 12x LFF (large form factor) HDDs (hard disk drives) in the 8348-21C.
- For no ambient restrictions in the 8348-21C, keep at least two of three bays empty of LFF HDDs in the leftmost drive column.

The 100 Gb port has QSFP28 connection which supports industry standard EDR cables, either EDR DAC cables or EDR optical cables. One adapter can support either or both types of cable. You can choose to cable just one port if wanted.

Figure 50 on page 52 shows the adapter.

For details about slot priorities and placement rules, see PCIe adapter placement rules and slot priorities (http://www.ibm.com/support/knowledgecenter/POWER8/p8eab/p8eab_mtm_pciplacement.htm) and select the system you are working on.

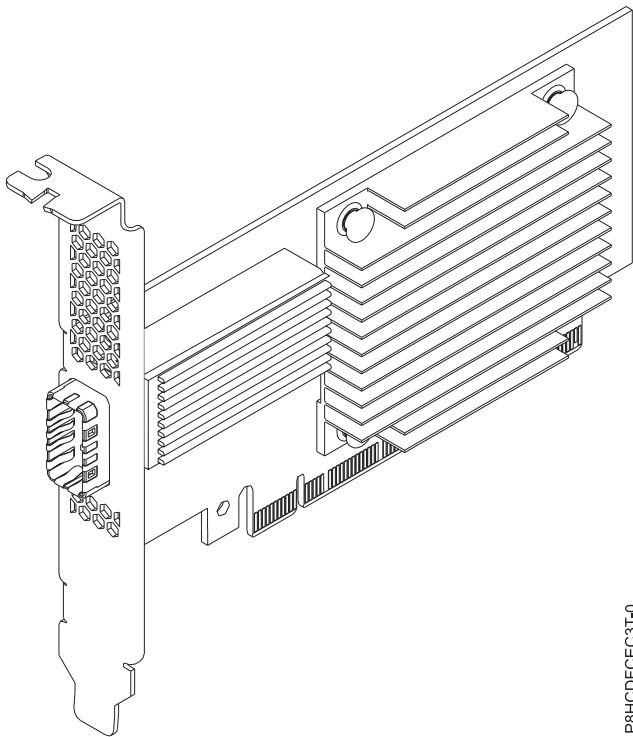

Figure 50. PCIe Gen3 low profile x16 1-port EDR InfiniBand adapter

Specifications

Item Description

Adapter FRU number

00WT013 (Designed to comply with RoHS requirement)

I/O bus architecture

PCIe3 x16

Slot requirement

For details about slot priorities and placement rules, see PCIe adapter placement rules and slot priorities (http://www.ibm.com/support/knowledgecenter/POWER8/p8eab/p8eab_mtm_pciplacement.htm) and select the system you are working on.

Cables

No cables required.

Voltage

3.3 V

Form factor

Short, low profile (FC EC3T)

Short, with full-height tail stock (FC EC3U)

Maximum number

For details about the maximum number of adapters that are supported, see PCIe adapter placement rules and slot priorities (http://www.ibm.com/support/knowledgecenter/POWER8/p8eab/p8eab_mtm_pciplacement.htm) and select the system you are working on.

Operating system or partition requirements

The adapter is supported on the following versions of the operating systems, depending on the system you are using:

- Linux:
 - Red Hat Enterprise Linux Version 7.2, with Mellanox Open Fabric Enterprise Distribution (OFED) 3.1.x, or later

PCIe Gen3 x16 GPU Adapter (FC EC49; CCIN 2CE9)

Learn about the specifications and operating system requirements for the feature code (FC) EC49 adapter.

Overview

The PCIe Gen3 x16 GPU Adapter is a double-wide, full-height, PCI express (PCIe) generation 3 (Gen3) graphics processing unit, compute intensive accelerator adapter. The adapter offers 12 GB of on-board memory and is optimized for compute-intensive applications. The adapter uses power from the PCIe connector and auxiliary power source from the system it is placed in. For a graphic of the adapter, see Figure 51

Important: Graphics processing units (GPUs) and cryptographic application programming interface (CAPI) adapters cannot be replaced with the power on.

For details about slot priorities and placement rules, see PCIe adapter placement rules and slot priorities (http://www.ibm.com/support/knowledgecenter/POWER8/p8eab/p8eab_mtm_pciplacement.htm) and select the system you are working on.

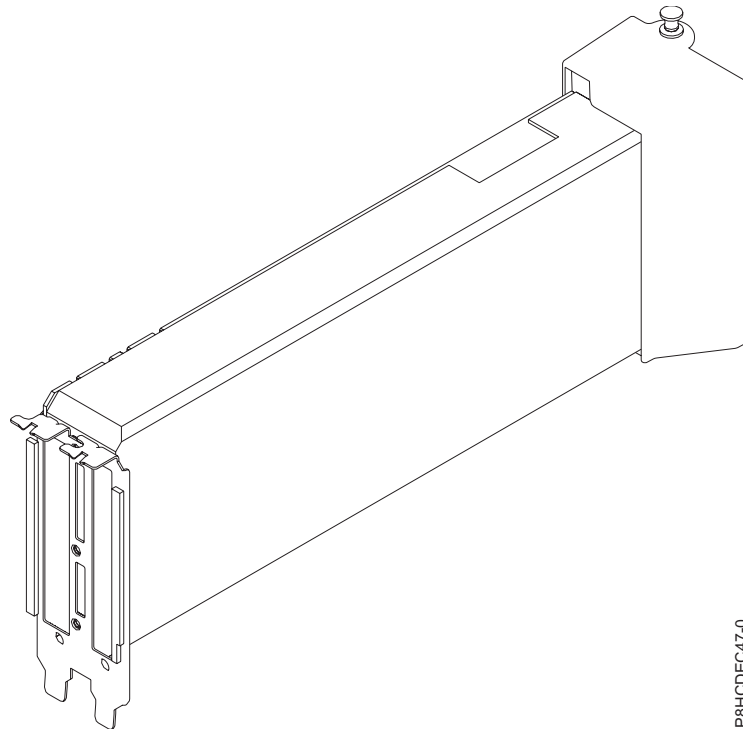

P8HCDEC47-0

Figure 51. PCIe Gen3 x16 GPU Adapter

Specifications

Item	Description
------	-------------

Adapter FRU number

00E4485 - S822LC GPU assembly (includes carrier assembly with cable and shield) (Designed to comply with RoHS requirement)

I/O bus architecture

PCIe3 x16

Slot requirement

For details about slot priorities and placement rules, see PCIe adapter placement rules and slot priorities (http://www.ibm.com/support/knowledgecenter/POWER8/p8eab/p8eab_mtm_pciplacement.htm) and select the system you are working on.

Cables

Auxiliary power cable part number 00RR917 connects from the 8-pin cable connector on the PCIe Gen3 x16 GPU Adapter to the power distribution board connector on the system backplane.

Voltage

12 V

Form factor

Full-height, full-length

Maximum number

For details about the maximum number of adapters that are supported, see PCIe adapter placement rules and slot priorities (http://www.ibm.com/support/knowledgecenter/POWER8/p8eab/p8eab_mtm_pciplacement.htm) and select the system you are working on.

Operating system or partition requirements

If you are installing a new feature, ensure that you have the software that is required to support the new feature and that you determine whether any prerequisites must be met for this feature and attaching devices. To check for the prerequisites, see IBM Prerequisite website (www-912.ibm.com/e_dir/eServerPrereq.nsf).

The adapter is supported on the following versions of the operating system, depending on the system you are using:

- Linux
 - Red Hat Enterprise Linux Version 7.2, little endian, for Power, or later
 - Ubuntu Server 14.04.3, or later
 - For support details, see the Linux Alert website (www14.software.ibm.com/webapp/set2/sas/f/lopdiags/info/LinuxAlerts.html).
 - The latest version of the device driver or iprutils can be downloaded from the IBM Service and Productivity Tools website(<http://www14.software.ibm.com/webapp/set2/sas/f/lopdiags/home.html>).

CAPI Compression Accelerator Adapter (FC EJ1A and EJ1B; CCIN 2CF0)

Learn about the specifications and operating system requirements for feature code (FC) EJ1A and EJ1B adapters.

Overview

FC EJ1A and EJ1B are both the same adapter with different feature codes. FC EJ1A is a full-height adapter and FC EJ1B is a low-profile adapter. See “PCIe3 FPGA Compression Accelerator Adapter (FC EJ12; CCIN 59AB)” on page 57 and “PCIe3 FPGA Compression Accelerator Adapter (FC EJ13; CCIN 59AB)” on page 59 for additional compression accelerator adapters.

The PCIe3 CAPI Compression Accelerator Adapter is a PCI Express (PCIe) generation 3 (Gen3) x8 adapter. The adapter can be used in either a x8 or x16 PCIe3 slot in the system. The CAPI Compression Accelerator Adapter implements the well-defined, open standard DEFLATE compressed data format. This data format is widely accepted through zlib, gzip, Java, and other applications. Within the gzip and zip file formats, the adapter is the standard for compressed data exchange. The adapter's high compression

bandwidth reduces the latency for a single compression job significantly. Its aggregate throughput allows the adapter to keep pace with common I/O traffic and offers reduced data for storage and network traffic. Additionally, the adapter has no impact on most I/O traffic and in some cases will have a positive effect. The adapter also enables good standard compression in cases where software overhead prevents it. To achieve the best performance gain, strive for data block sizes larger than 64 KB, or combine smaller blocks before sending them to hardware. The accelerated zlib library has a selectable buffering feature built-in as well. For a graphic of the full-height adapter, see Figure 52 on page 56

Important: Graphics processing units (GPUs) and Coherent Accelerator Processor Interface (CAPI) adapters cannot be replaced with the power on.

The following are examples of typical applications that can benefit from compression acceleration:

- Store or transmit large amounts of data that average over 100 MB/s
- Applications that need a high average throughput of data compressed
- Handling high peak throughput of data when software compression is limited
- When low latency for individual compression streams is required and it is more difficult to run in parallel on many CPUs
- When the standard DEFLATE compression format is required for interchange as used in gzip, zlib, zip, or JAR (Software compression methods such as LZ4 or LZS with lower compression ratios and high bandwidth on CPUs are not an option in that case)
- Compression or a mix of compression and decompression is the main bottleneck (Decompression alone can sometimes still be done in software with many cores in parallel)

Note: The adapter supports full speed decompression for all compliant compressed input regardless of whether it was compressed by hardware or software.

For details about slot priorities and placement rules, see PCIe adapter placement rules and slot priorities (http://www.ibm.com/support/knowledgecenter/POWER8/p8eab/p8eab_mtm_pciplacement.htm) and select the system you are working on.

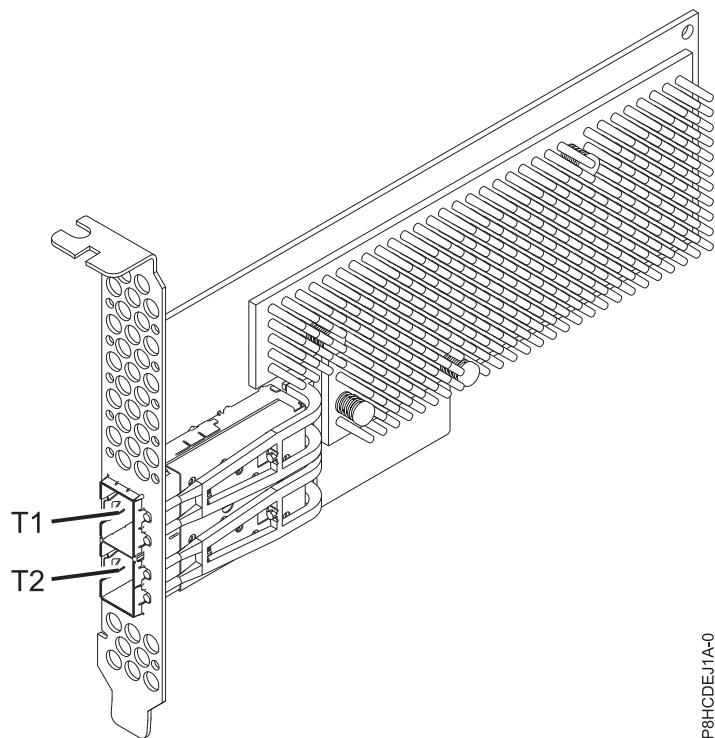

Figure 52. CAPI Compression Accelerator Adapter (Full-height)

Specifications

Item Description

Adapter FRU number

00WT173 (Designed to comply with RoHS requirement)

I/O bus architecture

PCIe3 x8

Slot requirement

One PCIe x8 or x16 CAPI enabled slot per adapter

Supported Systems

POWER8[®] processor-based server

- 8247-21L, 8247-22L, and 8247-42L
- 8335-GCA and 8335-GTA
- 8348-21C

Voltage

12 V

Form factor

Short, with full-height tailstock (FC EJ1A)

Short, low-profile (FC EJ1B)

Maximum number

For details about the maximum number of adapters that are supported, see PCIe adapter placement rules and slot priorities (http://www.ibm.com/support/knowledgecenter/POWER8/p8eab/p8eab_mtm_pciplacement.htm) and select the system you are working on.

Attributes provided

High throughput compression that saves storage and I/O bandwidth with little or no overhead

CPU offload and CAPI interface with negligible software load frees up CPU cores for higher value computation or licensed software

Lower power consumption by offloading the CPU intensive compression to an FPGA

Widely used zlib and gzip standard format for data interchange

Up to 2 GB/s compression and decompression throughput

4-30x speed up achievable

Compression ratio near software zlib and gzip

Multiple uses including genomics, data center, cloud, and backup solutions

Operating system or partition requirements

If you are installing a new feature, ensure that you have the software that is required to support the new feature and that you determine whether any prerequisites must be met for this feature and attaching devices. To check for the prerequisites, see IBM Prerequisite website (www-912.ibm.com/e_dir/eServerPrereq.nsf).

The adapter is supported on the following versions of the operating systems:

- Linux
 - Red Hat Enterprise Linux 7.2 LE, or later
 - Ubuntu 14.04.5, or later
 - For support details, see the Linux Alert website (www14.software.ibm.com/webapp/set2/sas/f/lopdiags/info/LinuxAlerts.html).
 - For additional information regarding firmware level and additional software installations, see Fix Central.
 - See the specific firmware level for 8335-GCA and GTA at Fix Central (8335-GCA and GTA).
 - See the specific firmware level for 8348-21C at Fix Central (8348-21C).
 - To use the CAPI Compression Accelerator Adapter, the following software packages must be downloaded at the IBM Service and Productivity Tools website (<http://www14.software.ibm.com/webapp/set2/sas/f/lopdiags/home.html>):
 - genwqe-zlib: Hardware accelerated zlib
 - genwqe-tools: Tools to analyze adapter functionality plus hardware accelerated genwqe_gzip and genwqe_gunzip
 - For details on how the adapter can be used to accelerate your application, please refer to the CAPI Compression Accelerator Adapter user's guide published on IBM developerWorks (<http://www.ibm.com/developerworks/>).

PCIe3 FPGA Compression Accelerator Adapter (FC EJ12; CCIN 59AB)

Learn about the specifications and operating system requirements for the feature code (FC) EJ12 adapter.

Overview

FC EJ12 and EJ13 are both the same adapter with different feature codes. FC EJ12 is a full-height adapter and FC EJ13 is a low-profile adapter. See “CAPI Compression Accelerator Adapter (FC EJ1A and EJ1B; CCIN 2CF0)” on page 54 for compression accelerator adapters with greater compression acceleration and CPU load reduction.

The PCIe3 FPGA Compression Adapter is a PCI Express (PCIe) generation 3 (Gen3), x8 adapter. The adapter can be used in either a x8 or x16 PCIe Gen3 slot in the system. The PCIe3 FPGA Compression Accelerator Adapter implements the well-defined, open standard DEFLATE compressed data format. This data format is widely accepted through zlib, gzip, Java and other applications. Within the gzip and zip file formats, the adapter is the standard for compressed data exchange. The adapter's high compression bandwidth reduces the latency for a single compression job significantly. Its aggregate throughput allows the adapter to keep pace with common I/O traffic and offers reduced data for storage and network

traffic. Additionally, the adapter has no impact on most I/O traffic and in some cases will have a positive effect. The adapter also enables good standard compression in cases where software overhead prevents it.

The following are examples of typical applications that can benefit from compression acceleration:

- Store or transmit large amounts of data that average over 100 MB/s
- Expensive storage with high storage bandwidth, where the accelerator's compression ratio, compared to fast software compression, yields significant savings
- Applications that need a high average throughput of data compressed
- Handling high peak throughput of data when software compression is limited
- When low latency for individual compression streams is required and it is more difficult to run in parallel on many CPUs
- When the standard DEFLATE compression format is required for interchange as used in gzip, zlib, zip, or JAR (Software compression methods such as LZ4 or LZS with lower compression ratios and high bandwidth on CPUs are not an option in that case)
- Compression or a mix of compression and decompression is the main bottleneck.

Note: Decompression alone can sometimes still be done in software with many cores in parallel. The adapter supports full speed decompression for all compliant compressed input regardless of whether it was compressed by hardware or software.

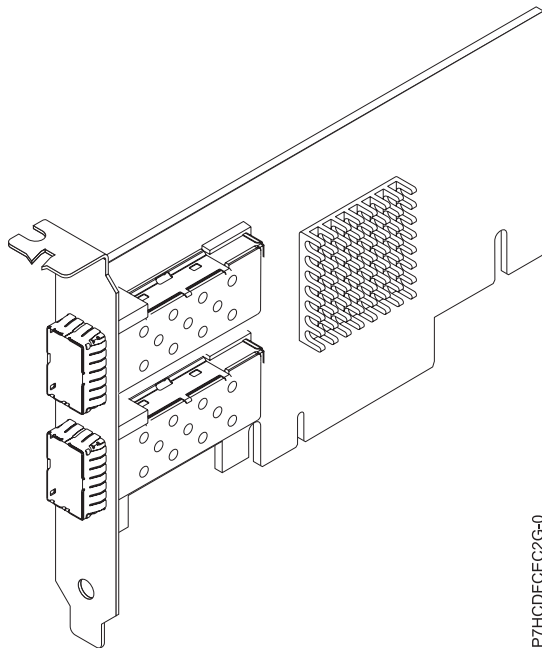

Figure 53. PCIe3 FPGA Compression Accelerator Adapter

Specifications

Item	Description
Adapter FRU number	000NK006 (Designed to comply with RoHS requirement)
I/O bus architecture	PCIe3 x8
Slot requirement	One PCIe x8 or x16 slot

Voltage

3.3 V, 12 V

Form factor

Full-height (FC EJ12) and short, low-profile (FC EJ13)

Maximum number

For details about the maximum number of adapters that are supported, see PCIe adapter placement rules and slot priorities (http://www.ibm.com/support/knowledgecenter/POWER8/p8eab/p8eab_mtm_pciplacement.htm) and select the system you are working on.

Attributes provided

High throughput compression that saves storage and I/O bandwidth with little or no overhead CPU offload and PCIe interface with negligible software load frees up CPU cores for higher value computation or licensed software

Lower power consumption by offloading the CPU intensive compression to an FPGA

Widely used zlib and gzip standard format for data interchange

Up to 1.8 GB/s compression and decompression throughput

3-25x speed up achievable

Compression ratio near software zlib and gzip

Multiple uses including genomics, data center, cloud, and backup solutions

Operating system or partition requirements

The adapter is supported on the following versions of the operating systems, depending on the system you are using:

- AIX
 - AIX 7.1, Technology Level 3, Service Pack 2, or later
 - AIX 6.1, Technology Level 9, or later
- Linux
 - Red Hat Enterprise Linux 7.2, and later include the GenWQE Linux drive
 - Red Hat Enterprise Linux 7.1, or later

Important: See Generic Work Queue Engine (GenWQE) introduction for instructions about installing the driver.

- Red Hat Enterprise Linux 7, or later
- For support details, see the Linux Alert website (www14.software.ibm.com/webapp/set2/sas/f/lopdiags/info/LinuxAlerts.html).
- For additional information regarding firmware level and additional software installations, see Fix Central.
- To use the PCIe3 FPGA Compression Accelerator Adapter, the following software packages must be downloaded at the IBM Service and Productivity Tools website (<http://www14.software.ibm.com/webapp/set2/sas/f/lopdiags/home.html>):
 - genwqe-zlib: Hardware accelerated zlib
 - genwqe-tools: Tools to analyze adapter functionality plus hardware accelerated genwqe_gzip and genwqe_gunzip
- For details on how the adapter can be used to accelerate your application, please refer to the Generic Work Queue Engine (GenWQE) Application Programming Guide published on IBM developerWorks (<http://www.ibm.com/developerworks/>).

PCIe3 FPGA Compression Accelerator Adapter (FC EJ13; CCIN 59AB)

Learn about the specifications and operating system requirements for the feature code (FC) EJ13 adapter.

Overview

FC EJ12 and EJ13 are both the same adapter with different feature codes. FC EJ12 is a full-height adapter and FC EJ13 is a low-profile adapter. See “CAPI Compression Accelerator Adapter (FC EJ1A and EJ1B; CCIN 2CF0)” on page 54 for compression accelerator adapters with greater compression acceleration and CPU load reduction.

The PCIe3 FPGA Compression Adapter is a PCI Express (PCIe) generation 3 (Gen3), x8 adapter. The adapter can be used in either a x8 or x16 PCIe Gen3 slot in the system. The PCIe3 FPGA Compression Accelerator Adapter implements the well-defined, open standard DEFLATE compressed data format. This data format is widely accepted through zlib, gzip, Java and other applications. Within the gzip and zip file formats, the adapter is the standard for compressed data exchange. The adapter's high compression bandwidth reduces the latency for a single compression job significantly. Its aggregate throughput allows the adapter to keep pace with common I/O traffic and offers reduced data for storage and network traffic. Additionally, the adapter has no impact on most I/O traffic and in some cases will have a positive effect. The adapter also enables good standard compression in cases where software overhead prevents it.

The following are examples of typical applications that can benefit from compression acceleration:

- Store or transmit large amounts of data that average over 100 MB/s
- Expensive storage with high storage bandwidth, where the accelerator's compression ratio, compared to fast software compression, yields significant savings
- Applications that need a high average throughput of data compressed
- Handling high peak throughput of data when software compression is limited
- When low latency for individual compression streams is required and it is more difficult to run in parallel on many CPUs
- When the standard DEFLATE compression format is required for interchange as used in gzip, zlib, zip, or JAR (Software compression methods such as LZ4 or LZS with lower compression ratios and high bandwidth on CPUs are not an option in that case)
- Compression or a mix of compression and decompression is the main bottleneck.

Note: Decompression alone can sometimes still be done in software with many cores in parallel. The adapter supports full speed decompression for all compliant compressed input regardless of whether it was compressed by hardware or software.

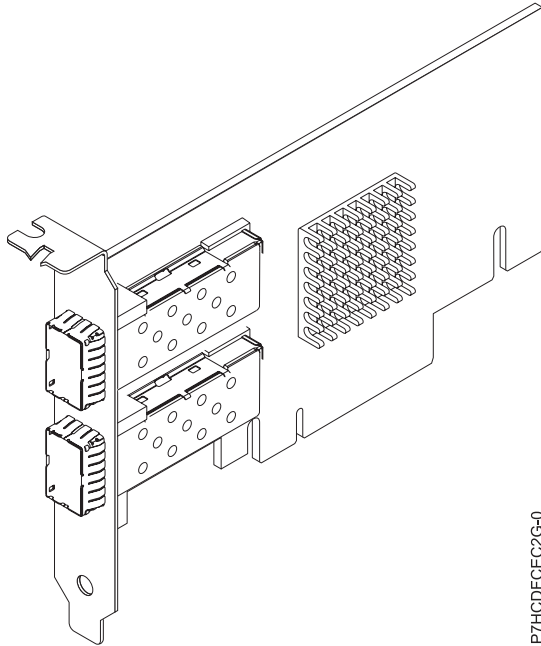

Figure 54. PCIe3 FPGA Compression Accelerator Adapter

Specifications

Item Description

Adapter FRU number

000NK006 (Designed to comply with RoHS requirement)

I/O bus architecture

PCIe3 x8

Slot requirement

One PCIe x8 or x16 slot (Low-profile)

Voltage

3.3 V, 12 V

Form factor

Full-height (FC EJ12) and short, low-profile (FC EJ13)

Maximum number

For details about the maximum number of adapters that are supported, see PCIe adapter placement rules and slot priorities (http://www.ibm.com/support/knowledgecenter/POWER8/p8eab/p8eab_mtm_pciplacement.htm) and select the system you are working on.

Attributes provided

High throughput compression that saves storage and I/O bandwidth with little or no overhead

CPU offload and PCIe interface with negligible software load frees up CPU cores for higher value computation or licensed software

Lower power consumption by offloading the CPU intensive compression to an FPGA

Widely used zlib and gzip standard format for data interchange

Up to 1.8 GB/s compression and decompression throughput

3-25x speed up achievable

Compression ratio near software zlib and gzip

Multiple uses including genomics, data center, cloud, and backup solutions

Operating system or partition requirements

The adapter is supported on the following versions of the operating systems, depending on the system you are using:

- AIX
 - AIX 7.1, Technology Level 3, Service Pack 2, or later
 - AIX 6.1, Technology Level 9, or later
- Linux
 - Red Hat Enterprise Linux 7.2, and later include the GenWQE Linux drive
 - Red Hat Enterprise Linux 7.1, or later

Important: See Generic Work Queue Engine (GenWQE) introduction (<https://www.ibm.com/support/knowledgecenter/linuxonibm/liabt/liabtkickoff.htm>) on how to install the driver.

- Red Hat Enterprise Linux 7, or later
- For support details, see the Linux Alert website (www14.software.ibm.com/webapp/set2/sas/f/lopdiags/info/LinuxAlerts.html).
- For additional information regarding firmware level and additional software installations, see Fix Central (<http://www.ibm.com/support/fixcentral/>).
- To use the PCIe3 FPGA Compression Accelerator Adapter, the following software packages must be downloaded at the IBM Service and Productivity Tools website (<http://www14.software.ibm.com/webapp/set2/sas/f/lopdiags/home.html>):
 - genwqe-zlib: Hardware accelerated zlib
 - genwqe-tools: Tools to analyze adapter functionality plus hardware accelerated genwqe_gzip and genwqe_gunzip
- For details on how the adapter can be used to accelerate your application, please refer to the Generic Work Queue Engine (GenWQE) Application Programming Guide published on IBM developerWorks (<http://www.ibm.com/developerworks/>).

PCIe2 LP 2-port 10 GbE BaseT RJ45 Adapter (FC EL3Z; CCIN 2CC4)

Learn about the specifications and operating system requirements for the feature code (FC) EL3Z adapter.

Overview

The PCIe2 LP 2-port 10 GbE BaseT RJ45 Adapter is a PCI Express (PCIe) generation 2, x8, short form-factor, low-profile adapter. The adapter provides two 10 Gb RJ45 ports. This adapter provides a PCIe 2.0 host bus interface. The adapter supports the Ethernet network interface controller (NIC) function. The adapter is a high-performance adapter that consolidates traffic for networking. The link aggregation and failover features of the adapter make it suitable for critical network applications that require redundancy and high availability. Figure 55 on page 63 shows the FC EL3Z adapter.

The ports default to auto negotiate the highest speed either at 10 Gb (10G BaseT), 1Gb (1000 BaseT), or 100 Mb (100 BaseT) full duplex. Each RJ45 port can be configured independent of the other port. Each RJ45 port is connected with a 4-pair, CAT-6A cable, and is supported for distances of up to 100 meters.

The adapter provides the following features:

- The adapter is a PCIe2 NIC network convergence adapter.
- The 10 Gb RJ45 ports can function in the NIC mode.
- The adapter can be used as the host local area network (LAN) adapter.
- The adapter supports interrupt moderation to deliver increased performance while significantly reducing processor utilization
- The adapter supports dual port operation in any PCIe3 or PCIe2 slot.

- The adapter supports auto-negotiation, full-duplex only.
- The adapter supports multiple media-access control (MAC) per interface.
- The adapter supports integrated media-access control (MAC) and physical layer (PHY).
- The adapter supports the following standards for the different ports and functions:
 - IEEE 802.3ae in the 10 GbE ports
 - 802.3ab in the 1 GbE ports
 - Ether II and IEEE 802.3 for encapsulated frames
 - 802.1p for setting up priority levels in tagged VLAN frames
 - 802.1Q for VLAN tagging
 - 802.3x for flow control
 - 802.3ad for load-balancing and failover
 - IEEE 802.3ad and 802.3 for link aggregation
- The adapter provides message signal interrupts (MSI), MSI-X, and support of legacy pin interrupts.
- The adapter supports jumbo frames up to 9.6 KB.
- The adapter supports gigabit EtherChannel (GEC) with the existing software.
- The adapter supports TCP checksum offload transmission control protocol (TCP), user datagram protocol (UDP), TCP segmentation Offload (TSO) for IPv4 and IPv6.
- Supports TCP segmentation or large send offload
- Supports EEPROM-SPI and single EEPROM
- Compliant with European Union Directive 2002/95/EC on the Restriction of the Use of Certain Hazardous Substances in Electrical and Electronic Equipment

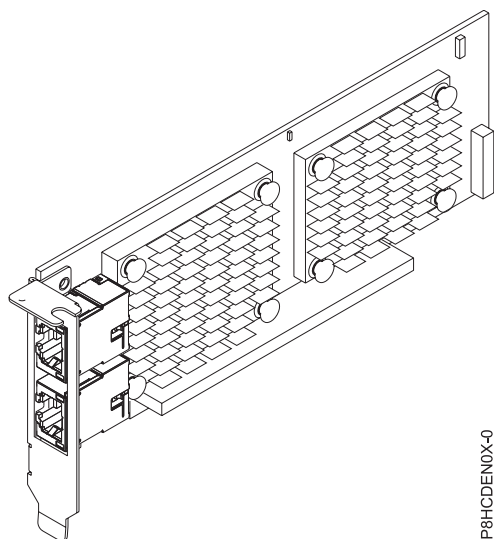

Figure 55. FC EL3Z adapter

Specifications

Item	Description
Adapter FRU number	00E2714 (Designed to comply with RoHS requirement)
	Regular-height tailstock part number: 00E2862
	Low-profile tailstock part number: 00E2721

Wrap plug FRU number

10N7405 (RJ45 wrap plug)

Note: Wrap plugs are not included with the card and cannot be purchased from IBM.

I/O bus architecture

PCIe2 x8

Slot requirement

For details about slot priorities and placement rules, see PCIe adapter placement rules and slot priorities (http://www.ibm.com/support/knowledgecenter/POWER8/p8eab/p8eab_mtm_pciplacement.htm) and select the system you are working on.

Cables

CAT-6A cable

Voltage

3.3 V

Form factor

Short, low-profile

Maximum number

For details about the maximum number of adapters that are supported, see PCIe adapter placement rules and slot priorities (http://www.ibm.com/support/knowledgecenter/POWER8/p8eab/p8eab_mtm_pciplacement.htm) and select the system you are working on.

Operating system or partition requirements

If you are installing a new feature, ensure that you have the software that is required to support the new feature and that you determine whether any prerequisites must be met for this feature and attaching devices. To check for the prerequisites, see IBM Prerequisite website (www-912.ibm.com/e_dir/eServerPrereq.nsf).

The adapter is supported on the following versions of the operating systems, depending on the system you are using:

- Linux
 - Red Hat Enterprise Linux Version 7, or later, with current maintenance updates available from Red Hat.
 - Red Hat Enterprise Linux Version 6.5, or later, with current maintenance updates available from Red Hat.
 - SUSE Linux Enterprise Server 11, Service Pack 3, or later, with current maintenance updates available from SUSE.
 - For support details, see the Linux Alert website (www14.software.ibm.com/webapp/set2/sas/f/lopdiags/info/LinuxAlerts.html).
- PowerKVM
 - IBM PowerKVM 2.1.1, or later

This adapter requires the following driver in the Linux operating system:

- bnx2x driver
- The latest version of the device driver or iprutils can be downloaded from the IBM Service and Productivity Tools website (<http://www14.software.ibm.com/webapp/set2/sas/f/lopdiags/home.html>).

PCIe3 LP 16 Gb 2-port Fibre Channel Adapter (FC EL43; CCIN 577F)

Learn about the specifications and operating system requirements for the feature code (FC) EL43 adapter.

Overview

The PCIe3 LP 16 Gb 2-port Fibre Channel Adapter is a low-profile, x8, generation 3, PCIe adapter. This adapter has a little connector-type (LC) external fiber connector that provides single initiator capability over an optical fiber link. The adapter automatically negotiates the highest data rate between the adapter and an attaching device at a link speed of 16 Gbps, 8 Gbps, or 4 Gbps. The adapter supports a maximum link speed of 16 Gbps at both ports. Distances between the adapter and an attaching device or switch can reach up to 380 m running at a 4 Gbps data rate, up to 150 m running at an 8 Gbps data rate, and up to 100 m running at a 16 Gbps data rate.

The adapter has the following features:

- This adapter has parts and construction compliant with the European Union Directive of Restriction of Hazardous Substances (RoHS)
- The adapter is compliant with the PCIe base and Card Electromechanical (CEM) 2.0 specifications with the following characteristics:
 - Provides an x8 lane link interface at 14.025 Gbps, 8.5 Gbps, or 4.25 Gbps (automatic negotiation with system)
 - Provides support for one Virtual Channel (VC0) and one Traffic Class (TC0)
 - Provides configuration and I/O memory read and write, completion, and messaging capabilities
 - Provides support for 64-bit addressing
 - Provides error correction code (ECC) and error protection functions
 - Provides link cyclic redundancy check (CRC) on all PCIe packets and message information
 - Provides a large payload size of 2048 bytes for read and write functions
 - Provides a large read request size of 4096 bytes
- The adapter is compatible with 4, 8, and 16 Gb Fibre Channel interface with the following characteristics:
 - Provides for automatic negotiation between 4 Gb, 8 Gb, or 16 Gb link attachments
 - Provides support for the following Fibre Channel topologies: point-to-point (16Gb only) and fabric
 - Provides support for Fibre Channel class 3
 - Provides a maximum Fibre Channel throughput that is achieved by using full duplex hardware support
- The adapter provides an end-to-end data path parity and CRC protection, including internal data path random-access memory (RAM)
- Provides architectural support for multiple upper layer protocols
- Provides comprehensive virtualization capabilities with support for N_Port ID Virtualization (NPIV) and virtual fabric (VF)
- Provides support for message signaled interrupts extended (MSI-X)
- Provides support for 255 VFs and 1024 MSi-X
- Provides an internal, high-speed static random-access memory (SRAM) memory
- Provides ECC protection of local memory that includes single-bit correction and double-bit protection
- Provides an embedded shortwave optical connection with diagnostics capability
- Provides support for an on-board context management by firmware:
 - Up to 8192 FC port logins
 - I/O multiplexing down to the Fibre Channel frame level
- Provides data buffers capable of supporting 64+ buffer-to-buffer (BB) credits per port for shortwave applications
- Provides link management and recovery that is handled by firmware
- Provides on-board diagnostic capability accessible by an optional connection

- Provides a performance up to 16 Gbps full duplex

The following figure shows the adapter.

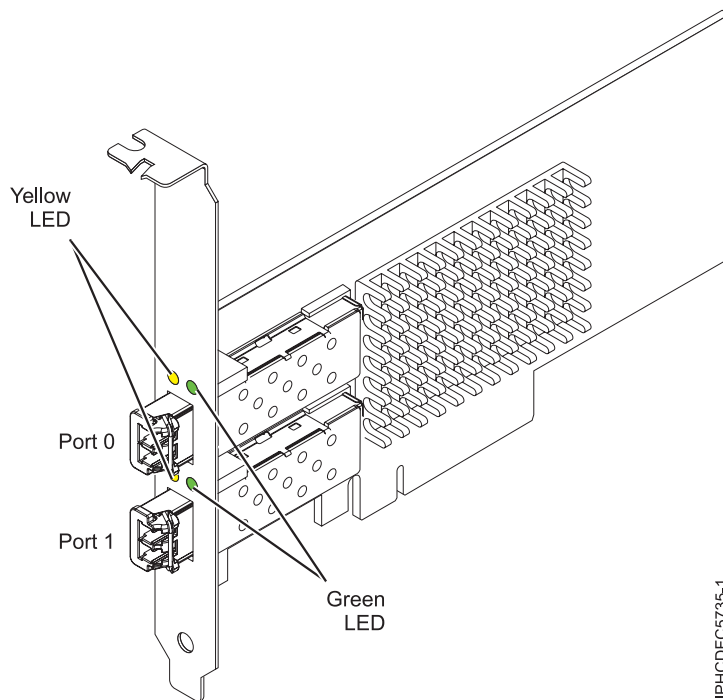

Figure 56. EL43 adapter

Specifications

Item	Description
Adapter FRU number	00E3496 (Designed to comply with RoHS requirement)
Wrap plug FRU number	12R9314
I/O bus architecture	PCIe3 x8
Slot requirement	One available PCIe x8 or x16 slot
Voltage	3.3 V, 12 V
Form factor	Short, low-profile
FC compatibility	4, 8, 16 Gb
Cables	

Cables are the responsibility of the customer. Use multimode fiber optic cables with shortwave lasers that adhere to the following specifications:

- OM4: Multimode 50/125 micron fiber, 4700 MHz x km bandwidth
- OM3: Multimode 50/125 micron fiber, 2000 MHz x km bandwidth
- OM2: Multimode 50/125 micron fiber, 500 MHz x km bandwidth
- OM1: Multimode 62.5/125 micron fiber, 200 MHz x km bandwidth

Because core sizes are different, OM1 cables can only be connected to other OM1 cables. For best results, OM2 cables must not be connected to OM3 cables. However, if an OM2 cable is connected to an OM3 cable, the characteristics of the OM2 cable apply to the entire length of the cables.

The following table shows the supported distances for the different cable types at the different link speeds.

Table 12. Supported distances for cables

Header	Cable type and distance			
	OM1	OM2	OM3	OM4
4.25 Gbps	0.5 - 70 m (1.64 - 229.65 ft)	0.5 - 150 m (1.64 - 492.12 ft)	0.5 - 380 m (1.64 - 1246.71 ft)	0.5 - 400 m (1.64 - 1312.34 ft)
8.5 Gbps	0.5 - 21 m (1.64 - 68.89 ft)	0.5 - 50 m (1.64 - 164.04 ft)	0.5 - 150 m (1.64 - 492.12 ft)	0.5 - 190 m (1.64 - 623.36 ft)
14.025 Gbps	0.5 - 15 m (1.64 - 49.21 ft)	0.5 - 35 m (1.64 - 114.82 ft)	0.5 - 100 m (1.64 - 328.08 ft)	0.5 - 125 m (1.64 - 410.10 ft)

Maximum number

For the maximum adapters supported, see the PCI adapter placement topic collection for your system.

Operating system or partition requirements

If you are installing a new feature, ensure that you have the software that is required to support the new feature and that you determine whether any prerequisites must be met for this feature and attaching devices. To check for the prerequisites, see IBM Prerequisite website (www-912.ibm.com/e_dir/eServerPrereq.nsf).

The adapter is supported on the following versions of the operating systems, depending on the system you are using:

- Linux
 - Red Hat Enterprise Linux Version 7, or later, with current maintenance updates available from Red Hat.
 - Red Hat Enterprise Linux Version 6.5, or later, with current maintenance updates available from Red Hat.
 - SUSE Linux Enterprise Server 11, Service Pack 3, or later, with current maintenance updates available from SUSE.
 - SUSE Linux Enterprise Server Version 12, or later
 - Linux Ubuntu 15.04, or later
 - The latest version of the device driver or iprutils can be downloaded from the IBM Service and Productivity Tools website(<http://www14.software.ibm.com/webapp/set2/sas/f/lopdiags/home.html>).
- PowerKVM
 - IBM PowerKVM 2.1.1, or later

Adapter LED states

Green and yellow LEDs can be seen through openings in the mounting bracket of the adapter. Green indicates firmware operation, and yellow signifies port activity. Table 13 summarizes normal LED states. A 1 Hz pause occurs when the LED is off between each group of fast flashes (2, 3 or 4). Observe the LED sequence for several seconds to ensure that you correctly identify the state.

Table 13. Normal LED states

Green LED	Yellow LED	State
On	2 fast flashes	4 Gbps link rate: normal, link active
On	3 fast flashes	8 Gbps link rate: normal, link active

Table 13. Normal LED states (continued)

Green LED	Yellow LED	State
On	4 fast flashes	16 Gbps link rate: normal, link active

Power-on-self-test (POST) conditions and results are summarized in Table 14. These states can be used to identify abnormal states or problems.

Table 14. POST conditions and results

Green LED	Yellow LED	State
Off	Off	Wake-up failure of the adapter board
Off	On	POST failure of the adapter board
Off	Slow flash	Wake-up failure monitor
Off	Fast flash	Failure in post
Off	Flashing	Postprocessing in progress
On	Off	Failure while functioning
On	On	Failure while functioning
Slow flash	Off	Normal, link down
Slow flash	On	Not defined
Slow flash	Slow flash	Offline for download
Slow flash	Fast flash	Restricted offline mode, waiting for restart
Slow flash	Flashing	Restricted offline mode, test active
Fast flash	Off	Debug monitor in restricted mode
Fast flash	On	Not defined
Fast flash	Slow flash	Debug monitor in test fixture mode
Fast flash	Fast flash	Debug monitor in remote debug mode
Fast flash	Flashing	Not defined

PCIe2 4-port 1 GbE Adapter (FC EL4L and EL4M; CCIN 576F)

Learn about the specifications and operating system requirements for the feature code (FC) EL4L and EL4M adapters.

Overview

FC EL4L and EL4M are both the same adapter with different feature codes. FC EL4L is a low-profile adapter and FC EL4M is a full-height adapter.

The PCIe2 LP 4-port 1 GbE Adapter is a full-height, generation 2 (Gen2) PCIe adapter. This adapter provides four 1-Gb Ethernet ports that can be configured to run at 1000 megabits per second (Mbps) or 1 gigabit per second (Gbps), 100 Mbps, or 10 Mbps. The adapter connects to a network that uses unshielded twisted pair (UTP) cable for distances of up to 100 meters (328.08 feet). The adapter supports AIX Network Installation Management (NIM) boot capability and conforms to the IEEE 802.3ab 1000Base-T standard. The adapter also supports jumbo frames when running at the 1000 Mbps speed.

Each of the Ethernet ports can be connected by using:

- CAT5e (or later) UTP cables for 1000 Mbps network attachment
- CAT5 or CAT3 UTP cables for 100 Mbps or 10 Mbps network attachment

The cables are attached to the copper RJ45 connectors. Each port is independent of one another and supports full-duplex or half-duplex. The half-duplex mode does not support a speed of 1000 Mbps.

The adapter provides the following features:

- Supports interrupt moderation to deliver increased performance while significantly reducing processor utilization
- Supports dual port operation in almost any PCIe slot, except x1
- Supports auto-negotiation, full-duplex only
- Supports integrated media-access control (MAC) and physical layer (PHY)
- Supports Fast EtherChannel (FEC) with the existing software
- Supports gigabit EtherChannel (GEC) with the existing software
- Supports IEEE 802.3ad (Link Aggregation control protocol)
- Supports IEEE 802.1Q VLANs
- Supports IEEE 802.3 z, ab, u, x flow control support
- Supports IEEE 802.1p
- Supports IEEE 802.3ab for TX
- Supports TCP checksum offload transmission control protocol (TCP), user datagram protocol (UDP), Internet Protocol (IP) for IPv4 and IPv6
- Supports TCP segmentation or large send offload
- Supports EEPROM-SPI and single EEPROM
- Supports interrupt levels INTA and MSI
- Hardware certifications FCC B, UL, CE, VCCI, BSMI, CTICK, MIC
- Network Controller (MAC) Intel 82571EB
- Compliant with European Union Directive 2002/95/EC on the Restriction of the Use of Certain Hazardous Substances in Electrical and Electronic Equipment

Specifications

Item Description

Adapter FRU number

74Y4064 (Designed to comply with RoHS requirement)

Wrap plug

10N7405

I/O bus architecture

PCIe2.0, x4

Slot requirement

One PCIe x4 slot.

Cables

4-pair, CAT5e, UTP cables are connected to copper RJ45 connectors.

Voltage

3.3 V

Form factor

Short, full-height

Maximum number

For details about the maximum number of adapters that are supported, see PCIe adapter placement rules and slot priorities (http://www.ibm.com/support/knowledgecenter/POWER8/p8eab/p8eab_mtm_pciplacement.htm) and select the system you are working on.

Connector information

- Two RJ-45 ports
- Two LED adapter status indicators per port, for link activity and speed

Attributes provided

- PCIe x4, generation 1 or generation 2

- 4-Port machine access code (MAC)
- High performance IPV4/IPV6 checksum offload
- Large Send and Large Receive Support
- Multiple Queues
- VIOS

The following figure shows the adapter.

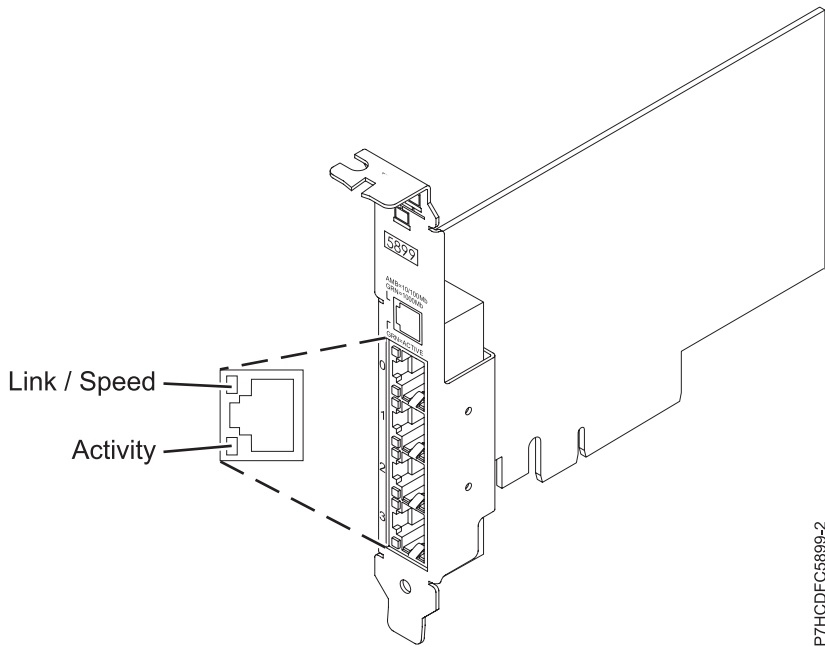

Figure 57. Adapter

Adapter LED states

The LEDs on the adapter provide information about the operation status of the adapter. The LEDs are visible through the mounting bracket. Figure 57 shows the location of the LEDs. Table 15 describes the different LED states and what those states indicate.

Table 15. Adapter LEDs and descriptions

LED	Light	Description
Link/Speed	Yellow	10 Mbps or 100 Mbps
	Green	1000 Mbps or 1 Gbps
Activity	Green flashing	Active link or data activity
	Off	No link The absence of a link can indicate a defective cable, defective connector, or a configuration mismatch.

Operating system or partition requirements

This adapter is supported for the following versions of operating systems:

- Linux
 - Bare Metal Systems (Not supported)
 - PowerKVM 3.1 Systems or PowerKVM 2.1 (Not Supported)

- Other environments
 - Red Hat Enterprise Linux 7 big-endian, or later
 - Red Hat Enterprise Linux 7.1, little-endian, or later
 - Red Hat Enterprise Linux 6.5 or later
 - SUSE Linux Enterprise Server 12, or later
 - SUSE Linux Enterprise Server 11, Service Pack 3, or later
 - Ubuntu 14.04.03, or later
 - For support details, see the Linux Alert website (www14.software.ibm.com/webapp/set2/sas/f/lopdiags/info/LinuxAlerts.html).
 - The latest version of the device driver or iprutils can be downloaded from the IBM Service and Productivity Tools website(<http://www14.software.ibm.com/webapp/set2/sas/f/lopdiags/home.html>).

PCIe2 4-port 1 GbE Adapter (FC EL4L and EL4M; CCIN 576F)

Learn about the specifications and operating system requirements for the feature code (FC) EL4L and EL4M adapters.

Overview

FC EL4L and EL4M are both the same adapter with different feature codes. FC EL4L is a low-profile adapter and FC EL4M is a full-height adapter.

The PCIe2 LP 4-port 1 GbE Adapter is a full-height, generation 2 (Gen2) PCIe adapter. This adapter provides four 1-Gb Ethernet ports that can be configured to run at 1000 megabits per second (Mbps) or 1 gigabit per second (Gbps), 100 Mbps, or 10 Mbps. The adapter connects to a network that uses unshielded twisted pair (UTP) cable for distances of up to 100 meters (328.08 feet). The adapter supports AIX Network Installation Management (NIM) boot capability and conforms to the IEEE 802.3ab 1000Base-T standard. The adapter also supports jumbo frames when running at the 1000 Mbps speed.

Each of the Ethernet ports can be connected by using:

- CAT5e (or later) UTP cables for 1000 Mbps network attachment
- CAT5 or CAT3 UTP cables for 100 Mbps or 10 Mbps network attachment

The cables are attached to the copper RJ45 connectors. Each port is independent of one another and supports full-duplex or half-duplex. The half-duplex mode does not support a speed of 1000 Mbps.

The adapter provides the following features:

- Supports interrupt moderation to deliver increased performance while significantly reducing processor utilization
- Supports dual port operation in almost any PCIe slot, except x1
- Supports auto-negotiation, full-duplex only
- Supports integrated media-access control (MAC) and physical layer (PHY)
- Supports Fast EtherChannel (FEC) with the existing software
- Supports gigabit EtherChannel (GEC) with the existing software
- Supports IEEE 802.3ad (Link Aggregation control protocol)
- Supports IEEE 802.1Q VLANs
- Supports IEEE 802.3 z, ab, u, x flow control support
- Supports IEEE 802.1p
- Supports IEEE 802.3ab for TX
- Supports TCP checksum offload transmission control protocol (TCP), user datagram protocol (UDP), Internet Protocol (IP) for IPv4 and IPv6

- Supports TCP segmentation or large send offload
- Supports EEPROM-SPI and single EEPROM
- Supports interrupt levels INTA and MSI
- Hardware certifications FCC B, UL, CE, VCCI, BSMI, CTICK, MIC
- Network Controller (MAC) Intel 82571EB
- Compliant with European Union Directive 2002/95/EC on the Restriction of the Use of Certain Hazardous Substances in Electrical and Electronic Equipment

Specifications

Item Description

Adapter FRU number

74Y4064 (Designed to comply with RoHS requirement)

Wrap plug

10N7405

I/O bus architecture

PCIe2.0, x4

Slot requirement

One PCIe x4 slot.

Cables

4-pair, CAT5e, UTP cables are connected to copper RJ45 connectors.

Voltage

3.3 V

Form factor

Short, full-height

Maximum number

For details about the maximum number of adapters that are supported, see PCIe adapter placement rules and slot priorities (http://www.ibm.com/support/knowledgecenter/POWER8/p8eab/p8eab_mtm_pciplacement.htm) and select the system you are working on.

Connector information

- Two RJ-45 ports
- Two LED adapter status indicators per port, for link activity and speed

Attributes provided

- PCIe x4, generation 1 or generation 2
- 4-Port machine access code (MAC)
- High performance IPV4/IPV6 checksum offload
- Large Send and Large Receive Support
- Multiple Queues
- VIOS

The following figure shows the adapter.

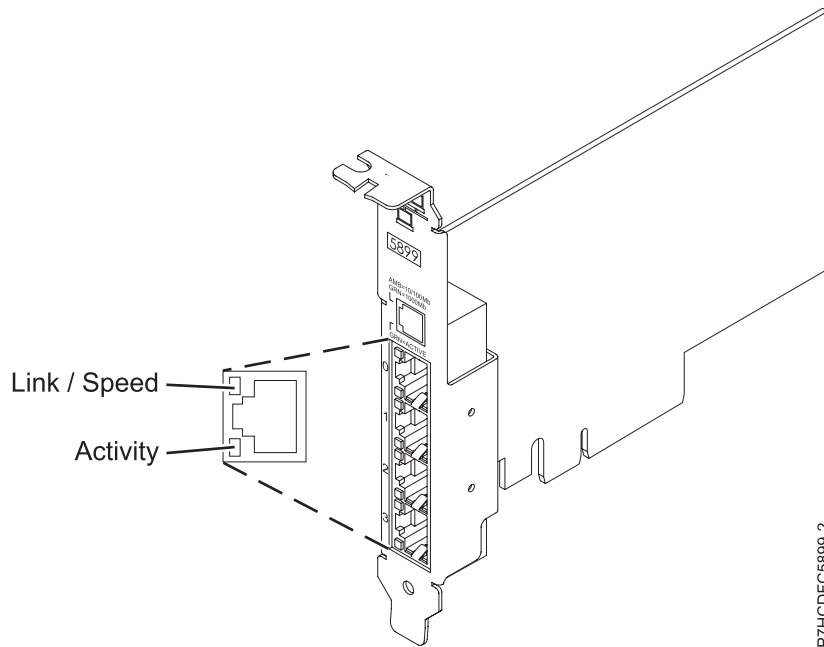

Figure 58. Adapter

Adapter LED states

The LEDs on the adapter provide information about the operation status of the adapter. The LEDs are visible through the mounting bracket. Figure 57 on page 70 shows the location of the LEDs. Table 15 on page 70 describes the different LED states and what those states indicate.

Table 16. Adapter LEDs and descriptions

LED	Light	Description
Link/Speed	Yellow	10 Mbps or 100 Mbps
	Green	1000 Mbps or 1 Gbps
Activity	Green flashing	Active link or data activity
	Off	No link The absence of a link can indicate a defective cable, defective connector, or a configuration mismatch.

Operating system or partition requirements

This adapter is supported for the following versions of operating systems:

- Linux
 - Bare Metal Systems (Not supported)
 - PowerKVM 3.1 Systems or PowerKVM 2.1 (Not Supported)
 - Other environments
 - Red Hat Enterprise Linux 7 big-endian, or later
 - Red Hat Enterprise Linux 7.1, little-endian, or later
 - Red Hat Enterprise Linux 6.5 or later
 - SUSE Linux Enterprise Server 12, or later
 - SUSE Linux Enterprise Server 11, Service Pack 3, or later

- Ubuntu 14.04.03, or later
- For support details, see the Linux Alert website (www14.software.ibm.com/webapp/set2/sas/f/lopdiags/info/LinuxAlerts.html).
- The latest version of the device driver or iprutils can be downloaded from the IBM Service and Productivity Tools website(<http://www14.software.ibm.com/webapp/set2/sas/f/lopdiags/home.html>).

PCIe2 2-port 10 GbE BaseT RJ45 Adapter (FC EL55; CCIN 2CC4)

Learn about the specifications and operating system requirements for the feature code (FC) EL55 adapter.

Overview

The PCIe2 2-port 10 GbE BaseT RJ45 Adapter is a PCI Express (PCIe) generation 2, x8, short form-factor, low-profile capable, regular-height adapter. The adapter provides two 10 Gb RJ45 ports. This adapter provides a PCIe 2.0 host bus interface. The adapter supports the Ethernet network interface controller (NIC) function. The adapter is a high-performance adapter that consolidates traffic for networking. The link aggregation and failover features of the adapter make it suitable for critical network applications that require redundancy and high availability. Figure 59 on page 75 shows the FC EL55 adapter.

The ports default to auto negotiate the highest speed either at 10 Gb (10G BaseT), 1Gb (1000 BaseT), or 100 Mb (100 BaseT) full duplex. Each RJ45 port can be configured independent of the other port. Each RJ45 port is connected with a 4-pair, CAT-6A cable, and is supported for distances of up to 100 meters.

The adapter provides the following features:

- The adapter is a PCIe2 NIC network convergence adapter.
- The 10 Gb RJ45 ports can function in the NIC mode.
- The adapter can be used as the host local area network (LAN) adapter.
- The adapter supports interrupt moderation to deliver increased performance while significantly reducing processor utilization
- The adapter supports dual port operation in any PCIe3 or PCIe2 slot.
- The adapter supports auto-negotiation, full-duplex only.
- The adapter supports multiple media-access control (MAC) per interface.
- The adapter supports integrated media-access control (MAC) and physical layer (PHY).
- The adapter supports the following standards for the different ports and functions:
 - IEEE 802.3ae in the 10 GbE ports
 - 802.3ab in the 1 GbE ports
 - Ether II and IEEE 802.3 for encapsulated frames
 - 802.1p for setting up priority levels in tagged VLAN frames
 - 802.1Q for VLAN tagging
 - 802.3x for flow control
 - 802.3ad for load-balancing and failover
 - IEEE 802.3ad and 802.3 for link aggregation
- The adapter provides message signal interrupts (MSI), MSI-X, and support of legacy pin interrupts.
- The adapter supports jumbo frames up to 9.6 KB.
- The adapter supports gigabit EtherChannel (GEC) with the existing software.
- The adapter supports TCP checksum offload transmission control protocol (TCP), user datagram protocol (UDP), TCP segmentation Offload (TSO) for IPv4 and IPv6.
- Supports TCP segmentation or large send offload
- Supports EEPROM-SPI and single EEPROM

- Compliant with European Union Directive 2002/95/EC on the Restriction of the Use of Certain Hazardous Substances in Electrical and Electronic Equipment

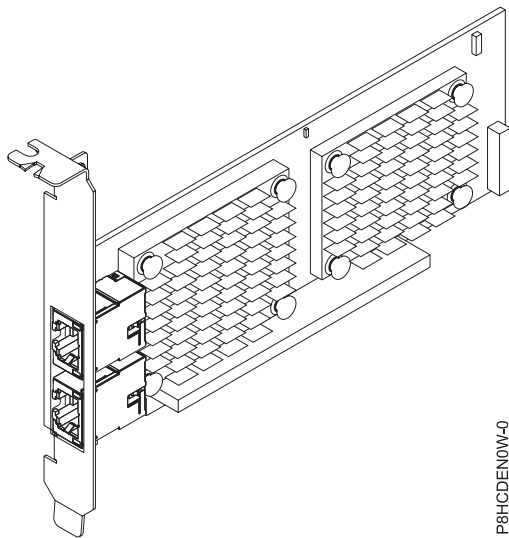

Figure 59. FC EL55 adapter

Specifications

Item Description

Adapter FRU number

00E2714 (Designed to comply with RoHS requirement)

Regular-height tailstock part number: 00E2862

Low-profile tailstock part number: 00E2721

Wrap plug FRU number

10N7405 (RJ45 wrap plug)

I/O bus architecture

PCIe2 x8

Slot requirement

For details about slot priorities and placement rules, see PCIe adapter placement rules and slot priorities (http://www.ibm.com/support/knowledgecenter/POWER8/p8eab/p8eab_mtm_pciplacement.htm) and select the system you are working on.

Cables

CAT-6A cable

Voltage

3.3 V

Form factor

Short, regular-height tailstock, low-profile capable

Maximum number

For details about the maximum number of adapters that are supported, see PCIe adapter placement rules and slot priorities (http://www.ibm.com/support/knowledgecenter/POWER8/p8eab/p8eab_mtm_pciplacement.htm) and select the system you are working on.

Operating system or partition requirements

If you are installing a new feature, ensure that you have the software that is required to support the new feature and that you determine whether any prerequisites must be met for this feature and attaching devices. To check for the prerequisites, see IBM Prerequisite website (www-912.ibm.com/e_dir/eServerPrereq.nsf).

The adapter is supported on the following versions of the operating systems, depending on the system you are using:

- AIX
 - AIX 7.1, Technology Level 3, Service Pack 2, or later
 - AIX 7.1, Technology Level 2, Service Pack 2, or later
 - AIX 7.1, Technology Level 1, Service Pack 3, or later
 - AIX 6.1, Technology Level 9, Service Pack 2, or later
 - AIX 6.1, Technology Level 8, Service Pack 3, or later
 - AIX 6.1, Technology Level 7, Service Pack 2, or later
- Linux
 - Red Hat Enterprise Linux Version 6.5, or later, with current maintenance updates available from Red Hat.
 - SUSE Linux Enterprise Server 11, Service Pack 3, or later, with current maintenance updates available from SUSE.
 - For support details, see the Linux Alert website (www14.software.ibm.com/webapp/set2/sas/f/lopdiags/info/LinuxAlerts.html).
- IBM i
 - IBM i is supported only with VIOS

This adapter requires the following drivers:

- AIX: `devices.pciex.e4148e1614109204`
- Linux: `bnx2x` driver
- The latest version of the device driver or `iprutils` can be downloaded from the IBM Service and Productivity Tools website (<http://www14.software.ibm.com/webapp/set2/sas/f/lopdiags/home.html>).

PCIe2 16 Gb 2-port Fibre Channel Adapter (FC EL5B; CCIN 577F)

Learn about the specifications and operating system requirements for the feature code (FC) EL5B adapter.

Overview

The PCIe2 16 Gb 2-port Fibre Channel Adapter is an x8, generation 2, PCIe adapter. This adapter is a high-performance 8x short form adapter also referred to as a PCIe Host Bus Adapter (HBA). The adapter provides two ports of 16 Gb Fibre Channel capability using SR optics. Each port can provide up to 16 Gb Fibre Channel functions simultaneously.

Each port provides single initiator capability over a fibre link or with NPIV, multiple initiator capability is provided. The ports are SFP+ and include an optical SR transceiver. The ports have little connector-type (LC) and utilize shortwave laser optics. The adapter operates at link speeds of 4, 8 and 16 Gbps and will automatically negotiate to the highest speed possible. LEDs on each port provide information on the status and link speed of the port.

N_Port ID Virtualization (NPIV) capability is supported through VIOS.

The adapter has the following features:

- This adapter has parts and construction compliant with the European Union Directive of Restriction of Hazardous Substances (RoHS)
- The adapter is compliant with the PCIe base and Card Electromechanical (CEM) 2.0 specifications with the following characteristics:
 - Provides an x8 lane link interface at 14.025 Gbps, 8.5 Gbps, or 4.25 Gbps (automatic negotiation with system)

- Provides support for one Virtual Channel (VC0) and one Traffic Class (TC0)
- Provides configuration and I/O memory read and write, completion, and messaging capabilities
- Provides support for 64-bit addressing
- Provides error correction code (ECC) and error protection functions
- Provides link cyclic redundancy check (CRC) on all PCIe packets and message information
- Provides a large payload size of 2048 bytes for read and write functions
- Provides a large read request size of 4096 bytes
- The adapter is compatible with 4, 8, and 16 Gb Fibre Channel interface with the following characteristics:
 - Provides for automatic negotiation between 4 Gb, 8 Gb, or 16 Gb link attachments
 - Provides support for the following Fibre Channel topologies: point-to-point (16Gb only) and fabric
 - Provides support for Fibre Channel class 3
 - Provides a maximum Fibre Channel throughput that is achieved by using full duplex hardware support
- The adapter provides an end-to-end data path parity and CRC protection, including internal data path random-access memory (RAM)
- Provides architectural support for multiple upper layer protocols
- Provides comprehensive virtualization capabilities with support for N_Port ID Virtualization (NPIV) and virtual fabric (VF)
- Provides support for message signaled interrupts extended (MSI-X)
- Provides support for 255 VFs and 1024 MSi-X
- Provides an internal, high-speed static random-access memory (SRAM) memory
- Provides ECC protection of local memory that includes single-bit correction and double-bit protection
- Provides an embedded shortwave optical connection with diagnostics capability
- Provides support for an on-board context management by firmware:
 - Up to 8192 FC port logins
 - I/O multiplexing down to the Fibre Channel frame level
- Provides data buffers capable of supporting 64+ buffer-to-buffer (BB) credits per port for shortwave applications
- Provides link management and recovery that is handled by firmware
- Provides on-board diagnostic capability accessible by an optional connection
- Provides a performance up to 16 Gbps full duplex

The following figure shows the adapter.

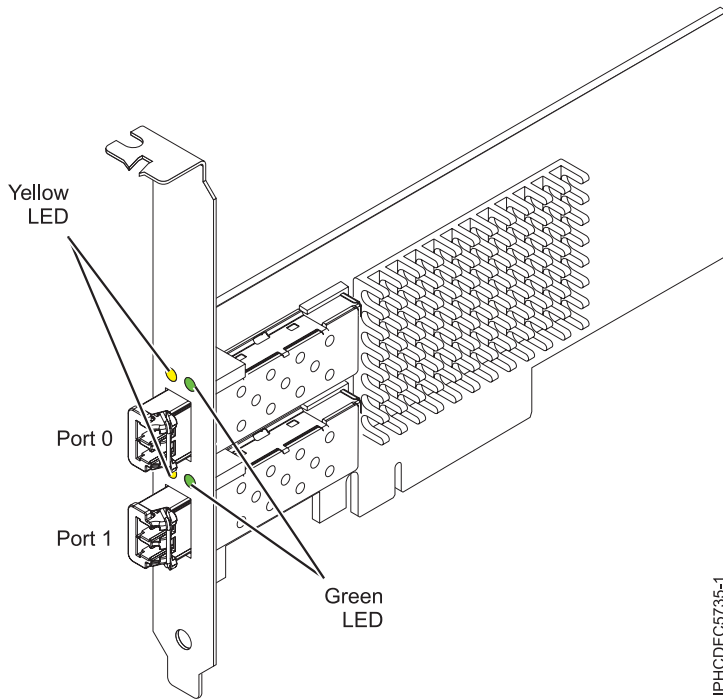

Figure 60. EL5B adapter

Specifications

Item	Description
Adapter FRU number	00E3496 (Designed to comply with RoHS requirement)
Wrap plug FRU number	12R9314
I/O bus architecture	PCIe2 x8
Slot requirement	One available PCIe x8 or x16 slot
Voltage	3.3 V, 12 V
Form factor	Short, MD2
FC compatibility	4, 8, 16 Gb

Cables

Cables are the responsibility of the customer. Use multimode fiber optic cables with shortwave lasers that adhere to the following specifications:

- OM4: Multimode 50/125 micron fiber, 4700 MHz x km bandwidth
- OM3: Multimode 50/125 micron fiber, 2000 MHz x km bandwidth
- OM2: Multimode 50/125 micron fiber, 500 MHz x km bandwidth
- OM1: Multimode 62.5/125 micron fiber, 200 MHz x km bandwidth

Because core sizes are different, OM1 cables can only be connected to other OM1 cables. For best results, OM2 cables must not be connected to OM3 cables. However, if an OM2 cable is connected to an OM3 cable, the characteristics of the OM2 cable apply to the entire length of the cables.

The following table shows the supported distances for the different cable types at the different link speeds.

Table 17. Supported distances for cables

Header	Cable type and distance			
	OM1	OM2	OM3	OM4
4.25 Gbps	0.5 - 70 m (1.64 - 229.65 ft)	0.5 - 150 m (1.64 - 492.12 ft)	0.5 - 380 m (1.64 - 1246.71 ft)	0.5 - 400 m (1.64 - 1312.34 ft)
8.5 Gbps	0.5 - 21 m (1.64 - 68.89 ft)	0.5 - 50 m (1.64 - 164.04 ft)	0.5 - 150 m (1.64 - 492.12 ft)	0.5 - 190 m (1.64 - 623.36 ft)
14.025 Gbps	0.5 - 15 m (1.64 - 49.21 ft)	0.5 - 35 m (1.64 - 114.82 ft)	0.5 - 100 m (1.64 - 328.08 ft)	0.5 - 125 m (1.64 - 410.10 ft)

Maximum number

For the maximum adapters supported, see the PCI adapter placement topic collection for your system.

Operating system or partition requirements

If you are installing a new feature, ensure that you have the software that is required to support the new feature and that you determine whether any prerequisites must be met for this feature and attaching devices. To check for the prerequisites, see IBM Prerequisite website (www-912.ibm.com/e_dir/eServerPrereq.nsf).

The adapter is supported on the following versions of the operating systems, depending on the system you are using:

- Linux
 - Red Hat Enterprise Linux Version 7.1, or later
 - Red Hat Enterprise Linux Version 7.1, little endian, or later
 - Red Hat Enterprise Linux Version 6.5, or later
 - SUSE Linux Enterprise Server 11, Service Pack 3, or later
 - SUSE Linux Enterprise Server 12, or later
 - Ubuntu Server 14.04.3, or later
 - Ubuntu Server 16.04, or later
- Supports PowerKVM and VIOS.

Adapter LED states

Green and yellow LEDs can be seen through openings in the mounting bracket of the adapter. Green indicates firmware operation, and yellow signifies port activity. Table 18 summarizes normal LED states. A 1 Hz pause occurs when the LED is off between each group of fast flashes (2, 3 or 4). Observe the LED sequence for several seconds to ensure that you correctly identify the state.

Table 18. Normal LED states

Green LED	Yellow LED	State
On	2 fast flashes	4 Gbps link rate: normal, link active
On	3 fast flashes	8 Gbps link rate: normal, link active
On	4 fast flashes	16 Gbps link rate: normal, link active

Power-on-self-test (POST) conditions and results are summarized in Table 19 on page 80. These states can be used to identify abnormal states or problems.

Table 19. POST conditions and results

Green LED	Yellow LED	State
Off	Off	Wake-up failure of the adapter board
Off	On	POST failure of the adapter board
Off	Slow flash	Wake-up failure monitor
Off	Fast flash	Failure in post
Off	Flashing	Postprocessing in progress
On	Off	Failure while functioning
On	On	Failure while functioning
Slow flash	Off	Normal, link down
Slow flash	On	Not defined
Slow flash	Slow flash	Offline for download
Slow flash	Fast flash	Restricted offline mode, waiting for restart
Slow flash	Flashing	Restricted offline mode, test active
Fast flash	Off	Debug monitor in restricted mode
Fast flash	On	Not defined
Fast flash	Slow flash	Debug monitor in test fixture mode
Fast flash	Fast flash	Debug monitor in remote debug mode
Fast flash	Flashing	Not defined

PCIe3 4-Port (10 Gb + 1 GbE) SR+RJ45 Adapter (FC EN0S; CCIN 2CC3)

Learn about the specifications and operating system requirements for the feature code (FC) EN0S adapter.

Overview

The PCIe3 4-Port (10 Gb + 1 GbE) SR+RJ45 Adapter is a PCI Express (PCIe) generation 3 (Gen3) x8, short form-factor, low-profile capable, full-height adapter. The adapter provides two 10 Gb SR optical ports and two 1 Gb RJ45 ports. This adapter provides a PCIe 3.0 host bus interface. The adapter supports the Ethernet network interface controller (NIC) function. The adapter is a high-performance adapter that consolidates traffic for networking. The link aggregation and failover features of the adapter make it suitable for critical network applications that require redundancy and high availability.

The four-port adapter provides two 10 Gb small form-factor pluggable (SFP+) optical SR transceiver ports and two 1 Gb RJ45 Ethernet ports. The two 10 Gb SR ports have little connector (LC) duplex-type connectors. The optical transceiver uses shortwave laser optics and is attached with MMF-850nm fiber cabling with LC connectors. See “Cables” on page 83 for more information about the optical cables. Each 10 Gb port provides Ethernet connectivity with a nominal data rate of 10 Gbps (gigabits per second). Figure 61 on page 82 shows the FC EN0S adapter.

Each of the 1 Gb RJ45 port provides Ethernet connectivity at a data rate of 1 Gbps. Each of the 1 Gb ports is connected with a 4-pair, CAT-5 unshielded twisted pair (UTP) cable or with a cable of higher specification, and is supported for distances of up to 100 meters. In addition to 1 Gb (1000 Mb) networks, 100 Mb networks are also supported.

The adapter provides the following features:

- The adapter is a PCIe3 NIC network convergence adapter.
- The 10 Gb SR ports can function in the NIC mode.

- The adapter can be used as the host local area network (LAN) adapter.
- The adapter supports interrupt moderation to deliver increased performance while significantly reducing processor utilization
- The adapter supports dual port operation in any PCIe3 slot
- The adapter supports auto-negotiation, full-duplex only.
- The adapter supports multiple media-access control (MAC) per interface.
- The adapter supports integrated media-access control (MAC) and physical layer (PHY).
- The adapter supports the following standards for the different ports and functions:
 - IEEE 802.3ae in the 10 GbE ports
 - 802.3ab in the 1 GbE ports
 - Ether II and IEEE 802.3 for encapsulated frames
 - 802.1p for setting up priority levels in tagged VLAN frames
 - 802.1Q for VLAN tagging
 - 802.3x for flow control
 - 802.3ad for load-balancing and failover
 - IEEE 802.3ad and 802.3 for link aggregation
- The adapter provides message signal interrupts (MSI), MSI-X, and support of legacy pin interrupts.
- The adapter supports jumbo frames up to 9.6 KB.
- The adapter supports gigabit EtherChannel (GEC) with the existing software.
- The adapter supports TCP checksum offload transmission control protocol (TCP), user datagram protocol (UDP), TCP segmentation Offload (TSO) for IPv4 and IPv6.
- Supports TCP segmentation or large send offload
- Supports EEPROM-SPI and single EEPROM
- Compliant with European Union Directive 2002/95/EC on the Restriction of the Use of Certain Hazardous Substances in Electrical and Electronic Equipment

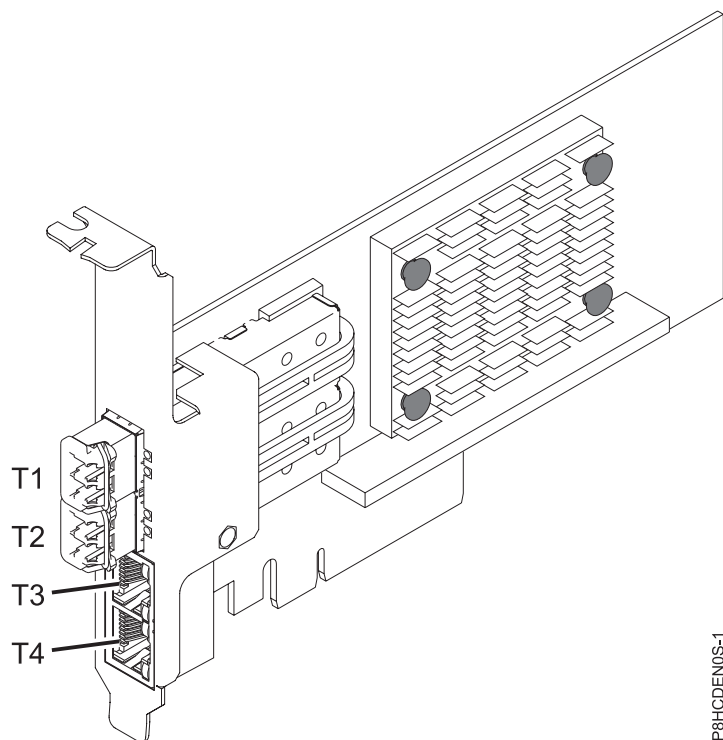

P8HCDE005-1

Figure 61. FC EN0S adapter

Note: The ports are numbered from top to bottom as T1, T2, and so on for the AIX and IBM i operating systems.

Specifications

Item Description

Adapter FRU number

00E2715 (Designed to comply with RoHS requirement)

Regular-height tailstock part number: 00E2863

Low-profile tailstock part number: 00E2720

Wrap plug FRU number

12R9314 (SFP+ SR wrap plug)

10N7405 (1 Gb UTP wrap plug)

Note: These wrap plugs are not included with the card. 12R9314 (FC ECW0) is the only wrap plug that can be purchased from IBM.

I/O bus architecture

PCIe3 x8

Slot requirement

For details about slot priorities and placement rules, see PCIe adapter placement rules and slot priorities (http://www.ibm.com/support/knowledgecenter/POWER8/p8eab/p8eab_mtm_pciplacement.htm) and select the system you are working on.

Cables

See “Cables” on page 83 for details.

Voltage

3.3 V

Form factor

Short, with full-height tailstock

Low-profile capable

Maximum number

For details about the maximum number of adapters that are supported, see PCIe adapter placement rules and slot priorities (http://www.ibm.com/support/knowledgecenter/POWER8/p8eab/p8eab_mtm_pciplacement.htm) and select the system you are working on.

Cables

Use multimode fiber optic cables with shortwave lasers that adhere to the following specifications:

- OM3 or OM4: Multimode 50/125 micron fiber, 2000 MHz x km bandwidth
- OM2: Multimode 50/125 micron fiber, 500 MHz x km bandwidth
- OM1: Multimode 62.5/125 micron fiber, 200 MHz x km bandwidth

Because core sizes are different, OM1 cables only can be connected to other OM1 cables. For best results, OM2 cables must not be connected to OM3 or OM4 cables. However, if an OM2 cable is connected to an OM3 or OM4 cable, the characteristics of the OM2 cable apply to the entire length of the cables. The following table shows the supported distances for the different fiber optic cable types at different link speeds.

Table 20. Supported distances for multimode fiber optic cables

Header	Cable Type and Distance		
	OM1	OM2	OM3
Rate			
10 Gbps	0.5 meters to 33 meters (1.64 feet to 108.26 feet)	0.5 meters to 82 meters (1.64 feet to 269.02 feet)	0.5 meters to 300 meters (1.64 feet to 984.25 feet)

Operating system or partition requirements

If you are installing a new feature, ensure that you have the software that is required to support the new feature and that you determine whether any prerequisites must be met for this feature and attaching devices. To check for the prerequisites, see IBM Prerequisite website (www-912.ibm.com/e_dir/eServerPrereq.nsf).

The adapter is supported on the following versions of the operating systems, depending on the system you are using:

- AIX
 - AIX 7.1 with the 7100-03 Technology Level and Service Pack 3, or later
 - AIX 6.1, Technology Level 9, Service Pack 2, or later
- Linux
 - Red Hat Enterprise Linux Version 7.1, or later
 - Red Hat Enterprise Linux Version 7.1, little endian, or later
 - Red Hat Enterprise Linux Version 6.6, or later
 - SUSE Linux Enterprise Server 11, Service Pack 4, or later
 - SUSE Linux Enterprise Server 12, or later
 - Ubuntu Server 16.04, or later
 - Ubuntu Server 14.04.3, or later
- IBM i
 - IBM i is supported only with VIOS

This adapter requires the following drivers:

- AIX: `devices.pciex.e4148a1614109304` for SFP+ optical ports and `devices.pciex.e4148a1614109404` for RJ45 ports

- Linux: bnx2x driver
- The latest version of the device driver or iprutils can be downloaded from the IBM Service and Productivity Tools website(<http://www14.software.ibm.com/webapp/set2/sas/f/lopdiags/home.html>).

PCIe3 LP 4-Port (10Gb+1GbE) SR+RJ45 Adapter (FC EN0T; CCIN 2CC3)

Learn about the specifications and operating system requirements for the feature code (FC) EN0T adapter.

Overview

The PCIe3 LP 4-Port (10Gb+1GbE) SR+RJ45 Adapter is a PCI Express (PCIe) generation 2 (Gen2) x8, short form-factor, low-profile adapter. The adapter provides two 10 Gb SR optical ports and two 1 Gb RJ45 ports. This adapter provides a PCIe 2.0 host bus interface. The adapter supports the Ethernet network interface controller (NIC) function. The adapter is a high-performance adapter that consolidates traffic for networking. The link aggregation and failover features of the adapter make it suitable for critical network applications that require redundancy and high availability.

The four-port adapter provides two 10 Gb small form-factor pluggable (SFP+) optical SR transceiver ports and two 1 Gb RJ45 Ethernet ports. The two 10 Gb SR ports have little connector (LC) duplex-type connectors. The optical transceiver uses shortwave laser optics and is attached with MMF-850nm fiber cabling with LC connectors. See “Cables” on page 86 for more information about the optical cables. Each 10 Gb port provides Ethernet connectivity with a nominal data rate of 10 Gbps (gigabits per second). Figure 62 on page 85 shows the FC EN0T adapter.

Each of the 1 Gb RJ45 port provides Ethernet connectivity at a data rate of 1 Gbps. Each of the 1 Gb ports is connected with a 4-pair, CAT-5 unshielded twisted pair (UTP) cable or with a cable of higher specification, and is supported for distances of up to 100 meters. In addition to 1 Gb (1000 Mb) networks, 100 Mb networks are also supported.

The adapter provides the following features:

- The adapter is a PCIe3 NIC network convergence adapter.
- The 10 Gb SR ports can function in the NIC mode.
- The adapter can be used as the host local area network (LAN) adapter.
- The adapter supports interrupt moderation to deliver increased performance while significantly reducing processor utilization
- The adapter supports dual port operation in any PCIe3 or PCIe2 slot.
- The adapter supports auto-negotiation, full-duplex only.
- The adapter supports multiple media-access control (MAC) per interface.
- The adapter supports integrated media-access control (MAC) and physical layer (PHY).
- The adapter supports the following standards for the different ports and functions:
 - IEEE 802.3ae in the 10 GbE ports
 - 802.3ab in the 1 GbE ports
 - Ether II and IEEE 802.3 for encapsulated frames
 - 802.1p for setting up priority levels in tagged VLAN frames
 - 802.1Q for VLAN tagging
 - 802.3x for flow control
 - 802.3ad for load-balancing and failover
 - IEEE 802.3ad and 802.3 for link aggregation
- The adapter provides message signal interrupts (MSI), MSI-X, and support of legacy pin interrupts.
- The adapter supports jumbo frames up to 9.6 KB.
- The adapter supports gigabit EtherChannel (GEC) with the existing software.

- The adapter supports TCP checksum offload transmission control protocol (TCP), user datagram protocol (UDP), TCP segmentation Offload (TSO) for IPv4 and IPv6.
- Supports TCP segmentation or large send offload
- Supports EEPROM-SPI and single EEPROM
- Compliant with European Union Directive 2002/95/EC on the Restriction of the Use of Certain Hazardous Substances in Electrical and Electronic Equipment

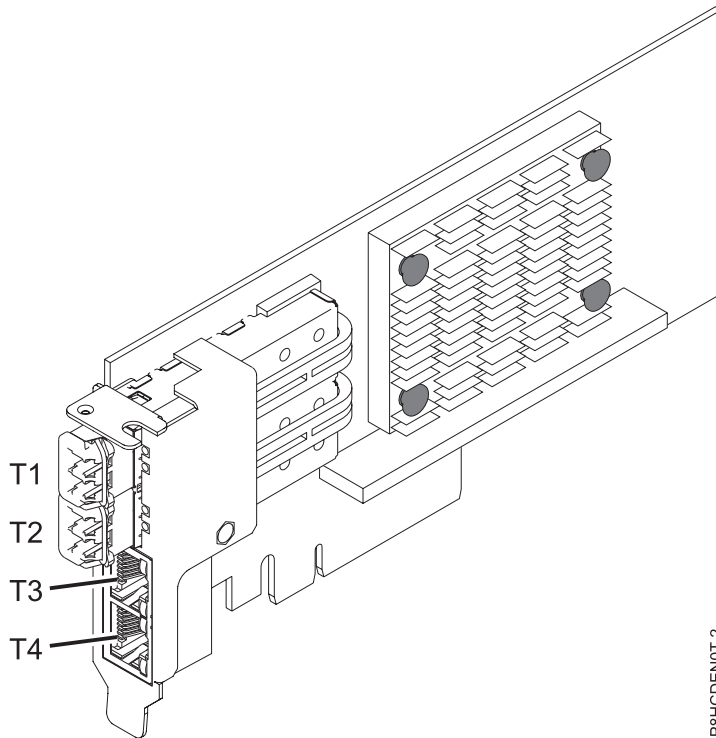

Figure 62. FC EN0T adapter

Note: The ports are numbered from top to bottom of the adapter as T1, T2, and so on for the AIX® and IBM® i operating systems.

Specifications

Item Description
Adapter FRU number
 00E2715 (Designed to comply with RoHS requirement)

Low-profile tailstock part number: 00E2720

Wrap plug FRU number
 12R9314 (SFP+ SR wrap plug)
 10N7405 (1 Gb UTP wrap plug)

Note: These wrap plugs are not included with the card. 12R9314 (FC ECW0) is the only wrap plug that can be purchased from IBM.

I/O bus architecture
 PCIe3 x8

Slot requirement
 For details about slot priorities and placement rules, see PCIe adapter placement rules and slot

priorities (http://www.ibm.com/support/knowledgecenter/POWER8/p8eab/p8eab_mtm_pciplacement.htm) and select the system you are working on.

Voltage

3.3 V

Form factor

Short, low-profile

Maximum number

For details about the maximum number of adapters that are supported, see PCIe adapter placement rules and slot priorities (http://www.ibm.com/support/knowledgecenter/POWER8/p8eab/p8eab_mtm_pciplacement.htm) and select the system you are working on.

Cables

Use multimode fiber optic cables with shortwave lasers that adhere to the following specifications:

- OM3 or OM4: Multimode 50/125 micron fiber, 2000 MHz x km bandwidth
- OM2: Multimode 50/125 micron fiber, 500 MHz x km bandwidth
- OM1: Multimode 62.5/125 micron fiber, 200 MHz x km bandwidth

Because core sizes are different, OM1 cables only can be connected to other OM1 cables. For best results, OM2 cables must not be connected to OM3 or OM4 cables. However, if an OM2 cable is connected to an OM3 or OM4 cable, the characteristics of the OM2 cable apply to the entire length of the cables. The following table shows the supported distances for the different fiber optic cable types at different link speeds.

Table 21. Supported distances for multimode fiber optic cables

Header	Cable Type and Distance		
	OM1	OM2	OM3
Rate			
10 Gbps	0.5 meters to 33 meters (1.64 feet to 108.26 feet)	0.5 meters to 82 meters (1.64 feet to 269.02 feet)	0.5 meters to 300 meters (1.64 feet to 984.25 feet)

Operating system or partition requirements

If you are installing a new feature, ensure that you have the software that is required to support the new feature and that you determine whether any prerequisites must be met for this feature and attaching devices. To check for the prerequisites, see IBM Prerequisite website (www-912.ibm.com/e_dir/eServerPrereq.nsf).

The adapter is supported on the following versions of the operating systems, depending on the system you are using:

- AIX
 - AIX 7.1 with the 7100-03 Technology Level and Service Pack 3, or later
 - AIX 6.1, Technology Level 9, Service Pack 2, or later
- Linux
 - Red Hat Enterprise Linux Version 6.5, or later, with current maintenance updates available from Red Hat.
 - Red Hat Enterprise Linux Version 7, or later, with current maintenance updates available from Red Hat.
 - SUSE Linux Enterprise Server Version 12, or later
 - SUSE Linux Enterprise Server 11, Service Pack 3, or later, with current maintenance updates available from SUSE.
 - Ubuntu Server 14.04.3, or later

- For support details, see the Linux Alert website (www14.software.ibm.com/webapp/set2/sas/f/lopdiags/info/LinuxAlerts.html).
- IBM i
 - IBM i is supported only with VIOS

This adapter requires the following drivers:

- AIX: `devices.pciex.e4148a1614109304` for SFP+ optical ports and `devices.pciex.e4148a1614109404` for RJ45 ports
- Linux: `bnx2x` driver
- The latest version of the device driver or `iprutils` can be downloaded from the IBM Service and Productivity Tools website(<http://www14.software.ibm.com/webapp/set2/sas/f/lopdiags/home.html>).

Common procedures for servicing or installing features in the 8335-GCA or 8335-GTA

This section contains all the common procedures related to installing, removing, and replacing features in the IBM Power System S822LC (8335-GCA and 8335-GTA) system.

Before you begin

Observe these precautions when you are installing, removing, or replacing features and parts.

About this task

These precautions are intended to create a safe environment to service your system and do not provide steps for servicing your system. The installation, removal, and replacement procedures provide the step-by-step processes required to service your system.

DANGER: When working on or around the system, observe the following precautions:

Electrical voltage and current from power, telephone, and communication cables are hazardous. To avoid a shock hazard:

- If IBM supplied the power cord(s), connect power to this unit only with the IBM provided power cord. Do not use the IBM provided power cord for any other product.
- Do not open or service any power supply assembly.
- Do not connect or disconnect any cables or perform installation, maintenance, or reconfiguration of this product during an electrical storm.
- The product might be equipped with multiple power cords. To remove all hazardous voltages, disconnect all power cords.
 - For AC power, disconnect all power cords from their AC power source.
 - For racks with a DC power distribution panel (PDP), disconnect the customer's DC power source to the PDP.
- When connecting power to the product ensure all power cables are properly connected.
 - For racks with AC power, connect all power cords to a properly wired and grounded electrical outlet. Ensure that the outlet supplies proper voltage and phase rotation according to the system rating plate.
 - For racks with a DC power distribution panel (PDP), connect the customer's DC power source to the PDP. Ensure that the proper polarity is used when attaching the DC power and DC power return wiring.
- Connect any equipment that will be attached to this product to properly wired outlets.
- When possible, use one hand only to connect or disconnect signal cables.
- Never turn on any equipment when there is evidence of fire, water, or structural damage.
- Do not attempt to switch on power to the machine until all possible unsafe conditions are corrected.
- Assume that an electrical safety hazard is present. Perform all continuity, grounding, and power checks specified during the subsystem installation procedures to ensure that the machine meets safety requirements.
- Do not continue with the inspection if any unsafe conditions are present.
- Before you open the device covers, unless instructed otherwise in the installation and configuration procedures: Disconnect the attached AC power cords, turn off the applicable circuit breakers located in the rack power distribution panel (PDP), and disconnect any telecommunications systems, networks, and modems.

DANGER:

- Connect and disconnect cables as described in the following procedures when installing, moving, or opening covers on this product or attached devices.

To Disconnect:

1. Turn off everything (unless instructed otherwise).
2. For AC power, remove the power cords from the outlets.
3. For racks with a DC power distribution panel (PDP), turn off the circuit breakers located in the PDP and remove the power from the Customer's DC power source.
4. Remove the signal cables from the connectors.
5. Remove all cables from the devices.

To Connect:

1. Turn off everything (unless instructed otherwise).
2. Attach all cables to the devices.
3. Attach the signal cables to the connectors.
4. For AC power, attach the power cords to the outlets.
5. For racks with a DC power distribution panel (PDP), restore the power from the Customer's DC power source and turn on the circuit breakers located in the PDP.
6. Turn on the devices.

Sharp edges, corners and joints may be present in and around the system. Use care when handling equipment to avoid cuts, scrapes and pinching. (D005)

(R001 part 1 of 2):

DANGER: Observe the following precautions when working on or around your IT rack system:

- Heavy equipment—personal injury or equipment damage might result if mishandled.
- Always lower the leveling pads on the rack cabinet.
- Always install stabilizer brackets on the rack cabinet.
- To avoid hazardous conditions due to uneven mechanical loading, always install the heaviest devices in the bottom of the rack cabinet. Always install servers and optional devices starting from the bottom of the rack cabinet.
- Rack-mounted devices are not to be used as shelves or work spaces. Do not place objects on top of rack-mounted devices. In addition, do not lean on rack mounted devices and do not use them to stabilize your body position (for example, when working from a ladder).



- Each rack cabinet might have more than one power cord.
 - For AC powered racks, be sure to disconnect all power cords in the rack cabinet when directed to disconnect power during servicing.
 - For racks with a DC power distribution panel (PDP), turn off the circuit breaker that controls the power to the system unit(s), or disconnect the customer's DC power source, when directed to disconnect power during servicing.
- Connect all devices installed in a rack cabinet to power devices installed in the same rack cabinet. Do not plug a power cord from a device installed in one rack cabinet into a power device installed in a different rack cabinet.
- An electrical outlet that is not correctly wired could place hazardous voltage on the metal parts of the system or the devices that attach to the system. It is the responsibility of the customer to ensure that the outlet is correctly wired and grounded to prevent an electrical shock.

(R001 part 2 of 2):

CAUTION:

- Do not install a unit in a rack where the internal rack ambient temperatures will exceed the manufacturer's recommended ambient temperature for all your rack-mounted devices.

- Do not install a unit in a rack where the air flow is compromised. Ensure that air flow is not blocked or reduced on any side, front, or back of a unit used for air flow through the unit.
- Consideration should be given to the connection of the equipment to the supply circuit so that overloading of the circuits does not compromise the supply wiring or overcurrent protection. To provide the correct power connection to a rack, refer to the rating labels located on the equipment in the rack to determine the total power requirement of the supply circuit.
- (For sliding drawers.) Do not pull out or install any drawer or feature if the rack stabilizer brackets are not attached to the rack. Do not pull out more than one drawer at a time. The rack might become unstable if you pull out more than one drawer at a time.



- (For fixed drawers.) This drawer is a fixed drawer and must not be moved for servicing unless specified by the manufacturer. Attempting to move the drawer partially or completely out of the rack might cause the rack to become unstable or cause the drawer to fall out of the rack.

Before you begin a replacement or installation procedure, perform these tasks:

Procedure

1. If you are installing a new feature, ensure that you have the software required to support the new feature. See IBM Prerequisite.
2. If you are performing an installation or replacement procedure that might put your data at risk, ensure, wherever possible, that you have a current backup of your system or logical partition (including operating systems, licensed programs, and data).
3. Review the installation or replacement procedure for the feature or part.
4. Note the significance of color on your system.
Blue or terra-cotta on a part of the hardware indicates a touch point where you can grip the hardware to remove it from or install it in the system, open or close a latch, and so on. Terra-cotta might also indicate that the part can be removed and replaced with the system or logical partition power on.
5. Ensure that you have access to a medium flat-blade screwdriver, a Phillips screwdriver, and a pair of scissors.
6. If parts are incorrect, missing, or visibly damaged, do the following:
 - If you are replacing a part, contact the provider of your parts or next level of support.
 - If you are installing a feature, contact one of the following service organizations:
 - The provider of your parts or next level of support.
 - In the United States, the IBM Rochester Manufacturing Automated Information Line (R-MAIL) at 1-800-300-8751.

In countries and regions outside of the United States, use the following website to locate your service and support telephone numbers:
<http://www.ibm.com/planetwide>
7. If you encounter difficulties during the installation, contact your service provider, your IBM reseller, or your next level of support.

8. For the IBM Power System S822LC (8335-GCA and 8335-GTA) systems, ensure that the top cover is on when running for thermal performance.

Identifying the system that contains the part to replace

Learn how to determine which server or enclosure has the part you want to replace.

About this task

If the part does not have problem indicator LED, you will need to use a troubleshooting program such as **impitool** to identify the issue.

LEDs on the 8335-GCA or 8335-GTA system

Use this information as a guide to the LEDs on the IBM Power System S822LC (8335-GCA and 8335-GTA) system.

The LEDs indicate various system status. These LEDs are located at the front (as shown in Figure 63) and at the rear of the system.

- The green LED indicates the power status.
 - A constant light indicates full system power to the unit.
 - A flashing light indicates standby power to the unit.
 - It takes approximately 30-seconds from the time the power-on button is pressed to when the power LED changes from flashing to solid. During the transition period, the LED might flash faster.
- The amber LED indicates a problem in the system. After a part is repaired, the amber LED takes a minute to turn off.
- The blue LED is used to identify the system that requires service.

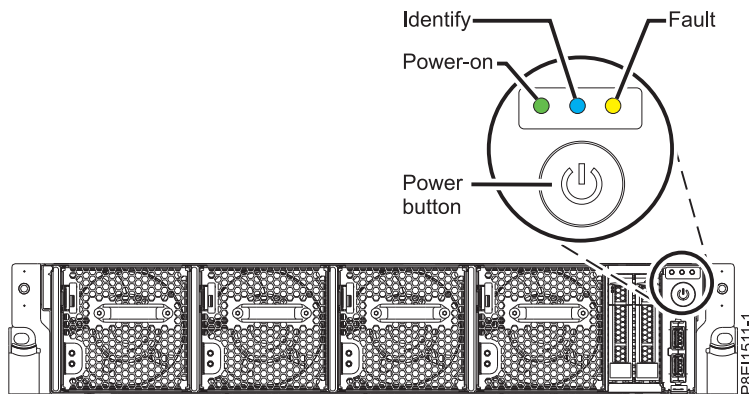

Figure 63. LEDs on an 8335-GCA or 8335-GTA system

LED indicators are located on the following parts:

- At the front of the system:
 - Disk drives (green LED indicates activity; amber LED indicates a problem)
 - Fans (green LED indicates activity; amber LED indicates a problem)
- At the rear of the system:
 - Backplane, near the rear LAN port: Green, amber, and blue (same as on the front next to the power button)
 - Power supplies (Two green LEDs indicate AC and DC power; amber LED indicates a problem)

Identifying the 8335-GCA or 8335-GTA that needs servicing

Use the Intelligent Platform Management Interface (IPMI) program to turn on the blue identify LED to help you find the system that needs servicing.

Procedure

Use the `ipmitool` command to activate the blue system identify LED.

For in-band networks, the chassis identify command is:

```
ipmitool -I <interface> chassis identify <interval>
```

Where:

interface

Is the interface you are using to connect to the system; for example `usb`.

interval

Is the time to turn on the identify LED in seconds. The default is 15; meaning the LED is on for 15 seconds then turns off. A value of zero (0) turns off the LED. A value of `force` turns on the LED and leaves it on until turned off.

To run the command remotely over the LAN, the chassis identify command to enter is:

```
ipmitool -I lanplus -H <hostname> -U <username> -P <password> chassis identify <interval>
```

Starting and stopping the 8335-GCA or 8335-GTA

Learn how to start and stop the IBM Power System S822LC (8335-GCA and 8335-GTA) system for performing a service action or system upgrade.

Starting the system

You use the power button to start the system.

About this task

Attention: For safety, airflow purposes and thermal performance, the service access cover must be installed and fully seated prior to powering the system on.

You can use this procedure to power on the system; or you can use a console and the IPMI tool to power on the system.

Procedure

1. Open the front rack door, if necessary.
2. Before you press the power button, ensure that the power supplies are connected to the system unit and verify the following items:
 - All system power cables are connected to a power source.
 - The Power-on LED, as shown in Figure 64 on page 94, is flashing. A flashing light indicates standby power to the unit.
3. Press the power button shown in Figure 64 on page 94. The power-on light stops flashing and remains on, indicating that the system power is on. The system cooling fans are operate at a high speed, and after approximately 30 seconds, return to operating speed.

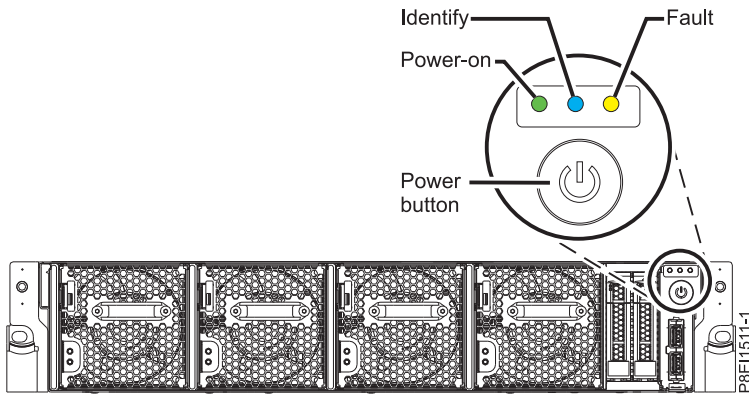

Figure 64. Power button

What to do next

If pressing the power button does not start the system, then contact your next level of support or your service provider.

Stopping the system

Learn how to stop the system to complete another task.

Procedure

You can use the Linux **shutdown** command to stop and power down the system. For example, the following command will shut down the system in 10 minutes and send the message “Repairs coming.” to the users.

```
shutdown -P +10 "Repairs coming."
```

The `-P` setting instructs the system to shut down and then power down. The `+` indicates the time in minutes before the shutdown occurs.

Event sensor status GUI display

The event sensor status GUI display is a way to quickly determine the general health status of the server without having to look at the detailed system event log (SEL) information.

To view the event sensor status GUI display, log in to the BMC web interface. The sensors and values appear on the first page (the dashboard).

Some occurrences of errors in the system might not appear in the event sensor GUI. After you view the event sensor status GUI display, use the SEL logs to view any active SEL events that indicate a service action event.

Event sensor status display operation

Most sensors are initially gray, then change status and color during the boot process when the FRU is initialized and either determined to be good (green) or faulty (red). No sensor display is available until you can get to the sensor display selection on the BMC, which means that the system attains a certain power level or that the BMC finishes initializing. The indicator color of the sensor is determined based on the sensor status at time of invocation of the display. The sensor display maintains the sensor status indicator color until the display is refreshed, which updates the sensor value with the latest status. Changes to SEL events changes color of sensor indicator when you refresh or restart the display. Sensor

status display also starts over with a reboot or a power cycle with a few exceptions, indicated in Table 22.

Event sensor status indicator descriptions

Gray indicator:

- FRU not plugged
- Sensor not initialized
- Sensor function is not initialized

Red (faulty) indicator:

- Critical threshold exceeded (an event requires a service action)
- Service action required for hard fail
- Partial function failure that reached a “service action required” state
- A deconfigured resource requires service action

Green (good) indicator:

- FRU or sensor is plugged in and fully operational
- Recoverable event is below the critical “service action required” threshold
- FRU or sensor returned to “normal” operating range (for threshold sensors)

Sensor state values during boot process

The key stages of operation.

Initial power on to BMC ready state

In this stage, some indicator values might not reflect the status of the physical sensor. In some instances, the state is not available because the sensor is not initialized; in this case, the sensor color is gray. In other cases (typically associated with Host Boot sensors), the value of the sensor shows the state when the system was operational. These sensors update to indicate the current status if the display is refreshed when the system reaches the Petitboot stage of operation. Table 22 shows the affected indicators.

BMC ready to PetitBoot or Host operation state

When the system reaches the Petitboot menu stage, and you refresh the display, all of the indicators reflect their operational state.

Table 22. Sensors and values during the stages of system operation

Sensor Name	Value at BMC Ready	Value at Petitboot or Later
Mem Buf Temp x (x = 0 - 7)	Not Available	Current
CPUx Temp (x = 0 - 1)	Not Available	Current
CPU Core Temp x (x = 0 - 23)	Not Available	Current
DIMMx Temp (x = 0 - 31)	Not Available	Current
GPU Temp x (x = 1 - 4)	Not Available	Current
CPU Diode x (x = 1 - 2)	Current	Current
Ambient Temp	Current	Current
CPU VDD Volt	Not Available	Current
CPU VDD Current	Not Available	Current
Fan x (x = 0 - 5)	Not Available	Current
Mem Buf Func x (X = 0 - 7)	From Previous IPL	Current
DIMM Func x (x = 0 - 31)	From Previous IPL	Current

Table 22. Sensors and values during the stages of system operation (continued)

Sensor Name	Value at BMC Ready	Value at Petitboot or Later
GPU Func x (x = 1 – 4)	Not Available	Current
CPU Core Func x (x = 0 – 23)	From Previous IPL	Current
CPU Func x (X = 0 – 1)	From Previous IPL	Current
Checkstop	Current	Current
Quick Power Drop	Current	Current
OCC x Active (x = 1 – 2)	Current	Current
PSU Fault x (x = 1 – 2)	Current	Current
All Pgood	Current	Current
FW Boot Progress	From Previous IPL	Current
Host Status	Current	Current
Watchdog	From Previous IPL	Current
System Event	From Previous IPL	Current
OS Boot	From Previous IPL	Current
PCI	From Previous IPL	Current
Mem ProcX Pwr (x = 0 – 3)	From Previous IPL	Current
Procx Power (x = 0 – 1)	From Previous IPL	Current
PCIE Procx Pwr (x = 0 – 1)	From Previous IPL	Current
Fan Power A (Fan Power)	From Previous IPL	Current
Mem Cache Power	From Previous IPL	Current
12V Sense	From Previous IPL	Current
GPU Sense (GPU Power)	From Previous IPL	Current
IO (A-B) Power	From Previous IPL	Current
Storage Power (A-B)	From Previous IPL	Current
Motherboard Flt	From Previous IPL	Current
Ref Clock Fault	From Previous IPL	Current
PCI Clock Fault	From Previous IPL	Current
TOD Clock Fault	From Previous IPL	Current
APSS Fault	From Previous IPL	Current
BMC Golden Side	Current	Current
BIOS Golden Side	Current	Current
Boot Count	Current	Current
Activate Pwr Lt	From Previous IPL	Current
PS Derating Fac	Current	Current
NxtPwr Redundant	Current	Current
CurPwr Redundant	Current	Current
System Power	Not Applicable	Current if applicable
Freq Limit OT x (x = 1 - 2)	Not Applicable	Current if applicable
Freq Limit Pwr x (x = 1 - 2)	Not Applicable	Current if applicable
CPU x VDD Temp (x = 1 - 2)	Not Applicable	Current if applicable

Removing and replacing covers on an 8335-GCA or 8335-GTA system

Learn how to remove and replace the covers for an IBM Power System S822LC (8335-GCA and 8335-GTA) system so that you can access the hardware parts or perform service.

Removing the service access cover from an 8335-GCA or 8335-GTA system

Learn how to remove the service access cover from an IBM Power System S822LC (8335-GCA and 8335-GTA) system.

Procedure

1. Remove the power supplies from the system. For instructions, see “Removing a power supply from the 8335-GCA or 8335-GTA” on page 107.
2. Release the cover by pressing the blue release latch (A).
3. While pressing down on latch (A) and touch point (B), slide the cover (C) toward the rear of the system unit. When the front of the service access cover clears the upper frame ledge, lift the cover up and off the system unit.

Attention: For proper cooling and airflow, replace the cover before powering on the system.

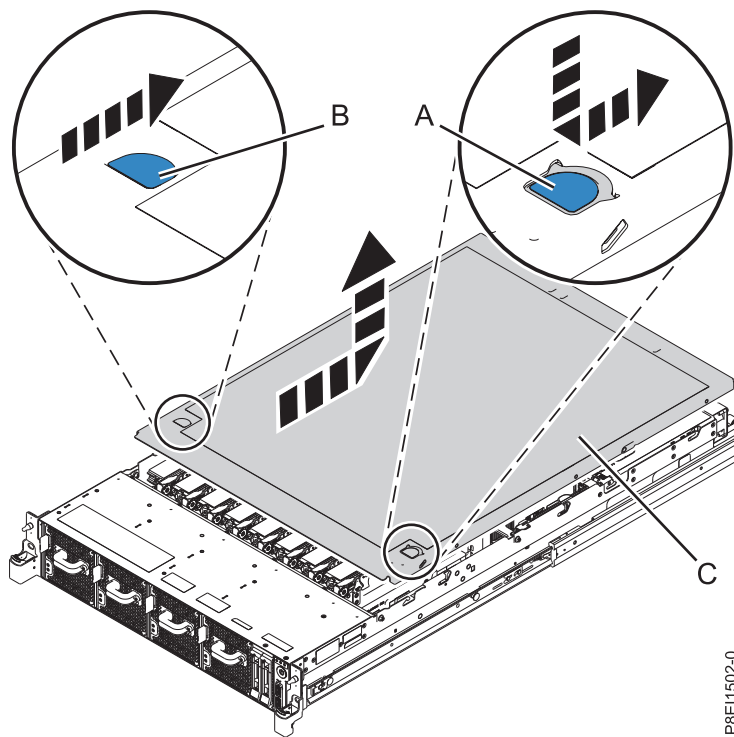

Figure 65. Removing the service access cover

Installing the service access cover on an 8335-GCA or 8335-GTA system

Learn how to install the service access cover on a rack-mounted IBM Power System S822LC (8335-GCA and 8335-GTA) system.

About this task

Attention: For safety, airflow purposes and thermal performance, the service access cover must be installed and fully seated prior to powering the system on.

Procedure

1. Place the cover (A) on to the system unit such that the alignment pins on the cover are aligned to the slots on the chassis.
2. Press down to engage the pins and slide the cover to the front of the system until the blue release latch (B) locks in to place, as shown in Figure 66.

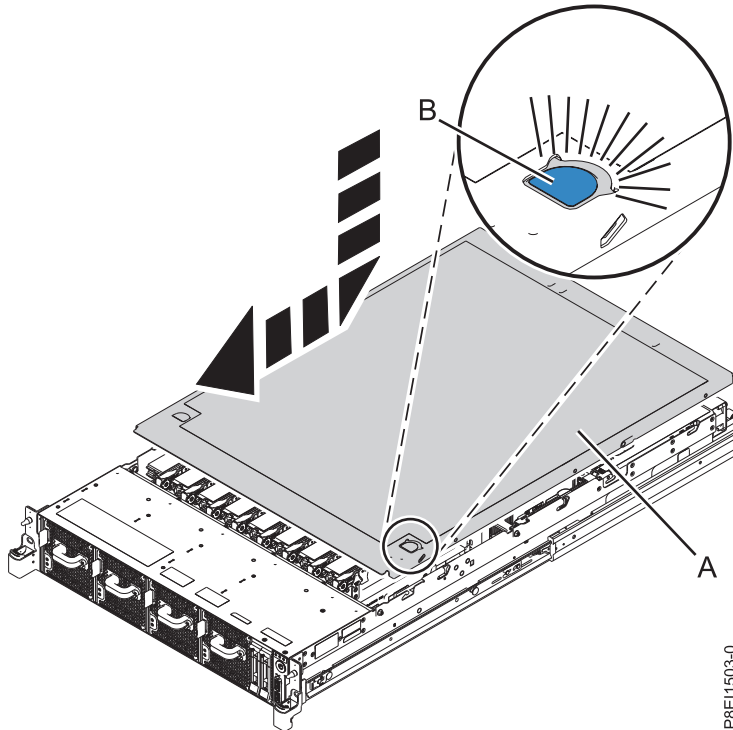

Figure 66. Installing the service access cover

3. Replace the power supplies into the chassis. For instructions, see “Replacing a power supply in the 8335-GCA or 8335-GTA” on page 108.

Service and operating positions for 8335-GCA or 8335-GTA

Learn how to place on an IBM Power System S822LC (8335-GCA and 8335-GTA) system into the service or operating position.

Placing an 8335-GCA or 8335-GTA system into the service position

Learn how to place an IBM Power System S822LC (8335-GCA and 8335-GTA) system into the service position.

About this task

Pick the proper type of rails for your system:

- “Slide rails” on page 99
- “Fixed rails” on page 99

Slide rails

Use this procedure when your system is installed using slide rails.

Before you begin

Notes:

- When placing the system into the service position, it is essential that all stability plates are firmly installed to prevent the rack from toppling. Ensure that only one system unit is in the service position at a time.
- Ensure that the cables at the rear of the system unit do not catch or bind as you pull the system unit forward in the rack.
- When the rails are fully extended, the rail safety latches lock into place. This action prevents the system from being pulled out too far.

Procedure

1. Remove the screws on either side of the system that secure the system to the rack.
2. Push down the front latches (A) that secure the system unit to the rack.

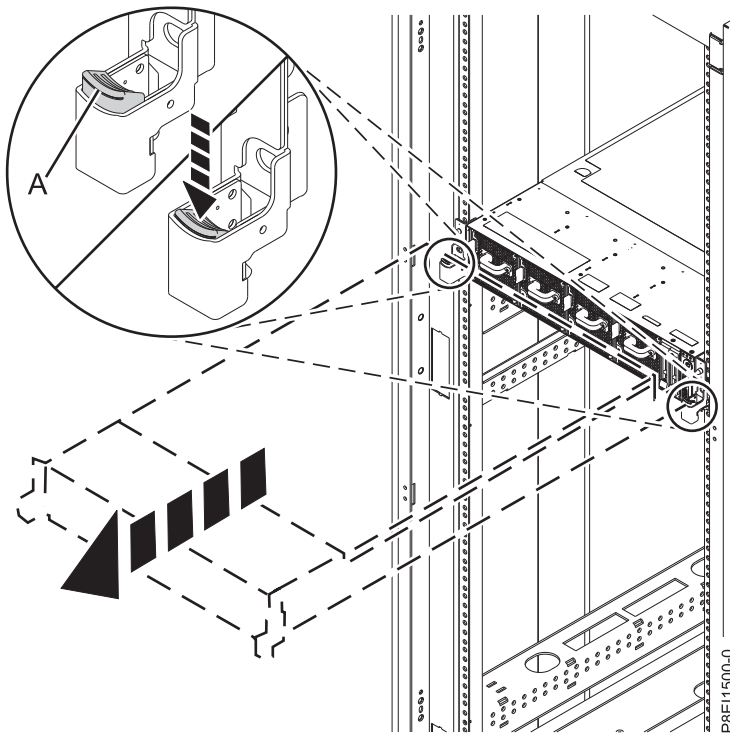

Figure 67. Placing the system into the service position

3. Pull the system unit out of the rack.

Fixed rails

Use this procedure when your system is installed using fixed rails.

Before you begin

CAUTION:

This system requires two people to remove the system from the rack. Do not begin this procedure unless physical assistance is available to remove the system from the rack.

Note: When placing the system into the service position, it is essential that all stability plates are firmly installed to prevent the rack from toppling. Ensure that only one system unit is removed at a time.

Procedure

1. Label and disconnect the cables at the rear of the system unit.
2. At the front, remove the screws on either side of the system that secure the system to the rack.
3. While one person is supporting the weight of the front of the system, have the second person move to the rear of the system and push the system partially out of the rack.
4. Position one person on the left side of the system and one person on the right side of the system.
5. Tilt and lift the system off of the rails.
6. Carefully set the system on a table with an appropriate ESD surface.

Placing an 8335-GCA or 8335-GTA system into the operating position

Learn how to place an IBM Power System S822LC (8335-GCA and 8335-GTA) system into the operating position.

About this task

Pick the proper type of rails for your system:

- “Slide rails”
- “Fixed rails” on page 101

Slide rails

Use this procedure when your system is installed using slide rails.

Before you begin

When you place the system in the operating position, ensure that the cables at the rear of the system do not catch or bind as you push the system unit back into the rack.

Procedure

1. Unlock the blue rail safety latches (**A**) by lifting them upward.
2. Align the system unit on to the rails and push the system unit back into the rack until both release latches lock into position.

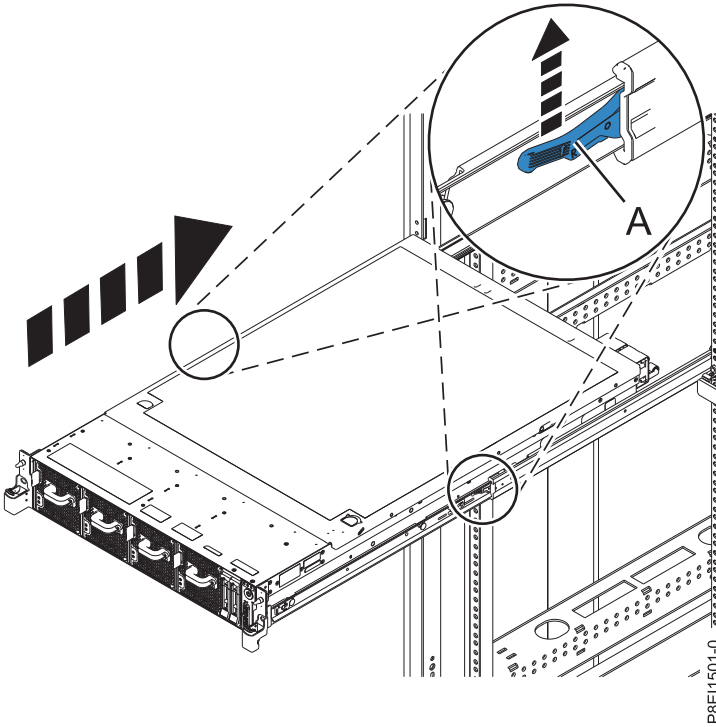

Figure 68. Placing the system into the operating position

3. Replace the screws on either side of the system that secure the system to the rack.

Fixed rails

Use this procedure when your system is installed using fixed rails.

Before you begin

CAUTION:

This system requires two people to replace the system into the rack. Do not begin this procedure unless physical assistance is available to replace the system into the rack.

Note: When placing the system into the operating position, it is essential that all stability plates are firmly installed to prevent the rack from toppling. Ensure that only one system unit is replaced at a time.

Procedure

1. Position one person on the left side of the system and one person on the right side of the system.
2. Lift the system.
3. Move the system into position over the front of the fixed rack rails.
4. Carefully lower the system until the rear of the system rests on the rails.
5. Push the system all the way into the rack.
6. Using your labels, reconnect the cables at the rear of the system unit.
7. At the front, replace the screws on either side of the system that secure the system to the rack.

Power cords

Learn how to disconnect and connect the power cords on IBM Power System S822LC (8335-GCA and 8335-GTA) systems.

Disconnecting the power cords from an 8335-GCA or 8335-GTA system

Learn how to disconnect the power cords from an IBM Power System S822LC (8335-GCA and 8335-GTA) system.

Procedure

1. Open the rear rack door on the system unit that you are servicing.
2. Identify the system unit that you are servicing in the rack.
3. Label and disconnect the power cords from the power supply handle. Unfasten the hook and loop fastener that ties the power cord to the power supply handle. Note how the power is looped; you will need to make that same loop when you reattach the power cords. There are two types of loops, detailed in Figure 69 and Figure 70 on page 103.

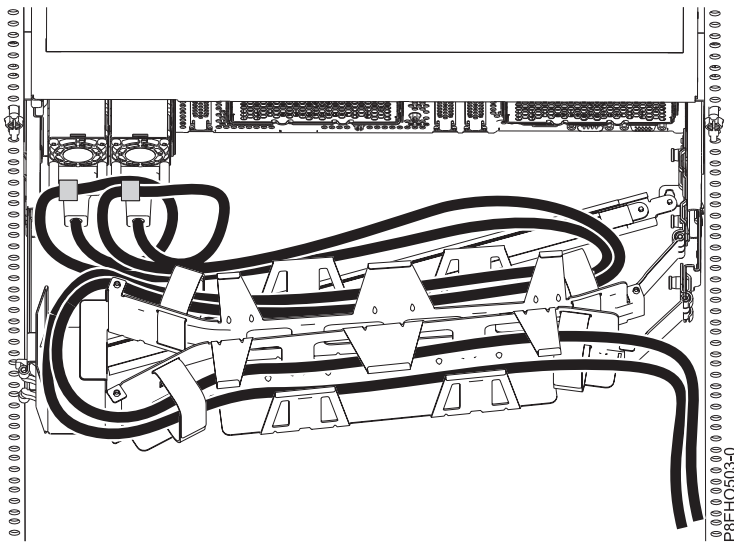

Figure 69. Power cord loop with cable management arm routing. The power cord loops counter-clockwise to the right.

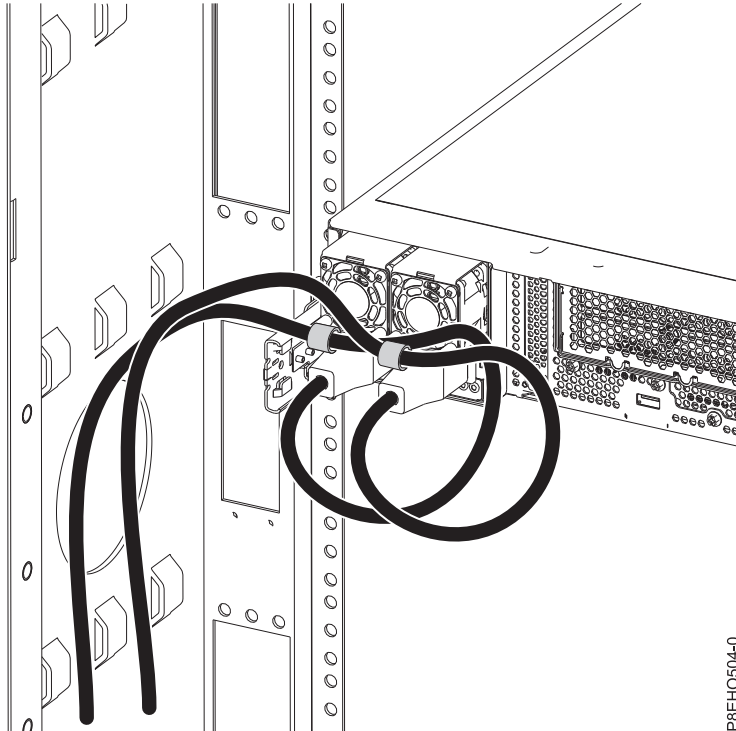

Figure 70. Power cord loop with sidewall routing. The power cord loops counter-clockwise to the left.

4. Disconnect the power cords from the system unit. See figure Figure 71.

Note: This system might be equipped with two or more power supplies. If the removing and replacing procedures require the power to be off, then ensure that all the power sources to the system have been completely disconnected.

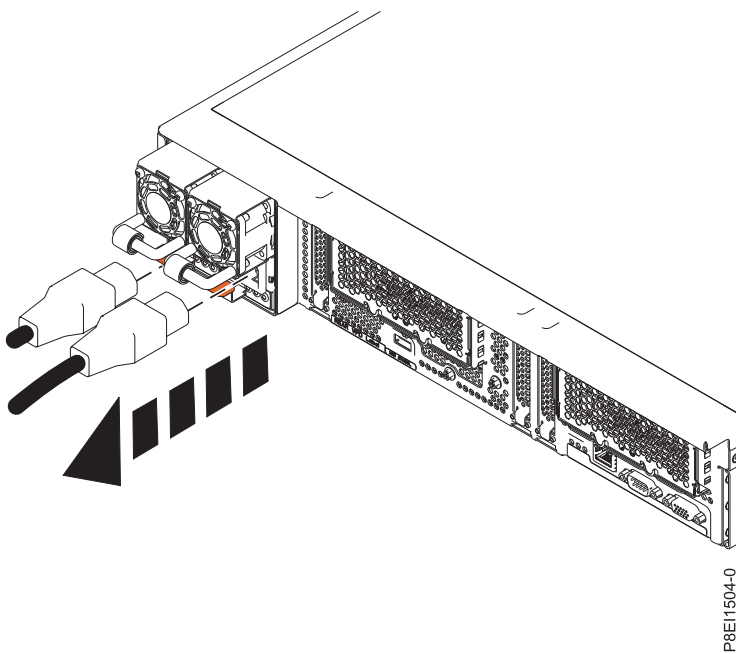

Figure 71. Removing the power cords from an 8335-GTA or 8335-GCA system

Connecting the power cords to an 8335-GCA or 8335-GTA system

Learn how to connect the power cords to an IBM Power System S822LC (8335-GCA and 8335-GTA) system.

Procedure

1. Open the rear rack door on the system unit that you are servicing.
2. Using your labels, reconnect the power cords to the system unit. See figure Figure 72.

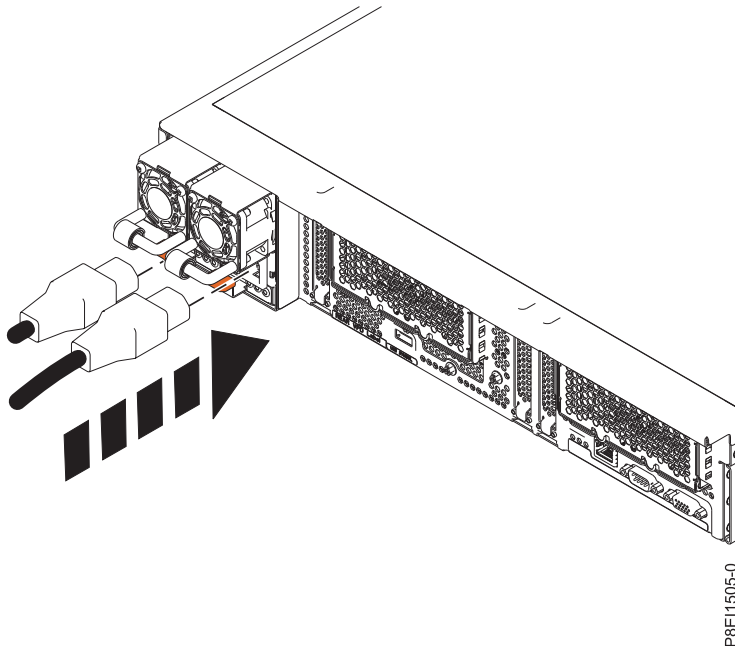

Figure 72. Connecting the power cords to an 8335-GTA or 8335-GCA system

3. Loop and attach the power cords to the power supply handle. Note how the power is looped; be sure to maintain at least a 5 cm (2 in.) diameter loop. There are two types of loops, detailed in Figure 73 on page 105 and Figure 74 on page 105. Use the hook-and-loop fastener to tie the power cord to the power supply handle.

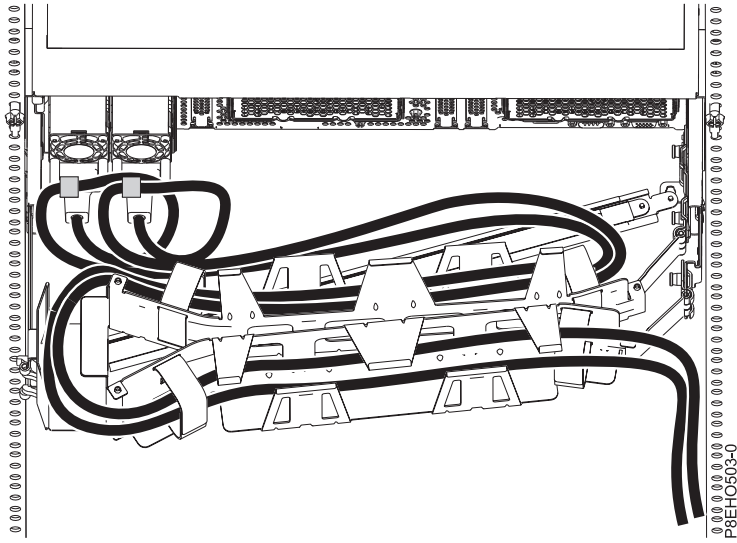

Figure 73. Power cord loop with cable management arm routing. The power cord loops counterclockwise to the right.

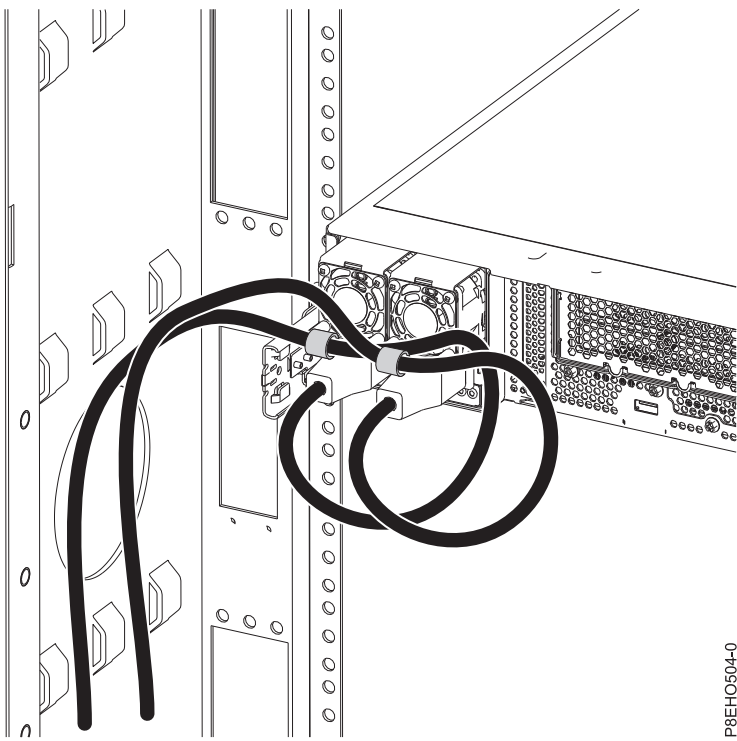

Figure 74. Power cord loop with sidewall routing. The power cord loops counterclockwise to the left.

4. Close the rack door at the rear of the system.

Removing and replacing a power supply in the 8335-GCA or 8335-GTA

Find information about removing and replacing power supplies in the IBM Power System S822LC (8335-GCA and 8335-GTA) system.

Removing a power supply from the 8335-GCA or 8335-GTA

To remove a power supply from the system, complete the steps in this procedure.

Procedure

1. Ensure that you have the electrostatic discharge (ESD) wrist strap attached. If not, attach it now.
2. Label and disconnect the power cord from the failed power supply.
Attention: Do not remove the power cord from the cable-management arm, if applicable.
 - a. Label the power cord, and then unstrap the hook-and-loop fastener to release the power cord from the power supply handle. Refer to Figure 75.
 - b. Pull the end of the power cord out of the power supply.
 - c. Retain the hook-and-loop fastener for future use.

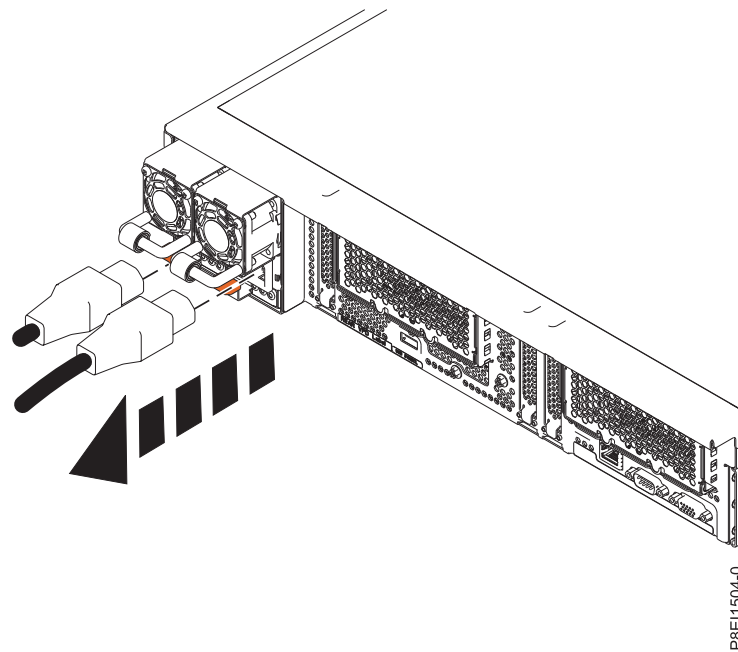

Figure 75. Disconnecting the power cord from the power supply

3. Remove the power supply from the system.
 - a. To unseat the power supply from its position in the system, pull up the terracotta locking-tab (A). See Figure 76 on page 108.
 - b. Grasp the power supply handle with one hand, and pull the power supply (B) part of the way out of the system.
 - c. Place your other hand underneath the power supply and pull the power supply completely out of the system and place it on an ESD mat.

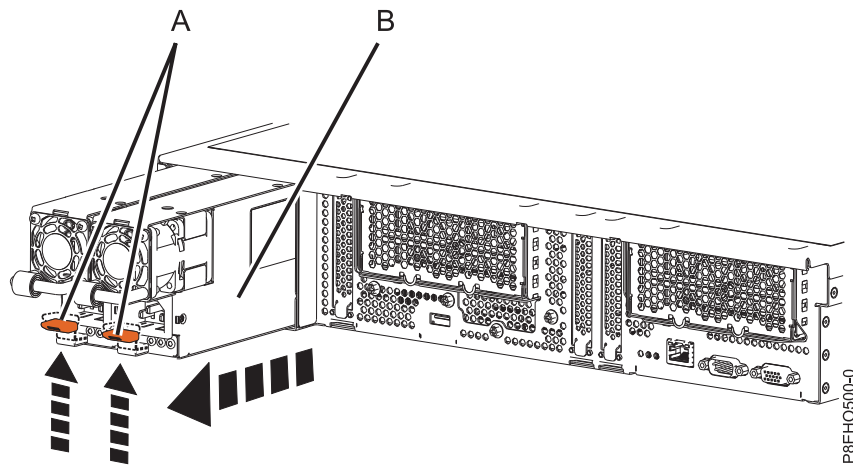

Figure 76. Removing a power supply from the system

Replacing a power supply in the 8335-GCA or 8335-GTA

To replace a power supply in the system, complete the steps in this procedure.

Procedure

1. Ensure that you have the electrostatic discharge (ESD) wrist strap attached. If not, attach it now.
2. Align the power supply (A) with the bay and slide the power supply into the system until the terracotta latch (B) locks in place. See Figure 77.

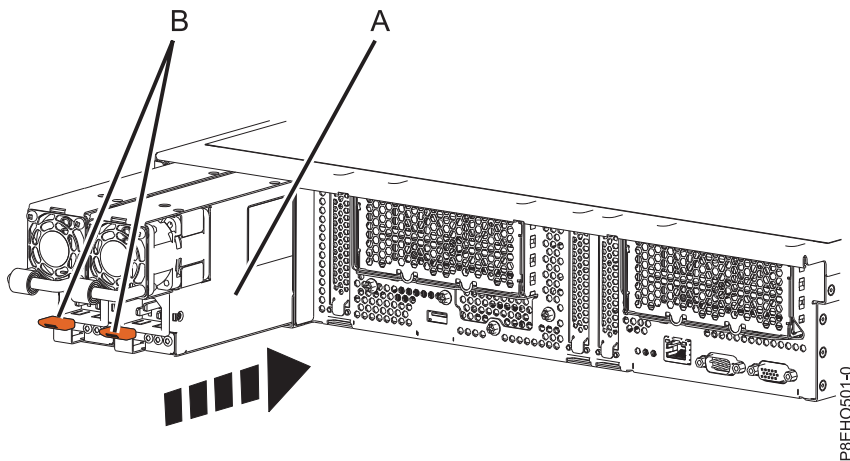

Figure 77. Replacing a power supply in the system

3. Connect and fasten the power cord to the power supply.
 - a. Connect the power cord to the power supply. See Figure 78 on page 109.
 - b. Use the hook-and-loop fastener and tie the power cord to the power supply handle. To properly loop the power cables, see “Connecting the power cords to an 8335-GCA or 8335-GTA system” on page 104

Attention: This system is equipped with two power supplies. Before you continue with this procedure, connect all power cords to the power supplies and strap them.

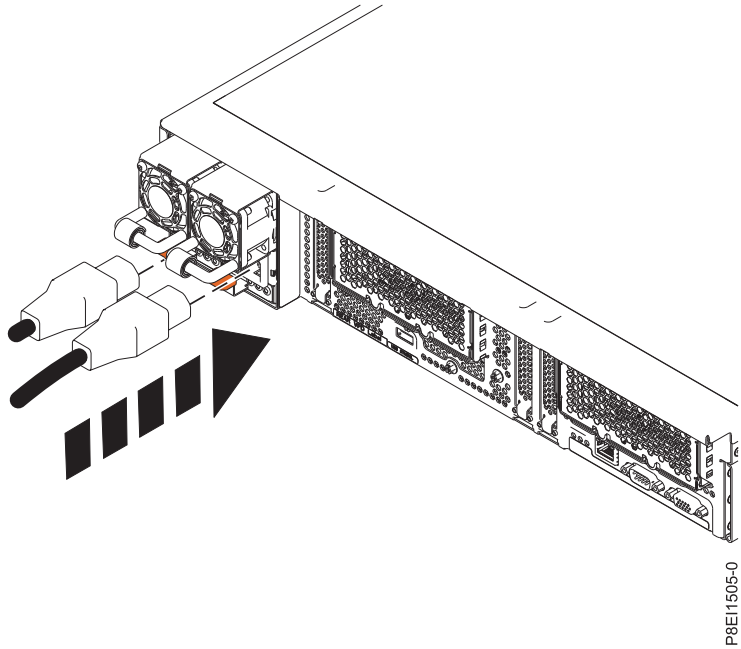

Figure 78. Connecting the power cord to the power supply

Notices

This information was developed for products and services offered in the US.

IBM may not offer the products, services, or features discussed in this document in other countries. Consult your local IBM representative for information on the products and services currently available in your area. Any reference to an IBM product, program, or service is not intended to state or imply that only that IBM product, program, or service may be used. Any functionally equivalent product, program, or service that does not infringe any IBM intellectual property right may be used instead. However, it is the user's responsibility to evaluate and verify the operation of any non-IBM product, program, or service.

IBM may have patents or pending patent applications covering subject matter described in this document. The furnishing of this document does not grant you any license to these patents. You can send license inquiries, in writing, to:

*IBM Director of Licensing
IBM Corporation
North Castle Drive, MD-NC119
Armonk, NY 10504-1785
US*

INTERNATIONAL BUSINESS MACHINES CORPORATION PROVIDES THIS PUBLICATION "AS IS" WITHOUT WARRANTY OF ANY KIND, EITHER EXPRESS OR IMPLIED, INCLUDING, BUT NOT LIMITED TO, THE IMPLIED WARRANTIES OF NON-INFRINGEMENT, MERCHANTABILITY OR FITNESS FOR A PARTICULAR PURPOSE. Some jurisdictions do not allow disclaimer of express or implied warranties in certain transactions, therefore, this statement may not apply to you.

This information could include technical inaccuracies or typographical errors. Changes are periodically made to the information herein; these changes will be incorporated in new editions of the publication. IBM may make improvements and/or changes in the product(s) and/or the program(s) described in this publication at any time without notice.

Any references in this information to non-IBM websites are provided for convenience only and do not in any manner serve as an endorsement of those websites. The materials at those websites are not part of the materials for this IBM product and use of those websites is at your own risk.

IBM may use or distribute any of the information you provide in any way it believes appropriate without incurring any obligation to you.

The performance data and client examples cited are presented for illustrative purposes only. Actual performance results may vary depending on specific configurations and operating conditions.

Information concerning non-IBM products was obtained from the suppliers of those products, their published announcements or other publicly available sources. IBM has not tested those products and cannot confirm the accuracy of performance, compatibility or any other claims related to non-IBM products. Questions on the capabilities of non-IBM products should be addressed to the suppliers of those products.

Statements regarding IBM's future direction or intent are subject to change or withdrawal without notice, and represent goals and objectives only.

All IBM prices shown are IBM's suggested retail prices, are current and are subject to change without notice. Dealer prices may vary.

This information is for planning purposes only. The information herein is subject to change before the products described become available.

This information contains examples of data and reports used in daily business operations. To illustrate them as completely as possible, the examples include the names of individuals, companies, brands, and products. All of these names are fictitious and any similarity to actual people or business enterprises is entirely coincidental.

If you are viewing this information in softcopy, the photographs and color illustrations may not appear.

The drawings and specifications contained herein shall not be reproduced in whole or in part without the written permission of IBM.

IBM has prepared this information for use with the specific machines indicated. IBM makes no representations that it is suitable for any other purpose.

IBM's computer systems contain mechanisms designed to reduce the possibility of undetected data corruption or loss. This risk, however, cannot be eliminated. Users who experience unplanned outages, system failures, power fluctuations or outages, or component failures must verify the accuracy of operations performed and data saved or transmitted by the system at or near the time of the outage or failure. In addition, users must establish procedures to ensure that there is independent data verification before relying on such data in sensitive or critical operations. Users should periodically check IBM's support websites for updated information and fixes applicable to the system and related software.

Homologation statement

This product may not be certified in your country for connection by any means whatsoever to interfaces of public telecommunications networks. Further certification may be required by law prior to making any such connection. Contact an IBM representative or reseller for any questions.

Accessibility features for IBM Power Systems servers

Accessibility features assist users who have a disability, such as restricted mobility or limited vision, to use information technology content successfully.

Overview

The IBM Power Systems servers include the following major accessibility features:

- Keyboard-only operation
- Operations that use a screen reader

The IBM Power Systems servers use the latest W3C Standard, WAI-ARIA 1.0 (www.w3.org/TR/wai-aria/), to ensure compliance with US Section 508 (www.access-board.gov/guidelines-and-standards/communications-and-it/about-the-section-508-standards/section-508-standards) and Web Content Accessibility Guidelines (WCAG) 2.0 (www.w3.org/TR/WCAG20/). To take advantage of accessibility features, use the latest release of your screen reader and the latest web browser that is supported by the IBM Power Systems servers.

The IBM Power Systems servers online product documentation in IBM Knowledge Center is enabled for accessibility. The accessibility features of IBM Knowledge Center are described in the Accessibility section of the IBM Knowledge Center help (www.ibm.com/support/knowledgcenter/doc/kc_help.html#accessibility).

Keyboard navigation

This product uses standard navigation keys.

Interface information

The IBM Power Systems servers user interfaces do not have content that flashes 2 - 55 times per second.

The IBM Power Systems servers web user interface relies on cascading style sheets to render content properly and to provide a usable experience. The application provides an equivalent way for low-vision users to use system display settings, including high-contrast mode. You can control font size by using the device or web browser settings.

The IBM Power Systems servers web user interface includes WAI-ARIA navigational landmarks that you can use to quickly navigate to functional areas in the application.

Vendor software

The IBM Power Systems servers include certain vendor software that is not covered under the IBM license agreement. IBM makes no representation about the accessibility features of these products. Contact the vendor for accessibility information about its products.

Related accessibility information

In addition to standard IBM help desk and support websites, IBM has a TTY telephone service for use by deaf or hard of hearing customers to access sales and support services:

TTY service
800-IBM-3383 (800-426-3383)
(within North America)

For more information about the commitment that IBM has to accessibility, see IBM Accessibility (www.ibm.com/able).

Privacy policy considerations

IBM Software products, including software as a service solutions, (“Software Offerings”) may use cookies or other technologies to collect product usage information, to help improve the end user experience, to tailor interactions with the end user, or for other purposes. In many cases no personally identifiable information is collected by the Software Offerings. Some of our Software Offerings can help enable you to collect personally identifiable information. If this Software Offering uses cookies to collect personally identifiable information, specific information about this offering’s use of cookies is set forth below.

This Software Offering does not use cookies or other technologies to collect personally identifiable information.

If the configurations deployed for this Software Offering provide you as the customer the ability to collect personally identifiable information from end users via cookies and other technologies, you should seek your own legal advice about any laws applicable to such data collection, including any requirements for notice and consent.

For more information about the use of various technologies, including cookies, for these purposes, see IBM’s Privacy Policy at <http://www.ibm.com/privacy> and IBM’s Online Privacy Statement at <http://www.ibm.com/privacy/details> the section entitled “Cookies, Web Beacons and Other Technologies” and the “IBM Software Products and Software-as-a-Service Privacy Statement” at <http://www.ibm.com/software/info/product-privacy>.

Trademarks

IBM, the IBM logo, and ibm.com are trademarks or registered trademarks of International Business Machines Corp., registered in many jurisdictions worldwide. Other product and service names might be trademarks of IBM or other companies. A current list of IBM trademarks is available on the web at Copyright and trademark information at www.ibm.com/legal/copytrade.shtml.

Intel, Intel logo, Intel Inside, Intel Inside logo, Intel Centrino, Intel Centrino logo, Celeron, Intel Xeon, Intel SpeedStep, Itanium, and Pentium are trademarks or registered trademarks of Intel Corporation or its subsidiaries in the United States and other countries.

Linux is a registered trademark of Linus Torvalds in the United States, other countries, or both.

Red Hat, the Red Hat "Shadow Man" logo, and all Red Hat-based trademarks and logos are trademarks or registered trademarks of Red Hat, Inc., in the United States and other countries.

Electronic emission notices

When attaching a monitor to the equipment, you must use the designated monitor cable and any interference suppression devices supplied with the monitor.

Class A Notices

The following Class A statements apply to the IBM servers that contain the POWER8 processor and its features unless designated as electromagnetic compatibility (EMC) Class B in the feature information.

Federal Communications Commission (FCC) Statement

Note: This equipment has been tested and found to comply with the limits for a Class A digital device, pursuant to Part 15 of the FCC Rules. These limits are designed to provide reasonable protection against harmful interference when the equipment is operated in a commercial environment. This equipment generates, uses, and can radiate radio frequency energy and, if not installed and used in accordance with the instruction manual, may cause harmful interference to radio communications. Operation of this equipment in a residential area is likely to cause harmful interference, in which case the user will be required to correct the interference at his own expense.

Properly shielded and grounded cables and connectors must be used in order to meet FCC emission limits. IBM is not responsible for any radio or television interference caused by using other than recommended cables and connectors or by unauthorized changes or modifications to this equipment. Unauthorized changes or modifications could void the user's authority to operate the equipment.

This device complies with Part 15 of the FCC rules. Operation is subject to the following two conditions: (1) this device may not cause harmful interference, and (2) this device must accept any interference received, including interference that may cause undesired operation.

Industry Canada Compliance Statement

CAN ICES-3 (A)/NMB-3(A)

European Community Compliance Statement

This product is in conformity with the protection requirements of EU Council Directive 2014/30/EU on the approximation of the laws of the Member States relating to electromagnetic compatibility. IBM cannot accept responsibility for any failure to satisfy the protection requirements resulting from a non-recommended modification of the product, including the fitting of non-IBM option cards.

European Community contact:
IBM Deutschland GmbH
Technical Regulations, Abteilung M456
IBM-Allee 1, 71139 Ehningen, Germany
Tel: +49 800 225 5426
email: halloibm@de.ibm.com

Warning: This is a Class A product. In a domestic environment, this product may cause radio interference, in which case the user may be required to take adequate measures.

VCCI Statement - Japan

この装置は、クラスA 情報技術装置です。この装置を家庭環境で使用すると電波妨害を引き起こすことがあります。この場合には使用者が適切な対策を講ずるよう要求されることがあります。 VCCI-A

The following is a summary of the VCCI Japanese statement in the box above:

This is a Class A product based on the standard of the VCCI Council. If this equipment is used in a domestic environment, radio interference may occur, in which case, the user may be required to take corrective actions.

Japan Electronics and Information Technology Industries Association Statement

This statement explains the Japan JIS C 61000-3-2 product wattage compliance.

(一社) 電子情報技術産業協会 高調波電流抑制対策実施
要領に基づく定格入力電力値： Knowledge Centerの各製品の
仕様ページ参照

This statement explains the Japan Electronics and Information Technology Industries Association (JEITA) statement for products less than or equal to 20 A per phase.

高調波電流規格 JIS C 61000-3-2 適合品

This statement explains the JEITA statement for products greater than 20 A, single phase.

高調波電流規格 JIS C 61000-3-2 準用品

本装置は、「高圧又は特別高圧で受電する需要家の高調波抑制対策ガイドライン」対象機器（高調波発生機器）です。

- 回路分類 : 6 (単相、PFC回路付)
- 換算係数 : 0

This statement explains the JEITA statement for products greater than 20 A per phase, three-phase.

高調波電流規格 JIS C 61000-3-2 準用品

本装置は、「高圧又は特別高圧で受電する需要家の高調波抑制対策ガイドライン」対象機器（高調波発生機器）です。

- 回路分類 : 5 (3相、PFC回路付)
- 換算係数 : 0

Electromagnetic Interference (EMI) Statement - People's Republic of China

声 明

此为 A 级产品,在生活环境中,该产品可能会造成无线电干扰。在这种情况下,可能需要用户对其干扰采取切实可行的措施。

Declaration: This is a Class A product. In a domestic environment this product may cause radio interference in which case the user may need to perform practical action.

Electromagnetic Interference (EMI) Statement - Taiwan

警告使用者：

這是甲類的資訊產品，在居住的環境中使用時，可能會造成射頻干擾，在這種情況下，使用者會被要求採取某些適當的對策。

The following is a summary of the EMI Taiwan statement above.

Warning: This is a Class A product. In a domestic environment this product may cause radio interference in which case the user will be required to take adequate measures.

IBM Taiwan Contact Information:

台灣IBM 產品服務聯絡方式：
台灣國際商業機器股份有限公司
台北市松仁路7號3樓
電話：0800-016-888

Electromagnetic Interference (EMI) Statement - Korea

이 기기는 업무용 환경에서 사용할 목적으로 적합성평가를 받은 기기로서 가정용 환경에서 사용하는 경우 전파간섭의 우려가 있습니다.

Germany Compliance Statement

Deutschsprachiger EU Hinweis: Hinweis für Geräte der Klasse A EU-Richtlinie zur Elektromagnetischen Verträglichkeit

Dieses Produkt entspricht den Schutzanforderungen der EU-Richtlinie 2014/30/EU zur Angleichung der Rechtsvorschriften über die elektromagnetische Verträglichkeit in den EU-Mitgliedsstaaten und hält die Grenzwerte der EN 55022 / EN 55032 Klasse A ein.

Um dieses sicherzustellen, sind die Geräte wie in den Handbüchern beschrieben zu installieren und zu betreiben. Des Weiteren dürfen auch nur von der IBM empfohlene Kabel angeschlossen werden. IBM übernimmt keine Verantwortung für die Einhaltung der Schutzanforderungen, wenn das Produkt ohne Zustimmung von IBM verändert bzw. wenn Erweiterungskomponenten von Fremdherstellern ohne Empfehlung von IBM gesteckt/eingebaut werden.

EN 55022 / EN 55032 Klasse A Geräte müssen mit folgendem Warnhinweis versehen werden:
"Warnung: Dieses ist eine Einrichtung der Klasse A. Diese Einrichtung kann im Wohnbereich Funk-Störungen verursachen; in diesem Fall kann vom Betreiber verlangt werden, angemessene Maßnahmen zu ergreifen und dafür aufzukommen."

Deutschland: Einhaltung des Gesetzes über die elektromagnetische Verträglichkeit von Geräten

Dieses Produkt entspricht dem "Gesetz über die elektromagnetische Verträglichkeit von Geräten (EMVG)". Dies ist die Umsetzung der EU-Richtlinie 2014/30/EU in der Bundesrepublik Deutschland.

Zulassungsbescheinigung laut dem Deutschen Gesetz über die elektromagnetische Verträglichkeit von Geräten (EMVG) (bzw. der EMC Richtlinie 2014/30/EU) für Geräte der Klasse A

Dieses Gerät ist berechtigt, in Übereinstimmung mit dem Deutschen EMVG das EG-Konformitätszeichen - CE - zu führen.

Verantwortlich für die Einhaltung der EMV Vorschriften ist der Hersteller:
International Business Machines Corp.
New Orchard Road

Armonk, New York 10504
Tel: 914-499-1900

Der verantwortliche Ansprechpartner des Herstellers in der EU ist:
IBM Deutschland GmbH
Technical Relations Europe, Abteilung M456
IBM-Allee 1, 71139 Ehningen, Germany
Tel: +49 (0) 800 225 5426
email: HalloIBM@de.ibm.com

Generelle Informationen:

Das Gerät erfüllt die Schutzanforderungen nach EN 55024 und EN 55022 / EN 55032 Klasse A.

Electromagnetic Interference (EMI) Statement - Russia

ВНИМАНИЕ! Настоящее изделие относится к классу А.
В жилых помещениях оно может создавать
радиопомехи, для снижения которых необходимы
дополнительные меры

Class B Notices

The following Class B statements apply to features designated as electromagnetic compatibility (EMC) Class B in the feature installation information.

Federal Communications Commission (FCC) Statement

This equipment has been tested and found to comply with the limits for a Class B digital device, pursuant to Part 15 of the FCC Rules. These limits are designed to provide reasonable protection against harmful interference in a residential installation.

This equipment generates, uses, and can radiate radio frequency energy and, if not installed and used in accordance with the instructions, may cause harmful interference to radio communications. However, there is no guarantee that interference will not occur in a particular installation.

If this equipment does cause harmful interference to radio or television reception, which can be determined by turning the equipment off and on, the user is encouraged to try to correct the interference by one or more of the following measures:

- Reorient or relocate the receiving antenna.
- Increase the separation between the equipment and receiver.
- Connect the equipment into an outlet on a circuit different from that to which the receiver is connected.
- Consult an IBM-authorized dealer or service representative for help.

Properly shielded and grounded cables and connectors must be used in order to meet FCC emission limits. Proper cables and connectors are available from IBM-authorized dealers. IBM is not responsible for any radio or television interference caused by unauthorized changes or modifications to this equipment. Unauthorized changes or modifications could void the user's authority to operate this equipment.

This device complies with Part 15 of the FCC rules. Operation is subject to the following two conditions: (1) this device may not cause harmful interference, and (2) this device must accept any interference received, including interference that may cause undesired operation.

Industry Canada Compliance Statement

CAN ICES-3 (B)/NMB-3(B)

European Community Compliance Statement

This product is in conformity with the protection requirements of EU Council Directive 2014/30/EU on the approximation of the laws of the Member States relating to electromagnetic compatibility. IBM cannot accept responsibility for any failure to satisfy the protection requirements resulting from a non-recommended modification of the product, including the fitting of non-IBM option cards.

European Community contact:
IBM Deutschland GmbH
Technical Regulations, Abteilung M456
IBM-Allee 1, 71139 Ehningen, Germany
Tel: +49 800 225 5426
email: halloibm@de.ibm.com

VCCI Statement - Japan

この装置は、クラスB情報技術装置です。この装置は、家庭環境で使用することを目的としていますが、この装置がラジオやテレビジョン受信機に近接して使用されると、受信障害を引き起こすことがあります。

取扱説明書に従って正しい取り扱いをして下さい。 VCCI-B

Japan Electronics and Information Technology Industries Association Statement

This statement explains the Japan JIS C 61000-3-2 product wattage compliance.

(一社) 電子情報技術産業協会 高調波電流抑制対策実施
要領に基づく定格入力電力値 : Knowledge Centerの各製品の
仕様ページ参照

This statement explains the Japan Electronics and Information Technology Industries Association (JEITA) statement for products less than or equal to 20 A per phase.

高調波電流規格 JIS C 61000-3-2 適合品

This statement explains the JEITA statement for products greater than 20 A, single phase.

高調波電流規格 JIS C 61000-3-2 準用品

本装置は、「高圧又は特別高圧で受電する需要家の高調波抑制対策ガイドライン」対象機器（高調波発生機器）です。

- 回路分類 : 6 (単相、PFC回路付)
- 換算係数 : 0

This statement explains the JEITA statement for products greater than 20 A per phase, three-phase.

高調波電流規格 JIS C 61000-3-2 準用品

本装置は、「高圧又は特別高圧で受電する需要家の高調波抑制対策ガイドライン」対象機器（高調波発生機器）です。

- 回路分類 : 5 (3相、PFC回路付)
- 換算係数 : 0

IBM Taiwan Contact Information

台灣IBM 產品服務聯絡方式：
台灣國際商業機器股份有限公司
台北市松仁路7號3樓
電話：0800-016-888

Germany Compliance Statement

Deutschsprachiger EU Hinweis: Hinweis für Geräte der Klasse B EU-Richtlinie zur Elektromagnetischen Verträglichkeit

Dieses Produkt entspricht den Schutzanforderungen der EU-Richtlinie 2014/30/EU zur Angleichung der Rechtsvorschriften über die elektromagnetische Verträglichkeit in den EU-Mitgliedsstaaten und hält die Grenzwerte der EN 55022/ EN 55032 Klasse B ein.

Um dieses sicherzustellen, sind die Geräte wie in den Handbüchern beschrieben zu installieren und zu betreiben. Des Weiteren dürfen auch nur von der IBM empfohlene Kabel angeschlossen werden. IBM übernimmt keine Verantwortung für die Einhaltung der Schutzanforderungen, wenn das Produkt ohne Zustimmung von IBM verändert bzw. wenn Erweiterungskomponenten von Fremdherstellern ohne Empfehlung von IBM gesteckt/eingebaut werden.

Deutschland: Einhaltung des Gesetzes über die elektromagnetische Verträglichkeit von Geräten

Dieses Produkt entspricht dem "Gesetz über die elektromagnetische Verträglichkeit von Geräten (EMVG)". Dies ist die Umsetzung der EU-Richtlinie 2014/30/EU in der Bundesrepublik Deutschland.

Zulassungsbescheinigung laut dem Deutschen Gesetz über die elektromagnetische Verträglichkeit von Geräten (EMVG) (bzw. der EMC Richtlinie 2014/30/EU) für Geräte der Klasse B

Dieses Gerät ist berechtigt, in Übereinstimmung mit dem Deutschen EMVG das EG-Konformitätszeichen - CE - zu führen.

Verantwortlich für die Einhaltung der EMV Vorschriften ist der Hersteller:
International Business Machines Corp.
New Orchard Road
Armonk, New York 10504
Tel: 914-499-1900

Der verantwortliche Ansprechpartner des Herstellers in der EU ist:
IBM Deutschland GmbH
Technical Relations Europe, Abteilung M456
IBM-Allee 1, 71139 Ehningen, Germany
Tel: +49 (0) 800 225 5426
email: HalloIBM@de.ibm.com

Generelle Informationen:

Das Gerät erfüllt die Schutzanforderungen nach EN 55024 und EN 55022/ EN 55032 Klasse B.

Terms and conditions

Permissions for the use of these publications are granted subject to the following terms and conditions.

Applicability: These terms and conditions are in addition to any terms of use for the IBM website.

Personal Use: You may reproduce these publications for your personal, noncommercial use provided that all proprietary notices are preserved. You may not distribute, display or make derivative works of these publications, or any portion thereof, without the express consent of IBM.

Commercial Use: You may reproduce, distribute and display these publications solely within your enterprise provided that all proprietary notices are preserved. You may not make derivative works of these publications, or reproduce, distribute or display these publications or any portion thereof outside your enterprise, without the express consent of IBM.

Rights: Except as expressly granted in this permission, no other permissions, licenses or rights are granted, either express or implied, to the publications or any information, data, software or other intellectual property contained therein.

IBM reserves the right to withdraw the permissions granted herein whenever, in its discretion, the use of the publications is detrimental to its interest or, as determined by IBM, the above instructions are not being properly followed.

You may not download, export or re-export this information except in full compliance with all applicable laws and regulations, including all United States export laws and regulations.

IBM MAKES NO GUARANTEE ABOUT THE CONTENT OF THESE PUBLICATIONS. THE PUBLICATIONS ARE PROVIDED "AS-IS" AND WITHOUT WARRANTY OF ANY KIND, EITHER EXPRESSED OR IMPLIED, INCLUDING BUT NOT LIMITED TO IMPLIED WARRANTIES OF MERCHANTABILITY, NON-INFRINGEMENT, AND FITNESS FOR A PARTICULAR PURPOSE.



Printed in USA