

Power Systems

*Installing the IBM Power System E850
(8408-E8E)*

IBM

Power Systems

*Installing the IBM Power System E850
(8408-E8E)*



Note

Before using this information and the product it supports, read the information in “Safety notices” on page v, “Notices” on page 39, the *IBM Systems Safety Notices* manual, G229-9054, and the *IBM Environmental Notices and User Guide*, Z125-5823.

This edition applies to IBM Power Systems™ servers that contain the POWER8 processor and to all associated models.

© Copyright IBM Corporation 2015, 2017.

US Government Users Restricted Rights – Use, duplication or disclosure restricted by GSA ADP Schedule Contract with IBM Corp.

Contents

Safety notices	v
Installing the IBM Power System E850 (8408-E8E)	1
Prerequisite for installing the IBM Power System E850 (8408-E8E)	1
Completing inventory for your server	1
Attaching the lift handles to the chassis	2
Installing the server into a rack	3
Attaching the mounting hardware to the rack	3
Removing components from the system chassis.	6
Removing the power supplies	7
Removing the front cover	7
Removing the system fans	8
Removing the disk drive backplane.	9
Attaching the lift handles to the chassis	11
Installing the system into the rack	11
Replacing components into the system chassis.	13
Replacing the disk drive backplane	13
Replacing the system fans	14
Replacing the front cover.	15
Replacing the power supplies	16
Installing the cable-management arm	17
Cabling the server and setting up a console	19
Determining which console to use	19
Cabling the server with an ASCII terminal	20
Cabling the server to the HMC	21
Cabling the server and accessing the IVM	22
Cabling the server with keyboard, video, and mouse	23
Cabling the server and connecting expansion units	24
Completing the server setup	24
Completing the server setup by using an HMC	24
Completing the server setup without using an HMC	26
Setting up a preinstalled server	27
Preparing to set up your preinstalled server	27
Completing inventory for your preinstalled server	28
Removing the shipping bracket and connecting power cords and power distribution unit (PDU) for your preinstalled server	29
Cabling the server and setting up a console	30
Determining which console to use	30
Cabling the server with an ASCII terminal	31
Cabling the server to the HMC	32
Cabling the server and accessing the IVM	33
Cabling the server with keyboard, video, and mouse	34
Routing cables through the cable-management arm and connecting expansion units	34
Completing the server setup	34
Completing the server setup by using an HMC	35
Completing the server setup without using an HMC	37
Notices	39
Accessibility features for IBM Power Systems servers	40
Privacy policy considerations	41
Trademarks	42
Electronic emission notices	42
Class A Notices	42
Class B Notices	46
Terms and conditions	49

Safety notices

Safety notices may be printed throughout this guide:

- **DANGER** notices call attention to a situation that is potentially lethal or extremely hazardous to people.
- **CAUTION** notices call attention to a situation that is potentially hazardous to people because of some existing condition.
- **Attention** notices call attention to the possibility of damage to a program, device, system, or data.

World Trade safety information

Several countries require the safety information contained in product publications to be presented in their national languages. If this requirement applies to your country, safety information documentation is included in the publications package (such as in printed documentation, on DVD, or as part of the product) shipped with the product. The documentation contains the safety information in your national language with references to the U.S. English source. Before using a U.S. English publication to install, operate, or service this product, you must first become familiar with the related safety information documentation. You should also refer to the safety information documentation any time you do not clearly understand any safety information in the U.S. English publications.

Replacement or additional copies of safety information documentation can be obtained by calling the IBM Hotline at 1-800-300-8751.

German safety information

Das Produkt ist nicht für den Einsatz an Bildschirmarbeitsplätzen im Sinne § 2 der Bildschirmarbeitsverordnung geeignet.

Laser safety information

IBM® servers can use I/O cards or features that are fiber-optic based and that utilize lasers or LEDs.

Laser compliance

IBM servers may be installed inside or outside of an IT equipment rack.

DANGER: When working on or around the system, observe the following precautions:

Electrical voltage and current from power, telephone, and communication cables are hazardous. To avoid a shock hazard:

- If IBM supplied the power cord(s), connect power to this unit only with the IBM provided power cord. Do not use the IBM provided power cord for any other product.
- Do not open or service any power supply assembly.
- Do not connect or disconnect any cables or perform installation, maintenance, or reconfiguration of this product during an electrical storm.
- The product might be equipped with multiple power cords. To remove all hazardous voltages, disconnect all power cords.
 - For AC power, disconnect all power cords from their AC power source.
 - For racks with a DC power distribution panel (PDP), disconnect the customer's DC power source to the PDP.
- When connecting power to the product ensure all power cables are properly connected.

- For racks with AC power, connect all power cords to a properly wired and grounded electrical outlet. Ensure that the outlet supplies proper voltage and phase rotation according to the system rating plate.
- For racks with a DC power distribution panel (PDP), connect the customer's DC power source to the PDP. Ensure that the proper polarity is used when attaching the DC power and DC power return wiring.
- Connect any equipment that will be attached to this product to properly wired outlets.
- When possible, use one hand only to connect or disconnect signal cables.
- Never turn on any equipment when there is evidence of fire, water, or structural damage.
- Do not attempt to switch on power to the machine until all possible unsafe conditions are corrected.
- Assume that an electrical safety hazard is present. Perform all continuity, grounding, and power checks specified during the subsystem installation procedures to ensure that the machine meets safety requirements.
- Do not continue with the inspection if any unsafe conditions are present.
- Before you open the device covers, unless instructed otherwise in the installation and configuration procedures: Disconnect the attached AC power cords, turn off the applicable circuit breakers located in the rack power distribution panel (PDP), and disconnect any telecommunications systems, networks, and modems.

DANGER:

- Connect and disconnect cables as described in the following procedures when installing, moving, or opening covers on this product or attached devices.

To Disconnect:

1. Turn off everything (unless instructed otherwise).
2. For AC power, remove the power cords from the outlets.
3. For racks with a DC power distribution panel (PDP), turn off the circuit breakers located in the PDP and remove the power from the Customer's DC power source.
4. Remove the signal cables from the connectors.
5. Remove all cables from the devices.

To Connect:

1. Turn off everything (unless instructed otherwise).
2. Attach all cables to the devices.
3. Attach the signal cables to the connectors.
4. For AC power, attach the power cords to the outlets.
5. For racks with a DC power distribution panel (PDP), restore the power from the Customer's DC power source and turn on the circuit breakers located in the PDP.
6. Turn on the devices.

Sharp edges, corners and joints may be present in and around the system. Use care when handling equipment to avoid cuts, scrapes and pinching. (D005)

(R001 part 1 of 2):

DANGER: Observe the following precautions when working on or around your IT rack system:

- Heavy equipment—personal injury or equipment damage might result if mishandled.
- Always lower the leveling pads on the rack cabinet.
- Always install stabilizer brackets on the rack cabinet.
- To avoid hazardous conditions due to uneven mechanical loading, always install the heaviest devices in the bottom of the rack cabinet. Always install servers and optional devices starting from the bottom of the rack cabinet.
- Rack-mounted devices are not to be used as shelves or work spaces. Do not place objects on top of rack-mounted devices. In addition, do not lean on rack mounted devices and do not use them to stabilize your body position (for example, when working from a ladder).



- Each rack cabinet might have more than one power cord.
 - For AC powered racks, be sure to disconnect all power cords in the rack cabinet when directed to disconnect power during servicing.
 - For racks with a DC power distribution panel (PDP), turn off the circuit breaker that controls the power to the system unit(s), or disconnect the customer's DC power source, when directed to disconnect power during servicing.
- Connect all devices installed in a rack cabinet to power devices installed in the same rack cabinet. Do not plug a power cord from a device installed in one rack cabinet into a power device installed in a different rack cabinet.
- An electrical outlet that is not correctly wired could place hazardous voltage on the metal parts of the system or the devices that attach to the system. It is the responsibility of the customer to ensure that the outlet is correctly wired and grounded to prevent an electrical shock.

(R001 part 2 of 2):

CAUTION:

- Do not install a unit in a rack where the internal rack ambient temperatures will exceed the manufacturer's recommended ambient temperature for all your rack-mounted devices.
- Do not install a unit in a rack where the air flow is compromised. Ensure that air flow is not blocked or reduced on any side, front, or back of a unit used for air flow through the unit.
- Consideration should be given to the connection of the equipment to the supply circuit so that overloading of the circuits does not compromise the supply wiring or overcurrent protection. To provide the correct power connection to a rack, refer to the rating labels located on the equipment in the rack to determine the total power requirement of the supply circuit.
- (*For sliding drawers.*) Do not pull out or install any drawer or feature if the rack stabilizer brackets are not attached to the rack. Do not pull out more than one drawer at a time. The rack might become unstable if you pull out more than one drawer at a time.



- (*For fixed drawers.*) This drawer is a fixed drawer and must not be moved for servicing unless specified by the manufacturer. Attempting to move the drawer partially or completely out of the rack might cause the rack to become unstable or cause the drawer to fall out of the rack.

CAUTION:

Removing components from the upper positions in the rack cabinet improves rack stability during relocation. Follow these general guidelines whenever you relocate a populated rack cabinet within a room or building.

- Reduce the weight of the rack cabinet by removing equipment starting at the top of the rack cabinet. When possible, restore the rack cabinet to the configuration of the rack cabinet as you received it. If this configuration is not known, you must observe the following precautions:
 - Remove all devices in the 32U position (compliance ID RACK-001 or 22U (compliance ID RR001) and above.
 - Ensure that the heaviest devices are installed in the bottom of the rack cabinet.
 - Ensure that there are little-to-no empty U-levels between devices installed in the rack cabinet below the 32U (compliance ID RACK-001 or 22U (compliance ID RR001) level, unless the received configuration specifically allowed it.
- If the rack cabinet you are relocating is part of a suite of rack cabinets, detach the rack cabinet from the suite.
- If the rack cabinet you are relocating was supplied with removable outriggers they must be reinstalled before the cabinet is relocated.
- Inspect the route that you plan to take to eliminate potential hazards.
- Verify that the route that you choose can support the weight of the loaded rack cabinet. Refer to the documentation that comes with your rack cabinet for the weight of a loaded rack cabinet.
- Verify that all door openings are at least 760 x 230 mm (30 x 80 in.).
- Ensure that all devices, shelves, drawers, doors, and cables are secure.
- Ensure that the four leveling pads are raised to their highest position.
- Ensure that there is no stabilizer bracket installed on the rack cabinet during movement.
- Do not use a ramp inclined at more than 10 degrees.
- When the rack cabinet is in the new location, complete the following steps:
 - Lower the four leveling pads.
 - Install stabilizer brackets on the rack cabinet.
 - If you removed any devices from the rack cabinet, repopulate the rack cabinet from the lowest position to the highest position.
- If a long-distance relocation is required, restore the rack cabinet to the configuration of the rack cabinet as you received it. Pack the rack cabinet in the original packaging material, or equivalent. Also lower the leveling pads to raise the casters off of the pallet and bolt the rack cabinet to the pallet.

(R002)

(L001)



DANGER: Hazardous voltage, current, or energy levels are present inside any component that has this label attached. Do not open any cover or barrier that contains this label. (L001)

(L002)



DANGER: Rack-mounted devices are not to be used as shelves or work spaces. (L002)

(L003)



or



or



or



or



DANGER: Multiple power cords. The product might be equipped with multiple AC power cords or multiple DC power cables. To remove all hazardous voltages, disconnect all power cords and power cables. (L003)

(L007)



CAUTION: A hot surface nearby. (L007)

(L008)



CAUTION: Hazardous moving parts nearby. (L008)

All lasers are certified in the U.S. to conform to the requirements of DHHS 21 CFR Subchapter J for class 1 laser products. Outside the U.S., they are certified to be in compliance with IEC 60825 as a class 1 laser product. Consult the label on each part for laser certification numbers and approval information.

CAUTION:

This product might contain one or more of the following devices: CD-ROM drive, DVD-ROM drive, DVD-RAM drive, or laser module, which are Class 1 laser products. Note the following information:

- **Do not remove the covers. Removing the covers of the laser product could result in exposure to hazardous laser radiation. There are no serviceable parts inside the device.**
- **Use of the controls or adjustments or performance of procedures other than those specified herein might result in hazardous radiation exposure.**

(C026)

CAUTION:

Data processing environments can contain equipment transmitting on system links with laser modules that operate at greater than Class 1 power levels. For this reason, never look into the end of an optical fiber cable or open receptacle. Although shining light into one end and looking into the other end of a disconnected optical fiber to verify the continuity of optic fibers many not injure the eye, this procedure is potentially dangerous. Therefore, verifying the continuity of optical fibers by shining light into one end and looking at the other end is not recommended. To verify continuity of a fiber optic cable, use an optical light source and power meter. (C027)

CAUTION:

This product contains a Class 1M laser. Do not view directly with optical instruments. (C028)

CAUTION:

Some laser products contain an embedded Class 3A or Class 3B laser diode. Note the following information: laser radiation when open. Do not stare into the beam, do not view directly with optical instruments, and avoid direct exposure to the beam. (C030)

CAUTION:

The battery contains lithium. To avoid possible explosion, do not burn or charge the battery.

Do Not:

- **Throw or immerse into water**
- **Heat to more than 100°C (212°F)**
- **Repair or disassemble**

Exchange only with the IBM-approved part. Recycle or discard the battery as instructed by local regulations. In the United States, IBM has a process for the collection of this battery. For information, call 1-800-426-4333. Have the IBM part number for the battery unit available when you call. (C003)

CAUTION:

Regarding IBM provided VENDOR LIFT TOOL:

- Operation of LIFT TOOL by authorized personnel only.
- LIFT TOOL intended for use to assist, lift, install, remove units (load) up into rack elevations. It is not to be used loaded transporting over major ramps nor as a replacement for such designated tools like pallet jacks, walkies, fork trucks and such related relocation practices. When this is not practicable, specially trained persons or services must be used (for instance, riggers or movers).
- Read and completely understand the contents of LIFT TOOL operator's manual before using. Failure to read, understand, obey safety rules, and follow instructions may result in property damage and/or personal injury. If there are questions, contact the vendor's service and support. Local paper manual must remain with machine in provided storage sleeve area. Latest revision manual available on vendor's web site.
- Test verify stabilizer brake function before each use. Do not over-force moving or rolling the LIFT TOOL with stabilizer brake engaged.
- Do not move LIFT TOOL while platform is raised, except for minor positioning.
- Do not exceed rated load capacity. See LOAD CAPACITY CHART regarding maximum loads at center versus edge of extended platform.
- Only raise load if properly centered on platform. Do not place more than 200 lb (91 kg) on edge of sliding platform shelf also considering the load's center of mass/gravity (CoG).
- Do not corner load the platform tilt riser accessory option. Secure platform riser tilt option to main shelf in all four (4x) locations with provided hardware only, prior to use. Load objects are designed to slide on/off smooth platforms without appreciable force, so take care not to push or lean. Keep riser tilt option flat at all times except for final minor adjustment when needed.
- Do not stand under overhanging load.
- Do not use on uneven surface, incline or decline (major ramps).
- Do not stack loads.
- Do not operate while under the influence of drugs or alcohol.
- Do not support ladder against LIFT TOOL.
- Tipping hazard. Do not push or lean against load with raised platform.
- Do not use as a personnel lifting platform or step. No riders.
- Do not stand on any part of lift. Not a step.
- Do not climb on mast.
- Do not operate a damaged or malfunctioning LIFT TOOL machine.
- Crush and pinch point hazard below platform. Only lower load in areas clear of personnel and obstructions. Keep hands and feet clear during operation.
- No Forks. Never lift or move bare LIFT TOOL MACHINE with pallet truck, jack or fork lift.
- Mast extends higher than platform. Be aware of ceiling height, cable trays, sprinklers, lights, and other overhead objects.
- Do not leave LIFT TOOL machine unattended with an elevated load.
- Watch and keep hands, fingers, and clothing clear when equipment is in motion.
- Turn Winch with hand power only. If winch handle cannot be cranked easily with one hand, it is probably over-loaded. Do not continue to turn winch past top or bottom of platform travel. Excessive unwinding will detach handle and damage cable. Always hold handle when lowering, unwinding. Always assure self that winch is holding load before releasing winch handle.
- A winch accident could cause serious injury. Not for moving humans. Make certain clicking sound is heard as the equipment is being raised. Be sure winch is locked in position before releasing handle. Read instruction page before operating this winch. Never allow winch to unwind freely. Freewheeling will cause uneven cable wrapping around winch drum, damage cable, and may cause serious injury. (C048)

Power and cabling information for NEBS (Network Equipment-Building System) GR-1089-CORE

The following comments apply to the IBM servers that have been designated as conforming to NEBS (Network Equipment-Building System) GR-1089-CORE:

The equipment is suitable for installation in the following:

- Network telecommunications facilities
- Locations where the NEC (National Electrical Code) applies

The intrabuilding ports of this equipment are suitable for connection to intrabuilding or unexposed wiring or cabling only. The intrabuilding ports of this equipment *must not* be metalically connected to the interfaces that connect to the OSP (outside plant) or its wiring. These interfaces are designed for use as intrabuilding interfaces only (Type 2 or Type 4 ports as described in GR-1089-CORE) and require isolation from the exposed OSP cabling. The addition of primary protectors is not sufficient protection to connect these interfaces metalically to OSP wiring.

Note: All Ethernet cables must be shielded and grounded at both ends.

The ac-powered system does not require the use of an external surge protection device (SPD).

The dc-powered system employs an isolated DC return (DC-I) design. The DC battery return terminal *shall not* be connected to the chassis or frame ground.

The dc-powered system is intended to be installed in a common bonding network (CBN) as described in GR-1089-CORE.

Installing the IBM Power System E850 (8408-E8E)

Learn how to install, cable, and set up your IBM Power System E850 (8408-E8E) server.

Prerequisite for installing the IBM Power System E850 (8408-E8E)

Use the information in this section to understand the prerequisites required for installing the IBM Power System E850 (8408-E8E) system.

Note: The IBM Power System E850 (8408-E8E) requires three people to lift the system and install it into a rack.

Ensure that you have the following items before starting your installation:

Note: If you are using the lift tool to install the server into the rack, use the instructions that were included with the lift tool.

Note: When you have finished using the installation tools, store them for future use.

- 4mm Allen hand tool (included)
- T25 hex tool (included)
- Phillips screwdriver
- Flat-head screwdriver
- Box cutter
- Electrostatic discharge (ESD) wrist strap
- Rack with 4 Electronic Industries Association (EIA) units (4U) of space

You also need one of the following consoles:

- Hardware management console (HMC) Version 8 Release 8.3.0, or later
- Graphics monitor with keyboard and mouse
- Teletype (TTY) monitor with keyboard

Completing inventory for your server

Use this information to complete inventory for your server.

To complete the inventory, complete the following steps:

1. Verify that you received all the boxes you ordered.
2. Unpack the server components as needed.
3. Complete a parts inventory before you install each server component by following these steps:
 - a. Locate the inventory list for your server.
 - b. Ensure that you received all the parts that you ordered.

Note: Your order information is included with your product. You can also obtain order information from your marketing representative or the IBM Business Partner.

If you have incorrect, missing, or damaged parts, consult any of the following resources:

- Your IBM reseller.
- IBM Rochester manufacturing automated information line at 1-800-300-8751 (United States only).

- The Directory of worldwide contacts website <http://www.ibm.com/planetwide>. Select your location to view the service and support contact information.
4. If you ordered DDR4 memory, two memory voltage regulator modules will be shipped with the ordered system. You must install them. To install the memory voltage regulator modules, complete the following steps:
 - a. Place the memory voltage regulator module into the connector of the system backplane, as shown in Figure 1.
 - b. Press down the memory voltage regulator module until it is firmly in place.

Note: When you install the memory voltage regulator module, ensure that the green tab (A) is on the side of the memory voltage regulator module that is closest to the front of the system. This will ensure that the memory voltage regulator module is oriented correctly and not installed 180 degrees front to back.

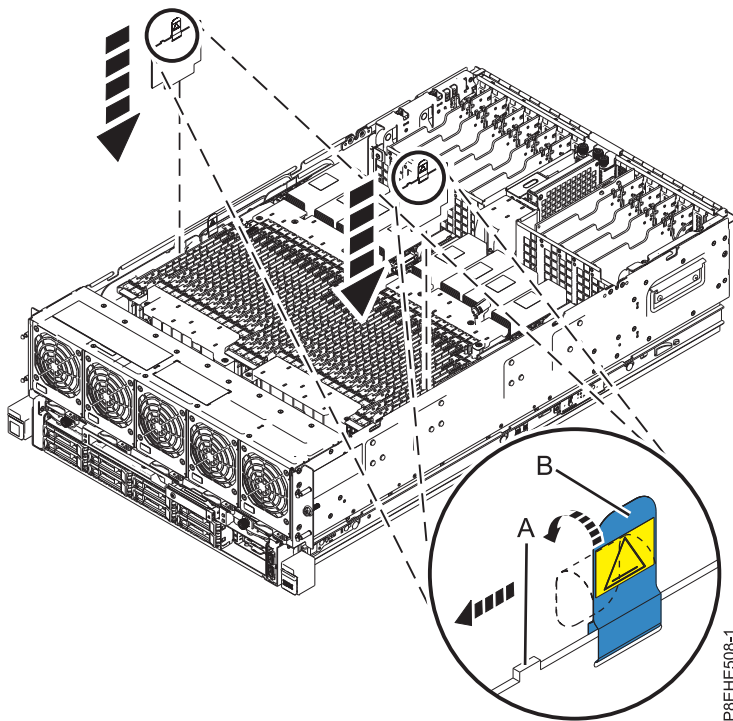

Figure 1. Installing the memory voltage regulator module

- c. Ensure that the blue tab (B) that extends above the memory voltage regulator module is moved toward the outside of the frame, and not toward the inside of the frame. If it is moved toward the inside of the frame, it can touch the adjoining card.

Attaching the lift handles to the chassis

Attach the four lift handles to the chassis so that three people can lift the chassis onto the mounting hardware.

To attach the lift handles to the chassis, complete the following steps:

1. Depress the latches on each side of the handle (A) using your thumb and index finger.

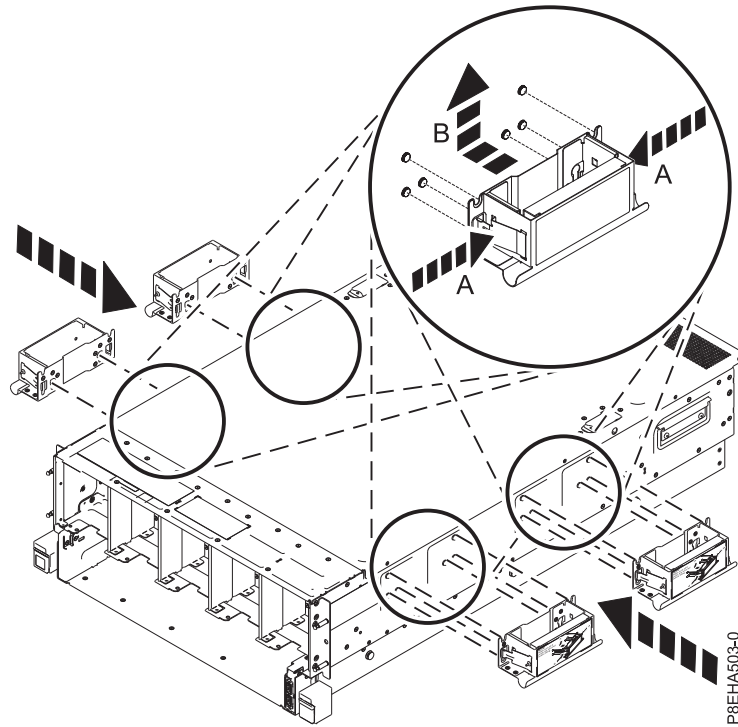

Figure 2. Installing the lift handles

2. Align the holes in the lift handles with the six pins on the chassis, and then lift the handle up (**B**), until the latches click into place.
3. Repeat these steps for all four lift handles.

Installing the server into a rack

You must remove components within the system chassis so that three people can lift it into the rack. Install the mounting hardware first, then remove components from the system chassis, and then lift the chassis into place.

Remove the following components from the front of the system chassis:

- System fans
- Front bezel
- Disk drive backplane

Remove the following components from the rear of the system:

- Power supplies

Attaching the mounting hardware to the rack

You might need to determine where to install the system in the rack, and install the mounting hardware. Use this procedure to perform this task.

Note: The system requires 4 EIA rack units (4U) of space.

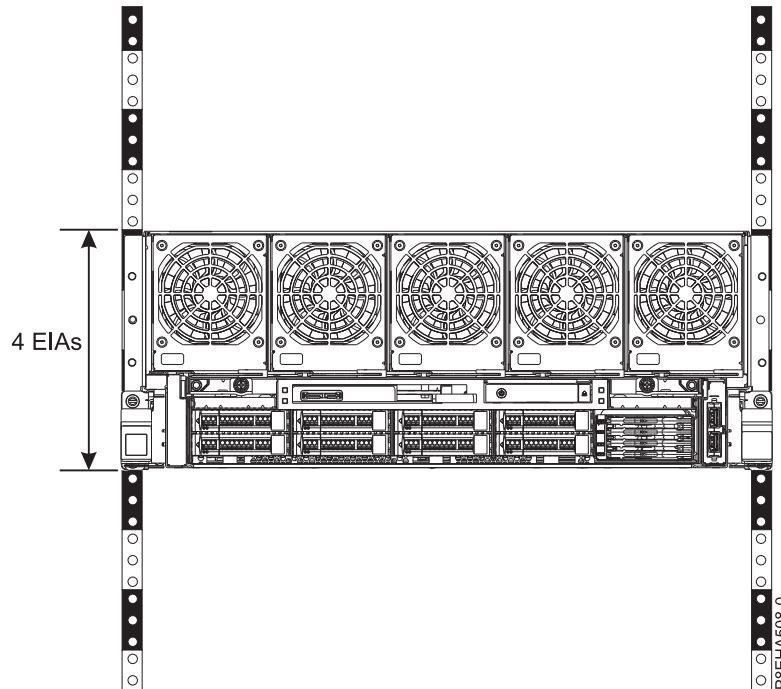

Figure 3. Rack with 4 EIA rack units (4U)

To install the rails into the rack, complete the following steps:

1. Use the rack-mount template to determine and mark the location.
2. Locate the left slide rail. The left mounting slide has an L identifier stamped into the inside front location.
3. At the front of the rack, position the left slide rail (**C**) between the left-side front and rear rack EIA mounting standards as shown in Figure 4 on page 5.
4. Insert the front slide flange locator studs into the front EIA mounting holes.

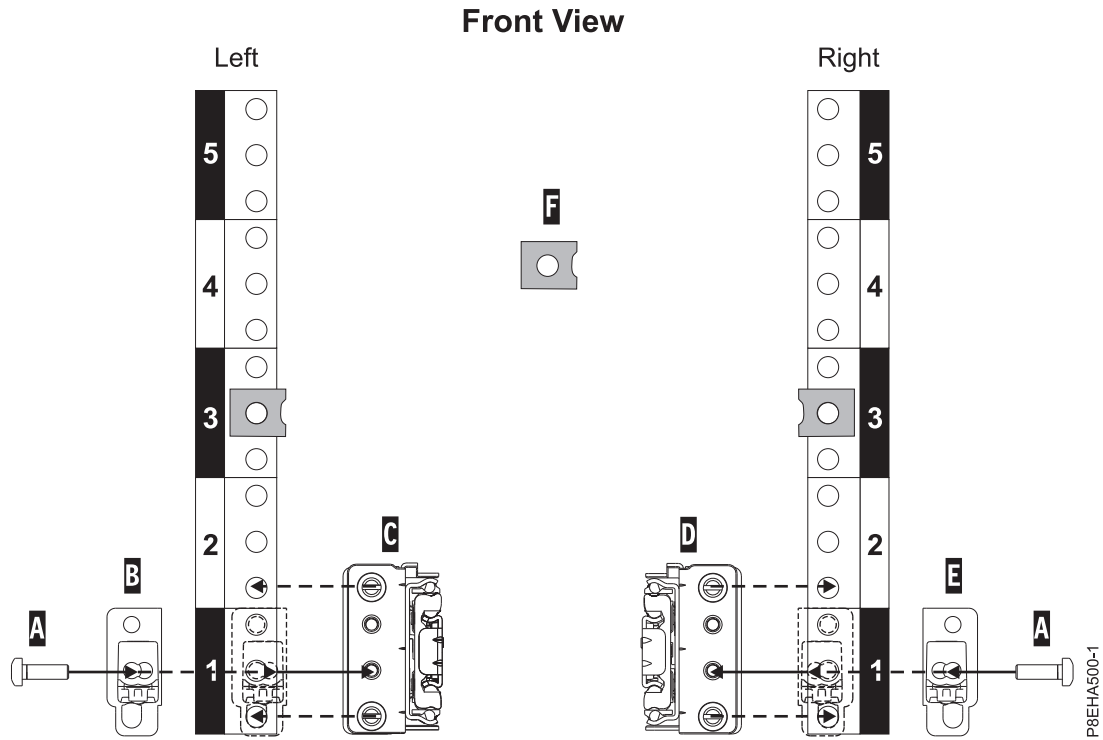

Figure 4. Attaching the slide rails at the front of the rack

5. Insert the rear slide flange locator studs on the slide rail into the rear EIA mounting holes.
6. Position the slam-latch bracket (B) to cover the front EIA space of the slide rail as shown in Figure 4.
7. Use the T25 hex tool to secure the slam-latch bracket to the front rail flange with one M5 X 16mm torx socket pan head screw (A) placed in the middle hole (1b) of the EIA rack unit as shown in Figure 4.
8. Repeat steps 2 on page 4 through 7 for the right slide rail (D) as shown in Figure 4. The right slide rail has an R identifier stamped into the inside front location.
9. Attach the two nut clips (F) to relative EIA locations 3b on both right and left front vertical EIA standards as shown in Figure 4.

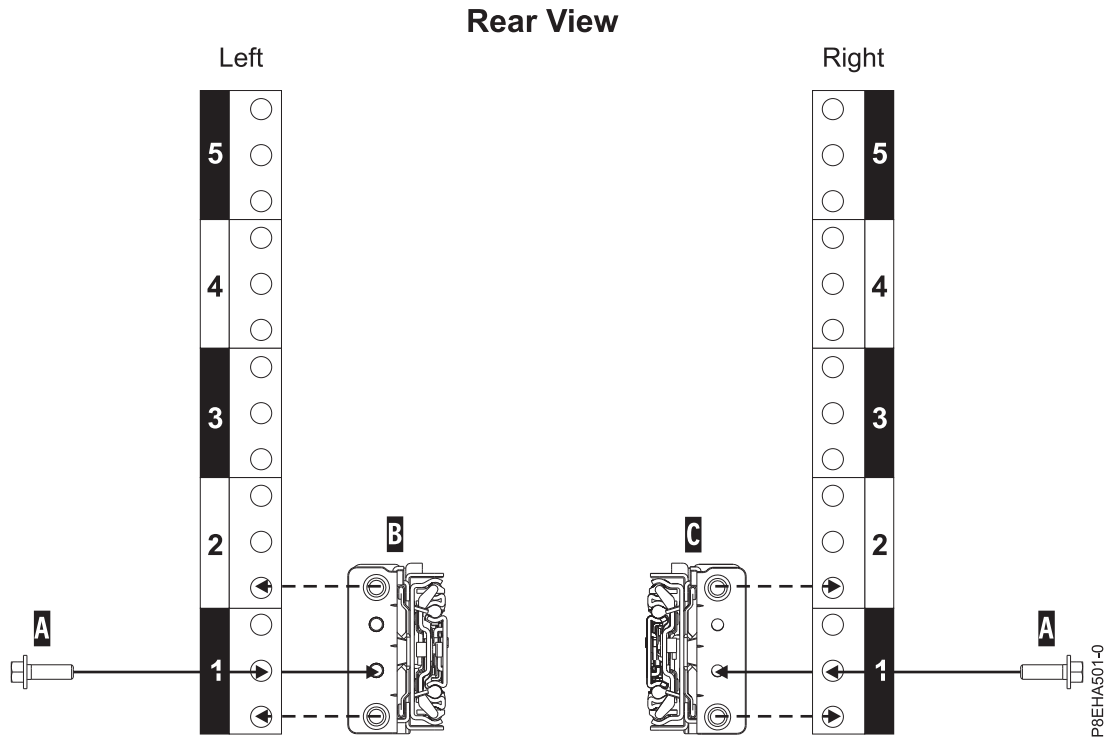

Figure 5. Attaching the slide rails at the rear of the rack

10. Move to the rear of the rack.
11. Working from the rear of the rack, verify that the locator studs have been installed in the correct holes of the rear EIA vertical mounting standards. If necessary, reposition the slide rail, and close the mechanism to hold it into place.
12. Secure the left slide rail (B) and right slide rail (C) with a M5x16mm screw (A) as shown in Figure 5. Insert and tighten each screw into the threaded slide flange hole, located in the middle hole of the lowest EIA rack unit.

Note: When you have finished using the installation tools, store them for future use.

Removing components from the system chassis

Before you install the system into the rack, you must remove components from the chassis, so that it is easier to lift.

Attention:

- Attach an electrostatic discharge (ESD) wrist strap to the front ESD jack, to the rear ESD jack, or to an unpainted metal surface of your hardware to prevent the electrostatic discharge from damaging your hardware.
- When you use an ESD wrist strap, follow all electrical safety procedures. An ESD wrist strap is used for static control. It does not increase or decrease your risk of receiving electric shock when using or working on electrical equipment.
- If you do not have an ESD wrist strap, just prior to removing the product from ESD packaging and installing or replacing hardware, touch an unpainted metal surface of the system for a minimum of 5 seconds.

Removing the power supplies

Learn how to remove the power supplies.

To remove the power supplies, complete the following steps:

1. Ensure that you have the wrist strap attached. If not, attach it now.
2. Push the terracotta locking-tab (A) in the direction shown in Figure 6.

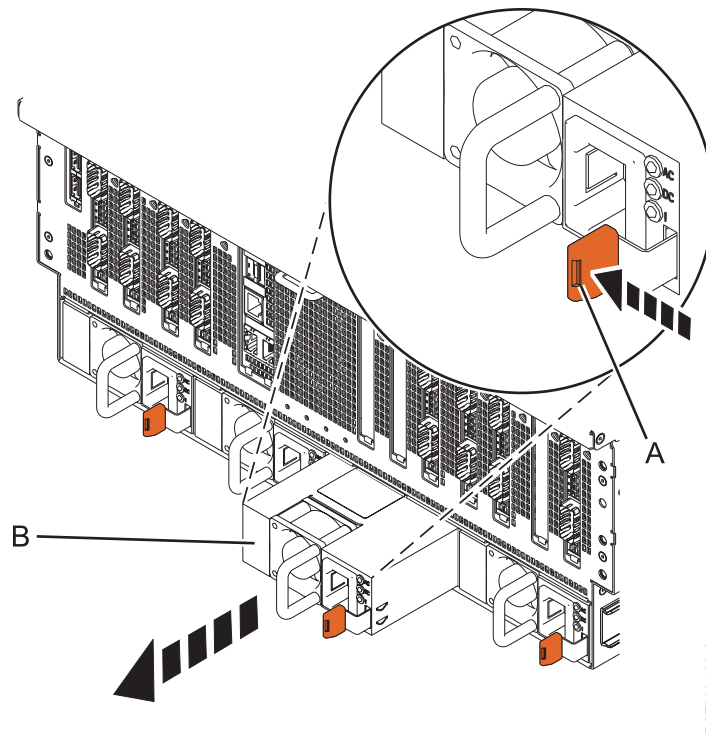

Figure 6. Removing a power supply from the rear of the system chassis

3. Pull the power supply (B) away from the system, as shown in Figure 6.

Removing the front cover

Learn how to remove the front cover.

To remove the front cover, complete the following steps:

1. Go to the front of the system chassis.
2. Place your fingers on the indentations (B) located on both sides of the cover.

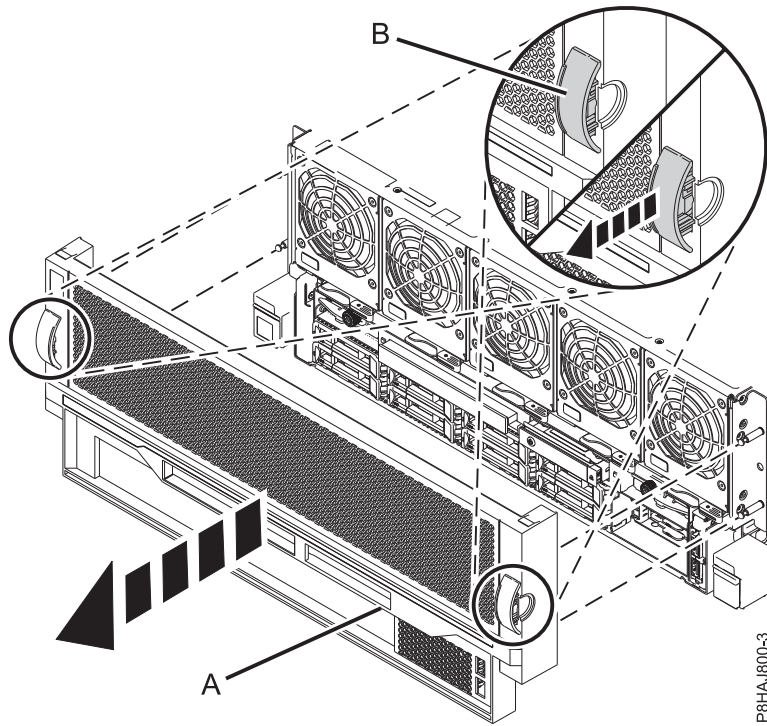

Figure 7. Removing the front cover

3. Pull the cover (A) away from the system.

Removing the system fans

Learn how to remove the system fans.

To remove the system fans, complete the following steps:

1. Rotate the fan handle (A) in the direction shown in Figure 8 on page 9 to unlock the fan from its slot.

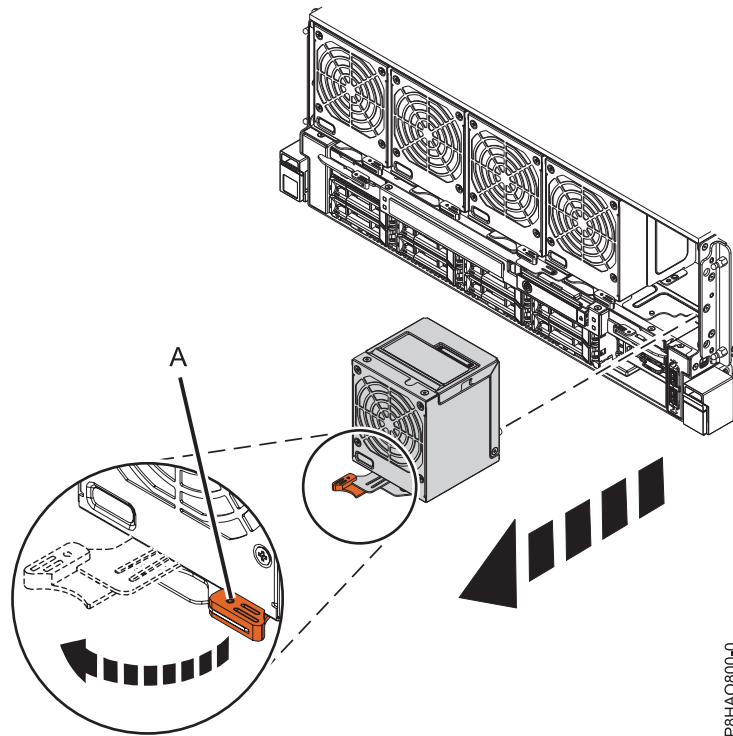

Figure 8. Removing the front fan

2. Hold on to the fan handle and by using your hand to support the bottom of the fan, pull out the fan from its slot.
3. Repeat these steps for each of the system fans.

Removing the disk drive backplane

Learn how to remove the disk drive backplane.

To remove the disk drive backplane, complete the following steps:

1. Use the included 4mm Allen hand tool to loosen the 2 captive shipping screws on the RAID assembly.

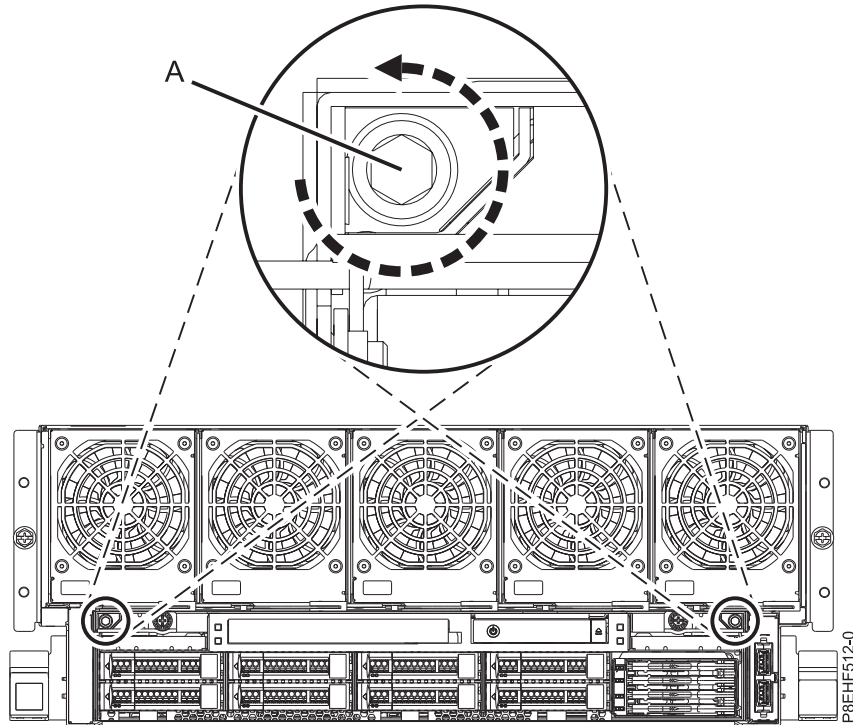

Figure 9. Loosening the captive shipping screws

Note: When you have finished using the installation tools, store them for future use.

2. Turn the thumbscrews on the RAID assembly to loosen them, as shown in Figure 10.

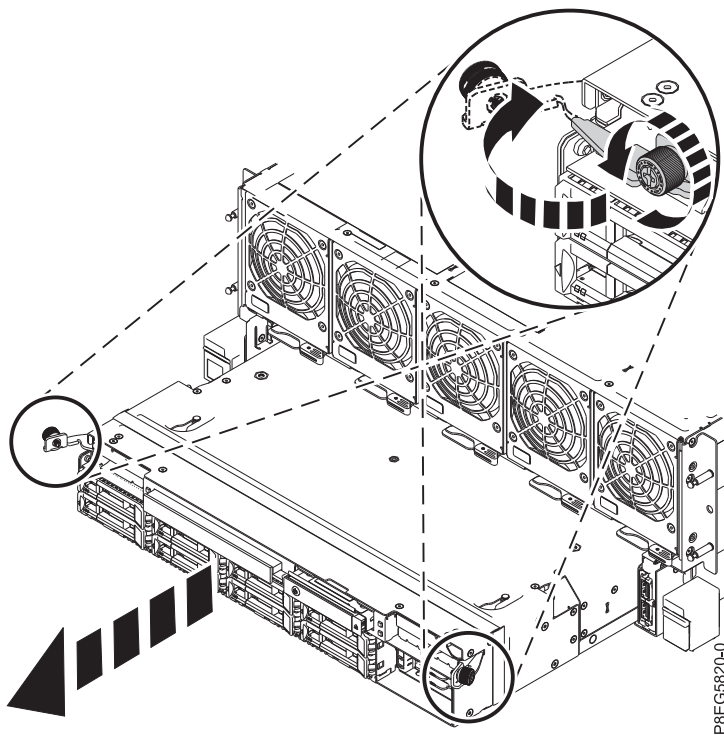

Figure 10. Removing the RAID assembly from the system

3. Pull out the latches and remove the disk drive backplane from the system.

Attaching the lift handles to the chassis

Attach the four lift handles to the chassis so that three people can lift the chassis onto the mounting hardware.

To attach the lift handles to the chassis, complete the following steps:

1. Depress the latches on each side of the handle (A) using your thumb and index finger.

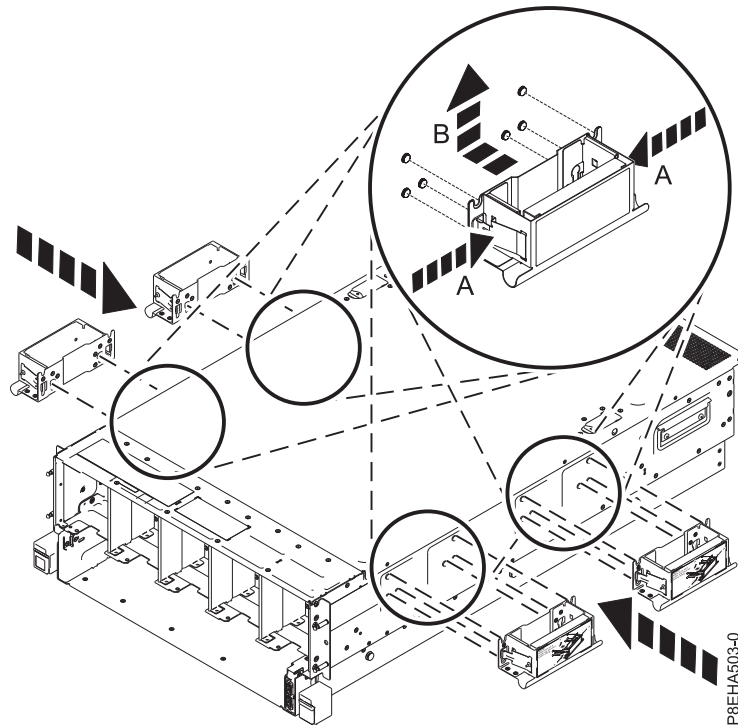

Figure 11. Installing the lift handles

2. Align the holes in the lift handles with the six pins on the chassis, and then lift the handle up (B), until the latches click into place.
3. Repeat these steps for all four lift handles.

Installing the system into the rack

Use the procedure in this section to install the system into the rack. The procedure includes information that is intended to promote safety and reliable operation.

CAUTION:

This system requires three people to install the system into the rack.

To install the system into the rack, complete the following steps:

1. Extend the mounting hardware (1) as shown in Figure 12 on page 12.

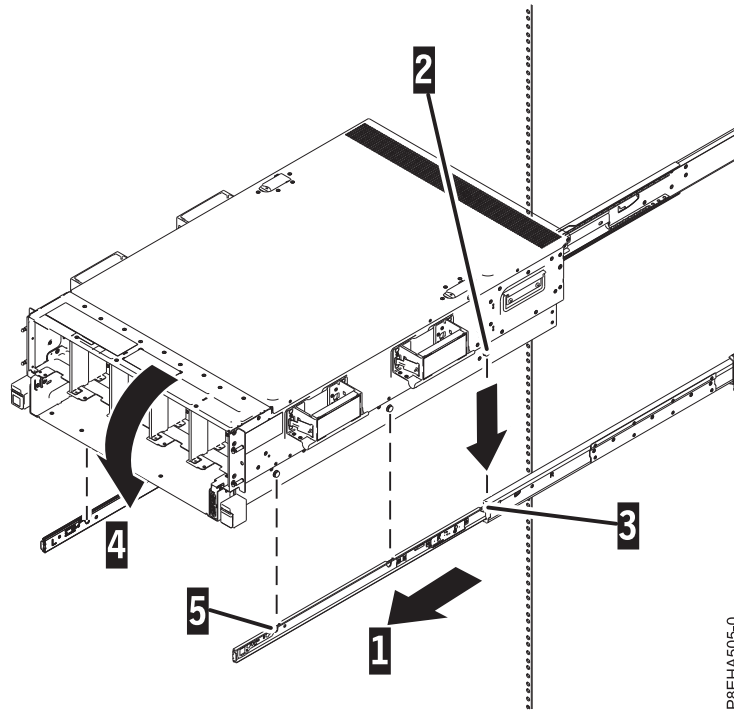

Figure 12. Installing the chassis onto the mounting hardware

2. Position one person in front of the system, one person on the left side of the system and one person on the right side of the system.
3. Using the lift handles, lift the chassis over the rails.
4. Tilt the front of system up so that the rear chassis pins (2) insert into the rear holes on the mounting hardware (3), as shown in as shown in Figure 12.
5. Tilt the front of the system down so that the chassis pins are inserted into the front (4 and 5) and middle holes in the mounting hardware, as shown in as shown in Figure 12.
6. Remove the lift handles on both sides of the chassis and store them for future use.
7. Release the latches in the middle of the rails and push the system all the way into the rack, as shown in Figure 13 on page 13.

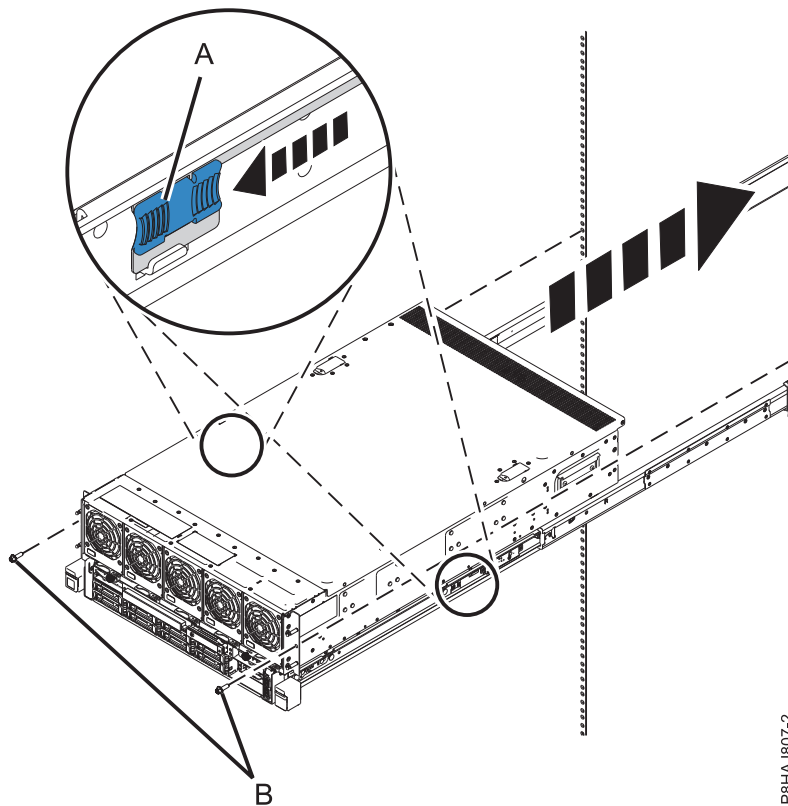

Figure 13. Releasing the latches in the middle of the rails and pushing the system all the way into the rack

8. Install the screws on either side of the system to secure the system to the rack.
9. Continue with “Replacing components into the system chassis.”

Replacing components into the system chassis

After you have installed the chassis onto the rails, you must replace the components that you removed.

Attention:

- Attach an electrostatic discharge (ESD) wrist strap to the front ESD jack, to the rear ESD jack, or to an unpainted metal surface of your hardware to prevent the electrostatic discharge from damaging your hardware.
- When you use an ESD wrist strap, follow all electrical safety procedures. An ESD wrist strap is used for static control. It does not increase or decrease your risk of receiving electric shock when using or working on electrical equipment.
- If you do not have an ESD wrist strap, just prior to removing the product from ESD packaging and installing or replacing hardware, touch an unpainted metal surface of the system for a minimum of 5 seconds.

Replacing the disk drive backplane

Learn how to replace the disk drive backplane

To replace the disk drive backplane, complete the following steps:

1. Move to the front of the rack.
2. Slide the disk drive backplane into the system.
3. Push the latches in and tighten the thumbscrews, as shown in Figure 14 on page 14.

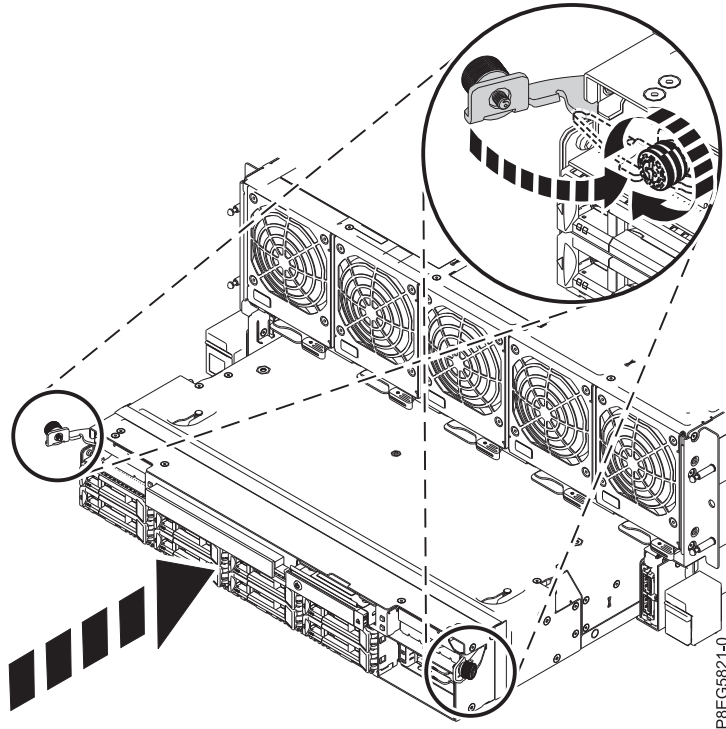

Figure 14. Replacing the disk drive backplane at the front of the system chassis

Note: Do not reinstall the shipping screws that you removed when you removed the disk drive backplane.

Replacing the system fans

Learn how to replace the system fans in the front of the system chassis.

To replace the system fans, complete the following steps:

1. Move to the front of the rack. Ensure that the fan handle (A) is rotated open in the direction shown in Figure 15 on page 15.
2. Using your hand to support the bottom of the fan, align the fan with the fan slot and slide it into the system.
3. Rotate the fan handle (A) in the direction shown and then press the fan handle until the latch locks in place. See Figure 15 on page 15.

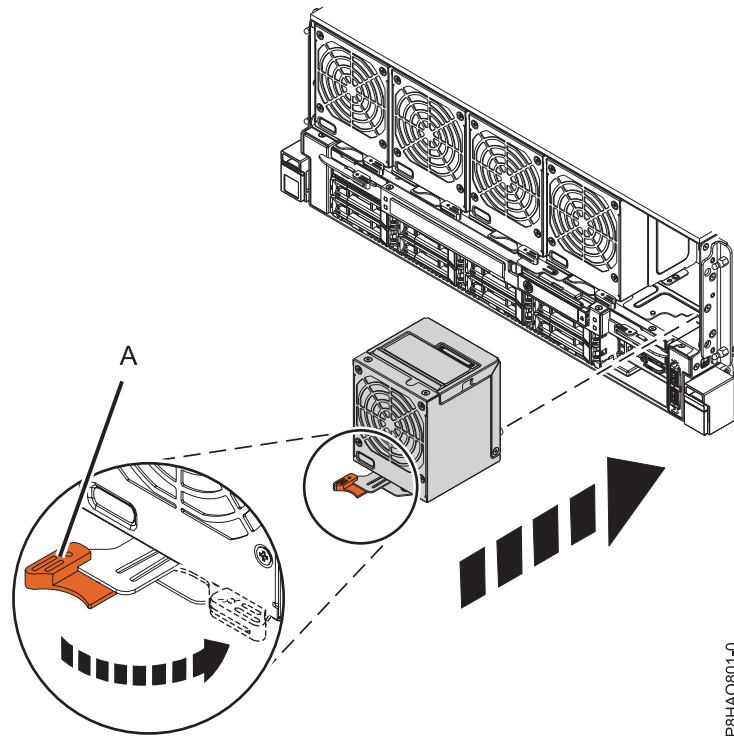

P8HAQ801-0

Figure 15. Replacing a front fan

Replacing the front cover

Learn how to replace the front cover.

To install the front cover, complete the following steps:

1. Move to the front of the rack.
2. Position the cover (**A**) on the front of the system unit so that the four pins on the system match the four holes on the rear of the cover.

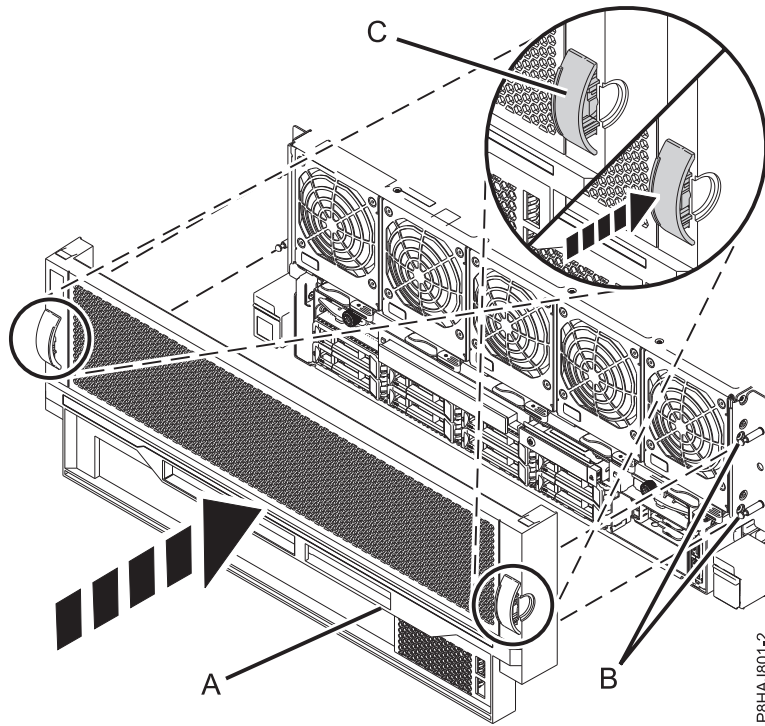

Figure 16. Installing the front cover

3. Press the tabs **(B)** to snap the cover into position.

Replacing the power supplies

Learn how to replace the power supplies.

To replace the power supplies, complete the following steps:

1. Ensure that you have the electrostatic discharge (ESD) wrist strap attached. If not, attach it now.
2. Move to the rear of the rack.
3. Align the power supply **(A)** with the bay and slide the power supply into the system until the terracotta latch **(B)** locks in place, as shown in Figure 17 on page 17.

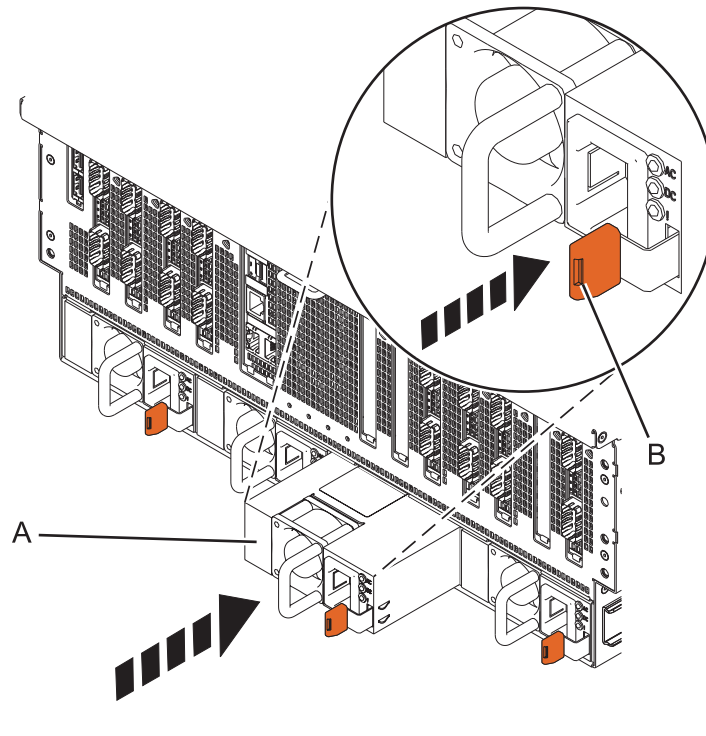

P8EHA507-0

Figure 17. Replacing a power supply in the system

Installing the cable-management arm

Use the cable management arm if you intend to provide extensive organization for the cables and cords connecting to the system.

To install the cable management arm, complete the following steps:

1. Attach the inner plate (**A**) to the system chassis by hand-tightening the two captive screws (**B**) through the threaded holes on the chassis, as shown in Figure 18 on page 18. Then use the T25 hex tool that was included with your system to tighten the bolts further.

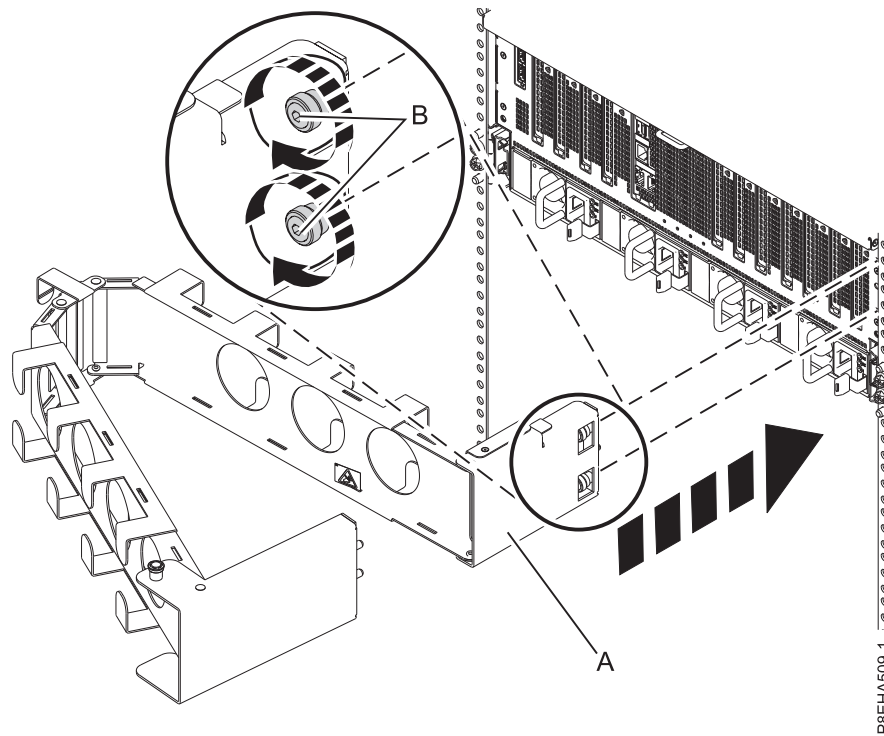

Figure 18. Attaching the inner plate to the system chassis

- Slide the system drawer forward, so that you can access the frame. Attach two nut clips (C) to the rack rail in the location where you will be attaching the outer plate to the rail, as shown in Figure 19.

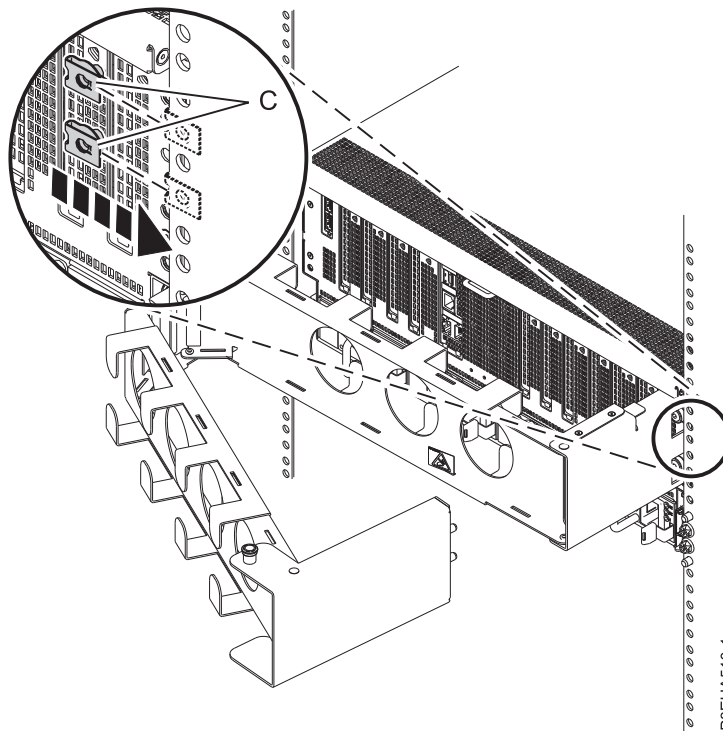

Figure 19. Attaching the nut clips to the rack rail

3. Attach the outer plate to the rails with two captive screws (E) as shown in Figure 20.

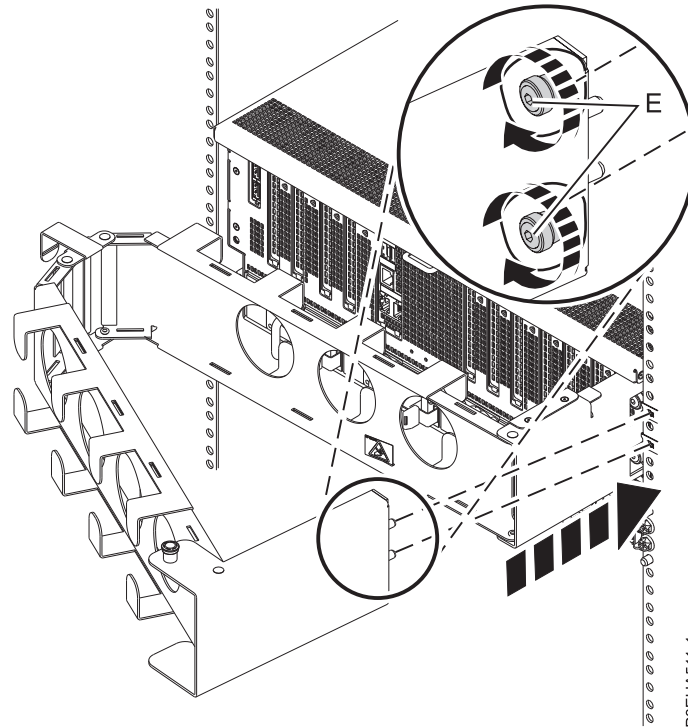

Figure 20. Attaching the outer plate to the rails

4. Next, you must route the system cables through the cable management arm. Continue with “Cabling the server and setting up a console.”

Cabling the server and setting up a console

Your console, monitor, or interface choices are guided by whether you create logical partitions, which operating system you install in your primary partition, and whether you install a Virtual I/O Server (VIOS) in one of your logical partitions.

Determining which console to use

There are different console types available to manage this server. Learn more about the consoles that are available.

Go to the instructions for the applicable console, interface, or terminal in the following table.

Table 1. Available console types

Console type	Operating system	Logical partitions	Cable required	Cabling setup instructions
ASCII terminal	AIX®, Linux, or VIOS	Yes for VIOS, no for AIX and Linux	Serial cable equipped with a null modem	“Cabling the server with an ASCII terminal” on page 20
Hardware Management Console (HMC)	AIX, Linux, or VIOS	Yes	Ethernet (or cross-over cable)	“Cabling the server to the HMC” on page 21
Integrated Virtualization Manager for VIOS	AIX, or Linux	Yes	Serial cable / Ethernet cable for LAN connection	“Cabling the server and accessing the IVM” on page 22

Table 1. Available console types (continued)

Console type	Operating system	Logical partitions	Cable required	Cabling setup instructions
Keyboard, video, and mouse (KVM)	Linux or VIOS	Yes	Monitor and USB cables equipped with KVM	"Cabling the server with keyboard, video, and mouse" on page 23

Cabling the server with an ASCII terminal

If you are not creating logical partitions, you can use an ASCII terminal to manage a server that is running the AIX, Linux, or VIOS operating systems. From the ASCII terminal, you can access the Advanced System Management Interface (ASMI) to complete more installation tasks.

The ASCII terminal is connected to the server through a serial link. The ASCII interface to the ASMI provides a subset of the web interface functions. The ASCII terminal for the ASMI interface is available only when the system is in the standby state. It is not available during the initial program load (IPL) or run time.

Note: If you are using a serial connection to the ASMI terminal, you must use a conversion cable. This cable (part number 46K5108) is used to convert the ASCII terminal 9-pin Dshell connector to an RJ45 serial port connector on the system. For information about the locations of the connectors on the system, see Part locations and location codes (http://www.ibm.com/support/knowledgecenter/POWER8/p8ecs/p8ecs_locations.htm).

To cable an ASCII terminal to the server, complete the following steps:

1. Using a serial cable that is equipped with a null modem, connect the ASCII terminal to the serial port on the rear of the server.
2. Complete the following steps:
 - a. Plug the power cord into the power supply.
 - b. Plug the system power cords and the power cords for any other attached devices into the power source.

Note: Confirm that the system is in standby mode. The green power status indicator on the front control panel is flashing, and the dc out indicator lights on the power supplies are flashing. If none of the indicators are flashing, check the power cord connections.

- c. If your system uses a power distribution unit (PDU), complete the following steps:
 - 1) Connect the system power cords from the server and I/O drawers to the PDU with an IEC 320 type receptacle.
 - 2) Attach the PDU input power cord and plug it into the power source.
 - 3) If your system uses two PDUs for redundancy, plug E1 and E2 to **PDU A** and E3 and E4 to **PDU B**
3. Wait for the green light on the control panel to start flashing.
4. Ensure that your ASCII terminal is set to the following general attributes.

These attributes are the default settings for the diagnostic programs. Be sure that your terminal is set according to these attributes before proceeding to the next step.

Table 2. Default settings for the diagnostic programs

General setup attributes	3151 /11/31/41 settings	3151 /51/61 settings	3161 /64 settings	Description
Line speed	19,200	19,200	19,200	Uses the 19,200 (bits per second) line speed to communicate with the system unit.

Table 2. Default settings for the diagnostic programs (continued)

General setup attributes	3151 /11/31/41 settings	3151 /51/61 settings	3161 /64 settings	Description
Word length (bits)	8	8	8	Selects 8 bits as a data word length (byte).
Parity	No	No	No	Does not add a parity bit and is used together with the word length attribute to form the 8-bit data word (byte).
Stop bit	1	1	1	Places a bit after a data word (byte).

5. Press a key on the ASCII terminal to allow the service processor to confirm the presence of the ASCII terminal.
6. When the login display appears for the ASMI, enter admin for the user ID and password.
7. Change the default password when you are prompted.
8. Press Enter until the server information appears. You have completed the setup for an ASCII terminal, and have started the ASMI.
9. Continue with “Completing the server setup without using an HMC” on page 26.

Cabling the server to the HMC

The Hardware Management Console (HMC) controls managed systems, including the management of logical partitions, the creation of a virtual environment, and the use of capacity on demand. Using service applications, the HMC can also communicate with managed systems to detect, consolidate, and forward information to IBM service for analysis.

If you have not installed and configured your HMC, do so now. For instructions, see Installation and configuration scenarios (<http://www.ibm.com/support/knowledgecenter/POWER8/p8hai/basichmcinstallationandconfigurationtaskflow.htm>).

To manage POWER8 processor-based servers, the HMC must be at version 8 release 8.3.0, or later. To view the HMC version and release, complete the following steps:

1. In the navigation area, click **Updates**.
2. In the work area, view and record the information that appears in the HMC Code Level section, including the HMC version, release, Service Pack, build level, and base versions.

If you need to update your HMC version and release, see Obtaining and applying machine code updates for the HMC with an Internet connection (<http://www.ibm.com/support/knowledgecenter/POWER8/p8hai/area3fixeshmc.htm>).

To cable the server to the HMC, complete the following steps:

1. If you want to directly attach your HMC to the managed system, connect **Ethernet Connector 1** on the HMC to the **HMC1 (T4)** port on the managed system.

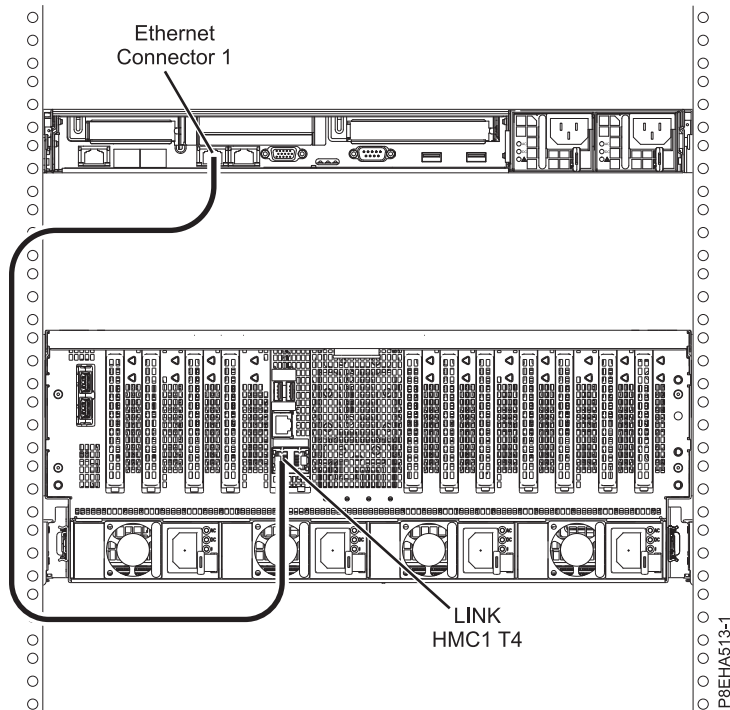

Figure 21. Attaching the HMC directly to the managed system

- To learn how to connect an HMC to a private network so that it can manage more than one managed system, see HMC network connections (<http://www.ibm.com/support/knowledgecenter/POWER8/p8hai/netconhmc.htm>).

Notes:

- You can also have multiple systems that are attached to a switch that is then connected to the HMC. For instructions, see HMC network connections (<http://www.ibm.com/support/knowledgecenter/POWER8/p8hai/netconhmc.htm>).
 - If you are using a switch, ensure that the speed in the switch is set to **Autodetection**. If the server is directly attached to the HMC, ensure the Ethernet adapter speed on the HMC is set to **Autodetection**. For information about how to set media speeds, see [Setting the media speed](http://www.ibm.com/support/knowledgecenter/POWER8/p8hai/lanmediaspeed.htm) (<http://www.ibm.com/support/knowledgecenter/POWER8/p8hai/lanmediaspeed.htm>).
- If you are connecting a second HMC to your managed server, connect it to the Ethernet port that is labeled **HMC2 (T5)** on the managed server.
 - Continue with “Cabling the server and connecting expansion units” on page 24.

Cabling the server and accessing the IVM

When you install the Virtual I/O Server (VIOS) in an environment where no Hardware Management Console (HMC) is present, the VIOS automatically creates a management partition whose interface is the Integrated Virtualization Manager (IVM).

To prepare for and install the VIOS and to enable the IVM, complete the following steps:

- Connect a serial cable from a PC or ASCII terminal to a system port on the server. For details, see “Cabling the server with an ASCII terminal” on page 20.
- Complete the following steps:
 - Verify that you have administrator or authorized service provider authority in ASMI.
 - Using the Web-based ASMI, change the following settings as appropriate for the type of partition on which you are installing the Integrated Virtualization Manager:

For an AIX or Linux partition, complete the following steps to change the partition boot mode:

- 1) In the navigation area, expand **Power/Restart Control**.
 - 2) Click **Power On/Off System**.
 - 3) Select **Boot to SMS menu** in the **AIX or Linux partition mode** by boot field.
 - 4) Click **Save settings and power on**.
- c. Open a terminal session on the PC, using an application such as HyperTerminal, and wait for the SMS menu to appear. Be sure that the line speed is set to 19,200 bits per second to communicate with the system unit.
- d. Using the Web-based ASMI, change the partition boot mode back so that the server loads the operating environment during startup:
- 1) Expand **Power/Restart Control**.
 - 2) Click **Power On/Off System**.
 - 3) Select **Continue to operating system** in the **AIX or Linux partition mode** boot field.
 - 4) Click **Save settings**.
3. Insert the *Virtual I/O Server* CD or DVD into the optical drive.
4. In SMS, select the CD or DVD as the boot device:
- a. Select **Select Boot Options**, and press Enter.
 - b. Select **Select Install/Boot Device**, and press Enter.
 - c. Select **CD/DVD**, and press Enter.
 - d. Select the media type that corresponds to the optical device, and press Enter.
 - e. Select the device number that corresponds to the optical device, and press Enter.
 - f. Select **Normal Boot**, and confirm that you want to exit SMS.
5. Install the Virtual I/O Server:
- a. Select the console, and press Enter.
 - b. Select a language for the BOS menus, and press Enter.
 - c. Select **Start Install Now with Default Settings**.
 - d. Select **Continue with Install**. The managed system restarts after the installation is complete, and the login prompt is displayed on the ASCII terminal.
6. After you install the IVM, finish the installation by accepting the license agreement, checking for updates, and configuring the TCP/IP connection.
7. Continue with “Cabling the server and connecting expansion units” on page 24.

Cabling the server with keyboard, video, and mouse

Before you start the system, you might need to connect the keyboard, video, and mouse to the system, if a graphics card is present.

To connect the keyboard, video, and mouse, complete the following steps:

1. Locate the graphics card and USB ports at the rear of the system. The USB ports are located next to slot 1 on the rear I/O cage.

Note: The USB ports on the FSP2 card are not used for keyboard and mouse connection.

2. Connect the monitor cable to the graphics card.
3. Connect a keyboard and mouse to the blue USB 3.0 ports.
4. Power on the console.
5. Continue with “Cabling the server and connecting expansion units” on page 24.

Cabling the server and connecting expansion units

Learn how to cable the server and to connect expansion units.

To cable the server and to connect expansion units, complete the following steps:

1. Complete the following steps:
 - a. Plug the power cords into the power supplies.
 - b. Route the power cords and other cables on the cable-management arm.
 - c. Attach all cables to the rear of the server.
 - d. Secure the cord and cables with cable ties or hook-and-loop fasteners.

Note: If your system uses two PDUs for redundancy, plug E1 and E2 to **PDU A** and E3 and E4 to **PDU B**. If your system uses four PDUs for redundancy, plug each power supply to a separate PDU.

 - e. Plug the system power cords and the power cords for any other attached devices into the power source.
 - f. If your system uses a power distribution unit (PDU), complete the following steps:
 - 1) Connect the system power cords from the server and I/O drawers to the PDU with the power cords that were included with the system.
 - 2) Attach the PDU input power cord and plug it into the power source.
 - 3) Confirm that the system is in standby mode. The green power status indicator on the front control panel is flashing, and the dc out indicator lights on the power supplies are flashing. If none of the indicators are flashing, check the power cord connections.
2. If you have an expansion unit that you need to install, install it now. For information about connecting enclosures and expansion units, see Enclosures and expansion units (http://www.ibm.com/support/knowledgecenter/POWER8/p8ham/p8ham_kickoff.htm).

Completing the server setup

Learn about the tasks you must complete to set up your managed system.

Select from the following options:

- “Completing the server setup by using an HMC”
- “Completing the server setup without using an HMC” on page 26

Completing the server setup by using an HMC

Perform these tasks to complete the server setup by using a Hardware Management Console (HMC). You can also begin to use virtualization to consolidate multiple workloads onto fewer systems to increase server use, and to reduce cost.

To manage POWER8[®] processor-based systems, the HMC must be at version 8 release 8.3.0, or later.

To complete the server setup by using an HMC, complete the following steps:

1. Change the managed system passwords by completing the following steps:

If you are using an HMC Classic or HMC Enhanced interface, complete the following steps:

 - a. In the navigation area, select the managed system.
 - b. In the Tasks area, click **Operations**.
 - c. Click **Change password**. The Update Password window opens.
 - d. Type the required information and click **OK**.

If you are using an HMC Enhanced+ interface, complete the following steps:

- a. In the navigation area, select the managed system and click the **Users and Security** icon, and then select **Users and Roles**.
- b. Click **Change Password**. The Update Password window opens.
- c. Type the required information and click **OK**.

For more information about setting passwords for the managed system by using the HMC Classic or HMC Enhanced interface, see [Setting passwords for the managed system \(http://www.ibm.com/support/knowledgecenter/POWER8/p8hai/setpasswordsforthemanagedsystem.htm\)](http://www.ibm.com/support/knowledgecenter/POWER8/p8hai/setpasswordsforthemanagedsystem.htm). For more information about setting passwords for the managed system by using the HMC Enhanced interface, see [Setting passwords for the managed system \(http://www.ibm.com/support/knowledgecenter/POWER8/p8hai/p8hai_setpassword_enh.htm\)](http://www.ibm.com/support/knowledgecenter/POWER8/p8hai/p8hai_setpassword_enh.htm).

2. Update the time of day on the managed system by using the Advanced System Management Interface (ASMI).

To access ASMI by using the HMC, choose one of the following navigation options depending on the interface type of the HMC:

If you are using an HMC Classic or HMC Enhanced interface, complete the following steps:

- a. In the navigation area, expand **Systems Management > Servers**.
- b. In the contents area, select the managed system.
- c. In the task area, expand **Operations**.
- d. Click **Launch Advanced System Management (ASM)**.
- e. Log on to the ASMI by using the administrator user ID and password.
- f. Select **System Config > Time of Day**.
- g. Adjust the time of day.
- h. Select **Save Settings**.

If you are using an HMC Enhanced+ interface, complete the following steps:

- a. In the navigation area, click the **Resources** icon, and then select **All Systems**.
- b. To view the actions for that server, select the server name of the required server.
- c. In the navigation area, click **System Actions > Operations > Launch Advanced System Management (ASM)**.
- d. Log on to the ASMI by using the administrator user ID and password.
- e. Select **System Config > Time of Day**.
- f. Adjust the time of day.
- g. Select **Save Settings**.

3. Check the firmware level on the managed system.

Note: The following operation is not supported by using the HMC Enhanced+ interface. If you are using the HMC Enhanced+ interface, log out of the HMC, and then log in to the HMC and select the HMC Classic or HMC Enhanced interface option.

- a. In the navigation area, click **Updates**.
- b. In the contents area, select the required managed system.
- c. Click **Change Licensed Internal Code for the current release**.
- d. Select **View system information** and then click **OK**.
- e. In the Specify LIC Repository window, select **None - Display current values** and then click **OK**.
- f. Record the level that appears in the **EC Number** field and the **Activated Level** field. For example, if the **EC Number** is 01EM310 and the **Activated Level** is 77, the firmware level is 01EM310_77.

4. Compare your installed firmware level with available firmware levels. If necessary, update your firmware levels.

- a. Compare your installed firmware level with available firmware levels. For more information, see the Fix Central website [Fix Central](http://www.ibm.com/fixcentral).

- b. If necessary, update your managed system firmware levels. In the navigation area, select **Updates**.
 - c. In the contents area, select your managed system.
 - d. Click **Change Licensed Internal Code for the current release**.
5. To power on a managed system, choose one of the following navigation options depending on the interface type of the HMC:

If you are using an HMC Classic or HMC Enhanced interface, complete the following steps:

- a. In the navigation area, click **Systems Management > Servers**.
- b. In the contents pane, select the required managed system.
- c. Click **Tasks > Operations > Power On**.

Follow any additional on-screen instructions.

If you are using an HMC Enhanced+ interface, complete the following steps:

- a. In the navigation area, click the **Resources** icon, and then select **All Systems**.
- b. In the content pane, select the required managed system name.
- c. In the navigation area, click **System Actions > Operations > Power On**.

Follow any additional on-screen instructions.

6. Configure and manage virtual resources. For instructions, see *Getting started with PowerVM®* (http://www.ibm.com/support/knowledgecenter/POWER8/p8eew/p8eew_kickoff.htm).
7. Create partitions using templates, if you logged in to the HMC by using the Enhanced or HMC Enhanced+ login option.
 - If you are creating new partitions, you can use the templates that are on your HMC. For more information, see *Accessing the template library* (http://www.ibm.com/support/knowledgecenter/POWER8/p8efc/p8efc_accessing_template_library.htm).
 - If you have existing partitions on another system, you can capture those configurations, save it to the template library and deploy the partition template. For more information, see *Partition templates* (http://www.ibm.com/support/knowledgecenter/POWER8/p8efc/p8efc_partition_template_concept.htm).
 - If you want to use an existing template from another source, you can import that and use it. For more information, see *Importing a partition template* (http://www.ibm.com/support/knowledgecenter/POWER8/p8efc/p8efc_import_partition_template.htm).

If you are using system plans or you did not log in to the HMC by using the HMC Enhanced or HMC Enhanced+ login option, you can create partitions or deploy system plans.

- For instructions about creating partitions, see *Partitioning with the HMC* (http://www.ibm.com/support/knowledgecenter/POWER8/p8hat/p8hat_lparwithhmc6.htm).
 - For instructions about deploying system plans, see *Deploying a system plan by using an HMC* (http://www.ibm.com/support/knowledgecenter/8286-41A/p8hc6/p8hc6_deploysysplan6.htm).
8. Install an operating system and update the operating system.
 - Install the AIX operating system. For instructions, see *Installing AIX* (http://www.ibm.com/support/knowledgecenter/POWER8/p8hdx/p8hdx_installaix.htm).
 - Install the Linux operating system. For instructions, see *Installing Linux* (http://www.ibm.com/support/knowledgecenter/POWER8/p8hdx/p8hdx_installlinux.htm).
 - Install the VIOS operating system. For instructions, see *Installing VIOS* (http://www.ibm.com/support/knowledgecenter/POWER8/p8hch/p8hch_installvios.htm).
 9. You have now completed the steps to install your server.

Completing the server setup without using an HMC

If you do not have an Hardware Management Console (HMC), use this procedure to complete the server setup.

To complete the server setup without using a management console, complete the following steps:

1. To check the firmware level on the managed system and to update the time of day, complete the following steps:
 - a. Access the Advanced System Management Interface (ASMI). For instructions, see [Accessing the ASMI without an HMC \(http://www.ibm.com/support/knowledgecenter/POWER8/p8hby/connect_asmi.htm\)](http://www.ibm.com/support/knowledgecenter/POWER8/p8hby/connect_asmi.htm).
 - b. On the ASMI Welcome pane, note the existing level of server firmware in the upper-right corner under the copyright statement.
 - c. Update the time of day. In the navigation area, expand **System Configuration**.
 - d. Click **Time of Day**. The content pane displays a form that shows the current date (month, day, and year) and time (hours, minutes, and seconds).
 - e. Change the date value, the time value, or both, and click **Save settings**.
2. To start a system, complete the following steps:
 - a. Open the front door of the managed system.
 - b. Press the power button on the control panel.

The power-on light begins to flash faster.

- a. The system cooling fans are activated after approximately 30 seconds and begin to accelerate to operating speed.
- b. Progress indicators appear on the control panel display while the system is being started.
- c. The power-on light on the control panel stops flashing and remains on, indicating that the system is powered on.

For instructions, see [Starting a system that is not managed by an HMC \(http://www.ibm.com/support/knowledgecenter/POWER8/p8haj/startsysnohmc.htm\)](http://www.ibm.com/support/knowledgecenter/POWER8/p8haj/startsysnohmc.htm).

3. Install an operating system and update the operating system.
 - Install the AIX operating system. For instructions, see [Installing AIX \(http://www.ibm.com/support/knowledgecenter/POWER8/p8hdx/p8hdx_installaix.htm\)](http://www.ibm.com/support/knowledgecenter/POWER8/p8hdx/p8hdx_installaix.htm).
 - Install the Linux operating system. For instructions, see [Installing Linux \(http://www.ibm.com/support/knowledgecenter/POWER8/p8hdx/p8hdx_installinux.htm\)](http://www.ibm.com/support/knowledgecenter/POWER8/p8hdx/p8hdx_installinux.htm).
 - Install the VIOS operating system. For instructions, see [Installing VIOS \(http://www.ibm.com/support/knowledgecenter/POWER8/p8hch/p8hch_installvios.htm\)](http://www.ibm.com/support/knowledgecenter/POWER8/p8hch/p8hch_installvios.htm).
4. Update the system firmware, if required.
 - For instructions to get firmware fixes through the AIX or Linux operating system, see [Getting server firmware fixes through AIX or Linux without a management console \(http://www.ibm.com/support/knowledgecenter/POWER8/p8ha5/fix_firm_no_hmc_aix.htm\)](http://www.ibm.com/support/knowledgecenter/POWER8/p8ha5/fix_firm_no_hmc_aix.htm).
 - If you are using VIOS, see [Updating the Virtual I/O Server's firmware and device microcode with an Internet connection \(http://www.ibm.com/support/knowledgecenter/POWER8/p8ha5/fix_virtual_firm_ivm.htm\)](http://www.ibm.com/support/knowledgecenter/POWER8/p8ha5/fix_virtual_firm_ivm.htm).
5. You have now completed the steps to install your server.

Setting up a preinstalled server

Use this information to learn about setting up a server that is preinstalled in a rack.

Preparing to set up your preinstalled server

Use the information to understand the prerequisites that are required for setting up the preinstalled server.

Attention:

- Attach an electrostatic discharge (ESD) wrist strap to the front ESD jack, to the rear ESD jack, or to an unpainted metal surface of your hardware to prevent the electrostatic discharge from damaging your hardware.
- When you use an ESD wrist strap, follow all electrical safety procedures. An ESD wrist strap is used for static control. It does not increase or decrease your risk of receiving electric shock when using or working on electrical equipment.
- If you do not have an ESD wrist strap, just prior to removing the product from ESD packaging and installing or replacing hardware, touch an unpainted metal surface of the system for a minimum of 5 seconds.

You might need to read the following documents before you install the server:

- Installing the IBM Power System E850 (8408-E8E) (http://www.ibm.com/support/knowledgecenter/POWER8/p8eha/p8eha_850_kickoff.htm).
- To plan your server installation, see Planning for the system (http://www.ibm.com/support/knowledgecenter/POWER8/p8had/p8had_8xx_kickoff.htm).
- If you are using a Hardware Management Console (HMC), see Obtaining and applying machine code updates for the HMC with an Internet connection (<http://www.ibm.com/support/knowledgecenter/POWER8/p8hai/area3fixeshmc.htm>).

Consider the following prerequisites before you install the server:

1. Ensure that you have the following items before you start your installation:
 - Phillips screwdriver
 - Flat-head screwdriver
 - Wire cutter
2. Ensure that you have one of the following consoles:
 - Hardware Management Console (HMC): Ensure that your HMC is at version 8 release 8.3.0, or later.
 - Graphic monitor with keyboard and mouse.
 - Teletype (tty) monitor with keyboard.

Completing inventory for your preinstalled server

Use this information to complete inventory for your server.

To complete the inventory, complete the following steps:

1. Verify that you received all the boxes you ordered.
2. Unpack the server components as needed.
3. Complete a parts inventory before you install each server component by following these steps:
 - a. Locate the inventory list for your server.
 - b. Ensure that you received all the parts that you ordered.

Note: Your order information is included with your product. You can also obtain order information from your marketing representative or the IBM Business Partner.

If you have incorrect, missing, or damaged parts, consult any of the following resources:

- Your IBM reseller.
- IBM Rochester manufacturing automated information line at 1-800-300-8751 (United States only).
- The Directory of worldwide contacts website <http://www.ibm.com/planetwide>. Select your location to view the service and support contact information.

Removing the shipping bracket and connecting power cords and power distribution unit (PDU) for your preinstalled server

You must remove the shipping bracket and cable ties before cabling the server.

To remove the shipping bracket and cable ties, complete the following steps:

1. Using wire cutters, clip and remove the orange plastic ties that secure the power supplies to the shipping bracket.
2. Remove the four screws that secure the shipping bracket to the chassis. Store the shipping bracket if you want to move your system at a later date.
3. Gently push the power supplies into the system chassis until they lock into place.
4. Cable the server.
 - a. Plug the power cords into the power supplies (A). See Figure 22.
 - b. Route the power cords and other cables on the cable-management arm.
 - c. Secure the cord and cables with cable ties or hook-and-loop fasteners (B), as shown in Figure 22.

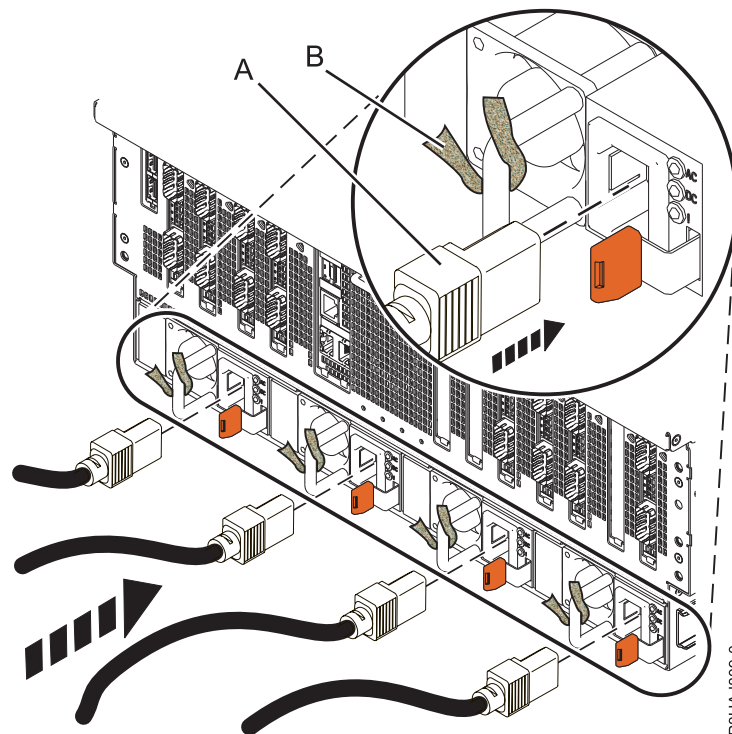
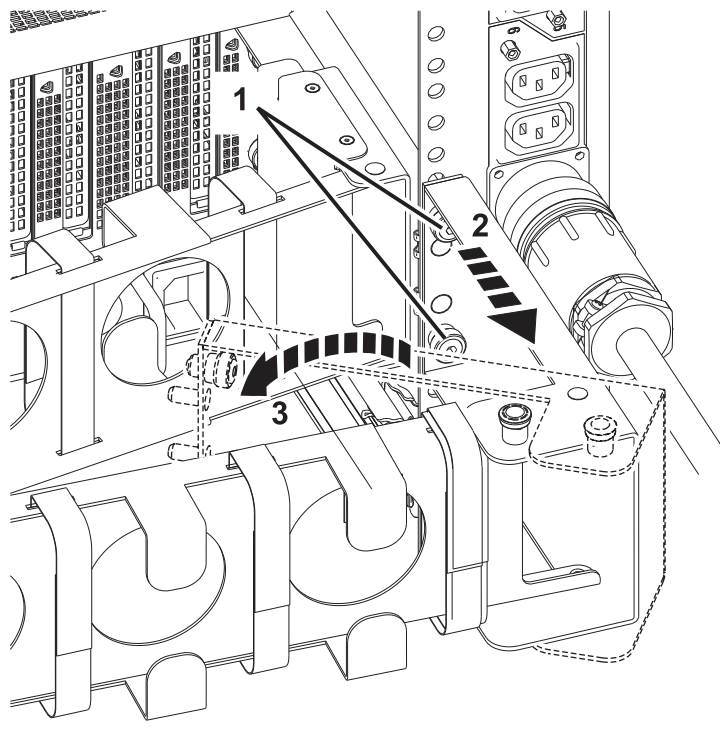

Figure 22. Plugging in the power cords and securing the cables with fasteners

- d. If you have a disk drive enclosure or expansion drawer that came preinstalled in this rack, use the documentation supplied with these options. For information about connecting enclosures and expansion units, see Enclosures and expansion units (http://www.ibm.com/support/knowledgecenter/POWER8/p8ham/p8ham_kickoff.htm).
 - e. Attach the PDU input power cord and plug it into the power source.
- Note:** If you are using redundant PDUs, verify that each of the power supplies are cabled and configured for redundancy.
5. If you ordered a fully-populated system, there are additional tasks you must perform so that you can access the line cord. To access the line cord on a fully-populated system, perform the following tasks:

- a. From the front of the system, pull the system out 3-4 inches.
- b. From the rear of the rack, loosen (but don't remove) the head screws (1). See Figure 23.
- c. Pull the cable management arm bracket toward you (2). See Figure 23.
- d. Pivot the cable management arm bracket to provide clearance (3). See Figure 23.



P8EHA514-0

Figure 23. Steps to provide line cord clearance in a fully-populated system

- e. Return the cable management arm bracket to its original position.
- f. Tighten the screws that you loosened in step b.

Cabling the server and setting up a console

Your console, monitor, or interface choices are guided by whether you create logical partitions, which operating system you install in your primary partition, and whether you install a Virtual I/O Server (VIOS) in one of your logical partitions.

Determining which console to use

There are different console types available to manage this server. Learn more about the consoles that are available.

Go to the instructions for the applicable console, interface, or terminal in the following table.

Table 3. Available console types

Console type	Operating system	Logical partitions	Cable required	Cabling setup instructions
ASCII terminal	AIX, Linux, or VIOS	Yes for VIOS, no for AIX and Linux	Serial cable equipped with a null modem	"Cabling the server with an ASCII terminal" on page 31
Hardware Management Console (HMC)	AIX, Linux, or VIOS	Yes	Ethernet (or cross-over cable)	"Cabling the server to the HMC" on page 32

Table 3. Available console types (continued)

Console type	Operating system	Logical partitions	Cable required	Cabling setup instructions
Integrated Virtualization Manager for VIOS	AIX, or Linux	Yes	Serial cable / Ethernet cable for LAN connection	"Cabling the server and accessing the IVM" on page 33
Keyboard, video, and mouse (KVM)	Linux or VIOS	Yes	Monitor and USB cables equipped with KVM	"Cabling the server with keyboard, video, and mouse" on page 34

Cabling the server with an ASCII terminal:

If you are not creating logical partitions, you can use an ASCII terminal to manage a server that is running the AIX, Linux, or VIOS operating systems. From the ASCII terminal, you can access the Advanced System Management Interface (ASMI) to complete more installation tasks.

The ASCII terminal is connected to the server through a serial link. The ASCII interface to the ASMI provides a subset of the web interface functions. The ASCII terminal for the ASMI interface is available only when the system is in the standby state. It is not available during the initial program load (IPL) or run time.

Note: If you are using a serial connection to the ASMI terminal, you must use a conversion cable. This cable (part number 46K5108) is used to convert the ASCII terminal 9-pin Dshell connector to an RJ45 serial port connector on the system. For information about the locations of the connectors on the system, see Part locations and location codes (http://www.ibm.com/support/knowledgecenter/POWER8/p8ecs/p8ecs_locations.htm).

To cable an ASCII terminal to the server, complete the following steps:

1. Using a serial cable that is equipped with a null modem, connect the ASCII terminal to the serial port on the rear of the server.
2. Complete the following steps:
 - a. Plug the power cord into the power supply.
 - b. Plug the system power cords and the power cords for any other attached devices into the power source.

Note: Confirm that the system is in standby mode. The green power status indicator on the front control panel is flashing, and the dc out indicator lights on the power supplies are flashing. If none of the indicators are flashing, check the power cord connections.

- c. If your system uses a power distribution unit (PDU), complete the following steps:
 - 1) Connect the system power cords from the server and I/O drawers to the PDU with an IEC 320 type receptacle.
 - 2) Attach the PDU input power cord and plug it into the power source.
 - 3) If your system uses two PDUs for redundancy, plug E1 and E2 to **PDU A** and E3 and E4 to **PDU B**
3. Press a key on the ASCII terminal to allow the service processor to confirm the presence of the ASCII terminal.
4. When the login display appears for the ASMI, enter admin for the user ID and password.
5. Change the default password when you are prompted.
6. Press Enter until the server information appears. You have completed the setup for an ASCII terminal, and have started the ASMI.

7. Continue with “Completing the server setup without using an HMC” on page 37.

Cabling the server to the HMC:

The Hardware Management Console (HMC) controls managed systems, including the management of logical partitions, the creation of a virtual environment, and the use of capacity on demand. Using service applications, the HMC can also communicate with managed systems to detect, consolidate, and forward information to IBM service for analysis.

If you have not installed and configured your HMC, do so now. For instructions, see Installation and configuration scenarios (<http://www.ibm.com/support/knowledgecenter/POWER8/p8hai/basichmcinstallationandconfigurationtaskflow.htm>).

To manage POWER8 processor-based servers, the HMC must be at version 8 release 8.3.0, or later. To view the HMC version and release, complete the following steps:

1. In the navigation area, click **Updates**.
2. In the work area, view and record the information that appears in the HMC Code Level section, including the HMC version, release, Service Pack, build level, and base versions.

If you need to update your HMC version and release, see Obtaining and applying machine code updates for the HMC with an Internet connection (<http://www.ibm.com/support/knowledgecenter/POWER8/p8hai/area3fixeshmc.htm>).

To cable the server to the HMC, complete the following steps:

1. If you want to directly attach your HMC to the managed system, connect **Ethernet Connector 1** on the HMC to the **HMC1 (T4)** port on the managed system.

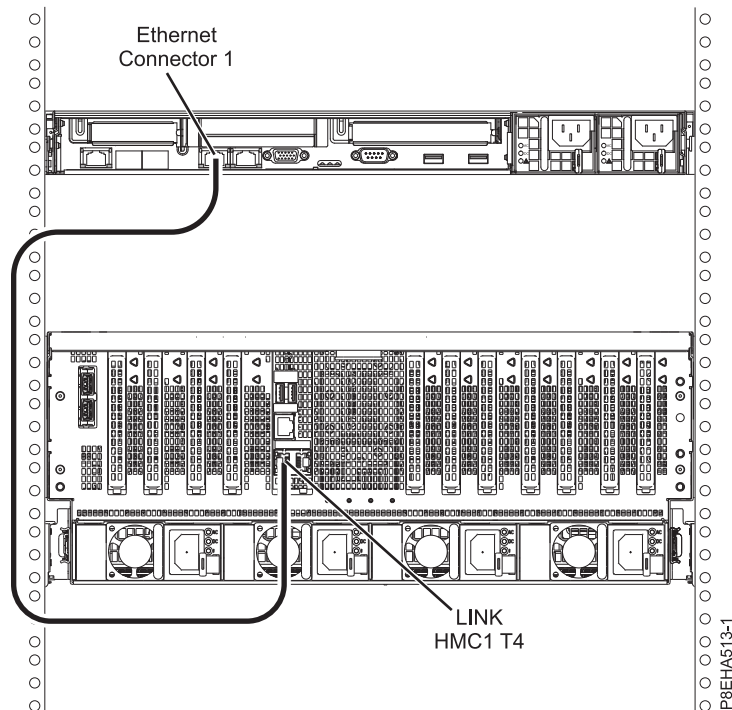

Figure 24. Attaching the HMC directly to the managed system

2. To learn how to connect an HMC to a private network so that it can manage more than one managed system, see HMC network connections (<http://www.ibm.com/support/knowledgecenter/POWER8/p8hai/netconhmc.htm>).

Notes:

- You can also have multiple systems that are attached to a switch that is then connected to the HMC. For instructions, see HMC network connections (<http://www.ibm.com/support/knowledgecenter/POWER8/p8hai/netconhmc.htm>).
 - If you are using a switch, ensure that the speed in the switch is set to **Autodetection**. If the server is directly attached to the HMC, ensure the Ethernet adapter speed on the HMC is set to **Autodetection**. For information about how to set media speeds, see [Setting the media speed](http://www.ibm.com/support/knowledgecenter/POWER8/p8hai/lanmediaspeed.htm) (<http://www.ibm.com/support/knowledgecenter/POWER8/p8hai/lanmediaspeed.htm>).
3. If you are connecting a second HMC to your managed server, connect it to the Ethernet port that is labeled **HMC2 (T5)** on the managed server.
 4. Continue with “Routing cables through the cable-management arm and connecting expansion units” on page 34.

Cabling the server and accessing the IVM:

When you install the Virtual I/O Server (VIOS) in an environment where no Hardware Management Console (HMC) is present, the VIOS automatically creates a management partition whose interface is the Integrated Virtualization Manager (IVM).

To prepare for and install the VIOS and to enable the IVM, complete the following steps:

1. Connect a serial cable from a PC or ASCII terminal to a system port on the server. For details, see “Cabling the server with an ASCII terminal” on page 31.
2. Complete the following steps:
 - a. Verify that you have administrator or authorized service provider authority in ASMI.
 - b. Using the Web-based ASMI, change the following settings as appropriate for the type of partition on which you are installing the Integrated Virtualization Manager:
For an AIX or Linux partition, complete the following steps to change the partition boot mode:
 - 1) In the navigation area, expand **Power/Restart Control**.
 - 2) Click **Power On/Off System**.
 - 3) Select **Boot to SMS menu** in the **AIX or Linux partition mode** by boot field.
 - 4) If you are installing the Integrated Virtualization Manager on an IBM System i[®] model, select **AIX or Linux** in the **Default partition environment** field.
 - 5) Click **Save settings and power on**.
 - c. Open a terminal session on the PC, using an application such as HyperTerminal, and wait for the SMS menu to appear. Be sure that the line speed is set to 19,200 bits per second to communicate with the system unit.
 - d. Using the Web-based ASMI, change the partition boot mode back so that the server loads the operating environment during startup:
 - 1) Expand **Power/Restart Control**.
 - 2) Click **Power On/Off System**.
 - 3) Select **Continue to operating system** in the **AIX or Linux partition mode** boot field.
 - 4) Click **Save settings**.
3. Insert the *Virtual I/O Server* CD or DVD into the optical drive.
4. In SMS, select the CD or DVD as the boot device:
 - a. Select **Select Boot Options**, and press Enter.
 - b. Select **Select Install/Boot Device**, and press Enter.

- c. Select **CD/DVD**, and press Enter.
 - d. Select the media type that corresponds to the optical device, and press Enter.
 - e. Select the device number that corresponds to the optical device, and press Enter.
 - f. Select **Normal Boot**, and confirm that you want to exit SMS.
5. Install the Virtual I/O Server:
 - a. Select the console, and press Enter.
 - b. Select a language for the BOS menus, and press Enter.
 - c. Select **Start Install Now with Default Settings**.
 - d. Select **Continue with Install**. The managed system restarts after the installation is complete, and the login prompt is displayed on the ASCII terminal.
 6. After you install the IVM, finish the installation by accepting the license agreement, checking for updates, and configuring the TCP/IP connection.
 7. Continue with “Routing cables through the cable-management arm and connecting expansion units.”

Cabling the server with keyboard, video, and mouse:

Before you start the system, you might need to connect the keyboard, video, and mouse to the system, if a graphics card is present.

To connect the keyboard, video, and mouse, complete the following steps:

1. Locate the graphics card and USB ports at the rear of the system. The USB ports are located next to slot 1 on the rear I/O cage.

Note: The USB ports on the FSP2 card are not used for keyboard and mouse connection.

2. Connect the monitor cable to the graphics card.
3. Connect a keyboard and mouse to the blue USB 3.0 ports.
4. Power on the console.
5. Continue with “Cabling the server and connecting expansion units” on page 24.

Routing cables through the cable-management arm and connecting expansion units

Use this procedure to route cables through the cable-management arm and to connect expansion units.

To route cables through the cable-management arm and to connect expansion units, complete the following steps:

1. Route the console cable through the cable management arm.
2. Connect expansion units that were shipped with the system. For more information, see the expansion unit installation documentation that was shipped with the system. Complete the tasks associated with connecting a preinstalled expansion unit or disk drive enclosure, then return to this document to complete your server setup.
3. Continue with “Completing the server setup.”

Completing the server setup

Learn about the tasks you must complete to set up your managed system.

Select from the following options:

- “Completing the server setup by using an HMC” on page 35
- “Completing the server setup without using an HMC” on page 37

Completing the server setup by using an HMC

Perform these tasks to complete the server setup by using a Hardware Management Console (HMC). You can also begin to use virtualization to consolidate multiple workloads onto fewer systems to increase server use, and to reduce cost.

To manage POWER8 processor-based systems, the HMC must be at version 8 release 8.4.0 or later.

To complete the server setup by using an HMC, complete the following steps:

Note: Once power has been applied to the system, wait for 10-15 minutes for the connection to the HMC to be established.

1. Change the managed system passwords by completing the following steps:

If you are using an HMC Classic or HMC Enhanced interface, complete the following steps:

- a. In the navigation area, select the managed system.
- b. In the Tasks area, click **Operations**.
- c. Click **Change password**. The Update Password window opens.
- d. Type the required information and click **OK**.

If you are using an HMC Enhanced+ interface, complete the following steps:

- a. In the navigation area, select the managed system and click the **Users and Security** icon, and then select **Users and Roles**.
- b. Click **Change Password**. The Update Password window opens.
- c. Type the required information and click **OK**.

For more information about setting passwords for the managed system by using the HMC Classic or HMC Enhanced interface, see [Setting passwords for the managed system \(http://www.ibm.com/support/knowledgecenter/POWER8/p8hai/setpasswordsforthemanagedsystem.htm\)](http://www.ibm.com/support/knowledgecenter/POWER8/p8hai/setpasswordsforthemanagedsystem.htm). For more information about setting passwords for the managed system by using the HMC Enhanced interface, see [Setting passwords for the managed system \(http://www.ibm.com/support/knowledgecenter/POWER8/p8hai/p8hai_setpassword_enh.htm\)](http://www.ibm.com/support/knowledgecenter/POWER8/p8hai/p8hai_setpassword_enh.htm).

2. Update the time of day on the managed system by using the Advanced System Management Interface (ASMI).

To access ASMI by using the HMC, choose one of the following navigation options depending on the interface type of the HMC:

If you are using an HMC Classic or HMC Enhanced interface, complete the following steps:

- a. In the navigation area, expand **Systems Management > Servers**.
- b. In the contents area, select the managed system.
- c. In the task area, expand **Operations**.
- d. Click **Launch Advanced System Management (ASM)**.
- e. Log on to the ASMI by using the administrator user ID and password.
- f. Select **System Config > Time of Day**.
- g. Adjust the time of day.
- h. Select **Save Settings**.

If you are using an HMC Enhanced+ interface, complete the following steps:

- a. In the navigation area, click the **Resources** icon, and then select **All Systems**.
- b. To view the actions for that server, select the server name of the required server.
- c. In the navigation area, click **System Actions > Operations > Launch Advanced System Management (ASM)**.
- d. Log on to the ASMI by using the administrator user ID and password.
- e. Select **System Config > Time of Day**.

- f. Adjust the time of day.
 - g. Select **Save Settings**.
3. Check the firmware level on the managed system.

Note: The following operation is not supported by using the HMC Enhanced+ interface. If you are using the HMC Enhanced+ interface, log out of the HMC, and then log in to the HMC and select the HMC Classic or HMC Enhanced interface option.

- a. In the navigation area, click **Updates**.
 - b. In the contents area, select the required managed system.
 - c. Click **Change Licensed Internal Code for the current release**.
 - d. Select **View system information** and then click **OK**.
 - e. In the Specify LIC Repository window, select **None - Display current values** and then click **OK**.
 - f. Record the level that appears in the **EC Number** field and the **Activated Level** field. For example, if the **EC Number** is 01EM310 and the **Activated Level** is 77, the firmware level is 01EM310_77.
4. Compare your installed firmware level with available firmware levels. If necessary, update your firmware levels.
 - a. Compare your installed firmware level with available firmware levels. For more information, see the Fix Central website Fix Central.
 - b. If necessary, update your managed system firmware levels. In the navigation area, select **Updates**.
 - c. In the contents area, select your managed system.
 - d. Click **Change Licensed Internal Code for the current release**.
 5. To power on a managed system, choose one of the following navigation options depending on the interface type of the HMC:

If you are using an HMC Classic or HMC Enhanced interface, complete the following steps:

- a. In the navigation area, click **Systems Management > Servers**.
- b. In the contents pane, select the required managed system.
- c. Click **Tasks > Operations > Power On**.

Follow any additional on-screen instructions.

If you are using an HMC Enhanced+ interface, complete the following steps:

- a. In the navigation area, click the **Resources** icon, and then select **All Systems**.
- b. In the content pane, select the required managed system name.
- c. In the navigation area, click **System Actions > Operations > Power On**.

Follow any additional on-screen instructions.

6. Configure and manage virtual resources. For instructions, see Getting started with PowerVM (http://www.ibm.com/support/knowledgecenter/POWER8/p8eew/p8eew_kickoff.htm).
7. Create partitions using templates, if you logged in to the HMC by using the Enhanced or HMC Enhanced+ login option.
 - If you are creating new partitions, you can use the templates that are on your HMC. For more information, see Accessing the template library (http://www.ibm.com/support/knowledgecenter/POWER8/p8efc/p8efc_accessing_template_library.htm).
 - If you have existing partitions on another system, you can capture those configurations, save it to the template library and deploy the partition template. For more information, see Partition templates (http://www.ibm.com/support/knowledgecenter/POWER8/p8efc/p8efc_partition_template_concept.htm).
 - If you want to use an existing template from another source, you can import that and use it. For more information, see Importing a partition template (http://www.ibm.com/support/knowledgecenter/POWER8/p8efc/p8efc_import_partition_template.htm).

If you are using system plans or you did not log in to the HMC by using the HMC Enhanced or HMC Enhanced+ login option, you can create partitions or deploy system plans.

- For instructions about creating partitions, see [Partitioning with the HMC \(http://www.ibm.com/support/knowledgecenter/POWER8/p8hat/p8hat_lparwithhmcp6.htm\)](http://www.ibm.com/support/knowledgecenter/POWER8/p8hat/p8hat_lparwithhmcp6.htm).
 - For instructions about deploying system plans, see [Deploying a system plan by using an HMC \(http://www.ibm.com/support/knowledgecenter/8286-41A/p8hc6/p8hc6_deploysysplanp6.htm\)](http://www.ibm.com/support/knowledgecenter/8286-41A/p8hc6/p8hc6_deploysysplanp6.htm).
8. Install an operating system and update the operating system.
 - Install the AIX operating system. For instructions, see [Installing AIX \(http://www.ibm.com/support/knowledgecenter/POWER8/p8hdx/p8hdx_installaix.htm\)](http://www.ibm.com/support/knowledgecenter/POWER8/p8hdx/p8hdx_installaix.htm).
 - Install the Linux operating system. For instructions, see [Installing Linux \(http://www.ibm.com/support/knowledgecenter/POWER8/p8hdx/p8hdx_installinux.htm\)](http://www.ibm.com/support/knowledgecenter/POWER8/p8hdx/p8hdx_installinux.htm).
 - Install the VIOS operating system. For instructions, see [Installing VIOS \(http://www.ibm.com/support/knowledgecenter/POWER8/p8hch/p8hch_installvios.htm\)](http://www.ibm.com/support/knowledgecenter/POWER8/p8hch/p8hch_installvios.htm).
 9. You have now completed the steps to install your server.

Completing the server setup without using an HMC

If you do not have an Hardware Management Console (HMC), use this procedure to complete the server setup.

To complete the server setup without using a management console, complete the following steps:

1. Attach the server to the rack using the shipping screws that were provided with your system.
2. To check the firmware level on the managed system and to update the time of day, complete the following steps:
 - a. Access the Advanced System Management Interface (ASMI). For instructions, see [Accessing the ASMI without an HMC \(http://www.ibm.com/support/knowledgecenter/POWER8/p8hby/connect_asmi.htm\)](http://www.ibm.com/support/knowledgecenter/POWER8/p8hby/connect_asmi.htm).
 - b. On the ASMI Welcome pane, note the existing level of server firmware in the upper-right corner under the copyright statement.
 - c. Update the time of day. In the navigation area, expand **System Configuration**.
 - d. Click **Time of Day**. The content pane displays a form that shows the current date (month, day, and year) and time (hours, minutes, and seconds).
 - e. Change the date value, the time value, or both, and click **Save settings**.
3. To start a system, complete the following steps:
 - a. Open the front door of the managed system.
 - b. Press the power button on the control panel.

The power-on light begins to flash faster.

- a. The system cooling fans are activated after approximately 30 seconds and begin to accelerate to operating speed.
- b. Progress indicators appear on the control panel display while the system is being started.
- c. The power-on light on the control panel stops flashing and remains on, indicating that the system is powered on.

For instructions, see [Starting a system that is not managed by an HMC \(http://www.ibm.com/support/knowledgecenter/POWER8/p8haj/startsysnohmc.htm\)](http://www.ibm.com/support/knowledgecenter/POWER8/p8haj/startsysnohmc.htm).

4. Install an operating system and update the operating system.
 - Install the AIX operating system. For instructions, see [Installing AIX \(http://www.ibm.com/support/knowledgecenter/POWER8/p8hdx/p8hdx_installaix.htm\)](http://www.ibm.com/support/knowledgecenter/POWER8/p8hdx/p8hdx_installaix.htm).
 - Install the Linux operating system. For instructions, see [Installing Linux \(http://www.ibm.com/support/knowledgecenter/POWER8/p8hdx/p8hdx_installinux.htm\)](http://www.ibm.com/support/knowledgecenter/POWER8/p8hdx/p8hdx_installinux.htm).

- Install the VIOS operating system. For instructions, see Installing VIOS (http://www.ibm.com/support/knowledgecenter/POWER8/p8hch/p8hch_installvios.htm).
5. Update the system firmware, if required.
 - For instructions to get firmware fixes through the AIX or Linux operating system, see Getting server firmware fixes through AIX or Linux without a management console (http://www.ibm.com/support/knowledgecenter/POWER8/p8ha5/fix_firm_no_hmc_aix.htm).
 - If you are using VIOS, see Updating the Virtual I/O Server's firmware and device microcode with an Internet connection (http://www.ibm.com/support/knowledgecenter/POWER8/p8ha5/fix_virtual_firm_ivm.htm).
 6. You have now completed the steps to install your server.

Notices

This information was developed for products and services offered in the US.

IBM may not offer the products, services, or features discussed in this document in other countries. Consult your local IBM representative for information on the products and services currently available in your area. Any reference to an IBM product, program, or service is not intended to state or imply that only that IBM product, program, or service may be used. Any functionally equivalent product, program, or service that does not infringe any IBM intellectual property right may be used instead. However, it is the user's responsibility to evaluate and verify the operation of any non-IBM product, program, or service.

IBM may have patents or pending patent applications covering subject matter described in this document. The furnishing of this document does not grant you any license to these patents. You can send license inquiries, in writing, to:

*IBM Director of Licensing
IBM Corporation
North Castle Drive, MD-NC119
Armonk, NY 10504-1785
US*

INTERNATIONAL BUSINESS MACHINES CORPORATION PROVIDES THIS PUBLICATION "AS IS" WITHOUT WARRANTY OF ANY KIND, EITHER EXPRESS OR IMPLIED, INCLUDING, BUT NOT LIMITED TO, THE IMPLIED WARRANTIES OF NON-INFRINGEMENT, MERCHANTABILITY OR FITNESS FOR A PARTICULAR PURPOSE. Some jurisdictions do not allow disclaimer of express or implied warranties in certain transactions, therefore, this statement may not apply to you.

This information could include technical inaccuracies or typographical errors. Changes are periodically made to the information herein; these changes will be incorporated in new editions of the publication. IBM may make improvements and/or changes in the product(s) and/or the program(s) described in this publication at any time without notice.

Any references in this information to non-IBM websites are provided for convenience only and do not in any manner serve as an endorsement of those websites. The materials at those websites are not part of the materials for this IBM product and use of those websites is at your own risk.

IBM may use or distribute any of the information you provide in any way it believes appropriate without incurring any obligation to you.

The performance data and client examples cited are presented for illustrative purposes only. Actual performance results may vary depending on specific configurations and operating conditions.

Information concerning non-IBM products was obtained from the suppliers of those products, their published announcements or other publicly available sources. IBM has not tested those products and cannot confirm the accuracy of performance, compatibility or any other claims related to non-IBM products. Questions on the capabilities of non-IBM products should be addressed to the suppliers of those products.

Statements regarding IBM's future direction or intent are subject to change or withdrawal without notice, and represent goals and objectives only.

All IBM prices shown are IBM's suggested retail prices, are current and are subject to change without notice. Dealer prices may vary.

This information is for planning purposes only. The information herein is subject to change before the products described become available.

This information contains examples of data and reports used in daily business operations. To illustrate them as completely as possible, the examples include the names of individuals, companies, brands, and products. All of these names are fictitious and any similarity to actual people or business enterprises is entirely coincidental.

If you are viewing this information in softcopy, the photographs and color illustrations may not appear.

The drawings and specifications contained herein shall not be reproduced in whole or in part without the written permission of IBM.

IBM has prepared this information for use with the specific machines indicated. IBM makes no representations that it is suitable for any other purpose.

IBM's computer systems contain mechanisms designed to reduce the possibility of undetected data corruption or loss. This risk, however, cannot be eliminated. Users who experience unplanned outages, system failures, power fluctuations or outages, or component failures must verify the accuracy of operations performed and data saved or transmitted by the system at or near the time of the outage or failure. In addition, users must establish procedures to ensure that there is independent data verification before relying on such data in sensitive or critical operations. Users should periodically check IBM's support websites for updated information and fixes applicable to the system and related software.

Homologation statement

This product may not be certified in your country for connection by any means whatsoever to interfaces of public telecommunications networks. Further certification may be required by law prior to making any such connection. Contact an IBM representative or reseller for any questions.

Accessibility features for IBM Power Systems servers

Accessibility features assist users who have a disability, such as restricted mobility or limited vision, to use information technology content successfully.

Overview

The IBM Power Systems servers include the following major accessibility features:

- Keyboard-only operation
- Operations that use a screen reader

The IBM Power Systems servers use the latest W3C Standard, WAI-ARIA 1.0 (www.w3.org/TR/wai-aria/), to ensure compliance with US Section 508 (www.access-board.gov/guidelines-and-standards/communications-and-it/about-the-section-508-standards/section-508-standards) and Web Content Accessibility Guidelines (WCAG) 2.0 (www.w3.org/TR/WCAG20/). To take advantage of accessibility features, use the latest release of your screen reader and the latest web browser that is supported by the IBM Power Systems servers.

The IBM Power Systems servers online product documentation in IBM Knowledge Center is enabled for accessibility. The accessibility features of IBM Knowledge Center are described in the Accessibility section of the IBM Knowledge Center help (www.ibm.com/support/knowledgcenter/doc/kc_help.html#accessibility).

Keyboard navigation

This product uses standard navigation keys.

Interface information

The IBM Power Systems servers user interfaces do not have content that flashes 2 - 55 times per second.

The IBM Power Systems servers web user interface relies on cascading style sheets to render content properly and to provide a usable experience. The application provides an equivalent way for low-vision users to use system display settings, including high-contrast mode. You can control font size by using the device or web browser settings.

The IBM Power Systems servers web user interface includes WAI-ARIA navigational landmarks that you can use to quickly navigate to functional areas in the application.

Vendor software

The IBM Power Systems servers include certain vendor software that is not covered under the IBM license agreement. IBM makes no representation about the accessibility features of these products. Contact the vendor for accessibility information about its products.

Related accessibility information

In addition to standard IBM help desk and support websites, IBM has a TTY telephone service for use by deaf or hard of hearing customers to access sales and support services:

TTY service
800-IBM-3383 (800-426-3383)
(within North America)

For more information about the commitment that IBM has to accessibility, see IBM Accessibility (www.ibm.com/able).

Privacy policy considerations

IBM Software products, including software as a service solutions, (“Software Offerings”) may use cookies or other technologies to collect product usage information, to help improve the end user experience, to tailor interactions with the end user, or for other purposes. In many cases no personally identifiable information is collected by the Software Offerings. Some of our Software Offerings can help enable you to collect personally identifiable information. If this Software Offering uses cookies to collect personally identifiable information, specific information about this offering’s use of cookies is set forth below.

This Software Offering does not use cookies or other technologies to collect personally identifiable information.

If the configurations deployed for this Software Offering provide you as the customer the ability to collect personally identifiable information from end users via cookies and other technologies, you should seek your own legal advice about any laws applicable to such data collection, including any requirements for notice and consent.

For more information about the use of various technologies, including cookies, for these purposes, see IBM’s Privacy Policy at <http://www.ibm.com/privacy> and IBM’s Online Privacy Statement at <http://www.ibm.com/privacy/details> the section entitled “Cookies, Web Beacons and Other Technologies” and the “IBM Software Products and Software-as-a-Service Privacy Statement” at <http://www.ibm.com/software/info/product-privacy>.

Trademarks

IBM, the IBM logo, and ibm.com are trademarks or registered trademarks of International Business Machines Corp., registered in many jurisdictions worldwide. Other product and service names might be trademarks of IBM or other companies. A current list of IBM trademarks is available on the web at Copyright and trademark information at www.ibm.com/legal/copytrade.shtml.

Linux is a registered trademark of Linus Torvalds in the United States, other countries, or both.

Electronic emission notices

When attaching a monitor to the equipment, you must use the designated monitor cable and any interference suppression devices supplied with the monitor.

Class A Notices

The following Class A statements apply to the IBM servers that contain the POWER8 processor and its features unless designated as electromagnetic compatibility (EMC) Class B in the feature information.

Federal Communications Commission (FCC) Statement

Note: This equipment has been tested and found to comply with the limits for a Class A digital device, pursuant to Part 15 of the FCC Rules. These limits are designed to provide reasonable protection against harmful interference when the equipment is operated in a commercial environment. This equipment generates, uses, and can radiate radio frequency energy and, if not installed and used in accordance with the instruction manual, may cause harmful interference to radio communications. Operation of this equipment in a residential area is likely to cause harmful interference, in which case the user will be required to correct the interference at his own expense.

Properly shielded and grounded cables and connectors must be used in order to meet FCC emission limits. IBM is not responsible for any radio or television interference caused by using other than recommended cables and connectors or by unauthorized changes or modifications to this equipment. Unauthorized changes or modifications could void the user's authority to operate the equipment.

This device complies with Part 15 of the FCC rules. Operation is subject to the following two conditions: (1) this device may not cause harmful interference, and (2) this device must accept any interference received, including interference that may cause undesired operation.

Industry Canada Compliance Statement

CAN ICES-3 (A)/NMB-3(A)

European Community Compliance Statement

This product is in conformity with the protection requirements of EU Council Directive 2014/30/EU on the approximation of the laws of the Member States relating to electromagnetic compatibility. IBM cannot accept responsibility for any failure to satisfy the protection requirements resulting from a non-recommended modification of the product, including the fitting of non-IBM option cards.

European Community contact:
IBM Deutschland GmbH
Technical Regulations, Abteilung M456
IBM-Allee 1, 71139 Ehningen, Germany
Tel: +49 800 225 5426
email: halloibm@de.ibm.com

Warning: This is a Class A product. In a domestic environment, this product may cause radio interference, in which case the user may be required to take adequate measures.

VCCI Statement - Japan

この装置は、クラスA 情報技術装置です。この装置を家庭環境で使用すると電波妨害を引き起こすことがあります。この場合には使用者が適切な対策を講ずるよう要求されることがあります。 VCCI-A

The following is a summary of the VCCI Japanese statement in the box above:

This is a Class A product based on the standard of the VCCI Council. If this equipment is used in a domestic environment, radio interference may occur, in which case, the user may be required to take corrective actions.

Japan Electronics and Information Technology Industries Association Statement

This statement explains the Japan JIS C 61000-3-2 product wattage compliance.

(一社) 電子情報技術産業協会 高調波電流抑制対策実施
要領に基づく定格入力電力値 : Knowledge Centerの各製品の
仕様ページ参照

This statement explains the Japan Electronics and Information Technology Industries Association (JEITA) statement for products less than or equal to 20 A per phase.

高調波電流規格 JIS C 61000-3-2 適合品

This statement explains the JEITA statement for products greater than 20 A, single phase.

高調波電流規格 JIS C 61000-3-2 準用品

本装置は、「高圧又は特別高圧で受電する需要家の高調波抑制対策ガイドライン」対象機器（高調波発生機器）です。

- 回路分類 : 6 (単相、PFC回路付)
- 換算係数 : 0

This statement explains the JEITA statement for products greater than 20 A per phase, three-phase.

高調波電流規格 JIS C 61000-3-2 準用品

本装置は、「高圧又は特別高圧で受電する需要家の高調波抑制対策ガイドライン」対象機器（高調波発生機器）です。

- 回路分類 : 5 (3相、PFC回路付)
- 換算係数 : 0

Electromagnetic Interference (EMI) Statement - People's Republic of China

声 明

此为 A 级产品,在生活环境
中,该产品可能会造成无线电干
扰。在这种情况下,可能需要用
户对其干扰采取切实可行的措
施。

Declaration: This is a Class A product. In a domestic environment this product may cause radio interference in which case the user may need to perform practical action.

Electromagnetic Interference (EMI) Statement - Taiwan

警告使用者：

這是甲類的資訊產品，在居住的環境中使用時，可能會造成射頻干擾，在這種情況下，使用者會被要求採取某些適當的對策。

The following is a summary of the EMI Taiwan statement above.

Warning: This is a Class A product. In a domestic environment this product may cause radio interference in which case the user will be required to take adequate measures.

IBM Taiwan Contact Information:

台灣IBM 產品服務聯絡方式：
台灣國際商業機器股份有限公司
台北市松仁路7號3樓
電話：0800-016-888

Electromagnetic Interference (EMI) Statement - Korea

이 기기는 업무용 환경에서 사용할 목적으로 적합성평가를 받은 기기로서 가정용 환경에서 사용하는 경우 전파간섭의 우려가 있습니다.

Germany Compliance Statement

Deutschsprachiger EU Hinweis: Hinweis für Geräte der Klasse A EU-Richtlinie zur Elektromagnetischen Verträglichkeit

Dieses Produkt entspricht den Schutzanforderungen der EU-Richtlinie 2014/30/EU zur Angleichung der Rechtsvorschriften über die elektromagnetische Verträglichkeit in den EU-Mitgliedsstaaten und hält die Grenzwerte der EN 55022 / EN 55032 Klasse A ein.

Um dieses sicherzustellen, sind die Geräte wie in den Handbüchern beschrieben zu installieren und zu betreiben. Des Weiteren dürfen auch nur von der IBM empfohlene Kabel angeschlossen werden. IBM übernimmt keine Verantwortung für die Einhaltung der Schutzanforderungen, wenn das Produkt ohne Zustimmung von IBM verändert bzw. wenn Erweiterungskomponenten von Fremdherstellern ohne Empfehlung von IBM gesteckt/eingebaut werden.

EN 55022 / EN 55032 Klasse A Geräte müssen mit folgendem Warnhinweis versehen werden:
"Warnung: Dieses ist eine Einrichtung der Klasse A. Diese Einrichtung kann im Wohnbereich Funk-Störungen verursachen; in diesem Fall kann vom Betreiber verlangt werden, angemessene Maßnahmen zu ergreifen und dafür aufzukommen."

Deutschland: Einhaltung des Gesetzes über die elektromagnetische Verträglichkeit von Geräten

Dieses Produkt entspricht dem "Gesetz über die elektromagnetische Verträglichkeit von Geräten (EMVG)". Dies ist die Umsetzung der EU-Richtlinie 2014/30/EU in der Bundesrepublik Deutschland.

Zulassungsbescheinigung laut dem Deutschen Gesetz über die elektromagnetische Verträglichkeit von Geräten (EMVG) (bzw. der EMC Richtlinie 2014/30/EU) für Geräte der Klasse A

Dieses Gerät ist berechtigt, in Übereinstimmung mit dem Deutschen EMVG das EG-Konformitätszeichen - CE - zu führen.

Verantwortlich für die Einhaltung der EMV Vorschriften ist der Hersteller:
International Business Machines Corp.
New Orchard Road
Armonk, New York 10504
Tel: 914-499-1900

Der verantwortliche Ansprechpartner des Herstellers in der EU ist:
IBM Deutschland GmbH
Technical Relations Europe, Abteilung M456
IBM-Allee 1, 71139 Ehningen, Germany
Tel: +49 (0) 800 225 5426
email: HalloIBM@de.ibm.com

Generelle Informationen:

Das Gerät erfüllt die Schutzanforderungen nach EN 55024 und EN 55022 / EN 55032 Klasse A.

Electromagnetic Interference (EMI) Statement - Russia

ВНИМАНИЕ! Настоящее изделие относится к классу А.
В жилых помещениях оно может создавать
радиопомехи, для снижения которых необходимы
дополнительные меры

Class B Notices

The following Class B statements apply to features designated as electromagnetic compatibility (EMC) Class B in the feature installation information.

Federal Communications Commission (FCC) Statement

This equipment has been tested and found to comply with the limits for a Class B digital device, pursuant to Part 15 of the FCC Rules. These limits are designed to provide reasonable protection against harmful interference in a residential installation.

This equipment generates, uses, and can radiate radio frequency energy and, if not installed and used in accordance with the instructions, may cause harmful interference to radio communications. However, there is no guarantee that interference will not occur in a particular installation.

If this equipment does cause harmful interference to radio or television reception, which can be determined by turning the equipment off and on, the user is encouraged to try to correct the interference by one or more of the following measures:

- Reorient or relocate the receiving antenna.
- Increase the separation between the equipment and receiver.
- Connect the equipment into an outlet on a circuit different from that to which the receiver is connected.
- Consult an IBM-authorized dealer or service representative for help.

Properly shielded and grounded cables and connectors must be used in order to meet FCC emission limits. Proper cables and connectors are available from IBM-authorized dealers. IBM is not responsible for any radio or television interference caused by unauthorized changes or modifications to this equipment. Unauthorized changes or modifications could void the user's authority to operate this equipment.

This device complies with Part 15 of the FCC rules. Operation is subject to the following two conditions: (1) this device may not cause harmful interference, and (2) this device must accept any interference received, including interference that may cause undesired operation.

Industry Canada Compliance Statement

CAN ICES-3 (B)/NMB-3(B)

European Community Compliance Statement

This product is in conformity with the protection requirements of EU Council Directive 2014/30/EU on the approximation of the laws of the Member States relating to electromagnetic compatibility. IBM cannot accept responsibility for any failure to satisfy the protection requirements resulting from a non-recommended modification of the product, including the fitting of non-IBM option cards.

European Community contact:
IBM Deutschland GmbH
Technical Regulations, Abteilung M456
IBM-Allee 1, 71139 Ehningen, Germany
Tel: +49 800 225 5426
email: halloibm@de.ibm.com

VCCI Statement - Japan

この装置は、クラスB情報技術装置です。この装置は、家庭環境で使用することを目的としていますが、この装置がラジオやテレビジョン受信機に近接して使用されると、受信障害を引き起こすことがあります。

取扱説明書に従って正しい取り扱いをして下さい。 VCCI-B

Japan Electronics and Information Technology Industries Association Statement

This statement explains the Japan JIS C 61000-3-2 product wattage compliance.

(一社) 電子情報技術産業協会 高調波電流抑制対策実施
要領に基づく定格入力電力値 : Knowledge Centerの各製品の
仕様ページ参照

This statement explains the Japan Electronics and Information Technology Industries Association (JEITA) statement for products less than or equal to 20 A per phase.

高調波電流規格 JIS C 61000-3-2 適合品

This statement explains the JEITA statement for products greater than 20 A, single phase.

高調波電流規格 JIS C 61000-3-2 準用品

本装置は、「高圧又は特別高圧で受電する需要家の高調波抑制対策ガイドライン」対象機器（高調波発生機器）です。

- 回路分類 : 6 (単相、PFC回路付)
- 換算係数 : 0

This statement explains the JEITA statement for products greater than 20 A per phase, three-phase.

高調波電流規格 JIS C 61000-3-2 準用品

本装置は、「高圧又は特別高圧で受電する需要家の高調波抑制対策ガイドライン」対象機器（高調波発生機器）です。

- 回路分類 : 5 (3相、PFC回路付)
- 換算係数 : 0

IBM Taiwan Contact Information

台灣IBM 產品服務聯絡方式：
台灣國際商業機器股份有限公司
台北市松仁路7號3樓
電話：0800-016-888

Germany Compliance Statement

Deutschsprachiger EU Hinweis: Hinweis für Geräte der Klasse B EU-Richtlinie zur Elektromagnetischen Verträglichkeit

Dieses Produkt entspricht den Schutzanforderungen der EU-Richtlinie 2014/30/EU zur Angleichung der Rechtsvorschriften über die elektromagnetische Verträglichkeit in den EU-Mitgliedsstaaten und hält die Grenzwerte der EN 55022/ EN 55032 Klasse B ein.

Um dieses sicherzustellen, sind die Geräte wie in den Handbüchern beschrieben zu installieren und zu betreiben. Des Weiteren dürfen auch nur von der IBM empfohlene Kabel angeschlossen werden. IBM übernimmt keine Verantwortung für die Einhaltung der Schutzanforderungen, wenn das Produkt ohne Zustimmung von IBM verändert bzw. wenn Erweiterungskomponenten von Fremdherstellern ohne Empfehlung von IBM gesteckt/eingebaut werden.

Deutschland: Einhaltung des Gesetzes über die elektromagnetische Verträglichkeit von Geräten

Dieses Produkt entspricht dem "Gesetz über die elektromagnetische Verträglichkeit von Geräten (EMVG)". Dies ist die Umsetzung der EU-Richtlinie 2014/30/EU in der Bundesrepublik Deutschland.

Zulassungsbescheinigung laut dem Deutschen Gesetz über die elektromagnetische Verträglichkeit von Geräten (EMVG) (bzw. der EMC Richtlinie 2014/30/EU) für Geräte der Klasse B

Dieses Gerät ist berechtigt, in Übereinstimmung mit dem Deutschen EMVG das EG-Konformitätszeichen - CE - zu führen.

Verantwortlich für die Einhaltung der EMV Vorschriften ist der Hersteller:
International Business Machines Corp.
New Orchard Road
Armonk, New York 10504

Tel: 914-499-1900

Der verantwortliche Ansprechpartner des Herstellers in der EU ist:

IBM Deutschland GmbH
Technical Relations Europe, Abteilung M456
IBM-Allee 1, 71139 Ehningen, Germany
Tel: +49 (0) 800 225 5426
email: HalloIBM@de.ibm.com

Generelle Informationen:

Das Gerät erfüllt die Schutzanforderungen nach EN 55024 und EN 55022/ EN 55032 Klasse B.

Terms and conditions

Permissions for the use of these publications are granted subject to the following terms and conditions.

Applicability: These terms and conditions are in addition to any terms of use for the IBM website.

Personal Use: You may reproduce these publications for your personal, noncommercial use provided that all proprietary notices are preserved. You may not distribute, display or make derivative works of these publications, or any portion thereof, without the express consent of IBM.

Commercial Use: You may reproduce, distribute and display these publications solely within your enterprise provided that all proprietary notices are preserved. You may not make derivative works of these publications, or reproduce, distribute or display these publications or any portion thereof outside your enterprise, without the express consent of IBM.

Rights: Except as expressly granted in this permission, no other permissions, licenses or rights are granted, either express or implied, to the publications or any information, data, software or other intellectual property contained therein.

IBM reserves the right to withdraw the permissions granted herein whenever, in its discretion, the use of the publications is detrimental to its interest or, as determined by IBM, the above instructions are not being properly followed.

You may not download, export or re-export this information except in full compliance with all applicable laws and regulations, including all United States export laws and regulations.

IBM MAKES NO GUARANTEE ABOUT THE CONTENT OF THESE PUBLICATIONS. THE PUBLICATIONS ARE PROVIDED "AS-IS" AND WITHOUT WARRANTY OF ANY KIND, EITHER EXPRESSED OR IMPLIED, INCLUDING BUT NOT LIMITED TO IMPLIED WARRANTIES OF MERCHANTABILITY, NON-INFRINGEMENT, AND FITNESS FOR A PARTICULAR PURPOSE.



Part Number: 01LK527

Printed in USA

GI11-9913-04



(1P) P/N: 01LK527

