

Power Systems

*Planar*

**IBM**



Power Systems

*Planar*

**IBM**



---

## Remove Planar

To remove a planar, complete the following steps:

1. When the node being serviced is above EIA location 29U, the ladders must be used while installing or removing the rear and front FRUs and cables.
2. Perform the following procedure on ONLY THE FRU(s) BEING SERVICED. The following images are generic and do not represent the literal location being serviced.
3. Modifying FRU locations which are not called out for service can have adverse effects on the system, INCLUDING SYSTEM OUTAGE AND LOSS OF DATA.
4. **CAUTION:** If the system slide rails are installed above EIA location 29U, two Support Services Representatives (SSRs) must perform the procedure together and the following equipment must be used as a safety precaution for servicing: ServerLIFT tool (P/N 74Y4399), two hard hats (P/N 5442867) and two service-qualified ladders (P/N 46G5947 and P/N 00E4866)

1. Remove front bezel
  - a. Remove the front bezel (A) from all system nodes which share the same system control unit that is being serviced.

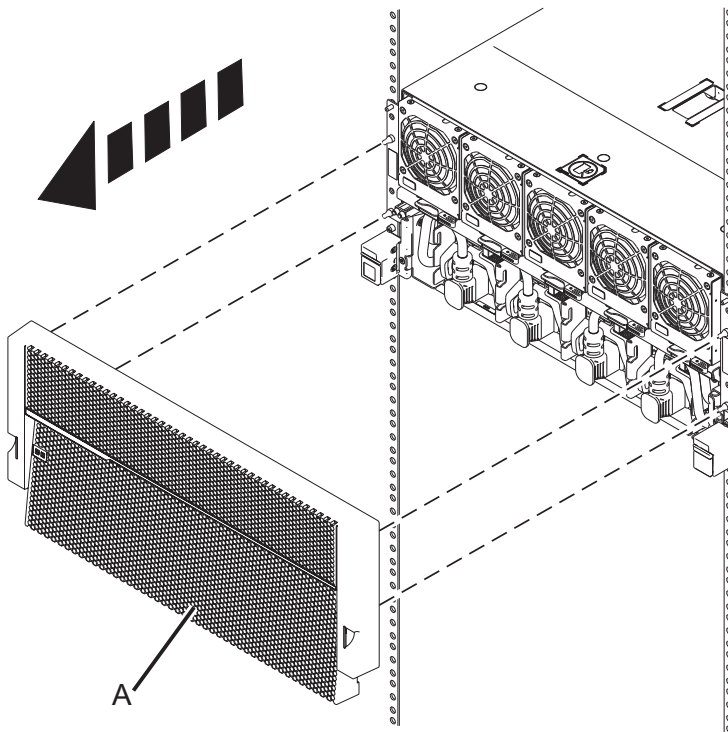

2. Remove power supply cables
  - a. Label the power supply cables so they can be plugged back into the same location.
  - b. Remove the power supply cables from all system nodes that are connected to the system control unit being serviced.
3. If there is a USB cable connected to the back of the system control unit, label and unplug it.

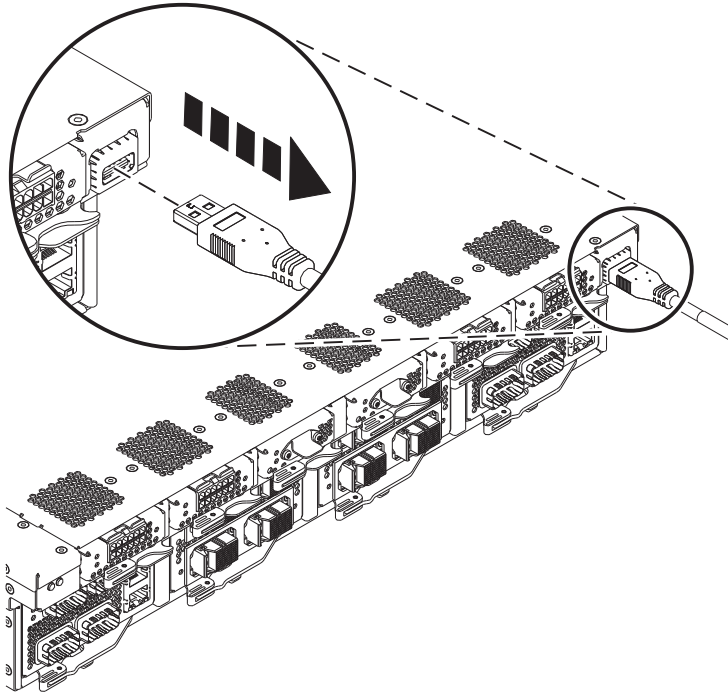

4. Remove the front bezel (A) from the system control unit.

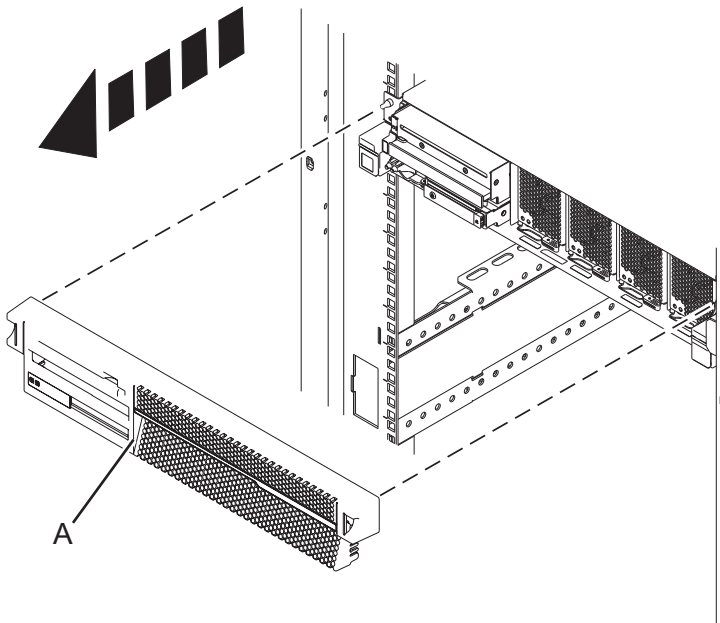

5. Remove all UPIC cables
- a. Note the Power Card configuration of your System Control Unit.
  - b. If your Power Card configuration contains two Power Cards, use the following image for reference:

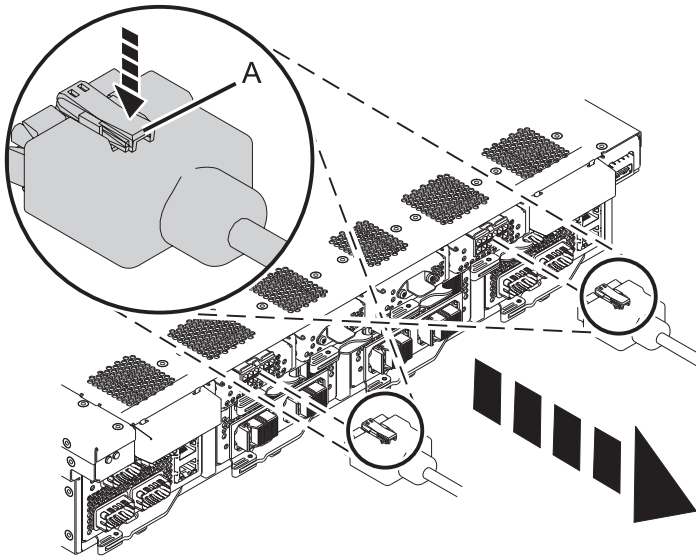

c. If your Power Card configuration contains four Power Cards, use the following image for reference:

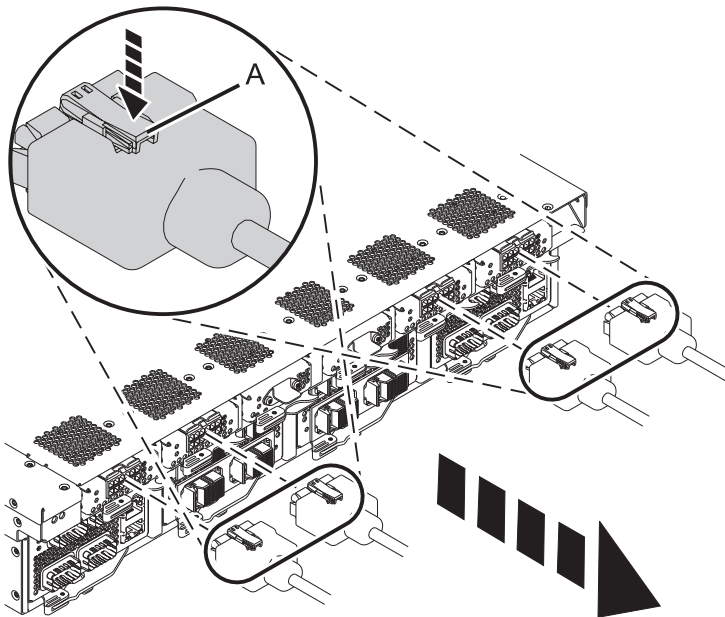

- d. If present, remove the plastic cable lock covers.
  - e. Push down on clips (A) and pull the UPIC cables out from the back of the power cards.
6. Remove all FSP and HMC cables
- a. Label the FSP and HMC cables so they can be plugged back into the same location.

- b. Disconnect the FSP cables (**A**) using the pull tab attached to each connector.
- c. Disconnect the HMC cables (**B**).

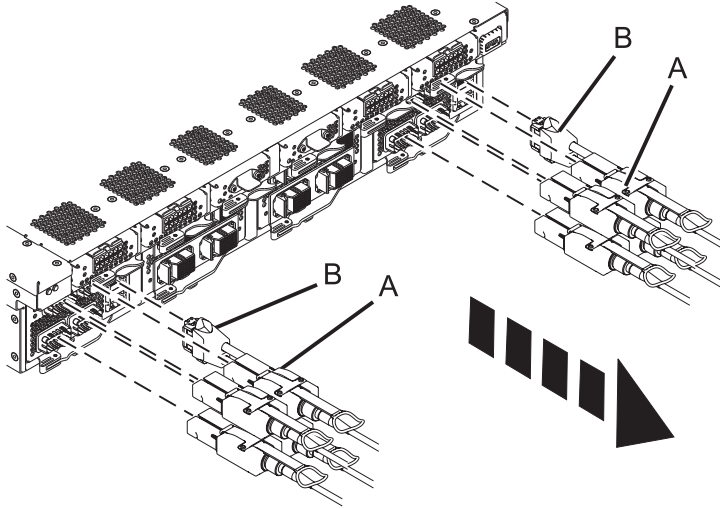

- 7. Remove all clock cables
  - a. Label the clock cables so they can be plugged back into the same location.
  - b. Detach the clock cables (**A**) by pushing the clock cable in slightly, then pull the locking tab to release the latch and pull cable out.

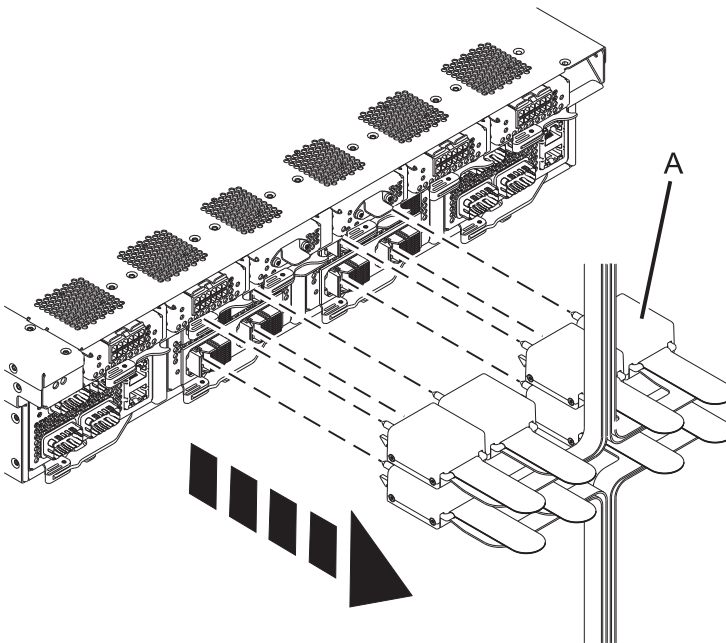



- c. Place the FRUs on an Electrostatic Discharge (ESD) surface.
8. Position lift tool

**Note:** If the system slide rails are installed at or below EIA location 29U, skip to the next step.

- a. With both SSRs wearing hard hats, position the ladders and the lift tool as shown in the graphic. The lift tool should be about one foot away from the rack with its platform slightly below the bottom of the system drawer to account for the slight downward flex when the drawer is extended out fully on its slides.

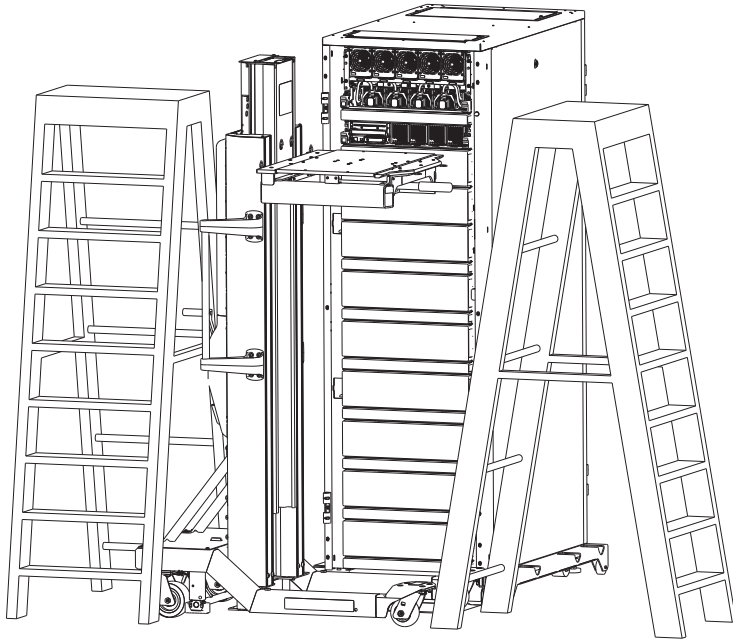

9. Move the system control unit into service position

**Note:** When placing the system into the service position, it is essential that all stability plates are firmly in position to prevent the rack from toppling.

**Note:** Ensure that only one system control unit is in the service position at a time.

- a. If present, remove the screws (A) that secure the system control unit to the rack.

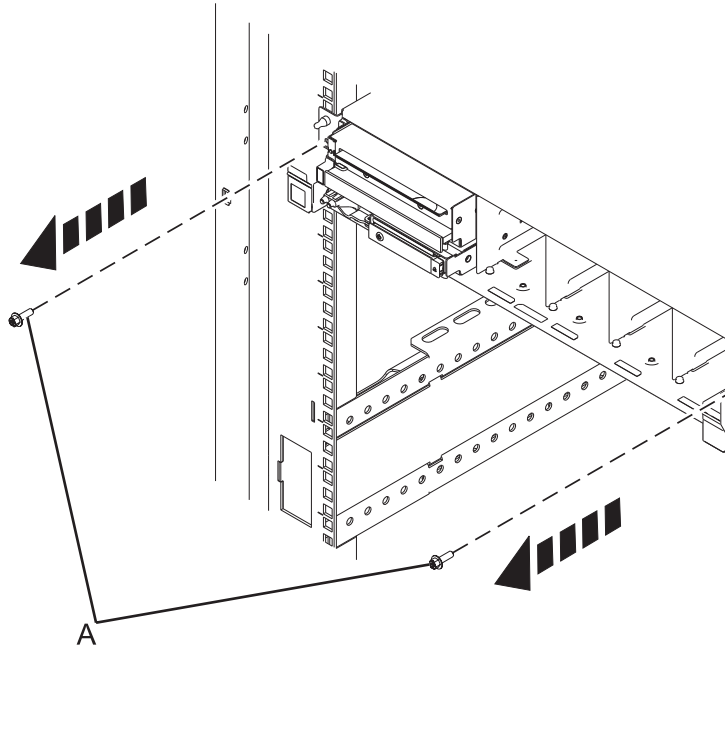

- b. While holding down the system control unit release latch, pull the system control unit out from the rack until the rails are fully extended and locked. When the system control unit rails are fully extended, the rail safety latches lock into place. This action prevents the system control unit from being pulled out too far.

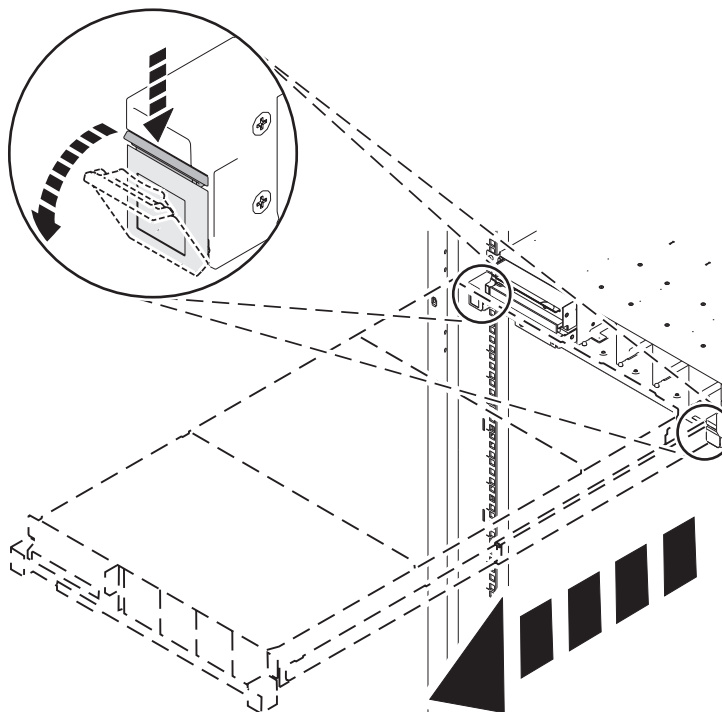

- 10. Secure system control unit with lift tool and position ladder

**Note:** Perform the following step with the help of another SSR only if the slide rails of the system control unit being serviced are above EIA location 29U.

- a. Gently raise the lift tool platform to stably contact the bottom of the drawer, minding not to over force it as it could put upward stress on the slide rails.
- b. While using the ladder, do not lean on or against the system drawer or lift tool during service, and follow safe practices.
- c. Disengage the front two pins by elevating the front of the tilt table using the tilt table handle.
- d. Manually push the system forward slightly away from the rack.
- e. Raise the lift tool to disengage the rear pins.
- f. Push the sliderails in and then level the lift table.
- g. Lower the lift tool to perform the service action at a lower height and move it to a place with clearance for removing front and rear FRUs.



#### 11. Remove DVD Assembly

- a. Move the latch (A) from right to left to unlock the unit.

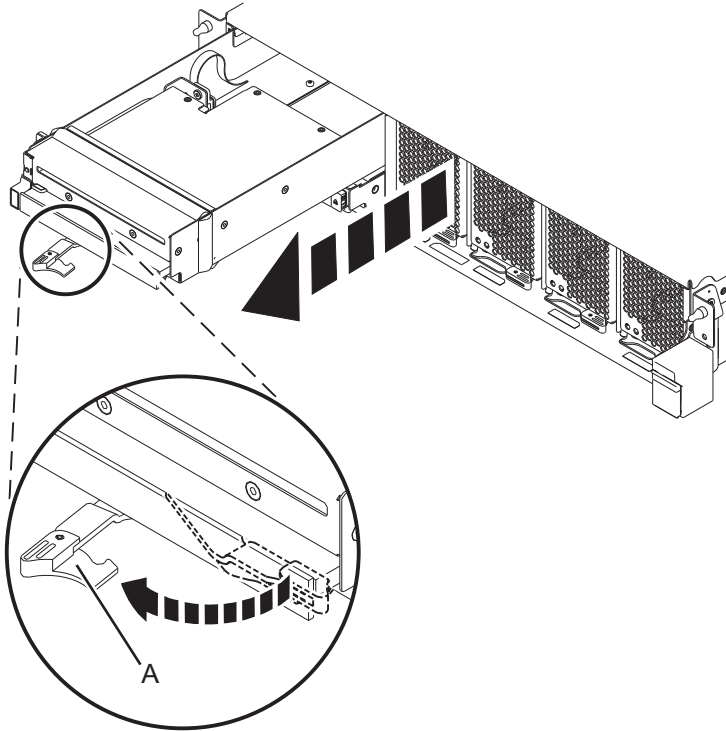

- b. Remove the DVD assembly from the slot.
- c. Place the FRU on an Electrostatic Discharge (ESD) surface.

12. Remove VPD Card

- a. Move the latch (A) from right to left to unlock the unit.
- b. Remove the VPD card from the slot.

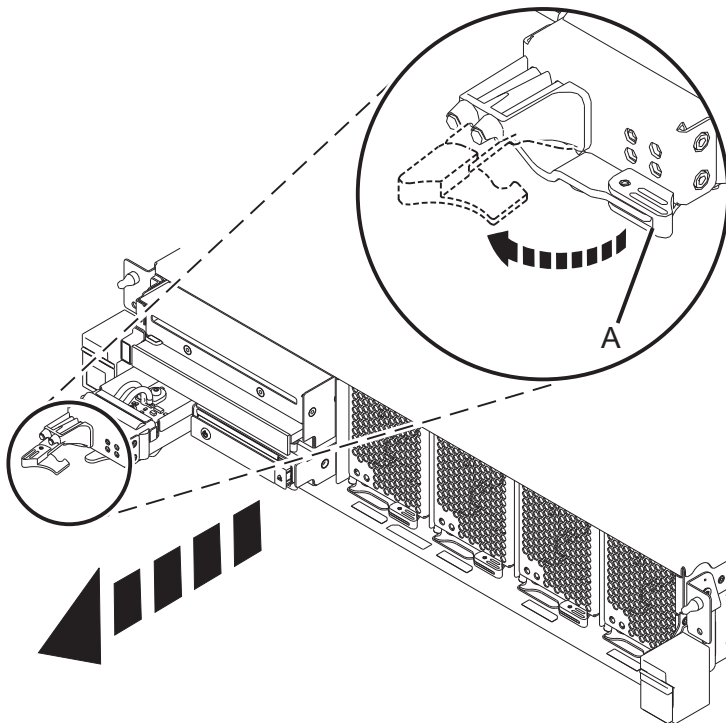

- c. Place the FRU on an Electrostatic Discharge (ESD) surface.

13. Remove OpPanel Assembly
  - a. Move the latch (A) from right to left to unlock the unit.
  - b. Remove the OpPanel from the slot.

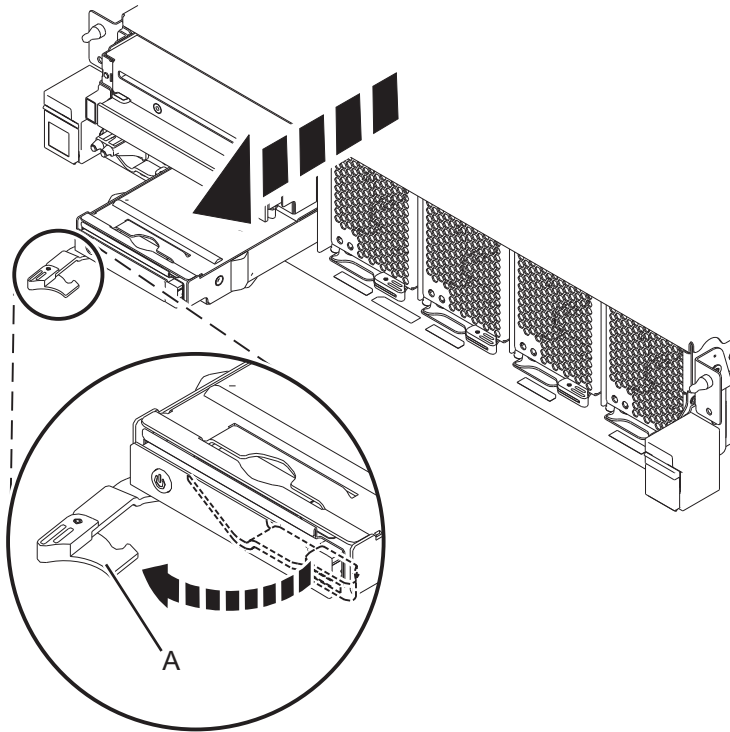

- c. Place the FRU on an Electrostatic Discharge (ESD) surface.
14. Remove all fans
  - a. Note the fan configuration on your System Control Unit.
  - b. If you have a three fan configuration, use the following image for reference:

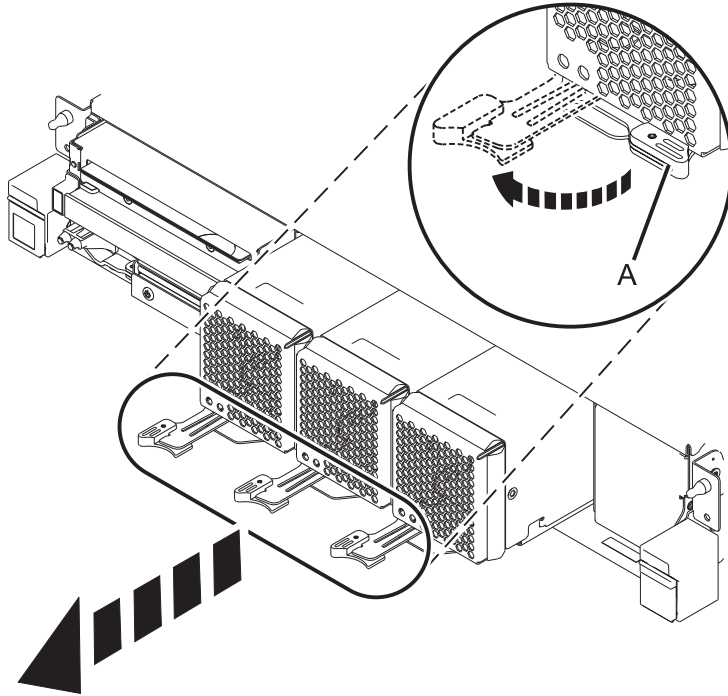

c. If you have a four fan configuration, use the following image for reference:

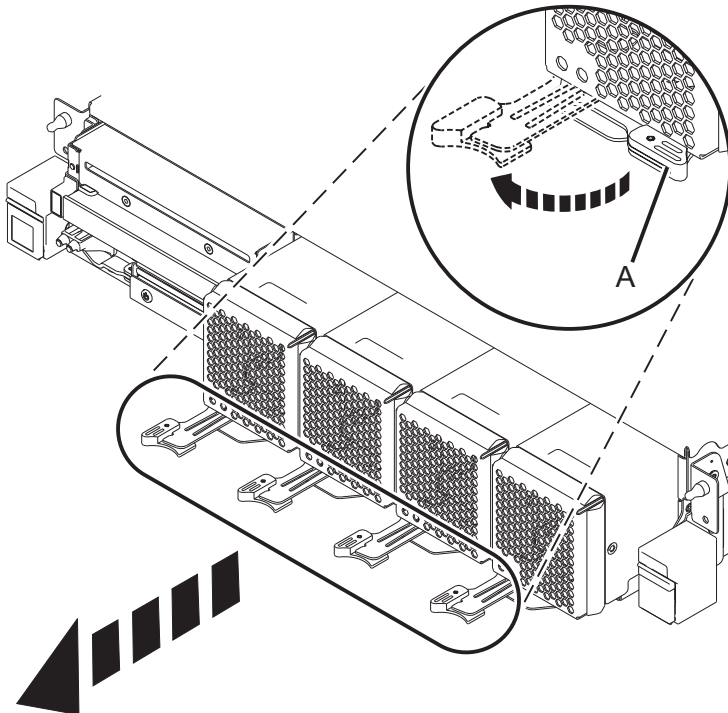

d. Pull the latch (A) to left to unlock the fans from the slots.

**Note:** The latch (A) is held in place by tension on the catch point. You may have to press in on the lever to the left of the latch to release tension in order to unlock it.

e. Slide the fans out of the slots.

- f. The fans are not ESD-sensitive.
- 15. Remove all power cards
  - a. Note the Power Card configuration of your System Control Unit.
  - b. If your Power Card configuration contains two Power Cards, use the following image for reference:

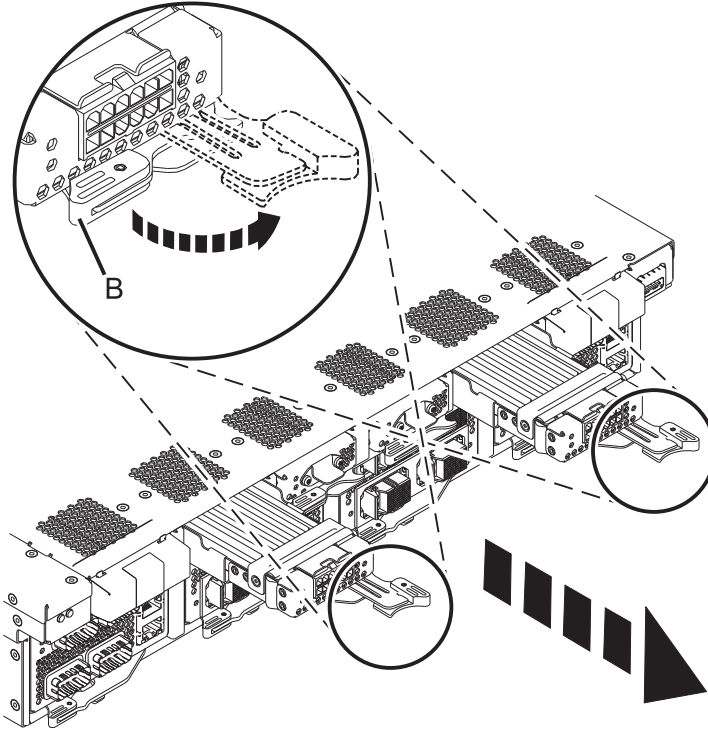

- c. If your Power Card configuration contains four Power Cards, use the following image for reference:

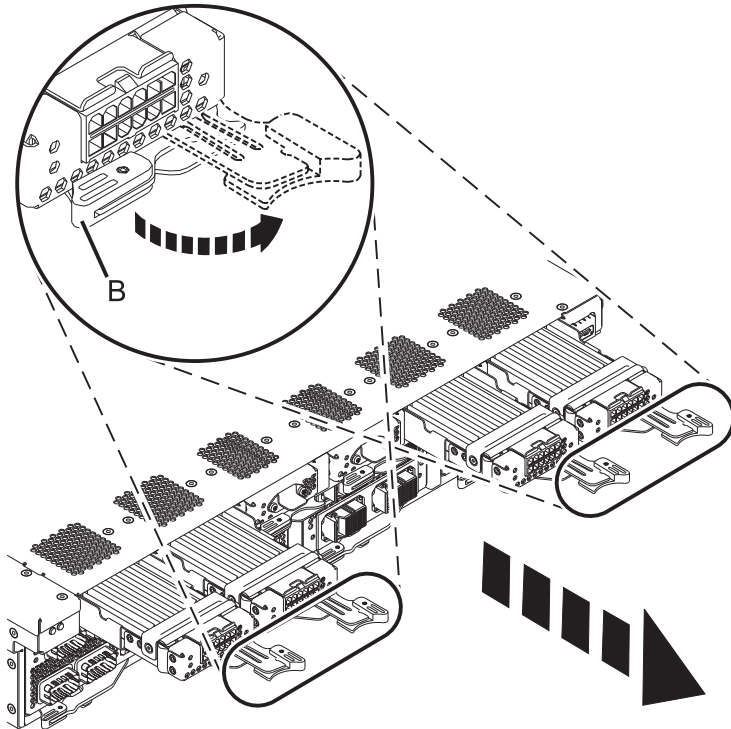

- d. Open the latch (**B**) by pulling the lever to the right.
- e. Slide the cards out from the slot.
- f. Place the FRUs on an Electrostatic Discharge (ESD) surface.

16. Remove all FSP cards

- a. Unlock the FSP cards by moving the locking lever (**C**) from left to right.
- b. Remove the FSP cards by sliding it out of the system enclosure by pulling on the locking lever.

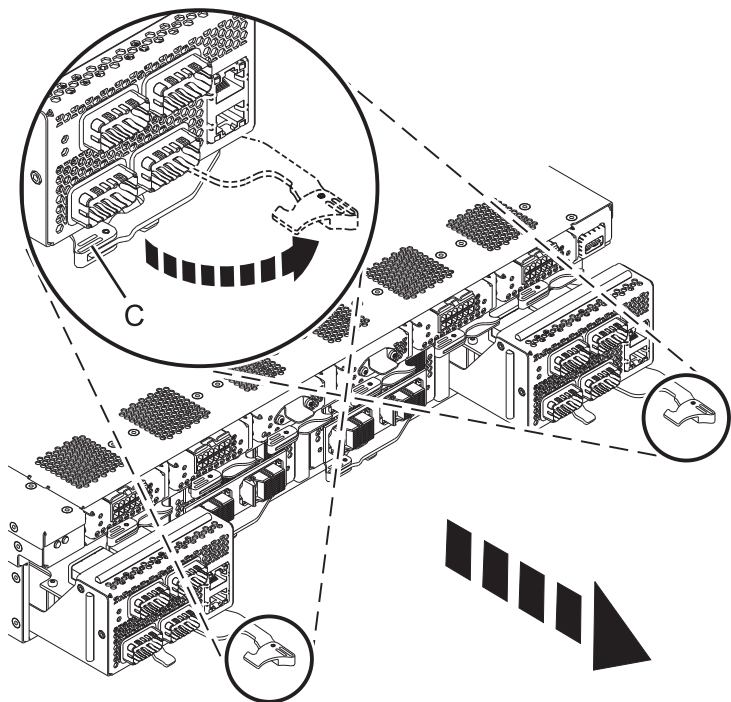



- c. Place the FRUs on an Electrostatic Discharge (ESD) surface.
17. Remove all clock cards
- a. Pull the securing latch **(B)** out and then pull the entire latch lever to the right.
  - b. Pull the cards out of the slots.

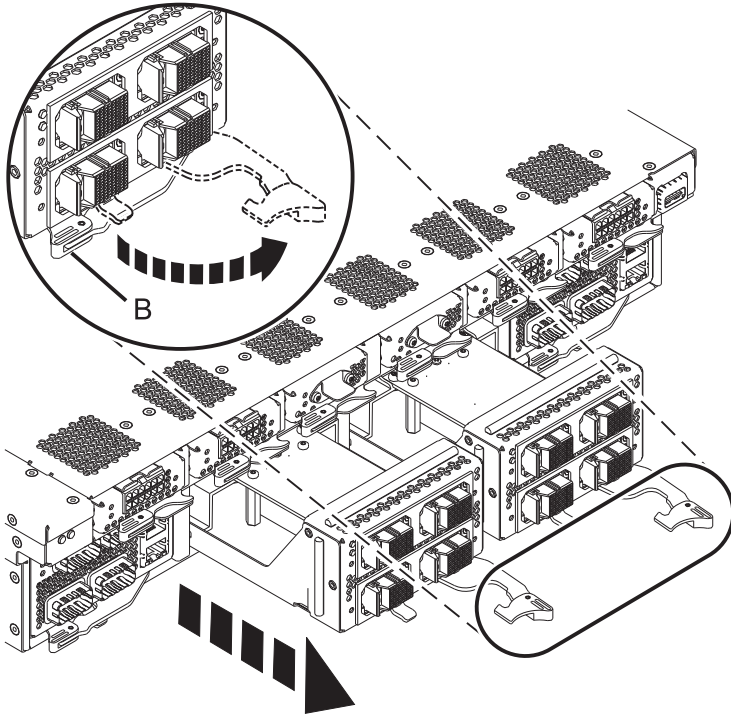

- c. Place the FRUs on an Electrostatic Discharge (ESD) surface.
18. Remove all battery cards
- a. Pull on the securing latch **(A)**, and slide the lever to the right.
  - b. Pull the cards out of the slot.

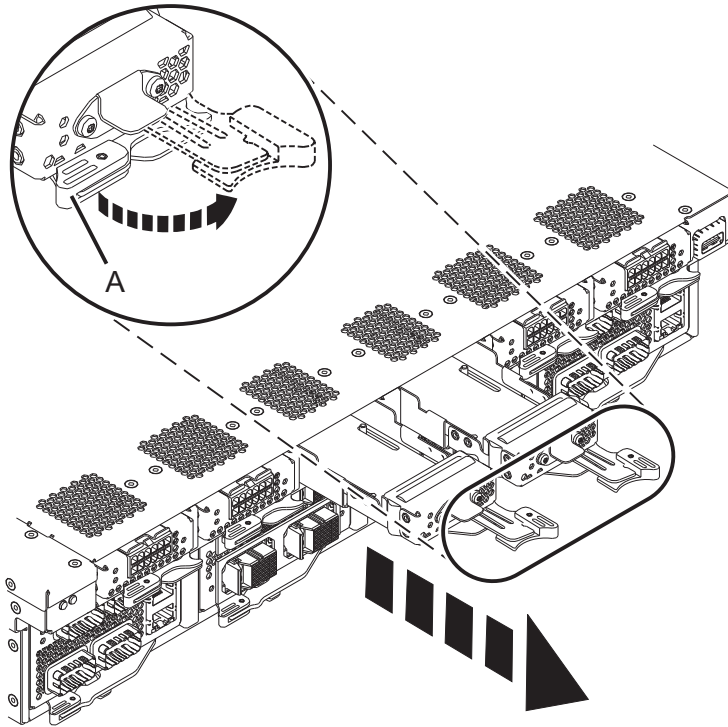

c. Place the FRUs on an Electrostatic Discharge (ESD) surface.

19. Remove Access Cover

a. Lift up on the cover latch and lift the cover off of the system control unit.

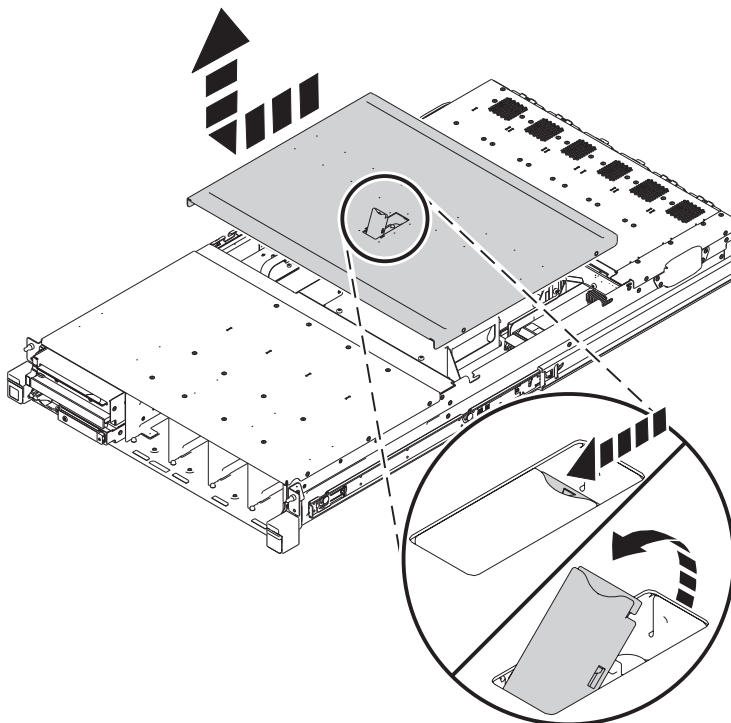

20. Remove planar

a. Remove the 5 screws (A) from the vertical card portion of the planar using a T15 torx driver.

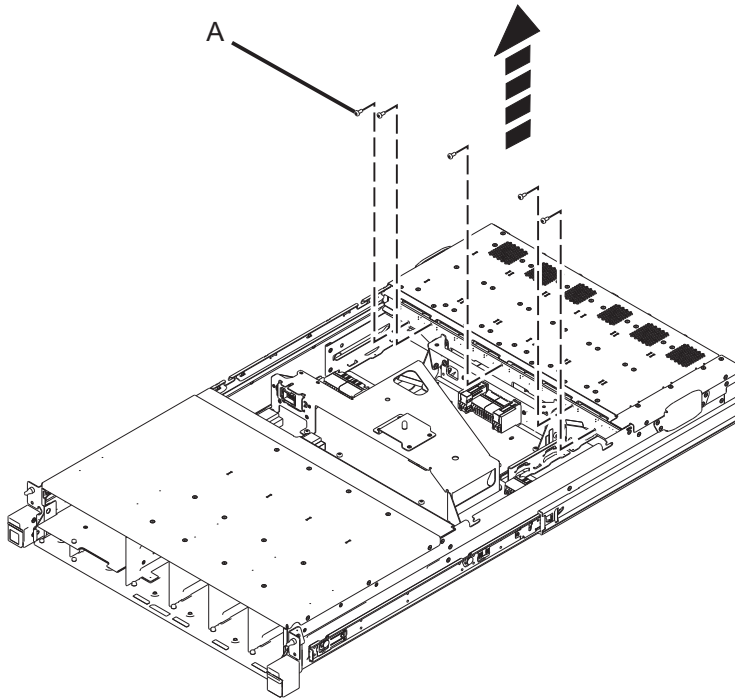

b. Remove the 6 screws (A) from the top side of the planar using a T15 torx driver.

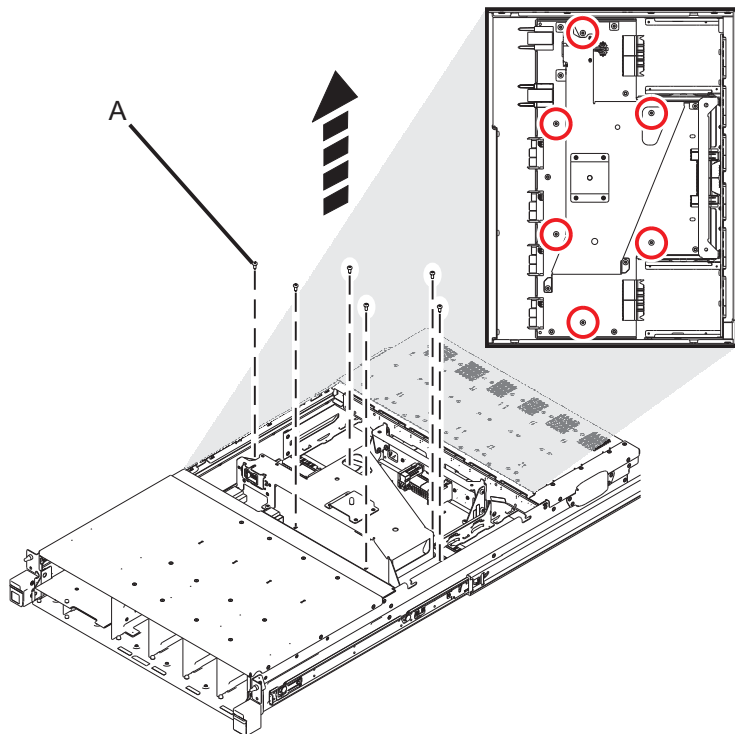

c. Carefully disengage the planar assembly from the chassis and remove from the system.

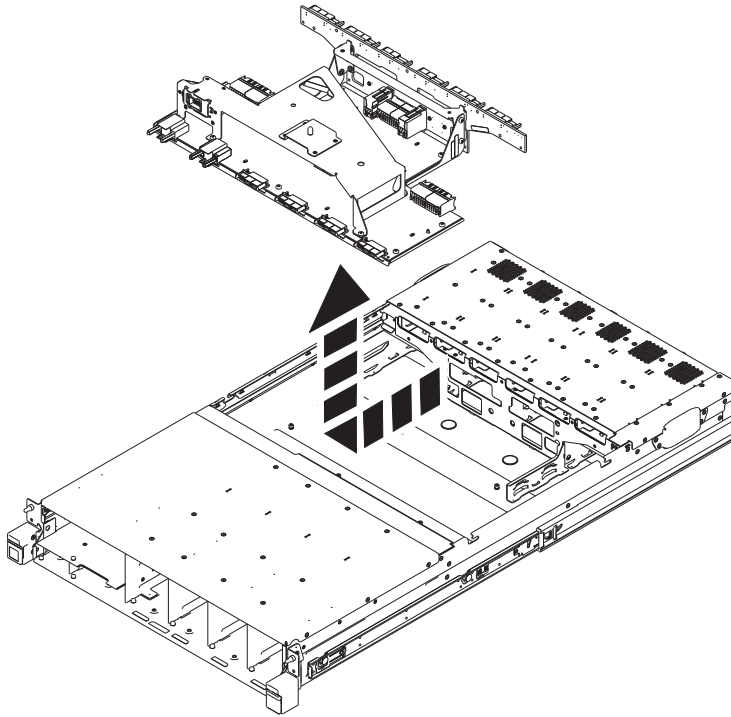

If performing this procedure from a management console, close this web page to continue with the procedure.

---

## Install Planar

To install a planar, complete the following steps:

1. When the node being serviced is above EIA location 29U, the ladders must be used while installing or removing the rear and front cables.
  2. Perform the following procedure on ONLY THE FRU(s) BEING SERVICED. The following images are generic and do not represent the literal location being serviced.
  3. Modifying FRU locations which are not called out for service can have adverse effects on the system, INCLUDING SYSTEM OUTAGE AND LOSS OF DATA.
  4. **CAUTION:** If the system slide rails are installed above EIA location 29U, two Support Services Representatives (SSRs) must perform the procedure together and the following equipment must be used as a safety precaution for servicing: ServerLIFT tool (P/N 74Y4399), two hard hats (P/N 5442867) and two service-qualified ladders (P/N 46G5947 and P/N 00E4866)
1. Install planar
    - a. Carefully align and insert the planar assembly into the chassis.

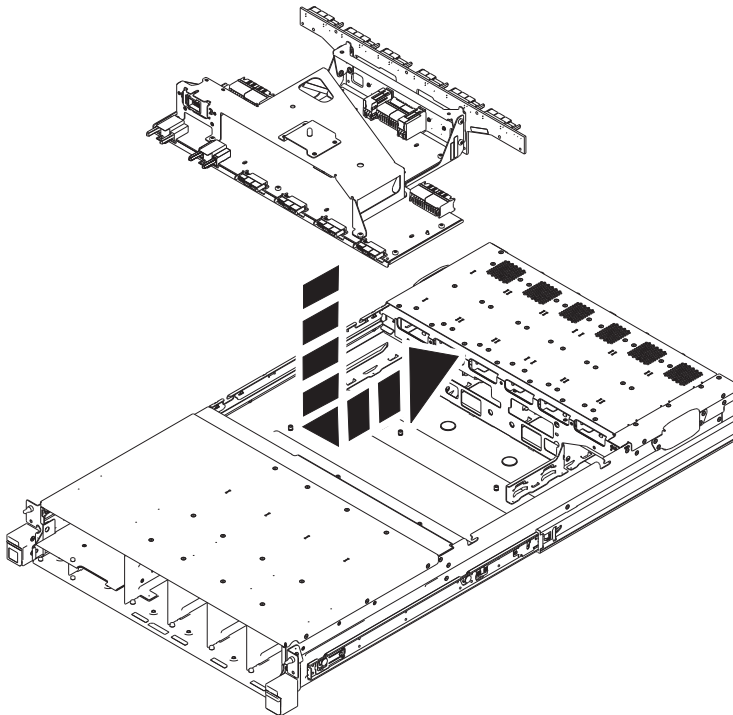

- b. Install the 6 screws (A) from the top side of the planar using a T15 torx driver.

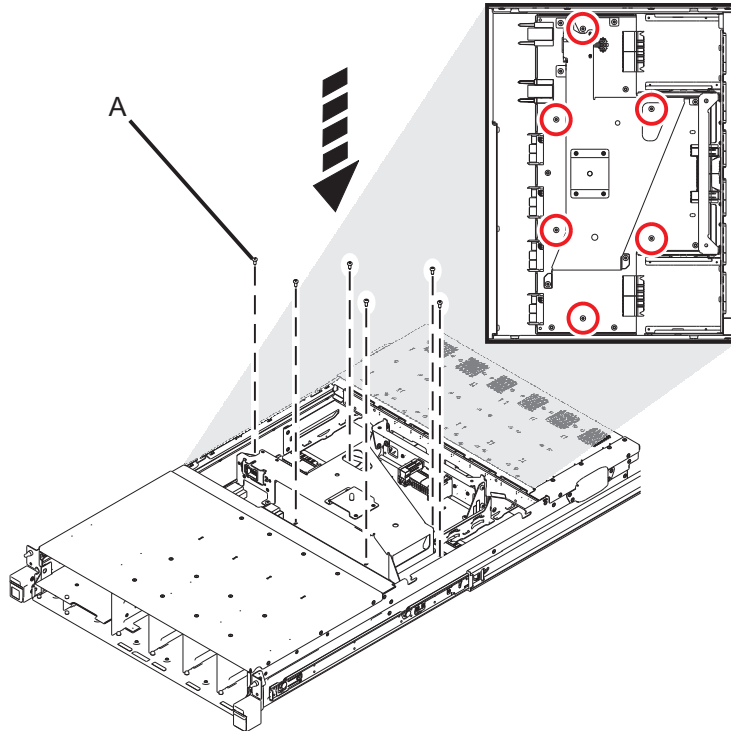

c. Install the 5 screws (A) from the vertical card portion of the planar using a T15 torx driver.

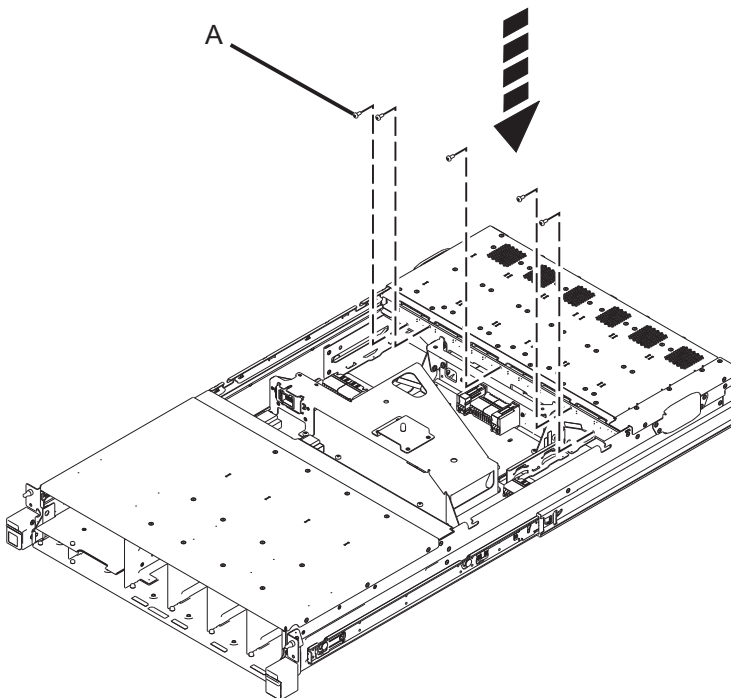

## 2. Install Access Cover

a. Align and place the cover onto the system control unit. Close the latch, which slides the cover into place.

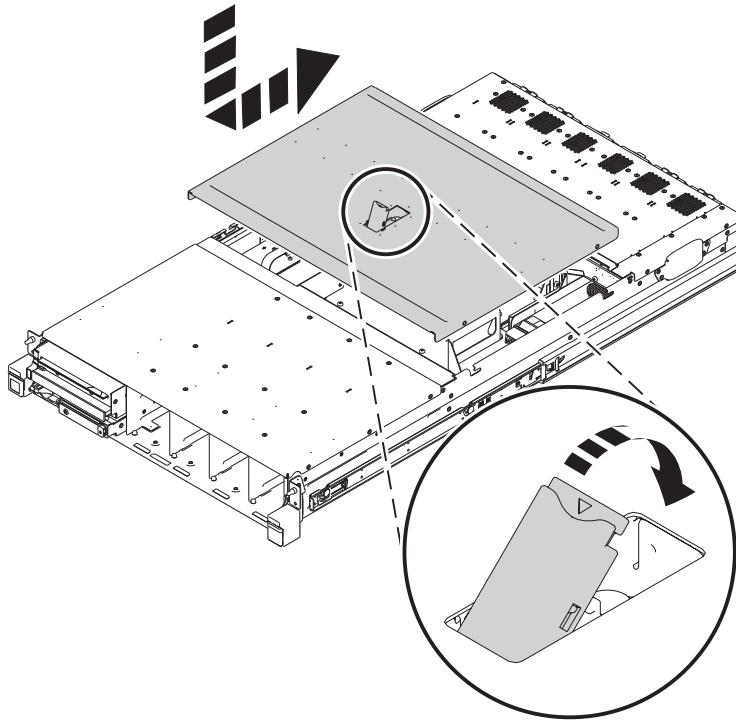

3. Install Battery Cards

- a. Push the cards into the slots.
- b. Push the securing latch **(A)** to the left and make sure it secures into place.

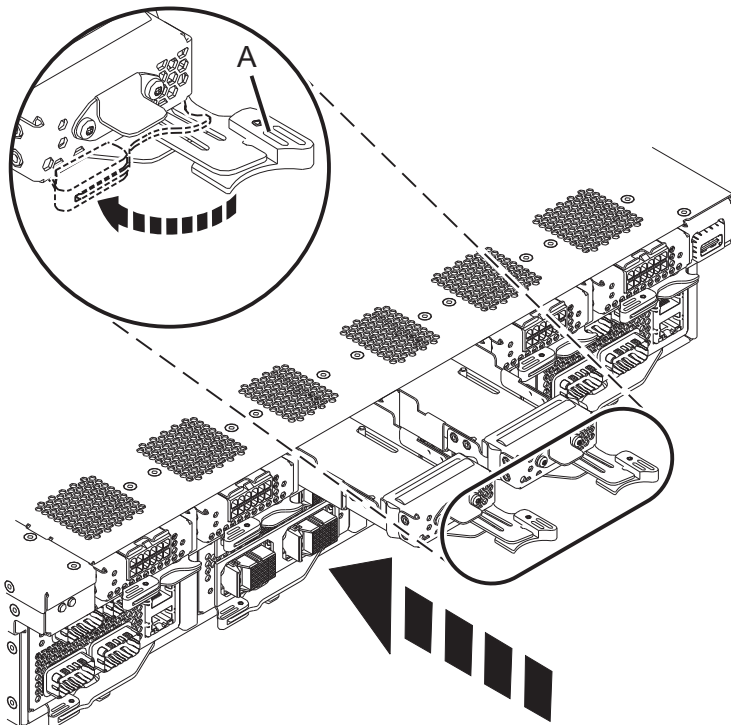

4. Install clock cards

- a. Push the cards into the slots.
- b. Slide the securing latch **(B)** to the left and push it in.

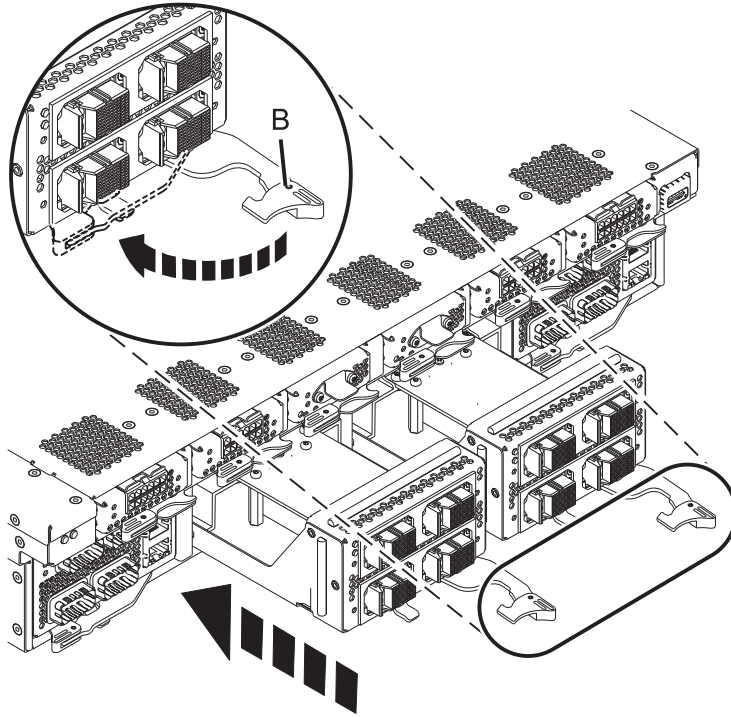

5. Install FSP cards

- a. With the blue handled locking lever in the unlocked position, install the FSP cards by inserting it into the system enclosure and sliding it into place
- b. Lock the FSP cards by moving the blue handled locking lever (C) from right to left.

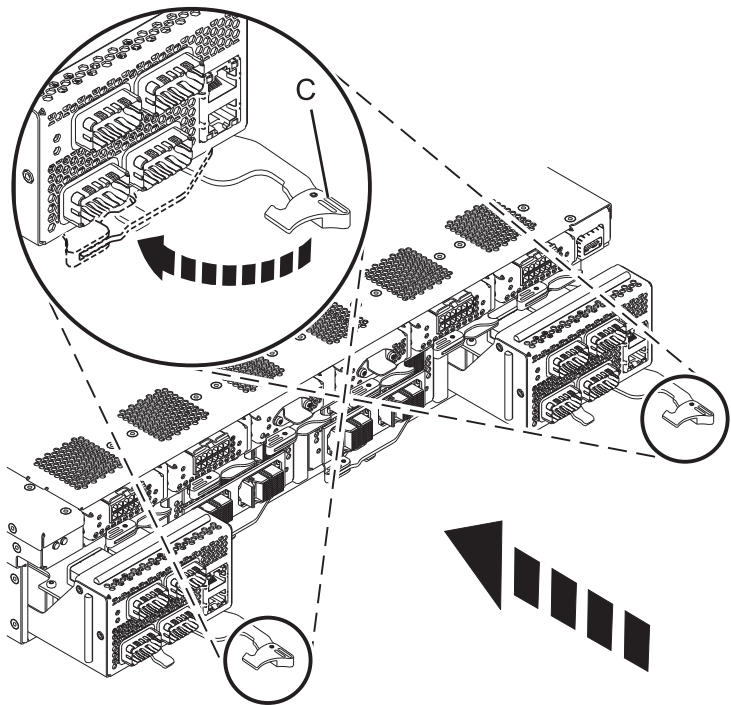

6. Install power cards

- a. Note the Power Card configuration of your System Control Unit.



- b. If your Power card configuration contains two Power Cards, use the following image for reference:

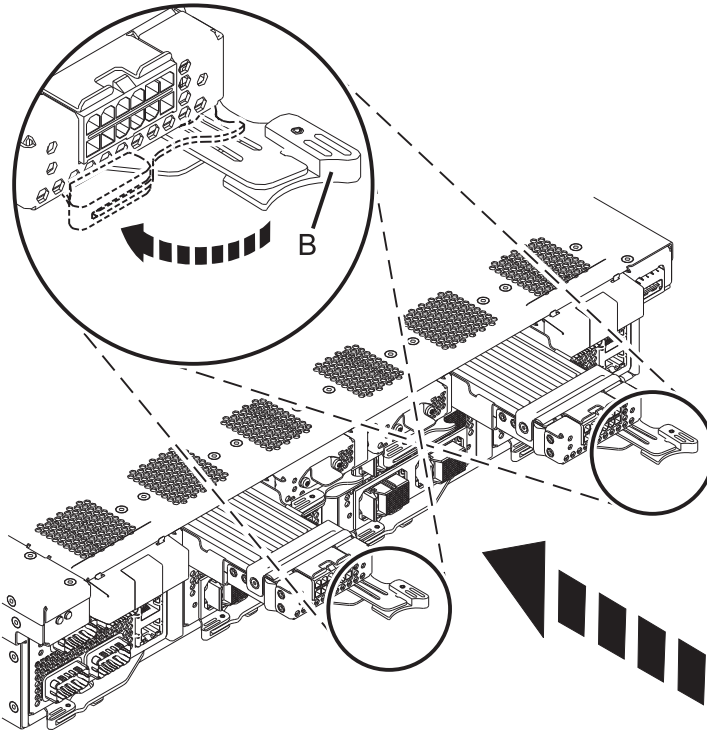

- c. If your Power Card configuration contains four Power Cards, use the following image for reference:

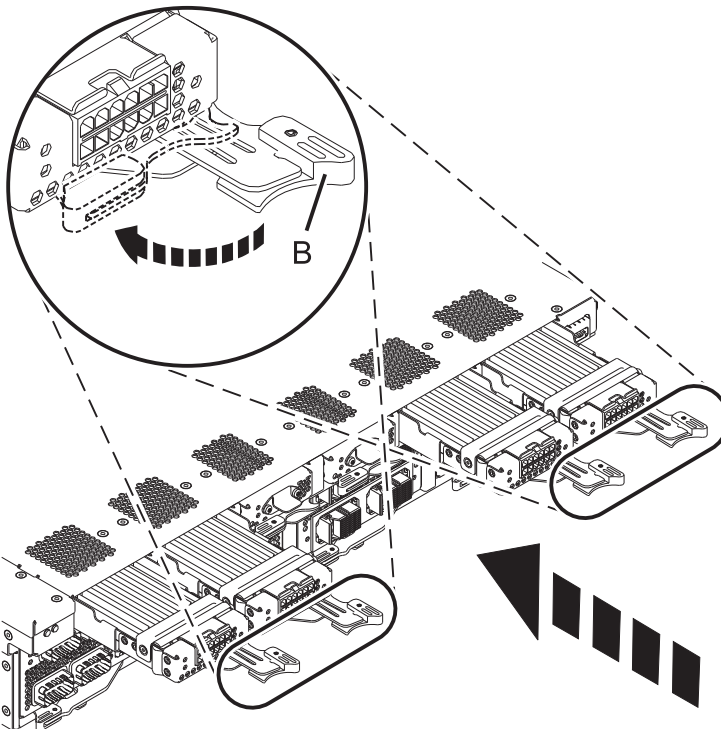

- d. Align the power cards with the slots and push them all the way in.  
e. Secure the power cards by closing the latch (B).

7. Install all fans

- a. Note the fan configuration of your System Control Unit.
- b. If you have a three fan configuration, use the following image for reference:

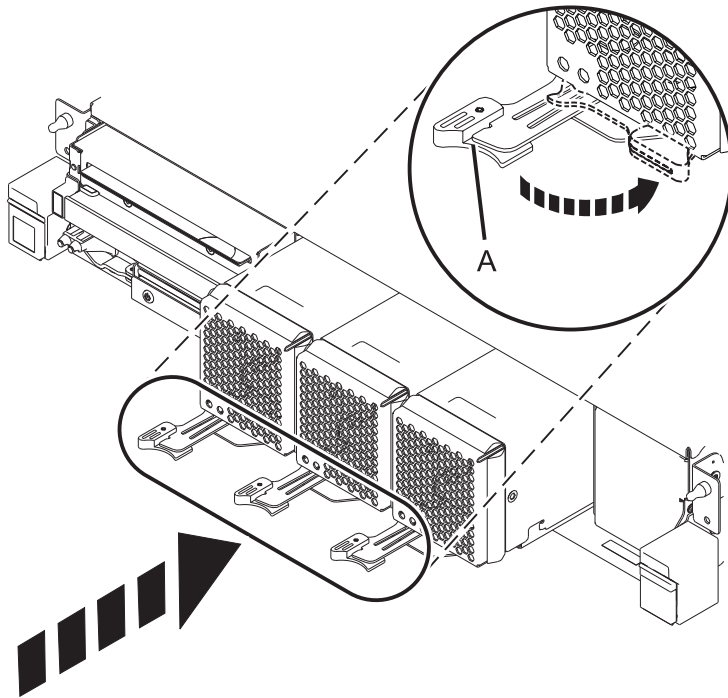

- c. If you have a four fan configuration, use the following image for reference:

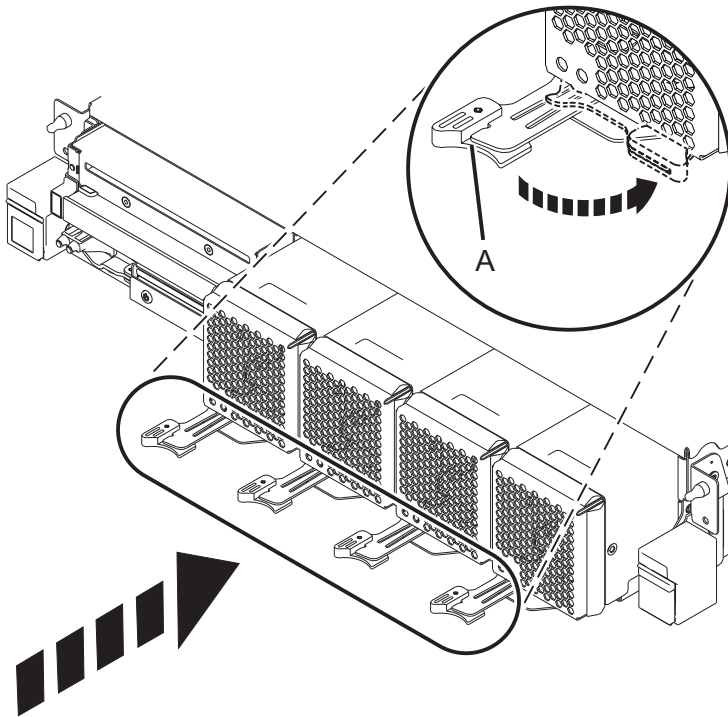

- d. Insert the fans in the slots. When inserting, connector has to clear the sheet metal opening in the rear.
- e. Move the latch (A) to the right to secure the fans.

8. Install OpPanel assembly
  - a. Insert the OpPanel in the slot.
  - b. Move the latch (A) from left to right to lock the unit.

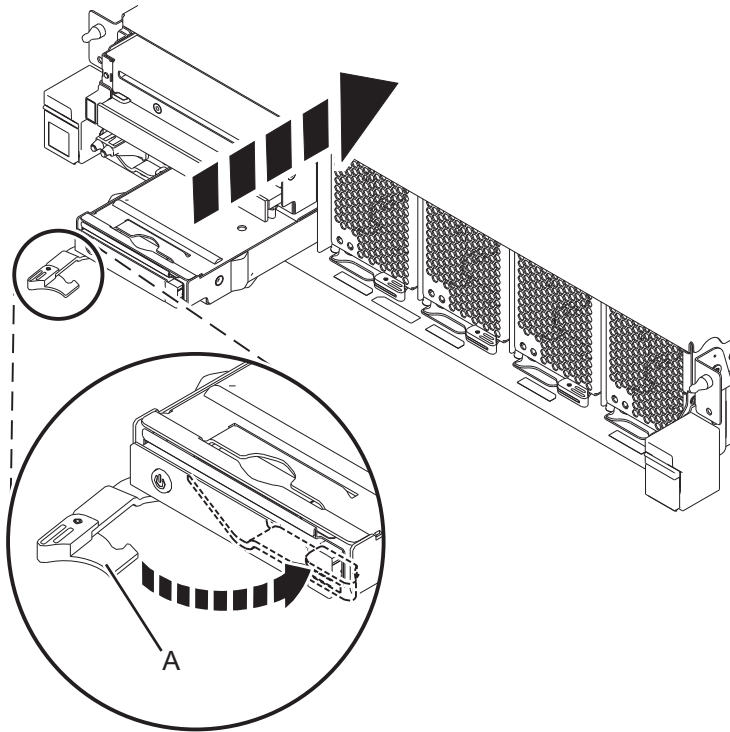

9. Install VPD card
  - a. Insert the VPD card in the slot.
  - b. Move the latch (A) from left to right to lock the unit.

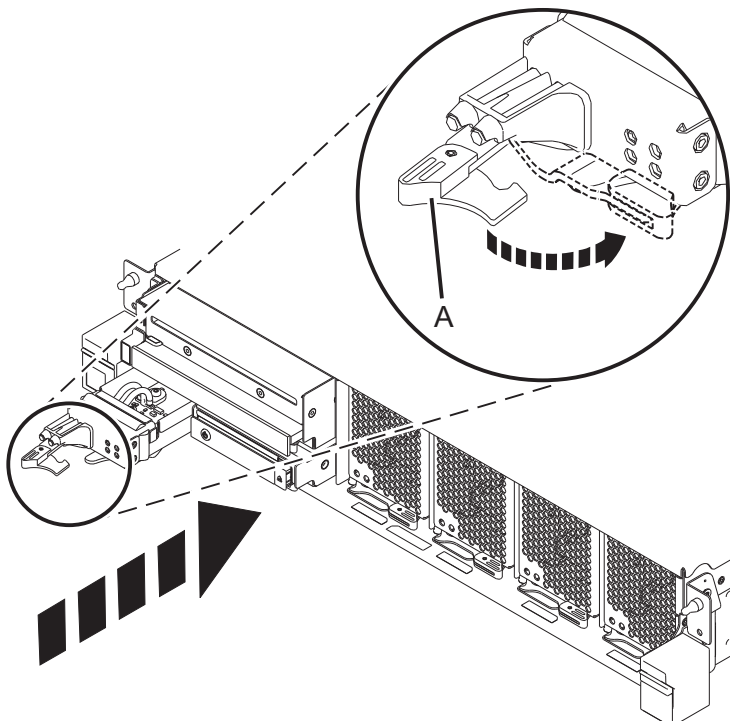

10. Install DVD assembly
  - a. Install the DVD assembly into the slot.
  - b. Move the latch (A) from left to right to unlock the unit.

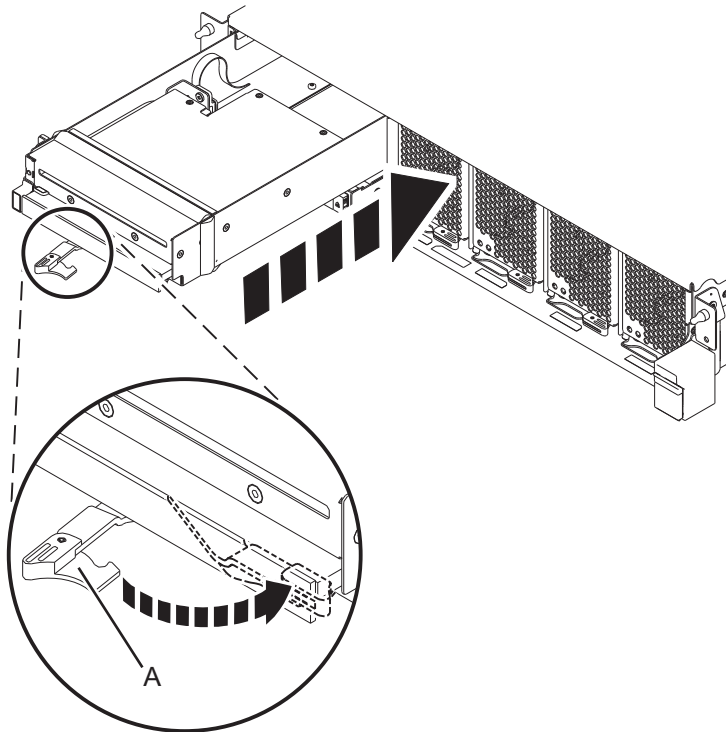

11. Transfer the system control unit onto the extended slide rails

**Note:** With the help of another SSR, follow the procedure below if lift tool and ladders were used to remove the planar from a height above 29U, otherwise skip to the next step.

- a. Raise the lift tool so that the lift tool table is slightly below the bottom of the system drawer to account for the slight downward flex when the drawer is extended out fully on its slides.
- b. Remove any obstacles (cables, packing material, tools, parts, etc.) that may interfere with the transfer.
- c. Position the rear of the system control unit in front of the rack.
- d. Position the system control unit on the tilt table, so that the tilt table handle is at the front of the system control unit.
- e. When standing in front of the rack, the left side of system control unit should align with the left side of the tilt table.

**Note:** Ensure the rack slide rails are pushed in completely and out of the way when you are moving the ServerLIFT.

- f. Release the stabilizer brake, then move the ServerLIFT to the front of the rack.
- g. Rotate the ServerLIFT winch handle clockwise to raise the platform until the three (3) guide pins are just above the height of the slide rails.
- h. Adjust the lift to ensure the system control unit is centered between the two rails when they are extended.
- i. Position the system control unit to have the left side edge (A) aligned with the left edge of the tilt table.
- j. Extend the handle on the tilt table (B) then rotate handle clockwise to tilt the front up.

**Note:** Ensure that the rear pair of guide pins will completely engage the rear slide rail slots when the platform is slightly lowered, but before the middle pair starts to engage.

- k. Release the slide latches and carefully pull the slides outward until the rails are fully extended.

**Note:** Watch the slide rails when moving the ServerLIFT or raising the platform to prevent damage to the extended rails.

- l. Identify the three (3) guide pins on each side of the system control unit and the corresponding slots on the slide rails.
- m. Work with the ServerLIFT winch (up/down) handle and the tilt table angle to lower the chassis to first engage the rear guide pins with the slide rails.
- n. Check slot-pin engagement on both sides, and reseal if necessary.
- o. Verify the rear pins are properly seated, then continue lowering the platform until the middle guide pins drop into the middle slide rail slots.
- p. Continue lowering the platform until the front guide pins are engaged with the front slide rail slots.
- q. Verify all six guide pins are seated properly in their mounting slots.

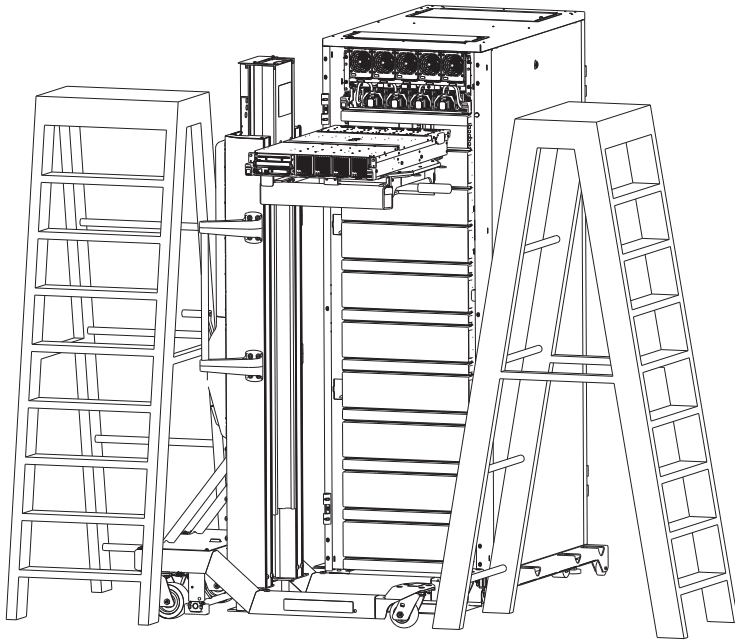

- 12. Put system control unit into operating position
  - a. Lower the lift tool slightly so that the tilt table is not contacting the system node.
  - b. Unlock the rail safety latches (A) by pulling them backwards and push the system control unit back into the rack until the release latch locks into position.

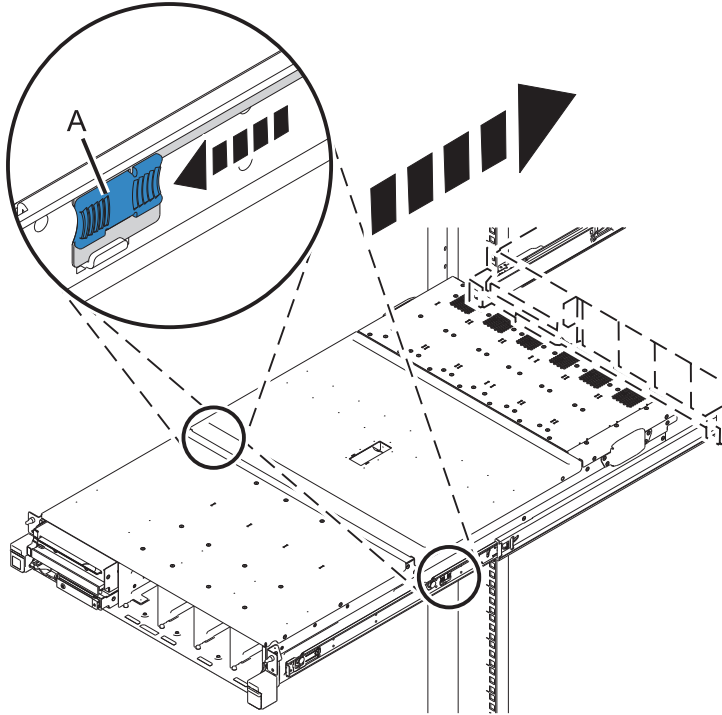

13. Remove ladders and lift tool if used earlier in the procedure.
  - a. If the slide rails of the system control unit being serviced are above EIA location 29U, keep the ladders available as they are required to install remaining items.
  - b. Move the ladders away.
  - c. Remove ServerLIFT Tool.

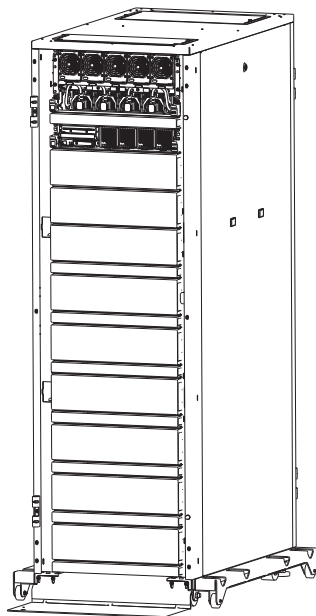

14. Install clock flex cables

- a. **Note:** The clock flex cables are point to point cables designed for their fixed locations and should not be stretched when installing. Stretching the cable during installation may lead to misplugging and bent pins.
- b. If you have a single node system configuration, use the diagram and the *Single System Node to System Control Unit* Table below to determine point to point cabling for the clock flex cables.

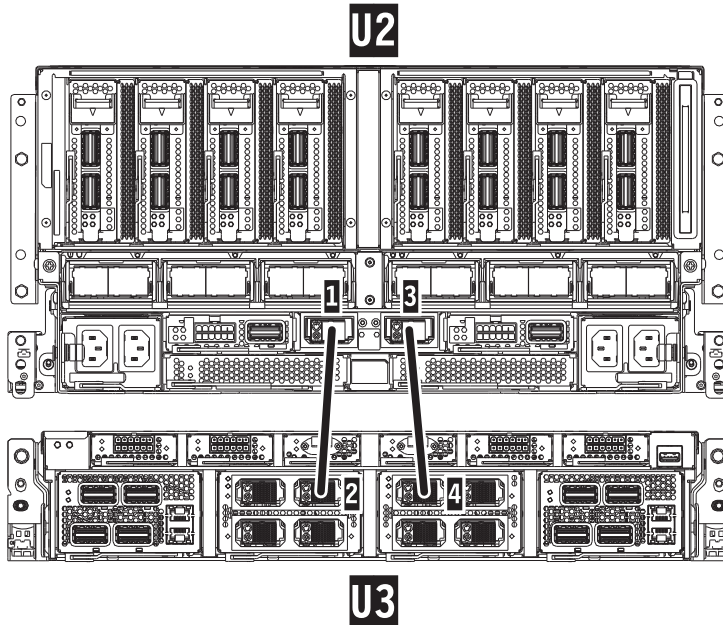

Table 1. Single System Node to System Control Unit Clock Card Cabling

Index Number	From: (U-Loc)	Cable Type	Index Number	To: (U-Loc)
1	U2: P1-T7	Short Clock Flex Cable (Left)	2	U3: P1-C8-T2
3	U2: P1-T8	Short Clock Flex Cable (Right)	4	U3: P1-C9-T1

- c. If you have a two node system configuration, use the diagram and the *Two System Nodes to System Control Unit* Table below to determine point to point cabling for the clock flex cables.

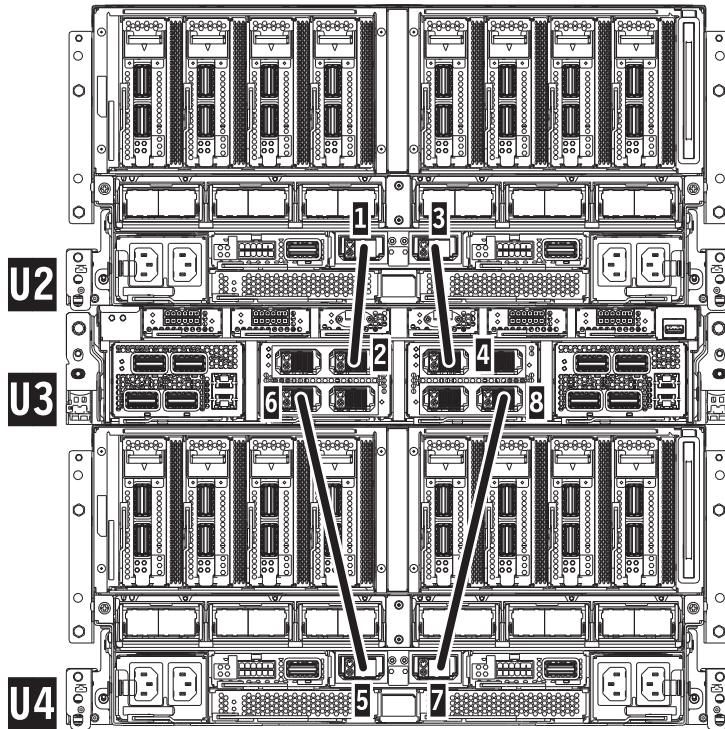

Table 2. Two System Nodes to System Control Unit Clock Card Cabling

Index Number	From: (U-Loc)	Cable Type	Index Number	To: (U-Loc)
1	U2: P1-T7	Short Clock Flex Cable (Left)	2	U3: P1-C8-T2
3	U2: P1-T8	Short Clock Flex Cable (Right)	4	U3: P1-C9-T1
5	U4: P1-T7	Long Clock Flex Cable (Left)	6	U3: P1-C8-T3
7	U4: P1-T8	Long Clock Flex Cable (Right)	8	U3: P1-C9-T4

- d. If you have a three node system configuration, use the diagram and the *Three System Node to System Control Unit* Table below to determine point to point cabling for the clock flex cables.



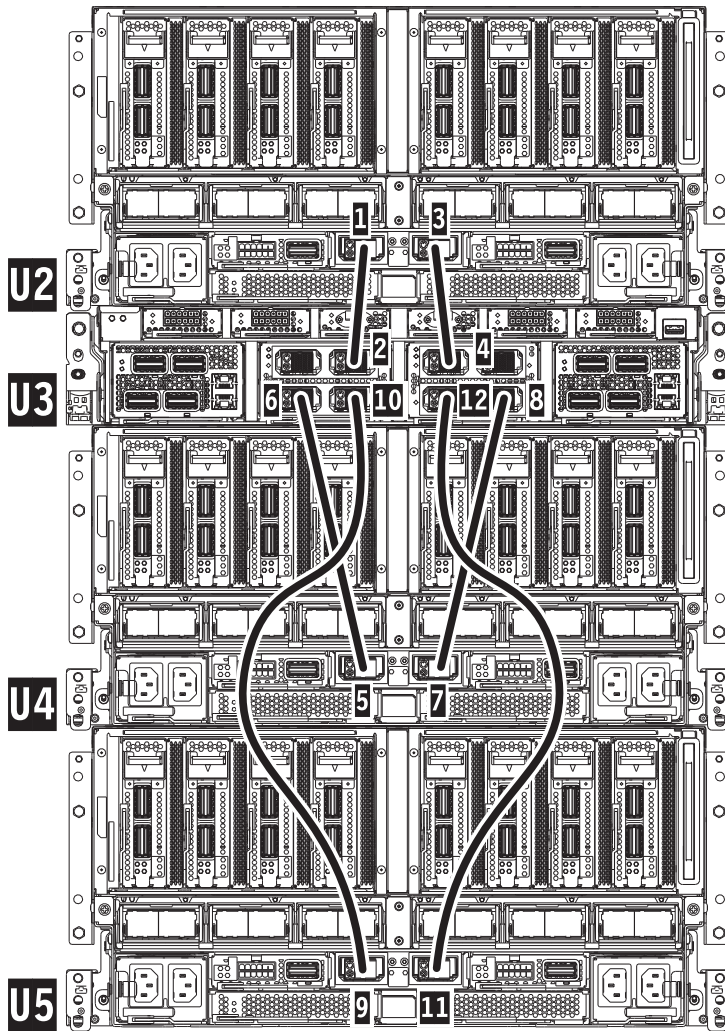

Table 3. Three System Node to System Control Unit Clock Card Cabling

Index Number	From: (U-Loc)	Cable Type	Index Number	To: (U-Loc)
1	U2: P1-T7	Short Clock Flex Cable (Left)	2	U3: P1-C8-T2
3	U2: P1-T8	Short Clock Flex Cable (Right)	4	U3: P1-C9-T1
5	U4: P1-T7	Long Clock Flex Cable (Left)	6	U3: P1-C8-T3
7	U4: P1-T8	Long Clock Flex Cable (Right)	8	U3: P1-C9-T4
9	U5: P1-T7	Long Clock Flex Cable (Left)	10	U3: P1-C8-T4
11	U5: P1-T8	Long Clock Flex Cable (Right)	12	U3: P1-C9-T3

- e. If you have a four node system configuration, use the diagram and the *Four System Node to System Control Unit* Table below to determine point to point cabling for the clock flex cables.

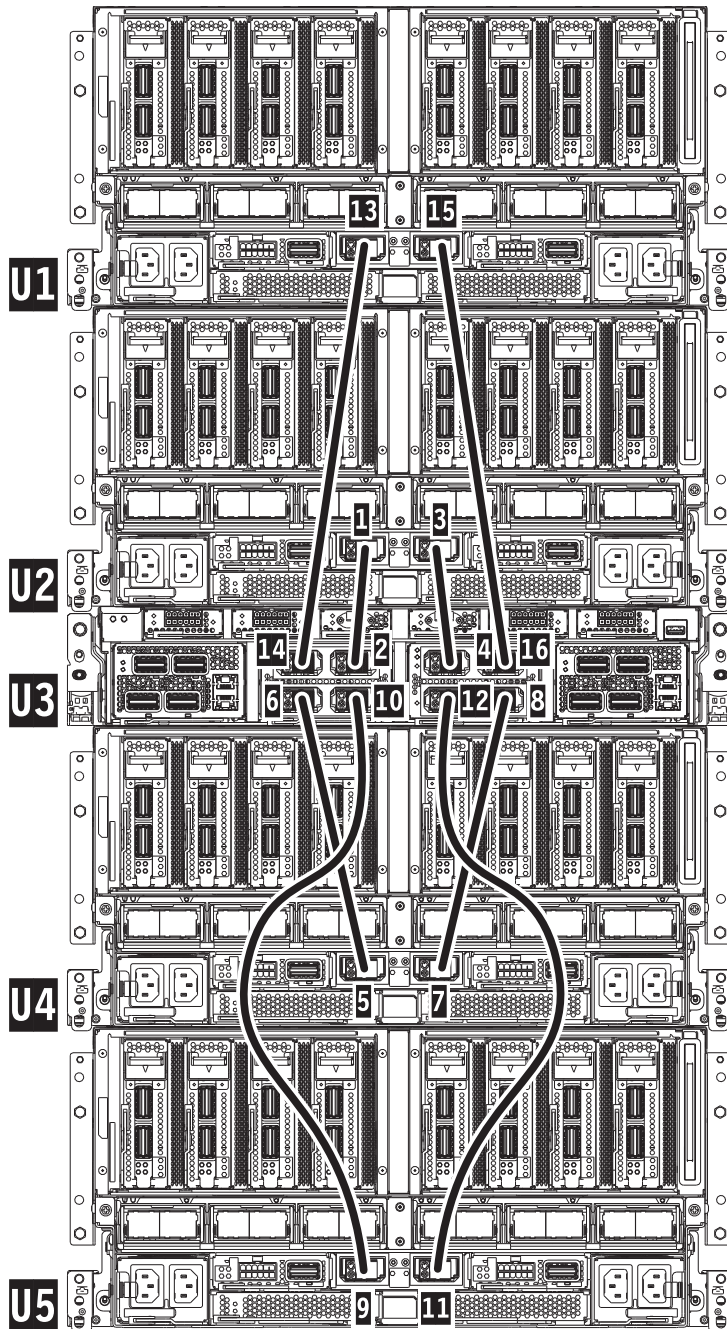

Table 4. Four System Node to System Control Unit Clock Card Cabling

Index Number	From: (U-Loc)	Cable Type	Index Number	To: (U-Loc)
1	U2: P1-T7	Short Clock Flex Cable (Left)	2	U3: P1-C8-T2
3	U2: P1-T8	Short Clock Flex Cable (Right)	4	U3: P1-C9-T1
5	U4: P1-T7	Long Clock Flex Cable (Left)	6	U3: P1-C8-T3
7	U4: P1-T8	Long Clock Flex Cable (Right)	8	U3: P1-C9-T4

Table 4. Four System Node to System Control Unit Clock Card Cabling (continued)

Index Number	From: (U-Loc)	Cable Type	Index Number	To: (U-Loc)
9	U5: P1-T7	Long Clock Flex Cable (Left)	10	U3: P1-C8-T4
11	U5: P1-T8	Long Clock Flex Cable (Right)	12	U3: P1-C9-T3
13	U1: P1-T7	Long Clock Flex Cable (Left)	14	U3: P1-C8-T1
15	U1: P1-T8	Long Clock Flex Cable (Right)	16	U3: P1-C9-T2

- f. Attach the clock card cables (A) to their original positions.

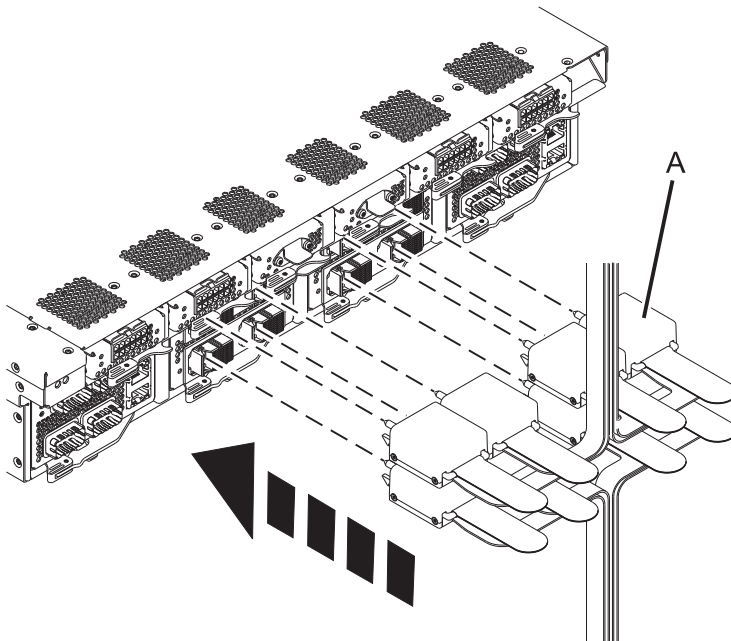

15. Install FSP and HMC cables

- a. Reconnect the FSP cables (A), pushing them in until they lock in place.
- b. Lightly pull on the FSP cables from both attachment points to ensure it is locked into place. The cables should be firmly attached to the system.
- c. Reconnect the HMC cables (B), pushing it in until it locks in place.

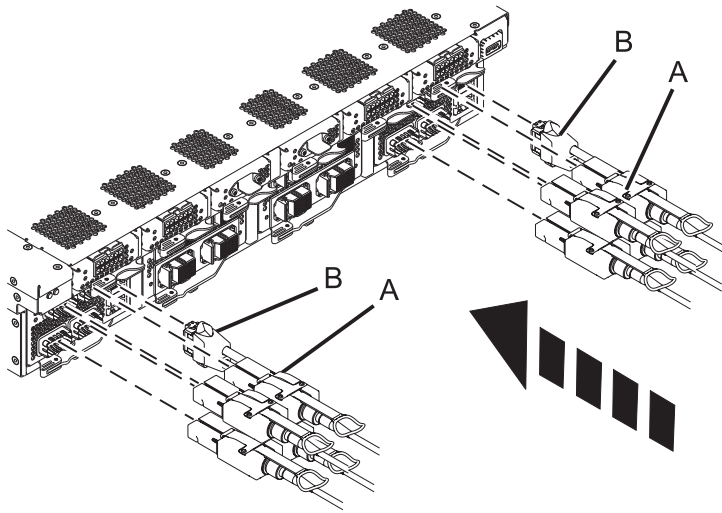

16. Install UPIC cables

- a. Note the Power Card configuration of your System Control Unit.
- b. If your Power card configuration contains two Power Cards, use the following image for reference:

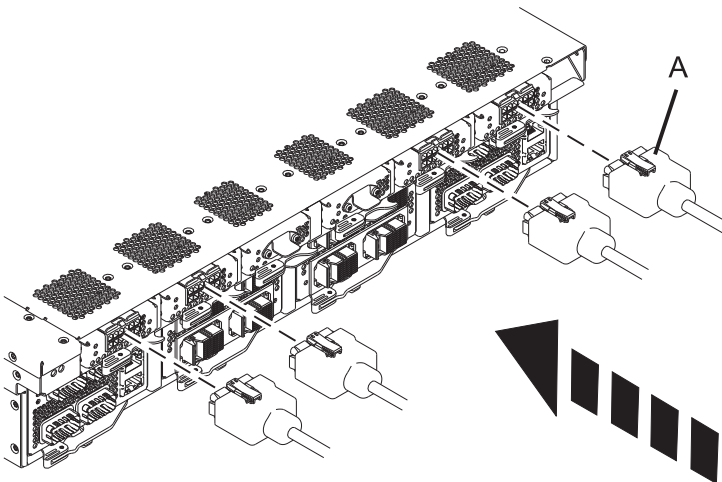

- c. If your Power Card configuration contains four Power Cards, use the following image for reference:

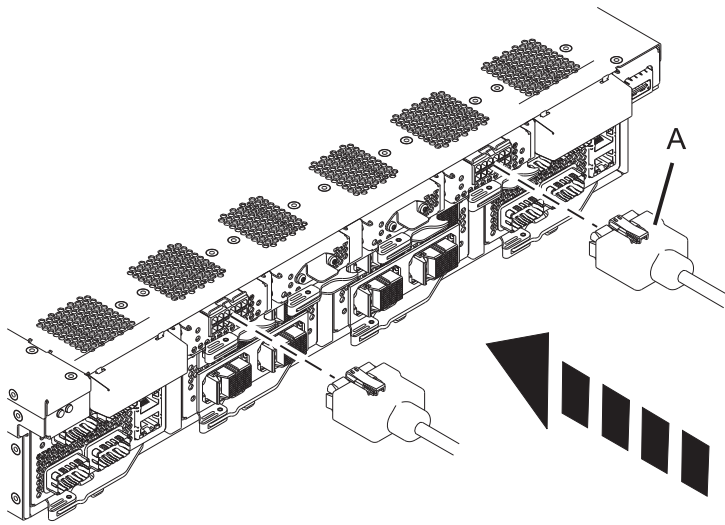

- d. Connect the UPIC cable **(A)** to the back of the power card.
  - e. If removed earlier, slide the plastic cable lock cover over the UPIC cable clips
17. Install the USB cable
- a. If previously removed, install the USB cable

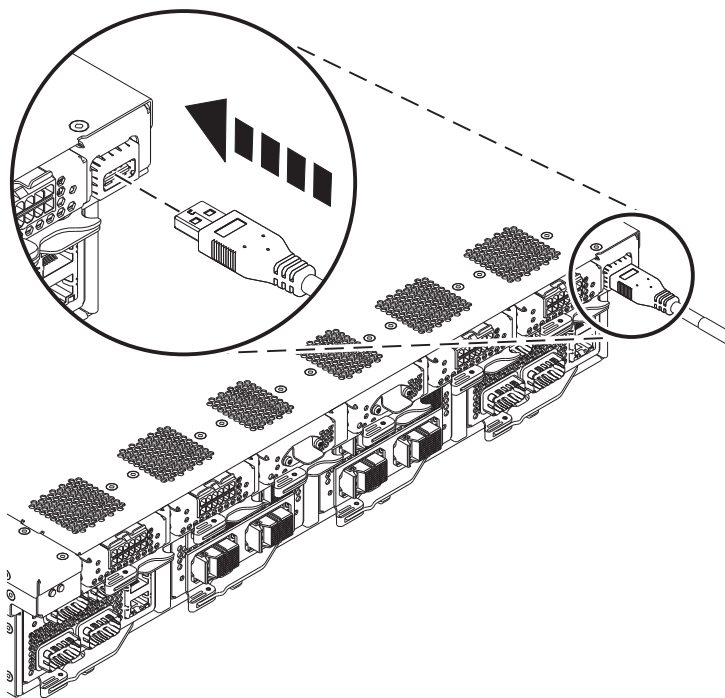

- 18. Connect any power supply cords, which were removed at the start of the procedure, to the affected system node(s).

19. Install front cover on the system control unit
- If previously removed, install and tighten the screws (A) that secure the system control unit to the rack.

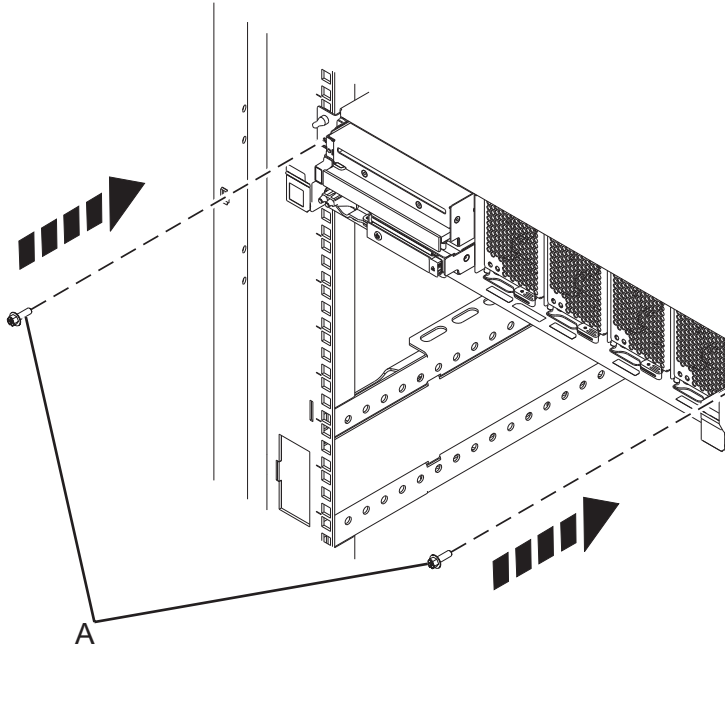

- Check if the trifold card is present. If so, remove the card.
- Install the front cover (A).

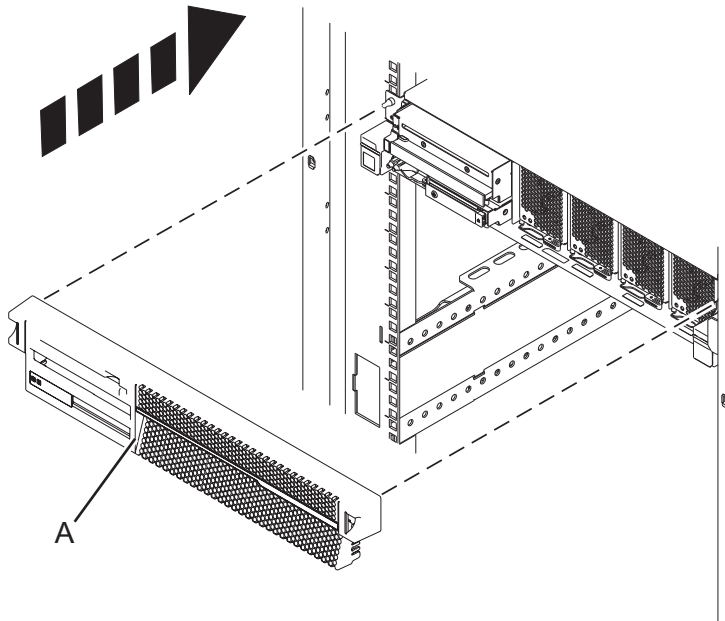

- d. If the trifold card was removed, replace the card into its original position.
20. Install front bezel on the system node
- a. Install the front bezel (A) on all system nodes which share the same system control unit that is being serviced.

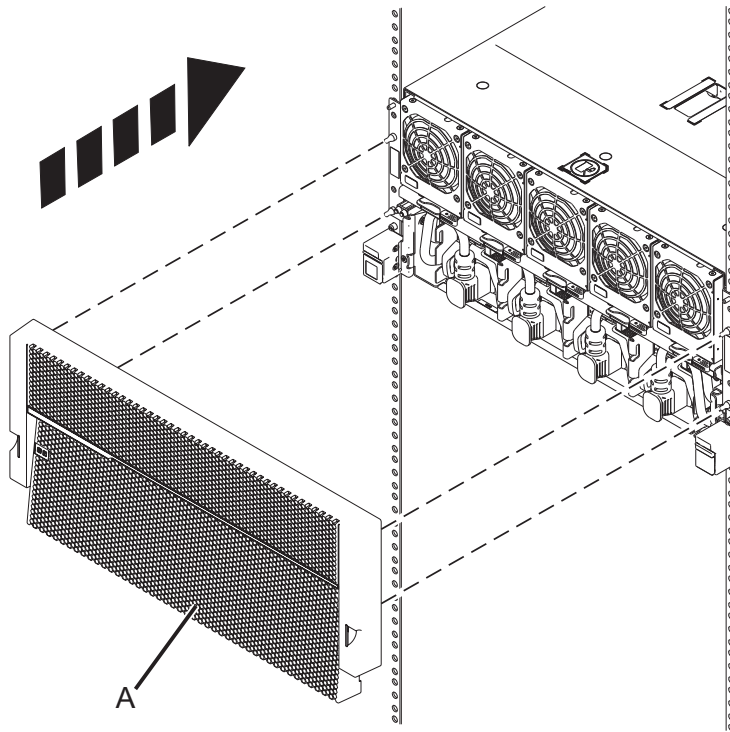

21. Set the time of day
- a. Wait for the FSP to connect and for ASMI to become available.
  - b. On the ASMI Welcome pane, specify your user ID and password, and click Log In.
  - c. In the navigation area, expand System Configuration.
  - d. Select Time of Day. If the system is powered off, the right pane displays a form that shows the current date (month, day, and year) and time (hours, minutes, seconds).
  - e. Change either the date value or the time value or both, and click Update Time Of Day.

If performing this procedure from a management console, close this web page to continue with the procedure.









Printed in USA