

Power Systems

*Managing devices for the 8202-E4B,
8202-E4C, 8202-E4D, 8205-E6B,
8205-E6C, or 8205-E6D*

IBM

Power Systems

*Managing devices for the 8202-E4B,
8202-E4C, 8202-E4D, 8205-E6B,
8205-E6C, or 8205-E6D*

IBM

Note

Before using this information and the product it supports, read the information in "Safety notices" on page v, "Notices" on page 117, the *IBM Systems Safety Notices* manual, G229-9054, and the *IBM Environmental Notices and User Guide*, Z125-5823.

This edition applies to IBM Power Systems™ servers that contain the POWER7 processor and to all associated models.

© Copyright IBM Corporation 2010, 2014.

US Government Users Restricted Rights – Use, duplication or disclosure restricted by GSA ADP Schedule Contract with IBM Corp.

Contents

Safety notices	v
Managing devices for the 8202-E4B, 8202-E4C, 8202-E4D, 8205-E6B, 8205-E6C, or 8205-E6D	1
Managing tape drives	1
Tape drives	1
Tape drive media	3
Preparing the tape drive for installation	8
1.5/3.0 TB Ultrium 5 SAS tape drive (FC 5638)	9
Eject button functions on the tape drive (FC 5638)	10
Status lights (FC 5638)	11
Tape cartridges (FC 5638)	21
Setting the write-protect switch	21
Cleaning the tape drive (FC 5638)	22
Loading and unloading tape cartridges	23
Loading a tape cartridge	23
Unloading a tape cartridge	23
Maintenance mode (FC 5638)	24
Resetting the tape drive	26
Performing the internal self-test (FC 5638)	26
2.5/6.25 TB Ultrium 6 SAS tape drive (FC EU11)	28
Eject button functions on the tape drive (FC EU11)	29
Status lights (FC EU11)	30
Tape cartridges (FC EU11)	40
Setting the write-protect switch	40
Cleaning the tape drive (FC EU11)	41
Loading and unloading tape cartridges	42
Loading a tape cartridge	42
Unloading a tape cartridge	42
Maintenance mode (FC EU11)	43
Resetting the tape drive	45
Performing the internal self-test (FC EU11)	45
36/72 GB Data72 4 mm internal tape drive (FC 6258 or 5907)	47
Cleaning the tape drive (FC 6258 or 5907)	48
Loading and unloading tape cartridges	49
Loading a tape cartridge	49
Unloading a tape cartridge	49
Setting the write-protect switch (FC 6258 or 5907)	49
Status lights (FC 6258 or 5907)	50
Tape cartridges (FC 6258 or 5907)	52
Resetting the tape drive	53
80/160 GB DAT160 SAS tape drive (FC 5619)	53
Cleaning the tape drive (FC 5619)	55
Loading and unloading tape cartridges	56
Loading a tape cartridge	56
Unloading a tape cartridge	56
Setting the write-protect switch (FC 5619)	56
Status lights (FC 5619)	57
Tape cartridges (FC 5619)	59
Resetting the tape drive	60
80/160 GB DAT160 USB tape drive (FC EU16)	60
Cleaning the tape drive (FC EU16)	61
Loading and unloading tape cartridges	62
Loading a tape cartridge	62
Unloading a tape cartridge	62

Setting the write-protect switch (FC EU16)	63
Status lights (FC EU16)	63
Tape cartridges (FC EU16)	66
Resetting the tape drive	66
160/320 GB DAT320 SAS tape drive (FC 5661).	67
Cleaning the tape drive (FC 5661)	68
Loading and unloading tape cartridges	69
Loading a tape cartridge	69
Unloading a tape cartridge	69
Setting the write-protect switch (FC 5661)	70
Status lights (FC 5661).	70
Tape cartridges (FC 5661).	73
Resetting the tape drive	73
160/320 GB DAT320 USB tape drive (FC 5673)	74
Cleaning the tape drive (FC 5673)	75
Loading and unloading tape cartridges	76
Loading a tape cartridge	76
Unloading a tape cartridge	76
Setting the write-protect switch.	77
Status lights (FC 5673).	77
Tape cartridges (FC 5673).	80
Resetting the tape drive	80
Managing DVD drives.	81
SATA Slimline DVD-ROM Drive (FC 5743)	81
SATA Slimline DVD-RAM Drive (FC 5762)	81
SATA Slimline DVD-RAM Drive (FC 5771)	82
Handling and storing the DVD media	83
Opening a DVD tray manually	83
DVD-RAM type II disc	83
Managing diskette drives.	85
External USB 1.44 MB diskette drive (FC 2591)	85
Managing disk devices	85
Managing removable disk drives	86
RDX USB Internal Dock (1103, 1123, EU03, and EU23) and RDX Removable Disk Drives (1106, 1107, EU01, EU08 and EU15).	86
RDX USB External Dock (1104 and EU04) and RDX Removable Disk Drives (1106, 1107, EU01, EU08, and EU15)	91
RDX SATA Internal Dock (EU07) and RDX Removable Disk Drives (1106, 1107, EU01, EU08, and EU15)	96
Managing communications devices	100
LAN-Attached Remote Asynchronous Node 16 (model 7036-P16)	100
7036-P16 description and overview	100
Installing 7036-P16 hardware	102
Installing Digi RealPort software for the 7036-P16 device	103
Configuring the 7036-P16 device and tty	105
Configuring the 7036-P16 into the network	107
Using diagnostic aids for the 7036-P16	110
Replacing and reconfiguring the 7036-P16	111
Field replacement units for the 7036-P16	114
Notices	117
Trademarks	118
Electronic emission notices	118
Class A Notices.	118
Class B Notices.	122
Terms and conditions.	125

Safety notices

Safety notices may be printed throughout this guide:

- **DANGER** notices call attention to a situation that is potentially lethal or extremely hazardous to people.
- **CAUTION** notices call attention to a situation that is potentially hazardous to people because of some existing condition.
- **Attention** notices call attention to the possibility of damage to a program, device, system, or data.

World Trade safety information

Several countries require the safety information contained in product publications to be presented in their national languages. If this requirement applies to your country, safety information documentation is included in the publications package (such as in printed documentation, on DVD, or as part of the product) shipped with the product. The documentation contains the safety information in your national language with references to the U.S. English source. Before using a U.S. English publication to install, operate, or service this product, you must first become familiar with the related safety information documentation. You should also refer to the safety information documentation any time you do not clearly understand any safety information in the U.S. English publications.

Replacement or additional copies of safety information documentation can be obtained by calling the IBM Hotline at 1-800-300-8751.

German safety information

Das Produkt ist nicht für den Einsatz an Bildschirmarbeitsplätzen im Sinne § 2 der Bildschirmarbeitsverordnung geeignet.

Laser safety information

IBM® servers can use I/O cards or features that are fiber-optic based and that utilize lasers or LEDs.

Laser compliance

IBM servers may be installed inside or outside of an IT equipment rack.

DANGER

When working on or around the system, observe the following precautions:

Electrical voltage and current from power, telephone, and communication cables are hazardous. To avoid a shock hazard:

- Connect power to this unit only with the IBM provided power cord. Do not use the IBM provided power cord for any other product.
- Do not open or service any power supply assembly.
- Do not connect or disconnect any cables or perform installation, maintenance, or reconfiguration of this product during an electrical storm.
- The product might be equipped with multiple power cords. To remove all hazardous voltages, disconnect all power cords.
- Connect all power cords to a properly wired and grounded electrical outlet. Ensure that the outlet supplies proper voltage and phase rotation according to the system rating plate.
- Connect any equipment that will be attached to this product to properly wired outlets.
- When possible, use one hand only to connect or disconnect signal cables.
- Never turn on any equipment when there is evidence of fire, water, or structural damage.
- Disconnect the attached power cords, telecommunications systems, networks, and modems before you open the device covers, unless instructed otherwise in the installation and configuration procedures.
- Connect and disconnect cables as described in the following procedures when installing, moving, or opening covers on this product or attached devices.

To Disconnect:

1. Turn off everything (unless instructed otherwise).
2. Remove the power cords from the outlets.
3. Remove the signal cables from the connectors.
4. Remove all cables from the devices.

To Connect:

1. Turn off everything (unless instructed otherwise).
2. Attach all cables to the devices.
3. Attach the signal cables to the connectors.
4. Attach the power cords to the outlets.
5. Turn on the devices.

(D005)

DANGER

Observe the following precautions when working on or around your IT rack system:

- Heavy equipment—personal injury or equipment damage might result if mishandled.
- Always lower the leveling pads on the rack cabinet.
- Always install stabilizer brackets on the rack cabinet.
- To avoid hazardous conditions due to uneven mechanical loading, always install the heaviest devices in the bottom of the rack cabinet. Always install servers and optional devices starting from the bottom of the rack cabinet.
- Rack-mounted devices are not to be used as shelves or work spaces. Do not place objects on top of rack-mounted devices.



- Each rack cabinet might have more than one power cord. Be sure to disconnect all power cords in the rack cabinet when directed to disconnect power during servicing.
- Connect all devices installed in a rack cabinet to power devices installed in the same rack cabinet. Do not plug a power cord from a device installed in one rack cabinet into a power device installed in a different rack cabinet.
- An electrical outlet that is not correctly wired could place hazardous voltage on the metal parts of the system or the devices that attach to the system. It is the responsibility of the customer to ensure that the outlet is correctly wired and grounded to prevent an electrical shock.

CAUTION

- Do not install a unit in a rack where the internal rack ambient temperatures will exceed the manufacturer's recommended ambient temperature for all your rack-mounted devices.
- Do not install a unit in a rack where the air flow is compromised. Ensure that air flow is not blocked or reduced on any side, front, or back of a unit used for air flow through the unit.
- Consideration should be given to the connection of the equipment to the supply circuit so that overloading of the circuits does not compromise the supply wiring or overcurrent protection. To provide the correct power connection to a rack, refer to the rating labels located on the equipment in the rack to determine the total power requirement of the supply circuit.
- *(For sliding drawers.)* Do not pull out or install any drawer or feature if the rack stabilizer brackets are not attached to the rack. Do not pull out more than one drawer at a time. The rack might become unstable if you pull out more than one drawer at a time.
- *(For fixed drawers.)* This drawer is a fixed drawer and must not be moved for servicing unless specified by the manufacturer. Attempting to move the drawer partially or completely out of the rack might cause the rack to become unstable or cause the drawer to fall out of the rack.

(R001)

CAUTION:

Removing components from the upper positions in the rack cabinet improves rack stability during relocation. Follow these general guidelines whenever you relocate a populated rack cabinet within a room or building:

- Reduce the weight of the rack cabinet by removing equipment starting at the top of the rack cabinet. When possible, restore the rack cabinet to the configuration of the rack cabinet as you received it. If this configuration is not known, you must observe the following precautions:
 - Remove all devices in the 32U position and above.
 - Ensure that the heaviest devices are installed in the bottom of the rack cabinet.
 - Ensure that there are no empty U-levels between devices installed in the rack cabinet below the 32U level.
- If the rack cabinet you are relocating is part of a suite of rack cabinets, detach the rack cabinet from the suite.
- Inspect the route that you plan to take to eliminate potential hazards.
- Verify that the route that you choose can support the weight of the loaded rack cabinet. Refer to the documentation that comes with your rack cabinet for the weight of a loaded rack cabinet.
- Verify that all door openings are at least 760 x 230 mm (30 x 80 in.).
- Ensure that all devices, shelves, drawers, doors, and cables are secure.
- Ensure that the four leveling pads are raised to their highest position.
- Ensure that there is no stabilizer bracket installed on the rack cabinet during movement.
- Do not use a ramp inclined at more than 10 degrees.
- When the rack cabinet is in the new location, complete the following steps:
 - Lower the four leveling pads.
 - Install stabilizer brackets on the rack cabinet.
 - If you removed any devices from the rack cabinet, repopulate the rack cabinet from the lowest position to the highest position.
- If a long-distance relocation is required, restore the rack cabinet to the configuration of the rack cabinet as you received it. Pack the rack cabinet in the original packaging material, or equivalent. Also lower the leveling pads to raise the casters off of the pallet and bolt the rack cabinet to the pallet.

(R002)

(L001)



(L002)



(L003)



or



All lasers are certified in the U.S. to conform to the requirements of DHHS 21 CFR Subchapter J for class 1 laser products. Outside the U.S., they are certified to be in compliance with IEC 60825 as a class 1 laser product. Consult the label on each part for laser certification numbers and approval information.

CAUTION:

This product might contain one or more of the following devices: CD-ROM drive, DVD-ROM drive, DVD-RAM drive, or laser module, which are Class 1 laser products. Note the following information:

- Do not remove the covers. Removing the covers of the laser product could result in exposure to hazardous laser radiation. There are no serviceable parts inside the device.
- Use of the controls or adjustments or performance of procedures other than those specified herein might result in hazardous radiation exposure.

(C026)

CAUTION:

Data processing environments can contain equipment transmitting on system links with laser modules that operate at greater than Class 1 power levels. For this reason, never look into the end of an optical fiber cable or open receptacle. (C027)

CAUTION:

This product contains a Class 1M laser. Do not view directly with optical instruments. (C028)

CAUTION:

Some laser products contain an embedded Class 3A or Class 3B laser diode. Note the following information: laser radiation when open. Do not stare into the beam, do not view directly with optical instruments, and avoid direct exposure to the beam. (C030)

CAUTION:

The battery contains lithium. To avoid possible explosion, do not burn or charge the battery.

Do Not:

- ___ Throw or immerse into water
- ___ Heat to more than 100°C (212°F)
- ___ Repair or disassemble

Exchange only with the IBM-approved part. Recycle or discard the battery as instructed by local regulations. In the United States, IBM has a process for the collection of this battery. For information, call 1-800-426-4333. Have the IBM part number for the battery unit available when you call. (C003)

Power and cabling information for NEBS (Network Equipment-Building System) GR-1089-CORE

The following comments apply to the IBM servers that have been designated as conforming to NEBS (Network Equipment-Building System) GR-1089-CORE:

The equipment is suitable for installation in the following:

- Network telecommunications facilities
- Locations where the NEC (National Electrical Code) applies

The intrabuilding ports of this equipment are suitable for connection to intrabuilding or unexposed wiring or cabling only. The intrabuilding ports of this equipment *must not* be metallically connected to the interfaces that connect to the OSP (outside plant) or its wiring. These interfaces are designed for use as intrabuilding interfaces only (Type 2 or Type 4 ports as described in GR-1089-CORE) and require isolation from the exposed OSP cabling. The addition of primary protectors is not sufficient protection to connect these interfaces metallically to OSP wiring.

Note: All Ethernet cables must be shielded and grounded at both ends.

The ac-powered system does not require the use of an external surge protection device (SPD).

The dc-powered system employs an isolated DC return (DC-I) design. The DC battery return terminal *shall not* be connected to the chassis or frame ground.

Managing devices for the 8202-E4B, 8202-E4C, 8202-E4D, 8205-E6B, 8205-E6C, or 8205-E6D

Learn about managing media and communications devices.

The topic contains reference information that information technology (IT) personnel and service representatives can use to learn about using and managing the following removable media devices and communication devices. You can also find specifications and installation notes for specific devices.

Note: The following features are the electromagnetic compatibility (EMC) Class B features. See the EMC Class B Notices in the Hardware Notices section.

- 36/72 GB Data72 4 mm Internal Tape Drive (5907)
- 80/160 GB DAT160 SAS Tape Drive (FC 5619)
- 80/160 GB DAT160 USB Tape Drive (FC EU16)
- 160/320 GB DAT320 SAS Tape Drive (FC 5661)
- 160/320 GB DAT320 USB Tape Drive (FC 5673)
- 1.5/3 TB LTO5 SAS Tape Drive (FC 5638)
- 2.5/6.25 TB LTO6 SAS Tape Drive (FC EU11)
- SATA Slimline DVD-ROM Drive (FC 5743)
- SATA Slimline DVD-RAM Drive (FC 5762)
- SATA Slimline DVD-RAM Drive (FC 5771)
- Internal RDX USB 2.0 Dock (1103)
- Internal RDX USB 3.0 Dock (EU03)
- RDX USB 2.0 External Dock (1104)
- RDX USB External Dock (EU04)
- RDX Removable Disk Drives (1106, 1107, EU01, EU08, and EU15)

Related concepts:

“Class B Notices” on page 122

Related information:



Adapters, Devices, and Cable Information for Multiple Bus Systems (SA38-0516)

Learn about earlier media and communications devices that are not covered in Managing devices, and that were available before October 2003.

Managing tape drives

Learn about using and managing removable media devices. Find specifications and installation notes for specific drives.

Tape drives

Learn general information about tape drives.

Select the appropriate information from this list:

- Tape drive overview
- Tape drive environment and use
- Tape handling and storage
- Environmental issues

- Tape drive cleaning
- SCSI hardware issues
- Microcode updates

Tape drive overview

Your tape drive must be installed in the cleanest possible environment. Additionally, tape drives require high quality, data grade tapes and cleaning on a regular basis. Media must also be stored and handled properly. Improper use, storage or handling of tape drives or media may void your warranty or service agreement. If a tape drive stops functioning due to a component failure during the tape drive warranty or maintenance time, the tape drive supplier will replace the tape drive unit. The tape drive supplier will replace any defective tape drive under the terms and conditions of the warranty or service agreement.

The tape drive is a streaming device used primarily for:

- Saving and restoring system data files
- Archiving important records
- Distributing operating system software upgrades

Note: The following information describes hardware features and functions. While the hardware supports them, the availability of these features and functions depends upon support from the operating system. For information about support for features and functions, see the documentation for your operating system.

Tape drive environment and use

Tape drives require specific maintenance and environmental conditions to operate well over time. Using high-quality, data-grade media, handling and storing this media correctly, operating the tape drive in a clean environment, and keeping the tape drive correctly cleaned can help you to avoid problems with your tape drive.

If a tape drive stops functioning due to a component failure during the tape drive warranty or maintenance time, the service provider will replace the tape drive unit. The service provider will replace any defective tape drive under the terms and conditions of its warranty or service agreement. It is the service provider's objective to work with you to identify the cause of any tape-drive problem and provide a solution.

Tape handling and storage

Most tape is supplied in a sealed cartridge so that the tape will remain clean. Opening the cartridge allows dirt and airborne particles to enter and then become a source of contamination. The cartridge should only be opened by the tape drive and not an operator. The tape also is held under proper tension inside the cartridge. If the cartridge is dropped, this tension will be relaxed.

Attention: Inserting a dropped cartridge into a tape drive can cause incorrect loading and result in a jam. This action will ruin the tape and can cause physical damage if the cartridge is not removed correctly.

When the tapes are stored, they must be replaced in their protective containers and stored on their end. The storage area must be clean, dry, at normal room temperature, and away from any magnetic fields. Improper use, storage, or handling of tape drives or media might void your warranty or service agreement.

Environmental issues

Tape drives are designed to operate in a clean environment. Problems can be caused by dirt, dust, fibers, and airborne particles. Airborne particles are the most difficult to address. When a tape is installed into the tape drive, the clearance between the heads and the tape is measured in microns. Particles can damage the tape or the head if they come in contact with either. Customers are responsible to provide a clean operating environment for the tape drive and system.

Tape drive cleaning

No matter how clean the environment, debris can build up on the heads of any tape drive. Every time tape motion occurs, some of the media surface comes off on the heads. Over time, this surface builds up and causes errors in reading and writing. Customers are responsible to clean the tape drive in accordance with the cleaning information that was provided with the tape drive.

Cleaning cartridges can be used a limited number of times. After a cleaning cartridge has been used to its maximum number of times, the cartridge is considered expired. When cartridges expire, they must be replaced. Never reuse an expired cleaning cartridge. Doing so allows previously removed dirt to be reintroduced to the tape drive. Place a mark on the cleaning cartridge after each use, to best determine when your cleaning cartridge has expired.

SCSI hardware issues

Note: If you are installing the auto-docking version of this device on your system, this section does not apply to your system. For information about the auto-docking feature, see your system documentation.

SCSI bus cables and terminators can affect tape drive performance. Use cables and terminators that are designed specifically to keep the SCSI bus as free of noise as possible. Generic cables or terminators can adversely affect the SCSI bus performance. If your service provider's analysis indicates a problem with inferior cables, it might be necessary for the customer to replace them.

Microcode updates

To make certain that the tape drives work their best, your system supplier might release changed microcode for the tape drives. When a microcode change is developed, your system supplier makes the change available to you through its service organization or by electronic delivery. You might be responsible for installing new microcode as it becomes available. However, microcode can be installed by your service provider or your system administrator. For more information, contact your authorized service provider.

Tape drive media

Learn about using the different types of tape drive media.

Attention: Your system supplier might support only the media that it sells. If the supplier's analysis indicates that the problem is caused by using inferior media, it is the customer's responsibility to replace the inferior media.

Select the appropriate information from this list:

- Types of cartridges
- Recommendations for data cartridge usage
- Prolonging head life
- Storage and shipping environments
- Tape cartridge storage
- Operating in harsh environments

- Ordering tape and data cartridges

Types of cartridges

Tape devices use the following media cartridges.

Data cartridge

Use the data cartridge to save or restore programs or data.

Test cartridge

Use the specially labeled test cartridge to run the AIX[®] system diagnostics (for information about running diagnostics, refer to your AIX documentation). Do not use the test cartridge to save or restore customer programs or data.

Cleaning cartridge

Use the specially labeled cleaning cartridge to clean the device.

Attention: Use of other than the IBM specified cleaning cartridge can damage your device and might void your warranty.

To order additional cartridges, refer to Ordering tape cartridges.

Recommendations for data cartridge usage

The following list describes recommended guidelines that will help to protect your data and prolong the life of your tape cartridges and the device:

- Use only the tape cartridge specified for your type of tape device.
- Remove the tape cartridge from the drive when the drive is not in use.
- Back up and then discard any tape cartridge that repeatedly produces error messages (the error information is in the System Error Log).
- On the data cartridge, do not open the door that covers the tape. The door protects the tape from dirt, dust, and damage.
- Do not touch the tape. Any substance transferred to the tape by touching could cause loss of data.
- To avoid problems with loading and unloading, use only one label on a cartridge. Multiple or poorly placed labels can clog the drive load mechanism.
- Do not use poor-quality tape cartridges. They can cause excessive read or write errors, and they might damage the tape drive.
- Discard any tape cartridges that are dropped, because the impact might damage the tape's internal mechanism.
- Make sure the environment is kept clean and constant. Do not operate in a dusty environment and always maintain a constant environment. A consistent storage and operating environment reduces media exposure to climatic stress.
- Use only the recommended cleaning cartridge to clean the tape drive. Use of other than recommended cleaning cartridges can damage your drive and might void the warranty.
- Printers and copiers can produce paper dust and toner dust. Locate the tape unit away from these items. High traffic areas near hallways and doors can also produce excess dust and dirt.
- Record all important information on the tape label. Information, such as the model and number of the system or tape drive, the date, the density, any error statistics, and include a log number. Also note the operating environment and compression mode.

Prolonging head life

New technology found in the tape device is read and write compatible with newer tape cartridges. Due to media characteristics, extended use of older tape cartridges might increase head wear on the drive. An

indication of this head wear is an increase in soft (recoverable) errors. Using newer tape cartridges may have enhanced characteristics that can reduce drive head wear and maximize the overall advantages of the tape device.

Storage and shipping environments

Before using a tape cartridge, let it acclimatize to the operating environment by placing the cartridge in the operating environment for as long as it has been away from the environment or for 24 hours, whichever is less. Acclimatization is necessary for any data cartridge exposed to an environmental change in humidity or to temperature changes of 11°C (20°F) or more. To determine the appropriate operating environment, see Tape drive environment and use.

Retrieval of archived data can be performed on a tape unit that is clean and fully operational. Try to make the recovery environment the same as the operating environment. Allow tapes at least 24 hours to acclimatize to the environment of the tape unit.

The recommended environment for storage and shipment of cartridges is shown in Table 1.

Table 1. Recommended environment for data cartridges

Environmental Factor	Storage	Shipping
Temperature	5°C - 32°C (41°F - 90°F)	-40 - 52°C (-40 - 125°F)
Relative Humidity (noncondensing)	20% - 60%	5% - 80%
Maximum Wet Bulb	26°C (79°F)	26°C (79°F)

Tape cartridge storage

Tape drives record data using densities similar to hard disk drives. Because most computer systems are not located in a dust-free, climate-controlled environment, you must exercise special care when dealing with tape cartridges and tape drives. They must be treated as a valuable asset used to protect your business data.

Use the following guidelines for storing your tape cartridges:

- Keep temperature and humidity constant at the levels listed in Table 1.
- Always store tape cartridges in their protective cases. The storage case helps prevent damage from dust and physical misuse. When the tape cartridges are not in use or being stored, keep them in their storage cases and stand on edge in a designated storage location. Do not stack cartridges on the flat side or stack other items on top of the tape cartridges. Handle your tape cartridges with care to reduce archival problems.
- Keep protective cases for tape cartridges closed except when inserting or removing a cartridge. Contamination can build up and be transferred to the tape cartridge if the protective case is left open.
- Exercise stored tapes at least once every 12 months. Run the tape from Beginning of Data (BOD) to End of Data (EOD) and back to BOD at normal operating speeds. Exercise tapes stored in a warmer environment more frequently.
- Sunlight can damage the tape and the cartridge shell. Store tape cartridges out of the direct sunlight.

Attention: Operation outside of the recommended environment can result in possible loss of data or failure of the drive.

Operating in harsh environments

The device is suited to streaming operations, as opposed to multiple stop-and-start, random-search tape operations. When the tape is used for frequent stop-and-start operations, it is beneficial to still have as much streaming movement as possible. This can be accomplished by ensuring that any save or restore operation is the only active operation being performed.

Do not use any tape for archival purposes if it has been used outside of the ranges specified in Table 1 on page 5 for an extended period of time. The magnetic and physical strength of the tape will have deteriorated as a result of its exposure to the environment. Do not store important data on such a tape; transfer the data to a newer tape for reliable archiving.

Ordering tape and data cartridges

All tape cartridges are not alike. The tape composition and length, and the construction of the cartridge itself can all affect the quality and capacity of the recording and the performance of your tape drive. A poor quality tape cartridge might appear to work adequately in your system, yet it can leave contamination in the tape path or impede the speed of the recording.

The length and composition of the tape, and the size, shape, and construction of the cartridge shell must all be considered when selecting the tape cartridge to be used with your system. IBM supports using only data and cleaning cartridges supplied by IBM. Use only data-grade tape media for backup and data processing.

To order cartridges in the United States and Canada, call 1-888-IBM-MEDIA, or go to [Storage media](#)  .

To order cartridges in other locations, contact your local provider of IBM storage products.

Table 2. Recommended test, cleaning, and 4mm data cartridges for the specific type of tape drive

Tape drive	Part number	Type of cartridge	Capacity
DDS3	59H3466	Test Cartridge	11.5m
	21F8763	Cleaning Cartridge	50 cleanings
	59H3465	Data Cartridge	12 GB
DDS4	59H4457	Test Cartridge	11.5m
	21F8763	Cleaning Cartridge	50 cleanings
	59H4458	Data Cartridge	20 GB
DAT72	59H4457	Test Cartridge	11.5m
	21F8763	Cleaning Cartridge	50 cleanings
	18P7912	Data Cartridge	36 GB
DAT160	23R5636	Test Cartridge	155m
	23R5638	Cleaning Cartridge	25 cleanings (minimum)
	23R5635	Data Cartridge	80 GB
DAT320	46C1938	Test Cartridge	153m
	46C1937	Cleaning Cartridge	27 cleanings (minimum)
			50 cleanings (average)
			70 cleaning (maximum)
46C1936	Data Cartridge	160 GB	

Table 3. Recommended 8-mm data cartridges

Part number	Type of cartridge	Length
35L1044	20 GB AME with SmartClean Data Cartridge	75 m (246 ft)
09L5323	40 GB AME with SmartClean Data Cartridge	150 m (492 ft)
18P6484	60 GB AME with SmartClean Data Cartridge	225 m (738 ft)
35L1409	Cleaning Cartridge	

Table 4. Recommended VXA X-type data cartridges

Part number	Type of cartridge	Length
24R2137	80/160 GB X23 VXA Data Cartridge	230 m (754 ft)
24R2136	40/80 GB X10* VXA Data Cartridge	124 m (406 ft)
24R2134	20/40 GB X6* VXA Data Cartridge	62 m (203 ft)
24R2135	VXA X6* Test Cartridge	62 m (203 ft)
24R2138	VXA 20 X Cleaning Cartridge	
Note: *X type media requires a minimum microcode level of 2105.		

Table 5. Recommended VXA V Type data cartridges

Part number	Type of cartridge	Length
19P4876	80/160 GB V23 VXA Data Cartridge	230 m (754 ft)
24R2136	40/80 GB V10 VXA Data Cartridge	124 m (406 ft)
19P4878	20/40 GB V6 VXA Data Cartridge	62 m (203 ft)
19P4879	VXA V6 Test Cartridge	62 m (203 ft)
19P4880	VXA 20 V Cleaning Cartridge	
Note: V cartridges are the original VXA cartridge.		

Table 6. LTO Ultrium data cartridges

Part number	Type of cartridge	Length
08L9120	100/200GB LTO Ultrium 1 Data Cartridge	610 m (2000 ft)
08L9870	200/400GB LTO Ultrium 2 Data Cartridge	610 m (2000 ft)
24R1922	LTO-3 Data Cartridge (400GB/800GB)	
96P1203	LTO-3 Worm Data Cartridge	
95P4436	LTO-4 Data Cartridge (800GB/1.6TB)	
95P4450	LTO-4 Worm Data Cartridge	
45E1129	LTO-4 Test Cartridge	
24R0395	LTO Gen-2 Test Cartridge	610 m (2000 ft)
35L2086	Universal Cleaning Cartridge	
46X1290	LTO-5 Data Cartridge(1.5 TB / 3.0 TB) Write/Read	
46C2009	LTO-5 Test Cartridge(1.5 TB / 3.0 TB) Write/Read	
46X1292	LTO-5 Worm Data Cartridge Write 1x/Read many	

Table 7. RDX data cartridges

Feature code	IBM part number	Type of cartridge
1106	46C5375	160 GB RDX Removable Hard Disk Cartridge
EU08	46C5377	320 GB RDX Removable Hard Disk Cartridge
1107	46C5379	500 GB RDX Removable Hard Disk Cartridge
EU01	46C2335	1 TB RDX Removable Hard Disk Cartridge
EU15	46C2831	1.5 TB RDX Removable Hard Disk Cartridge

Preparing the tape drive for installation

Find what you need to know before you install a SCSI tape drive.

Handling recommendations

Attention: Be sure to read these instructions before you remove the device from its anti-static bag or any time you handle it.

For optimum performance, always follow these recommendations:

- Handle the drive carefully and by its external metal chassis. Keep your hands away from the printed circuit boards, components, and printed circuit (flex) cables.
- If possible, work on a cushioned surface, and do not drop the device onto the work surface.
- If you move the device to an environment that is colder or warmer than its previous environment, keep the drive in its package and allow the package to reach the current room temperature. This action prevents potential data loss or damage to the device. Allow one hour of acclimatization for each 10 degrees C (18 degrees F) difference between the ship or storage temperature and the room temperature.

Note: If you are installing the auto-docking version of this device on your system, the remainder of this information does not apply to your system. For information about the auto-docking feature, see your system documentation.

Planning your serial-attached SCSI (SAS) device layout

SAS devices do not require you to set a SCSI address before connecting to a SAS bus.

Configuring the tape drive

To configure the drive after installation, boot your system unit. Device drivers are provided in the operating systems that support the drive. Your operating system recognizes the drive and automatically updates your system unit configuration.

Updating microcode levels

Media devices contain microcode that you can update. For instructions about how to obtain and install the latest microcode levels for your device, go to Fix Central.

1.5/3.0 TB Ultrium 5 SAS tape drive (FC 5638)

Learn about the features of this media device.

Table 8. 1.5/3.0 TB Ultrium 5 SAS tape drive features

Feature	Description
Description	<p>The Ultrium 5 serial attached SCSI (SAS) tape drive is a half-high tape drive designed for Open Systems backup and restore applications. These files can include multimedia, imaging, transaction processing, large databases, and other storage-intensive applications. It is the fourth generation in the Ultrium series of products, and is available with a Serial Attached SCSI interface (SAS). The tape drive is an LTO Ultrium 5 standard interchange device. The drive will read tapes written by other Ultrium 5 drives, and will write to tapes readable by other Ultrium 5 drives. For an illustration of the drive, see Front view of tape drive.</p> <p>Characteristics:</p> <ul style="list-style-type: none"> • Single port 6 Gbps Serial Attached Small Computer Systems Interface (SAS) • FRU part number is 46C2007. For media part numbers, see “Tape cartridges (FC 5638)” on page 21. • Native storage capacity of 1500 GB per cartridge (3000 GB at 2:1 compression) • Custom card identification number (CCIN) number is 63A0 • Data transfer rate: 140 MB per second native mode, 240 MB per second at 2:1 compression • Burst data transfer rate of 600 MB per second • 256 MB read-and-write cache • Support for encryption on Ultrium 5 tape cartridges • Single Character Display (SCD) operator panel • Ready and Fault status lights • Maintenance Mode functions • Downward read and write compatibility with earlier LTO-type data cartridges. • Bootable device, depending on the host system configuration • Operation: Streaming • Half height form factor • Can be used as an bootable device, depending on the host system configuration.
Tools	<p>The following tools and documentation are needed to complete the installation:</p> <ul style="list-style-type: none"> • A flat-blade screwdriver (if this device is not an auto-docking feature on your system) • Your system unit documentation, including any service documentation • Your operating system documentation <p>Contact the place of purchase if an item is missing or damaged.</p> <p>Note: If you are installing the auto-docking version of this device on your system, see your system documentation for information about the auto-docking feature.</p>
Media	<p>The drive will read and write on Ultrium 5 and Ultrium 4 cartridges, and read Ultrium 3 cartridges. The drive will not read or write on Ultrium 2 and Ultrium 1 cartridges.</p> <p>Each Ultrium 5 tape cartridge can store up to 1.5 TB of uncompressed data, or up to 3.0 TB of compressed data.</p> <p>Note: The actual capacity varies depending on the application, the type of data, and the tape cartridge. When data compression is activated, 1.5 TB is typical and 3.0 TB is possible. The default setting of data compression is controlled by the host system. The user and the application software can control the activation or deactivation of the data compression setting. The drive can optimally achieve a 2:1 compression ratio.</p>

Table 8. 1.5/3.0 TB Ultrium 5 SAS tape drive features (continued)

Feature	Description
Related information	<p>Your package contains the following items:</p> <ul style="list-style-type: none"> • The tape drive • Media kit containing: <ul style="list-style-type: none"> – One cleaning cartridge – One test tape • Specific hardware for attaching the drive to your specific system, as detailed on the parts listing provided with your drive.

Eject button functions on the tape drive (FC 5638)

You might need to eject a tape, reset the drive, or place the drive in maintenance mode. Use the information in this topic to perform these tasks.

The drive has an eject button that enables you to perform the functions shown in the following table. The eject button is illustrated in Figure 1 on page 11.

Table 9. Eject button functions on the tape drive

Function	How to start the function
Reset the drive	<p>Press and hold the Unload Button until the drive begins the reset procedure (status light will be amber).</p> <p>Note: If a tape cartridge is loaded in the drive, the drive will unload the tape. Repeat the reset procedure after the tape is unloaded. The drive saves a dump of the current drive state, and then reboots to allow communication. Do not cycle power as this will erase the contents of the dump.</p>
Rewind the tape into the cartridge and eject the cartridge from the tape drive	<p>Press the Unload Button once. The status light flashes green while the drive is rewinding and unloading.</p> <p>Note: During a rewind and eject operation, the drive does not accept SCSI commands from the server.</p>
Place the tape drive in maintenance mode	<p>Ensure that the drive is unloaded. Then, press and hold the Unload Button for 6 seconds. The drive is in maintenance mode when the Status Light becomes solid amber and 0 appears in the SCD.</p> <p>Note:</p> <ol style="list-style-type: none"> 1. While in maintenance mode, the drive does not accept SCSI commands. 2. If you attempt to enter maintenance mode with a cartridge in the drive, the drive will rewind and eject the cartridge. Remove the cartridge and repeat the steps for entering maintenance mode.
Scroll through the maintenance functions	<p>While in maintenance mode, press the Unload Button once per second to increment the display characters by one. When you reach the character of the diagnostic or maintenance function that you want (see Table 14 on page 24), press and hold the Unload Button for three seconds.</p>
Exit maintenance mode	<p>Press the Unload Button once per second until 0 is displayed. Then press and hold the Unload Button for three seconds. Maintenance mode is exited when the Status Light becomes solid green and the SCD becomes blank.</p>

Table 9. Eject button functions on the tape drive (continued)

Function	How to start the function
Force a drive dump (part of the maintenance mode)	<p>Attention: If the drive detects a permanent error and displays an error code, it automatically forces a drive dump (also known as a save of the firmware trace). If you force a drive dump, the existing dump will be overwritten and data will be lost. After you force a drive dump, do not turn off the power to the drive or you might lose the dump data.</p> <p>Choose one of the following procedures:</p> <ul style="list-style-type: none"> • If the drive is in maintenance mode (status light is solid amber), see Table 14 on page 24 to view the available maintenance functions. • If the drive is in operating mode (status light is solid or flashing green), press and hold the Unload Button for 10 seconds. <p>If captured dump data exists, the drive places it into a dump area.</p>

Status lights (FC 5638)

You might need to read the status lights on your tape drive to determine the operating status of the drive. Use the information in this topic to perform this task.

Two status light-emitting diode (LED) lights and their ISO symbols appear on the drive as follows:

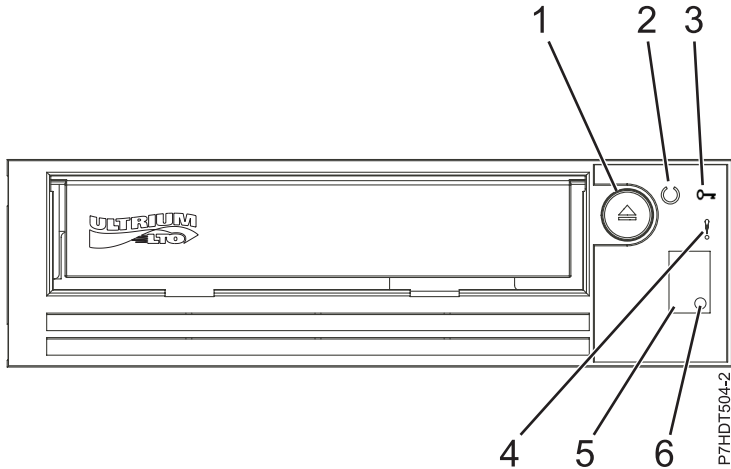

Figure 1. Front view of a half-high LTO tape drive

Index number	Description
1	Eject button
2	Ready LED
3	Encrypt LED
4	Fault LED
5	Single-character display (SCD)
6	SCD light

Note:

1. The required preventative maintenance cleaning frequency is approximately 100 tape motion hours or when the drive indicates cleaning is required. Tape motion hours are defined as the time the tape drive is moving tape.
2. When a fault occurs, the drive causes the AIX operating system to log an information error (TAPE_ERR6) in the AIX log, indicating that the tape drive needs to be cleaned.
3. Use only IBM media. IBM only supports the use of IBM media and IBM cleaning cartridges.
4. When the tape drive indicates that the drive needs to be cleaned, it is the customer's responsibility to clean the tape drive with the recommended cleaning cartridge.

Table 10. Status light considerations

Mode	SCD	Ready LED (green)	Fault LED (amber)
Operational	Blank	On	Off
Activity (tape movement) in Operational Mode	Blank	Flashing	Off
Maintenance	Solid character	Off	On
Executing Maintenance Selection	Flashing character	Off	On
Error Condition	Solid character	Off	Flashing
Power-On / Reset Initialization	random segments	Off	On

The following table lists the conditions of the Status Lights and Single-character Display (SCD) and provides an explanation of what each condition means.

Table 11. Meaning of Status Lights and Single-character Display (SCD)

If the green Ready Status Light is...	and the amber Fault Status Light is...	and the SCD is...	and the SCD Dot is...	Meaning
Off	Off	Off	Off	The drive has no power or is powered off.
Green/Solid	Off	Off	Off	The drive is powered on and in an idle state.
Flashing Green (once per second)	Off	Off	Off	The drive is reading from the tape, writing to the tape, rewinding the tape, locating data on the tape, loading the tape, or unloading the tape.
Flashing Green (once per second)	Off	Off	Off	If the drive contains a cartridge during the power-on cycle, the drive completes POST and slowly rewinds the tape (the process may take up to ten minutes). The light stops blinking and becomes solid when the drive completes the recovery and ejects the cartridge.
Off	Amber/Solid	Displaying an error code or Maintenance Mode Function	On/Off	The drive is displaying error code(s) from the error code log on the SCD. For information on error code and messages, see Table 12 on page 13.

Table 11. Meaning of Status Lights and Single-character Display (SCD) (continued)

If the green Ready Status Light is...	and the amber Fault Status Light is...	and the SCD is...	and the SCD Dot is...	Meaning
Off/On	Off/On	Displaying random segments / Blank / displaying random segments / displaying 8 / Blank	Off	<p>During power on, or a drive reset, the drive front panel will display drive progress as follows:</p> <ol style="list-style-type: none"> 1. SCD will display random segments (no LEDs ON). 2. SCD will go blank (LEDs - Green ON, Amber OFF) 3. SCD will display random segments (LEDs - Green OFF, Amber ON) 4. SCD will display 8 (LEDs - Green OFF, Amber ON) 5. SCD will go blank (LEDs - Green ON, Amber OFF) after a successful power on or reset. <p>If an error is detected during the power on or reset, the tape drive posts an error code to the SCD.</p>
Off	Amber/Solid	Displaying 0	Off/On	The drive is entering or exiting from maintenance mode.
Off	Amber/Solid	Flashing selected function	Off/On	The drive is executing the selected function while in maintenance mode.
Off	Flashing Amber (once per second)	Displaying error code	Off	An error occurred and the drive or media may require service, or it may require cleaning.
Off	Flashing Amber	Displaying C	Off	The drive needs cleaning.
Off	Flashing Amber	Displaying 2	Off	The drive is updating firmware.
Off	Flashing Amber (twice per second)	Off	Off	The drive detected an error and is performing a firmware recovery. It will reset automatically.
Off	Amber/Solid	Displaying C	Off	The drive is requesting a cartridge to be loaded.
Off	Flashing Amber (twice per second)	Off	On	There is a drive dump in flash memory.

Table 12. LTO-5 Tape Drive Error Codes

Error Code	Cause and Action
0	<p>No error occurred and no action is required. This code displays when diagnostics have finished running and no error occurred.</p> <p>Note: The Single-character Display is blank during normal operation of the tape drive.</p>

Table 12. LTO-5 Tape Drive Error Codes (continued)

Error Code	Cause and Action
1	<p>Temperature problem. The tape drive detected that the recommended operating temperature was exceeded. Perform one or more of the following actions:</p> <ul style="list-style-type: none"> • Ensure that the cooling fan is rotating and is quiet. If not, refer to your enclosure documentation. • Remove any blockage that prevents air from flowing freely through the tape drive. • Ensure that the operating temperature and airflow is within the specified range. <p>Clear the error code by power cycling the tape drive or placing the drive in Maintenance Mode. If the operating temperature and airflow are within the specified range, and the problem persists, replace the drive.</p>
2	<p>Power problem. The tape drive detected that the externally supplied power is outside the specified voltage limits (the tape drive is not operating). Perform the following action:</p> <ul style="list-style-type: none"> • Ensure that the power connector is properly seated. • Ensure that the proper dc voltages are being applied within the tolerances allowed. • If the proper voltages are not being applied, service the power supply. • If the proper voltages are being applied, power off/on the tape drive to see if the problem repeats. • Replace the tape drive if the problem persists. <p>The error code clears when you place the tape drive in maintenance mode.</p>
3	<p>Firmware problem. The tape drive determined that a firmware error occurred. Perform the following action:</p> <ul style="list-style-type: none"> • Collect a drive dump from one of the following: <ul style="list-style-type: none"> Note: Do not force a new dump; the tape drive has already created one. – Server’s host interface by using a device driver utility or system tool (for instructions about reading a drive dump from tape, visit the Web at http://www.ibm.com/storage/lto) – Ultrium Tape Drive (copy and read a drive dump) • Power the tape drive off and on, then retry the operation that produced the error. • If the problem persists, download new firmware and retry the operation. • If the problem persists, send the drive dump that you collected to your IBM Support Center. <p>The error code clears when you place the tape drive in maintenance mode.</p>

Table 12. LTO-5 Tape Drive Error Codes (continued)

Error Code	Cause and Action
4	<p>Firmware or hardware problem. The tape drive determined that a firmware or tape drive hardware failure occurred. Perform the following action:</p> <ul style="list-style-type: none"> • Collect a drive dump from one of the following: <ul style="list-style-type: none"> Note: Do not force a new dump; the tape drive has already created one. – Server’s host interface by using a device driver utility or system tool (for instructions about reading a drive dump from tape, visit the Web at http://www.ibm.com/storage/lto) – Ultrium Tape Drive (copy and read a drive dump) • Power the tape drive off and on, then retry the operation that produced the error. The error code clears when you place the tape drive in maintenance mode. • If the problem persists, download new firmware and retry the operation; if new firmware is not available, replace the drive.
5	<p>Tape drive hardware problem. The drive determined that a tape path or read/write error occurred. To prevent damage to the drive or tape, the tape drive will not allow you to insert a cartridge if the current cartridge was successfully ejected. The error code may clear when you cycle power to the tape drive or place it in maintenance mode. If the problem persists, replace the drive.</p> <p>Note: Copy the drive dump to flash memory before returning the drive.</p>

Table 12. LTO-5 Tape Drive Error Codes (continued)

Error Code	Cause and Action
6	<p>Tape drive or media error. The tape drive determined that an error occurred, but it cannot isolate the error to faulty hardware or to the tape cartridge. Ensure the tape cartridge is the correct media type:</p> <ul style="list-style-type: none"> • Ultrium -1 and Ultrium -2 tape cartridges are not supported in Ultrium-5 tape drives. • Drive will not accept an expired Cleaning Cartridge. • Drive will not accept a WORM cartridge when running diagnostic tests in Maintenance Mode. • Drive will not write over existing datasets on a WORM cartridge. Ensure you are appending datasets on WORM media rather than attempting to write over existing datasets. <p>If the tape cartridge is the correct media type, perform the following action:</p> <p>For Problems with Writing Data:</p> <p>If the problem occurred while the tape drive was writing data to the tape, retry the operation with a different cartridge:</p> <ul style="list-style-type: none"> • If the operation succeeds, the original cartridge was defective. Copy data from the defective cartridge and discard it. • If the operation fails and another tape drive is available, insert the cartridge into the other unit and retry the operation. <ul style="list-style-type: none"> – If the operation fails, discard the defective cartridge. – If the operation succeeds, insert a scratch data cartridge into the first unit and run the drive diagnostics. <ul style="list-style-type: none"> - If the diagnostics fail, replace the tape drive. - If the diagnostics succeed, the error was temporary. • If the operation fails and another tape drive is not available, insert a scratch data cartridge into the unit and run the drive diagnostics. <ul style="list-style-type: none"> – If the diagnostics fail, replace the tape drive. – If the diagnostics succeed, discard the cartridge. <p>If the problem occurs with multiple tape cartridges, run the drive diagnostics.</p> <p>The error code clears when you remove the tape cartridge or place the tape drive in maintenance mode.</p>

Table 12. LTO-5 Tape Drive Error Codes (continued)

Error Code	Cause and Action
	<p>For Problems with Reading Data:</p> <p>If the problem occurred while the tape drive was reading data from the tape, perform one of the following procedures:</p> <ul style="list-style-type: none"> • If another tape drive is available, insert the cartridge into the other unit and retry the operation. <ul style="list-style-type: none"> – If the operation fails, discard the defective cartridge. – If the operation succeeds, insert a scratch data cartridge into the first unit and run the drive diagnostics. <ul style="list-style-type: none"> - If the diagnostics fail, replace the tape drive. - If the diagnostics succeed, the error was temporary. • If another tape drive is not available, insert a scratch data cartridge into the unit and run the drive diagnostics. <ul style="list-style-type: none"> – If the diagnostics fail, replace the tape drive. – If the diagnostics succeed, discard the cartridge. <p>If the problem occurs with multiple tape cartridges, run the drive diagnostics.</p>

Table 12. LTO-5 Tape Drive Error Codes (continued)

Error Code	Cause and Action
7	<p>Media error. The tape drive determined an error occurred because of a faulty tape cartridge or an invalid tape cartridge. Ensure the tape cartridge is the correct media type:</p> <ul style="list-style-type: none"> • Ultrium -1 and Ultrium -2 tape cartridges are not supported in Ultrium-5 tape drives. • Drive will not accept an expired Cleaning Cartridge. • Drive will not accept a WORM cartridge when running diagnostic tests in Maintenance Mode. • Drive will not accept an FMR tape. • Drive will not write over existing datasets on a WORM cartridge. Ensure you are appending datasets on WORM media rather than attempting to write over existing datasets. <p>If the tape cartridge is the correct media type, try another tape cartridge. If the problem occurs with multiple tape cartridges, use the following procedure:</p> <p>If possible, run the tape cartridge in a different tape drive. If the operation in the other unit fails and 6 or 7 displays, replace the media. If the operation succeeds, run Function Code E: Test Cartridge and Media.</p> <p>Attention: When you run the Test Cartridge & Media diagnostic, data on the suspect tape is overwritten. Use only a scratch data cartridge to run the test.</p> <ul style="list-style-type: none"> • If the diagnostic fails, replace the media. • If the diagnostic succeeds, clean the drive head and run Function Code 1: Run Drive Diagnostics. <ul style="list-style-type: none"> – If the drive diagnostic fails, replace the drive. – If the drive diagnostic succeeds, perform the operation that produced the initial media error. <p>The error code clears when you remove the tape cartridge or place the tape drive in maintenance mode.</p>
8	<p>Interface problem. The tape drive determined that a failure occurred in the tape drive's hardware or in the host bus.</p>
9	<p>Tape drive or RS-422 error. The tape drive determined that a failure occurred in the tape drive's hardware or in the RS-422 connection. Refer to the Library procedures to isolate the problem to the drive. The error code clears when you place the tape drive in maintenance mode.</p>

Table 12. LTO-5 Tape Drive Error Codes (continued)

Error Code	Cause and Action
A	<p>Degraded operation. The tape drive determined that a problem occurred which degraded the operation of the tape drive, but it did not restrict continued use. If the problem persists, determine whether the problem is with the drive or the media.</p> <p>Note: The drive is usable, though the Single-character Display continues to indicate an error and the Status LED flashes amber. The error code may clear when you cycle power to the tape drive or place it in maintenance mode. To determine if the problem is with the drive hardware, or the tape media, perform the following procedures:</p> <ol style="list-style-type: none"> 1. If possible, run the tape cartridge in a different drive. If the operation in the other drive fails and 6 or 7 displays, replace the media. If the operation succeeds, run the Function Code E: Test cartridge and media diagnostic. 2. If the Test cartridge and media diagnostic fails, replace the media. If it runs successfully, clean the failing drive and run the Function Code 1: drive diagnostics. Once you begin this test, the diagnostic begins the loop sequence. Time the first loop by pressing the Unload button once to stop the diagnostic after the completion of the first loop, then record the time it takes for the test to complete. Compare the recorded time with the Approximate Run Time. If the test runs successfully but the execution time is significantly longer than the Approximate Run Time, run Function Code F: Write performance test. If the Write performance test fails, replace the media and exit maintenance mode. If the drive diagnostics run successfully, perform the operation that produced the initial drive error. 3. If the problem persists replace the drive. <p>If it is not possible to run the tape cartridge in a different drive, perform the following procedures:</p> <ol style="list-style-type: none"> 1. Clean the failing drive and run the drive diagnostics. Once you begin this test, the diagnostic begins the loop sequence. Time the first loop by pressing the Unload button once to stop the diagnostic after the completion of the first loop, then record the time it takes for the test to complete. Compare the recorded time with the Approximate Run Time. If the test runs successfully but the execution time is significantly longer than the Approximate Run Time, run Function Code F: Write performance test. If the write performance test fails, replace the media and exit maintenance mode. If the drive diagnostics run successfully, run the Function Code E: Test cartridge and media diagnostic. 2. If the test cartridge & media diagnostic fails, replace the media. If it runs successfully, perform the operation that produced the initial drive error. 3. If the problem persists replace the drive.

Table 12. LTO-5 Tape Drive Error Codes (continued)

Error Code	Cause and Action
C	<p>The tape drive needs to be cleaned. Clean the tape drive.</p> <p>The error code clears when you clean the tape drive or place it in maintenance mode.</p>
d	<p>Fiber AL_PA conflict. NOT SUPPORTED ON THIS DRIVE.</p>
e	<p>Encryption Error. Displayed when the drive detects an error associated with a encryption operation. If the problem occurred while the tape drive was writing data to, or reading data from, tape:</p> <ol style="list-style-type: none"> 1. Check the host application to ensure the host application is providing the correct encryption key. <ul style="list-style-type: none"> • Refer to the IBM Tape Device Drivers Encryption Support documentation and the IBM LTO Ultrium Tape Drive SCSI Reference documentation for the Sense Data returned for an encryption operation. • Retry the encryption operation after the host application problems have been resolved. 2. Check the operation of the tape drive by resetting the drive and running POST. <ul style="list-style-type: none"> • Refer to the error code displayed on the SCD if the drive reset and POST fails. • Retry the encryption operation if the drive reset and POST complete without errors. 3. Check the media. <ul style="list-style-type: none"> • Ensure the correct media is being used. Data encryption is supported with LTO Ultrium 5 Data Cartridges only. • Retry the encryption operation with the tape cartridge in another encryption enabled drive. Replace the media if the problem repeats with the same tape cartridge in multiple drives. <p>If the problem occurred while the tape drive was running POST or diagnostics, replace the drive.</p> <p>The error code clears with the first attempted write/read after the encryption key is changed, or when the drive is placed in maintenance mode.</p>
E	<p>Fiber Port offline. NOT SUPPORTED ON THIS DRIVE.</p>
F	<p>Fiber Channel Error. NOT SUPPORTED ON THIS DRIVE.</p>
J	<p>Incompatible Media. Media that the drive cannot execute commands on has been loaded.</p>

Table 12. LTO-5 Tape Drive Error Codes (continued)

Error Code	Cause and Action
P	Write operation to a write protected cartridge has been attempted (this includes any attempt to overwrite a WORM protected tape). Ensure the tape cartridge is the correct media type. Writes to Ultrium-2 tape cartridges are not supported in Ultrium-5 tape drives. If the tape cartridge is the correct media type, check the write-protect switch on the cartridge. The drive will not write to a write-protected cartridge. The error code clears when you remove the tape cartridge or place the tape drive in maintenance mode.
Bouncing o	Broken or excessive slack tape. Drive has encountered a condition where it cannot unload the tape or determine that the tape is in the path of the head. Manual intervention required.
Figure 8	Mid Tape Recovery. Drive is recovering from a power cycle with a tape in the drive. The 'figure 8' is broken up with a countdown indicating progress in ten's percentage to completion: 9, 8, 7, 6, 5, 4, 3, 2, 1.

Tape cartridges (FC 5638)

Learn about the types of tape cartridges that are available for this drive.

Available tape cartridges

Table 13. LTO Ultrium data cartridges

Part number	Type of cartridge
46C2009	Test Cartridge Gen 5
35L2086	Universal LTO Cleaning Cartridge
46X1290	LTO-5 Data Cartridge(1.5 TB / 3.0 TB), Write/Read
46C2009	LTO-5 Test Cartridge(1.5 TB / 3.0 TB), Write/Read (not customer orderable)
46X1292	LTO-5 Worm Data Cartridge, Write 1x/Read many

Attention: Do not attempt to bulk erase an LTO data cartridge for reuse. Bulk eraser devices cannot properly erase an LTO data cartridge and cause permanent damage to the cartridge.

Setting the write-protect switch

You might need to set the write-protect switch on the media. Use the information in this topic to perform this task.

The position of the write-protect switch on the tape cartridge determines when you can write to the tape as shown in the following figure. Before loading cartridges into magazines, you should set the write-protect switch of each cartridge to enable or disable data recording.

- To enable data recording, slide the write-protect to the left so that the write-protect window is open.
- To disable data recording, slide the write-protect switch to the right so that the locked icon appears on the switch.

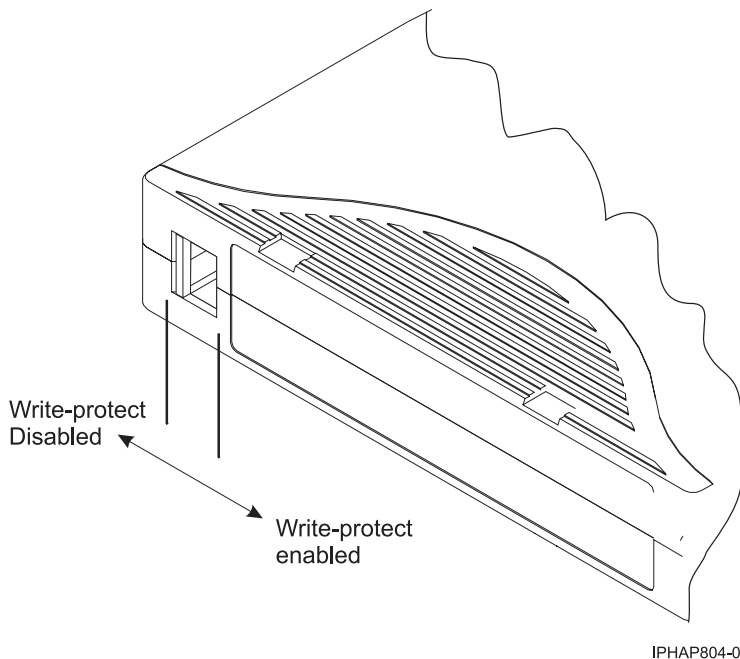

Cleaning the tape drive (FC 5638)

You will need to clean your tape drive. Use the procedure in this topic to perform this task.

Clean the LTO-5 tape drive whenever C displays on the Single-character Display and the Status Light is flashing amber once per second or when a system I/O error related to the device occurs. It is not recommended that you clean the drive head on a periodic basis; only when the drive requests to be cleaned. The LTO-5 tape drive monitors the amount of time between cleaning operations and displays the C when required.

Attention: Use only the recommended cleaning cartridge to clean the tape drive. Use of other than the recommended cleaning cartridges can damage your drive and might void the warranty.

Note: In Maintenance Mode, a flashing C with the solid amber Fault LED indicates that a cartridge should be inserted. This does not indicate that the drive head requires cleaning.

To clean the LTO tape drive, complete the following steps:

1. Make sure that the power is on to the LTO tape drive.
2. If a tape cartridge is in the tape drive, eject, and remove the cartridge.

Note: The IBM cleaning cartridge is designed to be used for 50 cleanings. Once a cleaning cartridge has been used to its maximum number of uses, the cartridge is considered expired. When the cleaning cartridge has been used 50 times, discard the cleaning cartridge. The LTO tape drive will detect, and automatically eject, an expired cartridge. Using the cleaning cartridge more than 50 times can cause debris to be deposited on the drive head, which may result in errors or inferior data quality.

3. Grasp the cleaning cartridge by the outer edges, with the label end out and the write protect switch to the left.
4. Slide the cartridge into the opening on the front of the LTO tape drive, as indicated by the arrow on the cartridge. Push the cartridge fully into the drive until the cartridge is engaged and the activity LED flashes green.

After the cleaning cartridge has been inserted, the remainder of the cleaning process is automatic. The tape drive:

- Loads the cleaning cartridge into the tape drive.
- Cleans the drive using the cleaning tape. Cleaning time may take from 30 seconds to 3 minutes, depending upon the number of times that the cleaning cartridge has been used.
- Unloads the cleaning cartridge when the cleaning operation is complete.

Note: If the cleaning operation is completed but the C in the SCD remains on, the cleaning cartridge might not be usable. Repeat the cleaning procedure with a new cleaning cartridge. If the C in the SCD still remains on, contact your authorized service provider.

To determine how many times a cleaning cartridge can be used, check the information printed on the cartridge. If you attempt to use a depleted cleaning cartridge the fault indicator will be turned on and the SCD displays 6 or 7 to indicate that the cleaning process was not done and the cleaning cartridge is no longer usable. If the fault indicator was lit and a C was in the SCD prior to the cleaning process, the indicators will stay on after the depleted cleaning cartridge is removed. If these indicators were off prior to inserting the depleted cleaning cartridge, they will turn off once the depleted cleaning cartridge is removed from the drive.

If a system error occurs, clean the drive and retry the operation. If the operation fails, replace the data cartridge, clean the drive again, and then retry the operation.

Loading and unloading tape cartridges

Learn about loading and unloading tape cartridges from this drive.

To avoid problems with loading and unloading tape cartridges use only one label on a cartridge. If the tape cartridge has too many labels or poorly placed labels, the drive-load mechanism might clog.

Loading a tape cartridge:

To load a tape cartridge, complete the following steps:

1. Make sure that the tape device power is on.
2. Grasp the tape cartridge by the outer edges, with the window side up and the write-protect switch facing you.

Note: Make sure that the write-protect switch is correctly set.

3. Slide the tape cartridge into the opening on the front of the device until the loading mechanism pulls the tape cartridge into the drive and the drive door closes.

To indicate that the load operation was successful, the ready status light comes on.

Unloading a tape cartridge:

To unload a tape cartridge, complete the following steps:

1. Make sure that the tape device power is on.
2. Press the Unload button. The device rewinds, unloads, and ejects the tape cartridge.

The process might take from 15 seconds to several minutes, depending on the position of the tape and the amount of data written. During this task, the status lights do the following sequence:

- The ready status light turns off.
- The activity status light flashes during the unload operation.
- The activity status light turns off when the cartridge is ejected from the tape drive.

Attention: An emergency eject and reset feature can be used to release the tape cartridge and to reset the drive. Use the emergency eject feature if the cartridge does not move correctly or if the unload process fails. The emergency eject and reset feature procedure might result in loss of data. To perform an emergency eject operation of the tape cartridge or a reset operation of the drive, press and hold the Unload button for at least 10 seconds. If a cartridge is in the drive, the cartridge automatically ejects without rewinding the tape.

Maintenance mode (FC 5638)

Learn about using maintenance mode functions on the 5638 tape drive.

Performing operations using the front panel

Perform maintenance operations by pushing the eject button while observing the status LED and the single-character display.

Entering maintenance mode

The drive must be in maintenance mode to run drive diagnostics or maintenance functions. To place the unit in maintenance mode:

1. Make sure that no cartridge is in the drive.
2. Press and hold the Unload Button for 6 seconds. A 0 appears in the Single-character Display (SCD), and the Fault Light turns amber.

Note: If a cartridge is in the tape drive, it will eject the first time that you press the Unload Button and the drive will not be placed in maintenance mode. To continue placing the drive in maintenance mode, perform the preceding step. While in Maintenance Mode, the drive will not accept a cartridge unless the drive requests it. The SCD will display a flashing C to indicate a cartridge needs to be inserted.

Maintenance functions cannot be performed concurrently with read or write operations. While in maintenance mode, the drive does not receive commands from the server.

Scrolling through maintenance options

With the drive in maintenance mode, press the eject push button at a rate of once per second. The single-character display code increments by one each time you press the eject push button.

Note: Do not press the eject push button more frequently than once per second or the selected maintenance function will occur instead of the desired scrolling operation.

After the last maintenance function is reached, the display code wraps to 0. Unassigned digits (B, D, and G) are not displayed when the options are incremented.

The following table lists the maintenance functions.

Table 14. Maintenance functions

Maintenance functions	Display code
Normal mode	None
Maintenance mode	0
Run drive diagnostics	1
Update drive firmware from FMR tape	2
Create FMR tape	3

Table 14. Maintenance functions (continued)

Maintenance functions	Display code
Force a drive dump (same as pressing the eject button for 10 or more seconds, except it does not cause a reset operation)	4
Copy drive dump to tape at the beginning of tape	5
Copy drive dump to tape	5-1
Copy drive dump to flash memory	5-8
Clear flash dump	5-3
No function	5 -0
Run host interface wrap test	6
Test the primary SAS port	6-1
Test the secondary SAS port	6-8
Test both primary and secondary SAS ports at the same time (requires a wrap plug in both ports)	6-3
Exit	6-0
Run RS-422 wrap test	7
Unmake FMR tape	8
Display error code log	9
Clear error code log	A
Insert cartridge into tape drive	C
Test cartridge and media	E
Write performance test	F
Test head	H
Fast read/write test	J
Load/unload test	L
Enable post-error reporting	P
Disable post-error reporting	U

Running a maintenance function

To run the maintenance function indicated by the character on the single-character display, press and hold the eject button for 2 seconds. The single digit flashes the selected maintenance function code during the running of the operation. If the drive runs the function successfully, the single-character display indicates 0. If the function fails, the status LED indicates continuous yellow and the single-character display indicates the reason for the error by displaying an error code. For a meaning of status lights and single-character display, see Table 11 on page 12.

Exiting maintenance mode

The drive must be in maintenance mode to run drive diagnostics or maintenance functions. To exit maintenance mode:

1. Press and hold the Unload Button for 3 or more seconds then release the button to take the drive out of maintenance mode. If no error is detected, 0 temporarily appears in the SCD, then goes blank. The drive then exits maintenance mode and the Status Light will return to Green.
2. If an error is detected, the SCD shows an error code but still exits maintenance mode. To clear the error, turn the power off, then on again.

Note: The drive also exits maintenance mode automatically after it completes a maintenance function or after 10 minutes if no action has occurred.

Running a dump operation when not in maintenance mode

To perform a drive dump operation, press and hold the eject button for 10 or more seconds. The microcode goes to its initialized state after a dump operation.

Note: Data from a dump operation is for use by trained personnel for problem determination.

Resetting the tape drive

You might need to reset your tape drive. Use the procedure in this topic to perform this task.

Use this information to reset your tape drive, without affecting server operation. Allow up to 2 minutes for the entire tape drive process to complete.

Attention: Resetting a tape drive before the current backup operation has completed can cause loss of customer data.

To reset the tape drive, complete the following steps:

1. Press and hold the eject button for 20 seconds, and then release the button. The LEDs on the drive flash while the reset function is in process.
2. After the LEDs stop flashing, wait approximately one minute for the drive to complete the reset operation. The drive is then ready to use.

Performing the internal self-test (FC 5638)

Use the information in this section to perform an internal self-test on your tape drive.

This procedure is designed to allow you to quickly perform a complete set of diagnostic tests on your LTO-4 tape drive, without impacting server operation. This 4-minute test can also be used to verify good performance of individual LTO tape cartridges. For an illustration of the tape drive and the LED status lights that are referred to in this procedure, see Table 11 on page 12.

Prerequisites

In order to perform the test you need a blank LTO-5 (Ultrium 5) data cartridge. If an Ultrium-5 data cartridge is not available, an Ultrium-4 cartridge can be substituted.

Performing the test

Follow these steps to perform the test:

Attention: Use a blank data cartridge to perform the test. During the test, the tape will be overwritten with a test pattern and all data on the tape will be destroyed.

1. Enter diagnostic mode by doing the following steps:
 - a. Verify that a tape cartridge is not loaded in the drive. To unload a cartridge, press the eject button on the front of the drive.
 - b. Press and hold the eject button for 7 seconds, until all LEDs become active, and then release the button.

The Ready LED will continue flashing, the Fault LED will remain on, and a 1 is displayed in the Single-character display (SCD). This combination indicates that the drive is waiting for a cartridge to be inserted.

2. Start the self-test by inserting a blank, Ultrium 5 data cartridge into the drive.
If an Ultrium-5 data cartridge is not available, an Ultrium-4 cartridge can be substituted.

Notes:

- A cartridge must be loaded within 15 seconds or the drive will automatically revert back to normal operation. If necessary, return to step 1 to reenter diagnostic mode.
- The test takes about 4 minutes.
- Use a cartridge that is not write-protected. If a write-protected cartridge is inserted while the drive is in diagnostic mode, the cartridge will be ejected. See Table 15.
- Self-testing can only be performed using a write-compatible (either Ultrium-4 or Ultrium-3) cartridge type, and with a cartridge that is not damaged. See Table 15.
- If a cleaning cartridge is inserted while the drive is in diagnostic mode, it will be ejected.

While self-testing is in progress, the LEDs will remain active and the following test steps are performed:

- The hardware test runs for about one minute. During that time, a static test is performed on the electrical components of the drive, and proper operation of the cartridge load/unload mechanism is verified.
- The write/read test runs for about three minutes.

Interpreting the results

Table 15. Interpreting the results of the self-test

Result	Description
Test passed	When self-testing has completed successfully and no problems were detected, the cartridge is unloaded from the drive and all LEDs are off. Proper function of both the drive and tape cartridge have been verified. The drive is no longer in diagnostic mode, and has been returned to normal operation. If the yellow Fault LED remains on and a C is displayed in the SCD, this combination indicates that self-testing has completed successfully but that cleaning is required. Clean the drive by inserting an IBM cleaning cartridge, part number 35L2086.
Drive failure	When a drive problem is detected, the cartridge remains loaded inside the drive, the yellow Fault LED flashes, and a 5 is displayed in the SCD. Replace the tape drive.
Media failure	When a media problem is detected, the cartridge remains loaded inside the drive, the yellow Fault LED remains on, and a 7 is displayed in the SCD. Repeat the self-test using another blank tape cartridge and discard the defective media.
Incorrect cartridge	When an incorrect tape cartridge is used for the test, the cartridge is unloaded, the yellow Fault LED remains on, and a P, 7, or J is displayed in the SCD. This can happen if the cartridge is: <ul style="list-style-type: none"> • Write-protected (P is displayed in the SCD.) • Damaged (7 is displayed in the SCD.) • Not write-compatible with the drive (J is displayed in the SCD.) Press the eject button to end the self-test and return the drive to normal operating mode. Then return to step 1 and run the self-test again using a suitable cartridge.

Returning to normal operation

When self-testing has completed successfully, the tape cartridge is unloaded. The drive is no longer in diagnostic mode and returns to normal operation.

When self-testing fails, the tape cartridge remains loaded inside the drive, and the drive remains in diagnostic mode. Press the eject button to unload tape cartridge and return drive to normal operation.

2.5/6.25 TB Ultrium 6 SAS tape drive (FC EU11)

Learn about the features of this media device.

Table 16. 2.5/6.25 TB Ultrium 6 SAS tape drive features

Feature	Description
Description	<p>The Ultrium 6 serial-attached SCSI (SAS) tape drive is a half-high tape drive designed for Open Systems backup and restore applications. These files can include multimedia, imaging, transaction processing, large databases, and other storage-intensive applications. It is the fourth generation in the Ultrium series of products, and is available with a SAS interface. The tape drive is an LTO Ultrium 6 standard interchange device. The drive reads tapes written by other Ultrium 6 drives, and writes to tapes that are readable by other Ultrium 6 drives. For an illustration of the drive, see Front view of tape drive.</p> <p>Characteristics:</p> <ul style="list-style-type: none"> • Single port 6 Gbps Serial Attached Small Computer Systems Interface (SAS) • Field Replaceable Unit (FRU) part number is 35P1049. For media part numbers, see “Tape cartridges (FC EU11)” on page 40. • Native storage capacity of 2.5 TB per cartridge (6.25 TB at 2.4:1 compression) • Custom card identification number (CCIN) is 63A0 • Data transfer rate: 160 MB per second native mode, 400 MB per second at 2.4:1 compression • Burst data transfer rate of 600 MB per second • 256 MB read-and-write cache • Support for encryption on Ultrium 4, 5, and 6 tape cartridges • Single-character display (SCD) operator panel • Ready and Fault status lights • Maintenance mode functions • Downward read and write compatibility with earlier LTO-type data cartridges. • Operation: Streaming • Half-height form factor • Can be used as a bootable device, depending on the host system configuration.
Tools	<p>The following tools and documentation are needed to complete the installation:</p> <ul style="list-style-type: none"> • A flat-blade screwdriver (if this device is not an auto-docking feature on your system) • Your system unit documentation, including any service documentation • Your operating system documentation <p>Contact the place of purchase if an item is missing or damaged.</p> <p>Note: If you are installing the auto-docking version of this device on your system, see your system documentation for information about the auto-docking feature.</p>
Media	<p>The drive reads and writes on Ultrium 6 and Ultrium 5 cartridges, and reads Ultrium 4 cartridges. The drive cannot read or write on Ultrium 3, Ultrium 2, and Ultrium 1 cartridges.</p> <p>Each Ultrium 6 tape cartridge can store up to 2.5 TB of uncompressed data, or up to 6.25 TB of compressed data.</p> <p>Note: The actual capacity varies depending on the application, the type of data, and the tape cartridge. When data compression is activated, 2.5 TB is typical and 6.25 TB is possible. The default setting of data compression is controlled by the host system. The user and the application software can control the activation or deactivation of the data compression setting. The drive can optimally achieve a 2:1 compression ratio.</p>

Table 16. 2.5/6.25 TB Ultrium 6 SAS tape drive features (continued)

Feature	Description
Related information	<p>Your package contains the following items:</p> <ul style="list-style-type: none"> • The tape drive • Media kit containing: <ul style="list-style-type: none"> – One cleaning cartridge – One test tape • Specific hardware for attaching the drive to your specific system, as detailed on the parts listing provided with your drive.

Eject button functions on the tape drive (FC EU11)

You might need to eject a tape, reset the drive, or place the drive in maintenance mode. Use the information in this topic to perform these tasks.

The drive has an eject button that enables you to perform the functions shown in the following table. The eject button is illustrated in Figure 2 on page 30.

Table 17. Eject button functions on the tape drive

Function	How to start the function
Reset the drive	<p>Press and hold the Unload Button until the drive begins the reset procedure, at which the status light will turn amber.</p> <p>Note: If a tape cartridge is loaded in the drive, the drive unloads the tape. Repeat the reset procedure after the tape is unloaded. The drive saves a dump of the current drive state, and then reboots to allow communication. Do not cycle power because this action erases the contents of the dump.</p>
Rewind the tape into the cartridge and eject the cartridge from the tape drive	<p>Press the Unload Button once. The status light flashes green while the drive is rewinding and unloading.</p> <p>Note: During a rewind and eject operation, the drive does not accept SCSI commands from the server.</p>
Place the tape drive in maintenance mode	<p>Ensure that the drive is unloaded. Then, press and hold the Unload Button for 6 seconds. The drive is in maintenance mode when the status light becomes solid amber and 0 is shown in the SCD.</p> <p>Note:</p> <ol style="list-style-type: none"> 1. While in maintenance mode, the drive does not accept SCSI commands. 2. If you attempt to enter maintenance mode with a cartridge in the drive, the drive will rewind and eject the cartridge. Remove the cartridge and repeat the steps for entering maintenance mode.
Scroll through the maintenance functions	<p>While in maintenance mode, press the Unload Button once per second to increment the display characters by one. When you reach the character of the diagnostic or maintenance function that you want (see Table 24 on page 43), press and hold the Unload Button for three seconds.</p>
Exit maintenance mode	<p>Press the Unload Button once per second until 0 is displayed. Then press and hold the Unload Button for three seconds. After the status light becomes solid green and the SCD becomes blank, the drive exits the maintenance mode.</p>

Table 17. Eject button functions on the tape drive (continued)

Function	How to start the function
Force a drive dump (The function is part of the maintenance mode.)	<p>Attention: If the drive detects a permanent error and displays an error code, it automatically forces a drive dump (also known as saving the firmware trace). If you force a drive dump, the existing dump is overwritten and data is lost. After you force a drive dump, do not turn off the power to the drive or you might lose the dump data.</p> <p>Choose one of the following procedures:</p> <ul style="list-style-type: none"> • If the drive is in maintenance mode (that is, the status light is solid amber), see Table 24 on page 43 to view the available maintenance functions. • If the drive is in operating mode (that is, status light is solid or flashing green), press and hold the Unload Button for 10 seconds. <p>If captured dump data exists, the drive places it into a dump area.</p>

Status lights (FC EU11)

You might need to read the status lights on your tape drive to determine the operating status of the drive. Use the information in this topic to perform this task.

Two status light-emitting diode (LED) lights and their ISO symbols are located on the drive as shown in the following figure:

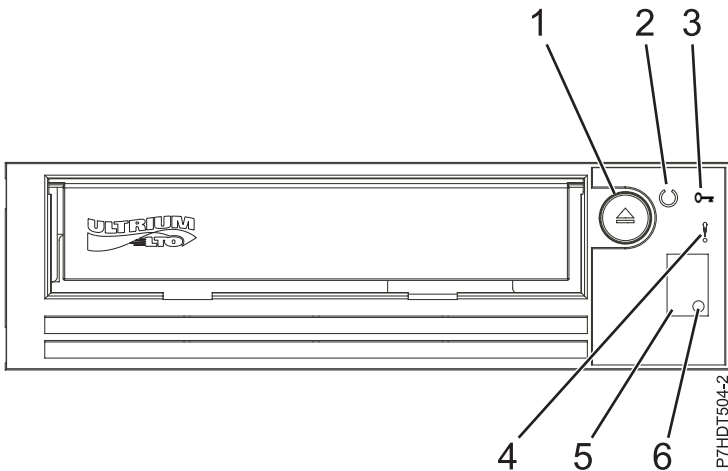

Figure 2. Front view of a half-high LTO tape drive

Table 18. Index number and the corresponding description of the front view of a half-high LTO tape drive

Index	Description
1	Eject button
2	Ready LED
3	Encrypt LED
4	Fault LED

Table 18. Index number and the corresponding description of the front view of a half-high LTO tape drive (continued)

Index	Description
5	Single-character display (SCD)
6	SCD light

Note:

1. The preventative maintenance cleaning frequency is approximately 100 tape motion hours or when the drive indicates that cleaning is required. Tape motion hours are defined as the time the tape drive is moving tape.
2. When a fault occurs, the drive causes AIX to log an information error (TAPE_ERR6) in the AIX log, indicating that the tape drive needs to be cleaned.
3. Use only IBM media. IBM only supports the use of IBM media and IBM cleaning cartridges.
4. When the tape drive indicates that the drive needs to be cleaned, it is the customer's responsibility to clean the tape drive with the recommended cleaning cartridge.

Table 19. Status light considerations

Mode	SCD	Ready LED (green)	Fault LED (amber)
Operational	Blank	On	Off
Activity (tape movement) in operational mode	Blank	Flashing	Off
Maintenance	Solid character	Off	On
Processing maintenance selection	Flashing character	Off	On
Error Condition	Solid character	Off	Flashing
Power-on / reset initialization	Random segments	Off	On

The following table lists the conditions of the status light and the single-character display (SCD). The table also provides an explanation of what each condition means.

Table 20. Meaning of status lights and single-character display (SCD)

Green ready status light	Amber fault status light	SCD	SCD Dot	Meaning
Off	Off	Off	Off	The drive has no power or is powered off.
Solid green	Off	Off	Off	The drive is powered on and in an idle state.
Flashing green (once per second)	Off	Off	Off	The drive is reading from the tape, writing to the tape, rewinding the tape, locating data on the tape, loading the tape, or unloading the tape.
Flashing green (once per second)	Off	Off	Off	If the drive contains a cartridge during the power-on cycle, the drive completes POST and slowly rewinds the tape. The process might take up to 10 minutes. The light stops blinking and becomes solid after the drive completes the recovery and ejects the cartridge.

Table 20. Meaning of status lights and single-character display (SCD) (continued)

Green ready status light	Amber fault status light	SCD	SCD Dot	Meaning
Off	Solid amber	Displaying an error code or maintenance mode function	On or off	The drive is displaying error codes from the error code log on the SCD. For information on error code and messages, see Table 21.
On or off	On or off	Displays random segments or is blank or displays random segments or displays 8 or is blank	Off	<p>During power on or during a drive reset, the drive front panel will displays the drive progress as follows:</p> <ol style="list-style-type: none"> 1. SCD displays random segments (no LEDs on). 2. SCD goes blank (green LED is on, amber LED is off) 3. SCD displays random segments (green LED is off, amber LED is on) 4. SCD displays 8 (green LED is off, amber LED is on) 5. SCD goes blank (green LED is on, amber LED is off) after a successful power on or reset. <p>If an error is detected during the power on or reset, the tape drive posts an error code to the SCD.</p>
Off	Solid amber	Displaying 0	Off/On	The drive is entering or exiting from maintenance mode.
Off	Solid amber	Flashing selected function	Off/On	The drive is processing the selected function while in maintenance mode.
Off	Flashing amber (once per second)	Displaying error code	Off	An error occurred. and the drive or media might require service, or it might require cleaning.
Off	Flashing amber	Displaying C	Off	The drive needs cleaning.
Off	Flashing amber	Displaying 2	Off	The drive is updating firmware.
Off	Flashing amber (twice per second)	Off	Off	The drive detected an error and is performing a firmware recovery. It resets automatically.
Off	Solid amber	Displaying C	Off	The drive is requesting a cartridge to be loaded.
Off	Flashing amber (twice per second)	Off	On	A drive dump is in the flash memory.

Table 21. LTO-6 tape drive error codes

Error Code	Cause and action
0	<p>No error occurred and no action is required. This code is displayed when diagnostics finish running and no error occurs.</p> <p>Note: The single-character display is blank during normal operation of the tape drive.</p>

Table 21. LTO-6 tape drive error codes (continued)

Error Code	Cause and action
1	<p>Temperature problem. The tape drive detected that the recommended operating temperature was exceeded. Complete one or more of the following actions:</p> <ul style="list-style-type: none"> • Ensure that the cooling fan is rotating and is quiet. If not, refer to your enclosure documentation. • Remove any blockage that prevents air from flowing freely through the tape drive. • Ensure that the operating temperature and airflow is within the specified range. <p>Clear the error code by power cycling the tape drive or placing the drive in maintenance mode. If the operating temperature and airflow are within the specified range, and the problem persists, replace the drive.</p>
2	<p>Power problem. The tape drive detected that the externally supplied power is outside the specified voltage limits (the tape drive is not operating). Complete the following actions:</p> <ul style="list-style-type: none"> • Ensure that the power connector is properly seated. • Ensure that the proper dc voltages are being applied within the tolerances allowed. • If the proper voltages are not being applied, service the power supply. • If the proper voltages are being applied, turn the tape drive off and on to see if the problem is repeated. • Replace the tape drive if the problem persists. <p>The error code clears after you place the tape drive in maintenance mode.</p>
3	<p>Firmware problem. The tape drive detected that a firmware error occurred. Complete the following actions:</p> <ul style="list-style-type: none"> • Collect a drive dump from one of the following: <ul style="list-style-type: none"> Note: Do not force a new dump. The tape drive has already created one. – Server’s host interface by using a device driver utility or system tool. For instructions about reading a drive dump from tape, see LTO storage website at http://www.ibm.com/storage/lto (http://www.ibm.com/storage/lto). – Ultrium Tape Drive. Copy and read a drive dump. • Power the tape drive off and on, and then retry the operation that produced the error. • If the problem persists, download new firmware and retry the operation. • If the problem persists, send the drive dump that you collected to your IBM Support Center. <p>The error code clears when you place the tape drive in maintenance mode.</p>

Table 21. LTO-6 tape drive error codes (continued)

Error Code	Cause and action
4	<p>Firmware or hardware problem. The tape drive detected that a firmware or tape drive hardware failure occurred. Complete the following actions:</p> <ul style="list-style-type: none"> • Collect a drive dump from one of the following: <ul style="list-style-type: none"> Note: Do not force a new dump. The tape drive has already created one. – Server’s host interface by using a device driver utility or system tool. For instructions about reading a drive dump from tape, see LTO storage website at http://www.ibm.com/storage/lto (http://www.ibm.com/storage/lto). – Ultrium Tape Drive. Copy and read a drive dump. • Turn the tape drive off and on, and then retry the operation that produced the error. The error code clears when you place the tape drive in maintenance mode. • If the problem persists, download new firmware and retry the operation. If new firmware is not available, replace the drive.
5	<p>Tape drive hardware problem. The drive detected that a tape path or read/write error occurred. To prevent damage to the drive or tape, the tape drive does not allow you to insert a cartridge if the current cartridge is successfully ejected. The error code might clear when you cycle power to the tape drive or place it in maintenance mode. If the problem persists, replace the drive.</p> <p>Note: Copy the drive dump to flash memory before returning the drive.</p>

Table 21. LTO-6 tape drive error codes (continued)

Error Code	Cause and action
6	<p>Tape drive or media error. The tape drive detected that an error occurred, but it cannot isolate the error to faulty hardware or to the tape cartridge. Ensure the tape cartridge is the correct media type:</p> <ul style="list-style-type: none"> • Ultrium-1, Ultrium-2, and Ultrium-3 tape cartridges are not supported in Ultrium-6 tape drives. • The drive does not accept an expired cleaning cartridge. • The drive does not accept a WORM cartridge when you run diagnostic tests in Maintenance Mode. • The drive does not write over existing data sets on a WORM cartridge. Ensure that you are appending data sets on WORM media rather than attempting to write over existing data sets. <p>If the tape cartridge is the correct media type, complete the following actions:</p> <p>For problems with writing data: If the problem occurred while the tape drive was writing data to the tape, retry the operation with a different cartridge:</p> <ul style="list-style-type: none"> • If the operation succeeds, the original cartridge was defective. Copy data from the defective cartridge and discard it. • If the operation fails and another tape drive is available, insert the cartridge into the other unit and retry the operation. <ul style="list-style-type: none"> – If the operation fails, discard the defective cartridge. – If the operation succeeds, insert a scratch data cartridge into the first unit and run the drive diagnostics. <ul style="list-style-type: none"> - If the diagnostics fail, replace the tape drive. - If the diagnostics succeed, the error was temporary. • If the operation fails and another tape drive is not available, insert a scratch data cartridge into the unit and run the drive diagnostics. <ul style="list-style-type: none"> – If the diagnostics fail, replace the tape drive. – If the diagnostics succeed, discard the cartridge. <p>If the problem occurs with multiple tape cartridges, run the drive diagnostics.</p> <p>The error code clears after you remove the tape cartridge or when place the tape drive in maintenance mode.</p>

Table 21. LTO-6 tape drive error codes (continued)

Error Code	Cause and action
	<p>For Problems with Reading Data:</p> <p>If the problem occurred while the tape drive was reading data from the tape, perform one of the following procedures:</p> <ul style="list-style-type: none"> • If another tape drive is available, insert the cartridge into the other unit and retry the operation. <ul style="list-style-type: none"> – If the operation fails, discard the defective cartridge. – If the operation succeeds, insert a scratch data cartridge into the first unit and run the drive diagnostics. <ul style="list-style-type: none"> - If the diagnostics fail, replace the tape drive. - If the diagnostics succeed, the error was temporary. • If another tape drive is not available, insert a scratch data cartridge into the unit and run the drive diagnostics. <ul style="list-style-type: none"> – If the diagnostics fail, replace the tape drive. – If the diagnostics succeed, discard the cartridge. <p>If the problem occurs with multiple tape cartridges, run the drive diagnostics.</p>

Table 21. LTO-6 tape drive error codes (continued)

Error Code	Cause and action
7	<p>Media error. The tape drive detected an error occurred because of a faulty tape cartridge or an invalid tape cartridge. Ensure that the tape cartridge is the correct media type:</p> <ul style="list-style-type: none"> • Ultrium-1, Ultrium-2, and Ultrium-3 tape cartridges are not supported in Ultrium-6 tape drives. • The drive does not accept an expired cleaning cartridge. • The drive does not accept a WORM cartridge when running diagnostic tests in maintenance mode. • The drive does not accept an FMR tape. • The drive does not write over existing data sets on a WORM cartridge. Ensure you are appending data sets on WORM media rather than attempting to write over existing data sets. <p>If the tape cartridge is the correct media type, try another tape cartridge. If the problem occurs with multiple tape cartridges, use the following procedure:</p> <p>If possible, run the tape cartridge in a different tape drive. If the operation in the other unit fails and 6 or 7 is displayed, replace the media. If the operation succeeds, run function code E, Test cartridge and media.</p> <p>Attention: When you run the Test cartridge and media diagnostic test, data on the suspect tape is overwritten. Use only a scratch data cartridge to run the test.</p> <ul style="list-style-type: none"> • If the diagnostic fails, replace the media. • If the diagnostic succeeds, clean the drive head and run function code 1, Run drive diagnostics. <ul style="list-style-type: none"> – If the drive diagnostic fails, replace the drive. – If the drive diagnostic succeeds, complete the operation that produced the initial media error. <p>The error code clears when you remove the tape cartridge or place the tape drive in maintenance mode.</p>
8	<p>Interface problem. The tape drive detected that a failure occurred in the tape drive's hardware or in the host bus.</p>
9	<p>Tape drive or RS-422 error. The tape drive detected that a failure occurred in the tape drive's hardware or in the RS-422 connection. The error code clears when you place the tape drive in maintenance mode.</p>

Table 21. LTO-6 tape drive error codes (continued)

Error Code	Cause and action
A	<p>Degraded operation. The tape drive detected that a problem occurred that degraded the operation of the tape drive, but it did not restrict continued use. If the problem persists, determine whether the problem is with the drive or the media.</p> <p>Note: The drive is usable, though the single-character display continues to indicate an error and the status LED flashes amber. The error code might clear when you cycle power to the tape drive or place it in maintenance mode. To determine whether the problem is with the drive hardware, or the tape media, complete the following steps:</p> <ol style="list-style-type: none"> 1. If possible, run the tape cartridge in a different drive. If the operation in the other drive fails and 6 or 7 is displayed, replace the media. If the operation succeeds, run the function code E, Test cartridge and media diagnostic. 2. If the Test cartridge and media diagnostic fails, replace the media. If it runs successfully, clean the failing drive and run the function code 1, Drive diagnostics. After you begin this test, the diagnostic test begins the loop sequence. Time the first loop by pressing the Unload button once to stop the diagnostics after the completion of the first loop, and then record the time it takes for the test to complete. Compare the recorded time with the approximate run time. If the test runs successfully but the execution time is significantly longer than the approximate run time, run function code F, Write performance test. If the Write performance test fails, replace the media and exit maintenance mode. If the drive diagnostics run successfully, perform the operation that produced the initial drive error. 3. If the problem persists, replace the drive. <p>If it is not possible to run the tape cartridge in a different drive, complete the following steps:</p> <ol style="list-style-type: none"> 1. Clean the failing drive and run the drive diagnostics. After you begin this test, the diagnostic test begins the loop sequence. Time the first loop by pressing the Unload button once to stop the diagnostics after the completion of the first loop, and then record the time it takes for the test to complete. Compare the recorded time with the approximate run time. If the test runs successfully but the execution time is significantly longer than the approximate run time, run function code F, Write performance test. If the write performance test fails, replace the media and exit maintenance mode. If the drive diagnostics run successfully, run the function code E, Test cartridge and media diagnostic. 2. If the test cartridge & media diagnostic fails, replace the media. If it runs successfully, perform the operation that produced the initial drive error. 3. If the problem persists, replace the drive.

Table 21. LTO-6 tape drive error codes (continued)

Error Code	Cause and action
C	<p>The tape drive needs to be cleaned. Clean the tape drive.</p> <p>The error code clears when you clean the tape drive or place it in maintenance mode.</p>
d	<p>Fiber AL_PA conflict. This function is not supported on this drive.</p>
e	<p>Encryption Error. This error code is displayed when the drive detects an error that is associated with an encryption operation. If the problem occurred while the tape drive was writing data to or reading data from tape, complete the following steps:</p> <ol style="list-style-type: none"> 1. Check the host application to ensure that the host application is providing the correct encryption key. <ul style="list-style-type: none"> • See the IBM Tape Device Drivers Encryption Support documentation and the IBM LTO Ultrium Tape Drive SCSI Reference documentation for the sense data returned for an encryption operation. • Retry the encryption operation after the host application problems are resolved. 2. Check the operation of the tape drive by resetting the drive and running POST. <ul style="list-style-type: none"> • If resetting the drive and POST fails, see the error code displayed on the SCD. • If resetting the drive and POST completes without errors, retry the encryption operation. 3. Check the media. <ul style="list-style-type: none"> • Ensure that the correct media is being used. Data encryption is supported with LTO Ultrium-4, Ultrium-5, and Ultrium-6 Data Cartridges only. • Retry the encryption operation with the tape cartridge in another encryption enabled drive. If the problem is repeated with the same tape cartridge in multiple drives, replace the media. <p>If the problem occurred while the tape drive was running POST or diagnostics, replace the drive.</p> <p>The error code clears with the first attempted write/read operation after the encryption key is changed, or when the drive is placed in maintenance mode.</p>
E	<p>Fiber Port offline. This error code is not supported on this drive.</p>
F	<p>Fiber Channel error. This error code is not supported on this drive.</p>
J	<p>Incompatible media. Media on which the drive cannot run commands has been loaded.</p>

Table 21. LTO-6 tape drive error codes (continued)

Error Code	Cause and action
P	Write operation to a write-protected cartridge has been attempted (this includes any attempt to overwrite a WORM-protected tape). Ensure that the tape cartridge is the correct media type. Write operations to Ultrium-4 tape cartridges are not supported in Ultrium-6 tape drives. If the tape cartridge is the correct media type, check the write-protect switch on the cartridge. The drive does not write to a write-protected cartridge. The error code clears when you remove the tape cartridge or place the tape drive in maintenance mode.
Bouncing o	Broken or excessive slack tape. The drive encountered a condition where it cannot unload the tape or determine that the tape is in the path of the head. Manual intervention is required.
Figure 8	Mid tape recovery. The drive is recovering from a power cycle with a tape in the drive. The Figure 8 error code is broken up with a countdown indicating progress in tenths of a percent to completion: 9, 8, 7, 6, 5, 4, 3, 2, 1.

Tape cartridges (FC EU11)

Learn about the types of tape cartridges that are available for this drive.

Table 22. LTO Ultrium data cartridges

Part number	Type of cartridge
00V7590	LTO-6 Data Cartridge (2.5 TB / 6.2 TB), Write/Read
46C2829	LTO-6 Test Cartridge (2.5 TB / 6.2 TB), Write/Read (not customer orderable)
Note: The preceding tapes are 810 m (2,657 ft).	
00V7591	LTO-6 Worm Data Cartridge
35L2086	Universal Cleaning Cartridge

Table 23. LTO-6 media

Feature code	Part number	Description
EU17	00V7590	2.5 TB Ultrium-6 Tape Cartridge
EU18	00V7590	A five pack of 2.5 TB Ultrium-6 Tape Cartridge

Attention: Do not attempt to bulk erase an LTO data cartridge for reuse. Bulk eraser devices cannot properly erase an LTO data cartridge, and they cause permanent damage to the cartridge.

Setting the write-protect switch

You might need to set the write-protect switch on the media. Use the information in this topic to perform this task.

The position of the write-protect switch on the tape cartridge determines when you can write to the tape as shown in the following figure. Before loading cartridges into magazines set the write-protect switch of each cartridge to enable or disable data recording:

- To enable data recording, slide the write-protect switch to the left so that the write-protect window is open.

- To disable data recording, slide the write-protect switch to the right so that the locked icon is shown on the switch.

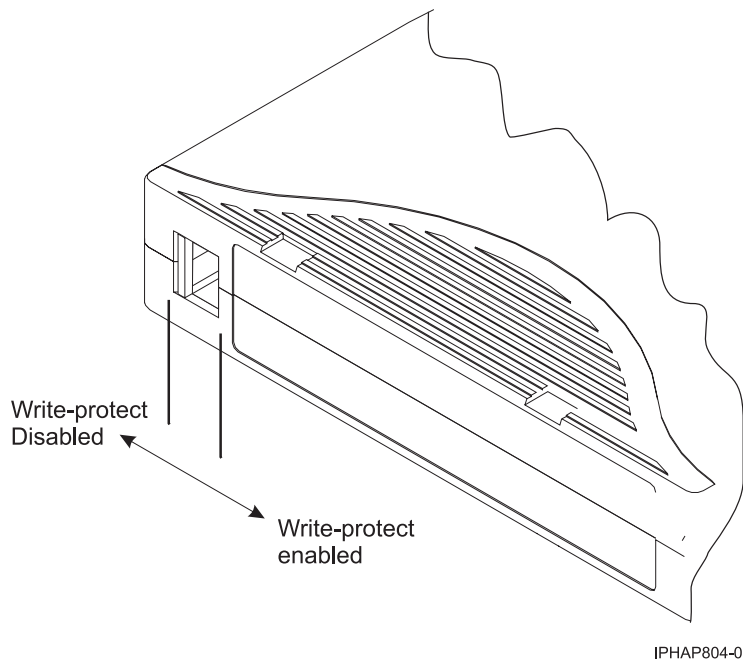

Figure 3. Setting the Write-Protect switch

Cleaning the tape drive (FC EU11)

You will need to clean your tape drive. Use the procedure in this topic to perform this task.

Clean the LTO-6 tape drive whenever C is displayed on the single-character display and the status light is flashing amber once per second or when a system I/O error related to the device occurs. Do not clean the drive head on a periodic basis. Only clean the drive head when the drive requests. The LTO-6 tape drive monitors the amount of time between cleaning operations and displays the C when required.

Attention: Use only the recommended cleaning cartridge to clean the tape drive. Use of other than the recommended cleaning cartridges can damage your drive and might void the warranty.

Note: In maintenance mode, a flashing C with the solid amber fault LED indicates that a cartridge must be inserted. This error code does not indicate that the drive head requires cleaning.

To clean the LTO tape drive, complete the following steps:

1. Make sure that the power is on to the LTO tape drive.
2. If a tape cartridge is in the tape drive, eject it and remove the cartridge.

Note: The IBM cleaning cartridge is designed to be used for 50 cleanings. After a cleaning cartridge has been used to its maximum number of uses, the cartridge is considered expired. When the cleaning cartridge has been used 50 times, discard the cleaning cartridge. The LTO tape drive detects and automatically ejects an expired cartridge. Use of the cleaning cartridge for more than 50 times can cause debris to be deposited on the drive head, which might result in errors or inferior data quality.

3. Grasp the cleaning cartridge by the outer edges, with the label end out and the write-protect switch to the left.
4. Slide the cartridge into the opening on the front of the LTO tape drive, as indicated by the arrow on the cartridge. Push the cartridge fully into the drive until the cartridge is engaged and the activity LED flashes green.

After the cleaning cartridge has been inserted, the remainder of the cleaning process is automatic. The tape drive completes the following actions:

- Loads the cleaning cartridge into the tape drive.
- Cleans the drive by using the cleaning tape. Cleaning time might take from 30 seconds to 3 minutes, depending on the number of times that the cleaning cartridge has been used.
- Unloads the cleaning cartridge when the cleaning operation is completed.

Note: If the cleaning operation is completed but the C in the SCD remains on, the cleaning cartridge might not be usable. Repeat the cleaning procedure with a new cleaning cartridge. If the C in the SCD still remains on, contact your authorized service provider.

To determine how many times a cleaning cartridge can be used, check the information printed on the cartridge. If you attempt to use a depleted cleaning cartridge, the fault indicator is turned on and the SCD displays 6 or 7 to indicate that the cleaning process was not done and that the cleaning cartridge is no longer usable. If the fault indicator was lit and a C was shown in the SCD prior to the cleaning process, the indicators stay on after the depleted cleaning cartridge is removed. If these indicators were off prior to inserting the depleted cleaning cartridge, they will turn off after the depleted cleaning cartridge is removed from the drive.

If a system error occurs, clean the drive and retry the operation. If the operation fails, replace the data cartridge, clean the drive again, and then retry the operation.

Loading and unloading tape cartridges

Learn about loading and unloading tape cartridges from this drive.

To avoid problems with loading and unloading tape cartridges use only one label on a cartridge. If the tape cartridge has too many labels or poorly placed labels, the drive-load mechanism might clog.

Loading a tape cartridge:

To load a tape cartridge, complete the following steps:

1. Make sure that the tape device power is on.
2. Grasp the tape cartridge by the outer edges, with the window side up and the write-protect switch facing you.

Note: Make sure that the write-protect switch is correctly set.

3. Slide the tape cartridge into the opening on the front of the device until the loading mechanism pulls the tape cartridge into the drive and the drive door closes.

To indicate that the load operation was successful, the ready status light comes on.

Unloading a tape cartridge:

To unload a tape cartridge, complete the following steps:

1. Make sure that the tape device power is on.
2. Press the Unload button. The device rewinds, unloads, and ejects the tape cartridge.

The process might take from 15 seconds to several minutes, depending on the position of the tape and the amount of data written. During this task, the status lights do the following sequence:

- The ready status light turns off.
- The activity status light flashes during the unload operation.
- The activity status light turns off when the cartridge is ejected from the tape drive.

Attention: An emergency eject and reset feature can be used to release the tape cartridge and to reset the drive. Use the emergency eject feature if the cartridge does not move correctly or if the unload process fails. The emergency eject and reset feature procedure might result in loss of data. To perform an emergency eject operation of the tape cartridge or a reset operation of the drive, press and hold the Unload button for at least 10 seconds. If a cartridge is in the drive, the cartridge automatically ejects without rewinding the tape.

Maintenance mode (FC EU11)

Learn about using maintenance mode functions on the EU11 tape drive.

Performing operations using the front panel

Perform maintenance operations by pushing the eject button while observing the status LED and the single-character display.

Entering maintenance mode

The drive must be in maintenance mode to run drive diagnostics or maintenance functions. To place the unit in maintenance mode complete the following steps:

1. Make sure that no cartridge is in the drive.
2. Press and hold the Unload Button for 6 seconds. A 0 is shown in the single-character display (SCD), and the fault light turns amber.

Note: If a tape cartridge is in the tape drive, the drive ejects the tape cartridge the first time that you press the Unload button, and the drive will not be placed in maintenance mode. To continue placing the drive in maintenance mode, perform the step 2 again. While in maintenance mode, the drive does not accept a tape cartridge unless the drive requests it. The SCD displays a flashing C to indicate that a tape cartridge needs to be inserted.

Maintenance functions cannot be performed concurrently with read or write operations. While in maintenance mode, the drive does not receive commands from the server.

Scrolling through maintenance options

With the drive in maintenance mode, press the eject button at a rate of once per second. The single-character display code increments by one each time you press the eject button.

Note: Do not press the eject button more frequently than once per second or the selected maintenance function processes instead of the desired scrolling operation.

After the last maintenance function is reached, the display code wraps to 0. Unassigned digits (B, D, and G) are not displayed when the options are incremented.

The following table lists the maintenance functions.

Table 24. Maintenance functions

Maintenance functions	Display code
Normal mode	None
Maintenance mode	0
Run drive diagnostics	1
Update the drive firmware from the field microcode replacement (FMR) tape	2
Create the FMR tape	3

Table 24. Maintenance functions (continued)

Maintenance functions	Display code
Force a drive dump (same as pressing the eject button for 10 or more seconds, except it does not cause a reset operation)	4
Copy the drive dump to tape at the beginning of tape	5
Copy the drive dump to tape	5-1
Copy the drive dump to flash memory	5-8
Clear the flash dump	5-3
No function	5 -0
Run the host interface wrap test	6
Test the primary SAS port	6-1
Test the secondary SAS port	6-8
Test both the primary and secondary SAS ports at the same time (requires a wrap plug in both ports)	6-3
Exit	6-0
Run the RS-422 wrap test	7
Unmake the FMR tape	8
Display the error code log	9
Clear the error code log	A
Insert the tape cartridge into the tape drive	C
Test the tape cartridge and the media	E
Write a performance test	F
Test the head	H
Fast read/write test	J
Load/unload test	L
Enable posterror reporting	P
Disable posterror reporting	U

Running a maintenance function

To run the maintenance function indicated by the character on the single-character display, press and hold the eject button for 2 seconds. The single digit flashes the selected maintenance function code during the running of the operation. If the drive runs the function successfully, the single-character display indicates 0. If the function fails, the status LED indicates continuous yellow and the single-character display indicates the reason for the error by displaying an error code. For more information, see Table 20 on page 31.

Exiting maintenance mode

The drive must be in maintenance mode to run drive diagnostics or maintenance functions.

To exit maintenance mode, complete the following steps:

1. Press and hold the Unload button for 3 or more seconds, and then release the button to take the drive out of maintenance mode. If no error is detected, 0 is shown temporarily in the SCD, and then the SCD goes blank. The drive then exits maintenance mode and the status light returns to green.

2. If an error is detected, the SCD shows an error code but still exits maintenance mode. To clear the error, turn the drive off and then on again.

Note: The drive also automatically exits maintenance mode after it completes a maintenance function or after 10 minutes if no action has occurred.

Running a dump operation when not in maintenance mode

To perform a drive dump operation, press and hold the eject button for 10 or more seconds. The microcode goes to its initialized state after a dump operation.

Note: Data from a dump operation is for use by trained personnel for problem determination.

Resetting the tape drive

You might need to reset your tape drive. Use the procedure in this topic to perform this task.

Use this information to reset your tape drive, without affecting server operation. Allow up to 2 minutes for the entire tape drive process to complete.

Attention: Resetting a tape drive before the current backup operation has completed can cause loss of customer data.

To reset the tape drive, complete the following steps:

1. Press and hold the eject button for 20 seconds, and then release the button. The LEDs on the drive flash while the reset function is in process.
2. After the LEDs stop flashing, wait approximately one minute for the drive to complete the reset operation. The drive is then ready to use.

Performing the internal self-test (FC EU11)

Use the information in this topic to perform an internal self-test on your tape drive.

Use this procedure to quickly perform a complete set of diagnostic tests on your LTO-6 tape drive, without impacting server operation. This 4-minute test can also be used to verify good performance of individual LTO tape cartridges. For an illustration of the tape drive and the LED status lights that are referred to in this procedure, see Figure 2 on page 30.

Prerequisites

To perform the test, you need a blank LTO-6 (Ultrium 6) data cartridge. If an Ultrium-6 data cartridge is not available, an Ultrium-5 cartridge can be substituted.

Performing the test

Attention: Use a blank data cartridge to perform the test. During the test, the tape is overwritten with a test pattern and all data on the tape is destroyed.

To perform the test, complete the following steps:

1. Enter diagnostic mode by completing the following substeps:
 - a. Verify that a tape cartridge is not loaded in the drive. To unload a cartridge, press the eject button on the front of the drive.
 - b. Press and hold the eject button for 7 seconds, until all LEDs become active, and then release the button.

The Ready LED continues to flash, the fault LED remains on, and a 1 is displayed in the single-character display (SCD). This combination indicates that the drive is waiting for a cartridge to be inserted.

- Start the self-test by inserting a blank, Ultrium 6 data cartridge into the drive.
If an Ultrium-6 data cartridge is not available, an Ultrium-5 cartridge can be substituted.

Notes:

- A cartridge must be loaded within 15 seconds or the drive automatically reverts back to normal operation. If necessary, return to step1 to reenter into diagnostic mode.
- The test takes about 4 minutes.
- Use a cartridge that is not write-protected. If a write protected cartridge is inserted while the drive is in diagnostic mode, the cartridge will be ejected. See Table 25.
- Self-testing can only be performed by using a write-compatible cartridge type (either Ultrium-6 or Ultrium-5), and with a cartridge that is not damaged. See Table 25.
- If a cleaning cartridge is inserted while the drive is in diagnostic mode, it will be ejected.

While self-testing is in progress, the LEDs remain active and the following test steps are performed:

- The hardware test runs for about 1 minute. During that time, a static test is performed on the electrical components of the drive, and proper operation of the cartridge load/unload mechanism is verified.
- The write/read test runs for about 3 minutes.

Interpreting the results

Table 25. Interpreting the results of the internal self-test

Result	Description
Test passed	When self-testing completes successfully and no problems are detected, the cartridge is unloaded from the drive and all LEDs are off. Proper functioning of both the drive and tape cartridge have been verified. The drive is no longer in diagnostic mode, and it returns to normal operation. If the yellow fault LED remains on and a C is displayed in the SCD, this combination indicates that self-testing has completed successfully but that cleaning is required. Clean the drive by inserting an IBM cleaning cartridge, part number 35L2086.
Drive failure	When a drive problem is detected, the cartridge remains loaded inside the drive, the yellow fault LED flashes, and a 5 is displayed in the SCD. Replace the tape drive.
Media failure	When a media problem is detected, the cartridge remains loaded inside the drive, the yellow fault LED remains on, and a 7 is displayed in the SCD. Repeat the self-test using another blank tape cartridge and discard the defective media.
Incorrect cartridge	When an incorrect tape cartridge is used for the test, the cartridge is unloaded, the yellow fault LED remains on, and a P, 7, or J is displayed in the SCD. These characters are displayed for the following reasons: <ul style="list-style-type: none"> The cartridge is write-protected (P is displayed in the SCD.) The cartridge is damaged (7 is displayed in the SCD.) The cartridge is not write-compatible with the drive (J is displayed in the SCD.) Press the eject button to end the self-test and return the drive to normal operating mode. Then, return to step1 and run the self-test again using a suitable cartridge.

Returning to normal operation

When self-testing has completed successfully, the tape cartridge is unloaded. The drive is no longer in diagnostic mode, and it returns to normal operation.

When self-testing fails, the tape cartridge remains loaded inside the drive, and the drive remains in diagnostic mode. Press the eject button to unload tape cartridge and to return drive to normal operation.

36/72 GB Data72 4 mm internal tape drive (FC 6258 or 5907)

Learn about the features of this media device.

Table 26. 36/72 GB Data72 4 mm internal tape drive features.

Note: FC 6258 is not supported for 8202-E4B, 8202-E4C, 8202-E4D, 8205-E6B, 8205-E6C, or 8205-E6D systems.

Feature	Description
Description	<p>The 36/72 GB Data72 4 mm Internal Tape Drive is a 5.25-inch, half-high, LVD or SAS drive, which provides a high capacity for save/restore and achieve functions. This tape drive uses IBM 4 mm data cartridges and is capable of compression, providing a capacity of up to 72 GB.</p> <p>Characteristics:</p> <ul style="list-style-type: none"> • FRU part number for FC 6258: 95P1988 • FRU part number for FC 5907: 23R2530 • Custom card identification number (CCIN): 63A0 • Capacity: 36 GB native mode, 72 GB (typical) compression mode • Form Factor: 5.25-inch half high • Media: DAT72, DDS4, and DDS3 media • Technology: Helical scan, rotating head • Operation: Streaming • Data Transfer Rate: 3 MBps native mode, 6 MBps (typical) compression • Interface for FC 6258: Low voltage differential • Interface for FC 5907: Serial-Attached SCSI • Compatibility: 12 GB mode (read/write), 20 GB (read/write), and 36 GB mode (read/write) • Attributes provided: 4 mm tape capability • Attributes required: One 1.6-inch (41 mm) half-high media bay and one SCSI internal LVD or SAS 16-bit address
Tools	<p>The following tools and documentation are needed to complete the installation:</p> <ul style="list-style-type: none"> • A flat-blade screwdriver (if this device is not an auto-docking feature on your system) • Your system unit documentation, including any service documentation • Your operating system documentation <p>Contact the place of purchase if an item is missing or damaged.</p> <p>Note: If you are installing the auto-docking version of this device on your system, the remainder of this section does not apply to your system. See your system documentation for information about the auto-docking feature.</p>
Media	<p>This tape drive uses 4mm data cartridges for saving and restoring system data. It is designed to use only DDS (Digital Data Storage) data cartridges. The cartridges are identified by one of the following DDS symbols:</p> <div style="text-align: center;">  <p>DDS3 Digital Data Storage Or DDS4 Digital Data Storage Or DAT72 Digital Data Storage</p> </div> <p>The tape drive reads and writes data to tape cartridges that are DDS-3, DDS-4, or DAT 72 format.</p> <p>Note: This tape drive only supports DDS-3, DDS-4, and DAT 72 tape cartridges. If any other cartridge is inserted in the drive, it will be ejected.</p> <p>This tape drive has been designed to operate with DDS media that meet the following standards of the European Computer Manufacturers Association (ECMA):</p> <ul style="list-style-type: none"> • ECMA-236 DDS-3 format • ECMA-288 DDS-4 format

Table 26. 36/72 GB Data72 4 mm internal tape drive features (continued).

Note: FC 6258 is not supported for 8202-E4B, 8202-E4C, 8202-E4D, 8205-E6B, 8205-E6C, or 8205-E6D systems.

Feature	Description
Related information	<p>Your package contains the following items:</p> <ul style="list-style-type: none"> • The tape drive • Media kit containing: <ul style="list-style-type: none"> – 1 cleaning cartridge – 1 test tape – Jumpers (located in a plastic bag) • Specific hardware for attaching the drive to your specific system, as detailed on the parts listing provided with your drive.

Cleaning the tape drive (FC 6258 or 5907)

You will need to clean your tape drive. Use the procedure in this topic to perform this task.

Clean the device whenever the Fault status light comes on or a system I/O error related to the device occurs.

Attention: Use only the recommended cleaning cartridge to clean the tape drive. Use of other than recommended cleaning cartridges can damage your drive and might void the warranty.

The tape drive will turn on the cleaning indicator for the following reasons:

- The tape drive exceeds internal preset error thresholds in the drive.
- A cleaning cartridge that has been used the maximum number of times is inserted in the drive. The cleaning indicator is turned on to indicate that the cleaning process was not done and the cleaning cartridge is no longer usable.
- The tape drive exceeds the maximum recommended time between cleaning.

The maximum recommended time between preventive-maintenance cleaning is 50 tape motion hours. Tape motion hours are defined as the time that the tape drive is moving tape. If the tape drive reaches 50 tape motion hours since the tape drive was last cleaned, the drive will turn on the cleaning required LED to indicate the drive needs cleaning. The tape drive will continue to operate but the tape drive should be cleaned at the next opportunity to insert a cleaning cartridge.

To clean the tape drive, complete the following steps:

1. Make sure that the power is on to the tape drive.
2. If a tape cartridge is in the tape drive, eject and remove the cartridge.

Note: Some cleaning cartridges have white dots on the window side that are designed to be used to log the use of the cartridge. Each time the cartridge is used, mark one of the dots on the cartridge with a pen or marker. When all of the dots have been marked, discard the cleaning cartridge.

3. Grasp the cleaning cartridge by the outer edges, with the window-side up and the write-protect switch facing you.
4. Slide the cartridge into the opening on the front of the drive until the loading mechanism pulls the cartridge into the drive and the drive door closes.

After the cleaning cartridge has been inserted, the remainder of the cleaning process is automatic. The tape drive does the following actions:

- Loads the cleaning cartridge into the tape drive.
- Cleans the drive by moving the cleaning tape forward for approximately 30 seconds.
- Unloads the cleaning cartridge when the cleaning operation is complete.

- Indicates a successful cleaning operation by turning off the Fault status light (if the Fault light was on prior to the cleaning process).

Note: If the cleaning operation completes but the Fault light remains on, repeat the cleaning procedure with a new cleaning cartridge. If the light still remains on, contact your authorized service provider.

To determine how many times a cleaning cartridge can be used, check the information printed on the cartridge. If you attempt to use a depleted cleaning cartridge, the tape drive automatically detects the error and ejects the cartridge. If the Fault status light was on prior to the cleaning process, it stays on; if the Fault light was off, the depleted cartridge causes the light to come on.

If a system error occurs, clean the drive and retry the operation. If the operation fails, replace the data cartridge, clean the drive again, then retry the operation.

Loading and unloading tape cartridges

Learn about loading and unloading tape cartridges from this drive.

To avoid problems with loading and unloading tape cartridges use only one label on a cartridge. If the tape cartridge has too many labels or poorly placed labels, the drive-load mechanism might clog.

Loading a tape cartridge:

To load a tape cartridge, complete the following steps:

1. Make sure that the tape device power is on.
2. Grasp the tape cartridge by the outer edges, with the window side up and the write-protect switch facing you.

Note: Make sure that the write-protect switch is correctly set.

3. Slide the tape cartridge into the opening on the front of the device until the loading mechanism pulls the tape cartridge into the drive and the drive door closes.

To indicate that the load operation was successful, the ready status light comes on.

Unloading a tape cartridge:

To unload a tape cartridge, complete the following steps:

1. Make sure that the tape device power is on.
2. Press the Unload button. The device rewinds, unloads, and ejects the tape cartridge.

The process might take from 15 seconds to several minutes, depending on the position of the tape and the amount of data written. During this task, the status lights do the following sequence:

- The ready status light turns off.
- The activity status light flashes during the unload operation.
- The activity status light turns off when the cartridge is ejected from the tape drive.

Attention: An emergency eject and reset feature can be used to release the tape cartridge and to reset the drive. Use the emergency eject feature if the cartridge does not move correctly or if the unload process fails. The emergency eject and reset feature procedure might result in loss of data. To perform an emergency eject operation of the tape cartridge or a reset operation of the drive, press and hold the Unload button for at least 10 seconds. If a cartridge is in the drive, the cartridge automatically ejects without rewinding the tape.

Setting the write-protect switch (FC 6258 or 5907)

You might need to set the write-protect switch on the media. Use the information in this topic to perform this task.

Attention: Do not attempt to change the write-protect settings after the tape cartridge is loaded in the drive because this might cause unpredictable results and might damage the tape or the drive.

The position of the write-protect switch on the tape cartridge determines when you can write to the tape.

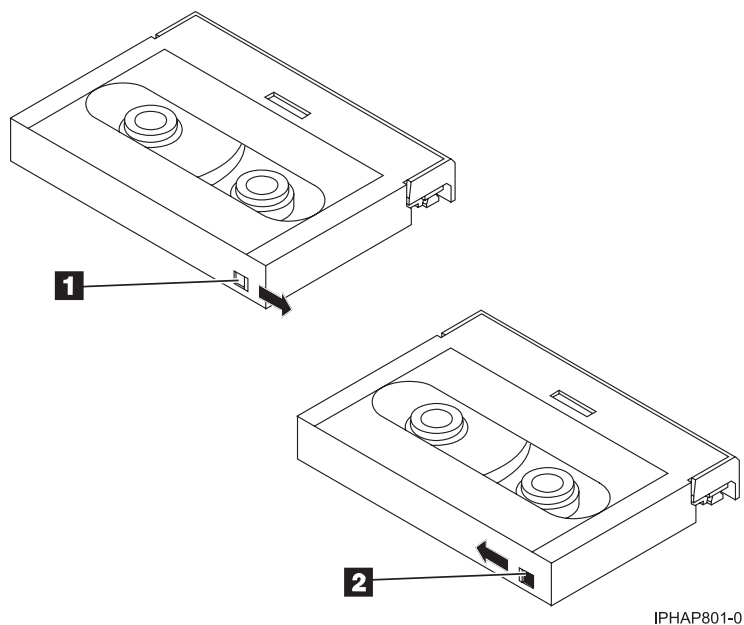

Table 27. Index number and the corresponding description of the tape cartridge

Index number	Description
1	When the switch is set to the right, data can be written to and read from the tape
2	When the switch is set to the left, data can only be read.

Status lights (FC 6258 or 5907)

You might need to read the status lights on your tape drive to determine the operating status of the drive. Use the information in this topic to perform this task.

The following illustration is a front view of the tape drive:

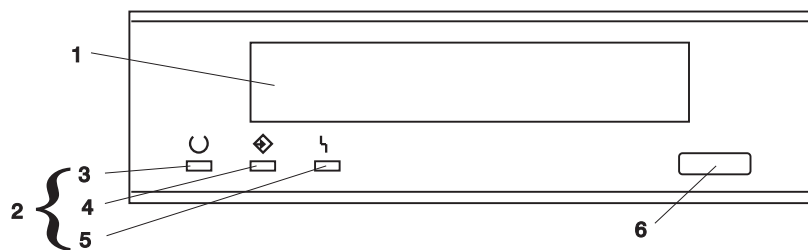

Figure 4. Front view of tape drive

Table 28. Index number and the description for the front view of the tape drive

Index number	Description
1	Tape drive door
2	Status lights

Table 28. Index number and the description for the front view of the tape drive (continued)

Index number	Description
3	Ready (green)
4	Active (green)
5	Fault (amber)
6	Unload/Reset button

The status lights and their ISO symbols are on the device as follows:

Ready

○ **Ready** (green)

Activity

⚡ **Activity** (green)

Fault

⌋ **Fault** (amber)

The combinations of the lights and their definitions are shown in the following table.

Table 29. Definition of status light combinations

Ready ○ Ready (green)	Activity ⚡ Activity (green)	Fault ⌋ Fault (amber)	Definition
Flashing	Off	Off	The power-on self-test (POST) is running or the test cartridge is running.
Off or On	Off or Flashing	On	The tape drive requires cleaning. See Cleaning the tape drive. <ul style="list-style-type: none"> • If the Ready light is on, a tape cartridge is in the drive. If the light is off, a cartridge is not in the drive. • If the Activity light flashes, a tape cartridge is in the drive and tape movement is occurring. If the light is off, no tape movement is occurring.
Off	Off	Off or On	One of the following conditions exists: <ul style="list-style-type: none"> • The power is off (Fault light is off). • The POST completed successfully, but no tape cartridge has been inserted. • If the Fault light is on, cleaning is required. See Cleaning the tape drive.

Table 29. Definition of status light combinations (continued)

Ready ○ Ready (green)	Activity ⚡ Activity (green)	Fault ⚠ Fault (amber)	Definition
On	Off or Flashing	Off or On	A data cartridge has been inserted. <ul style="list-style-type: none"> The device is ready to receive commands from the system (whether the Fault light is on or off). If the Fault light is on, cleaning is required. See Cleaning the tape drive. If the Activity light flashes, a tape cartridge is in the drive and tape movement is occurring. If the light is off, no tape movement is occurring.
On	Flashing	Off or On	The tape is in motion, and the device is running an operation or is cleaning.
Off	Off	Flashing	The device detected an internal fault that requires corrective action. <ol style="list-style-type: none"> Reset the error by turning the power off to the device, then turning it back on, or by holding down the Unload/Reset button for 8 seconds. If the Fault light still flashes after the reset, contact your service provider.

Notes:

- The device needs cleaning when the tape drive turns on the Fault status light (solid amber). The light turns on when the device exceeds a preset operating limit.
- The recommended preventive-maintenance cleaning frequency is approximately 50 tape motion hours. Tape motion hours are defined as the time that the tape drive is moving tape.
- When the Fault light turns on (solid amber), the device causes AIX to log an information error (TAPE_ERR6) in the AIX log, indicating that the tape drive needs to be cleaned.
- Use only quality media and cleaning cartridges.
- The device is designed to operate in typical office environments. Dirty environments or other poor environments might damage the tape drive. It is the customer's responsibility to provide the proper operating environment.
- When the tape drive indicates that the drive needs to be cleaned, it is the customer's responsibility to clean the tape drive with the recommended cleaning cartridge.
- If a tape cartridge that is not DDS-3, DDS-4, or DAT72 format is used, that cartridge will be immediately ejected as an incorrect cartridge type.

Tape cartridges (FC 6258 or 5907)

Learn about the types of tape cartridges that are available for this drive.

Available tape cartridges

Table 30. 4-mm Data Cartridges

IBM Part Number	Type of Cartridge	Native (uncompressed) Capacity
18P7912	DAT 72 Data Cartridge	36 GB
59H4456	4-mm Test Cartridge	--
21F8763	4-mm Cleaning Cartridge	--

Table 30. 4-mm Data Cartridges (continued)

IBM Part Number	Type of Cartridge	Native (uncompressed) Capacity
59H3465	Data Cartridge DDS3	12 GB
59H4458	Data Cartridge DDS4	20 GB

Most bulk eraser devices do not have the capability to erase the 4mm data cartridge. To correctly erase a 4mm data cartridge with a bulk eraser device, the erasure coercivity rating must be a minimum of 3900 Oersted.

Resetting the tape drive

You might need to reset your tape drive. Use the procedure in this topic to perform this task.

Use this information to reset your tape drive, without affecting server operation. Allow up to 2 minutes for the entire tape drive process to complete.

Attention: Resetting a tape drive before the current backup operation has completed can cause loss of customer data.

To reset the tape drive, complete the following steps:

1. Press and hold the eject button for 20 seconds, and then release the button. The LEDs on the drive flash while the reset function is in process.
2. After the LEDs stop flashing, wait approximately one minute for the drive to complete the reset operation. The drive is then ready to use.



80/160 GB DAT160 SAS tape drive (FC 5619)

Learn about the features of this media device.

For FC 5619, one of the following feature codes must be ordered to internally attach the tape drive:

- FC 3655 SAS cable group (logic and power) for HH SAS tape in 3.5" DASD backplane. The 3.5" DASD, uses the short cable with part number: 42R5814 (optional 42R5815)
- FC 3656 SAS cable group (logic and power) for HH SAS tape in SFF DASD backplane. The 2.5" DASD, uses a longer cable with part number: 46K5450 (replaces 42R5815)

Table 31. 80/160 GB DAT160 SAS tape drive features

Features	Description
Description	<p>The 80/160 GB DAT160 SAS tape drive is a 5.25-inch, half-high, SAS drive, which provides a high capacity for save/restore and achieve functions. To see an illustration of this drive, see Figure 5 on page 57. This tape drive uses IBM DAT160, 4 mm data cartridges and is compression capable, providing a capacity of up to 160 GB with 2:1 compression ratio.</p> <p>Characteristics:</p> <ul style="list-style-type: none"> • FRU part number: 23R9723 • Custom card identification number (CCIN): 63A0 • Media part numbers: see “Tape cartridges (FC 5619)” on page 59 • Capacity: 80 GB native mode, 160 GB (typical) compression mode • Form factor: 5.25-inch half high • Media: DAT160, DAT72, and DDS4 media • Technology: helical scan, rotating head • Operation: streaming • Data transfer rate: 6 MBps native mode, 12 MBps (typical) compression • Interface: integrated, internal SAS • Compatibility: DDS4 (read/write), DAT72 (read/write), and DAT160 (read/write) • Attributes provided: 4 mm tape capability, test cartridge, cleaning cartridge, and a data cartridge • Attributes required: One 1.6-inch (41 mm) half-high media bay and one integrated, internal SAS
Tools	<p>The following tools and documentation are needed to complete the installation:</p> <ul style="list-style-type: none"> • A flat-blade screwdriver (if this device is not an auto-docking feature on your system) • Your system unit documentation, including any service documentation • Your operating system documentation <p>Contact the place of purchase if an item is missing or damaged.</p> <p>Note: If you are installing the auto-docking version of this device on your system, see your system documentation for information about the auto-docking feature.</p>
Media	<p>This tape drive uses 4 mm data cartridges for saving and restoring system data. It is designed to use only DDS (Digital Data Storage) data cartridges. The cartridges are identified by one of the following DDS symbols:</p> <div style="text-align: center;">  Digital Data Storage Or  Digital Data Storage Or  Digital Data Storage </div> <p>The tape drive reads and writes data to tape cartridges that are in the DDS4, DAT72, or DAT160 format.</p>
Related information	<p>Your package contains the following items:</p> <ul style="list-style-type: none"> • The tape drive • Media kit containing: <ul style="list-style-type: none"> – One cleaning cartridge – One test tape • Specific hardware for attaching the drive to your specific system, as detailed on the parts listing provided with your drive, or as follows: <ul style="list-style-type: none"> – Drive slide assembly 2 rails – 4 Screws (Flat blade)

Cleaning the tape drive (FC 5619)

You will need to clean your tape drive. Use the procedure in this topic to perform this task.

Clean the device whenever the Fault status light comes on or a system I/O error related to the device occurs.

Attention: Use only the recommended cleaning cartridge to clean the tape drive. Use of other than recommended cleaning cartridges can damage your drive and might void the warranty. The cleaning cartridge for this drive is P/N 23R5638. The cartridge is physically larger than previous cleaning cartridges and it is the only cleaning cartridge that can be used in this drive. The older, narrower cleaning cartridges do not work in the 5619 tape drive and are ejected from the drive without cleaning the drive.

The tape drive will turn on the cleaning indicator for the following reasons:

- The tape drive exceeds internal preset error thresholds in the drive.
- A cleaning cartridge that has been used the maximum number of times is inserted in the drive. The cleaning indicator is turned on to indicate that the cleaning process was not done and the cleaning cartridge is no longer usable.
- The tape drive exceeds the maximum recommended time between cleaning.

The maximum recommended time between preventive-maintenance cleaning is 50 tape motion hours. Tape motion hours are defined as the time that the tape drive is moving tape. If the tape drive reaches 50 tape motion hours since the tape drive was last cleaned, the drive will turn on the cleaning required LED to indicate the drive needs cleaning. The tape drive will continue to operate but the tape drive should be cleaned at the next opportunity to insert a cleaning cartridge.

Note: Operating the tape drive in a low-humidity environment causes the drive to request cleaning more often than in normal humidity environment. In extreme low-humidity conditions of less than 15% relative humidity, the tape drive might request cleaning every 10 tape motion hours or even more frequently. For this reason, it is best not to use the tape drive in extremely low-humidity environments.

To clean the tape drive, complete the following steps:

1. Make sure that the power is on for the tape drive.
2. If a tape cartridge is in the tape drive, eject and remove the cartridge.
3. Grasp the cleaning cartridge by the outer edges, with the window-side up and the write-protect switch facing you.
4. Slide the cartridge into the opening on the front of the drive until the loading mechanism pulls the cartridge into the drive and the drive door closes.

After the cleaning cartridge has been inserted, the remainder of the cleaning process is automatic. The tape drive does the following actions:

- Loads the cleaning cartridge into the tape drive.
- Cleans the drive by moving the cleaning tape forward for approximately 30 seconds.
- Unloads the cleaning cartridge when the cleaning operation is complete.
- Indicates a successful cleaning operation by turning off the Cleaning status light (if the Cleaning light was on prior to the cleaning process. Otherwise, the Cleaning light remains solid to indicate that the cleaning cartridge is no longer usable. Obtain a new cleaning cartridge and repeat the process.)

Note: If the cleaning operation completes but the Cleaning light remains on, repeat the cleaning procedure with a new cleaning cartridge. If the light still remain on, contact your authorized service representative.

If you attempt to use a depleted cleaning cartridge, the drive automatically detects the error and ejects the cartridge. If the Cleaning status light was on prior to the cleaning process, it stays on; if the Cleaning light was off, the depleted cartridge causes the light to come on.

If a system error occurs, clean the drive and retry the operation. If the operation fails, replace the data cartridge, clean the drive again, then retry the operation.

Loading and unloading tape cartridges

Learn about loading and unloading tape cartridges from this drive.

To avoid problems with loading and unloading tape cartridges use only one label on a cartridge. If the tape cartridge has too many labels or poorly placed labels, the drive-load mechanism might clog.

Loading a tape cartridge:

To load a tape cartridge, complete the following steps:

1. Make sure that the tape device power is on.
2. Grasp the tape cartridge by the outer edges, with the window side up and the write-protect switch facing you.

Note: Make sure that the write-protect switch is correctly set.

3. Slide the tape cartridge into the opening on the front of the device until the loading mechanism pulls the tape cartridge into the drive and the drive door closes.

To indicate that the load operation was successful, the ready status light comes on.

Unloading a tape cartridge:

To unload a tape cartridge, complete the following steps:

1. Make sure that the tape device power is on.
2. Press the Unload button. The device rewinds, unloads, and ejects the tape cartridge.

The process might take from 15 seconds to several minutes, depending on the position of the tape and the amount of data written. During this task, the status lights do the following sequence:

- The ready status light turns off.
- The activity status light flashes during the unload operation.
- The activity status light turns off when the cartridge is ejected from the tape drive.

Attention: An emergency eject and reset feature can be used to release the tape cartridge and to reset the drive. Use the emergency eject feature if the cartridge does not move correctly or if the unload process fails. The emergency eject and reset feature procedure might result in loss of data. To perform an emergency eject operation of the tape cartridge or a reset operation of the drive, press and hold the Unload button for at least 10 seconds. If a cartridge is in the drive, the cartridge automatically ejects without rewinding the tape.

Setting the write-protect switch (FC 5619)

You might need to set the write-protect switch on the media. Use the information in this topic to perform this task.

Attention: Do not attempt to change the write-protect settings after the tape cartridge is loaded in the drive because this might cause unpredictable results and might damage the tape or the drive.

The position of the write-protect switch on the tape cartridge determines when you can write to the tape.

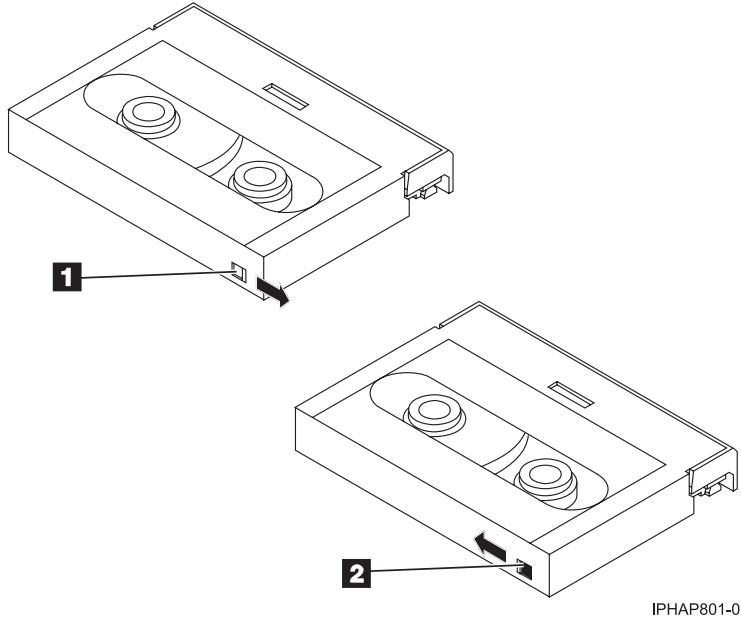

Table 32. Index number and the corresponding description of the tape drive

Index number	Description
1	When the switch is set to the right, data can be written to and read from the tape.
2	When the switch is set to the left, data can only be read.

Status lights (FC 5619)

You might need to read the status lights on your tape drive to determine the operating status of the drive. Use the information in this topic to perform this task.

The following illustration is a front view of the tape drive:

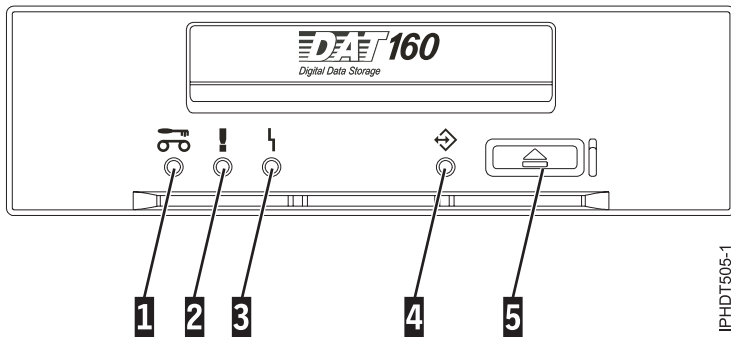

Figure 5. Front-view of tape drive

Table 33. Index number and the corresponding description for the front view of the tape drive

Index number	Description
1	Cleaning LED (amber)
2	Media fault LED (amber)
3	Drive fault LED (amber)

Table 33. Index number and the corresponding description for the front view of the tape drive (continued)

Index number	Description
4	Ready/Activity LED (green)
5	Unload/Reset button

The combinations of the lights and their definitions are shown in the following table.

Table 34. Definition of status light combinations









Activity	Cleaning (amber) 	Media fault (amber) 	Drive fault (amber) 	Ready/Activity (green) 
Power on LED test (2.0 seconds)	On	On	On	On
Power on self-test (POST) activity	Off	Off	Off	Flashing
POST failed	Off	Off	Flashing	Off
POST passed	On ¹ or off	Off	Off	Off
Data cartridge loading	On ¹ or off	Off	Off	Flashing
Data cartridge loaded, no activity	On ¹ or off	On ² or off	Flashing ³ or off	On
Data cartridge loaded, activity	On ¹ or off	On ² or off	Flashing ³ or off	Flashing
Data cartridge unloading	On ¹ or off	On ² or off	Flashing ³ or off	Flashing
Data cartridge ejected	On ¹ or off	On or off	Flashing ³ or off	Off
Cleaning cartridge loaded, activity	On	Off	Flashing ³ or off	Flashing
Cleaning succeeded, cleaning cartridge ejected	Off	Off	Flashing ³ or off	Off
Cleaning failed, cleaning cartridge ejected	On ¹	On	Flashing ³ or off	Off
Unrecoverable drive failure ⁴	On ¹ or off	On or off	Flashing	Flashing
Unrecoverable media failure ⁴	On ¹	On	Off	Flashing, on, or off
Firmware download: download and reprogram	Flashing	Off	Off	Flashing
Firmware download: possible unload	See Data cartridge unloading			
Firmware download: reset in 1 second	On	On	On	On
Firmware download: self-test	See Power on self-test activity, and then see either POST passed or POST failed.			

Table 34. Definition of status light combinations (continued)

Activity	Cleaning (amber) 	Media fault (amber) 	Drive fault (amber) 	Ready/Activity (green) 
Firmware download reprogram failure	Off	Off	Flashing	Off
SCSI diagnostics test in progress	See Data cartridge loaded, activity			
SCSI diagnostics test passed	See Data cartridge loaded, no activity			
SCSI diagnostics test failed, tape ejected	On	On	On	Flashing
	After data cartridge ejects, see Data cartridge ejected.			
Tape diagnostics test in progress	See Data cartridge loading and then:			
	Flashing	Off	Off	Flashing
Tape diagnostics test passed, tape ejected	Off	Off	Off	Flashing
	After data cartridge ejects, see Data cartridge ejected.			
Tape diagnostics test failed, tape ejected	On	On	On	Flashing
	After data cartridge ejects, see Data cartridge ejected.			
<p>¹ A solid amber Cleaning LED indicates that the drive needs cleaning. The drive will continue to function but needs cleaning as soon as possible. Do not ignore the indicator by cycling the power to turn it off.</p> <p>² The media has reached the end of its useful life and should be replaced. Any data should be copied to a new cartridge as soon as possible.</p> <p>³ Flashing in this state indicates a problem with write/read performance.</p> <p>⁴ An unrecoverable drive failure is an error condition that results in the drive not being able to function unless initiator, operator, or service intervention is applied. An unrecoverable drive failure is usually the result of a hardware error condition. One of the following actions is needed to clear the flashing fault LED:</p> <ul style="list-style-type: none"> • Hard SCSI reset • Cartridge emergency eject • Power cycle • Retry firmware download <p>An unrecoverable media failure is usually the result of a defective cartridge, media, or cartridge state, and will require the drive to eject the cartridge (if possible) to clear the On LED.</p>				

Tape cartridges (FC 5619)

Learn about the types of tape cartridges that are available for this drive.

Available tape cartridges

Table 35. 4 mm data cartridges

IBM part number	Type of cartridge
23R5635 (cartridge feature code 5689)	DAT160 80 GB Data Cartridge
23R5636	4 mm Test Cartridge
23R5638	4 mm Cleaning Cartridge (Only use the DAT160 cleaning cartridge on the DAT160 tape drive)

Most bulk eraser devices do not have the capability to erase the 4 mm data cartridge.

Resetting the tape drive

You might need to reset your tape drive. Use the procedure in this topic to perform this task.

Use this information to reset your tape drive, without affecting server operation. Allow up to 2 minutes for the entire tape drive process to complete.

Attention: Resetting a tape drive before the current backup operation has completed can cause loss of customer data.

To reset the tape drive, complete the following steps:

1. Press and hold the eject button for 20 seconds, and then release the button. The LEDs on the drive flash while the reset function is in process.
2. After the LEDs stop flashing, wait approximately one minute for the drive to complete the reset operation. The drive is then ready to use.



80/160 GB DAT160 USB tape drive (FC EU16)

Learn about the features of this media device.

Table 36. 80/160 GB DAT160 USB tape drive features

Feature	Description
Description	<p>The 80/160 GB DAT160 USB Tape Drive is a 5.25-inch, half-high, USB drive, which provides a high capacity for save/restore and achieve functions. To see an illustration of this drive, see Figure 6 on page 64. This tape drive uses IBM DAT160, 4 mm data cartridges and is compression capable, providing a capacity of up to 160 GB with 2:1 compression ratio.</p> <p>Characteristics:</p> <ul style="list-style-type: none">• FRU part number: 46C2458• Custom card identification number (CCIN): 63A0• Media part numbers: see “Tape cartridges (FC EU16)” on page 66• Capacity: 80 GB native mode, 160 GB (typical) compression mode• Form factor: 5.25-inch half high• Media: DAT160, DAT72, and DDS4 media• Technology: helical scan, rotating head• Operation: streaming• Data transfer rate: 6 MBps native mode, 12 MBps (typical) compression• Interface: integrated, internal USB• Compatibility: DDS4 (read/write), DAT72 (read/write), and DAT160 (read/write)• Attributes provided: 4 mm tape capability, test cartridge, cleaning cartridge, and a data cartridge• Attributes required: One 1.6-inch (41 mm) half-high media bay and one integrated, internal USB
Tools	<p>The following tools and documentation are needed to complete the installation:</p> <ul style="list-style-type: none">• A flat-blade screwdriver (if this device is not an auto-docking feature on your system)• Your system unit documentation, including any service documentation• Your operating system documentation <p>Contact the place of purchase if an item is missing or damaged.</p> <p>Note: If you are installing the auto-docking version of this device on your system, see your system documentation for information about the auto-docking feature.</p>

Table 36. 80/160 GB DAT160 USB tape drive features (continued)

Feature	Description
Media	<p>This tape drive uses 4 mm data cartridges for saving and restoring system data. It is designed to use only DDS (Digital Data Storage) data cartridges. The cartridges are identified by one of the following DDS symbols:</p> <div style="text-align: center;">  Or  Or  </div> <p>The tape drive reads and writes data to tape cartridges that are in the DDS4, DAT72, or DAT160 format.</p>
Related information	<p>Your package contains the following items:</p> <ul style="list-style-type: none"> • The tape drive • Media kit containing: <ul style="list-style-type: none"> – One cleaning cartridge – One test tape • Specific hardware for attaching the drive to your specific system, as detailed on the parts listing provided with your drive.

Cleaning the tape drive (FC EU16)

You will need to clean your tape drive. Use the procedure in this topic to perform this task.

Clean the device whenever the Fault status light comes on or a system I/O error related to the device occurs.

Attention: Use only the recommended cleaning cartridge to clean the tape drive. Use of other than recommended cleaning cartridges can damage your drive and might void the warranty. The cleaning cartridge for this drive is P/N 23R5638. The cartridge is physically larger than previous cleaning cartridges and it is the only cleaning cartridge that can be used in this drive. The older, narrower cleaning cartridges do not work in the 5619 tape drive and are ejected from the drive without cleaning the drive.

The tape drive will turn on the cleaning indicator for the following reasons:

- The tape drive exceeds internal preset error thresholds in the drive.
- A cleaning cartridge that has been used the maximum number of times is inserted in the drive. The cleaning indicator is turned on to indicate that the cleaning process was not done and the cleaning cartridge is no longer usable.
- The tape drive exceeds the maximum recommended time between cleaning.

The maximum recommended time between preventive-maintenance cleaning is 50 tape motion hours. Tape motion hours are defined as the time that the tape drive is moving tape. If the tape drive reaches 50 tape motion hours since the tape drives was last cleaned, the drive will turn on the cleaning required LED to indicate the drive needs cleaning. The tape drive will continue to operate but the tape drive should be cleaned at the next opportunity to insert a cleaning cartridge.

Note: Operating the tape drive in a low-humidity environment causes the drive to request cleaning more often than in normal humidity environment. In extreme low-humidity conditions of less than 15% relative humidity, the tape drive might request cleaning every 10 tape motion hours or even more frequently. For this reason, it is best not to use the tape drive in extremely low-humidity environments.

To clean the tape drive, complete the following steps:

1. Make sure that the power is on for the tape drive.

2. If a tape cartridge is in the tape drive, eject and remove the cartridge.
3. Grasp the cleaning cartridge by the outer edges, with the window-side up and the write-protect switch facing you.
4. Slide the cartridge into the opening on the front of the drive until the loading mechanism pulls the cartridge into the drive and the drive door closes.

After the cleaning cartridge has been inserted, the remainder of the cleaning process is automatic. The tape drive does the following actions:

- Loads the cleaning cartridge into the tape drive.
- Cleans the drive by moving the cleaning tape forward for approximately 30 seconds.
- Unloads the cleaning cartridge when the cleaning operation is complete.
- Indicates a successful cleaning operation by turning off the Cleaning status light (if the Cleaning light was on prior to the cleaning process. Otherwise, the Cleaning light remains solid to indicate that the cleaning cartridge is no longer usable. Obtain a new cleaning cartridge and repeat the process.)

Note: If the cleaning operation completes but the Cleaning light remains on, repeat the cleaning procedure with a new cleaning cartridge. If the light still remain on, contact your authorized service representative.

If you attempt to use a depleted cleaning cartridge, the drive automatically detects the error and ejects the cartridge. If the Cleaning status light was on prior to the cleaning process, it stays on; if the Cleaning light was off, the depleted cartridge causes the light to come on.

If a system error occurs, clean the drive and retry the operation. If the operation fails, replace the data cartridge, clean the drive again, then retry the operation.

Loading and unloading tape cartridges

Learn about loading and unloading tape cartridges from this drive.

To avoid problems with loading and unloading tape cartridges use only one label on a cartridge. If the tape cartridge has too many labels or poorly placed labels, the drive-load mechanism might clog.

Loading a tape cartridge:

To load a tape cartridge, complete the following steps:

1. Make sure that the tape device power is on.
2. Grasp the tape cartridge by the outer edges, with the window side up and the write-protect switch facing you.

Note: Make sure that the write-protect switch is correctly set.

3. Slide the tape cartridge into the opening on the front of the device until the loading mechanism pulls the tape cartridge into the drive and the drive door closes.

To indicate that the load operation was successful, the ready status light comes on.

Unloading a tape cartridge:

To unload a tape cartridge, complete the following steps:

1. Make sure that the tape device power is on.
2. Press the Unload button. The device rewinds, unloads, and ejects the tape cartridge.

The process might take from 15 seconds to several minutes, depending on the position of the tape and the amount of data written. During this task, the status lights do the following sequence:

- The ready status light turns off.
- The activity status light flashes during the unload operation.

- The activity status light turns off when the cartridge is ejected from the tape drive.

Attention: An emergency eject and reset feature can be used to release the tape cartridge and to reset the drive. Use the emergency eject feature if the cartridge does not move correctly or if the unload process fails. The emergency eject and reset feature procedure might result in loss of data. To perform an emergency eject operation of the tape cartridge or a reset operation of the drive, press and hold the Unload button for at least 10 seconds. If a cartridge is in the drive, the cartridge automatically ejects without rewinding the tape.

Setting the write-protect switch (FC EU16)

You might need to set the write-protect switch on the media. Use the information in this topic to perform this task.

Attention: Do not attempt to change the write-protect settings after the tape cartridge is loaded in the drive because this might cause unpredictable results and might damage the tape or the drive.

The position of the write-protect switch on the tape cartridge determines when you can write to the tape.

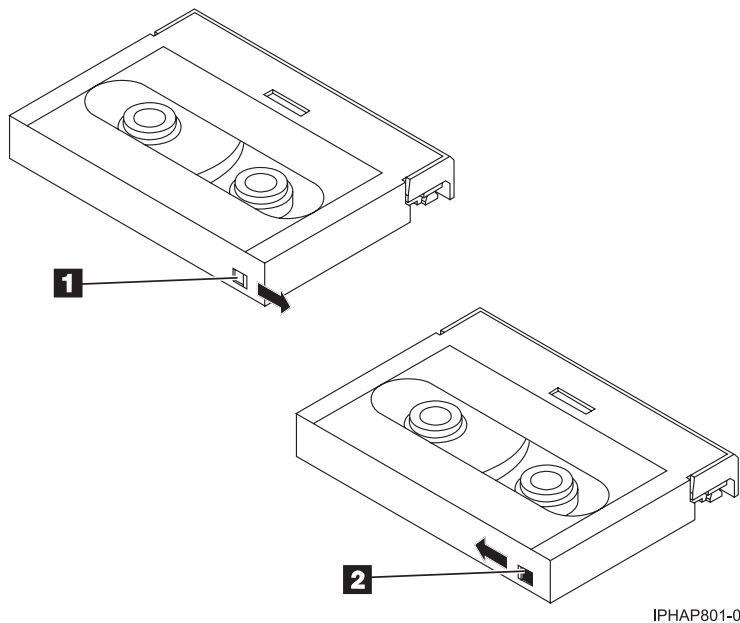

Table 37. Index number and the corresponding description of the tape cartridge

Index number	Description
1	When the switch is set to the right, data can be written to and read from the tape.
2	When the switch is set to the left, data can only be read.

Status lights (FC EU16)

You might need to read the status lights on your tape drive to determine the operating status of the drive. Use the information in this topic to perform this task.

The following illustration is a front view of the tape drive:

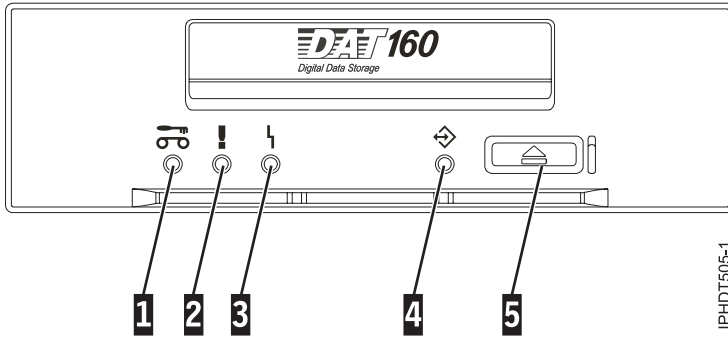





Figure 6. Front view of tape drive





Table 38. Index number and the corresponding description for the front view of the tape drive

Index number	Description
1	Cleaning LED (amber)
2	Media fault LED (amber)
3	Drive fault LED (amber)
4	Ready/Activity LED (green)
5	Unload/Reset button

The combinations of the lights and their definitions are shown in the following table.

Activity	Cleaning (amber) 	Media fault (amber) 	Drive fault (amber) 	Ready/Activity (green)
Power on LED test (2.0 seconds)	On	On	On	On
Power on self-test (POST) activity	Off	Off	Off	Flashing
POST failed	Off	Off	Flashing	Off
POST passed	On ¹ or off	Off	Off	Off
Data cartridge loading	On ¹ or off	Off	Off	Flashing
Data cartridge loaded, no activity	On ¹ or off	On ² or off	Flashing ³ or off	On
Data cartridge loaded, activity	On ¹ or off	On ² or off	Flashing ³ or off	Flashing
Data cartridge unloading	On ¹ or off	On ² or off	Flashing ³ or off	Flashing
Data cartridge ejected	On ¹ or off	On or off	Flashing ³ or off	Off
Cleaning cartridge loaded, activity	On	Off	Flashing ³ or off	Flashing
Cleaning succeeded, cleaning cartridge ejected	Off	Off	Flashing ³ or off	Off

Activity	Cleaning (amber) 	Media fault (amber) 	Drive fault (amber) 	Ready/Activity (green) 
Cleaning failed, cleaning cartridge ejected	On ¹	On	Flashing ³ or off	Off
Unrecoverable drive failure ⁴	On ¹ or off	On or off	Flashing	Flashing
Unrecoverable media failure ⁴	On ¹	On	Off	Flashing, on, or off
Firmware download: download and reprogram	Flashing	Off	Off	Flashing
Firmware download: possible unload	See Data cartridge unloading			
Firmware download: reset in 1 second	On	On	On	On
Firmware download: self-test	See Power on self-test activity, and then see either POST passed or POST failed.			
Firmware download reprogram failure	Off	Off	Flashing	Off
SCSI diagnostics test in progress	See Data cartridge loaded, activity			
SCSI diagnostics test passed	See Data cartridge loaded, no activity			
SCSI diagnostics test failed, tape ejected	On	On	On	Flashing
	After data cartridge ejects, see Data cartridge ejected.			
Tape diagnostics test in progress	See Data cartridge loading and then:			
	Flashing	Off	Off	Flashing
Tape diagnostics test passed, tape ejected	Off	Off	Off	Flashing
	After data cartridge ejects, see Data cartridge ejected.			
Tape diagnostics test failed, tape ejected	On	On	On	Flashing
	After data cartridge ejects, see Data cartridge ejected.			

Activity	Cleaning (amber) 	Media fault (amber) 	Drive fault (amber) 	Ready/Activity (green) 
<p>¹ A solid amber Cleaning LED indicates that the drive needs cleaning. The drive will continue to function but needs cleaning as soon as possible. Do not ignore the indicator by cycling the power to turn it off.</p> <p>² The media has reached the end of its useful life and should be replaced. Any data should be copied to a new cartridge as soon as possible.</p> <p>³ Flashing in this state indicates a problem with write/read performance.</p> <p>⁴ An unrecoverable drive failure is an error condition that results in the drive not being able to function unless initiator, operator, or service intervention is applied. An unrecoverable drive failure is usually the result of a hardware error condition. One of the following actions is needed to clear the flashing fault LED:</p> <ul style="list-style-type: none"> • Hard SCSI reset • Cartridge emergency eject • Power cycle • Retry firmware download <p>An unrecoverable media failure is usually the result of a defective cartridge, media, or cartridge state, and will require the drive to eject the cartridge (if possible) to clear the On LED.</p>				

Tape cartridges (FC EU16)

Learn about the types of tape cartridges that are available for this drive.

Available tape cartridges

Table 39. 4 mm data cartridges

IBM part number	Type of cartridge
23R5635 (cartridge feature code 5689)	DAT160 80 GB Data Cartridge
23R5636	4 mm Test Cartridge
23R5638	4 mm Cleaning Cartridge (Only use the DAT160 cleaning cartridge on the DAT160 tape drive)

Most bulk eraser devices do not have the capability to erase the 4 mm data cartridge.

Resetting the tape drive

You might need to reset your tape drive. Use the procedure in this topic to perform this task.

Use this information to reset your tape drive, without affecting server operation. Allow up to 2 minutes for the entire tape drive process to complete.

Attention: Resetting a tape drive before the current backup operation has completed can cause loss of customer data.

To reset the tape drive, complete the following steps:

1. Press and hold the eject button for 20 seconds, and then release the button. The LEDs on the drive flash while the reset function is in process.
2. After the LEDs stop flashing, wait approximately one minute for the drive to complete the reset operation. The drive is then ready to use.

160/320 GB DAT320 SAS tape drive (FC 5661)

Learn about the features of this media device.

Table 40. 160/320 GB DAT320 SAS tape drive features

Feature	Description
Description	<p>The 160/320 GB DAT320 SAS Tape Drive is a 5.25-inch, half-high, SAS drive, which provides a high capacity for save/restore and achieve functions. To see an illustration of this drive, see Figure 7 on page 70. This tape drive uses IBM DAT320, 4 mm data cartridges and is compression capable, providing a capacity of up to 320 GB with 2:1 compression ratio.</p> <p>Characteristics:</p> <ul style="list-style-type: none"> • Drive part number: 46C1932 • FRU part number: 46C1933 • Custom card identification number (CCIN): 63A0 • Media part numbers: see “Tape cartridges (FC 5661)” on page 73 • Capacity: 160 GB native mode, 320 GB (typical) compression mode • Form factor: 5.25-inch half high • Media: DAT320, DAT160 • Technology: helical scan, rotating head • Operation: streaming • Data transfer rate: 12 MBps native mode • Microcode level: VS12 • Interface: integrated, internal SAS with right-angle connector. • Compatibility: DAT160 (read/write) and DAT320 (read/write) <p>Note: DAT160 media is more abrasive than DAT320 media and can be used for occasional use only.</p> <ul style="list-style-type: none"> • Attributes provided: DAT320 tape, test cartridge, and a cleaning cartridge • Attributes required: One 1.6-inch (41 mm) half-high media bay and Feature Code 3657, SAS cable with right angle connector.
Tools	<p>The following tools and documentation are needed to complete the installation:</p> <ul style="list-style-type: none"> • A flat-blade screwdriver (if this device is not an auto-docking feature on your system) • Your system unit documentation, including any service documentation • Your operating system documentation <p>Contact the place of purchase if an item is missing or damaged.</p> <p>Note: If you are installing the auto-docking version of this device on your system, see your system documentation for information about the auto-docking feature.</p>
Media	<p>This tape drive uses 4 mm data cartridges for saving and restoring system data. It is designed to use only DDS (Digital Data Storage) data cartridges. The cartridges are identified by one of the following DDS symbols:</p> <div style="text-align: center;">  <p>The image shows two logos for Digital Data Storage (DDS) cartridges. On the left is the 'DAT 160' logo, and on the right is the 'DAT 320' logo. Both logos feature the word 'DAT' in a stylized font with horizontal lines through it, followed by the numbers '160' or '320'. Below each logo is the text 'Digital Data Storage'. To the right of the 'DAT 320' logo is a vertical text string 'P7HDT501-0'.</p> </div> <p>The tape drive reads and writes data to tape cartridges that are in the DAT160 or DAT320 format.</p>

Table 40. 160/320 GB DAT320 SAS tape drive features (continued)

Feature	Description
Related information	<p>Your package contains the following items:</p> <ul style="list-style-type: none"> • The tape drive • Media kit containing: <ul style="list-style-type: none"> – One cleaning cartridge – One test cartridge • Specific hardware for attaching the drive to your specific system, as detailed on the parts listing provided with your drive.

Cleaning the tape drive (FC 5661)

You will need to clean your tape drive. Use the procedure in this topic to perform this task.

Clean the device whenever the Fault status light comes on or a system I/O error related to the device occurs.

Attention: Use only the recommended cleaning cartridge to clean the tape drive. Use of other than recommended cleaning cartridge damages your drive and voids the warranty. The cleaning cartridge for this drive is P/N 46C1937 and it is the only cleaning cartridge that can be used in this drive.

The tape drive will turn on the cleaning indicator for the following reasons:

- The tape drive exceeds internal preset error thresholds in the drive.
- A cleaning cartridge that has been used the maximum number of times is inserted in the drive. The cleaning indicator is turned on to indicate that the cleaning process was not done and the cleaning cartridge is no longer usable.
- The tape drive exceeds the maximum recommended time between cleaning.

The tape drive determines how much to clean the drive and uses less or more cleaning media depending on what the drive determines is necessary. The average number of uses expected from a cleaning cartridge is 50, the minimum is 27, and the maximum is 70.

The maximum recommended time between preventive-maintenance cleaning is 50 tape motion hours. Tape motion hours are defined as the time that the tape drive is moving tape. If the tape drive reaches 50 tape motion hours since the tape drive was last cleaned, the drive turns on the cleaning required LED to indicate the drive needs cleaning. The tape drive will continue to operate but the tape drive must be cleaned at the next opportunity to insert a cleaning cartridge.

Note: Operating the tape drive in a low-humidity environment causes the drive to request cleaning more often than in normal humidity environment. In extreme low-humidity conditions of less than 15% relative humidity, the tape drive might request cleaning every 10 tape motion hours or even more frequently. For this reason, it is best not to use the tape drive in extremely low-humidity environments.

To clean the tape drive, complete the following steps:

1. Make sure that the power is on for the tape drive.
2. If a tape cartridge is in the tape drive, eject and remove the cartridge.
3. Grasp the cleaning cartridge by the outer edges, with the window-side up and the write-protect switch facing you.
4. Slide the cartridge into the opening on the front of the drive until the loading mechanism pulls the cartridge into the drive and the drive door closes.

After the cleaning cartridge has been inserted, the remainder of the cleaning process is automatic. The tape drive does the following actions:

- Loads the cleaning cartridge into the tape drive.
- Cleans the drive by moving the cleaning tape forward for approximately 30 seconds.
- Unloads the cleaning cartridge when the cleaning operation is complete.
- Indicates a successful cleaning operation by turning off the Cleaning status light (if the Cleaning light was on prior to the cleaning process. Otherwise, the Cleaning light remains solid to indicate that the cleaning cartridge is no longer usable. Obtain a new cleaning cartridge and repeat the process.)

Note: If the cleaning operation completes but the Cleaning light remains on, repeat the cleaning procedure with a new cleaning cartridge. If the light still remain on, contact your authorized service representative.

If you attempt to use a depleted cleaning cartridge, the drive automatically detects the error and ejects the cartridge. If the Cleaning status light was on prior to the cleaning process, it stays on; if the Cleaning light was off, the depleted cartridge causes the light to come on.

If a system error occurs, clean the drive and retry the operation. If the operation fails, replace the data cartridge, clean the drive again, then retry the operation.

Loading and unloading tape cartridges

Learn about loading and unloading tape cartridges from this drive.

To avoid problems with loading and unloading tape cartridges use only one label on a cartridge. If the tape cartridge has too many labels or poorly placed labels, the drive-load mechanism might clog.

Loading a tape cartridge:

To load a tape cartridge, complete the following steps:

1. Make sure that the tape device power is on.
2. Grasp the tape cartridge by the outer edges, with the window side up and the write-protect switch facing you.

Note: Make sure that the write-protect switch is correctly set.

3. Slide the tape cartridge into the opening on the front of the device until the loading mechanism pulls the tape cartridge into the drive and the drive door closes.

To indicate that the load operation was successful, the ready status light comes on.

Unloading a tape cartridge:

To unload a tape cartridge, complete the following steps:

1. Make sure that the tape device power is on.
2. Press the Unload button. The device rewinds, unloads, and ejects the tape cartridge.

The process might take from 15 seconds to several minutes, depending on the position of the tape and the amount of data written. During this task, the status lights do the following sequence:

- The ready status light turns off.
- The activity status light flashes during the unload operation.
- The activity status light turns off when the cartridge is ejected from the tape drive.

Attention: An emergency eject and reset feature can be used to release the tape cartridge and to reset the drive. Use the emergency eject feature if the cartridge does not move correctly or if the unload process fails. The emergency eject and reset feature procedure might result in loss of data. To perform an emergency eject operation of the tape cartridge or a reset operation of the drive, press and hold the Unload button for at least 10 seconds. If a cartridge is in the drive, the cartridge automatically ejects without rewinding the tape.

Setting the write-protect switch (FC 5661)

You might need to set the write-protect switch on the media. Use the information in this topic to perform this task.

Attention: Do not attempt to change the write-protect settings after the tape cartridge is loaded in the drive because this might cause unpredictable results and might damage the tape or the drive.

The position of the write-protect switch on the tape cartridge determines when you can write to the tape.

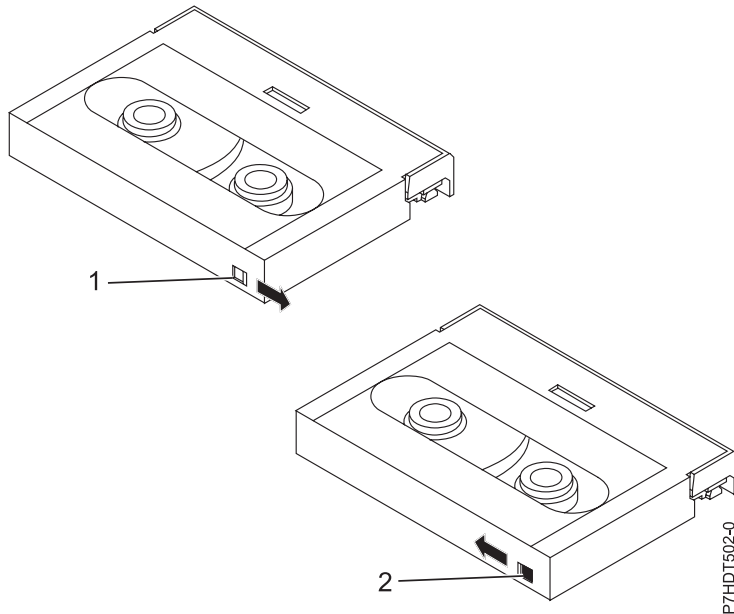

Table 41. Index number and the corresponding description of the tape cartridge

Index number	Description
1	When the switch is set to the right, data can be written to and read from the tape.
2	When the switch is set to the left, data can only be read.

Status lights (FC 5661)

You might need to read the status lights on your tape drive to determine the operating status of the drive. Use the information in this topic to perform this task.

The following illustration is a front view of the tape drive:

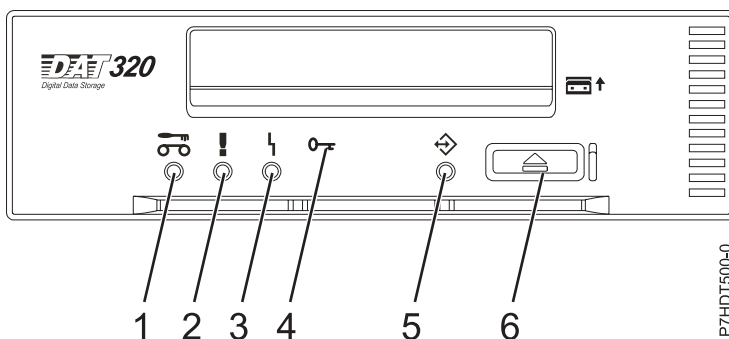

Figure 7. Front view of tape drive

Table 42. Index number and the corresponding description for the front view of the tape drive

Index number	Description
1	Cleaning LED (amber)
2	Media fault LED (amber)
3	Drive fault LED (amber)
4	Encrypt LED (blue)
5	Ready/Activity LED (green)
6	Unload/Reset button

The combinations of the lights and their definitions are shown in the following table.

Table 43. Definition of status light combinations





Activity	Cleaning (amber) 	Tape fault (amber) 	Drive fault (amber) 	Encrypt fault (blue) 	Ready/ Activity (green) 
Power on LED test (5 seconds)	On	On	On	On	On
Power on self-test (POST) activity	Off	Off	Off	Off	Flash_2Hz
POST failed	Off	Off	Flash_2Hz	Off	Off
POST passed	On ¹ or off	Off	Off	Off	Off
Data cartridge					
Loading	On ¹ or off	Off	Off ⁸	Off	Flash_2Hz
Loaded, no activity	On ¹ or off	On ² or off	Flash_2Hz ⁴ or off	Off	On
Loaded, activity	On ¹ or off	On ² or off	Flash_2Hz ⁴ or off	Off	Flash_2Hz
Unloading	On ¹ or off	On ² or off	Flash_2Hz ⁴ or off	Off	Flash_2Hz
Ejected	On ¹ or off	On ² or off	Flash_2Hz ⁴ or off	Off	Off
Cleaning cartridge					
Loading, cleaning, unloading	On	Off	Flash_2Hz ⁴ or off	Off	Flash_2Hz
Ejected, clean success	Off	Off	Flash_2Hz ⁴ or off	Off	Off
Ejected, clean failure	On ¹	On ³	Flash_2Hz ⁴ or off	Off	Off
Unrecoverable media failure	On	On	Off	Off	Flash_2Hz or on or off
Firmware download					
Unload (if cartridge present)	See: Data Cartridge Unloading				
Download and reprogram	Flash_8Hz	Off	Off	Off	Flash_8Hz
Reset (5 seconds)	On	On	On	Off	On
Self-tests	See Power on self-test activity, and then see either POST passed or POST failed.				

Table 43. Definition of status light combinations (continued)











Activity	Cleaning (amber) 	Tape fault (amber) 	Drive fault (amber) 	Encrypt fault (blue) 	Ready/ Activity (green) 	
Firmware download fail ⁵ Note: This is cleared when other activity occurs ¹⁰	Off	Off	Flash_2Hz	Off	Off	
Diagnostic tape test						
Eject initiated primed drive to treat inserted data cartridge as diagnostic tape	Normal	Normal	Normal	Off	Flash_4Hz	
Initiated by SCSI diagnostic using normal data tape	In progress	See Data cartridge: Loaded, activity				
	Passed ⁷	See Data cartridge: Loaded, no activity				
	Failed ⁶	On	On	On	Normal	Flash_4Hz
Until tape ejected. See Data cartridge: ejected						
Using tape with diagnostic tape recognition holes	In progress	See Data cartridge: loading				
		Flash_4Hz	Off	Off	Normal	Flash_4Hz
	Passed ⁹ , tape ejected	Off	Off	Off	Normal	Flash_4Hz
		See Data cartridge: ejected				
	Failed ⁶	On	On	On	Normal	Flash_4Hz
See Data cartridge: ejected						
Encryption related¹¹						
No encryption or decryption activity	Normal	Normal	Normal	Off	Normal	
Encryption parameters are loaded; the drive is ready to read/write encrypted data	Normal	Normal	Normal	On	Normal	
Drive is reading/writing encrypted data	Normal	Normal	Normal	Flash_2Hz	Flash_2Hz	
Encryption parameters loaded, but the drive is reading/writing unencrypted data.	Normal	Normal	Normal	On	Flash_2Hz	
Encryption related error exists	Normal	Normal	Flash_4Hz	Flash_4Hz	Normal	

Table 43. Definition of status light combinations (continued)

Activity	Cleaning (amber) 	Tape fault (amber) 	Drive fault (amber) 	Encrypt fault (blue) 	Ready/ Activity (green) 
<p>¹ CLEAN_LED activation in this state means the drive needs cleaning. It will be set due to hard or soft errors. It is cleared upon successful cleaning cartridge usage. State is preserved over a power cycle.</p> <p>² TAPE_LED activation in this state can only be due to a repeated hard or soft error. It is cleared when data or cleaning cartridge is inserted.</p> <p>³ TAPE_LED activation in this state can only be due to a cleaning cartridge failure. It is cleared when data or cleaning cartridge is inserted.</p> <p>⁴ DRIVE_LED activation in this state can only be due to the media management algorithm determining that the drive has a serious problem with regard to its write/read performance. It is not preserved over power cycle.</p> <p>⁵ The firmware download failed. The firmware download should be retried. Note: This does not happen if the problem is simply due to an incorrect firmware image being attempted, for example, the DAT72 image being downloaded to DAT160. The purpose of this LED sequence is to show the user that the download failed and to retry the download. Examples of this are if the host failed to send all the data or if the hardware was unable to complete the task. This sequence is not activated if the microcode headers are invalid or if the code fails its checksum.</p> <p>⁶ The LED states for SCSI/tape diagnostic failed remain until the ejection is completed and then either the Eject button is pressed or another tape is inserted.</p> <p>⁷ The LEDs revert to nondiagnostic tape state (for example, for a loaded data tape).</p> <p>⁸ If the drive LED is on, the tape load is not initiated.</p> <p>⁹ The LED states for tape diagnostic passed remain until the auto-eject operation is completed.</p> <p>¹⁰ The firmware download failed LEDs continue to show until another change to the LEDs is required that is due to either cartridge loading or unloading or due to tape motion. So it is not SCSI commands, as such, that clear this but the response of the LED display to those SCSI commands. Tape access commands cause cartridge or tape motion to occur.</p> <p>¹¹ IBM does not support encryption in their systems, but the LED activity is included in the event that a user inserts a tape with encrypted data.</p>					

Tape cartridges (FC 5661)

Learn about the types of tape cartridges that are available for this drive.

Available tape cartridges

Table 44. 4 mm data cartridges

IBM part number	Type of cartridge
46C1936	DAT320 160 GB Data Cartridge
46C1938	4 mm Test Cartridge
46C1937	4 mm Cleaning Cartridge (Only use on the DAT320 tape drive)

Most bulk eraser devices do not have the capability to erase the 4 mm data cartridge.

Resetting the tape drive

You might need to reset your tape drive. Use the procedure in this topic to perform this task.

Use this information to reset your tape drive, without affecting server operation. Allow up to 2 minutes for the entire tape drive process to complete.

Attention: Resetting a tape drive before the current backup operation has completed can cause loss of customer data.

To reset the tape drive, complete the following steps:

1. Press and hold the eject button for 20 seconds, and then release the button. The LEDs on the drive flash while the reset function is in process.
2. After the LEDs stop flashing, wait approximately one minute for the drive to complete the reset operation. The drive is then ready to use.

160/320 GB DAT320 USB tape drive (FC 5673)

Learn about the features of this media device.

Table 45. 160/320 GB DAT320 USB tape drive features

Feature	Description
Description	<p>The 160/320 GB DAT320 USB Tape Drive is a 5.25-inch, half-high, USB drive, which provides a high capacity for save/restore and archive functions. To see an illustration of this drive, see Figure 8 on page 78. This tape drive uses IBM DAT320, 4 mm data cartridges and is compression capable, providing a capacity of up to 320 GB with 2:1 compression ratio.</p> <p>Characteristics:</p> <ul style="list-style-type: none"> • Drive part number: 46C1934 • FRU part number: 46C1935 • Custom card identification number (CCIN): 63A0 • Media part numbers: see "Tape cartridges (FC 5673)" on page 80 • Capacity: 160 GB native mode, 320 GB (typical) compression mode • Form factor: 5.25-inch half high • Media: DAT320, DAT160 • Technology: helical scan, rotating head • Operation: streaming • Data transfer rate: 12 MBps native mode • Microcode level: VU10 • Interface: integrated, internal USB with right-angle connector. • Compatibility: DAT160 (read/write) and DAT320 (read/write) <p>Note: DAT160 media is more abrasive than DAT320 media and can be used for occasional use only.</p> <ul style="list-style-type: none"> • Attributes provided: DAT320 tape, test cartridge, and a cleaning cartridge • Attributes required: One 1.6-inch (41 mm) half-high media bay and Feature Code 3657, USB cable with right angle connector.
Tools	<p>The following tools and documentation are needed to complete the installation:</p> <ul style="list-style-type: none"> • A flat-blade screwdriver (if this device is not an auto-docking feature on your system) • Your system unit documentation, including any service documentation • Your operating system documentation <p>Contact the place of purchase if an item is missing or damaged.</p> <p>Note: If you are installing the auto-docking version of this device on your system, see your system documentation for information about the auto-docking feature.</p>

Table 45. 160/320 GB DAT320 USB tape drive features (continued)

Feature	Description
Media	<p>This tape drive uses 4 mm data cartridges for saving and restoring system data. It is designed to use only DDS (Digital Data Storage) data cartridges. The cartridges are identified by one of the following DDS symbols:</p> <div style="text-align: center;">  </div> <p>The tape drive reads and writes data to tape cartridges that are in the DAT160 or DAT320 format.</p>
Related information	<p>Your package contains the following items:</p> <ul style="list-style-type: none"> • The tape drive • Media kit containing: <ul style="list-style-type: none"> – One cleaning cartridge – One test cartridge • Specific hardware for attaching the drive to your specific system, as detailed on the parts listing provided with your drive.

Cleaning the tape drive (FC 5673)

You will need to clean your tape drive. Use the procedure in this topic to perform this task.

Clean the device whenever the Fault status light comes on or a system I/O error related to the device occurs.

Attention: Use only the recommended cleaning cartridge to clean the tape drive. Use of other than recommended cleaning cartridge damages your drive and voids the warranty. The cleaning cartridge for this drive is P/N 35L2086 and it is the only cleaning cartridge that can be used in this drive.

The tape drive will turn on the cleaning indicator for the following reasons:

- The tape drive exceeds internal preset error thresholds in the drive.
- A cleaning cartridge that has been used the maximum number of times is inserted in the drive. The cleaning indicator is turned on to indicate that the cleaning process was not done and the cleaning cartridge is no longer usable.
- The tape drive exceeds the maximum recommended time between cleaning.

The tape drive determines how much to clean the drive and uses less or more cleaning media depending on what the drive determines is necessary. The average number of uses expected from a cleaning cartridge is 50, the minimum is 27, and the maximum is 70.

The maximum recommended time between preventive-maintenance cleaning is 50 tape motion hours. Tape motion hours are defined as the time that the tape drive is moving tape. If the tape drive reaches 50 tape motion hours since the tape drive was last cleaned, the drive turns on the cleaning required LED to indicate the drive needs cleaning. The tape drive will continue to operate but the tape drive must be cleaned at the next opportunity to insert a cleaning cartridge.

Note: Operating the tape drive in a low-humidity environment causes the drive to request cleaning more often than in normal humidity environment. In extreme low-humidity conditions of less than 15% relative humidity, the tape drive might request cleaning every 10 tape motion hours or even more frequently. For this reason, it is best not to use the tape drive in extremely low-humidity environments.

To clean the tape drive, complete the following steps:

1. Make sure that the power is on for the tape drive.
2. If a tape cartridge is in the tape drive, eject and remove the cartridge.
3. Grasp the cleaning cartridge by the outer edges, with the window-side up and the write-protect switch facing you.
4. Slide the cartridge into the opening on the front of the drive until the loading mechanism pulls the cartridge into the drive and the drive door closes.

After the cleaning cartridge has been inserted, the remainder of the cleaning process is automatic. The tape drive does the following actions:

- Loads the cleaning cartridge into the tape drive.
- Cleans the drive by moving the cleaning tape forward for approximately 30 seconds.
- Unloads the cleaning cartridge when the cleaning operation is complete.
- Indicates a successful cleaning operation by turning off the Cleaning status light (if the Cleaning light was on prior to the cleaning process. Otherwise, the Cleaning light remains solid to indicate that the cleaning cartridge is no longer usable. Obtain a new cleaning cartridge and repeat the process.)

Note: If the cleaning operation completes but the Cleaning light remains on, repeat the cleaning procedure with a new cleaning cartridge. If the light still remain on, contact your authorized service representative.

If you attempt to use a depleted cleaning cartridge, the drive automatically detects the error and ejects the cartridge. If the Cleaning status light was on prior to the cleaning process, it stays on; if the Cleaning light was off, the depleted cartridge causes the light to come on.

If a system error occurs, clean the drive and retry the operation. If the operation fails, replace the data cartridge, clean the drive again, then retry the operation.

Loading and unloading tape cartridges

Learn about loading and unloading tape cartridges from this drive.

To avoid problems with loading and unloading tape cartridges use only one label on a cartridge. If the tape cartridge has too many labels or poorly placed labels, the drive-load mechanism might clog.

Loading a tape cartridge:

To load a tape cartridge, complete the following steps:

1. Make sure that the tape device power is on.
2. Grasp the tape cartridge by the outer edges, with the window side up and the write-protect switch facing you.

Note: Make sure that the write-protect switch is correctly set.

3. Slide the tape cartridge into the opening on the front of the device until the loading mechanism pulls the tape cartridge into the drive and the drive door closes.

To indicate that the load operation was successful, the ready status light comes on.

Unloading a tape cartridge:

To unload a tape cartridge, complete the following steps:

1. Make sure that the tape device power is on.
2. Press the Unload button. The device rewinds, unloads, and ejects the tape cartridge.

The process might take from 15 seconds to several minutes, depending on the position of the tape and the amount of data written. During this task, the status lights do the following sequence:

- The ready status light turns off.
- The activity status light flashes during the unload operation.
- The activity status light turns off when the cartridge is ejected from the tape drive.

Attention: An emergency eject and reset feature can be used to release the tape cartridge and to reset the drive. Use the emergency eject feature if the cartridge does not move correctly or if the unload process fails. The emergency eject and reset feature procedure might result in loss of data. To perform an emergency eject operation of the tape cartridge or a reset operation of the drive, press and hold the Unload button for at least 10 seconds. If a cartridge is in the drive, the cartridge automatically ejects without rewinding the tape.

Setting the write-protect switch

You might need to set the write-protect switch on the media. Use the information in this topic to perform this task.

Attention: Do not attempt to change the write-protect settings after the tape cartridge is loaded in the drive because this might cause unpredictable results and might damage the tape or the drive.

The position of the write-protect switch on the tape cartridge determines when you can write to the tape.

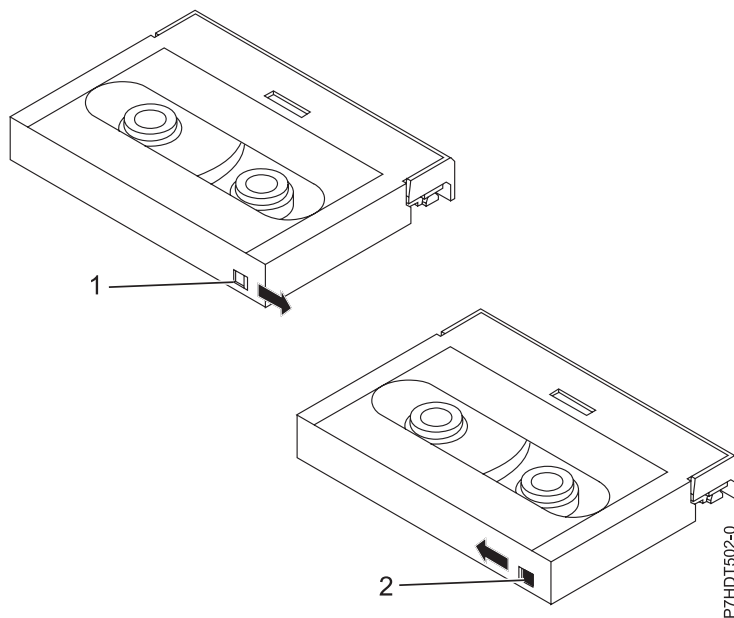

Table 46. Index number and the corresponding description of the tape cartridge

Index number	Description
1	When the switch is set to the right, data can be written to and read from the tape.
2	When the switch is set to the left, data can only be read.

Status lights (FC 5673)

You might need to read the status lights on your tape drive to determine the operating status of the drive. Use the information in this topic to perform this task.

The following illustration is a front view of the tape drive:

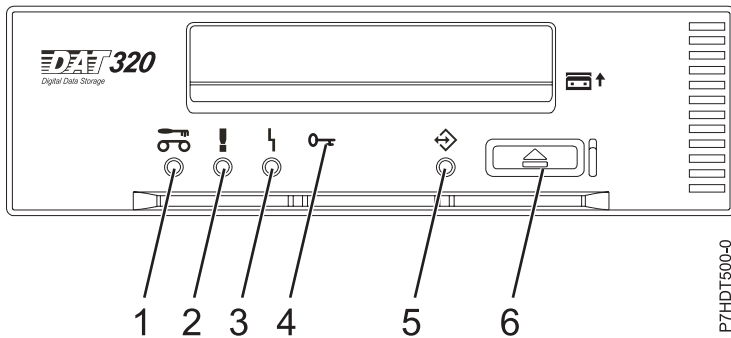

Figure 8. Front view of tape drive

Table 47. Index number and the corresponding description for the front view of the drive

Index number	Description
1	Cleaning LED (amber)
2	Media fault LED (amber)
3	Drive fault LED (amber)
4	Encrypt LED (blue)
5	Ready/Activity LED (green)
6	Unload/Reset button

The combinations of the lights and their definitions are shown in the following table.

Table 48. Definition of status light combinations

Activity	Cleaning (amber) 	Tape fault (amber) 	Drive fault (amber) 	Encrypt fault (blue) 	Ready/ Activity (green)
Power on LED test (5 seconds)	On	On	On	On	On
Power on self-test (POST) activity	Off	Off	Off	Off	Flash_2Hz
POST failed	Off	Off	Flash_2Hz	Off	Off
POST passed	On ¹ or off	Off	Off	Off	Off
Data cartridge					
Loading	On ¹ or off	Off	Off ⁸	Off	Flash_2Hz
Loaded, no activity	On ¹ or off	On ² or off	Flash_2Hz ⁴ or off	Off	On
Loaded, activity	On ¹ or off	On ² or off	Flash_2Hz ⁴ or off	Off	Flash_2Hz
Unloading	On ¹ or off	On ² or off	Flash_2Hz ⁴ or off	Off	Flash_2Hz
Ejected	On ¹ or off	On ² or off	Flash_2Hz ⁴ or off	Off	Off
Cleaning cartridge					
Loading, cleaning, unloading	On	Off	Flash_2Hz ⁴ or off	Off	Flash_2Hz

Table 48. Definition of status light combinations (continued)











Activity	Cleaning (amber) 	Tape fault (amber) 	Drive fault (amber) 	Encrypt fault (blue) 	Ready/ Activity (green) 	
Ejected, clean success	Off	Off	Flash_2Hz ⁴ or off	Off	Off	
Ejected, clean failure	On ¹	On ³	Flash_2Hz ⁴ or off	Off	Off	
Unrecoverable media failure	On	On	Off	Off	Flash_2Hz or on or off	
Firmware download						
Unload (if cartridge present)	See: Data Cartridge Unloading					
Download and reprogram	Flash_8Hz	Off	Off	Off	Flash_8Hz	
Reset (5 seconds)	On	On	On	Off	On	
Self-tests	See Power on self-test activity, and then see either POST passed or POST failed.					
Firmware download fail ⁵ Note: This is cleared when other activity occurs ¹⁰	Off	Off	Flash_2Hz	Off	Off	
Diagnostic tape test						
Eject initiated primed drive to treat inserted data cartridge as diagnostic tape	Normal	Normal	Normal	Off	Flash_4Hz	
Initiated by SCSI diagnostic using normal data tape	In progress	See Data cartridge: Loaded, activity				
	Passed ⁷	See Data cartridge: Loaded, no activity				
	Failed ⁶	On	On	On	Normal	Flash_4Hz
	Until tape ejected. See Data cartridge: ejected					
Using tape with diagnostic tape recognition holes	In progress	See Data cartridge: loading				
		Flash_4Hz	Off	Off	Normal	Flash_4Hz
	Passed ⁹ , tape ejected	Off	Off	Off	Normal	Flash_4Hz
		See Data cartridge: ejected				
	Failed ⁶	On	On	On	Normal	Flash_4Hz
See Data cartridge: ejected						
Encryption related¹¹						
No encryption or decryption activity	Normal	Normal	Normal	Off	Normal	
Encryption parameters are loaded; the drive is ready to read/write encrypted data	Normal	Normal	Normal	On	Normal	
Drive is reading/writing encrypted data	Normal	Normal	Normal	Flash_2Hz	Flash_2Hz	
Encryption parameters loaded, but the drive is reading/writing unencrypted data.	Normal	Normal	Normal	On	Flash_2Hz	
Encryption related error exists	Normal	Normal	Flash_4Hz	Flash_4Hz	Normal	

Table 48. Definition of status light combinations (continued)

Activity	Cleaning (amber) 	Tape fault (amber) 	Drive fault (amber) 	Encrypt fault (blue) 	Ready/ Activity (green) 
<p>¹ CLEAN_LED activation in this state means the drive needs cleaning. It will be set due to hard or soft errors. It is cleared upon successful cleaning cartridge usage. State is preserved over a power cycle.</p> <p>² TAPE_LED activation in this state can only be due to a repeated hard or soft error. It is cleared when data or cleaning cartridge is inserted.</p> <p>³ TAPE_LED activation in this state can only be due to a cleaning cartridge failure. It is cleared when data or cleaning cartridge is inserted.</p> <p>⁴ DRIVE_LED activation in this state can only be due to the media management algorithm determining that the drive has a serious problem with regard to its write/read performance. It is not preserved over power cycle.</p> <p>⁵ The firmware download failed. The firmware download should be retried. Note: This does not happen if the problem is simply due to an incorrect firmware image being attempted, for example, the DAT72 image being downloaded to DAT160. The purpose of this LED sequence is to show the user that the download failed and to retry the download. Examples of this are if the host failed to send all the data or if the hardware was unable to complete the task. This sequence is not activated if the microcode headers are invalid or if the code fails its checksum.</p> <p>⁶ The LED states for SCSI/tape diagnostic failed remain until the ejection is completed and then either the Eject button is pressed or another tape is inserted.</p> <p>⁷ The LEDs revert to nondiagnostic tape state (for example, for a loaded data tape).</p> <p>⁸ If the drive LED is on, the tape load is not initiated.</p> <p>⁹ The LED states for tape diagnostic passed remain until the auto-eject operation is completed.</p> <p>¹⁰ The firmware download failed LEDs continue to show until another change to the LEDs is required that is due to either cartridge loading or unloading or due to tape motion. So it is not SCSI commands, as such, that clear this but the response of the LED display to those SCSI commands. Tape access commands cause cartridge or tape motion to occur.</p> <p>¹¹ IBM does not support encryption in their systems, but the LED activity is included in the event that a user inserts a tape with encrypted data.</p>					

Tape cartridges (FC 5673)

Learn about the types of tape cartridges that are available for this drive.

Available tape cartridges

Table 49. 4 mm data cartridges

IBM part number	Type of cartridge
46C1936	DAT320 160 GB Data Cartridge
46C1938	4 mm Test Cartridge
46C1937	4 mm Cleaning Cartridge (Only use on the DAT320 tape drive)

Most bulk eraser devices do not have the capability to erase the 4 mm data cartridge.

Resetting the tape drive

You might need to reset your tape drive. Use the procedure in this topic to perform this task.

Use this information to reset your tape drive, without affecting server operation. Allow up to 2 minutes for the entire tape drive process to complete.

Attention: Resetting a tape drive before the current backup operation has completed can cause loss of customer data.

To reset the tape drive, complete the following steps:

1. Press and hold the eject button for 20 seconds, and then release the button. The LEDs on the drive flash while the reset function is in process.
2. After the LEDs stop flashing, wait approximately one minute for the drive to complete the reset operation. The drive is then ready to use.

Managing DVD drives

Learn about using and managing removable media devices. Find specifications and installation notes for specific drives.

SATA Slimline DVD-ROM Drive (FC 5743)

Learn about the specifications of this DVD-ROM drive.

The serial advanced technology attachment (SATA) Slimline DVD-ROM Drive is an internal tray loading DVD-ROM drive. It is a 12.7 mm slimline form factor DVD-ROM drive that is capable of multiple sessions. This drive also reads type II (removable from cartridge) DVD-RAM discs. System boot and installation functions are supported with CD-ROM, DVD-ROM, and DVD-RAM media.

Specifications

- FRU part number: 44V4224
- Custom card identification number (CCIN): 6337 model 004
- Media: reads CD-ROM, CD-R, CD-RW, DVD-ROM, and DVD-RAM discs
- Interface: SATA
- Connector: Slimline SATA
- Form factor: 12.7 mm Slimline
- Loading tray: supports 12 cm and 8 cm discs
- Operating positions: vertical or horizontal (8 cm discs require horizontal operation)
- Interface: uses standard and extended XA formats
- DVD video: not supported
- AIX 5.1 only reads CD-type formatted DVD media
- Requirements: 1 Slimline media bay

Related reference:

“Opening a DVD tray manually” on page 83

Under usual conditions, the tray automatically opens when you press the Load/Unload button. If it does not automatically open, you can use the emergency eject feature to open the tray manually.

“DVD-RAM type II disc” on page 83

The DVD-RAM type II disc can be removed from its cartridge and played in a DVD-ROM or DVD-RAM drive that is compatible with the DVD-RAM type II disc.

SATA Slimline DVD-RAM Drive (FC 5762)

Learn about the specifications of this DVD-RAM drive.

The serial advanced technology attachment (SATA) Slimline DVD-RAM Drive is an internal, low profile DVD-RAM drive that is capable of reading and writing 4.7 GB DVD-RAM discs, as well as reading a

multitude of other optical media discs. This drive also reads type II (removable from cartridge) DVD-RAM discs. System boot and installation functions are supported with CD-ROM and DVD-RAM media.

Specifications

- FRU part number: 44V4220
- Custom card identification number (CCIN): 6331 model 004
- Media:
 - Reads CD-ROM, CD-R, CD-RW, DVD-ROM, and DVD-RAM discs
 - Writes 4.7 GB DVD-RAM discs
- Interface: SATA
- Connector: Slimline SATA
- Connector: SATA
- Loading tray: supports 12 cm and 8 cm discs
- Operating positions: vertical or horizontal (8 cm discs require horizontal operation)
- Form factor: 12.7 mm Slimline
- DVD video: not supported
- AIX 5.1 only reads CD-type formatted DVD media
- Requirements: 1 Slimline media bay

Related reference:

“Opening a DVD tray manually” on page 83

Under usual conditions, the tray automatically opens when you press the Load/Unload button. If it does not automatically open, you can use the emergency eject feature to open the tray manually.

“DVD-RAM type II disc” on page 83

The DVD-RAM type II disc can be removed from its cartridge and played in a DVD-ROM or DVD-RAM drive that is compatible with the DVD-RAM type II disc.

SATA Slimline DVD-RAM Drive (FC 5771)

Learn about the specifications of this DVD-RAM drive.

The serial advanced technology attachment (SATA) Slimline DVD-RAM Drive is an internal, low profile DVD-RAM drive that is capable of reading and writing 4.7 GB DVD-RAM discs, as well as reading a multitude of other optical media discs. This drive also reads type II (removable from cartridge) DVD-RAM discs. System boot and installation functions are supported with CD-ROM and DVD-RAM media.

Specifications

- FRU part number: 74Y7341
- Custom card identification number (CCIN): 6331 model 004
- Media:
 - Reads CD-ROM, CD-R, CD-RW, DVD-ROM, and DVD-RAM discs
 - Writes 4.7 GB DVD-RAM discs
- Interface: SATA
- Connector: Slimline SATA
- Connector: SATA
- Loading tray: supports 12 cm and 8 cm discs
- Operating positions: vertical or horizontal (8 cm discs require horizontal operation)
- Form factor: 12.7 mm Slimline

- DVD video: not supported
- AIX 5.1 only reads CD-type formatted DVD media
- Requirements: 1 Slimline media bay

Handling and storing the DVD media

Learn how to handle and store the DVD media.

DVD media must be handled with care. Leaving the media exposed allows dirt particles to accumulate and to become a source of contamination. Handling the DVD media with care reduces errors and improves the performance.

Restrictions on using DVD media

Correct ways to handle DVD media:

1. Handle media by the outer edge or the center hole.
2. Store media in jewel cases specified for DVDs.
3. Return media to storage cases immediately after use to minimize the effects of environmental changes.
4. Store media in a cool, dry environment in which the air is clean.
5. Remove dirt, foreign materials, fingerprints, smudges, and liquids by wiping with a clean cotton fabric in a straight line from the center of the disc toward the outer edge.
6. Check the media surface before recording.

Incorrect ways to handle DVD media:

1. Touch the surface of the media.
2. Bend the media.
3. Use adhesive labels on the media.
4. Expose media to extreme heat or high humidity.
5. Expose media to prolonged sunlight or other sources of ultraviolet light.
6. Write or mark in the data area of the media.
7. Clean by wiping in a circular direction going around the disc.

Opening a DVD tray manually

Under usual conditions, the tray automatically opens when you press the Load/Unload button. If it does not automatically open, you can use the emergency eject feature to open the tray manually.

Follow these steps to manually open the tray:

1. Follow your operating system instructions for shutting down your system, then turn off the power to your system unit. Unplug the power cord from the wall outlet.
2. Insert the straightened end of a paper clip into the emergency eject hole until you feel some resistance.
3. Continue to push in the paper clip while you pull out the tray with your fingernail.
4. Pull the tray completely open and remove the disc. It is usual for the tray to make a clicking sound while you are pulling it open.

DVD-RAM type II disc

The DVD-RAM type II disc can be removed from its cartridge and played in a DVD-ROM or DVD-RAM drive that is compatible with the DVD-RAM type II disc.

Attention: Be careful when handling removed discs. Debris, dust particles, fingerprints, smears, or scratches can affect recording and playback of discs. Do not use solvents to clean disc surfaces. To clean a disc, use a soft, lint free cloth and gently wipe the disc surface outwards from the center hole to the outer edge. Do not rub, make circular motions or try to follow the circular lines in the disc. When labeling a disc, write only on the printed label side, using a soft felt-tip marker. Do not use a hard-tip pen to write on disc surface. Keep out of direct sunlight, high temperatures, and humidity. Do not attach labels to either side of the disc.

Removing a disc from the cartridge

To remove a disc from the cartridge, do the following steps:

Note: Handle the disc only by its edges.

1. Use the tip of a ballpoint pen to push the locking pin up and out of the disc cartridge.
2. Use the tip of a ballpoint pen to push down on the lock button while pulling the cartridge lid open.
3. With the cartridge lid open, slide the disc out of the cartridge.

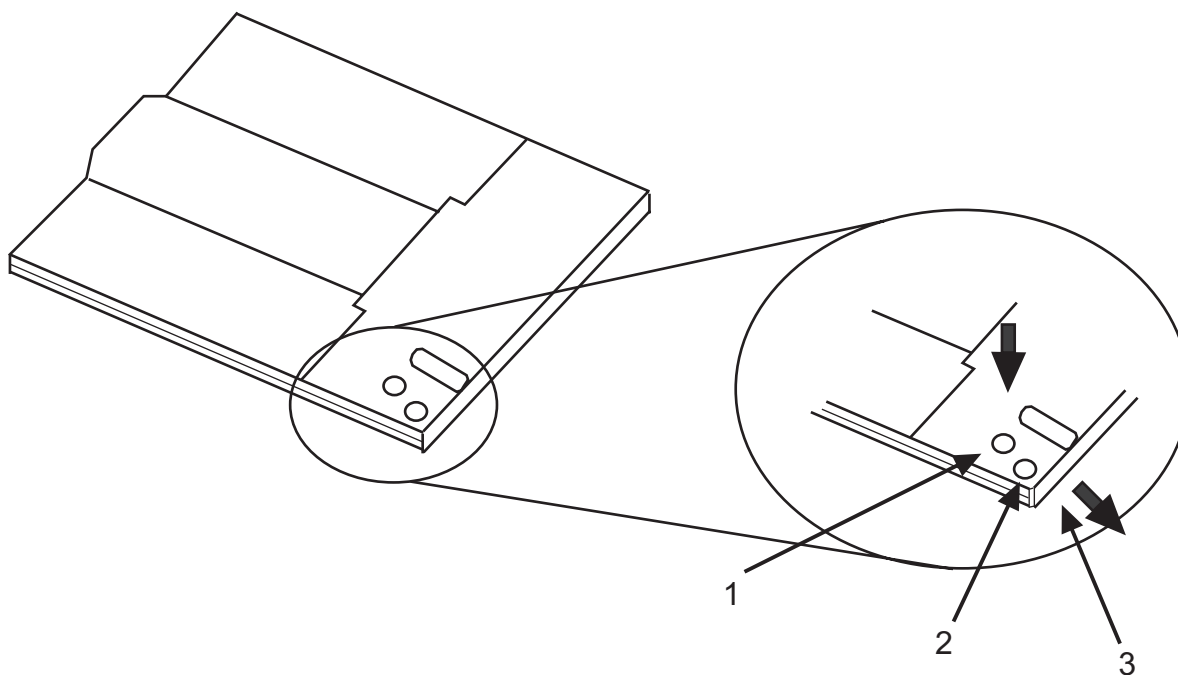

Table 50. Index number and corresponding description for removing a disc from the cartridge

Index number	Description
1	Locking Pin
2	Lock Button
3	Cartridge Lid

Returning a disc to the cartridge

To return a disc to the cartridge, do the following steps:

Notes: Both the disc label and the cartridge label should be facing up. Handle the disc only by its edges.

1. Slide the disc into the cartridge.
2. Close the cartridge lid. Make sure the lock button snaps into position.
3. Install the locking pin.

Managing diskette drives

Learn about the features of specific diskette drives.

External USB 1.44 MB diskette drive (FC 2591)

Learn about the features of this media device.

The following provides information about the external USB 1.44 MB diskette drive.

Table 51. External USB 1.44 MB diskette drive features

Feature	Description
Installation and removal	<p>To install this external USB 1.44 MB diskette drive, complete the following steps:</p> <ol style="list-style-type: none"> 1. Unpack the device and ensure you have all the cables and parts. 2. Connect the USB cables to an available USB port on the system unit. 3. Wait for the system to recognize the new device (approximately 1-3 minutes). <p>To remove this external USB 1.44 MB diskette drive, complete the following steps:</p> <ol style="list-style-type: none"> 1. Ensure you complete any processes running from or to the diskette drive. 2. Eject any diskette you have in the device. 3. Disconnect the device from the system unit. <p>If you are installing this device on a system or partition running any other operating system, see the documentation for that operating system.</p>
Description	<p>The externally attached USB diskette drive provides storage capacity up to 1.44 MB on a high-density (2HD) diskette and 720 KB on a double-density diskette. Includes 350mm (13.7 in) captured cable with standard USB connector.</p> <p>Limitations:</p> <ul style="list-style-type: none"> • Maximum 1 USB diskette per adapter • Up to 1 Keyboard and Mouse also supported on the adapter with the diskette drive at the same time • No system boot capability • Not to be operated upside down or with eject button down <p>Characteristics:</p> <ul style="list-style-type: none"> • FRU part number: 033P3339 • Capacity - 1.44 MB (2HD disk) or 720 KB (double-density disk) • Physical Dimensions: Width=103mm (4.05 in), Height=17.6mm (.69 in), Depth=141.8-mm (5.58 in) • Color: Black • Data Rate: 12 Mbits/sec • Maximum Power Consumption: 2.36 Watt (seek) • Operates in all positions except those noted in the preceding limitations • Attributes provided: External diskette drive • Attributes required: 1 available USB port

Managing disk devices

Find information about managing disk devices.

To learn about managing disk devices for the AIX operating system, see Logical Volume Manager and `manage_disk_drivers` Command.

To learn about managing disk devices for the Linux operating system, see Linux Logical Volume Manager.

Managing removable disk drives

Learn about using and managing removable disk drives. Find specifications and installation notes for specific drives.

RDX USB Internal Dock (1103, 1123, EU03, and EU23) and RDX Removable Disk Drives (1106, 1107, EU01, EU08 and EU15)

Learn about the features of this drive.

Description

The feature code (FC) 1123 and FC EU23 information applies only to an 8231-E2B, 8231-E1C, 8231-E1D, 8231-E2C, 8231-E2D, or 8268-E1D system.

The FC 1103 and FC EU03 information applies only to an 8202-E4B, 8202-E4C, 8202-E4D, 8205-E6B, 8205-E6C, or 8205-E6D system.

The USB Removable Disk Drive consists of a docking station, which holds a removable disk drive. The docking station is available as an internal or external device. The disk drive is a backup and restore device that can be used as an alternative to tape drives. The removable disk drive is not a replacement for regular disk drives and cannot be used as part of a disk array. The following illustrations show the internal drives.

Figure 9. Internal drive, front view

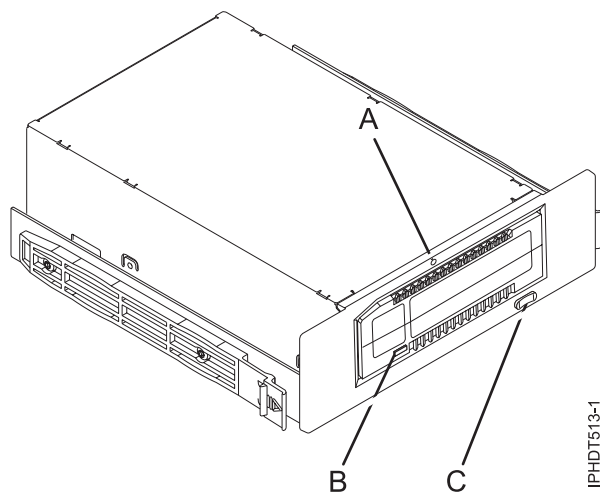

- A Emergency eject hole
- B Cartridge indicator light
- C Eject button and power indicator light

Figure 10. Rear view and connectors on the internal drive

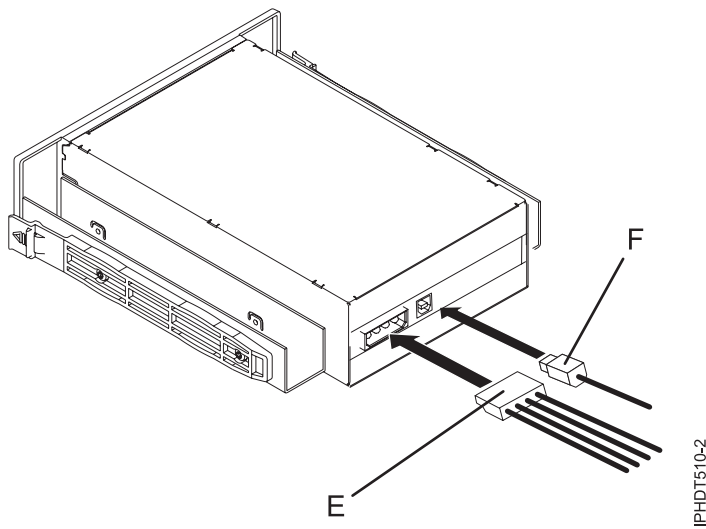

E Power connector

F USB connector

Feature codes and part numbers

Learn about the feature codes (FCs) and part numbers for the USB Removable Disk Drive.

FC 1103 - USB Internal Docking Station for Removable Disk Drive

FC 1103 uses an internal USB cable to connect to the internal USB media device connector on the system backplane of a system that supports this feature. The internal USB media device cable and power cable are included in the feature code.

FC 1103 provides the following parts:

- 46C5370 (FRU: 46C5380) - USB Internal docking station
- 46K7435 - Internal USB media device cable (12 inch)
- 46K7434 - Internal power cable (11 inch) with right angle power connector
- 44V3429 - Two drive slide assembly rails
- 1621187 - Four flat blade screws

FC 1123 - USB Internal Docking Station for Removable Disk Drive

FC 1123 uses an internal USB cable to connect to the internal USB media device connector on the system backplane of a system that supports this feature. The internal USB media device cable and power cable are included in the feature code.

FC 1123 provides the following parts:

- 46C2425 (FRU: 46C2217) - Internal 3.5" RDX USB Dock
- 46K5031 - Internal USB media device cable (12 inch)
- 46K5032 - Internal power cable (11 inch)

Requires FC 5263

DASD/Media Backplane - 3 SFF DASD/SATA DVD/HHTape. The FC 5263 is supported on the 8231-E2B system.

Note: A single mounting clip (74Y5182) is provided with the system and is not part of this FC 5263.

FC EU03 - USB Internal Docking Station for Removable Disk Drive

FC EU03 uses an internal USB cable to connect to the internal USB media device connector on the system backplane of a system that supports this feature. The internal USB media device cable and power cable are included in the feature code.

FC EU03 provides the following parts:

- 46C2332 (FRU: 46C2346) - Internal RDX USB 3.0 Dock
- 46K7435 - Internal USB media device cable (12 inch)
- 46K7434 - Internal power cable (11 inch) with right angle power connector
- 44V3429 - Two drive slide assembly rails
- 1621187 - Four flat blade screws

FC EU23 - USB Internal Docking Station for Removable Disk Drive

FC EU23 uses an internal USB cable to connect to the internal USB media device connector on the system backplane of a system that supports this feature. The internal USB media device cable and power cable are included in the feature code.

Note: The FC EU23 is not supported on IBMi systems, because IBMi does not support the split backplane on the systems that support FC EU23.

FC EU23 provides the following parts:

- 46C2443 (FRU: 46C2444) - Internal 3.5" RDX USB 3.0 Dock
- 46K7435 - Internal USB media device cable (12 inch)
- 46K7434 - Internal power cable (11 inch) with right angle power connector

Requires FC 5263

DASD/Media Backplane - 3 SFF DASD/SATA DVD/HHTape. The FC 5263 is supported on the 8231-E2B system.

Note: A single mounting clip (74Y5182) is provided with the system and is not part of this FC 5263.

Removable disk drives

Table 52. Removable disk drives

Feature code	Part number	Description
1106	46C5375	160 GB Removable Disk Drive
1107	46C5379	500 GB Removable Disk Drive
EU01	46C2335	1 TB Removable Disk Drive
EU08	46C5377	320 GB Removable Disk Drive
EU15	46C2831	1.5 TB Removable Disk Drive

Purchasing additional removable disk drives

For best results, use only the removable disk drives that are shown in Table 52.

The removable disk drives are a supply item that can be ordered as a feature code. To order in the United States and Canada, call 1-888-IBM-MEDIA. To order drives in other locations, contact your local provider of IBM storage products or see Storage Media (<http://www.storage.ibm.com/media/>).

The removable disk drives are not a service item. IBM service representatives are not dispatched to service or replace the removable disk drives.

Storing removable disk drives

Store removable disk drives in their protective containers, on a flat surface with the top side up. The storage area must be clean and dry, must have normal room temperature, and must be away from any magnetic fields. For best storage life, use the removable disk drives every six months.

Supported USB adapters and cables

Attention: The docking station only supports the USB cable that is provided as part of the feature code. The docking station does not support attachment by using USB hubs, add-on USB cables, or USB cable extenders.

The internal docking station can be connected to the internal USB media device connector on the system backplane of POWER7[®] processor-based systems.

Note: When the internal USB media device port on the system backplane is used for the docking station, the port is disabled for any other use. This information does not apply to an 8231-E2B, 8231-E1C, 8231-E1D, 8231-E2C, 8231-E2D, or 8268-E1D system.

Specifications

Interface

USB 2.0

Mksysb

Yes

Bootable

Yes

Physical form factor (internal docking station)

5.25 inch half high

3.5 inch half high for an 8231-E2B, 8231-E1C, 8231-E1D, 8231-E2C, 8231-E2D, or 8268-E1D system (FC 1123)

Environmental

USB Removable Disk Drive	Operating conditions	Non-operating conditions
Temperature	5°C to 55°C	-40°C to 65°C
Relative humidity	8 - 90% noncondensing	5 - 95% noncondensing
Maximum wet bulb temperature	29.4°C noncondensing	40°C noncondensing
Maximum temperature gradient	20°C per hour	20°C per hour
Altitude	-300 m to 3048 m (10,000 ft)	-300 m to 12,192 m (40,000 ft)

Supported operating systems

USB Removable Disk Drive is supported on the following versions of operating systems:

- AIX 5L Version 5.3 with the 5300-11 Technology Level, or later
- IBM i 7.1 with the Technology Refresh PTF Group Level 5, or later
- AIX Version 6.1 with the 6100-04 Technology Level, or later
- Red Hat Enterprise Linux version 3 Update 7, or later
- SUSE Linux Enterprise Server 10, or later

Using the USB Removable Disk Drive for backup and restore

The disk drive is a backup and restore device that can be used as an alternative to tape drives. The removable disk drive is not a replacement for regular disk drives and cannot be used as part of a disk array.

Note: If power is lost during a backup to the disk, the data can be compromised. Verify the data or rerun the backup.

Using the drive with AIX

AIX names the drive `usbmsx`, for example, `usbms1`, and `usbms2`. AIX also can use the device as a raw device, for example, `rusbms1` and `rusbms2`.

AIX uses the removable disk drive differently depending on the program being used. The AIX `mksysb` command builds a list of files to back up, creates a universal disk format (UDF) file system, and puts a boot image and the root volume group on the removable disk drive. When the `mksysb` process is complete the removable disk drive can be used to boot the system. If you mount the removable disk drive, you can display and copy files to and from the UDF file system on the removable disk drive.

The AIX `tar`, `backup`, `restore`, `dd`, and `cpio` commands can write to the removable disk drive as a raw device or nonraw device. You might get improved performance by using the device as a raw device.

See the AIX documentation for additional information.

Using the drive with IBM i

IBM i configures the drive as a removable media drive with a name in the format `RMSxx`, for example, `RMS01`.

The drive and cartridge are used with optical commands and utilities (for example, `WRKOPTVOL` and `INZOPT`), and reports media in the `QOPT` file system.

See the IBM i documentation for information about using IBM i copy and backup commands.

Using the drive with Linux

Linux configures the drive as a disk drive with a name in the format `sdx`, for example, `sda`, `sdb`, and `sdc`.

See the Linux documentation for information about using Linux copy and backup commands.

Setting the write-protect switch

The removable disk drives have a red, write-protect tab that is located on the back of the drive. To write-protect a drive, slide the write-protect tab toward the lock symbol. To disengage write protection, slide the tab to the unlock symbol.

Using the emergency eject function

To eject a removable disk drive, press the eject button. If a drive is stuck, complete the following steps:

1. If you are using the internal docking station, power off the system. If you are using the external docking station, unplug the power cable from the device.
2. Insert a large straightened paper clip (or similar object) into the emergency eject hole. Do not insert the object in the hole at an angle. Keep the object straight and apply some force to eject the drive.

- When the drive has been ejected by the docking station, grasp the exposed sides of the drive and pull the drive straight out.
- Restart your system to reset the docking station. If you are using the external docking station, reconnect the power cable for the docking station and then restart the system.

Status lights

yea

Learn about the power indicator and drive indicator status lights on the USB Removable Disk Drive.

Power indicator

The eject button is illuminated by a power indicator light. The following table describes the operation of the power indicator.

Table 53. Power indicator

Indicator status	Meaning	Description
Off	No power	Docking station does not have power.
Steady green	Ready	Power is on and the docking station is working correctly.
Flashing green	Ejecting	Cartridge is ejecting.
Flashing amber	Fault	Docking station has detected a fault condition with the docking station.

Removable disk drive indicator

The disk drive has an indicator light that displays the status of the drive. The following table describes the operation of the drive indicator.

Table 54. Cartridge indicator

Indicator status	Meaning	Description
Off	Not ready	Drive is not inserted correctly or the docking station has no power.
Steady green	Ready	Drive is ready.
Flashing green	Activity	Drive is reading, writing, or seeking.
Flashing amber	Fault	Docking station has detected a fault condition with the cartridge.

RDX USB External Dock (1104 and EU04) and RDX Removable Disk Drives (1106, 1107, EU01, EU08, and EU15)

Learn about the features of this drive.

Description

The USB removable disk drive consists of a docking station, which holds a removable disk drive. The docking station is available as an external device. The disk drive is a backup and restore device that can be used as an alternative to tape drives. The removable disk drive is not a replacement for regular disk drives and cannot be used as part of a disk array. The following illustrations show the external drives.

Figure 11. Front view and external drive with removable disk drive

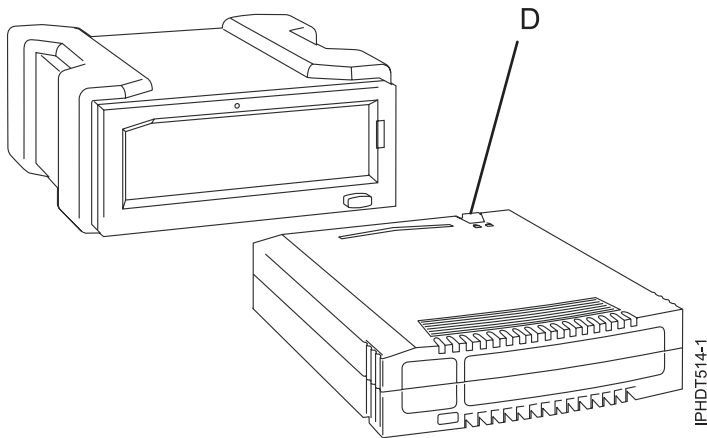

D Write-protect switch

Figure 12. Rear view and connectors on the external drive

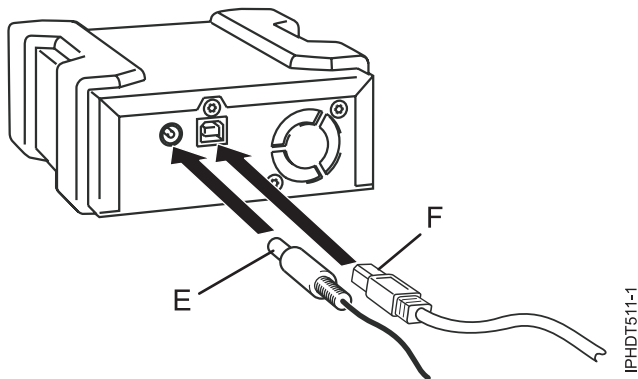

E Power connector

F USB connector

Feature codes and part numbers

Learn about the feature codes (FCs) and part numbers for the USB Removable Disk Drive.

FC 1104 - USB External Docking Station for Removable Disk Drive

FC 1104 uses an external USB cable to connect to an external USB port. The 1104 feature code includes a USB cable, an external power supply, and a power cord as part of the feature code.

FC 1104 provides the following parts:

46C5381 - USB external docking station

44E8889 - External USB cable

49Y9890 - External power supply with power cord and universal plugs for all supported geographies

39M5516 - Power cord (1 m) that connects the power supply to the rack power distribution unit

FC EU04 - USB External Docking Station for Removable Disk Drive

FC EU04 uses an external USB cable to connect to an external USB port. The EU04 feature code includes a USB cable, an external power supply, and a power cord as part of the feature code.

FC EU04 provides the following parts:

46C2333 (FRU: 46C2347) - External RDX USB 3.0 Dock

05H5081 (FRU: 05H5080) - External USB 3.0 Cable (2.7 m or 8'10")

81Y3649 (FRU: 81Y8905) - External power supply with power cord and universal plugs for all supported geographies

39M5516 (FRU: 39M5516) - Power cord (1 m) that connects the power supply to the rack power distribution unit

Removable disk drives

Table 55. Removable disk drives

Feature code	Part number	Description
1106	46C5375	160 GB Removable Disk Drive
EU08	46C5377	320 GB Removable Disk Drive
1107	46C5379	500 GB Removable Disk Drive
EU01	46C2335	1 TB Removable Disk Drive
EU15	46C2831	1.5 TB Removable Disk Drive

Purchasing additional removable disk drives

For best results, use only the removable disk drives that are shown in Table 55.

The removable disk drives are a supply item that can be ordered as a feature code. To order in the United States and Canada, call 1-888-IBM-MEDIA. To order drives in other locations, contact your local provider of IBM storage products or see Storage Media (<http://www.storage.ibm.com/media/>).

Note:

The removable disk drives are not a service item. IBM service representatives are not dispatched to service or replace the removable disk drives.

Storing removable disk drives

Store removable disk drives in their protective containers, on a flat surface with the top side up. The storage area must be clean and dry, must have normal room temperature, and must be away from any magnetic fields. For best storage life, use the removable disk drives every six months.

Supported USB adapters and cables

Attention: The docking station only supports the USB cable that is provided as part of the feature code. The docking station does not support attachment by using USB hubs, add-on USB cables, or USB cable extenders.

The external docking station can be connected to the external, integrated USB ports on POWER7 processor-based systems or can be connected to the USB ports on 4-Port USB PCI Express Adapter (FC 2728).

The internal docking station can be connected to the internal USB port on the control panel of POWER7 processor-based systems.

Note: When the USB port on the control panel is used for the docking station, the port is disabled for any other use. This information does not apply to an 8231-E2B, 8231-E1C, 8231-E1D, 8231-E2C, 8231-E2D, or 8268-E1D system.

Note:

Specifications

Interface

USB 2.0

Mksysb

Yes

Bootable

Yes

Physical form factor (internal docking station)

5.25 inch half high

Environmental

Table 56. Operation conditions

USB Removable Disk Drive	Operating conditions	Non-operating conditions
Temperature	5 -55 C	-40 -65 C
Relative humidity	8 - 90% noncondensing	5 - 95% noncondensing
Maximum wet bulb temperature	29.4 C noncondensing	40 C noncondensing
Maximum temperature gradient	20 C per hour	20 C per hour
Altitude	-300 to 3048 m (10,000 ft)	-300 to 12,192 m (40,000 ft)

Supported operating systems

USB Removable Disk Drive is supported on the following versions of operating systems:

- AIX 5L Version 5.3 with the 5300-11 Technology Level, or later
- IBM i 7.1 with the Technology Refresh PTF Group Level 5, or later
- AIX Version 6.1 with the 6100-04 Technology Level, or later
- Red Hat Enterprise Linux version 3 Update 7, or later
- SUSE Linux Enterprise Server 10, or later

Using the USB Removable Disk Drive for backup and restore

The disk drive is a backup and restore device that can be used as an alternative to tape drives. The removable disk drive is not a replacement for regular disk drives and cannot be used as part of a disk array.

Note: If power is lost during a backup to the disk, the data can be compromised. Verify the data or rerun the backup.

Using the drive with AIX

AIX names the drive `usbmsx`, for example, `usbms1`, and `usbms2`. AIX also can use the device as a raw device, for example, `rusbms1` and `rusbms2`.

AIX uses the removable disk drive differently depending on the program being used. The AIX `mksysb` command builds a list of files to back up, creates a universal disk format (UDF) file system, and puts a

boot image and the root volume group on the removable disk drive. When the **mksysb** process is complete the removable disk drive can be used to boot the system. If you mount the removable disk drive, you can display and copy files to and from the UDF file system on the removable disk drive.

The AIX **tar**, **backup**, **restore**, **dd**, and **cpio** commands can write to the removable disk drive as a raw device or non raw device. You might get improved performance by using the device as a raw device.

See the AIX documentation for additional information.

Using the drive with IBM i

IBM i configures the drive as a removable media drive with a name in the format RMSxx, for example, RMS01.

The drive and cartridge are used with optical commands and utilities (for example, WRKOPTVOL and INZOPT), and reports media in the QOPT file system.

See the IBM i documentation for information about using IBM i copy and backup commands.

Using the drive with Linux

Linux configures the drive as a disk drive with a name in the format sdx, for example, sda, sdb, and sdc.

See the Linux documentation for information about using Linux copy and backup commands.

Setting the write-protect switch

The removable disk drives have a red, write-protect tab that is located on the back of the drive. To write-protect a drive, slide the write-protect tab toward the lock symbol. To disengage write protection, slide the tab to the unlock symbol.

Using the emergency eject function

To eject a removable disk drive, press the eject button. If a drive is stuck, complete the following steps:

1. If you are using the internal docking station, power off the system. If you are using the external docking station, unplug the power cable from the device.
2. Insert a large straightened paper clip (or similar object) into the emergency eject hole. Do not insert the object in the hole at an angle. Keep the object straight and apply some force to eject the drive.
3. When the drive has been ejected by the docking station, grasp the exposed sides of the drive and pull the drive straight out.
4. Restart your system to reset the docking station. If you are using the external docking station, reconnect the power cable for the docking station and then restart the system.

Status lights

Learn about the power indicator and drive indicator status lights on the USB Removable Disk Drive.

Power indicator

The eject button is illuminated by a power indicator light. The following table describes the operation of the power indicator.

Table 57. Power indicator

Indicator status	Meaning	Description
Off	No power	Docking station does not have power.
Steady green	Ready	Power is on and the docking station is working correctly.
Flashing green	Ejecting	Cartridge is ejecting.
Flashing amber	Fault	Docking station has detected a fault condition with the docking station.

Removable disk drive indicator

The disk drive has an indicator light that displays the status of the drive. The following table describes the operation of the drive indicator.

Table 58. Cartridge indicator

Indicator status	Meaning	Description
Off	Not ready	Drive is not inserted correctly or the docking station has no power.
Steady green	Ready	Drive is ready.
Flashing green	Activity	Drive is reading, writing, or seeking.
Flashing amber	Fault	Docking station has detected a fault condition with the cartridge.

Installing the docking station for the removable disk drive

Keep in mind the following points when you install FC 1104, the USB External Docking Station for Removable Disk Drive:

- A rack shelf is not included with FC 1104.
- The docking station can be rested on a flat surface in a rack or on a table top next to a rack.
- Ensure that the device is on a flat surface, is right-side up, and is not likely to be bumped, dropped, or otherwise damaged or jolted.
- If the docking station is placed by itself on a rack shelf, it will have space on the sides of the device. No filler panels are provided with the docking station.
- If the docking station is placed on a rack shelf, ensure that the docking station has sufficient air flow but that it does not affect the air flow of the other systems in the rack.
- Do not block the fan on the back of the docking station.

RDX SATA Internal Dock (EU07) and RDX Removable Disk Drives (1106, 1107, EU01, EU08, and EU15)

Learn about the features of this drive.

Description

The SATA Removable Disk Drive consists of a docking station, which holds a removable disk drive. The docking station is available as an internal or external device. The disk drive is a backup and restore device that can be used as an alternative to tape drives. The removable disk drive is not a replacement for regular disk drives and cannot be used as part of a disk array. The following illustrations show the internal drives.

Figure 13. Internal drive, front view

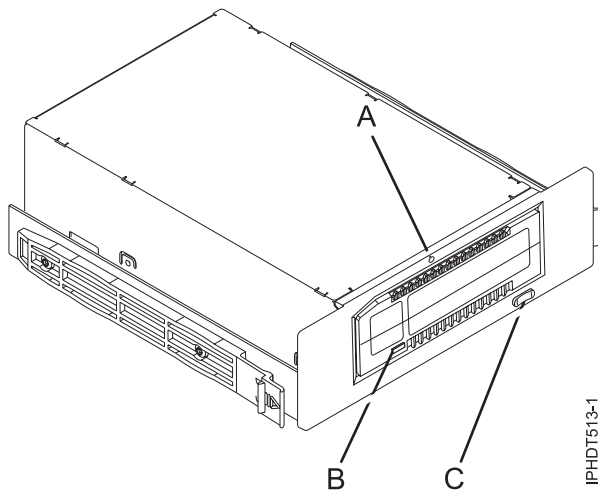

- A Emergency eject hole
- B Cartridge indicator light
- C Eject button and power indicator light

Figure 14. Rear view and connector on the internal drive

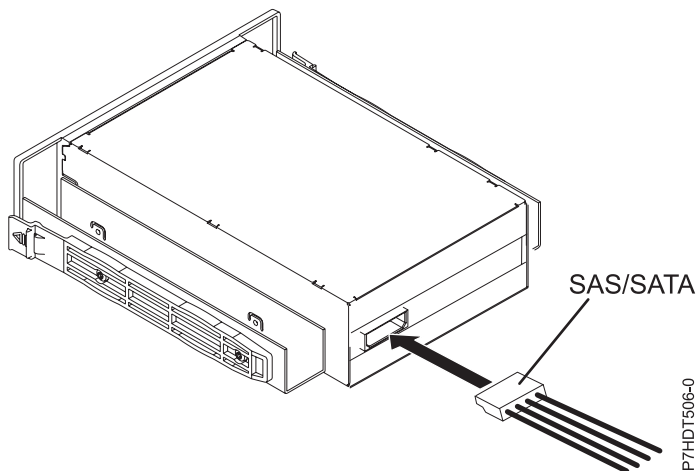

Feature codes and part numbers

Learn about the feature codes (FCs) and part numbers for the SATA Removable Disk Drive.

FC EU07 - SATA Internal Docking Station for Removable Disk Drive

FC EU07 uses an internal SATA cable to connect to the internal SATA port on the control panel of a system that supports this feature. The SATA and power cable are included in the feature code.

FC EU07 provides the following parts:

00E1478 (FRU: 00E1477) - Internal RDX SATA Dock

46K5450 - Internal SAS (logic and power) cable

46K7434 - Internal power cable (11 inch) with right angle power connector

44V3429 - Two drive slide assembly rails

1621187 - Four flat blade screws

Removable disk drives

Table 59. Removable disk drives

Feature code	Part number	Description
1106	46C5375	160 GB Removable Disk Drive
1107	46C5379	500 GB Removable Disk Drive
EU01	46C2335	1 TB Removable Disk Drive
EU08	46C5377	320 GB Removable Disk Drive
EU15	46C2831	1.5 TB Removable Disk Drive

Purchasing additional removable disk drives

For best results, use only the removable disk drives that are shown in Table 59.

The removable disk drives are a supply item that can be ordered as a feature code. To order in the United States and Canada, call 1-888-IBM-MEDIA. To order drives in other locations, contact your local provider of IBM storage products or see Storage Media (<http://www.storage.ibm.com/media/>).

The removable disk drives are not a service item. IBM service representatives are not dispatched to service or replace the removable disk drives.

Storing removable disk drives

Store removable disk drives in their protective containers, on a flat surface with the top side up. The storage area must be clean and dry, must have normal room temperature, and be away from any magnetic fields. For best storage life, use the removable disk drives every six months.

Supported SATA adapters and cables

The docking station only supports the SAS/SATA cable that is provided as part of the feature code.

Specifications

Interface

SATA

Bootable

Yes

Physical form factor (internal docking station)

5.25 inch half high

Environmental

SATA Removable Disk Drive	Operating conditions	Non-operating conditions
Temperature	5 to 55 C	-40 to 65 C
Relative humidity	8 - 90% noncondensing	5 - 95% noncondensing
Maximum wet bulb temperature	29.4 C noncondensing	40 C noncondensing
Maximum temperature gradient	20 C per hour	20 C per hour
Altitude	-300 to 3048 m (10,000 ft)	-300 to 12,192 m (40,000 ft)

Supported operating systems

SATA Removable Disk Drive is supported on the following versions of operating systems:

- IBM i 7.1 with the Technology Refresh PTF Group Level 5, or later

Using the SATA Removable Disk Drive for backup and restore

The disk drive is a backup and restore device that can be used as an alternative to tape drives. The removable disk drive is not a replacement for regular disk drives and cannot be used as part of a disk array.

Note: If power is lost during a backup to the disk, the data can be compromised. Verify the data or rerun the backup.

Using the drive with IBM i

IBM i configures the drive as a removable media drive with a name in the format RMSxx, for example, RMS01.

The drive and cartridge are used with optical commands and utilities (for example, WRKOPTVOL and INZOPT), and reports media in the QOPT file system.

See the IBM i documentation for information about using IBM i copy and backup commands.

Setting the write-protect switch

The removable disk drives have a red, write-protect tab that is located on the back of the drive. To write-protect a drive, slide the write-protect tab toward the lock symbol. To disengage write protection, slide the tab to the unlock symbol.

Using the emergency eject function

To eject a removable disk drive, press the eject button. If a drive is stuck, complete the following steps:

1. If you are using the internal docking station, power off the system. If you are using the external docking station, unplug the power cable from the device.
2. Insert a large straightened paper clip (or similar object) into the emergency eject hole. Do not insert the object in the hole at an angle. Keep the object straight and apply some force to eject the drive.
3. When the drive has been ejected by the docking station, grasp the exposed sides of the drive and pull the drive straight out.
4. Restart your system to reset the docking station. If you are using the external docking station, reconnect the power cable for the docking station and then restart the system.

Status lights

yea

Learn about the power indicator and drive indicator status lights on the SATA Removable Disk Drive.

Power indicator

The eject button is illuminated by a power indicator light. The following table describes the operation of the power indicator.

Table 60. Power indicator

Indicator status	Meaning	Description
Off	No power	Docking station does not have power.
Steady green	Ready	Power is on and the docking station is working correctly.
Flashing green	Ejecting	Cartridge is ejecting.
Flashing amber	Fault	Docking station has detected a fault condition with the docking station.

Removable disk drive indicator

The disk drive has an indicator light that displays the status of the drive. The following table describes the operation of the drive indicator.

Table 61. Cartridge indicator

Indicator status	Meaning	Description
Off	Not ready	Drive is not inserted correctly or the docking station has no power.
Steady green	Ready	Drive is ready.
Flashing green	Activity	Drive is reading, writing, or seeking.
Flashing amber	Fault	Docking station has detected a fault condition with the cartridge.

Managing communications devices

Learn about the LAN-Attached Remote Asynchronous Node (RAN) 16 (model 7036-P16).

LAN-Attached Remote Asynchronous Node 16 (model 7036-P16)

Learn about installing, removing, replacing and managing the LAN-Attached Remote Asynchronous Node (RAN) 16 (model 7036-P16).

Note: Additional information can be found on the software CD provided with this device.

7036-P16 description and overview

Learn about the product description, characteristics, and throughput considerations for this device.

Product description

The 7036-P16 is a 16-port EIA-232 LAN-Attached Remote Asynchronous Node (RAN) for Power® Systems servers. The 7036-P16 provides connectivity to asynchronous EIA-232 devices, such as modems, terminal type (tty) terminals, printers, and so on.

The 7036-P16 can be used in a rack-mounted or table-top configuration. Hardware to mount the 7036-P16 in a rack or to use on a table top is included in the package. When installed in a rack, take care with routing the cables to ensure the cables do not interfere with other devices mounted in the rack.

The 7036-P16, when used with Digi RealPort software, will convert the serial data stream to and from attached asynchronous EIA-232 devices into TCP/IP traffic. After the data is on the TCP/IP network, a host system attached to the same network can treat the attached devices as if the devices were connected directly to the host system.

Product characteristics

Safety:

- UL CD certified to EN60950 3rd Edition
- CSA C22.2 No 60950
- UL recognized to UL60950 3rd Edition

Physical characteristics:

- Physical Dimensions: (16.8in./42.7cm)x(6.6in./16.76cm)x(1.6in./4.06cm)
- Weight: 7.05 lb./3.2 kg

Environmental Limits:

- **Operating**
 - Temperature: 0 - 40 C (ambient air temperature)
 - Humidity: 5 - 95% (noncondensing)
 - Wet Bulb: 29 C
 - Altitude: 0 - 7000 ft
- **Storage**
 - Temperature: 1 - 60 C
 - Humidity: 5 - 80% (non-condensing)
 - Wet Bulb: 29 C
- **Shipping**
 - Temperature: -40 to 60 C
 - Humidity: 5 - 100% (non-condensing)
 - Wet Bulb: 29 C

Power Consumption

Table 62. 7036-P16 power consumption

Voltage (input)	Current (amp)	Watt
100 - 250 VAC nominal	0.8 A Maximum	12 W typical
90 - 264 VAC maximum	40A in rush	
47/63 Hz	2A fuse	

Throughput considerations

The limits on throughput are a function of the network and the server or server partition to which the 7036-P16 ports are configured.

System port throughput:

The 7036-P16 supports full-duplex operation up to 230 kbps on all ports. Operation with all 16 ports running full-duplex at 230 kbps is supported.

Network throughput:

The 7036-P16 is an Ethernet attached device and as such, any number may be attached to a given network. However, attaching more devices to any network reduces the overall network throughput and care must be taken to not overload any given network.

Testing has shown that as many as eight 7036-P16 devices may be attached to a network without adversely affecting network throughput. Eight 7036-P16 devices will support up to 128 asynchronous EIA-232 connections. More devices may be attached, but network performance may be adversely affected.

Server or partition throughput:

Each 7036-P16 provides 16-Ports of asynchronous EIA-232 connectivity over a 10/100 Ethernet port at speeds up to 230 kbps. Given that any number of 7036-P16s may be attached to a server or partition, a single server or partition could in effect have a very large number of asynchronous EIA-232 connections that could adversely affect any single server or partition.

Installing 7036-P16 hardware

You might need to install this hardware. Use the procedure in this section to perform this task.

The following information describes the materials and procedures for installing this device. A Phillips screwdriver is required to complete the installation of this unit.

Before you install the 7036-P16 unit, verify that the hardware package contains the following items:

- 7036-P16 unit
- 7036-P16 software and documentation CD
- 7036-P16 Quick Setup Guide
- Brackets to mount 7036-P16 on rack
- Rubber feet for tabletop usage
- Power cord (North American 120 V ac use only)
- RJ-45 to DB25 serial cable DB25 wired per EIA-232 specification
- RJ-45 to DB09 serial cable DB09 matches pin configuration on existing DB09 system ports on Power Systems servers
- RJ-45 wrap plug for diagnostics.

Installing the deskside 7036-P16 unit

To install the deskside 7036-P16 unit, do the following steps:

1. Unpack the hardware.
2. Remove the rubber feet from the plastic bag.
3. Attach the rubber feet to the bottom of the 7036-P16 in the locations indicated.
4. Attach the power cord. A power cord for use in North America is provided.
5. Use an Ethernet cable to connect the 7036-P16 to the network.
6. Connect serial devices as needed.

Installing the rack-mounted 7036-P16 unit

To install the rack-mounted 7036-P16 unit, do the following steps:

1. Unpack the hardware.
2. Remove the right-angle brackets and screws from the plastic bag.
3. Use a Phillips screw to attach the brackets in the predrilled holes on the sides of the 7036-P16.
4. Mount the 7036-P16 in the same location from which the 7036-P16 was removed.
5. Attach the power cord. A power cord for use with 120 V ac is provided.

Optional rack power cord feature codes (FC) are available to connect the 7036-P16 to the rack Power Distribution Unit (PDU). These cords come in various lengths. They are identified by the following feature codes:

- FC 6458: Power Cord (14-foot), Drawer to IBM PDU, 250V/10A

- FC 6672: Power Cord (9-foot), Drawer to IBM PDU, 250V/10A
- FC 6671: Power Cord (5-foot), Drawer to IBM PDU, 250V/10A

The previous features are only available for use in racks less than 25U in size.

6. Use an Ethernet cable to connect the 7036-P16 to the network.
7. Connect serial devices as needed.

Installing Digi RealPort software for the 7036-P16 device

You might need to install the Digi RealPort software on an AIX or Linux host server. Use the procedure in this section to perform this task.

Digi RealPort software-support packages

The following is a list of the software packages available on the software CD provided with the 7036-P16 unit:

- The Digi RealPort software package for AIX supports the following AIX levels:
 - AIX 5L™ 5.2.0.75 (and later)
 - AIX 5L 5.3.0.30 (and later)
- The Digi RealPort software package for Linux supports the following Linux levels:
 - Linux Red Hat Version RHEL4, Update 3
 - Linux SUSE Version SLES 9 SP2

Installing the Digi RealPort software

To install the Digi RealPort software, do the following steps:

1. Install all updates and packages required to bring the operating system to the supported levels.
2. Install all Linux packages required to compile and create binaries from the Digi RealPort Software source code.

The following is a list of Linux packages that are required to install the Digi RealPort software:

- gcc
 - gcc-64bit
 - gcc-c++
 - gcc-g77-64bit
 - gcc-info
 - gcc-locale
 - gcc-objc
 - gcc-objc-64bit
 - kernel sources
 - glibc-devel-64bit
 - ncurses-64bit
 - ncurses-devel
3. Install the Digi RealPort software. To install the software, see the following procedures.

Installing the AIX Digi RealPort software

To install the software package for the AIX environment, do the following steps:

1. Log in to the host server as the root user.
2. Insert the CD-ROM into the CD-ROM drive.
3. Type the following command: `smitty install_all`

4. Press F4.
5. Select `digiasync`, then press Enter.
6. Use the cursor to scroll to ACCEPT new license agreement
7. Press F4.
8. Select Yes, then press Enter.

When installation commences, do not interfere until the installation completes. A successful installation will return an OK message. An unsuccessful installation will return a FAILED message.

If you receive an OK message, continue to the next step. If you receive a failed message, review the `smit.log` file to determine why the installation failed.

9. Press F10.
10. Type: `lslpp -l | grep digi`
If the Digi RealPort package installed correctly, you will receive a message. The following are examples of return messages:
 - `digiasync.realport.obj 3.8.7.0 COMMITTED Digi RealPort Driver`
 - `digiasync.realport.obj 3.8.7.0 COMMITTED Digi RealPort Driver`
11. After the Digi RealPort Software is installed, the user may configure the 7036-P16 onto the network, if it is not already configured. For instructions on how to perform the network configuration, see “Configuring the 7036-P16 into the network” on page 107.

Installing the Linux SUSE Digi RealPort software

To install the software package for the Linux SUSE environment, do the following steps:

1. Log in to the server as the root user.
2. If the CD-ROM is already inserted and mounted, then proceed to step 5.
3. Insert the CD-ROM into the CD-ROM drive.
4. Type: `mount -t auto /dev/cdrom /mnt`
5. Type: `cp /mnt/linux/40002086_M.src.rpm /usr/src/packages/SOURCES`
6. Type: `umount /mnt`
7. Type: `cd /usr/src/linux`
8. Type: `make mrproper`
9. Type: `make oldconfig`
10. Type: `cd /usr/src/packages/SOURCES`
11. Type: `rpmbuild --rebuild 40002086_M.src.rpm`
12. Type: `rpm -i /usr/src/packages/RPMS/ppc64/dgrp-1.9-6.ppc64.rpm`
13. Type: `rpm -qa | grep dgr`
If the Digi RealPort Package installed correctly, the following is an example of the return message:
`dgr-1.9.6`
14. After the Digi RealPort software is installed, the user may configure the 7036-P16 onto the network, if it is not already configured. For instructions on how to perform the network configuration, see “Configuring the 7036-P16 into the network” on page 107.

Installing the Linux Red Hat Digi RealPort software

To install the software package for the Linux Red Hat environment, do the following steps:

1. Log in to the server as the root user.
2. If the CD-ROM is already inserted and mounted, then proceed to step 5.
3. Insert the CD-ROM into the CD-ROM drive.
4. Type: `mount -t auto /dev/cdrom /mnt`

5. Type: `cp /mnt/linux/40002086_M.src.rpm /usr/src/packages/SOURCES`
6. Type: `umount /mnt`
7. Type: `cd /usr/src/packages/SOURCES`
8. Type: `rpmbuild --rebuild 40002086_M.src.rpm`
9. Type: `rpm -i /usr/src/packages/RPMS/ppc64/dgrp-1.9-6.ppc64.rpm`
10. Type: `rpm -qa | grep dgr`
If the Digi RealPort Package installed correctly, the following is an example of the return message:
`dgr-1.9.6`
11. After the Digi RealPort software is installed, the user may configure the 7036-P16 onto the network, if it is not already configured. For instructions on how to perform the network configuration, see “Configuring the 7036-P16 into the network” on page 107.

Configuring the 7036-P16 device and tty

You might need to configure the 7036-P16 as a serial device on a host server. Use the procedure in this section to perform this task.

The task consists of the following steps:

1. Configure the 7036-P16 as a serial device on a host server installed with one of the following operating systems:
 - AIX 5L 5.2.0.75, or later
 - AIX 5L 5.3.0.30, or later
 - Red Hat Enterprise Linux version 4, Update 3, or later
 - SUSE Linux Enterprise Server 9, SP2, or later

This in effect binds the 7036-P16 to the host server.
2. Configure 7036-P16 system ports for use with Digi RealPort software.

Configuring a 7036-P16 device on an AIX host server

Assumptions:

- The target 7036-P16 and the host server are configured on an Ethernet network.
- The target 7036-P16 and the host server are attached to an Ethernet network.
- The Digi RealPort software is installed on the server.

Gather the following information:

- IP Address of the target 7036-P16: [7036-P16 IP Address]
- IP Address of the host server: [Host Server IP Address]
- Root password of target 7036-P16

Configure the 7036-P16 as a serial device on an AIX server:

1. Ensure that the 7036-P16 and the server are on the network. Ping the 7036-P16 by typing the following command: `ping -c 1 [IP Address of target 7036-P16]`
If the 7036-P16 responds to the ping, then it is on the network and the user can proceed to the next step. If the 7036-P16 does not respond to the ping, then the 7036-P16 is not on the network and the user must perform the network configuration procedure, see “Configuring the 7036-P16 into the network” on page 107.
2. Ensure that the Digi RealPort Software is installed on the server. Type the following command: `ls|pp -l | grep digi`
The response indicates that the `digiasync.realport.obj` file is installed.

Note: If the response indicates the Digi RealPort Software is installed then proceed to step 3. If there is no response, then the Digi RealPort Software is not installed and the user must install the Digi RealPort Software, see “Configuring the 7036-P16 into the network” on page 107.

3. Type: smitty devices
4. Use the cursor to select: Digi Device and Terminal Servers, then press Enter.
5. Use the cursor to select: Add a Digi Device and Terminal Servers , then press Enter
6. Use the cursor to select: cts_16_r, then press Enter.
7. Move the cursor to the IP Address box and type: [IP Address], then press Enter. This is the [IP Address of the target 7036-P16] used in Step 1.
Upon successful completion of this command the user will see the following on the screen: Command: OK stdout: yes stderr: no Before command completion, additional instructions may appear. sa[device number] Available
8. Press F3.
9. To configure additional devices, repeat Steps 7. through 10.
10. Press F10 to exit from **smitty** and return to the server's command line.

After the serial device is configured, the terminal type (tty) ports may be configured.

Configuring a 7036-P16 system port tty on an AIX host server

Assumptions:

- The target 7036-P16 and the host server are configured on an Ethernet network.
- The target 7036-P16 and the host server are attached to an Ethernet network.
- The Digi RealPort software is installed on the server.

Gather the following information:

- IP Address of the target 7036-P16: [7036-P16 IP Address]
- IP Address of the host server: [Host Server IP Address]
- Root password of target 7036-P16

Procedure:

1. Ensure that the 7036-P16 and the server are on the network. Ping the 7036-P16 by typing the following command: ping -c 1 [IP Address of target 7036-P16]

Note: If the 7036-P16 responds to the ping, then it is on the network and the user may proceed to the next step. If the 7036-P16 does not respond to the ping, then the 7036-P16 is not on the network and the user must perform the network configuration procedure, see “Configuring the 7036-P16 into the network” on page 107.

2. Ensure that the Digi RealPort Software is installed on the server. Type the following command:

```
lslpp -l | grep digi
```

Note: The response indicates that the **digiasync.realport.obj** file is installed. If the response indicates the Digi RealPort Software is installed then proceed to the next step. If there is no response, then the Digi RealPort Software is not installed and the user must install the Digi RealPort software, see “Configuring the 7036-P16 into the network” on page 107.

3. Type: smitty tty, then press Enter.
4. Use the cursor to select: Add a tty, then press Enter.
5. Use the cursor to select: tty rs232 Asynchronous Terminal, then press Enter.
6. Use the cursor to select: sa[device number] Available IBM LAN Attached RAN 16, then press Enter.
7. Enter a port number not already assigned to a tty, for example 1, and press Enter

Upon successful completion of this command the user sees the following on the screen: Command: OK
stdout: yes stderr: no Before command completion, additional instructions may appear.
tty[number] Available

Note: The [number] is the number assigned by **smitty** as the next available tty device.

8. Press F3.
9. To configure additional tty devices, repeat Steps 7. through 9.
10. Press F10 to exit from **smitty** and return to the server's command line.

This concludes the system port tty configuration on an AIX Server.

Configuring the 7036-P16 as a tty device on a Linux host server

Assumptions:

- The target 7036-P16 and the host server are configured on an Ethernet network.
- The target 7036-P16 and the host server are attached to an Ethernet network.
- The Digi RealPort software is installed on the server.

Gather the following information:

- IP Address of the target 7036-P16: [7036-P16 IP Address]
- IP Address of the host server: [Host Server IP Address]
- Root password of target 7036-P16

Procedure:

1. Ensure that the 7036-P16 and the server are on the network. Ping the 7036-P16 by typing the following command: `ping -c 1 [IP Address of target 7036-P16]`

Note: If the 7036-P16 responds to the ping, then it is on the network and the user may proceed to the next step. If the 7036-P16 does not respond to the ping, then the 7036-P16 is not on the network and the user must perform the network configuration procedure, see “Configuring the 7036-P16 into the network.”

2. Ensure that the Digi RealPort software is installed on the server. Type the following command: `rpm -qa | grep dgr`
The response from the command is: `dgr-1.9.6`

Note: If there is no response, then the Digi RealPort software is not installed and the user must install the Digi RealPort Software, see the Linux Red Hat or the Linux SuSE installation procedure, see “Configuring the 7036-P16 into the network.”

3. Type the following command:
`dgrp_cfg_node -v init [Device ID] [IP Address] [7036-P16 Port(s)]` Where: [Device ID] is any two characters that the user uses to identify the target 7036-P16. [IP Address] is the IP Address of the target 7036-P16. [7036-P16 Port(s)] correspond to the port number(s) being configured.

This concludes the system port tty configuration on a Linux Host server.

Configuring the 7036-P16 into the network

You might need to configure the 7036-P16 device to work within the system network. Use the procedure in this section to perform this task.

The following sections describe methods for configuring the 7036-P16 in a network: the Ethernet method, the ping-ARP method, and the direct-terminal attach method.

Network configuration methods and considerations

The 7036-P16 is an Ethernet device and as such it must be configured onto the network like any other Ethernet device. Various network configuration methods are available to the user.

Configuring the 7036-P16 onto an Ethernet network

If the 7036-P16 is to be used in a network that supports Dynamic Host Configuration Protocol (DHCP), then the configuration will be performed by simply connecting to the network and powering up the 7036-P16. The 7036-P16 is shipped from the factory with the DHCP option enabled.

If DHCP is not supported on the network, then the user must choose between the ping-ARP configuration or the direct terminal attach method.

The ping-ARP configuration method is recommended for the following reasons:

- This method does not require the user to be in the same room as the 7036-P16.
- This method does not require any extra hardware, such as a terminal type (tty) terminal or cabling to attach the 7036-P16 to the tty terminal.
- This method works equally well for AIX and Linux installations.
- This method does not require the 7036-P16 be connected into a network that supports DHCP.

Ping-ARP network configuration method

To configure the 7036-P16 device into the network using this method, do the following steps:

1. Gather the following information from the system or network administrator:
 - MAC Address: [MAC Address] (MAC Address label is on the back of the 7036-P16)
 - IP Address: [IP Address]
 - Default Gateway: [IP Gateway Address]
 - Name Server: [Name Server Address]
 - Subnet Mask: [Subnet mask]
 - Host Name: [Host Name]
 - Domain Name: [Domain Name]
2. Connect the power cord from the 7036-P16 to a power source and turn the power on.
3. Connect the Ethernet cable from the 7036-P16 to an Ethernet network.
4. Log in to a server as root user, and make sure the server is on the same subnet as the 7036-P16.
5. Manually update the server's ARP table.
6. Use the IP address and the 7036-P16's MAC address gathered in Step 1.

The AIX and the Linux command line entries to update the ARP table are different, use the following examples on how to update the server's ARP table:

```
AIX Command: arp -s ether [IP Address] [MAC Address]
Linux Command: arp -v -H ether -s [IP Address] [MAC Address]
```
7. Ping the 7036-P16 using the IP address by typing: `ping -c 1 [IP Address]` The ping may time out before there is a response from the 7036-P16. Repeat the ping until the 7036-P16 responds. The ping response indicates that the IP address has been configured.
8. Use telnet to access the 7036-P16, using the IP address from the ping command: `telnet [IP Address]`
9. Log in to the 7036-P16 as root. Use the default password: `dbps`
10. After logging in, you can change the root password. To change the password, type: `newpass` Follow the prompts provided after entering the command.
11. To view the current configuration, type: `set config`

12. Type the following commands on the 7036-P16 command line using the information gathered in Step 1 to complete the IP Address configuration:

```

set config ip=[IP Address]
set config submask=[Subnet Mask]
set config gateway=[IP Gateway Address]
set config dns=[Name Server Address]
set config dhcp=off
set config hostname=[Host Name]
set config domain=[Domain Name]

```
13. As a precaution, you can deactivate the ping-ARP and RARP options. To deactivate the ping-ARP and RARP options type the following commands:

```

set config Ping-ARP=off
set config RARP=off

```
14. If the user plans to use the Digi RealPort software on the host server to control all the 7036-P16 ports, then the system ports must be configured for use with the Digi RealPort software. Type the following command: `set port range=* dev=rp`
15. Issue the reboot command to the 7036-P16 in order to permanently set the changes. Type the following command: `boot action=reset`

When the 7036-P16 reboots, then the network configuration is complete.

The 7036-P16 can now be accessed through the Ethernet connection. The user can program other features as required. See additional documentation on the *7036-P16 Software and Documentation CD*.

Direct-attach configuration method

A regular tty terminal or a PC running a terminal emulation program, may be attached directly to any one of the 16 ports and commands entered on the 7036-P16 command line to configure the 7036-P16 onto the network.

This method requires the user to be in the same room as the 7036-P16. This method requires the user to have a tty terminal or a PC available. This method requires a serial cable to connect the tty terminal or PC to the server. This method is independent of the operating system installed on the server.

To configure the 7036-P16 device into the network using this method, do the following steps:

1. Gather the following information from the system or network administrator:
 - MAC Address: [MAC Address] (MAC Address label is on the back of the 7036-P16)
 - IP Address: [IP Address]
 - Default Gateway: [IP Gateway Address]
 - Name Server: [Name Server Address]
 - Subnet Mask: [Subnet mask]
 - Host Name: [Host Name]
 - Domain Name: [Domain Name]
2. Connect the power cord from the 7036-P16 to a power source and power up.
3. Connect the serial cable from tty terminal to the 7036-P16.
4. Log in to the 7036-P16 as the root user, use the default password dbps.
5. After login, you can change the root password. Type: `newpass`
6. To view the current configuration, type: `set config`
7. Type the following commands on the 7036-P16 command line using the information gathered in Step 1 to complete the IP Address configuration:

```

set config ip=[IP Address]
set config submask=[Subnet Mask]
set config gateway=[IP Gateway Address]

```

```
set config dns=[Name Server Address]
set config dhcp=off
set config hostname=[Host Name]
set config domain=[Domain Name]
```

8. As a precaution, you can deactivate the Ping-ARP and RARP options. To deactivate the Ping-ARP and RARP options type the following commands:

```
set config Ping-ARP=off
set config RARP=off
```
9. If you plan to use the Digi RealPort software on the host server to control all the 7036-P16 ports, then the system ports must be configured for use with the Digi RealPort software. Type the following command: `set port range=* dev=rp`
10. Issue the reboot command to the 7036-P16 in order to permanently set the changes. Type the following command: `boot action=reset`

When the 7036-P16 reboots, then the network configuration is complete.

The 7036-P16 may now be accessed via the Ethernet connection. The user can program other features as required. See additional documentation on the 7036-P16 Software and Documentation CD.

Using diagnostic aids for the 7036-P16

You might need to use diagnostic programs to identify hardware problems. Use the procedure in this section to perform this task.

The 7036-P16 is not supported under AIX Diagnostics. A means to diagnose hardware problems with the 7036-P16 is provided by an executable program.

The purpose of this program is to diagnose hardware problems with the 7036-P16, such as bad connectors, faulty electronic components, and so on. The diagnostic is not intended to resolve protocol problems, network problems or a faulty host server to which the 7036-P16 may be attached.

Requirements for using the 7036-P16 diagnostic program

- The 7036-P16 and the AIX host server must be on the same network.
- The Digi RealPort Software for AIX Package must be installed.
- The user must ensure the problems are not caused by a faulty host server, the network or a device attached to any one of the 16 system ports.
- The Diagnostic Program is run from the AIX host server.
- Wrap Plug IBM part number 43G0928.

7036-P16 diagnostic program capabilities

- Wrap data on each of the 16 system ports
- Monitor data on each of the 16 system ports
- Provide VPD (vital production data)

Using the 7036-P16 diagnostic program

1. Log in to the AIX host server as root.
2. From the root home directory type:

```
./usr/sbin/tty/dpa-ncxa
```
3. Press Enter.
4. The next screen will present a list of all the 7036-P16s configured on the host server. The list includes the device name and the IP Address for each 7036-P16. The user should look at the bottom of the screen for options.
5. Select a 7036-P16 on the list by using the cursor keys. The 7036-P16 selected is highlighted.

6. Type D to see the 7036-P16 product information.
7. Press enter to test an individual terminal type (tty) port on the selected 7036-P16. The next screen will present Port-1 of the 7036-P16 that was selected.
8. To select a different tty port, use the cursor keys to either increment or decrement the port number.
9. Once a tty port is selected, then select one of the following items:
 - a. Wrap data by typing a T. If this option is chosen, use wrap plug part number 43G0928. Insert the wrap plug into the tty port.
 - b. Monitor the data on the selected port by typing a D.
10. To exit the diagnostic program, press ESC.

General purpose diagnostic procedures, visual inspections

Ethernet cables

- Ensure an Ethernet cable is attached to the 7036-P16 and the host server.
- Ensure the Ethernet cable is wired correctly.
- Ensure the Ethernet cable is good.

Serial cables

- Ensure a serial cable is attached to every 7036-P16 port that is in use.
- Ensure the serial cables are wired correctly.
- Ensure the serial cables are good.

Investigating Ethernet network problems associated with the 7036-P16

1. Gather the following information:
 - For the 7036-P16:
 - MAC Address: [MAC Address] (MAC Address label is on the back of the 7036-P16)
 - IP Address: [7036-P16 IP Address]
 - Default Gateway: [IP Gateway Address]
 - Name Server: [Name Server Address]
 - Host Name: [Host Name] (if a host name is assigned)
 - For the host server:
 - Machine Type and Model
 - AIX Level
 - IP Address: [Host server IP Address]
 - Default Gateway: [IP Gateway Address]
 - Name Server: [Name Server Address]
 - Host Name: [Host Name] (if a host name is assigned)
2. Ping the 7036-P16 from the host server by typing: `ping -c 1 [7036-P16 IP Address]`
If the 7036-P16 responds to the ping, then both devices are on the network; the problem is not a network attachment problem. If the ping times out, then either the 7036-P16 or the host server is not on the network.
3. Use traceroute to see where the link between the 7036-P16 and the host server is broken. Type:
`traceroute [7036-P16 IP Address]`

Replacing and reconfiguring the 7036-P16

You might need to create a 7036-P16 configuration file, reconfigure a 7036-P16 from a stored configuration file, or replace a 7036-P16. Use the procedures in this section to perform this task.

This section provides instructions on how to perform the following tasks:

- Creating a 7036-P16 configuration file
- Reconfiguring a 7036-P16 from a stored configuration file
- Replacing a 7036-P16

Creating a 7036-P16 configuration file

Create a copy of the 7036-P16 configuration and to store it on the host server.

Hardware requirements:

- AIX or Linux host server with web access
- 7036-P16 attached to an Ethernet network

Gather the following information:

- IP Address of the target 7036-P16: [7036-P16 IP Address]
- IP Address of the host server: [Host Server IP Address]
- Root password of target 7036-P16

7036-P16 configuration file creation methods

The following are methods for creating a 7036-P16 configuration file:

- Web user interface method
 - Command line method
- Access the 7036-P16 command line and enter commands directly onto the 7036-P16. This method requires TFTP to be enabled on the host server.

Web user interface method

To create a configuration file using the web user interface method, do the following steps:

1. Use the host server to access the web interface of the target 7036-P16 by entering the 7036-P16 IP address in a browser's URL window, then log in as the root user.
2. Select Backup/Restore
3. Select Backup
4. Select Save
5. The program will create a file named **backup.cfg**. Consider changing that name to something more meaningful. Example: backup_[IP Address].txt
6. When the task is completed a Download Complete message will be posted to the screen.

Command line method

To create a configuration file using the command line method, do the following steps:

1. Ensure the TFTP daemon is enabled on the host server. On an AIX server type the following on the command line: `ps -ef | grep tftp`
If the TFTP daemon is enabled, the response will include two active TFTP processes and the user should proceed to Step 8. If the response indicates that only the grep process is active, then the TFTP daemon must be enabled.
2. To enable the TFTP daemon, type the following command: `smitty subsystem`
3. Select Start a Subsystem, then press Enter.
4. Press F4
5. Search the resulting list for `tftpd`, then press Enter.
6. Telnet to the target 7036-P16. Type: `telnet [IP Address of target 7036-P16]`, then press Enter.

7. Login as the root user, use the root password.
8. Type the following on the 7036-P16 command line:
`cpconf tohost=[Host Server IP Address]:/tmp/backup_[IP Address].txt`
The complete IP and terminal type (tty) port configuration information is now captured in the **backup_[IP Address].txt** file. If the user changes the configuration, the user is strongly advised to recreate the **backup_[IP Address].txt** file. The user should make a note of the file name created.

Reconfiguring a 7036-P16 from a stored configuration file

Use a stored configuration file when replacing a 7036-P16.

Hardware requirements:

- AIX or Linux host server with web access
- 7036-P16 attached to an Ethernet network

Gather the following information:

- IP Address of the target 7036-P16: [7036-P16 IP Address]
- IP Address of the host server: [Host Server IP Address]
- Root password of target 7036-P16

7036-P16 reconfiguration methods

The following are methods for creating a 7036-P16 configuration file:

- Web user interface method
- Command line method

Access the 7036-P16 command line and enter commands directly onto the 7036-P16. This method requires TFTP to be enabled on the host server.

Web user interface method

To modify the configuration file using the web user interface method, do the following steps:

1. Use the host server to access the web interface of the target 7036-P16 by entering the 7036-P16 IP address in a browser's URL window, then log in as the root user.
2. Select Backup/Restore
3. Select Browse and navigate to the directory where the stored file is kept on the host server.
4. Select the stored configuration file and click on Open. For example: backup_[IP Address].txt The complete path to the stored file will appear in the Browse window.
5. Click on Restore.
6. Wait for the configuration to complete, then click on Done.
7. Click on Reboot.
8. The task is complete when the 7036-P16 reboots.

Command line method

To modify the configuration file using the command line method, do the following steps:

1. Telnet to the target 7036-P16. Type: telnet [IP Address of target 7036-P16], then press Enter.
2. Login as root, use the root password.
3. To reconfigure the 7036-P16, type the following command:
`cpconf fromhost=[Host Server IP Address]:/tmp/backup_[IP Address].txt`
4. Reboot the 7036-P16. Type: boot action=reset

5. When the 7036-P16 reboots, then the task is complete.

Replacing a 7036-P16

Attention: Before replacing a 7036-P16, create a 7036-P16 configuration file.

You need a Phillips screwdriver to replace this unit.

To replace a 7036-P16 unit, do the following steps:

1. Gather the following IP information for the 7036-P16 unit to be replaced:
 - MAC Address: [MAC Address] (MAC Address label is on the back of the 7036-P16)
 - IP Address: [IP Address]
 - Default Gateway: [IP Gateway Address]
 - Name Server: [Name Server Address]
 - Subnet Mask: [Subnet mask]
 - Host Name: [Host Name]
 - Domain Name: [Domain Name]
2. Power off the 7036-P16.
3. Remove the power cord.
4. Remove the Ethernet cable.
5. Remove each serial cable, and make sure each cable is marked indicating from which tty port it was removed.
6. If the 7036-P16 is installed as a desktop unit, then remove the rubber feet from the plastic bag and attach them to the replacement 7036-P16.
7. If the 7036-P16 is used as a rack mounted device, then undo the screws from the rack and remove the 7036-P16 from the rack.
8. Remove the replacement 7036-P16 unit from the shipping package.
9. Remove the right angle brackets and screws from the plastic bag.
10. Use a Phillips screw to attach the brackets in the predrilled holes on the sides of the 7036-P16.
11. Mount the new 7036-P16 in the same location from which the previous 7036-P16 was removed.
12. Attach the power cord.
13. Attach the Ethernet cable.
14. Attach the serial cables, using the markings from Step 5 in order to restore each cable to its previous port.
15. After the 7036 is configured on the network, telnet to the target 7036-P16. Type: telnet [IP Address of target 7036-P16]
16. Log in as the root user.
17. To reconfigure the 7036-P16, type the following command:
`cpconf fromhost=[Host Server IP Address]:/tmp/backup_[IP Address].txt`

Field replacement units for the 7036-P16

Identify field replacement units (FRUs) for the 7036-P16.

The following table lists the FRUs for the 7036-P16.

Table 63. FRUs for the 7036-P16

Part number	Description
80P6911	7036-P16 FRU
10N7714	7036-P16 Software and Documentation CD. Form Number: LCD8-0170-01

Table 63. FRUs for the 7036-P16 (continued)

Part number	Description
03N6839	7036-P16 Rubber Feet and Brackets Accessory FRU
39J5823	RJ-45 to DB09 (male) cable
12H1204	DB25 to DB25 (male) cable

Notices

This information was developed for products and services offered in the U.S.A.

The manufacturer may not offer the products, services, or features discussed in this document in other countries. Consult the manufacturer's representative for information on the products and services currently available in your area. Any reference to the manufacturer's product, program, or service is not intended to state or imply that only that product, program, or service may be used. Any functionally equivalent product, program, or service that does not infringe any intellectual property right of the manufacturer may be used instead. However, it is the user's responsibility to evaluate and verify the operation of any product, program, or service.

The manufacturer may have patents or pending patent applications covering subject matter described in this document. The furnishing of this document does not grant you any license to these patents. You can send license inquiries, in writing, to the manufacturer.

The following paragraph does not apply to the United Kingdom or any other country where such provisions are inconsistent with local law: THIS PUBLICATION IS PROVIDED "AS IS" WITHOUT WARRANTY OF ANY KIND, EITHER EXPRESS OR IMPLIED, INCLUDING, BUT NOT LIMITED TO, THE IMPLIED WARRANTIES OF NON-INFRINGEMENT, MERCHANTABILITY OR FITNESS FOR A PARTICULAR PURPOSE. Some states do not allow disclaimer of express or implied warranties in certain transactions, therefore, this statement may not apply to you.

This information could include technical inaccuracies or typographical errors. Changes are periodically made to the information herein; these changes will be incorporated in new editions of the publication. The manufacturer may make improvements and/or changes in the product(s) and/or the program(s) described in this publication at any time without notice.

Any references in this information to websites not owned by the manufacturer are provided for convenience only and do not in any manner serve as an endorsement of those websites. The materials at those websites are not part of the materials for this product and use of those websites is at your own risk.

The manufacturer may use or distribute any of the information you supply in any way it believes appropriate without incurring any obligation to you.

Any performance data contained herein was determined in a controlled environment. Therefore, the results obtained in other operating environments may vary significantly. Some measurements may have been made on development-level systems and there is no guarantee that these measurements will be the same on generally available systems. Furthermore, some measurements may have been estimated through extrapolation. Actual results may vary. Users of this document should verify the applicable data for their specific environment.

Information concerning products not produced by this manufacturer was obtained from the suppliers of those products, their published announcements or other publicly available sources. This manufacturer has not tested those products and cannot confirm the accuracy of performance, compatibility or any other claims related to products not produced by this manufacturer. Questions on the capabilities of products not produced by this manufacturer should be addressed to the suppliers of those products.

All statements regarding the manufacturer's future direction or intent are subject to change or withdrawal without notice, and represent goals and objectives only.

The manufacturer's prices shown are the manufacturer's suggested retail prices, are current and are subject to change without notice. Dealer prices may vary.

This information is for planning purposes only. The information herein is subject to change before the products described become available.

This information contains examples of data and reports used in daily business operations. To illustrate them as completely as possible, the examples include the names of individuals, companies, brands, and products. All of these names are fictitious and any similarity to the names and addresses used by an actual business enterprise is entirely coincidental.

If you are viewing this information in softcopy, the photographs and color illustrations may not appear.

The drawings and specifications contained herein shall not be reproduced in whole or in part without the written permission of the manufacturer.

The manufacturer has prepared this information for use with the specific machines indicated. The manufacturer makes no representations that it is suitable for any other purpose.

The manufacturer's computer systems contain mechanisms designed to reduce the possibility of undetected data corruption or loss. This risk, however, cannot be eliminated. Users who experience unplanned outages, system failures, power fluctuations or outages, or component failures must verify the accuracy of operations performed and data saved or transmitted by the system at or near the time of the outage or failure. In addition, users must establish procedures to ensure that there is independent data verification before relying on such data in sensitive or critical operations. Users should periodically check the manufacturer's support websites for updated information and fixes applicable to the system and related software.

Homologation statement

This product may not be certified in your country for connection by any means whatsoever to interfaces of public telecommunications networks. Further certification may be required by law prior to making any such connection. Contact an IBM representative or reseller for any questions.

Trademarks

IBM, the IBM logo, and ibm.com are trademarks or registered trademarks of International Business Machines Corp., registered in many jurisdictions worldwide. Other product and service names might be trademarks of IBM or other companies. A current list of IBM trademarks is available on the web at www.ibm.com/legal/copytrade.shtml.

Linux is a registered trademark of Linus Torvalds in the United States, other countries, or both.

Red Hat, the Red Hat "Shadow Man" logo, and all Red Hat-based trademarks and logos are trademarks or registered trademarks of Red Hat, Inc., in the United States and other countries.

Electronic emission notices

When attaching a monitor to the equipment, you must use the designated monitor cable and any interference suppression devices supplied with the monitor.

Class A Notices

The following Class A statements apply to the IBM servers that contain the POWER7 processor and its features unless designated as electromagnetic compatibility (EMC) Class B in the feature information.

Federal Communications Commission (FCC) statement

Note: This equipment has been tested and found to comply with the limits for a Class A digital device, pursuant to Part 15 of the FCC Rules. These limits are designed to provide reasonable protection against harmful interference when the equipment is operated in a commercial environment. This equipment generates, uses, and can radiate radio frequency energy and, if not installed and used in accordance with the instruction manual, may cause harmful interference to radio communications. Operation of this equipment in a residential area is likely to cause harmful interference, in which case the user will be required to correct the interference at his own expense.

Properly shielded and grounded cables and connectors must be used in order to meet FCC emission limits. IBM is not responsible for any radio or television interference caused by using other than recommended cables and connectors or by unauthorized changes or modifications to this equipment. Unauthorized changes or modifications could void the user's authority to operate the equipment.

This device complies with Part 15 of the FCC rules. Operation is subject to the following two conditions: (1) this device may not cause harmful interference, and (2) this device must accept any interference received, including interference that may cause undesired operation.

Industry Canada Compliance Statement

This Class A digital apparatus complies with Canadian ICES-003.

Avis de conformité à la réglementation d'Industrie Canada

Cet appareil numérique de la classe A est conforme à la norme NMB-003 du Canada.

European Community Compliance Statement

This product is in conformity with the protection requirements of EU Council Directive 2004/108/EC on the approximation of the laws of the Member States relating to electromagnetic compatibility. IBM cannot accept responsibility for any failure to satisfy the protection requirements resulting from a non-recommended modification of the product, including the fitting of non-IBM option cards.

This product has been tested and found to comply with the limits for Class A Information Technology Equipment according to European Standard EN 55022. The limits for Class A equipment were derived for commercial and industrial environments to provide reasonable protection against interference with licensed communication equipment.

European Community contact:
IBM Deutschland GmbH
Technical Regulations, Department M372
IBM-Allee 1, 71139 Ehningen, Germany
Tele: +49 7032 15 2941
email: lugi@de.ibm.com

Warning: This is a Class A product. In a domestic environment, this product may cause radio interference, in which case the user may be required to take adequate measures.

VCCI Statement - Japan

この装置は、クラスA 情報技術装置です。この装置を家庭環境で使用すると電波妨害を引き起こすことがあります。この場合には使用者が適切な対策を講ずるよう要求されることがあります。

VCCI-A

The following is a summary of the VCCI Japanese statement in the box above:

This is a Class A product based on the standard of the VCCI Council. If this equipment is used in a domestic environment, radio interference may occur, in which case, the user may be required to take corrective actions.

Japanese Electronics and Information Technology Industries Association (JEITA) Confirmed Harmonics Guideline (products less than or equal to 20 A per phase)

高調波ガイドライン適合品

Japanese Electronics and Information Technology Industries Association (JEITA) Confirmed Harmonics Guideline with Modifications (products greater than 20 A per phase)

高調波ガイドライン準用品

Electromagnetic Interference (EMI) Statement - People's Republic of China

声 明

此为 A 级产品,在生活环境
中,该产品可能会造成无线电干
扰。在这种情况下,可能需要用
户对其干扰采取切实可行的措
施。

Declaration: This is a Class A product. In a domestic environment this product may cause radio interference in which case the user may need to perform practical action.

Electromagnetic Interference (EMI) Statement - Taiwan

警告使用者：
這是甲類的資訊產品，在居住的環境中使用時，可能會造成射頻干擾，在這種情況下，使用者會被要求採取某些適當的對策。

The following is a summary of the EMI Taiwan statement above.

Warning: This is a Class A product. In a domestic environment this product may cause radio interference in which case the user will be required to take adequate measures.

IBM Taiwan Contact Information:

台灣IBM 產品服務聯絡方式：
台灣國際商業機器股份有限公司
台北市松仁路7號3樓
電話：0800-016-888

Electromagnetic Interference (EMI) Statement - Korea

이 기기는 업무용(A급)으로 전자파적합기기로서 판매자 또는 사용자는 이 점을 주의하시기 바라며, 가정외의 지역에서 사용하는 것을 목적으로 합니다.

Germany Compliance Statement

Deutschsprachiger EU Hinweis: Hinweis für Geräte der Klasse A EU-Richtlinie zur Elektromagnetischen Verträglichkeit

Dieses Produkt entspricht den Schutzanforderungen der EU-Richtlinie 2004/108/EG zur Angleichung der Rechtsvorschriften über die elektromagnetische Verträglichkeit in den EU-Mitgliedsstaaten und hält die Grenzwerte der EN 55022 Klasse A ein.

Um dieses sicherzustellen, sind die Geräte wie in den Handbüchern beschrieben zu installieren und zu betreiben. Des Weiteren dürfen auch nur von der IBM empfohlene Kabel angeschlossen werden. IBM übernimmt keine Verantwortung für die Einhaltung der Schutzanforderungen, wenn das Produkt ohne Zustimmung von IBM verändert bzw. wenn Erweiterungskomponenten von Fremdherstellern ohne Empfehlung von IBM gesteckt/eingebaut werden.

EN 55022 Klasse A Geräte müssen mit folgendem Warnhinweis versehen werden:
"Warnung: Dieses ist eine Einrichtung der Klasse A. Diese Einrichtung kann im Wohnbereich Funk-Störungen verursachen; in diesem Fall kann vom Betreiber verlangt werden, angemessene Maßnahmen zu ergreifen und dafür aufzukommen."

Deutschland: Einhaltung des Gesetzes über die elektromagnetische Verträglichkeit von Geräten

Dieses Produkt entspricht dem "Gesetz über die elektromagnetische Verträglichkeit von Geräten (EMVG)". Dies ist die Umsetzung der EU-Richtlinie 2004/108/EG in der Bundesrepublik Deutschland.

Zulassungsbescheinigung laut dem Deutschen Gesetz über die elektromagnetische Verträglichkeit von Geräten (EMVG) (bzw. der EMC EG Richtlinie 2004/108/EG) für Geräte der Klasse A

Dieses Gerät ist berechtigt, in Übereinstimmung mit dem Deutschen EMVG das EG-Konformitätszeichen - CE - zu führen.

Verantwortlich für die Einhaltung der EMV Vorschriften ist der Hersteller:
International Business Machines Corp.
New Orchard Road
Armonk, New York 10504
Tel: 914-499-1900

Der verantwortliche Ansprechpartner des Herstellers in der EU ist:
IBM Deutschland GmbH
Technical Regulations, Abteilung M372
IBM-Allee 1, 71139 Ehningen, Germany
Tel: +49 7032 15 2941
email: lugi@de.ibm.com

Generelle Informationen:

Das Gerät erfüllt die Schutzanforderungen nach EN 55024 und EN 55022 Klasse A.

Electromagnetic Interference (EMI) Statement - Russia

ВНИМАНИЕ! Настоящее изделие относится к классу А.
В жилых помещениях оно может создавать радиопомехи, для снижения которых необходимы дополнительные меры

Class B Notices

The following Class B statements apply to features designated as electromagnetic compatibility (EMC) Class B in the feature installation information.

Federal Communications Commission (FCC) statement

This equipment has been tested and found to comply with the limits for a Class B digital device, pursuant to Part 15 of the FCC Rules. These limits are designed to provide reasonable protection against harmful interference in a residential installation.

This equipment generates, uses, and can radiate radio frequency energy and, if not installed and used in accordance with the instructions, may cause harmful interference to radio communications. However, there is no guarantee that interference will not occur in a particular installation.

If this equipment does cause harmful interference to radio or television reception, which can be determined by turning the equipment off and on, the user is encouraged to try to correct the interference by one or more of the following measures:

- Reorient or relocate the receiving antenna.
- Increase the separation between the equipment and receiver.
- Connect the equipment into an outlet on a circuit different from that to which the receiver is connected.
- Consult an IBM-authorized dealer or service representative for help.

Properly shielded and grounded cables and connectors must be used in order to meet FCC emission limits. Proper cables and connectors are available from IBM-authorized dealers. IBM is not responsible for any radio or television interference caused by unauthorized changes or modifications to this equipment. Unauthorized changes or modifications could void the user's authority to operate this equipment.

This device complies with Part 15 of the FCC rules. Operation is subject to the following two conditions: (1) this device may not cause harmful interference, and (2) this device must accept any interference received, including interference that may cause undesired operation.

Industry Canada Compliance Statement

This Class B digital apparatus complies with Canadian ICES-003.

Avis de conformité à la réglementation d'Industrie Canada

Cet appareil numérique de la classe B est conforme à la norme NMB-003 du Canada.

European Community Compliance Statement

This product is in conformity with the protection requirements of EU Council Directive 2004/108/EC on the approximation of the laws of the Member States relating to electromagnetic compatibility. IBM cannot accept responsibility for any failure to satisfy the protection requirements resulting from a non-recommended modification of the product, including the fitting of non-IBM option cards.

This product has been tested and found to comply with the limits for Class B Information Technology Equipment according to European Standard EN 55022. The limits for Class B equipment were derived for typical residential environments to provide reasonable protection against interference with licensed communication equipment.

European Community contact:
IBM Deutschland GmbH
Technical Regulations, Department M372
IBM-Allee 1, 71139 Ehningen, Germany
Tele: +49 7032 15 2941
email: lugi@de.ibm.com

VCCI Statement - Japan

この装置は、クラスB情報技術装置です。この装置は、家庭環境で使用することを目的としていますが、この装置がラジオやテレビジョン受信機に近接して使用されると、受信障害を引き起こすことがあります。

取扱説明書に従って正しい取り扱いをして下さい。 VCCI-B

Japanese Electronics and Information Technology Industries Association (JEITA) Confirmed Harmonics Guideline (products less than or equal to 20 A per phase)

高調波ガイドライン適合品

Japanese Electronics and Information Technology Industries Association (JEITA) Confirmed Harmonics Guideline with Modifications (products greater than 20 A per phase)

高調波ガイドライン準用品

IBM Taiwan Contact Information

台灣IBM 產品服務聯絡方式：
台灣國際商業機器股份有限公司
台北市松仁路7號3樓
電話：0800-016-888

Electromagnetic Interference (EMI) Statement - Korea

이 기기는 가정용(B급)으로 전자파적합기기로서 주로 가정에서 사용하는 것을 목적으로 하며, 모든 지역에서 사용할 수 있습니다.

Germany Compliance Statement

Deutschsprachiger EU Hinweis: Hinweis für Geräte der Klasse B EU-Richtlinie zur Elektromagnetischen Verträglichkeit

Dieses Produkt entspricht den Schutzanforderungen der EU-Richtlinie 2004/108/EG zur Angleichung der Rechtsvorschriften über die elektromagnetische Verträglichkeit in den EU-Mitgliedsstaaten und hält die Grenzwerte der EN 55022 Klasse B ein.

Um dieses sicherzustellen, sind die Geräte wie in den Handbüchern beschrieben zu installieren und zu betreiben. Des Weiteren dürfen auch nur von der IBM empfohlene Kabel angeschlossen werden. IBM übernimmt keine Verantwortung für die Einhaltung der Schutzanforderungen, wenn das Produkt ohne Zustimmung von IBM verändert bzw. wenn Erweiterungskomponenten von Fremdherstellern ohne Empfehlung von IBM gesteckt/eingebaut werden.

Deutschland: Einhaltung des Gesetzes über die elektromagnetische Verträglichkeit von Geräten

Dieses Produkt entspricht dem "Gesetz über die elektromagnetische Verträglichkeit von Geräten (EMVG)". Dies ist die Umsetzung der EU-Richtlinie 2004/108/EG in der Bundesrepublik Deutschland.

Zulassungsbescheinigung laut dem Deutschen Gesetz über die elektromagnetische Verträglichkeit von Geräten (EMVG) (bzw. der EMC EG Richtlinie 2004/108/EG) für Geräte der Klasse B

Dieses Gerät ist berechtigt, in Übereinstimmung mit dem Deutschen EMVG das EG-Konformitätszeichen - CE - zu führen.

Verantwortlich für die Einhaltung der EMV Vorschriften ist der Hersteller:
International Business Machines Corp.
New Orchard Road
Armonk, New York 10504
Tel: 914-499-1900

Der verantwortliche Ansprechpartner des Herstellers in der EU ist:
IBM Deutschland GmbH
Technical Regulations, Abteilung M372
IBM-Allee 1, 71139 Ehningen, Germany
Tel: +49 7032 15 2941
email: lugi@de.ibm.com

Generelle Informationen:

Das Gerät erfüllt die Schutzanforderungen nach EN 55024 und EN 55022 Klasse B.

Terms and conditions

Permissions for the use of these publications are granted subject to the following terms and conditions.

Applicability: These terms and conditions are in addition to any terms of use for the IBM website.

Personal Use: You may reproduce these publications for your personal, noncommercial use provided that all proprietary notices are preserved. You may not distribute, display or make derivative works of these publications, or any portion thereof, without the express consent of IBM.

Commercial Use: You may reproduce, distribute and display these publications solely within your enterprise provided that all proprietary notices are preserved. You may not make derivative works of these publications, or reproduce, distribute or display these publications or any portion thereof outside your enterprise, without the express consent of IBM.

Rights: Except as expressly granted in this permission, no other permissions, licenses or rights are granted, either express or implied, to the Publications or any information, data, software or other intellectual property contained therein.

IBM reserves the right to withdraw the permissions granted herein whenever, in its discretion, the use of the publications is detrimental to its interest or, as determined by IBM, the above instructions are not being properly followed.

You may not download, export or re-export this information except in full compliance with all applicable laws and regulations, including all United States export laws and regulations.

IBM MAKES NO GUARANTEE ABOUT THE CONTENT OF THESE PUBLICATIONS. THE PUBLICATIONS ARE PROVIDED "AS-IS" AND WITHOUT WARRANTY OF ANY KIND, EITHER EXPRESSED OR IMPLIED, INCLUDING BUT NOT LIMITED TO IMPLIED WARRANTIES OF MERCHANTABILITY, NON-INFRINGEMENT, AND FITNESS FOR A PARTICULAR PURPOSE.



Printed in USA