

Power Systems

*Managing PCI adapters for the
8231-E2B, 8231-E1C, 8231-E1D,
8231-E2C, 8231-E2D, or 8268-E1D*

IBM

Power Systems

*Managing PCI adapters for the
8231-E2B, 8231-E1C, 8231-E1D,
8231-E2C, 8231-E2D, or 8268-E1D*

IBM

Note

Before using this information and the product it supports, read the information in “Safety notices” on page v, “Notices” on page 227, the *IBM Systems Safety Notices* manual, G229-9054, and the *IBM Environmental Notices and User Guide*, Z125-5823.

This edition applies to IBM Power Systems servers that contain the POWER7 processor and to all associated models.

© Copyright IBM Corporation 2010, 2015.

US Government Users Restricted Rights – Use, duplication or disclosure restricted by GSA ADP Schedule Contract with IBM Corp.

Contents

Safety notices	v
---------------------------------	----------

Managing PCI adapters for the 8231-E2B, 8231-E1C, 8231-E1D, 8231-E2C, 8231-E2D, or 8268-E1D	1
--	----------

Overview of managing PCI adapters	1
Backplane daughter cards and RAID enablement cards	2
PCI Express.	3
Handling static sensitive devices.	3
Important partitioning considerations with dual-slot and multi-adapter configurations.	4
PCI adapter information by feature type for the 8231-E2B, 8231-E1C, 8231-E1D, 8231-E2C, 8231-E2D, or 8268-E1D	6
PCIe LP 4-Port Async EIA-232 Adapter (FC 5277; CCIN 57D2).	6
PCIe 2-port Async EIA-232 Adapter (FC 5289; CCIN 57D4)	9
PCIe LP 2-port Async EIA-232 Adapter (FC 5290; CCIN 57D4)	10
4-port Async EIA-232 PCIe Adapter (FC 5785; CCIN 57D2)	12
PCIe LP 8 Gb 2-Port Fibre Channel Adapter (FC 5273 and FC EL2N; CCIN 577D).	15
4 Gigabit PCI Express Dual Port Fibre Channel Adapter (FC 5276; CCIN 5774)	18
PCIe3 LP 16 Gb 2-port Fibre Channel Adapter (FC EN0B; CCIN 577F).	22
8 Gigabit PCI Express Dual Port Fibre Channel Adapter (FC 5735; CCIN 577D).	26
4 Gigabit PCI Express Single Port Fibre Channel Adapter (FC 5773; CCIN 5773)	29
4 Gigabit PCI Express Dual Port Fibre Channel Adapter (FC 5774; CCIN 5774)	34
PCIe2 LP 8 Gb 4-port Fibre Channel Adapter (FC EN0Y; CCIN EN0Y).	38
PCIe LP POWER GXT145 Graphics Accelerator (FC 5269; CCIN 5269)	41
PCIe2 LP 3D Graphics Adapter x1 (FC EC41)	46
POWER GXT145 PCI Express Graphics Accelerator (FC 5748; CCIN 5748)	50
PCIe2 LP 4-port (10Gb+1GbE) Copper SFP+RJ45 Adapter (FC EN0V; CCIN 2CC3)	54
PCIe2 LP 4-Port (10Gb+1GbE) SR+RJ45 Adapter (FC EN0T; CCIN 2CC3)	58
PCIe2 LP 2-port 10 GbE BaseT RJ45 Adapter (FC EN0X; CCIN 2CC4)	62
PCIe3 RAID SAS quad-port 6 Gb Adapter (FC EJ0J; CCIN 57B4)	64
PCIe3 12 GB Cache RAID SAS quad-port 6 Gb Adapter (FC EJ0L; CCIN 57CE).	67
PCIe3 RAID SAS quad-port 6 Gb LP Adapter (FC EJ0M; CCIN 57B4)	70
PCIe3 4 x8 SAS Port Adapter (FC EJ10; CCIN 57B4)	72
PCIe3 LP 4 x8 SAS Port Adapter (FC EJ11; CCIN 57B4).	74
PCIe2 LP 4-port 1GbE Adapter (FC 5260; CCIN 576F)	76
PCIe LP 10-Gb FCoE 2-port Adapter (FC 5270; CCIN 2B3B)	79
PCIe LP 4-Port 10/100/1000 Base-TX Ethernet Adapter (FC 5271; CCIN 5717)	82
PCIe LP 10GbE CX4 1-port Adapter (FC 5272; CCIN 5732).	87
PCIe LP 2-Port 1GbE SX Adapter (FC 5274; CCIN 5768)	90
PCIe LP 10GbE SR 1-port Adapter (FC 5275; CCIN 5769)	96
PCIe2 LP 2x10GbE SFP+ Copper 2x1GbE UTP Adapter (FC 5279; CCIN 2B52)	99
PCIe2 LP 2x10GbE SR 2x1GbE UTP Adapter (FC 5280; CCIN 2B54)	102
PCIe LP 2-Port 1GbE TX Adapter (FC 5281; CCIN 5767)	103
PCIe2 LP 2-port 10GbE SR Adapter (FC 5284; CCIN 5287)	108
PCIe2 LP 2-port 10GbE SFP+ Copper Adapter (FC 5286; CCIN 5288)	110
10-Gb FCoE PCIe Dual Port Adapter (FC 5708; CCIN 2B3B)	112
4-Port 10/100/1000 Base-TX PCI Express Adapter (FC 5717; CCIN 5717)	115
10 Gigabit Ethernet-CX4 PCI Express Adapter (FC 5732; CCIN 5732)	120
2-Port 10/100/1000 Base-TX Ethernet PCI Express Adapter (FC 5767; CCIN 5767)	123
2-Port Gigabit Ethernet-SX PCI Express Adapter (FC 5768; CCIN 5768)	128
10 Gigabit Ethernet-SR PCI Express Adapter (FC 5769; CCIN 5769)	133
10 Gigabit Ethernet-LR PCI Express Adapter (FC 5772; CCIN 576E)	137
PCIe2 4-port 1 GbE Adapter (FC 5899; CCIN 576F)	142
PCIe LP 2-Port 1GbE TX Adapter (FC 9056; CCIN 5767)	145
PCIe2 LP 2-Port 10 GbE RoCE SFP+ Adapter (FC EC27 and FC EC28)	150
PCIe2 LP 2x10Gb FCoE 2x1GbE SFP+ Adapter (FC EN0J; CCIN 2B93)	152
PCIe2 LP 4-port (10 Gb FCoE and 1 GbE) Copper and RJ45 Adapter (FC EN0L; CCIN 2CC1)	154

PCIe2 LP 2-Port 10 GbE RoCE SR Adapter (FC EC29; CCIN EC29)	156
PCIe LP 2-Port 10 GbE SFN6122F Adapter (FC EC2G; CCIN EC2G)	157
PCIe 2-Port LP 10 GbE SFN5162F Adapter (FC EC2H; CCIN EC2H)	160
4-Port USB PCI Express Adapter (FC 2728; CCIN 57D1)	162
PCIe Cryptographic Coprocessor (FC 4807, FC 4808, and FC 4809; CCIN 4765)	164
PCIe2 2-port 4X InfiniBand QDR Adapter (FC 5283, FC 5285; CCIN 58E2)	166
PCIe RAID and SSD SAS adapter 3 Gb (FC 2053, FC 2055; CCIN 57CD)	167
PCIe LP Dual - x4 SAS Adapter (FC 5278; CCIN 57B3)	171
PCIe Dual - x4 3 Gb SAS RAID Adapter (FC 5903 and FC 5805; CCIN 574E)	174
PCIe Dual - x4 SAS Adapter (FC 5901; CCIN 57B3)	177
PCIe2 1.8 GB Cache RAID SAS Tri-port 6 Gb Adapter (FC 5913; CCIN 57B5)	180
PCIe2 RAID SAS Adapter Dual-port 6Gb (FC ESA1; CCIN 57C4)	184
PCIe2 RAID SAS Adapter Dual-port 6-Gb LP (FC ESA2; CCIN 57C4)	186
PCIe 2-Line WAN with Modem (FC 2893 (EN13), 2894 (EN14); CCIN 576C)	188
PCIe2 3.1GB Cache Integrated SAS RAID Adapter (CCIN 57C3) included in Feature 5888	189
IBM Flash Adapter 90 (PCIe2 0.9TB) (FC ES09; CCIN 578A)	192
Overview and specifications of the IBM Flash Adapter 90 (PCIe2 0.9TB) (FC ES09; CCIN 578A)	192
Installing the IBM Flash Adapter 90 (PCIe2 0.9TB)	194
Verifying the IBM Flash Adapter 90 (PCIe2 0.9TB) installation in an AIX logical partition	194
Verifying the IBM Flash Adapter 90 (PCIe2 0.9TB) installation in a Linux VM	195
Installing the device driver for the IBM Flash Adapter 90 (PCIe2 0.9TB)	196
Installing the device driver in an AIX system or logical partition	196
Installing the device driver in a Linux VM	196
Verifying the storage device availability	196
Verifying the storage device availability in an AIX system or logical partition	197
Verifying the storage device availability in a Linux VM	197
Formatting the IBM Flash Adapter 90 (PCIe2 0.9TB)	197
Formatting the device in an AIX system or an AIX logical partition	197
Formatting the device in a Linux VM	198
Using the IBM Flash Adapter 90 (PCIe2 0.9TB)	199
The rs_info Utility for the IBM Flash adapter 90 (PCIe2 0.9TB)	199
Verifying whether the rs_info utility is installed in an AIX system or an AIX logical partition	199
Verifying whether the rs_info utility is installed in a Linux system or Linux virtual machine	200
Installing the rs_info utility in an AIX system or an AIX logical partition	200
Installing the rs_info utility in a Linux system or Linux virtual machine	200
Running the rs_info utility in an AIX system or an AIX logical partition	202
Running the rs_info utility in a Linux system or Linux virtual machine	205
The rs_info utility fields	207
Maintaining the rechargeable battery on the 57B7, 57CF, 574E, and 572F/575C SAS adapters	208
Replacing SCSI RAID disk-controller cache battery packs	208
Replacing the cache battery pack on the 571B adapter	209
Replacing the cache battery pack on the 571F and 575B adapters	211
Replacing the cache battery pack on the 571E, 574F, 2780, or 5708 adapters	214
Replacing a battery pack	217
Replacing a 572B nonconcurrent maintainable battery pack	218
Replacing a 572F/575C card set concurrent maintainable battery pack	220
Replacing a 57B7 concurrent maintainable battery pack	221
Replacing a 57CF cache battery pack	222
Replacing a 574E concurrent maintainable battery pack	223
Displaying rechargeable battery information	224
Installing the AIX device driver software	224
Verifying the AIX device driver software	225
Notices	227
Trademarks	228
Electronic emission notices	228
Class A Notices	229
Class B Notices	232
Terms and conditions	235

Safety notices

Safety notices may be printed throughout this guide:

- **DANGER** notices call attention to a situation that is potentially lethal or extremely hazardous to people.
- **CAUTION** notices call attention to a situation that is potentially hazardous to people because of some existing condition.
- **Attention** notices call attention to the possibility of damage to a program, device, system, or data.

World Trade safety information

Several countries require the safety information contained in product publications to be presented in their national languages. If this requirement applies to your country, safety information documentation is included in the publications package (such as in printed documentation, on DVD, or as part of the product) shipped with the product. The documentation contains the safety information in your national language with references to the U.S. English source. Before using a U.S. English publication to install, operate, or service this product, you must first become familiar with the related safety information documentation. You should also refer to the safety information documentation any time you do not clearly understand any safety information in the U.S. English publications.

Replacement or additional copies of safety information documentation can be obtained by calling the IBM Hotline at 1-800-300-8751.

German safety information

Das Produkt ist nicht für den Einsatz an Bildschirmarbeitsplätzen im Sinne § 2 der Bildschirmarbeitsverordnung geeignet.

Laser safety information

IBM® servers can use I/O cards or features that are fiber-optic based and that utilize lasers or LEDs.

Laser compliance

IBM servers may be installed inside or outside of an IT equipment rack.

DANGER

When working on or around the system, observe the following precautions:

Electrical voltage and current from power, telephone, and communication cables are hazardous. To avoid a shock hazard:

- Connect power to this unit only with the IBM provided power cord. Do not use the IBM provided power cord for any other product.
- Do not open or service any power supply assembly.
- Do not connect or disconnect any cables or perform installation, maintenance, or reconfiguration of this product during an electrical storm.
- The product might be equipped with multiple power cords. To remove all hazardous voltages, disconnect all power cords.
- Connect all power cords to a properly wired and grounded electrical outlet. Ensure that the outlet supplies proper voltage and phase rotation according to the system rating plate.
- Connect any equipment that will be attached to this product to properly wired outlets.
- When possible, use one hand only to connect or disconnect signal cables.
- Never turn on any equipment when there is evidence of fire, water, or structural damage.
- Disconnect the attached power cords, telecommunications systems, networks, and modems before you open the device covers, unless instructed otherwise in the installation and configuration procedures.
- Connect and disconnect cables as described in the following procedures when installing, moving, or opening covers on this product or attached devices.

To Disconnect:

1. Turn off everything (unless instructed otherwise).
2. Remove the power cords from the outlets.
3. Remove the signal cables from the connectors.
4. Remove all cables from the devices.

To Connect:

1. Turn off everything (unless instructed otherwise).
2. Attach all cables to the devices.
3. Attach the signal cables to the connectors.
4. Attach the power cords to the outlets.
5. Turn on the devices.

(D005)

DANGER

Observe the following precautions when working on or around your IT rack system:

- Heavy equipment—personal injury or equipment damage might result if mishandled.
- Always lower the leveling pads on the rack cabinet.
- Always install stabilizer brackets on the rack cabinet.
- To avoid hazardous conditions due to uneven mechanical loading, always install the heaviest devices in the bottom of the rack cabinet. Always install servers and optional devices starting from the bottom of the rack cabinet.
- Rack-mounted devices are not to be used as shelves or work spaces. Do not place objects on top of rack-mounted devices.



- Each rack cabinet might have more than one power cord. Be sure to disconnect all power cords in the rack cabinet when directed to disconnect power during servicing.
- Connect all devices installed in a rack cabinet to power devices installed in the same rack cabinet. Do not plug a power cord from a device installed in one rack cabinet into a power device installed in a different rack cabinet.
- An electrical outlet that is not correctly wired could place hazardous voltage on the metal parts of the system or the devices that attach to the system. It is the responsibility of the customer to ensure that the outlet is correctly wired and grounded to prevent an electrical shock.

CAUTION

- Do not install a unit in a rack where the internal rack ambient temperatures will exceed the manufacturer's recommended ambient temperature for all your rack-mounted devices.
- Do not install a unit in a rack where the air flow is compromised. Ensure that air flow is not blocked or reduced on any side, front, or back of a unit used for air flow through the unit.
- Consideration should be given to the connection of the equipment to the supply circuit so that overloading of the circuits does not compromise the supply wiring or overcurrent protection. To provide the correct power connection to a rack, refer to the rating labels located on the equipment in the rack to determine the total power requirement of the supply circuit.
- *(For sliding drawers.)* Do not pull out or install any drawer or feature if the rack stabilizer brackets are not attached to the rack. Do not pull out more than one drawer at a time. The rack might become unstable if you pull out more than one drawer at a time.
- *(For fixed drawers.)* This drawer is a fixed drawer and must not be moved for servicing unless specified by the manufacturer. Attempting to move the drawer partially or completely out of the rack might cause the rack to become unstable or cause the drawer to fall out of the rack.

(R001)

CAUTION:

Removing components from the upper positions in the rack cabinet improves rack stability during relocation. Follow these general guidelines whenever you relocate a populated rack cabinet within a room or building:

- Reduce the weight of the rack cabinet by removing equipment starting at the top of the rack cabinet. When possible, restore the rack cabinet to the configuration of the rack cabinet as you received it. If this configuration is not known, you must observe the following precautions:
 - Remove all devices in the 32U position and above.
 - Ensure that the heaviest devices are installed in the bottom of the rack cabinet.
 - Ensure that there are no empty U-levels between devices installed in the rack cabinet below the 32U level.
- If the rack cabinet you are relocating is part of a suite of rack cabinets, detach the rack cabinet from the suite.
- Inspect the route that you plan to take to eliminate potential hazards.
- Verify that the route that you choose can support the weight of the loaded rack cabinet. Refer to the documentation that comes with your rack cabinet for the weight of a loaded rack cabinet.
- Verify that all door openings are at least 760 x 230 mm (30 x 80 in.).
- Ensure that all devices, shelves, drawers, doors, and cables are secure.
- Ensure that the four leveling pads are raised to their highest position.
- Ensure that there is no stabilizer bracket installed on the rack cabinet during movement.
- Do not use a ramp inclined at more than 10 degrees.
- When the rack cabinet is in the new location, complete the following steps:
 - Lower the four leveling pads.
 - Install stabilizer brackets on the rack cabinet.
 - If you removed any devices from the rack cabinet, repopulate the rack cabinet from the lowest position to the highest position.
- If a long-distance relocation is required, restore the rack cabinet to the configuration of the rack cabinet as you received it. Pack the rack cabinet in the original packaging material, or equivalent. Also lower the leveling pads to raise the casters off of the pallet and bolt the rack cabinet to the pallet.

(R002)

(L001)



(L002)



(L003)

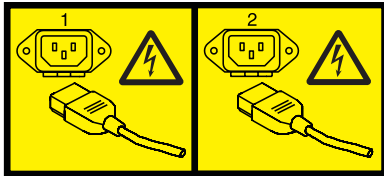

or



All lasers are certified in the U.S. to conform to the requirements of DHHS 21 CFR Subchapter J for class 1 laser products. Outside the U.S., they are certified to be in compliance with IEC 60825 as a class 1 laser product. Consult the label on each part for laser certification numbers and approval information.

CAUTION:

This product might contain one or more of the following devices: CD-ROM drive, DVD-ROM drive, DVD-RAM drive, or laser module, which are Class 1 laser products. Note the following information:

- Do not remove the covers. Removing the covers of the laser product could result in exposure to hazardous laser radiation. There are no serviceable parts inside the device.
- Use of the controls or adjustments or performance of procedures other than those specified herein might result in hazardous radiation exposure.

(C026)

CAUTION:

Data processing environments can contain equipment transmitting on system links with laser modules that operate at greater than Class 1 power levels. For this reason, never look into the end of an optical fiber cable or open receptacle. (C027)

CAUTION:

This product contains a Class 1M laser. Do not view directly with optical instruments. (C028)

CAUTION:

Some laser products contain an embedded Class 3A or Class 3B laser diode. Note the following information: laser radiation when open. Do not stare into the beam, do not view directly with optical instruments, and avoid direct exposure to the beam. (C030)

CAUTION:

The battery contains lithium. To avoid possible explosion, do not burn or charge the battery.

Do Not:

- ___ Throw or immerse into water
- ___ Heat to more than 100°C (212°F)
- ___ Repair or disassemble

Exchange only with the IBM-approved part. Recycle or discard the battery as instructed by local regulations. In the United States, IBM has a process for the collection of this battery. For information, call 1-800-426-4333. Have the IBM part number for the battery unit available when you call. (C003)

Power and cabling information for NEBS (Network Equipment-Building System) GR-1089-CORE

The following comments apply to the IBM servers that have been designated as conforming to NEBS (Network Equipment-Building System) GR-1089-CORE:

The equipment is suitable for installation in the following:

- Network telecommunications facilities
- Locations where the NEC (National Electrical Code) applies

The intrabuilding ports of this equipment are suitable for connection to intrabuilding or unexposed wiring or cabling only. The intrabuilding ports of this equipment *must not* be metallically connected to the interfaces that connect to the OSP (outside plant) or its wiring. These interfaces are designed for use as intrabuilding interfaces only (Type 2 or Type 4 ports as described in GR-1089-CORE) and require isolation from the exposed OSP cabling. The addition of primary protectors is not sufficient protection to connect these interfaces metallically to OSP wiring.

Note: All Ethernet cables must be shielded and grounded at both ends.

The ac-powered system does not require the use of an external surge protection device (SPD).

The dc-powered system employs an isolated DC return (DC-I) design. The DC battery return terminal *shall not* be connected to the chassis or frame ground.

Managing PCI adapters for the 8231-E2B, 8231-E1C, 8231-E1D, 8231-E2C, 8231-E2D, or 8268-E1D

Learn about using and managing the peripheral component interconnect (PCI), PCI-X, and PCI Express (PCIe) adapters that are supported for the IBM Power® 710 Express (8231-E2B, 8231-E1C, 8231-E1D, or 8268-E1D) and the IBM Power 730 Express (8231-E2B, 8231-E2C, or 8231-E2D) systems. You can learn about the specifications and instructions for specific adapters.

The following features are electromagnetic compatibility (EMC) Class B features. See the Class B Notices in the Hardware Notices section.

Table 1. Electromagnetic compatibility (EMC) Class B features

Feature	Description
1912, 5736	PCI-X DDR 2.0 Dual Channel Ultra320 SCSI Adapter
1983, 5706	Port 10/100/1000 Base-TX Ethernet PCI-X Adapter
1986, 5713	1 Gb iSCSI TOE PCI-X Adapter
2728	4-port USB PCIe Adapter
4764	PCI-X Cryptographic Coprocessor
4807	PCIe Cryptographic Coprocessor
5717	4-port 10/100/1000 Base-TX PCI Express Adapter
5732	10 Gb Ethernet-CX4 PCI Express Adapter
5748	POWER® GXT145 PCI Express Graphics Accelerator
5767	2-port 10/100/1000 Base-TX Ethernet PCI Express Adapter
5768	2-port Gb Ethernet-SX PCI Express Adapter
5769	10 Gb Ethernet-SR PCI Express Adapter
5772	10 Gb Ethernet-LR PCI Express Adapter
5785	4 Port Async EIA-232 PCIe Adapter
EC2G and EL39	PCIe LP 2-Port 10 GbE SFN6122F Adapter
EC2H and EL3A	PCIe LP 2-Port 10 GbE SFN5162F Adapter
EC2J	PCIe 2-Port 10 GbE SFN6122F Adapter
EC2K	PCIe 2-Port 10 GbE SFN5162F Adapter

Related information:



Adapters, Devices, and Cable Information for Multiple Bus Systems (SA38-0516)

Information about older adapters that are not covered in Managing PCI adapters, and that were announced before October 2003.

Overview of managing PCI adapters

Learn how to use and manage Peripheral Component Interconnect (PCI) adapters. Find specifications and instructions for specific adapters.

The following features are electromagnetic compatibility (EMC) Class B features. See the Class B Notices in the Hardware Notices section.

Table 2. Electromagnetic compatibility (EMC) Class B features

Feature	Description
1912, 5736	PCI-X DDR 2.0 Dual Channel Ultra320 SCSI Adapter
1983, 5706	Port 10/100/1000 Base-TX Ethernet PCI-X Adapter
1986, 5713	1 Gb iSCSI TOE PCI-X Adapter
2728	4-port USB PCIe Adapter
4764	PCI-X Cryptographic Coprocessor
4807	PCIe Cryptographic Coprocessor
5717	4-port 10/100/1000 Base-TX PCI Express Adapter
5732	10 Gb Ethernet-CX4 PCI Express Adapter
5748	POWER GXT145 PCI Express Graphics Accelerator
5767	2-port 10/100/1000 Base-TX Ethernet PCI Express Adapter
5768	2-port Gb Ethernet-SX PCI Express Adapter
5769	10 Gb Ethernet-SR PCI Express Adapter
5772	10 Gb Ethernet-LR PCI Express Adapter
5785	4 Port Async EIA-232 PCIe Adapter
EC2G and EL39	PCIe LP 2-Port 10 GbE SFN6122F Adapter
EC2H and EL3A	PCIe LP 2-Port 10 GbE SFN5162F Adapter
EC2J	PCIe 2-Port 10 GbE SFN6122F Adapter
EC2K	PCIe 2-Port 10 GbE SFN5162F Adapter

The adapter information that is shown here is used during non-directed service activities. The information can be used to:

- Identify an adapter
- Find specific technical information about an adapter
- Where applicable, show special installation or cabling instructions
- Show signal names for the output-pins of the adapter connectors
- Where applicable, show the settings for switches or jumpers

Adapters can be identified by their feature code (FC) or their custom-card identification number (CCIN). Normally, the CCIN number is labeled on the adapter.

The FRU part number (P/N) of your adapter might not match the FRU P/N listed in this information. If the part numbers do not match, verify that the CCIN is the same. If the CCIN is same, the adapter has the same function and can be used in the same way.

Adapters must be placed in specific peripheral component interconnect (PCI), PCI-X, or PCI Express (PCIe) slots to function correctly or optimally. See the PCI adapter placement for system-specific information about which slots are available and which adapters can be placed in those slots.

Backplane daughter cards and RAID enablement cards

Find links to topics that cover Backplane daughter cards and RAID enablement cards.

Backplane daughter cards and RAID enablement cards that are not in the PCI form factor are not described in the Managing PCI adapters information.

See Parts Information to find part numbers and location codes for these types of cards.

See the following sections for SAS RAID enablement procedures:

- SAS RAID controllers for AIX®
- SAS RAID controllers for IBM i
- SAS RAID controllers for Linux

Related reference:

 Parts information

PCI Express

Learn about PCI Express (PCIe) adapters and slots.

PCI Express (PCIe) adapters use a different type of slot than Peripheral Component Interconnect (PCI) and Peripheral Component Interconnect-X (PCI-X) adapters. If you attempt to force an adapter into the wrong type of slot, you might damage the adapter or the slot. A PCI adapter can be installed in a PCI-X slot, and a PCI-X adapter can be installed in a PCI adapter slot. A PCIe adapter cannot be installed in a PCI or PCI-X adapter slot, and a PCI or PCI-X adapter cannot be installed in a PCIe slot. The following illustration shows an example of a PCI-X adapter (**A**) next to a PCIe 4x (**B**) adapter.

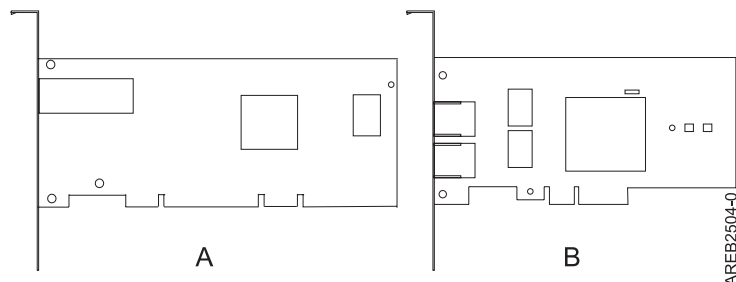

Figure 1. PCI-X adapter and PCIe 4x adapter

PCIe adapters and slots come in 4 different sizes: 1x, 4x, 8x, and 16x. Smaller size adapters do fit in larger slots, but larger size adapters do not fit in smaller slots. The following table shows PCIe slot compatibility.

Table 3. PCIe slot compatibility

	1x slot	4x slot	8x slot	16x slot
1x adapter	Supported	Supported	Supported	Supported
4x adapter	Not supported	Supported	Supported	Supported
8x adapter	Not supported	Not supported	Supported	Supported
16x adapter	Not supported	Not supported	Not supported	Supported

To learn more about the PCIe standard, see the IBM Redbooks® technote: Introduction to PCI Express.

Handling static sensitive devices

Electronic boards, adapters, media drives, and disk drives are sensitive to static electricity discharge. These devices are wrapped in antistatic bags to prevent damage. Learn about taking precautions to prevent damage to these devices from static electricity discharge.

- Attach a wrist strap to an unpainted metal surface of your hardware to prevent electrostatic discharge from damaging your hardware.
- When using a wrist strap, follow all electrical safety procedures. A wrist strap is for static control. It does not increase or decrease your risk of receiving electric shock when using or working on electrical equipment.

- If you do not have a wrist strap, before removing the product from ESD packaging and installing or replacing hardware, touch an unpainted metal surface of the system for a minimum of 5 seconds.
- Do not remove the device from the antistatic bag until you are ready to install the device in the system.
- With the device still in its antistatic bag, touch it to the metal frame of the system.
- Grasp cards and boards by the edges. Avoid touching the components and gold-edge connectors on the adapter.
- If you need to lay the device down while it is out of the antistatic bag, lay it on the antistatic bag. Before picking it up again, touch the antistatic bag and the metal frame of the system at the same time.
- Handle the devices carefully to prevent permanent damage.

Important partitioning considerations with dual-slot and multi-adapter configurations

Learn about partitioning considerations with dual-slot and multi-adapter configurations.

Logical partitions can own physical I/O resources. Physical I/O resources are assigned to logical partitions at the slot level. Assigning a slot to a logical partition enables the operating system that runs in the logical partition to control the functionality of the I/O resource and power for that slot. When the operating system powers a slot on or off, the physical I/O resource is powered on or off.

In some I/O configurations, the functionality of an adapter or I/O resource depends on two or more physical slots. For example, if you have a double-wide RAID adapter (FC 2053, 2054, or 2055) that take up two adjacent adapter slots or two separate RAID adapters paired together, both physical slots must be assigned to the same logical partition. For example, if you install the FC 2053, 2054, or 2055 adapter in slot 2, then the adjacent slot 3 cannot be used to install another adapter even though the slot 3 is reported as empty. It is important to understand the wanted configuration and function being provided before completing the logical partitioning and activation of the resources involved.

There are two I/O configurations involving adapter pairs:

- Multi-initiator and high availability
- Auxiliary Write Cache

Multi-initiator and high availability

The terms multi-initiator and high availability (HA) refer to connecting multiple adapters (typically two adapters) to a common set of disk expansion drawers for increasing availability. This configuration is also referred to as Dual Storage IOA configuration. This type of connection is commonly done in either of the following configurations:

Note: Some systems have SAS RAID adapters integrated onto the system boards and use a Cache RAID - Dual IOA Enablement Card (FC 5662) to enable storage adapter Write Cache and Dual Storage IOA (HA RAID Mode). For these configurations, installation of the Cache RAID - Dual IOA Enablement Card places the two integrated adapters into a HA RAID configuration. There are no separate SAS cables required to connect the two integrated SAS RAID adapters to each other.

HA two-system configuration

An HA two-system configuration provides a high-availability environment for system storage by enabling two systems or partitions to have access to the same set of disks and disk arrays. This feature is typically used with the IBM PowerHA[®] SystemMirror[®]. The IBM PowerHA SystemMirror software provides a commercial computing environment that ensures that mission-critical applications can recover quickly from hardware and software failures. The support for this configuration is operating system dependent.

HA single system configuration

An HA single system configuration provides for redundant adapters from a single system to the same set of disks and disk arrays. This feature is typically referred to as Multi-Path I/O (MPIO). MPIO support is part of the operating system support and can be used to provide a redundant IBM SAS RAID controller configuration with RAID protected disks.

Auxiliary write cache adapter

The auxiliary write cache (AWC) adapter provides a duplicate, nonvolatile copy of write cache data of the RAID controller to which it is connected.

Protection of data is enhanced by having two battery-backed (nonvolatile) copies of write cache, each stored on separate adapters. If a failure occurs to the write cache portion of the RAID controller, or the RAID controller itself fails in such a way that the write cache data is not recoverable, the AWC adapter provides a backup copy of the write cache data to prevent data loss during the recovery of the failed RAID controller. The cache data is recovered to the new replacement RAID controller and then written out to disk before resuming normal operations.

The AWC adapter is not a failover device that can keep the system operational by continuing disk operations when the attached RAID controller fails. The system cannot use the auxiliary copy of the cache for runtime operations even if only the cache on the RAID controller fails. The AWC adapter does not support any other device attachment and performs no other tasks than communicating with the attached RAID controller to receive backup write cache data. The purpose of the AWC adapter is to minimize the length of an unplanned outage, due to a failure of a RAID controller, by preventing loss of critical data that might have otherwise required a system reload.

It is important to understand the difference between multi-initiator connections and AWC connections. Connecting controllers in a multi-initiator environment refers to multiple RAID controllers connected to a common set of disk enclosures and disks. The AWC controller is not connected to the disks, and it does not perform device media accesses.

The RAID controller and the AWC adapter each require a PCI bus connection and are required to be in the same partition. The two adapters are connected by an internal connection. For the planar RAID enablement and planar auxiliary cache features, the dedicated connection is integrated into the system planar.

Related tasks:

Serial-attached SCSI cable planning

Learn about how to install the SAS cables to the hard disk drives or solid-state drives.

Related reference:

“PCIe RAID and SSD SAS adapter 3 Gb (FC 2053, FC 2055; CCIN 57CD)” on page 167

Learn about the specifications and operating system requirements for the feature code (FC) 2053 or 2055 adapter.

“PCIe Dual - x4 3 Gb SAS RAID Adapter (FC 5903 and FC 5805; CCIN 574E)” on page 174

Learn about the specifications and operating system requirements for the feature code (FC) 5903 and FC 5805 adapters.

“PCIe2 1.8 GB Cache RAID SAS Tri-port 6 Gb Adapter (FC 5913; CCIN 57B5)” on page 180

Learn about the specifications and operating system requirements for the feature code (FC) 5913 adapters.

“PCIe2 RAID SAS Adapter Dual-port 6Gb (FC ESA1; CCIN 57C4)” on page 184

Learn about the specifications and operating system requirements for the feature code (FC) ESA1 adapters.

“PCIe2 RAID SAS Adapter Dual-port 6-Gb LP (FC ESA2; CCIN 57C4)” on page 186

Learn about the specifications and operating system requirements for the feature code (FC) ESA2

adapters.

“PCIe2 3.1GB Cache Integrated SAS RAID Adapter (CCIN 57C3) included in Feature 5888” on page 189
Learn about the specifications and operating system requirements for the PCIe2 3.1GB Cache Integrated SAS RAID adapter that is integrated with the EXP30 Ultra SSD I/O Drawer (feature code 5888 PCIe storage enclosure). The adapter reports as PCIe2 3.1GB Cache RAID SAS Enclosure 6Gb x8.

Related information:

 Logical partitioning

Information about logical partitioning.

 Changing partition profile properties

Information about changing partition profile properties by using the HMC.

Dual IOA Enablement Card (FC 5662)

Information about the specifications for the Dual IOA Enablement Card.

SAS RAID controllers for AIX

Information about usage and maintenance information for the SAS RAID Controller for the AIX.

SAS RAID controllers for IBM i

Information about usage and maintenance information for the SAS RAID Controller for the IBM i.

SAS RAID controllers for Linux

Information about the usage and maintenance information for the SAS RAID Controller for Linux.

PCI adapter information by feature type for the 8231-E2B, 8231-E1C, 8231-E1D, 8231-E2C, 8231-E2D, or 8268-E1D

Find technical information for specific adapters supported on your system. Adapters can be identified by their feature code (FC) or their custom card identification number (CCIN).

Related tasks:

 Installing PCI adapters

Related reference:

 IBM Prerequisite website

 Parts information

 PCI adapter placement

“Backplane daughter cards and RAID enablement cards” on page 2

Find links to topics that cover Backplane daughter cards and RAID enablement cards.

Related information:

 Adapters, Devices, and Cable Information for Multiple Bus Systems (SA38-0516)

Information about older adapters that are not covered in Managing PCI adapters, and that were announced before October 2003.

PCIe LP 4-Port Async EIA-232 Adapter (FC 5277; CCIN 57D2)

Learn about the features, operating system requirements, and installation procedures for the feature code (FC) 5277 adapters.

Overview

The FC 5277 (PCIe LP 4-Port Async EIA-232 Adapter) is the low-profile version of the FC 5785 (4 Port Async EIA-232 PCIe adapter), which is a full-height adapter.

The PCIe LP 4-Port Async EIA-232 Adapter provides connections for four asynchronous EIA-232 devices using a 4-port DB-9F DTE fan-out cable. Ports are programmable to support EIA-232 protocols at a line speed of 128 Kbps.

The following figures show the adapter and cable.

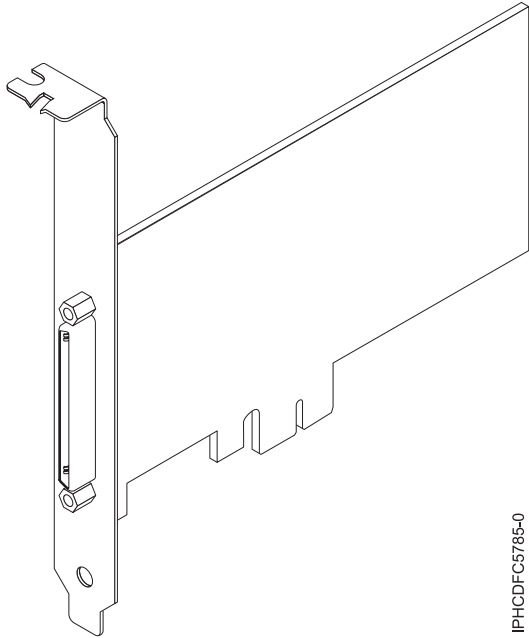

Figure 2. Adapter

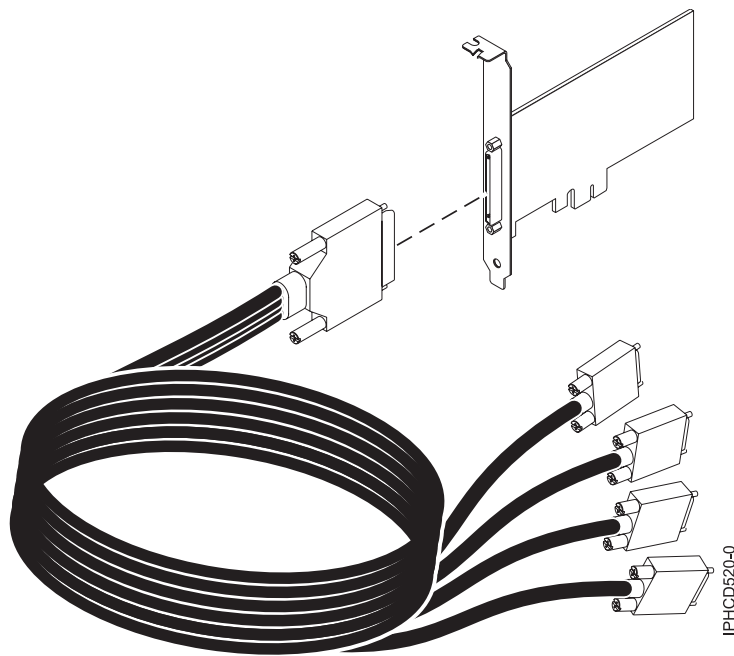

Figure 3. Cable

Specifications

Item	Description
------	-------------

FRU number

Adapter: 46K6734*

Cable: 46K6735*

*Designed to comply with RoHS requirement.

I/O bus architecture

PCIe-V1.0a 1x

Busmaster

No

Maximum number

For the maximum adapters supported, see the PCI adapter placement topic collection for your system.

Adapter size

PCIe 1x, short form factor

Connectors

Adapter: 68-pin SCSI

Cable: 68-pin SCSI to DB 9-pin shell

Wrap plug

42R5143

For details about slot priorities and placement rules, see the PCI adapter placement topic collection for your system.

Operating system or partition requirements

If you are installing a new feature, ensure that you have the software that is required to support the new feature and that you determine whether there are any prerequisites for this feature and attaching devices. To check for the prerequisites, see IBM Prerequisite website (www-912.ibm.com/e_dir/eServerPrereq.nsf).

The adapter is supported on the following versions of the operating system:

- AIX:
 - AIX 7.1, or later
 - AIX 6.1, or later
 - AIX 5L™ Version 5.3 with the 5300-07 Technology Level, or laterThe AIX device package name is `devices.pci.1410a803.rte`.

The adapter is supported on the following operating system:

- Linux:
 - SUSE Linux Enterprise Server 11, or later
 - Red Hat Enterprise Linux version 5.3, or later
- IBM i
 - IBM i 7.3, or later
 - IBM i 7.2 TR4, or later
 - IBM i 7.1 TR11, or later

Preparing for installation

If you are installing your operating system at this time, install your adapter before you install the operating system. If you are installing only the device driver for this adapter, install your device driver software before you install the adapter.

Installing the AIX device driver software

To install device driver software, follow the steps in “Installing the AIX device driver software” on page 224.

Installing the adapter

For general instructions on how to install a PCI adapter, see the Installing PCI adapters topic. Return here to verify the adapter installation.

Verifying the adapter installation

To verify that your system unit recognizes the PCI adapter, do the following steps:

1. If necessary, log in as root user.
2. At the command line, type: `lsdev -Cs pci`
3. Press Enter.

A list of PCI devices is displayed. If the adapter is installed correctly, the status of available for each port indicates that the adapter is installed and ready to use. If a message indicates that any of the ports are defined instead of available, shut down your server and verify that the adapter was installed correctly.

Related tasks:

[Installing PCI adapters](#)

Related reference:

[IBM Prerequisite website](#)

[Parts information](#)

[PCI adapter placement](#)

“Backplane daughter cards and RAID enablement cards” on page 2

Find links to topics that cover Backplane daughter cards and RAID enablement cards.

PCIe 2-port Async EIA-232 Adapter (FC 5289; CCIN 57D4)

Learn about the specifications and operating system requirements for the feature code (FC) 5289 adapters.

Overview

FC 5289 and 5290 are both the same adapter. FC 5289 is a full-height adapter, and the FC 5290 is a low-profile adapter. The names of these two adapters are:

- FC 5289: PCIe 2-port Async EIA-232 Adapter
- FC 5290: PCIe LP 2-port Async EIA-232 Adapter (tailstock only)

The FC 5289 and FC 5290 are 2-port EIA-232 asynchronous serial communications PCI Express (PCIe) adapters that can be installed in the PCIe slots. The adapters are based on the PCIe 1.1 host bus interface. The parallel port function is not implemented on these adapters.

Each of the two Universal Asynchronous Receiver/Transmitter (UART) channels contain 128 byte receiver-transmitter, first-in first-out (FIFO), full modem-control signaling, and standard host interrupts. If either of the two UART interrupts are active, the host can be interrupted through a single PCI interrupt. The two-port adapter provides RJ45 Ethernet ports, which are connected by DB-9 connectors.

For details about slot priorities and placement rules, see the PCI adapter placement topic collection for your system.

Specifications

Item Description

Adapter FRU number

74Y4084 (Designed to comply with RoHS requirement)

I/O bus architecture

PCIe 1.1

Slot requirement

For the slot priorities, see the PCI adapter placement topic collection for your system.

Cables

Cat 5 unshielded twisted-pair cables

Voltage

3.3 V

Form factor

Short

Maximum number

For the maximum adapters supported, see the PCI adapter placement topic collection for your system.

Operating system or partition requirements

This adapter is supported for the following versions of the operating systems:

- AIX:
 - AIX 7.1 with the 7100-01 Technology Level, or later
 - AIX 6.1 with the 6100-07 Technology Level, or later
 - AIX 5.3 with the 5300-12 Technology Level, and Service Pack 5, or later
- Linux:
 - SUSE Linux Enterprise Server 11 SP1, or later
 - SUSE Linux Enterprise Server 10 SP4, or later
 - Red Hat Enterprise Linux Version 6.1, or later
 - Red Hat Enterprise Linux Version 5.7, or later
 - See the Linux Alert site for the support details.

Related tasks:

[Installing PCI adapters](#)

Related reference:

[IBM Prerequisite website](#)

[Parts information](#)

[PCI adapter placement](#)

“Backplane daughter cards and RAID enablement cards” on page 2

Find links to topics that cover Backplane daughter cards and RAID enablement cards.

PCIe LP 2-port Async EIA-232 Adapter (FC 5290; CCIN 57D4)

Learn about the specifications and operating system requirements for the feature code (FC) 5290 adapters.

Overview

FC 5289 and 5290 are both the same adapter. FC 5289 is a full-height adapter, and the FC 5290 is a low-profile adapter.

The FC 5289 and FC 5290 are 2-port EIA-232 asynchronous serial communications PCI Express (PCIe) adapters that can be installed in the PCIe slots. The adapters are based on the PCIe 1.1 host bus interface. The parallel port function is not implemented on these adapters.

Each of the two universal asynchronous receiver/transmitter (UART) channels contain 128 byte receiver-transmitter, first-in first-out (FIFO), full modem-control signaling, and standard host interrupts. If either of the two UART interrupts are active, the host can be interrupted through a single PCI interrupt. The two-port adapter provides RJ45 Ethernet ports, which are connected by DB-9 connectors.

For details about slot priorities and placement rules, see the PCI adapter placement topic collection for your system.

Specifications

Item Description

Adapter FRU number

74Y4085 (Designed to comply with RoHS requirement)

I/O bus architecture

PCIe 1.1

Slot requirement

For the slot priorities, see the PCI adapter placement topic collection for your system.

Cables

Cat 5 unshielded twisted-pair cables

Voltage

3.3 V

Form factor

Short

Maximum number

For the maximum adapters supported, see the PCI adapter placement topic collection for your system.

Operating system or partition requirements

This adapter is supported for the following versions of the operating systems:

- AIX:
 - AIX 7.1 with the 7100-01 Technology Level, or later
 - AIX 6.1 with the 6100-07 Technology Level, or later
 - AIX 5.3 with the 5300-12 Technology Level, and Service Pack 5, or later
- Linux:
 - SUSE Linux Enterprise Server 11 SP1, or later
 - SUSE Linux Enterprise Server 10 SP4, or later
 - Red Hat Enterprise Linux Version 6.1, or later
 - Red Hat Enterprise Linux Version 5.7, or later
 - For support details, see the Linux Alert website (www14.software.ibm.com/webapp/set2/sas/f/lopdiags/info/LinuxAlerts.htm)
- IBM i:
 - IBM i Version 7.1, or later

If you are installing a new feature, ensure that you have the software that is required to support the new feature and that you determine whether there are any prerequisites for this feature and attaching devices. To check for the prerequisites, see IBM Prerequisite website (www-912.ibm.com/e_dir/eServerPrereq.nsf).

Related tasks:

 [Installing PCI adapters](#)

Related reference:

[IBM Prerequisite website](#)

[Parts information](#)

[PCI adapter placement](#)

“Backplane daughter cards and RAID enablement cards” on page 2

Find links to topics that cover Backplane daughter cards and RAID enablement cards.

4-port Async EIA-232 PCIe Adapter (FC 5785; CCIN 57D2)

Learn about the features, operating system requirements, and installation procedures for the feature code (FC) 5785 adapters.

Overview

The FC 5785 is the is full-height adapter similar to FC 5277 (PCIe LP 4-port Async EIA-232 adapter), which is the low-profile adapter.

The 4-port Async EIA-232 PCIe Adapter provides connections for four asynchronous EIA-232 devices using a 4-port DB-9F DTE fan-out cable. Ports are programmable to support EIA-232 protocols at a line speed of 128 Kbps.

The following figures show the adapter and cable.

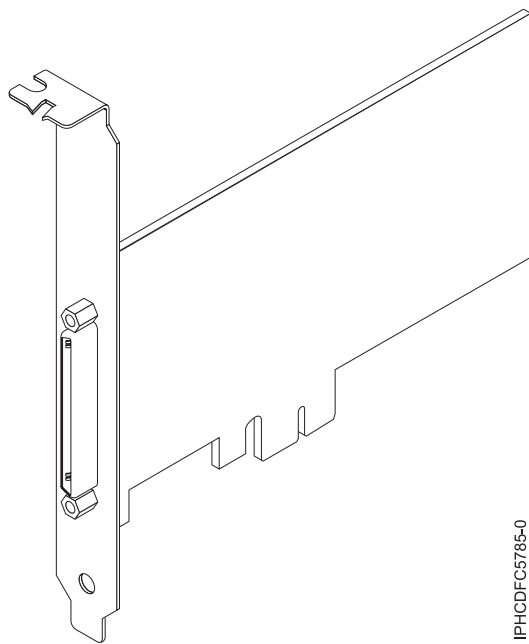

Figure 4. Adapter

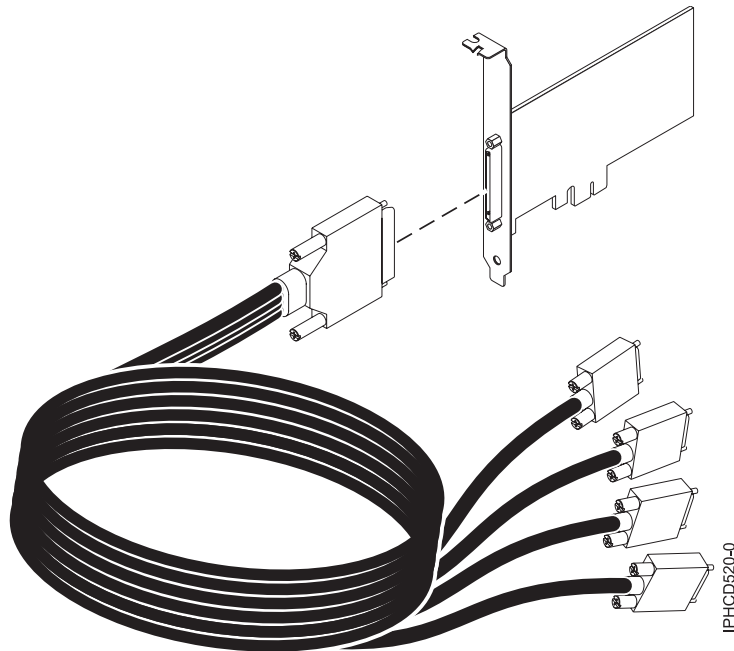

Figure 5. Cable

Specifications

Item Description

FRU number

Adapter: 46K6734*

Cable: 46K6735*

*Designed to comply with RoHS requirement.

I/O bus architecture

PCIe-V1.0a 1x

Busmaster

No

Maximum number

For the maximum adapters supported, see the PCI adapter placement topic collection for your system.

Adapter size

PCIe 1x, short form factor

Connectors

Adapter: 68-pin SCSI

Cable: 68-pin SCSI to DB 9-pin shell

Wrap plug

42R5143

For details about slot priorities and placement rules, see the PCI adapter placement topic collection for your system.

Operating system or partition requirements

If you are installing a new feature, ensure that you have the software that is required to support the new feature and that you determine whether there are any prerequisites for this feature and attaching devices. To check for the prerequisites, see IBM Prerequisite website (www-912.ibm.com/e_dir/eServerPrereq.nsf).

The adapter is supported on the following operating systems:

- AIX:
 - AIX 7.1, or later
 - AIX 6.1, or later
 - AIX 5L Version 5.3 with the 5300-07 Technology Level, or laterThe AIX device package name is `devices.pci.1410a803.rte`.
- Linux:
 - SUSE Linux Enterprise Server 11, or later
 - Red Hat Enterprise Linux Version 5.3, or later

Preparing for installation

If you are installing your operating system at this time, install your adapter before you install the operating system. If you are installing only the device driver for this adapter, install your device driver software before you install the adapter.

Installing the AIX device driver software

To install device driver software, follow the steps in “Installing the AIX device driver software” on page 224.

Installing the adapter

For general instructions on how to install a PCI adapter, see the Installing PCI adapters topic. Return here to verify the adapter installation.

Verifying the adapter installation

To verify that your system unit recognizes the PCI adapter, do the following steps:

1. If necessary, log in as root user.
2. At the command line, type: `lsdev -Cs pci`
3. Press Enter.

A list of PCI devices is displayed. If the adapter is installed correctly, the status of available for each port indicates that the adapter is installed and ready to use. If a message indicates that any of the ports are defined instead of available, shut down your server and verify that the adapter was installed correctly.

Related tasks:

“Installing the AIX device driver software” on page 224

Learn how to install the AIX device driver software for a PCI adapter.

“Verifying the AIX device driver software” on page 225

Learn how to verify the AIX device driver is installed for a PCI adapter.

 [Installing PCI adapters](#)

Related reference:

 [IBM Prerequisite website](#)

 [Parts information](#)

 [PCI adapter placement](#)

“Backplane daughter cards and RAID enablement cards” on page 2

Find links to topics that cover Backplane daughter cards and RAID enablement cards.

PCIe LP 8 Gb 2-Port Fibre Channel Adapter (FC 5273 and FC EL2N; CCIN 577D)

Learn about the specifications and operating system requirements for the feature codes (FCs) 5273 and EL2N adapters.

Overview

The PCIe LP 8 Gb 2-Port Fibre Channel Adapter is a high-performance adapter based on the Emulex LPe12002 PCIe Host Bus Adapter (HBA). The FCs 5273 is a full-height adapter. Each port provides single initiator capability over a fiber link. The ports have LC type connectors that use shortwave laser optics. The adapter connects to Fibre Channel switches and direct attached storage devices, operating at link speeds of 2, 4, and 8 Gbps. The adapter automatically negotiates with the switch to the highest speed that the switch is capable of. LEDs on each port provide information about the status and link speed of the port.

N_Port ID Virtualization (NPIV) capability is supported through Virtual I/O Server (VIOS).

The following figure shows the adapter:

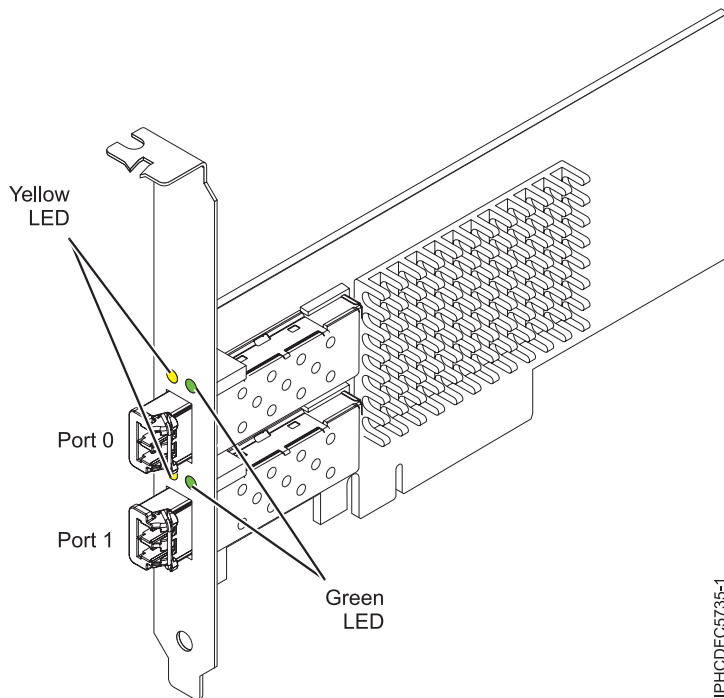

Figure 6. 5273 adapter

For details about slot priorities and placement rules, see the PCI adapter placement topic collection for your system.

Adapter specifications

Item	Description
------	-------------

FRU number	
-------------------	--

	10N9824 (Designed to comply with RoHS requirement)
--	--

Wrap plug FRU number	
-----------------------------	--

	12R9314 (Designed to comply with RoHS requirement)
--	--

	11P3847 (Not designed to comply with RoHS requirement)
--	--

I/O bus architecture

PCI Express (PCIe) Base and Card Electromechanical (CEM) 2.0
x8 PCIe bus interface

Slot requirement

One available PCIe x8 or x16 slot

Voltage

3.3 V

Form factor

Short, low-profile with standard-size bracket

FC compatibility

2, 4, 8 Gigabit

Cables

Cables are the responsibility of the customer. Use multimode fiber optic cables with shortwave lasers that adhere to the following specifications:

- OM3: Multimode 50/125 micron fiber, 2000 MHz x km bandwidth
- OM2: Multimode 50/125 micron fiber, 500 MHz x km bandwidth
- OM1: Multimode 62.5/125 micron fiber, 200 MHz x km bandwidth

Because core sizes are different, OM1 cables can only be connected to other OM1 cables. For best results, OM2 cables should not be connected to OM3 cables. However, if an OM2 cable is connected to an OM3 cable, the characteristics of the OM2 cable apply to the entire length of the cables.

The following table shows the supported distances for the three different cable types at the three different link speeds.

Table 4. Supported distances for cables

Header	Cable Type and Distance		
	OM1	OM2	OM3
Rate			
2.125 Gbps	0.5 meters to 150 meters (1.64 feet to 492.12 feet)	0.5 meters to 300 meters (1.64 feet to 984.25 feet)	0.5 meters to 500 meters (1.64 feet to 1640.41 feet)
4.25 Gbps	0.5 meters to 70 meters (1.64 feet to 229.65 feet)	0.5 meters to 150 meters (1.64 feet to 492.12 feet)	0.5 meters to 380 meters (1.64 feet to 1246.71 feet)
8.5 Gbps	0.5 meters to 21 meters (1.64 feet to 68.89 feet)	0.5 meters to 50 meters (1.64 feet to 164.04 feet)	0.5 meters to 150 meters (1.64 feet to 492.12 feet)

Maximum number

For the maximum adapters supported, see the PCI adapter placement topic collection for your system.

Operating system or partition requirements

If you are installing a new feature, ensure that you have the software that is required to support the new feature and that you determine whether there are any prerequisites for this feature and attaching devices. To check for the prerequisites, see IBM Prerequisite website (www-912.ibm.com/e_dir/eServerPrereq.nsf).

The adapter is supported on the following versions of the operating systems:

- AIX
 - AIX Version 7.1, or later
 - AIX Version 6.1, or later
 - AIX Version 5.3, or later
- Linux
 - Red Hat Enterprise Linux 6.1 for POWER, or later
 - SUSE Linux Enterprise Server 11, Service Pack 1, or later (with update package)

- See the Linux Alert site for the support details.
- IBM i
 - IBM i 7.1, or later.
 - IBM i 6.1, or later.

Adapter LED

Green and yellow LEDs can be seen through openings in the mounting bracket of the adapter. Green indicates firmware operation and yellow signifies port activity. Table 5 summarizes the link rate conditions. There is a 1-second pause when the LED is off between each group of fast flashes (2, 3, or 4). Observe the LED sequence for several seconds to be sure that you have correctly identified the state.

Table 5. Normal LED states

Green LED	Yellow LED	State
Slow flash	Off	Normal, link inactive or not started
On	2 fast flashes	2 Gbps link rate - normal, link active
On	3 fast flashes	4 Gbps link rate - normal, link active
On	4 fast flashes	8 Gbps link rate - normal, link active

Power-on self test (POST) conditions and results are summarized in Table 6. These states can be used to identify abnormal states or problems. Follow the action to be taken for each condition.

Table 6. POST conditions and results

Green LED	Yellow LED	State	Action to be taken
Off	Off	Wake-up failure (dead board)	Perform AIX, Linux or IBM i operating system diagnostics procedure.
Off	On	POST failure (dead board)	Perform AIX, Linux or IBM i operating system diagnostics procedure.
Off	Slow flash	Wake-up failure monitor	Perform AIX, Linux or IBM i operating system diagnostics procedure.
Off	Fast flash	POST failure	Perform AIX, Linux or IBM i operating system diagnostics procedure.
Off	Flashing	POST processing in progress	None
On	Off	Failure while functioning	Perform AIX, Linux or IBM i operating system diagnostics procedure.
On	On	Failure while functioning	Perform AIX, Linux or IBM i operating system diagnostics procedure.
Slow flash	Slow flash	Offline for download	None
Slow flash	Fast flash	Restricted offline mode, waiting for restart	None
Slow flash	Flashing	Restricted offline mode, test active	None

Replacing Fibre Channel adapters by using hot swap

When hot swapping Fibre Channel adapters, be aware that device-related software for the storage devices might have additional devices (for example, the disk array router (dar) device associated with the fiber array storage technology (FAST) or DS4800) that need to be removed. See the specific storage device documentation for information about how to remove these additional devices.

The new adapter has a unique worldwide port name (WWPN). Check the zoning and logical unit number (LUN) assignments to ensure that the new adapter functions as expected.

Related tasks:

[🔗 Installing PCI adapters](#)

Related reference:

[🔗 IBM Prerequisite website](#)

[🔗 Parts information](#)

[🔗 PCI adapter placement](#)

“Backplane daughter cards and RAID enablement cards” on page 2

Find links to topics that cover Backplane daughter cards and RAID enablement cards.

4 Gigabit PCI Express Dual Port Fibre Channel Adapter (FC 5276; CCIN 5774)

Learn about the specifications and operating system requirements for the feature code (FC) 5776 adapter.

Overview

The FC 5276 (4 Gigabit PCIe Dual Port Fibre Channel Adapter) is the low-profile adapter same as the FC 5774, which is the regular height adapter. The names of the two adapters are:

- FC 5276: 4 Gigabit PCIe Dual Port Fibre Channel Adapter
- FC 5774: 4 Gigabit PCIe Dual Port Fibre Channel Adapter

The 4 Gigabit PCIe Dual Port Fibre Channel Adapter is a 64 bit, low-profile, short form factor x4, PCIe adapter with an LC-type external fiber connector that provides single initiator capability over an optical fiber link or loop. The adapter automatically negotiates the highest data rate between the adapter and an attaching device at 1 Gbps, 2 Gbps, or 4 Gbps of which the device or switch is capable. Distances between the adapter and an attaching device or switch can reach up to 500 meters running at 1 Gbps data rate, up to 300 meters running at 2 Gbps data rate, and up to 150 meters running at 4 Gbps data rate. When used with IBM Fibre Channel storage switches supporting long-wave optics, the adapter can reach distances of up to 10 kilometers running at either 1 Gbps, 2 Gbps, or 4 Gbps data rates.

The adapter can be used to attach devices either directly, or with Fibre Channel switches. If you are attaching a device or switch with an SC type fiber connector, you must use an LC-SC 50 micron fiber converter cable (FC 2456) or an LC-SC 62.5 micron fiber converter cable (FC 2459).

The adapter has the following features:

- Compliant with the PCIe Base and Card Electromechanical (CEM) 1.0a specifications:
 - x1 and x4 lane link interface at 2.5 Gbit/s (auto-negotiated with system)
 - Supports VC0 (1 Virtual Channel) and TC0 (1 Traffic Class)
 - Configuration and IO Memory read/write, completion, message
 - Support for 64-bit addressing
 - ECC error protection
 - Link CRC on all PCIe packets and message information
 - Large payload size: 2048 bytes for read and write
 - Large read request size: 4096 bytes
- Compatible with 1, 2, and 4 Gb Fibre Channel interface:
 - Auto-negotiate between 1 Gb, 2 Gb or 4 Gb link attachments
 - Support for all Fibre Channel topologies: point-to-point, arbitrated loop, and fabric

- Support for Fibre Channel class 2 and 3
- Maximum Fibre Channel throughput achieved by using full duplex hardware support
- End-to-end data path parity and CRC protection, including internal data path RAMs
- Architectural support for multiple upper layer protocols
- Internal high-speed SRAM memory
- ECC protection of local memory, includes single-bit correction and double-bit protection
- Embedded shortwave optical connection with diagnostics capability
- Onboard Context Management by firmware (per port):
 - Up to 510 FC Port Logins
 - Up to 2047 concurrent Exchanges
 - I/O multiplexing down to the FC Frame level
- Data buffers capable of supporting 64+ buffer-to-buffer (BB) credits per port for shortwave applications
- Link management and recovery handled by firmware
- Onboard diagnostic capability accessible by optional connection
- Parts and construction compliant with the European Union Directive of Restriction of Hazardous Substances (RoHS)
- Performance up to 4.25 Gbps full duplex

The following figure shows the adapter.

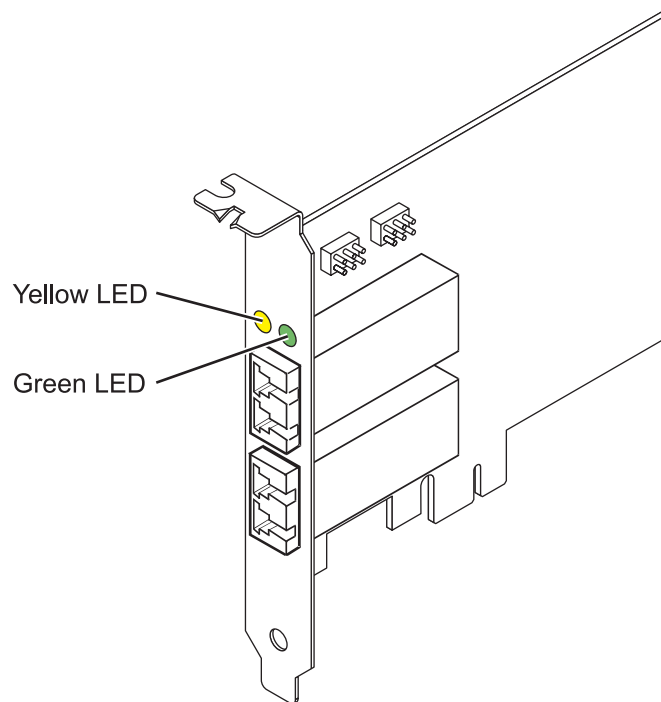

Figure 7. 5276 adapter

Specifications

Item	Description
Adapter FRU number	10N7255*

* Designed to comply with RoHS requirement

Wrap plug FRU number	11P3847
----------------------	---------

I/O bus architecture

PCIe Base and CEM 1.0a
x4 PCIe bus interface

Slot requirement

One available PCIe x4, x8, or x16 slot

Voltage

3.3V

Form factor

Short, low-profile

FC compatibility

1, 2, 4 gigabit

Cables

50/125 micron fiber (500 MHz*km bandwidth cable)

- 1.0625 Gbps 0.5 – 500 m
- 2.125 Gbps 0.5 – 300 m
- 4.25 Gbps 0.5 – 150 m

62.5/125 micron fiber (200 MHz*km bandwidth cable)

- 1.0625 Gbps 0.5 – 300 m
- 2.125 Gbps 0.5 – 150 m
- 4.25 Gbps 0.5 – 70 m

Maximum number

For the maximum adapters supported, see the PCI adapter placement topic collection for your system.

For details about slot priorities and placement rules, see the PCI adapter placement topic collection for your system.

Operating system or partition requirements

If you are installing a new feature, ensure that you have the software that is required to support the new feature and that you determine whether there are any prerequisites for this feature and attaching devices. To check for the prerequisites, see IBM Prerequisite website (www-912.ibm.com/e_dir/eServerPrereq.nsf).

The adapter is supported on the following versions of the operating systems:

- AIX
 - AIX Version 7.1, or later.
 - AIX Version 6.1, or later.
 - AIX Version 5.3, or later.
- Linux
 - Red Hat Enterprise Linux 5.6 for POWER, or later.
 - Novel SUSE Linux Enterprise Server 11 Service Pack 1, or later.
- IBM i
 - IBM i 7.1, or later
 - IBM i 6.1, or later

Adapter LED states

Green and yellow LEDs can be seen through openings in the mounting bracket of the adapter. Green indicates firmware operation and yellow signifies port activity. Table 7 on page 21 summarizes normal LED states. There is a 1 Hz pause when the LED is off between each group of fast flashes (1, 2 or 3). Observe the LED sequence for several seconds to ensure that you correctly identify the state.

Table 7. Normal LED states

Green LED	Yellow LED	State
On	1 fast flash	1 Gbps link rate - normal, link active
On	2 fast flashes	2 Gbps link rate - normal, link active
On	3 fast flashes	4 Gbps link rate - normal, link active

Power-On Self Test (POST) conditions and results are summarized in Table 8. These states can be used to identify abnormal states or problems.

Table 8. POST conditions and results

Green LED	Yellow LED	State
Off	Off	Wake-up failure (dead board)
Off	On	POST failure (dead board)
Off	Slow flash	Wake-up failure monitor
Off	Fast flash	Failure in post
Off	Flashing	Post processing in progress
On	Off	Failure while functioning
On	On	Failure while functioning
Slow flash	Off	Normal, link down
Slow flash	On	Not defined
Slow flash	Slow flash	Offline for download
Slow flash	Fast flash	Restricted offline mode, waiting for restart
Slow flash	Flashing	Restricted offline mode, test active
Fast flash	Off	Debug monitor in restricted mode
Fast flash	On	Not defined
Fast flash	Slow flash	Debug monitor in test fixture mode
Fast flash	Fast flash	Debug monitor in remote debug mode
Fast flash	Flashing	Not defined

Device ID jumper

The default setting for the two device ID jumpers labeled P0_JX. and P1_JX is to set the jumpers on pins 1 and 2 as shown in Figure 8 on page 22. Do not change the jumper settings for a standard installation.

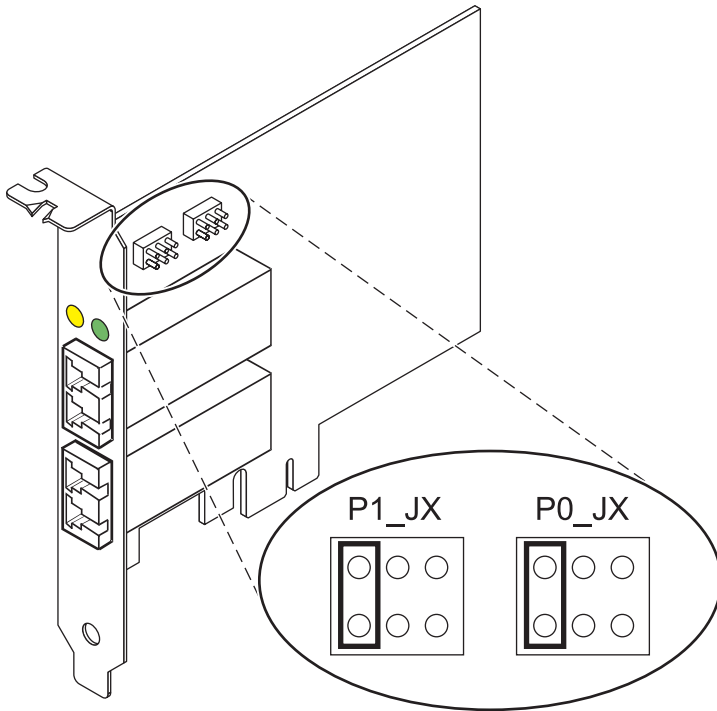

Figure 8. Device ID jumper

Replacing hot swap HBAs

Fiber Channel host bus adapters (HBAs) connected to a fiber array storage technology (FAStT) or DS4000® storage subsystem have a child device called a disk array router (dar). You must unconfigure the disk array router before you can hot swap an HBA that is connected to a FAStT or DS4000 storage subsystem. For instructions, see *Replacing hot swap HBAs in the IBM System Storage® DS4000 Storage Manager Version 9, Installation and Support Guide for AIX, HP-UX, Solaris, and Linux on Power Systems™ Servers*, order number GC26-7848.

Related tasks:

[Installing PCI adapters](#)

Related reference:

[IBM Prerequisite website](#)

[Parts information](#)

[PCI adapter placement](#)

“Backplane daughter cards and RAID enablement cards” on page 2

Find links to topics that cover Backplane daughter cards and RAID enablement cards.

PCIe3 LP 16 Gb 2-port Fibre Channel Adapter (FC EN0B; CCIN 577F)

Learn about the specifications and operating system requirements for the feature code (FC) EN0B adapter.

Overview

The PCIe3 LP 16 Gb 2-port Fibre Channel Adapter is a PCI Express (PCIe) generation 3 (Gen3) x8, short form-factor, low-profile adapter. This adapter has a little connector-type (LC) external fiber connector that provides single initiator capability over an optical fiber link. The adapter automatically negotiates the highest data rate between the adapter and an attaching device at a link speed of 16 Gbps, 8 Gbps, or 4 Gbps. The adapter supports a maximum link speed of 16 Gbps at both ports. Distances between the adapter and an attaching device or switch can reach up to 380 m running at a 4 Gbps data rate, up to 150

m running at an 8 Gbps data rate, and up to 100 m running at a 16 Gbps data rate. When used with IBM Fibre Channel storage switches supporting long-wave optics, the adapter can reach distances of up to 10 km running at 4 Gbps, 8 Gbps, or 16 Gbps data rates.

The adapter has the following features:

- This adapter has parts and construction compliant with the European Union Directive of Restriction of Hazardous Substances (RoHS)
- The adapter is compliant with the PCIe base and Card Electromechanical (CEM) 3.0 specifications with the following characteristics:
 - Provides an x8 lane link interface at 14.025 Gbps, 8.5 Gbps, or 4.25 Gbps (automatic negotiation with system)
 - Provides support for one Virtual Channel (VC0) and one Traffic Class (TC0)
 - Provides configuration and I/O memory read and write, completion, and messaging capabilities
 - Provides support for 64-bit addressing
 - Provides error correction code (ECC) and error protection functions
 - Provides link cyclic redundancy check (CRC) on all PCIe packets and message information
 - Provides a large payload size of 2048 bytes for read and write functions
 - Provides a large read request size of 4096 bytes
- The adapter is compatible with 4, 8, and 16 Gb Fibre Channel interface with the following characteristics:
 - Provides for automatic negotiation between 4 Gb, 8 Gb, or 16 Gb link attachments
 - Provides support for the following Fibre Channel topologies: point-to-point (16Gb only) and fabric
 - Provides support for Fibre Channel class 3
 - Provides a maximum Fibre Channel throughput that is achieved by using full duplex hardware support
- The adapter provides an end-to-end data path parity and CRC protection, including internal data path random-access memory (RAM)
- Provides architectural support for multiple upper layer protocols
- Provides comprehensive virtualization capabilities with support for N_Port ID Virtualization (NPIV) and virtual fabric (VF)
- Provides support for message signaled interrupts extended (MSI-X)
- Provides support for 255 VFs and 1024 MSi-X
- Provides an internal, high-speed static random-access memory (SRAM) memory
- Provides ECC protection of local memory that includes single-bit correction and double-bit protection
- Provides an embedded shortwave optical connection with diagnostics capability
- Provides support for an on-board context management by firmware:
 - Up to 8192 FC port logins
 - I/O multiplexing down to the Fibre Channel frame level
- Provides data buffers capable of supporting 64+ buffer-to-buffer (BB) credits per port for shortwave applications
- Provides link management and recovery that is handled by firmware
- Provides on-board diagnostic capability accessible by an optional connection
- Provides a performance up to 16 Gbps full duplex

The following figure shows the adapter.

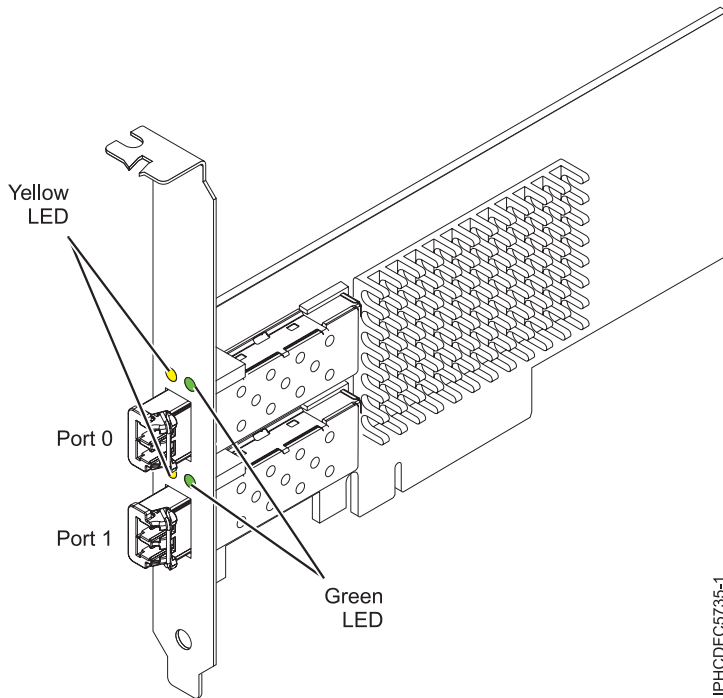

Figure 9. ENOB adapter

Specifications

Item	Description
Adapter FRU number	74Y2221 (Designed to comply with RoHS requirement)
Wrap plug FRU number	12R9314
I/O bus architecture	PCIe base and CEM 3.0, x8 PCIe bus interface
Slot requirement	One available PCIe x8 or x16 slot
Voltage	3.3 V, 12 V
Form factor	Short, low-profile
FC compatibility	4, 8, 16 Gb

Cables

Cables are the responsibility of the customer. Use multimode fiber optic cables with shortwave lasers that adhere to the following specifications:

- OM3: Multimode 50/125 micron fiber, 2000 MHz x km bandwidth
- OM2: Multimode 50/125 micron fiber, 500 MHz x km bandwidth
- OM1: Multimode 62.5/125 micron fiber, 200 MHz x km bandwidth

Because core sizes are different, OM1 cables can only be connected to other OM1 cables. For best results, OM2 cables must not be connected to OM3 cables. However, if an OM2 cable is connected to an OM3 cable, the characteristics of the OM2 cable apply to the entire length of the cables.

The following table shows the supported distances for the different cable types at the different link speeds.

Table 9. Supported distances for cables

Header	Cable type and distance		
	OM1	OM2	OM3
Rate			
4.25 Gbps	0.5 - 70 m (1.64 - 229.65 ft)	0.5 - 150 m (1.64 - 492.12 ft)	0.5 - 380 m (1.64 - 1246.71 ft)
8.5 Gbps	0.5 - 21 m (1.64 - 68.89 ft)	0.5 - 50 m (1.64 - 164.04 ft)	0.5 - 150 m (1.64 - 492.12 ft)
14.025 Gbps	0.5 - 15 m (1.64 - 49.21 ft)	0.5 - 35 m (1.64 - 114.82 ft)	0.5 - 100 m (1.64 - 328.08 ft)

Maximum number

For the maximum adapters supported, see the PCI adapter placement topic collection for your system.

Operating system or partition requirements

If you are installing a new feature, ensure that you have the software that is required to support the new feature and that you determine whether there are any prerequisites for this feature and attaching devices. To check for the prerequisites, see IBM Prerequisite website (www-912.ibm.com/e_dir/eServerPrereq.nsf).

The adapter is supported on the following versions of the operating systems:

- AIX
 - AIX 7.1, or later
 - AIX 6.1, or later
- Linux
 - Red Hat Enterprise Linux
 - SUSE Linux Enterprise Server
 - For support details, see the Linux Alert website (www14.software.ibm.com/webapp/set2/sas/f/lopdiags/info/LinuxAlerts.htm)
- IBM i
 - IBM i 7.1, or later
 - IBM i 6.1, or later

Adapter LED states

Green and yellow LEDs can be seen through openings in the mounting bracket of the adapter. Green indicates firmware operation, and yellow signifies port activity. Table 10 summarizes normal LED states. A 1 Hz pause occurs when the LED is off between each group of fast flashes (2, 3 or 4). Observe the LED sequence for several seconds to ensure that you correctly identify the state.

Table 10. Normal LED states

Green LED	Yellow LED	State
On	2 fast flashes	4 Gbps link rate: normal, link active
On	3 fast flashes	8 Gbps link rate: normal, link active
On	4 fast flashes	16 Gbps link rate: normal, link active

Power-on-self-test (POST) conditions and results are summarized in Table 11 on page 26. These states can be used to identify abnormal states or problems.

Table 11. POST conditions and results

Green LED	Yellow LED	State
Off	Off	Wake-up failure of the adapter board
Off	On	POST failure of the adapter board
Off	Slow flash	Wake-up failure monitor
Off	Fast flash	Failure in post
Off	Flashing	Postprocessing in progress
On	Off	Failure while functioning
On	On	Failure while functioning
Slow flash	Off	Normal, link down
Slow flash	On	Not defined
Slow flash	Slow flash	Offline for download
Slow flash	Fast flash	Restricted offline mode, waiting for restart
Slow flash	Flashing	Restricted offline mode, test active
Fast flash	Off	Debug monitor in restricted mode
Fast flash	On	Not defined
Fast flash	Slow flash	Debug monitor in test fixture mode
Fast flash	Fast flash	Debug monitor in remote debug mode
Fast flash	Flashing	Not defined

Related tasks:

[Installing PCI adapters](#)

Related reference:

[IBM Prerequisite website](#)

[Parts information](#)

[PCI adapter placement](#)

“Backplane daughter cards and RAID enablement cards” on page 2

Find links to topics that cover Backplane daughter cards and RAID enablement cards.

8 Gigabit PCI Express Dual Port Fibre Channel Adapter (FC 5735; CCIN 577D)

Learn about the specifications and operating system requirements for the feature code (FC) 5735 adapter.

Overview

The 8 Gigabit PCI Express Dual Port Fibre Channel Adapter is a high-performance adapter based on the Emulex LPe12002 PCIe Host Bus Adapter (HBA). Each port provides single initiator capability over a fibre link. The ports have LC type connectors and utilize shortwave laser optics. The adapter connects to fibre channel switches and operates at link speeds of 2, 4, and 8 Gbps. The adapter automatically negotiates with the switch to the highest speed of which the switch is capable. LEDs on each port provide information on the status and link speed of the port.

The following figure shows the adapter:

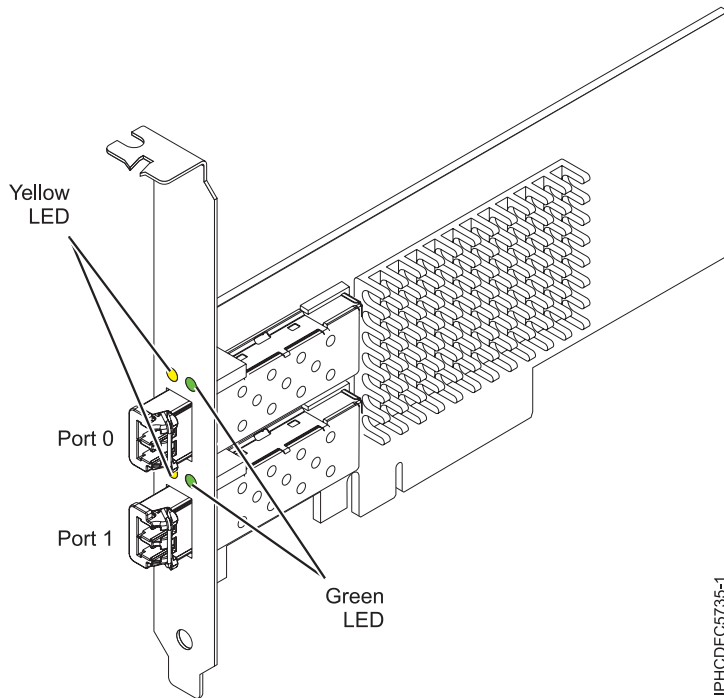

Figure 10. 5735 adapter

For details about slot priorities and placement rules, see the PCI adapter placement topic collection for your system.

Adapter specifications

Item Description

FRU number

10N9824 (Designed to comply with RoHS requirement)

Wrap plug FRU number

12R9314 (Designed to comply with RoHS requirement)

11P3847 (Not designed to comply with RoHS requirement)

I/O bus architecture

PCI Express (PCIe) Base and Card Electromechanical (CEM) 2.0
x8 PCIe bus interface

Slot requirement

One available PCIe x8 or x16 slot

Voltage

3.3 V

Form factor

Short, low-profile with standard size bracket

FC compatibility

2, 4, 8 Gigabit

Cables

Cables are the responsibility of the customer. Use multimode fibre optic cables with short-wave lasers that adhere to the following specifications:

- OM3: Multimode 50/125 micron fibre, 2000 MHz x km bandwidth
- OM2: Multimode 50/125 micron fibre, 500 MHz x km bandwidth
- OM1: Multimode 62.5/125 micron fibre, 200 MHz x km bandwidth

Because core sizes are different, OM1 cables can only be connected to other OM1 cables. For best results, OM2 cables should not be connected to OM3 cables. However, if an OM2 cable is connected to an OM3 cable, the characteristics of the OM2 cable apply to the entire length of the cables.

The following table shows the supported distances for the three different cable types at the three different link speeds.

Table 12. Supported cable distances by link speed

Cable type	2.125 Gbps	4.25 Gbps	8.5 Gbps
OM3	0.5 m - 500 m	0.5 m - 380 m	0.5 m - 150 m
OM2	0.5 m - 300 m	0.5 m - 150 m	0.5 m - 50 m
OM1	0.5 m - 150 m	0.5 m - 70 m	0.5 m - 21 m

Maximum number

For the maximum adapters supported, see the PCI adapter placement topic collection for your system.

Operating system or partition requirements

If you are installing a new feature, ensure that you have the software that is required to support the new feature and that you determine whether there are any prerequisites for this feature and attaching devices. To check for the prerequisites, see IBM Prerequisite website (www-912.ibm.com/e_dir/eServerPrereq.nsf).

The adapter is supported on the following versions of the operating systems:

- AIX
 - AIX Version 7.1, or later
 - AIX Version 6.1, or later
 - AIX Version 5.3, or later
- Linux
 - Red Hat Enterprise Linux 6.1 for POWER, or later
 - SUSE Linux Enterprise Server 11, Service Pack 1, or later (with update package)
 - For support details, see the Linux Alert website (www14.software.ibm.com/webapp/set2/sas/f/lopdiags/info/LinuxAlerts.htm)
- IBM i
 - IBM i 7.1, or later.
 - IBM i 6.1, or later.

Adapter LED

Green and yellow LEDs can be seen through openings in the adapter mounting bracket. Green indicates firmware operation and yellow signifies port activity. Table 13 summarizes the link rate conditions. There is a 1-second pause when the LED is off between each group of fast flashes (2, 3, or 4). Observe the LED sequence for several seconds to be sure that you have correctly identified the state.

Table 13. Normal LED states

Green LED	Yellow LED	State
Slow flash	Off	Normal, link inactive or not started
On	2 fast flashes	2 Gbps link rate - normal, link active
On	3 fast flashes	4 Gbps link rate - normal, link active
On	4 fast flashes	8 Gbps link rate - normal, link active

Power-on self test (POST) conditions and results are summarized in Table 14. These states can be used to identify abnormal states or problems. Follow the action to be taken for each condition.

Table 14. POST conditions and results

Green LED	Yellow LED	State	Action to be taken
Off	Off	Wake-up failure (dead board)	Perform AIX, Linux or IBM i operating system diagnostics.
Off	On	POST failure (dead board)	Perform AIX, Linux or IBM i operating system diagnostics.
Off	Slow blink	Wake-up failure monitor	Perform AIX, Linux or IBM i operating system diagnostics.
Off	Fast blink	POST failure	Perform AIX, Linux or IBM i operating system diagnostics.
Off	Flashing	POST processing in progress	None
On	Off	Failure while functioning	Perform AIX, Linux or IBM i operating system diagnostics.
On	On	Failure while functioning	Perform AIX, Linux or IBM i operating system diagnostics.
Slow blink	Slow blink	Offline for download	None
Slow blink	Fast blink	Restricted offline mode, waiting for restart	None
Slow blink	Flashing	Restricted offline mode, test active	None

Replacing Fibre Channel adapters using hot swap

When hot swapping fibre channel adapters, be aware that device-related software for the storage devices might have additional devices (for example, the dar device associated with the FASTT or DS4800) that need to be removed. Refer to specific storage device documentation for information about how to remove these additional devices.

The new adapter has a unique worldwide port name (WWPN). Check the zoning and LUN assignments to ensure that the new adapter will function as expected.

Related tasks:

[Installing PCI adapters](#)

Related reference:

[IBM Prerequisite website](#)

[Parts information](#)

[PCI adapter placement](#)

“Backplane daughter cards and RAID enablement cards” on page 2

Find links to topics that cover Backplane daughter cards and RAID enablement cards.

4 Gigabit PCI Express Single Port Fibre Channel Adapter (FC 5773; CCIN 5773)

Learn about the specifications and operating system requirements for the feature code (FC) 5773 adapter.

Overview

The 4 Gigabit PCI Express Single Port Fibre Channel adapter is a 64 bit, short form factor x4, PCIe adapter with an LC-type external fiber connector that provides single initiator capability over an optical fiber link or loop. The adapter automatically negotiates the highest data rate between the adapter and an attaching device at 1 Gbps, 2 Gbps, or 4 Gbps of which the device or switch is capable of. Distances between the adapter and an attaching device or switch can reach up to 500 meters running at 1 Gbps data rate, up to 300 meters running at 2 Gbps data rate, and up to 150 meters running at 4 Gbps data rate. When used with IBM Fibre Channel storage switches that support longwave optics, the adapter can reach distances of up to 10 kilometers running at either 1 Gbps, 2 Gbps, or 4 Gbps data rates.

The adapter can be used to attach devices either directly, or with Fibre Channel switches. If you are attaching a device or switch with an SC type fiber connector, you must use an LC-SC 50 micron fiber converter cable (FC 2456) or an LC-SC 62.5 micron fiber converter cable (FC 2459).

The adapter has the following features:

- Compliant with the PCIe Base and Card Electromechanical (CEM) 1.0a specifications:
 - x1 and x4 lane link interface at 2.5 Gbit/s (auto-negotiated with system)
 - Supports VC0 (1 Virtual Channel) and TC0 (1 Traffic Class)
 - Configuration and IO Memory read/write, completion, message
 - Support for 64-bit addressing
 - ECC error protection
 - Link CRC on all PCIe packets and message information
 - Large payload size: 2048 bytes for read and write
 - Large read request size: 4096 bytes
- Compatible with 1, 2, and 4 Gb Fibre Channel interface:
 - Auto-negotiate between 1 Gb, 2 Gb or 4 Gb link attachments
 - Support for all Fibre Channel topologies: point-to-point, arbitrated loop, and fabric
 - Support for Fibre Channel class 2 and 3
 - Maximum Fibre Channel throughput achieved by using full duplex hardware support
- End-to-end data path parity and CRC protection, including internal data path RAMs
- Architectural support for multiple upper layer protocols
- Internal high-speed SRAM memory
- ECC protection of local memory, includes single-bit correction and double-bit protection
- Embedded shortwave optical connection with diagnostics capability
- Onboard Context Management by firmware (per port):
 - Up to 510 FC Port Logins
 - Up to 2047 concurrent Exchanges
 - I/O multiplexing down to the FC Frame level
- Data buffers capable of supporting 64+ buffer-to-buffer (BB) credits per port for shortwave applications
- Link management and recovery handled by firmware
- Onboard diagnostic capability accessible by optional connection
- Parts and construction compliant with the European Union Directive of Restriction of Hazardous Substances (RoHS)
- Performance up to 4.25 Gbps full duplex

The following figure shows the adapter.

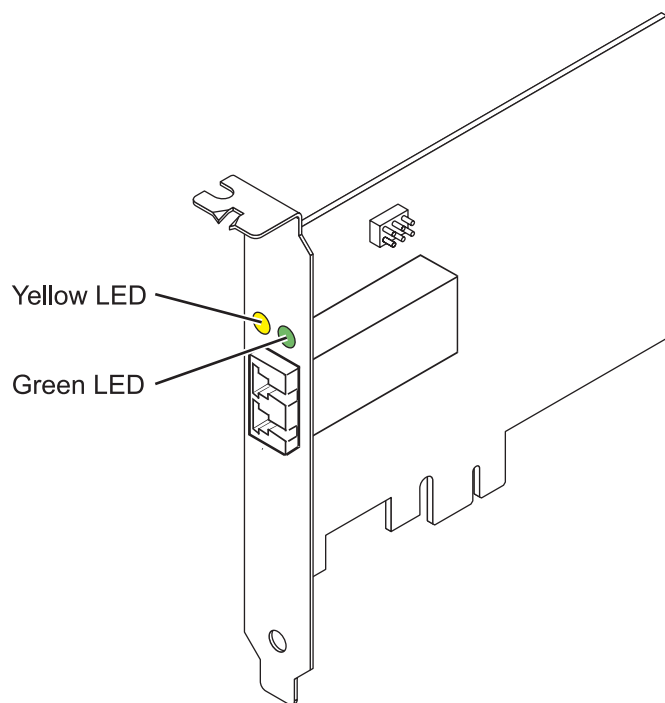

Figure 11. 5773 adapter

Adapter specifications

Item Description

FRU number
10N7249*

*Designed to comply with RoHS requirement.

Wrap plug FRU number
12R9314 (for Fibre LC connector)

Note: The wrap plug is included with the card, and can also be bought from IBM.

I/O bus architecture

PCI Express (PCIe) Base and CEM 1.0a
x4 PCIe bus interface

Slot requirement

One available PCIe x4, x8, or x16 slot

Voltage

3.3 V

Form factor

Short, low-profile

FC compatibility

1, 2, 4 gigabit

Cables

50/125 micron fiber (500 MHz*km bandwidth cable)

- 1.0625 Gbps 0.5 – 500 m
- 2.125 Gbps 0.5 – 300 m
- 4.25 Gbps 0.5 – 150 m

62.5/125 micron fiber (200 MHz*km bandwidth cable)

- 1.0625 Gbps 0.5 – 300 m
- 2.125 Gbps 0.5 – 150 m
- 4.25 Gbps 0.5 – 70 m

Maximum number

For the maximum adapters supported, see the PCI adapter placement topic collection for your system.

For details about slot priorities and placement rules, see the PCI adapter placement topic collection for your system.

Operating system or partition requirements

The adapter is supported under the following versions of the operating systems:

- AIX
 - AIX 5.3, or later
- Linux
 - Red Hat Enterprise Linux version 4
 - Red Hat Enterprise Linux version 5
 - SUSE Linux Enterprise Server 9, Service Pack 4, or later
 - SUSE Linux Enterprise Server 10, Service Pack 1, or later

Note: If you are installing a new feature, ensure that you have the software that is required to support the new feature and that you determine whether there are any prerequisites. To check for the prerequisites, see IBM Prerequisite website (www-912.ibm.com/e_dir/eServerPrereq.nsf).

Adapter LED states

Green and yellow LEDs can be seen through openings in the mounting bracket of the adapter. Green indicates firmware operation and yellow signifies port activity. Table 15 summarizes normal LED states. There is a 1 Hz pause when the LED is off between each group of fast flashes (1, 2 or 3). Observe the LED sequence for several seconds to ensure that you correctly identify the state.

Table 15. Normal LED states

Green LED	Yellow LED	State
On	1 fast flash	1 Gbps link rate - normal, link active
On	2 fast flashes	2 Gbps link rate - normal, link active
On	3 fast flashes	4 Gbps link rate - normal, link active

Power-On Self Test (POST) conditions and results are summarized in Table 16. These states can be used to identify abnormal states or problems.

Table 16. POST conditions and results

Green LED	Yellow LED	State
Off	Off	Wake-up failure (dead board)
Off	On	POST failure (dead board)
Off	Slow flash	Wake-up failure monitor
Off	Fast flash	Failure in post
Off	Flashing	Post processing in progress
On	Off	Failure while functioning
On	On	Failure while functioning
Slow flash	Off	Normal, link down
Slow flash	On	Not defined

Table 16. POST conditions and results (continued)

Green LED	Yellow LED	State
Slow flash	Slow flash	Offline for download
Slow flash	Fast flash	Restricted offline mode, waiting for restart
Slow flash	Flashing	Restricted offline mode, test active
Fast flash	Off	Debug monitor in restricted mode
Fast flash	On	Not defined
Fast flash	Slow flash	Debug monitor in test fixture mode
Fast flash	Fast flash	Debug monitor in remote debug mode
Fast flash	Flashing	Not defined

Device ID jumper

The default setting for the device ID jumper labeled P0_JX is to set the jumper on pins 1 and 2 as shown in Figure 12. Do not change the jumper settings for a standard installation.

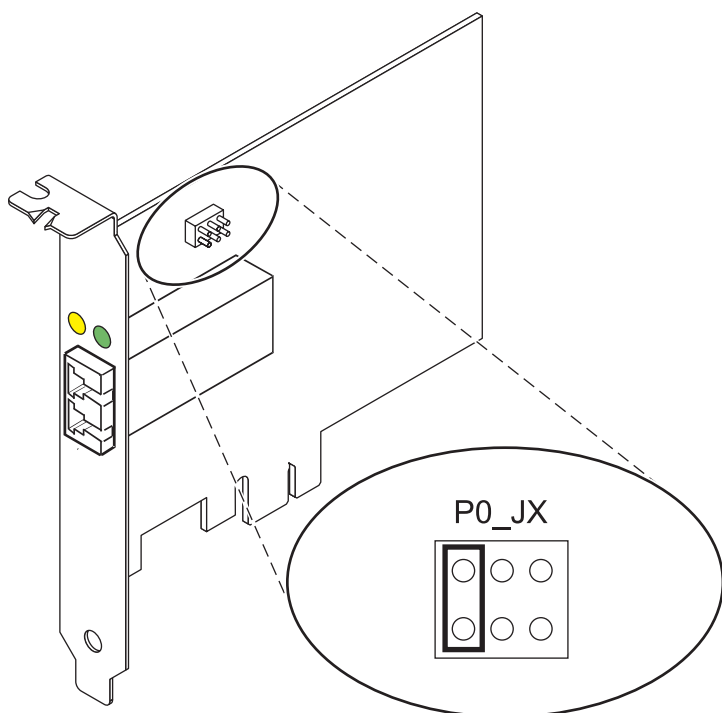

Figure 12. Device ID jumper

Replacing hot swap HBAs

Fiber Channel host bus adapters (HBAs) connected to a fiber array storage technology (FAST) or DS4000 storage subsystem have a child device called a disk array router (dar). You must unconfigure the disk array router before you can hot swap an HBA that is connected to a FAST or DS4000 storage subsystem. For instructions, see *Replacing hot swap HBAs* in the *IBM System Storage DS4000 Storage Manager Version 9, Installation and Support Guide for AIX, HP-UX, Solaris, and Linux on Power Systems Servers*, order number GC26-7848.

Related tasks:

[🔗 Installing PCI adapters](#)

Related reference:

[🔗 IBM Prerequisite website](#)

[🔗 Parts information](#)

[🔗 PCI adapter placement](#)

“Backplane daughter cards and RAID enablement cards” on page 2

Find links to topics that cover Backplane daughter cards and RAID enablement cards.

4 Gigabit PCI Express Dual Port Fibre Channel Adapter (FC 5774; CCIN 5774)

Learn about the specifications and operating system requirements for the feature code (FC) 5774 adapter.

Overview

The 4 Gigabit PCI Express Dual Port Fibre Channel Adapter is a 64 bit, short form factor x4, PCIe adapter with an LC-type external fiber connector that provides single initiator capability over an optical fiber link or loop. The adapter automatically negotiates the highest data rate between the adapter and an attaching device at 1 Gbps, 2 Gbps, or 4 Gbps of which the device or switch is capable. Distances between the adapter and an attaching device or switch can reach up to 500 meters running at 1 Gbps data rate, up to 300 meters running at 2 Gbps data rate, and up to 150 meters running at 4 Gbps data rate. When used with IBM Fibre Channel storage switches supporting long-wave optics, the adapter can reach distances of up to 10 kilometers running at either 1 Gbps, 2 Gbps, or 4 Gbps data rates.

The adapter can be used to attach devices either directly, or with Fibre Channel switches. If you are attaching a device or switch with an SC type fiber connector, you must use an LC-SC 50 micron fiber converter cable (FC 2456) or an LC-SC 62.5 micron fiber converter cable (FC 2459).

The adapter has the following features:

- Compliant with the PCIe Base and Card Electromechanical (CEM) 1.0a specifications:
 - x1 and x4 lane link interface at 2.5 Gbit/s (auto-negotiated with system)
 - Supports VC0 (1 Virtual Channel) and TC0 (1 Traffic Class)
 - Configuration and IO Memory read/write, completion, message
 - Support for 64-bit addressing
 - ECC error protection
 - Link CRC on all PCIe packets and message information
 - Large payload size: 2048 bytes for read and write
 - Large read request size: 4096 bytes
- Compatible with 1, 2, and 4 Gb Fibre Channel interface:
 - Auto-negotiate between 1 Gb, 2 Gb or 4 Gb link attachments
 - Support for all Fibre Channel topologies: point-to-point, arbitrated loop, and fabric
 - Support for Fibre Channel class 2 and 3
 - Maximum Fibre Channel throughput achieved by using full duplex hardware support
- End-to-end data path parity and CRC protection, including internal data path RAMs
- Architectural support for multiple upper layer protocols
- Internal high-speed SRAM memory
- ECC protection of local memory, includes single-bit correction and double-bit protection
- Embedded shortwave optical connection with diagnostics capability
- Onboard Context Management by firmware (per port):

- Up to 510 FC Port Logins
- Up to 2047 concurrent Exchanges
- I/O multiplexing down to the FC Frame level
- Data buffers capable of supporting 64+ buffer-to-buffer (BB) credits per port for shortwave applications
- Link management and recovery handled by firmware
- Onboard diagnostic capability accessible by optional connection
- Parts and construction compliant with the European Union Directive of Restriction of Hazardous Substances (RoHS)
- Performance up to 4.25 Gbps full duplex

The following figure shows the adapter.

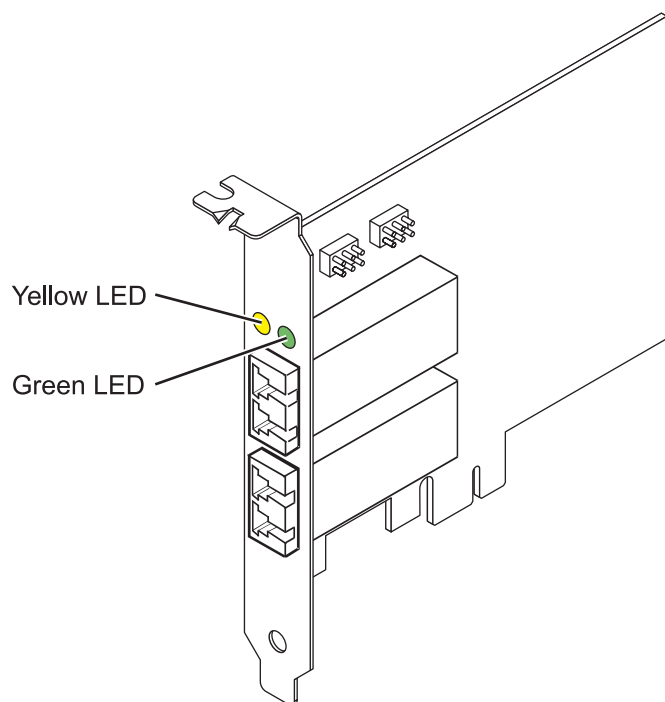

Figure 13. 5774 adapter

Specifications

Item Description

Adapter FRU number

10N7255*

* Designed to comply with RoHS requirement

Wrap plug FRU number

11P3847

I/O bus architecture

PCIe Base and CEM 1.0a

x4 PCIe bus interface

Slot requirement

One available PCIe x4, x8, or x16 slot

Voltage

3.3 V

Form factor

Short, low-profile

FC compatibility

1, 2, 4 gigabit

Cables

50/125 micron fiber (500 MHz*km bandwidth cable)

- 1.0625 Gbps 0.5 – 500 m
- 2.125 Gbps 0.5 – 300 m
- 4.25 Gbps 0.5 – 150 m

62.5/125 micron fiber (200 MHz*km bandwidth cable)

- 1.0625 Gbps 0.5 – 300 m
- 2.125 Gbps 0.5 – 150 m
- 4.25 Gbps 0.5 – 70 m

Maximum number

For the maximum adapters supported, see the PCI adapter placement topic collection for your system.

For details about slot priorities and placement rules, see the PCI adapter placement topic collection for your system.

Operating system or partition requirements

If you are installing a new feature, ensure that you have the software that is required to support the new feature and that you determine whether there are any prerequisites for this feature and attaching devices. To check for the prerequisites, see IBM Prerequisite website (www-912.ibm.com/e_dir/eServerPrereq.nsf).

The adapter is supported on the following versions of the operating systems:

- AIX
 - AIX 7.1, or later
 - AIX 6.1, or later
 - AIX 5.3, or later
- Linux
 - Red Hat Enterprise Linux 5.6 for POWER, or later
 - SUSE Linux Enterprise Server 11 Service Pack 1, or later
- IBM i
 - IBM i 7.1, or later
 - IBM i 6.1, or later

Adapter LED states

Green and yellow LEDs can be seen through openings in the mounting bracket of the adapter. Green indicates firmware operation and yellow signifies port activity. Table 17 summarizes normal LED states. There is a 1 Hz pause when the LED is off between each group of fast flashes (1, 2 or 3). Observe the LED sequence for several seconds to ensure that you correctly identify the state.

Table 17. Normal LED states

Green LED	Yellow LED	State
On	1 fast flash	1 Gbps link rate - normal, link active
On	2 fast flashes	2 Gbps link rate - normal, link active
On	3 fast flashes	4 Gbps link rate - normal, link active

Power-On Self Test (POST) conditions and results are summarized in Table 18 on page 37. These states can be used to identify abnormal states or problems.

Table 18. POST conditions and results

Green LED	Yellow LED	State
Off	Off	Wake-up failure (dead board)
Off	On	POST failure (dead board)
Off	Slow flash	Wake-up failure monitor
Off	Fast flash	Failure in post
Off	Flashing	Post processing in progress
On	Off	Failure while functioning
On	On	Failure while functioning
Slow flash	Off	Normal, link down
Slow flash	On	Not defined
Slow flash	Slow flash	Offline for download
Slow flash	Fast flash	Restricted offline mode, waiting for restart
Slow flash	Flashing	Restricted offline mode, test active
Fast flash	Off	Debug monitor in restricted mode
Fast flash	On	Not defined
Fast flash	Slow flash	Debug monitor in test fixture mode
Fast flash	Fast flash	Debug monitor in remote debug mode
Fast flash	Flashing	Not defined

Device ID jumper

The default setting for the two device ID jumpers labeled P0_JX. and P1_JX is to set the jumpers on pins 1 and 2 as shown in Figure 14 on page 38. Do not change the jumper settings for a standard installation.

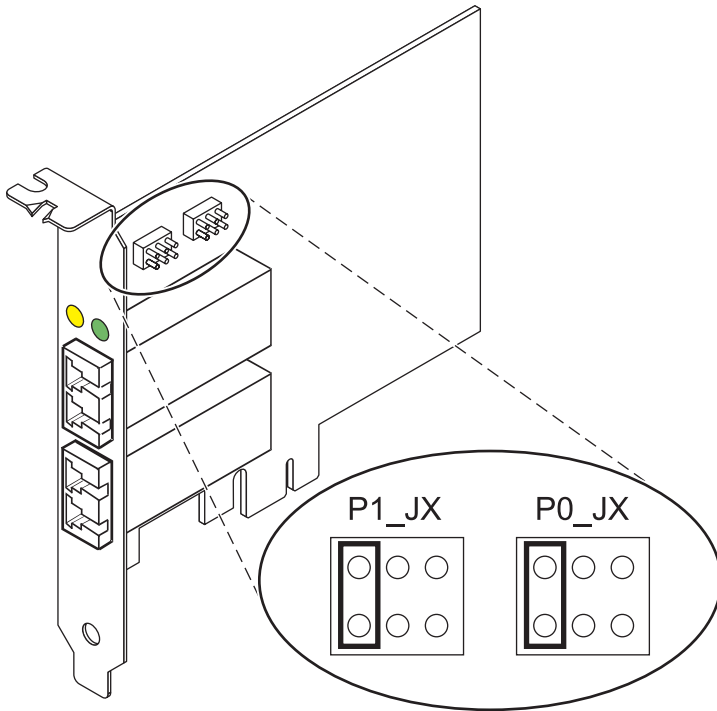

Figure 14. Device ID jumper

Replacing hot swap HBAs

Fiber Channel host bus adapters (HBAs) connected to a fiber array storage technology (FAS[®]T) or DS4000 storage subsystem have a child device called a disk array router (dar). You must unconfigure the disk array router before you can hot swap an HBA that is connected to a FAS[®]T or DS4000 storage subsystem. For instructions, see *Replacing hot swap HBAs* in the *IBM System Storage DS4000 Storage Manager Version 9, Installation and Support Guide for AIX, HP-UX, Solaris, and Linux on Power Systems Servers*, order number GC26-7848.

Related tasks:

[Installing PCI adapters](#)

Related reference:

[IBM Prerequisite website](#)

[Parts information](#)

[PCI adapter placement](#)

“Backplane daughter cards and RAID enablement cards” on page 2

Find links to topics that cover Backplane daughter cards and RAID enablement cards.

PCIe2 LP 8 Gb 4-port Fibre Channel Adapter (FC EN0Y; CCIN EN0Y)

Learn about the specifications and operating system requirements for the feature code (FC) EN0Y adapters.

Overview

The PCIe2 LP 8 Gb 4-port Fibre Channel Adapter is a PCI Express (PCIe) generation-2, low-profile, high-performance, x8 short form factor plus (SFF+) Host Bus Adapter (HBA). This adapter enables multiple logical (virtual) connections to share the same physical port. Each logical connection has its own resources and the ability to be managed independently. Each port provides single initiator capability over a fiber link or provides multiple initiator capability with N_Port ID Virtualization (NPIV). The ports are

connected by using mini little connectors (mini-LC) type connectors. These connectors use shortwave laser optics. The adapter operates at link speeds of 2, 4, and 8 gigabits per second (Gbps) and automatically negotiates to the highest speed possible. LEDs on each port provide information about the connection status and link speed of the port. The adapter connects to a Fibre Channel switch.

The LEDs on the adapter indicate the TX/RX and link status as shown in Table 19.

Figure 15 shows the adapter.

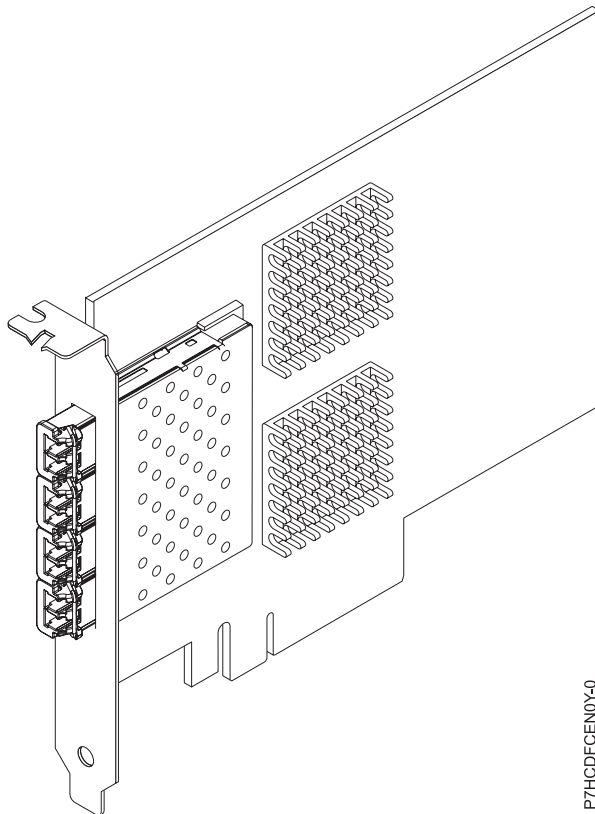

Figure 15. PCIe2 LP 8 Gb 4-port Fibre Channel Adapter

Table 19. LED indications

Hardware State	Yellow LED (8 Gbps)	Green LED (4 Gbps)	Amber LED (2 Gbps)	Comments
Power Off	Off	Off	Off	
Power On (before firmware initialization)	On	On	On	
Power On (after firmware initialization)	Flash	Flash	Flash	All flash at the same time.
Firmware Fault	Flash in sequence	Flash in sequence	Flash in sequence	Flashing in sequence of yellow LED, green LED, amber LED, then back to yellow LED.

Table 19. LED indications (continued)

Hardware State	Yellow LED (8 Gbps)	Green LED (4 Gbps)	Amber LED (2 Gbps)	Comments
2 Gbps Link UP/ACT	Off	Off	On/Flash	On for link up and flash if I/O activity.
4 Gbps Link UP/ACT	Off	On/Flash	Off	
8 Gbps Link UP/ACT	On/Flash	Off	Off	
Beacon	Flash	Off	Flash	All flashing at the same time.

Specifications

Item Description

Adapter FRU number

00E1578 (Designed to comply with RoHS requirement)

I/O bus architecture

PCIe2.0 x8

Slot requirement

One PCIe generation-2 x8 slot.

Cables

For information about the cables, see “Cables”

Voltage

3.3 V and 12.0 V

Form factor

Short, low-profile

Maximum number

For the maximum adapters supported, see the PCI adapter placement topic collection for your system.

Attributes provided

- NPIV capability is supported through VIOS.
- Requires a PCI Express generation-2 x8 slot for all four ports to operate at full speed.

For details about slot priorities and placement rules, see the PCI adapter placement topic collection for your system.

Cables

Use multimode fiber optic cables with shortwave lasers that adhere to the following specifications:

- OM3 - multimode 50/125 micron fiber, 2000 MHz x km bandwidth
- OM2 - multimode 50/125 micron fiber, 500 MHz x km bandwidth
- OM1 - multimode 62.5/125 micron fiber, 200 MHz x km bandwidth

The following table shows the supported distances for the three different cable types at the three different link speeds.

Table 20. Supported distances for cables

Rate	Cable Type and Distance		
	OM1	OM2	OM3
2.125 Gbps	0.5 meters to 150 meters (1.64 feet to 492.12 feet)	0.5 meters to 300 meters (1.64 feet to 984.25 feet)	0.5 meters to 500 meters (1.64 feet to 1640.41 feet)
4.25 Gbps	0.5 meters to 70 meters (1.64 feet to 229.65 feet)	0.5 meters to 150 meters (1.64 feet to 492.12 feet)	0.5 meters to 380 meters (1.64 feet to 1246.71 feet)
8.5 Gbps	0.5 meters to 21 meters (1.64 feet to 68.89 feet)	0.5 meters to 50 meters (1.64 feet to 164.04 feet)	0.5 meters to 150 meters (1.64 feet to 492.12 feet)

Because of their different core sizes, connect OM1 cables only to other OM1 cables. For best results, ensure that OM2 cables are not connected to OM3 cables. However, if an OM2 cable is connected to an OM3 cable, the characteristics of the OM2 cable gets applied to the entire length of the cables.

Operating system or partition requirements

This adapter is supported for the following versions of operating systems:

- AIX
 - AIX 7.1, Service Pack 4, or later.
 - AIX 6.1, Service Pack 8, or later.
 - AIX 6.1, Service Pack 6, or later.
 - AIX 5.3, Service Pack 6, or later.
- Linux
 - Red Hat Enterprise Linux Version 6.2, or later.
 - Red Hat Enterprise Linux Version 5.8, or later.
 - Novel SUSE Linux Enterprise Server 11, Service Pack 2, or later.
 - Novel SUSE Linux Enterprise Server 10, Service Pack 4, or later.
 - See the Linux Alert site for the support details.
- IBM i
 - IBM i 6.1.1 with 6.1.1 machine code 6.1.1, or later, supported through VIOS 2.2.1.4, or later.
- VIOS
 - VIOS support requires VIOS 2.2.1.4, or later.

Related tasks:

[Installing PCI adapters](#)

Related reference:

[IBM Prerequisite website](#)

[Parts information](#)

[PCI adapter placement](#)

“Backplane daughter cards and RAID enablement cards” on page 2

Find links to topics that cover Backplane daughter cards and RAID enablement cards.

PCIe LP POWER GXT145 Graphics Accelerator (FC 5269; CCIN 5269)

Learn about the features, requirements, installation notes, and troubleshooting tips for the PCIe LP POWER GXT145 Graphics Accelerator adapter.

Overview

The PCIe LP POWER GXT145 Graphics Accelerator adapter is a versatile 2D graphics accelerator and enhances the system unit video. This adapter supports both analog and digital monitors. The adapter requires a PCI Express slot. A short converter cable is included which adapts the 28-pin port on the adapter to dual DVI-I (analog/digital video) connectors. The adapter has no hardware switches to set. Mode selection is made through the software. Figure 16 on page 42 shows the adapter connector and converter cable.

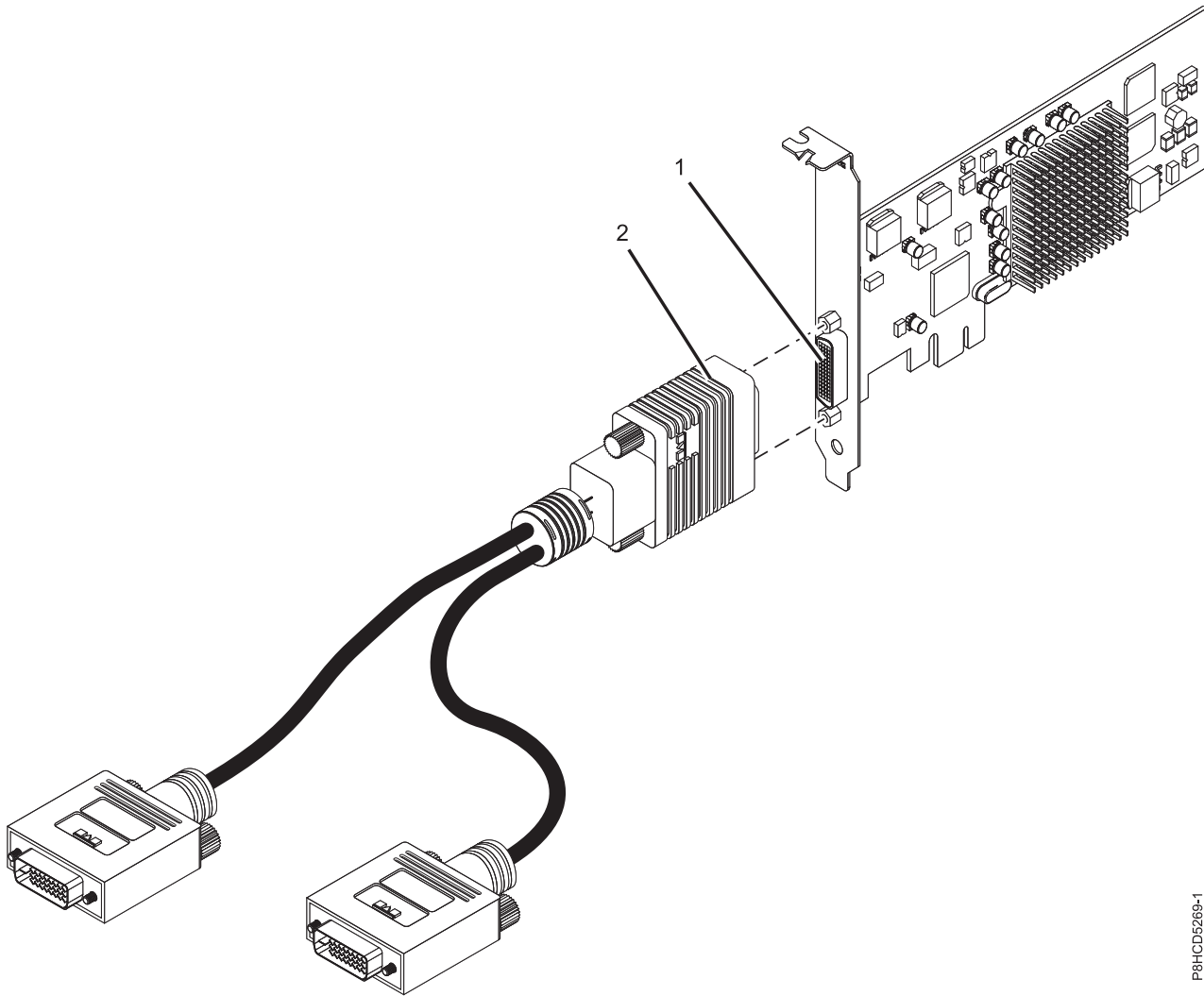

P8HCD5269-1

Figure 16. PCIe LP POWER GXT145 Graphics Accelerator adapter and converter cable

- 1 DVI connector (28 pin), analog, or digital
- 2 Converter cable with dual DVI-I (analog/digital video) connectors

If your monitor has a DVI connector, connect it directly to the main DVI connector (labeled 1/3) of your converter cable.

If attaching a device that requires a 15 pin D-Shell receptacle for a VGA connection (eg. when the graphic adapter output is routed directly to a 7316-TF3 display or indirectly through a KVM switch), order a VGA to DVI Connection Converter, feature number 4276 and connect it to the main DVI connector (labeled 1/3) of your converter cable.

If you're connecting only one monitor, use the main connector (labeled 1/3) of your converter cable.

In the system or logical partition running AIX, the video that is displayed on the secondary monitor is the same as the video displayed the primary monitor, and at the same resolution and refresh rate.

The following table shows the feature code, custom card identification number, and field-replaceable unit part number for the adapter.

feature code (FC)	custom card identification number (CCIN)	field-replaceable unit (FRU) part number
5269	5269	74Y3227*
*Designed to comply with RoHS requirement		

This adapter provides the following features:

- 8-bit indexed or 24-bit true color.
- 32-MB SDRAM frame buffer.
- x1 PCIe bus interface.
- One DVI-I analog or digital connectors.
- One monitor connected, analog, up to 2048 x 1536 resolution.
- One monitor connected, digital, up to 1280 x 1024 resolution.
- A second monitor supported at up to 1600 x 1200 analog or 1280 x 1024 digital.
 - For systems or logical partitions running Linux, a second monitor is supported at resolutions up to 1600 x 1200 analog or 1280 x 1024 digital.
 - For systems or logical partitions running AIX, when running with two monitors, both monitors must have an analog connection with the same resolution, up to 1600 x 1200. The image on the primary monitor is also displayed on the secondary monitor.
- Display power management: Video Electronics Standards Association (VESA), Display Power Management Signaling (DPMS)

For details about slot priorities and placement rules, see the PCI adapter placement topic collection for your system.

Operating system or partition requirements

The adapter is supported under the following operating systems:

If you are installing a new feature, ensure that you have the software that is required to support the new feature and that you determine whether there are any prerequisites for this feature and attaching devices. To check for the prerequisites, see IBM Prerequisite website (www-912.ibm.com/e_dir/eServerPrereq.nsf).

This adapter is supported for the following versions of operating systems:

- AIX
 - AIX Version 7.1
 - AIX Version 6.1
 - AIX Version 5.3
- Linux
 - Red Hat Enterprise Linux
 - SUSE Linux Enterprise Server
 - See the Linux Alert site for the support details.

Preparing for installation

If you are installing the operating system at this time, install the adapter before you install the operating system. See “Installing the adapter” on page 44 for instructions. If you are installing only the device driver for this adapter, install the device driver software before you install the adapter. See “Installing the device driver software” on page 44 for instructions.

Gathering tools and documentation

To install the adapter, make sure that you have access to the following items:

- The adapter
- The operating system documentation
- The system service guide for removing and replacing features
- The PCI adapter placement documentation
- A flat-blade screwdriver
- The media containing the device driver software

Installing the device driver software

This section explains how to install device driver software for the adapter. The device driver is provided for the AIX 5L operating system.

To install device driver software, do the following steps:

1. Log in to the system unit as root user.
2. Insert the media containing the device driver software (for example, the CD) into the media device.
If your system does not have a CD-ROM drive, refer to your system documentation for performing a Network Installation Management (NIM) installation.
3. Type the following System Management Interface Tool (SMIT) fast path command: `smit devinst`
4. Press Enter. The Install Additional Device Software window highlights the **INPUT device / directory for software** option.
5. Type the name of the input device that you are using, or press F4 to select the input device from a list.
6. Press Enter. The Install Additional Device Software window highlights the SOFTWARE to install option.
7. Press F4 to select List.
8. Type / to display the Find window.
9. Type the device package name `devices.pci.2b102725`.
10. Press Enter. The system finds and highlights this device driver software.
11. Press F7 to select the highlighted device driver software.
12. Press Enter. The INSTALL ADDITIONAL DEVICE SOFTWARE window displays. The entry fields are automatically updated.
13. Press Enter to accept the information. The ARE YOU SURE window displays.
14. Press Enter to accept the information. The COMMAND STATUS window displays.
 - The message RUNNING is highlighted to indicate that the installation and configuration command is in progress.
 - When RUNNING changes to OK, scroll to the bottom of the page and locate the installation summary.
 - After a successful installation, SUCCESS displays in the Result column of the installation summary at the bottom of the page.
15. Remove the installation media from the drive.
16. Press F10 to exit SMIT.

Installing the adapter

This section explains how to install the adapter. If you are installing your operating system at this time, install your adapter before you install the operating system. If the operating system is already installed and you need to install the device driver for this adapter, install the device driver software before you install the adapter. See “Installing the device driver software” for instructions.

Attention: Before installing an adapter, review the precautions in Safety notices and Handling static sensitive devices. Do not remove the adapter from its anti-static package until you are ready to place it in the system unit.

To install the adapter, follow these steps:

1. Determine the PCIe slot in which to place the adapter.
The PCIe LP POWER GXT145 Graphics Accelerator adapter has an x1 PCIe connector and can be placed in a PCIe x1, x4, x8, or x16 slot. See PCI adapter placement for information about the PCIe slots on your system unit.
2. Shut down the system unit and install the adapter using the instructions in the system unit documentation.
3. Connect the converter cable to the adapter and the monitor cable.
If necessary, you can use a DVI-A dongle (feature code 4276) for connecting a VGA 15-pin connector on a monitor cable to the DVI connector on the adapter. For example, a DVI-A dongle is needed to connect to a 7316-TF3 console or a KVM switch.
4. Start the system unit and the monitor.
5. When prompted, configure the adapter by following the online configuration instructions.
6. When **Select Display** (console) appears, press the number key on your keyboard for the monitor that is to be the default.

Troubleshooting

If you have video problems after the initial installation, follow these procedures to troubleshoot the problem:

- Check the cables.
- Check the device driver software installation.
- Check the console.
- Check the adapter installation.

Checking the cables

1. Ensure the monitor cables are connected to the correct adapter.
2. If you have more than one video adapter, be sure that each adapter is connected to a monitor.
3. Verify that the connections are secure.
4. If no log-in prompt appears, restart the system unit.

Checking the device driver software installation

Verify that the device driver for the PCIe LP POWER GXT145 Graphics Accelerator adapter is installed by typing the following command and then pressing Enter:

```
lslpp -l all | grep GXT145
```

If the GXT145 device driver is installed, the following table is an example of the data that appears if you are running AIX Version 5.2:

```
devices.pci.2b102725.X11 5.2.0.105 COMMITTED AIXwindows GXT145 Graphics
devices.pci.2b102725.diag 5.2.0.105 COMMITTED GXT145 Graphics Adapter
devices.pci.2b102725.rte 5.2.0.105 COMMITTED GXT145 Graphics Adapter
```

If the POWER GXT145 device driver did not fully install, reinstall the driver. See “Installing the device driver software” on page 44.

Checking the console

1. If you continue to experience problems, you can redirect the monitor to the new adapter using the **chdisp** command.
2. If you continue to experience problems after you have checked your cables and tried the **chdisp** command, run diagnostics.

Checking the adapter installation

Verify that the system unit recognizes the PCIe LP POWER GXT145 Graphics Accelerator adapter.

At the AIX command-line type `lsdev -Cs pci`. If the PCIe LP POWER GXT145 Graphics Accelerator adapter is correctly installed, the following is an example of the data that appears:

```
cor0 Available 0K-00 GXT145 Graphics Adapter
```

If the message indicates that the adapter is DEFINED instead of AVAILABLE, shut down the system unit and check the PCIe LP POWER GXT145 Graphics Accelerator adapter to ensure that it is installed correctly. If you continue to experience problems after following the steps in this section, contact service and support for assistance.

Related tasks:

[Installing PCI adapters](#)

Related reference:

[IBM Prerequisite website](#)

[Parts information](#)

[PCI adapter placement](#)

“Backplane daughter cards and RAID enablement cards” on page 2

Find links to topics that cover Backplane daughter cards and RAID enablement cards.

PCIe2 LP 3D Graphics Adapter x1 (FC EC41)

Learn about the features, requirements, installation notes, and troubleshooting tips for the PCIe2 LP 3D Graphics Adapter.

Overview

The PCIe2 LP 3D Graphics Adapter is a PCI Express (PCIe) adapter that accelerates and enhances the system unit video. The adapter has no hardware switches to set. Mode selection is made through the software. Figure 17 on page 47 shows the adapter and its connectors.

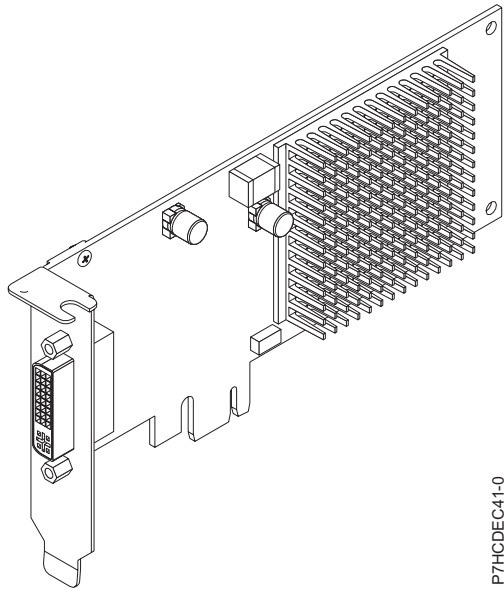

Figure 17. PCIe2 LP 3D Graphics Adapter

The following table shows the feature code, custom card identification number, and field-replaceable unit part number for the adapter.

Feature code (FC)	Custom card identification number (CCIN)	Field-replaceable unit (FRU) part number
EC41	NA	00E3980* Cable part number: 00E3060
*Designed to comply with RoHS requirement		

This adapter provides the following features:

- Placed in a single PCIe slot.
- The adapter is regular-height and of half-length.
- Supports the single lane (x1) PCIe 2.1 bus interface.
- Provides 512 MB DDR3 graphics memory.
- Supports DVI or VGA outputs.
- Supports two 30 inches (76.2 cm) high-resolution displays.
- Provides a DMS-59 connector that can attach to any DMS-59 breakout cable.
- One analog monitor connected that supports a maximum resolution of up to 1920 x 1200.
- One digital monitor connected that supports a maximum resolution of up to 2560 x 1600.
- Display power management: Video Electronics Standards Association (VESA), Display Power Management Signaling (DPMS)

For details about slot priorities and placement rules, see the PCI adapter placement topic collection for your system.

Operating system or partition requirements

If you are installing a new feature, ensure that you have the software that is required to support the new feature and that you determine whether there are any prerequisites for this feature and attaching devices. To check for the prerequisites, see IBM Prerequisite website (www-912.ibm.com/e_dir/eServerPrereq.nsf).

This adapter is supported for the following versions of the Linux operating system:

- For support details, see the Linux Alert website (www14.software.ibm.com/webapp/set2/sas/f/lopdiags/info/LinuxAlerts.html).
- Supported on Firmware level 7.8, or later

Preparing for installation

If you are installing the operating system at this time, install the adapter before you install the operating system. See “Installing the adapter” for instructions. If you are installing only the device driver for this adapter, install the device driver software before you install the adapter.

Gathering tools and documentation

To install the adapter, make sure that you have access to the following items:

- The adapter
- The operating system documentation
- The system service guide for removing and replacing features
- The PCI adapter placement documentation
- A flat-blade screwdriver
- The media containing the device driver software

Installing the adapter

This section explains how to install the adapter. If you are installing your operating system at this time, install your adapter before you install the operating system. If the operating system is already installed and you need to install the device driver for this adapter, install the device driver software before you install the adapter.

Attention: Before you install an adapter, review the precautions in Safety notices and Handling static sensitive devices. Do not remove the adapter from its anti-static package until you are ready to place it in the system unit.

To install the adapter, follow these steps:

1. Determine the PCIe slot in which to place the adapter.
The PCIe2 3D Graphics Adapter has an x1 PCIe connector and can be placed in a PCIe x1, x4, x8, or x16 slot. See PCI adapter placement for information about the PCIe slots on your system unit.
2. Shut down the system unit and install the adapter by using the instructions in the Installing PCI adapters topic for your system.
3. Connect the monitor cable to the adapter.
If necessary, you can use a DVI-59 dongle for connecting a VGA 15-pin connector on a monitor cable to the DVI connector on the adapter. For example, a DVI-59 dongle is needed to connect to a display (FC 3632), a rack-mounted 7316-TF4 console, or a KVM switch.
4. Start the system unit and the monitor.
5. When prompted, configure the adapter by following the online configuration instructions.
6. When **Select Display** (console) appears, press the number key on your keyboard for the monitor that is to be the default.

Troubleshooting

If you have video problems after the initial installation, follow these procedures to troubleshoot the problem:

- Check the cables.

- Check the device driver software installation.
- Check the adapter installation.

Checking the cables

1. Ensure the monitor cables are connected to the correct adapter.
2. If you have more than one video adapter, be sure that each adapter is connected to a monitor.
3. Verify that the connections are secure.
4. If no log-in prompt appears, restart the system unit.

Checking the device driver software installation

Verify that the device driver for the PCIe2 3D Graphics Adapter is installed.

Checking the adapter installation

Verify that the system unit recognizes the PCIe2 3D Graphics Adapter.

At the Linux command-line enter `lspci -vmm -k -d 1002:68f2`. If the PCIe2 3D Graphics Adapter is correctly installed, the following is an example of the data that appears:

```
Device: 0009:01:00.0
Class: VGA compatible controller
Vendor: Advanced Micro Devices, Inc. [AMD/ATI]
Device: Cedar GL [FirePro 2270]
SVendor: Advanced Micro Devices, Inc. [AMD/ATI]
SDevice: Device 0126
PhySlot: U78CB.001.WZS000T-P1-C2
Driver: radeon
```

If the adapter does not show up, verify your LPAR configuration. If the adapter does show up but you are experiencing issues related to this adapter, such as visual glitches, incorrect colors, no image displayed, slow or incorrect rendering, and other problems with the display, you can run the standalone diagnostics for the adapter available in the IBM Installation Toolkit for PowerLinux™.

If the message indicates that the adapter is DEFINED instead of AVAILABLE, shut down the system unit and check the PCIe2 3D Graphics Adapter to ensure that it is installed correctly. If you continue to experience problems after following the steps in this section, contact service and support for assistance.

IBM Installation Toolkit for PowerLinux

To troubleshoot problems for the 3D Graphics adapter, you can use the IBM Installation Toolkit for PowerLinux, a stand-alone diagnostic toolkit for systems that have the 3D Graphics adapter installed.

To diagnose problems with the 3D graphics adapter installed in a system, and work with the IBM Installation Toolkit, complete the following steps:

1. Download the DVD ISO image from IBM Installation Toolkit website (<http://www-304.ibm.com/webapp/set2/sas/f/lopdiags/installtools/home.html>).
2. Create a DVD for the downloaded ISO image.
3. Insert the DVD in the system DVD drive and boot the system.

Note: You can also use the NIM to boot the system.

4. Once the DVD has booted, select the 3D graphics diagnostics application.
5. Choose the option 2 - Wizard mode graphical (using X). The Graphical desktop is displayed.
6. Right-click on the desktop area, and click **IBM > PCIe2 3D Graphics Adapter**.

- Follow the on-screen instructions to diagnose the problem with the 3D Graphics adapter and resolve the problem.

POWER GXT145 PCI Express Graphics Accelerator (FC 5748; CCIN 5748)

Learn about the features, requirements, installation notes, and troubleshooting tips for the POWER GXT145 PCI Express Graphics Accelerator adapter.

Overview

The POWER GXT145 PCI Express Graphics Accelerator adapter is a PCI Express (PCIe) adapter that accelerates and enhances the system unit video. The adapter has no hardware switches to set. Mode selection is made through the software. Figure 18 shows the adapter and its connectors.

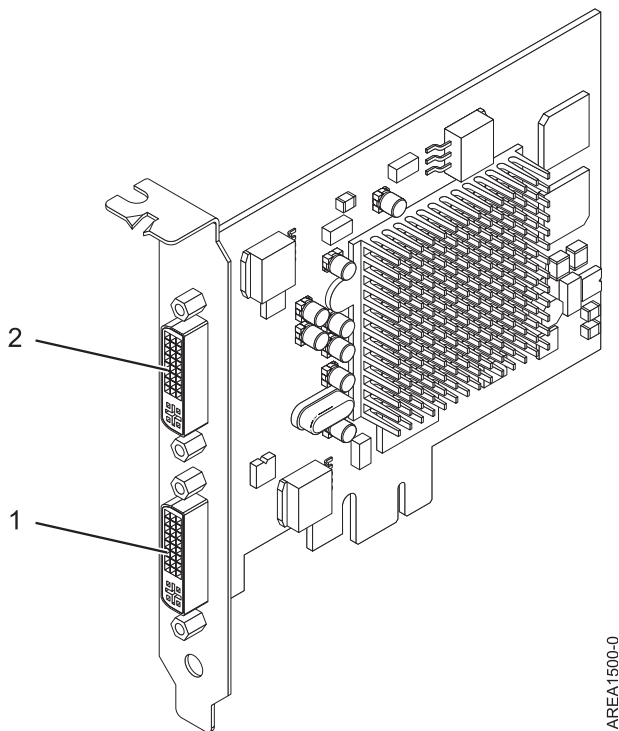

Figure 18. POWER GXT145 PCI Express Graphics Accelerator adapter

- Primary DVI connector (28 pin), analog, or digital
- Secondary DVI connector (28 pin), analog, or digital

Connect the primary monitor to connector 1. If you are using an optional, secondary monitor, connect the secondary monitor to connector 2. In the system or logical partition running AIX, the video that is displayed on the secondary monitor is the same as the video displayed the primary monitor, and at the same resolution and refresh rate.

The following table shows the feature code, custom card identification number, and field-replaceable unit part number for the adapter.

Feature code (FC)	Custom card identification number (CCIN)	Field-replaceable unit (FRU) part number
5748	5748	10N7756*

Feature code (FC)	Custom card identification number (CCIN)	Field-replaceable unit (FRU) part number
Designed to comply with RoHS requirement		

This adapter provides the following features:

- 8-bit indexed or 24-bit true color.
- 32-MB SDRAM frame buffer.
- x1 PCIe bus interface.
- Two DVI-I analog or digital connectors.
- One monitor connected, analog, up to 2048 x 1536 resolution.
- One monitor connected, digital, up to 1280 x 1024 resolution.
- A second monitor supported on secondary connector at up to 1600 x 1200 analog or 1280 x 1024 digital. A second monitor supported on secondary connector at up to 1600 x 1200 analog or 1280 x 1024 digital.
 - For systems or logical partitions running Linux, a second monitor is supported on the secondary connector at resolutions up to 1600 x 1200 analog or 1280 x 1024 digital.
 - For systems or logical partitions running AIX, when running with two monitors, both monitors must have an analog connection with the same resolution, up to 1600 x 1200. The image on the primary monitor is also displayed on the secondary monitor.
- Display power management: Video Electronics Standards Association (VESA), Display Power Management Signaling (DPMS)

For details about slot priorities and placement rules, see the PCI adapter placement topic collection for your system.

Operating system or partition requirements

The adapter is supported under the following operating systems:

If you are installing a new feature, ensure that you have the software that is required to support the new feature and that you determine whether there are any prerequisites for this feature and attaching devices. To check for the prerequisites, see IBM Prerequisite website (www-912.ibm.com/e_dir/eServerPrereq.nsf).

This adapter is supported for the following versions of operating systems:

- AIX
 - AIX Version 7.1
 - AIX Version 6.1
 - AIX Version 5.3
- Linux
 - Red Hat Enterprise Linux
 - SUSE Linux Enterprise Server
 - See the Linux Alert site for the support details.

Preparing for installation

If you are installing the operating system at this time, install the adapter before you install the operating system. See “Installing the adapter” on page 52 for instructions. If you are installing only the device driver for this adapter, install the device driver software before you install the adapter. See “Installing the device driver software” on page 52 for instructions.

Gathering tools and documentation

To install the adapter, make sure that you have access to the following items:

- The adapter
- The operating system documentation
- The system service guide for removing and replacing features
- The PCI adapter placement documentation
- A flat-blade screwdriver
- The media containing the device driver software

Installing the device driver software

This section explains how to install device driver software for the adapter. The device driver is provided for the AIX 5L operating system.

To install device driver software, do the following steps:

1. Log in to the system unit as root user.
2. Insert the media containing the device driver software (for example, the CD) into the media device.
If your system does not have a CD-ROM drive, refer to your system documentation for performing a Network Installation Management (NIM) installation.
3. Type the following System Management Interface Tool (SMIT) fast path command: `smit devinst`
4. Press Enter. The Install Additional Device Software window highlights the **INPUT device / directory for software** option.
5. Type the name of the input device that you are using, or press F4 to select the input device from a list.
6. Press Enter. The Install Additional Device Software window highlights the SOFTWARE to install option.
7. Press F4 to select List.
8. Type / to display the Find window.
9. Type the device package name `devices.pci.2b102725`.
10. Press Enter. The system finds and highlights this device driver software.
11. Press F7 to select the highlighted device driver software.
12. Press Enter. The INSTALL ADDITIONAL DEVICE SOFTWARE window displays. The entry fields are automatically updated.
13. Press Enter to accept the information. The ARE YOU SURE window displays.
14. Press Enter to accept the information. The COMMAND STATUS window displays.
 - The message RUNNING is highlighted to indicate that the installation and configuration command is in progress.
 - When RUNNING changes to OK, scroll to the bottom of the page and locate the installation summary.
 - After a successful installation, SUCCESS displays in the Result column of the installation summary at the bottom of the page.
15. Remove the installation media from the drive.
16. Press F10 to exit SMIT.

Installing the adapter

This section explains how to install the adapter. If you are installing your operating system at this time, install your adapter before you install the operating system. If the operating system is already installed

and you need to install the device driver for this adapter, install the device driver software before you install the adapter. See “Installing the device driver software” on page 52 for instructions.

Attention: Before installing an adapter, review the precautions in Safety notices and Handling static sensitive devices. Do not remove the adapter from its anti-static package until you are ready to place it in the system unit.

To install the adapter, follow these steps:

1. Determine the PCIe slot in which to place the adapter.
The POWER GXT145 PCI Express Graphics Accelerator adapter has an x1 PCIe connector and can be placed in a PCIe x1, x4, x8, or x16 slot. See PCI adapter placement for information about the PCIe slots on your system unit.
2. Shut down the system unit and install the adapter using the instructions in the system unit documentation.
3. Connect the monitor cable to the adapter.
If necessary, you can use a DVI-A dongle (feature code 4276) for connecting a VGA 15-pin connector on a monitor cable to the DVI connector on the adapter. For example, a DVI-A dongle is needed to connect to a 7316-TF3 console or a KVM switch.
4. Start the system unit and the monitor.
5. When prompted, configure the adapter by following the online configuration instructions.
6. When **Select Display** (console) appears, press the number key on your keyboard for the monitor that is to be the default.

Troubleshooting

If you have video problems after the initial installation, follow these procedures to troubleshoot the problem:

- Check the cables.
- Check the device driver software installation.
- Check the console.
- Check the adapter installation.

Checking the cables

1. Ensure the monitor cables are connected to the correct adapter.
2. If you have more than one video adapter, be sure that each adapter is connected to a monitor.
3. Verify that the connections are secure.
4. If no log-in prompt appears, restart the system unit.

Checking the device driver software installation

Verify that the device driver for the POWER GXT145 PCI Express Graphics Accelerator adapter is installed by typing the following command and then pressing Enter:

```
lslpp -l all | grep GXT145
```

If the GXT145 device driver is installed, the following table is an example of the data that appears if you are running AIX Version 5.2:

```
devices.pci.2b102725.X11 5.2.0.105 COMMITTED AIXwindows GXT145 Graphics
devices.pci.2b102725.diag 5.2.0.105 COMMITTED GXT145 Graphics Adapter
devices.pci.2b102725.rte 5.2.0.105 COMMITTED GXT145 Graphics Adapter
```

If the POWER GXT145 device driver did not fully install, reinstall the driver. See “Installing the device driver software” on page 52.

Checking the console

1. If you continue to experience problems, you can redirect the monitor to the new adapter using the **chdisp** command.
2. If you continue to experience problems after you have checked your cables and tried the **chdisp** command, run diagnostics.

Checking the adapter installation

Verify that the system unit recognizes the POWER GXT145 PCI Express Graphics Accelerator adapter.

At the AIX command-line type `lsdev -Cs pci`. If the POWER GXT145 PCI Express Graphics Accelerator adapter is correctly installed, the following is an example of the data that appears:

```
cor0 Available 0K-00 GXT145 Graphics Adapter
```

If the message indicates that the adapter is DEFINED instead of AVAILABLE, shut down the system unit and check the POWER GXT145 PCI Express Graphics Accelerator adapter to ensure that it is installed correctly. If you continue to experience problems after following the steps in this section, contact service and support for assistance.

Related tasks:

[Installing PCI adapters](#)

Related reference:

[IBM Prerequisite website](#)

[Parts information](#)

[PCI adapter placement](#)

“Backplane daughter cards and RAID enablement cards” on page 2

Find links to topics that cover Backplane daughter cards and RAID enablement cards.

PCIe2 LP 4-port (10Gb+1GbE) Copper SFP+RJ45 Adapter (FC EN0V; CCIN 2CC3)

Learn about the specifications and operating system requirements for the feature code (FC) EN0V adapter.

Overview

The PCIe2 LP 4-port (10Gb+1GbE) Copper SFP+RJ45 Adapter is a PCI Express (PCIe) generation 2, x8, short form-factor, low-profile adapter. The adapter provides two 10 Gb copper twinax small form-factor pluggable (SFP+) ports and two 1 Gb RJ45 ports. This adapter provides a PCIe 2.0 host bus interface. The adapter supports the Ethernet network interface controller (NIC) function. The adapter is a high-performance adapter that consolidates traffic for networking. The link aggregation and failover features of the adapter make it suitable for critical network applications that require redundancy and high availability.

The two 10 Gb are SFP+ and do not include a transceiver. Active Copper twinax cables up to 5 meter in length are supported such as provided by feature codes EN01, EN02 or EN03. A transceiver is included with these cables. See “Cables” on page 57 for details. Each 10 Gb port provides Ethernet connectivity with a nominal data rate of 10 Gbps (gigabits per second). Figure 19 on page 56 shows the FC EN0V adapter.

Each of the 1 Gb RJ45 port provides Ethernet connectivity at a data rate of 1 Gbps. Each of the 1 Gb ports is connected with a 4-pair, CAT-5 unshielded twisted pair (UTP) cable or with a cable of higher specification, and is supported for distances of up to 100 meters. In addition to 1 Gb (1000 Mb) networks, 100 Mb networks are also supported.

The adapter provides the following features:

- The adapter is a PCIe2 NIC network convergence adapter.
- The 10 Gb ports can function in the NIC mode.
- The adapter can be used as the host local area network (LAN) adapter.
- The adapter supports interrupt moderation to deliver increased performance while significantly reducing processor utilization
- The adapter supports dual port operation in any PCIe3 or PCIe2 slot.
- The adapter supports auto-negotiation, full-duplex only.
- The adapter supports multiple media-access control (MAC) per interface.
- The adapter supports integrated media-access control (MAC) and physical layer (PHY).
- The adapter supports the following standards for the different ports and functions:
 - IEEE 802.3ae in the 10 GbE ports
 - 802.3ab in the 1 GbE ports
 - Ether II and IEEE 802.3 for encapsulated frames
 - 802.1p for setting up priority levels in tagged VLAN frames
 - 802.1Q for VLAN tagging
 - 802.3x for flow control
 - 802.3ad for load-balancing and failover
 - IEEE 802.3ad and 802.3 for link aggregation
- The adapter provides message signal interrupts (MSI), MSI-X, and support of legacy pin interrupts.
- The adapter supports jumbo frames up to 9.6 KB.
- The adapter supports gigabit EtherChannel (GEC) with the existing software.
- The adapter supports TCP checksum offload transmission control protocol (TCP), user datagram protocol (UDP), TCP segmentation Offload (TSO) for IPv4 and IPv6.
- Supports TCP segmentation or large send offload
- Supports EEPROM-SPI and single EEPROM
- Compliant with European Union Directive 2002/95/EC on the Restriction of the Use of Certain Hazardous Substances in Electrical and Electronic Equipment

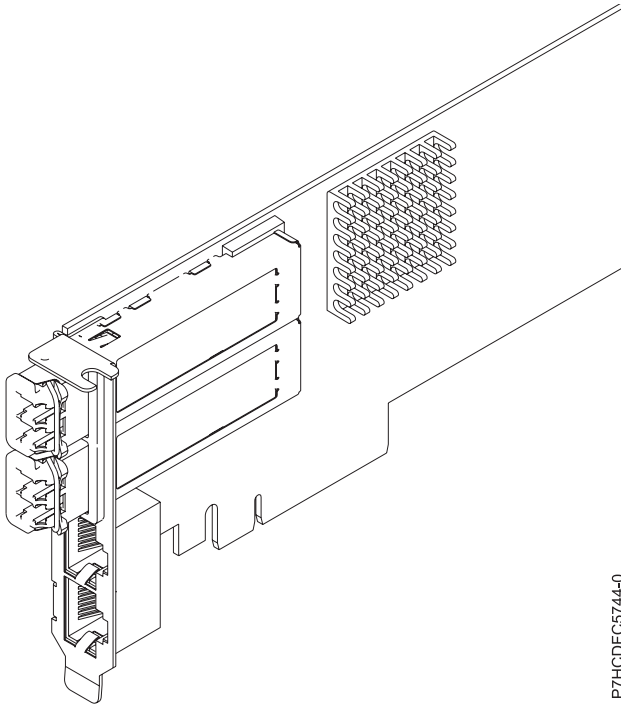

Figure 19. FC EN0V adapter

Specifications

Item Description

Adapter FRU number

00E2715 (Designed to comply with RoHS requirement)

Low-profile tailstock part number: 00E2720

Wrap plug FRU number

12R9314 (SFP+ SR wrap plug)

74Y7010 (Twinax wrap plug)

10N7405 (1 Gb UTP wrap plug)

I/O bus architecture

PCIe2 x8

Slot requirement

For details about slot priorities and placement rules, see the PCI adapter placement topic collection for your system.

Cables

See “Cables” on page 57 for details.

Voltage

3.3 V

Form factor

Short, low-profile

Maximum number

For details about the maximum number of adapters that are supported, see the PCI adapter placement topic collection for your system.

Cables

This adapter feature requires the use of compatible SFP+, 10 Gbps, copper, twinaxial, active, Ethernet cables. See Figure 20 for a view of the cable top and cable bottom. These cables are compliant with industry standard specifications SFF-8431 Rev 4.1 and SFF-8472 Rev 10.4, and all applicable IBM requirements.

Note: These cables are EMC Class A compliant.

See Table 21 for details about the feature codes.

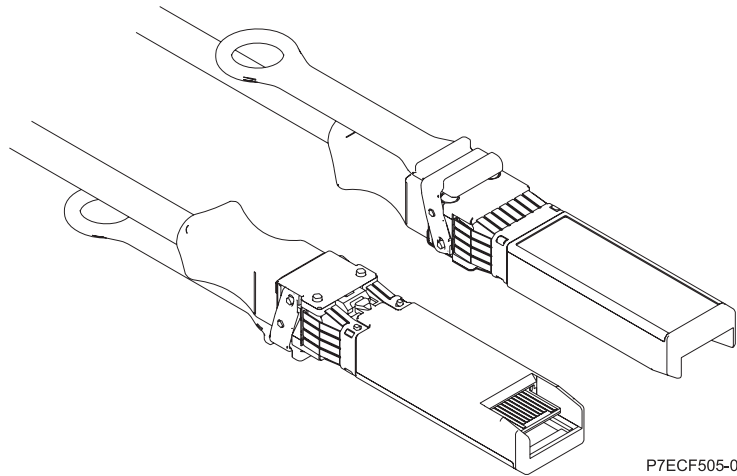

Figure 20. Top and bottom view of the cable

Table 21. Feature code and part number for varying lengths of the cable

Cable length	1 m (3.28 ft)	3 m (9.84 ft)	5 m (16.4 ft)
Feature code	EN01	EN02	EN03
CCIN	EF01	EF02	EF03
Part number	46K6182	46K6183	46K6184

Operating system or partition requirements

If you are installing a new feature, ensure that you have the software that is required to support the new feature and that you determine whether there are any prerequisites for this feature and attaching devices. To check for the prerequisites, see IBM Prerequisite website (www-912.ibm.com/e_dir/eServerPrereq.nsf).

The adapter is supported on the following versions of the operating systems:

- AIX
 - AIX 6.1 with the 6100-09 Technology Level and Service Pack 3 and APAR IV56366, or later
 - AIX 7.1 with the 7100-03 Technology Level and Service Pack 3 and APAR IV56367, or later
 - AIX 7.1 with the 7100-01 Technology Level and Service Pack 10, or later
 - AIX 7.1 with the 7100-02 Technology Level and Service Pack 5, or later
 - AIX 6.1 with the 6100-07 Technology Level and service Pack 10, or later
 - AIX 6.1 with the 6100-08 Technology Level and service Pack 5, or later
- Linux

- SUSE Linux Enterprise Server Version 11 Service Pack 3, or later, with current maintenance updates available from SUSE
- Red Hat Enterprise Linux Version 6.5, or later, with current maintenance updates available from Red Hat
- Red Hat Enterprise Linux Version 7, or later, with current maintenance updates available from Red Hat
- For support details, see the Linux Alert website (www14.software.ibm.com/webapp/set2/sas/f/lopdiags/info/LinuxAlerts.htm)
- IBM i supported through VIOS
 - IBM i Version 7.1, or later, supported through VIOS 2.2.2, or later

This adapter requires the following drivers:

- AIX: `devices.pciex.e4148a1614109304` for SFP+ optical ports and `devices.pciex.e4148a1614109404` for RJ45 ports
- Linux: `bnx2x` driver
- The latest version of the device driver or `iprutils` can be downloaded from IBM Service and Productivity Tools website (<http://www14.software.ibm.com/webapp/set2/sas/f/lopdiags/home.html>).

Related tasks:

[Installing PCI adapters](#)

Related reference:

[IBM Prerequisite website](#)

[Parts information](#)

[PCI adapter placement](#)

“Backplane daughter cards and RAID enablement cards” on page 2

Find links to topics that cover Backplane daughter cards and RAID enablement cards.

PCIe2 LP 4-Port (10Gb+1GbE) SR+RJ45 Adapter (FC EN0T; CCIN 2CC3)

Learn about the specifications and operating system requirements for the feature code (FC) EN0T adapter.

Overview

The PCIe2 LP 4-Port (10Gb+1GbE) SR+RJ45 Adapter is a PCI Express (PCIe) generation 2, x8, short form-factor, low-profile adapter. The adapter provides two 10 Gb SR optical ports and two 1 Gb RJ45 ports. This adapter provides a PCIe 2.0 host bus interface. The adapter supports the Ethernet network interface controller (NIC) function. The adapter is a high-performance adapter that consolidates traffic for networking. The link aggregation and failover features of the adapter make it suitable for critical network applications that require redundancy and high availability.

The four-port adapter provides two 10 Gb small form-factor pluggable (SFP+) optical SR transceiver ports and two 1 Gb RJ45 Ethernet ports. The two 10 Gb SR ports have little connector (LC) duplex-type connectors. The optical transceiver uses shortwave laser optics and is attached with MMF-850nm fiber cabling with LC connectors. See “Cables” on page 60 for more information about the optical cables. Each 10 Gb port provides Ethernet connectivity with a nominal data rate of 10 Gbps (gigabits per second). Figure 21 on page 60 shows the FC EN0T adapter.

Each of the 1 Gb RJ45 port provides Ethernet connectivity at a data rate of 1 Gbps. Each of the 1 Gb ports is connected with a 4-pair, CAT-5 unshielded twisted pair (UTP) cable or with a cable of higher specification, and is supported for distances of up to 100 meters. In addition to 1 Gb (1000 Mb) networks, 100 Mb networks are also supported.

The adapter provides the following features:

- The adapter is a PCIe2 NIC network convergence adapter.
- The 10 Gb SR ports can function in the NIC mode.
- The adapter can be used as the host local area network (LAN) adapter.
- The adapter supports interrupt moderation to deliver increased performance while significantly reducing processor utilization
- The adapter supports dual port operation in any PCIe3 or PCIe2 slot.
- The adapter supports auto-negotiation, full-duplex only.
- The adapter supports multiple media-access control (MAC) per interface.
- The adapter supports integrated media-access control (MAC) and physical layer (PHY).
- The adapter supports the following standards for the different ports and functions:
 - IEEE 802.3ae in the 10 GbE ports
 - 802.3ab in the 1 GbE ports
 - Ether II and IEEE 802.3 for encapsulated frames
 - 802.1p for setting up priority levels in tagged VLAN frames
 - 802.1Q for VLAN tagging
 - 802.3x for flow control
 - 802.3ad for load-balancing and failover
 - IEEE 802.3ad and 802.3 for link aggregation
- The adapter provides message signal interrupts (MSI), MSI-X, and support of legacy pin interrupts.
- The adapter supports jumbo frames up to 9.6 KB.
- The adapter supports gigabit EtherChannel (GEC) with the existing software.
- The adapter supports TCP checksum offload transmission control protocol (TCP), user datagram protocol (UDP), TCP segmentation Offload (TSO) for IPv4 and IPv6.
- Supports TCP segmentation or large send offload
- Supports EEPROM-SPI and single EEPROM
- Compliant with European Union Directive 2002/95/EC on the Restriction of the Use of Certain Hazardous Substances in Electrical and Electronic Equipment

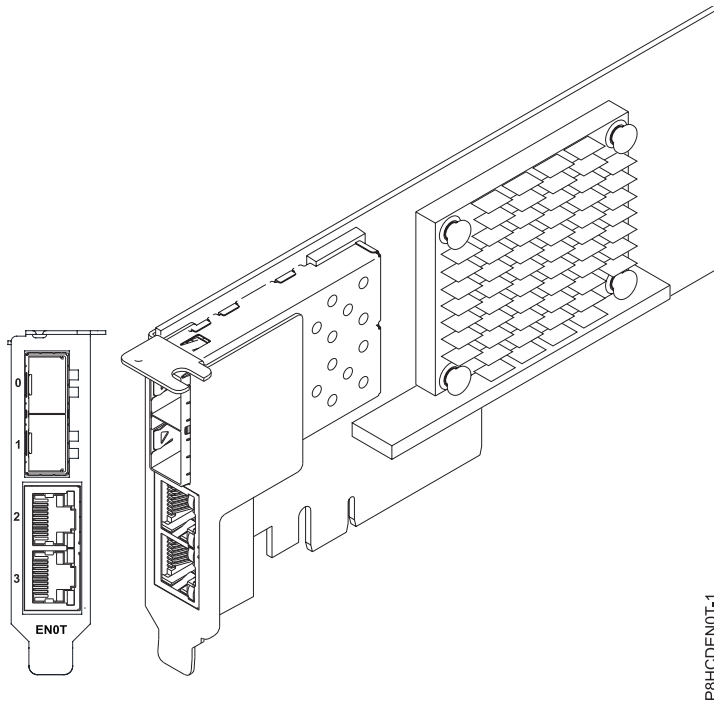

Figure 21. FC EN0T adapter

Specifications

Item Description

Adapter FRU number

00E2715 (Designed to comply with RoHS requirement)

Low-profile tailstock part number: 00E2720

Wrap plug FRU number

12R9314 (SFP+ SR wrap plug)

74Y7010 (Twinax wrap plug)

10N7405 (1 Gb UTP wrap plug)

I/O bus architecture

PCIe2 x8

Slot requirement

For details about slot priorities and placement rules, see the PCI adapter placement topic collection for your system.

Cables

See "Cables" for details.

Voltage

3.3 V

Form factor

Short, low-profile

Maximum number

For details about the maximum number of adapters that are supported, see the PCI adapter placement topic collection for your system.

Cables

Use multimode fiber optic cables with shortwave lasers that adhere to the following specifications:

- OM3 or OM4: Multimode 50/125 micron fiber, 2000 MHz x km bandwidth

- OM2: Multimode 50/125 micron fiber, 500 MHz x km bandwidth
- OM1: Multimode 62.5/125 micron fiber, 200 MHz x km bandwidth

Because core sizes are different, OM1 cables only can be connected to other OM1 cables. For best results, OM2 cables must not be connected to OM3 or OM4 cables. However, if an OM2 cable is connected to an OM3 or OM4 cable, the characteristics of the OM2 cable apply to the entire length of the cables. The following table shows the supported distances for the different fiber optic cable types at different link speeds.

Table 22. Supported distances for multimode fiber optic cables

Header	Cable Type and Distance		
Rate	OM1	OM2	OM3
10 Gbps	0.5 meters to 33 meters (1.64 feet to 108.26 feet)	0.5 meters to 82 meters (1.64 feet to 269.02 feet)	0.5 meters to 300 meters (1.64 feet to 984.25 feet)

Operating system or partition requirements

If you are installing a new feature, ensure that you have the software that is required to support the new feature and that you determine whether there are any prerequisites for this feature and attaching devices. To check for the prerequisites, see IBM Prerequisite website (www-912.ibm.com/e_dir/eServerPrereq.nsf).

The adapter is supported on the following versions of the operating systems:

- AIX
 - AIX 6.1 with the 6100-09 Technology Level and Service Pack 3 and APAR IV56366, or later
 - AIX 7.1 with the 7100-03 Technology Level and Service Pack 3 and APAR IV56367, or later
 - AIX 7.1 with the 7100-01 Technology Level and Service Pack 10, or later
 - AIX 7.1 with the 7100-02 Technology Level and Service Pack 5, or later
 - AIX 6.1 with the 6100-07 Technology Level and service Pack 10, or later
 - AIX 6.1 with the 6100-08 Technology Level and service Pack 5, or later
- Linux
 - SUSE Linux Enterprise Server Version 11 Service Pack 3, or later, with current maintenance updates available from SUSE
 - Red Hat Enterprise Linux Version 6.5, or later, with current maintenance updates available from Red Hat
 - Red Hat Enterprise Linux Version 7, or later, with current maintenance updates available from Red Hat
 - For support details, see the Linux Alert website (www14.software.ibm.com/webapp/set2/sas/f/lopdiags/info/LinuxAlerts.htm)
- IBM i supported through VIOS
 - IBM i Version 7.1, or later, supported through VIOS 2.2.2, or later

This adapter requires the following drivers:

- AIX: `devices.pciex.e4148a1614109304` for SFP+ optical ports and `devices.pciex.e4148a1614109404` for RJ45 ports
- Linux: `bnx2x` driver
- The latest version of the device driver or `iprutils` can be downloaded from IBM Service and Productivity Tools website (<http://www14.software.ibm.com/webapp/set2/sas/f/lopdiags/home.html>).

Related tasks:

 Installing PCI adapters

Related reference:

[IBM Prerequisite website](#)

[Parts information](#)

[PCI adapter placement](#)

“Backplane daughter cards and RAID enablement cards” on page 2

Find links to topics that cover Backplane daughter cards and RAID enablement cards.

PCIe2 LP 2-port 10 GbE BaseT RJ45 Adapter (FC EN0X; CCIN 2CC4)

Learn about the specifications and operating system requirements for the feature code (FC) EN0X adapter.

Overview

The PCIe2 LP 2-port 10 GbE BaseT RJ45 Adapter is a PCI Express (PCIe) generation 2, x8, short form-factor, low-profile adapter. The adapter provides two 10 Gb RJ45 ports. This adapter provides a PCIe 2.0 host bus interface. The adapter supports the Ethernet network interface controller (NIC) function. The adapter is a high-performance adapter that consolidates traffic for networking. The link aggregation and failover features of the adapter make it suitable for critical network applications that require redundancy and high availability. Figure 22 on page 63 shows the FC EN0X adapter.

The ports default to auto negotiate the highest speed either at 10 Gb (10G BaseT), 1Gb (1000 BaseT), or 100 Mb (100 BaseT) full duplex. Each RJ45 port can be configured independent of the other port. Each RJ45 port is connected with a 4-pair, CAT-6A cable, and is supported for distances of up to 100 meters.

The adapter provides the following features:

- The adapter is a PCIe2 NIC network convergence adapter.
- The 10 Gb RJ45 ports can function in the NIC mode.
- The adapter can be used as the host local area network (LAN) adapter.
- The adapter supports interrupt moderation to deliver increased performance while significantly reducing processor utilization
- The adapter supports dual port operation in any PCIe3 or PCIe2 slot.
- The adapter supports auto-negotiation, full-duplex only.
- The adapter supports multiple media-access control (MAC) per interface.
- The adapter supports integrated media-access control (MAC) and physical layer (PHY).
- The adapter supports the following standards for the different ports and functions:
 - IEEE 802.3ae in the 10 GbE ports
 - 802.3ab in the 1 GbE ports
 - Ether II and IEEE 802.3 for encapsulated frames
 - 802.1p for setting up priority levels in tagged VLAN frames
 - 802.1Q for VLAN tagging
 - 802.3x for flow control
 - 802.3ad for load-balancing and failover
 - IEEE 802.3ad and 802.3 for link aggregation
- The adapter provides message signal interrupts (MSI), MSI-X, and support of legacy pin interrupts.
- The adapter supports jumbo frames up to 9.6 KB.
- The adapter supports gigabit EtherChannel (GEC) with the existing software.
- The adapter supports TCP checksum offload transmission control protocol (TCP), user datagram protocol (UDP), TCP segmentation Offload (TSO) for IPv4 and IPv6.
- Supports TCP segmentation or large send offload

- Supports EEPROM-SPI and single EEPROM
- Compliant with European Union Directive 2002/95/EC on the Restriction of the Use of Certain Hazardous Substances in Electrical and Electronic Equipment

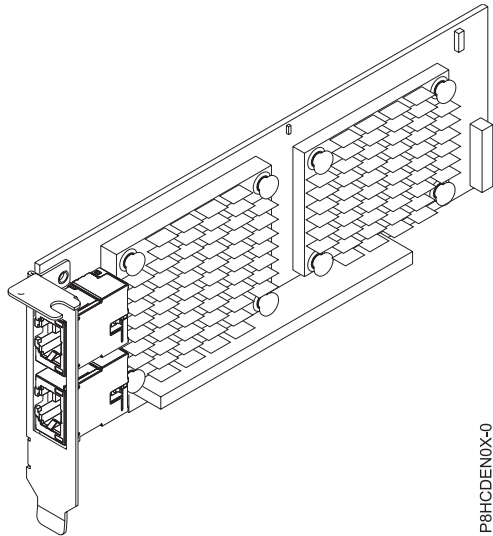

Figure 22. FC EN0X adapter

Specifications

Item Description

Adapter FRU number

00E2714 (Designed to comply with RoHS requirement)

Low-profile tailstock part number: 00E2721

Wrap plug FRU number

10N7405 (RJ45 wrap plug)

I/O bus architecture

PCIe2 x8

Slot requirement

For details about slot priorities and placement rules, see the PCI adapter placement topic collection for your system.

Cables

CAT-6A cable

Voltage

3.3 V

Form factor

Short, low-profile

Maximum number

For details about the maximum number of adapters that are supported, see the PCI adapter placement topic collection for your system.

Operating system or partition requirements

If you are installing a new feature, ensure that you have the software that is required to support the new feature and that you determine whether there are any prerequisites for this feature and attaching devices. To check for the prerequisites, see IBM Prerequisite website (www-912.ibm.com/e_dir/eServerPrereq.nsf).

The adapter is supported on the following versions of the operating systems:

- AIX
 - AIX 6.1 with the 6100-09 Technology Level and Service Pack 3 and APAR IV56366, or later
 - AIX 7.1 with the 7100-03 Technology Level and Service Pack 3 and APAR IV56367, or later
 - AIX 7.1 with the 7100-01 Technology Level and Service Pack 10, or later
 - AIX 7.1 with the 7100-02 Technology Level and Service Pack 5, or later
 - AIX 6.1 with the 6100-07 Technology Level and service Pack 10, or later
 - AIX 6.1 with the 6100-08 Technology Level and service Pack 5, or later
- Linux
 - SUSE Linux Enterprise Server Version 11 Service Pack 3, or later, with current maintenance updates available from SUSE
 - Red Hat Enterprise Linux Version 6.5, or later, with current maintenance updates available from Red Hat
 - Red Hat Enterprise Linux Version 7, or later, with current maintenance updates available from Red Hat
 - For support details, see the Linux Alert website (www14.software.ibm.com/webapp/set2/sas/f/lopdiags/info/LinuxAlerts.htm)
- IBM i supported through VIOS
- VIOS
 - VIOS 2.2.3.3 with ifix IV56366, or later
 - VIOS 2.2.2.5, or later
 - VIOS 2.2.1.9, or later

This adapter requires the following drivers:

- Linux: bnx2x driver
- The latest version of the device driver or iprutils can be downloaded from IBM Service and Productivity Tools website (<http://www14.software.ibm.com/webapp/set2/sas/f/lopdiags/home.html>).

Related tasks:

 [Installing PCI adapters](#)

Related reference:

 [IBM Prerequisite website](#)

 [Parts information](#)

 [PCI adapter placement](#)

“Backplane daughter cards and RAID enablement cards” on page 2

Find links to topics that cover Backplane daughter cards and RAID enablement cards.

PCIe3 RAID SAS quad-port 6 Gb Adapter (FC EJ0J; CCIN 57B4)

Learn about the specifications and operating system requirements for the feature code (FC) EJ0J adapter.

Overview

The PCIe3 RAID SAS quad-port 6 Gb Adapter is a PCI Express (PCIe), generation 3, RAID SAS adapter that has a low-profile, short-form factor, but packaged for full height installation. The adapter is used in high-performance and high-density, serial attached SCSI (SAS) applications. It supports the attachment of SAS disk and SAS tape by using four mini SAS high-density (HD) x4 connectors that allow the physical links to be used in various narrow and wide-port configurations. SAS tape attachment is only supported in a single adapter configuration and cannot be mixed with SAS disk on the same adapter. The adapter does not have write cache. Figure 23 on page 65 shows the PCIe3 RAID SAS quad-port 6 Gb Adapter.

The adapter is a 64 bit, 3.3 V, bootable SAS adapter that provides RAID 0, 5, 6, and 10 capability, and system level mirroring via the operating system. The adapter provides both single and dual RAID controller configurations. Dual controller configurations (dual storage IOA) must run RAID. JBOD (512 byte) functionality is supported only in a single controller configuration based on the operating system. Best performance is achieved when multiple RAID sets are configured and optimized under a pair of adapters in a high availability, multi-initiator RAID configuration (dual storage IOA) which allows for an Active-Active mode of operation.

The adapter support a maximum of 98 attached disk devices that depends on the drive enclosure attached. A maximum of 48 devices can be solid-state devices (SSDs). Externally attached devices are designed to run at a maximum data rate of 6 Gbps for SAS disk devices and 3 Gbps for SAS tape devices. This adapter supports RAID and non-RAID DASD, and SAS tape devices. Specific device attachment support rules apply. This adapter supports the multi-initiator and high availability (dual storage IOA) configurations in AIX, IBM i, and Linux partitions.. This adapter enables configuring the SAS drives as dedicated hot-spares with equal or higher capacity.

Important: See the SAS RAID controllers for AIX, SAS RAID controllers for Linux, or SAS RAID controllers for IBM i topics for more information and important considerations for multi-initiator and high availability or dual storage IOA configurations

Figure 23 shows the adapter. The connector plug (A) is installed in an empty port and prevents damage to that port whenever a cable for the adjacent port connectors is plugged-in or removed.

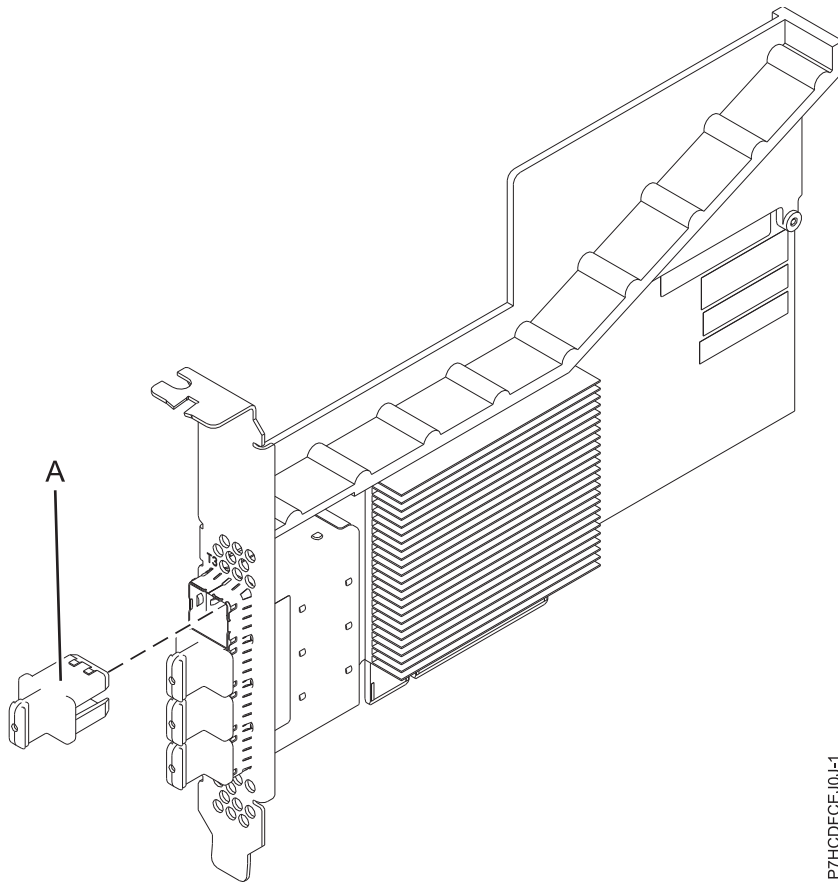

Figure 23. PCIe3 RAID SAS adapter

Specifications

Item Description

Adapter FRU number

00E7167 (Designed to comply with RoHS requirement)

Connector plug part number

00FW784 (The connector plug is installed in an empty port and prevents damage to that port whenever a cable for the adjacent port connectors is plugged-in or removed.)

I/O bus architecture

PCIe 3.0 but compatible to PCIe 2.0 or PCIe 1.0 slots.

Slot requirement

One available PCIe x8 slot per adapter.

Cables

Specific X, YO, AA, or AT SAS cable features with new narrow HD connectors are used to attach to the other adapter or disk expansion drawers.

SAS device attachment requires specific cables that are provided with the subsystem or device features that are being attached. Special cabling is required for multi-initiator and high availability configurations. Specific AE1 or YE1 SAS cable features are required for SAS Tape attachment. See Serial attached SCSI cable planning.

Voltage

3.3 V

Form factor

Short, low-profile but packaged for full-height installations.

Maximum number

For the maximum adapters supported, see the PCI adapter placement topic collection for your system.

Attributes

- Four external mini SAS HD 4x connectors provide attachment of SAS device enclosures
- SAS Serial SCSI Protocol (SSP) and Serial Management Protocol (SMP)
- RAID 0, 5, 6, or 10 with hot-spare capability. System level mirroring through the operating system is also supported. JBOD functionality (512 byte) is supported in a single controller configuration only.
- Concurrent firmware update
- Removable media device (SAS Tape) are supported in a single controller configuration only and cannot be combined with disk devices attached to the same adapter. Removable media is not supported in multi-initiator and high availability (dual storage IOA) configurations
- Support for multi-initiator and high availability or single controller configurations

Operating system or partition requirements

If you are installing a new feature, ensure that you have the software that is required to support the new feature and that you determine whether there are any prerequisites for this feature and attaching devices. To check for the prerequisites, see IBM Prerequisite website (www-912.ibm.com/e_dir/eServerPrereq.nsf).

The adapter is supported on the following versions of the operating systems:

- AIX
 - AIX Version 7.1, or later.
 - AIX Version 6.1, or later.
- Linux
 - Red Hat Enterprise Linux 6.4, or later.
 - SUSE Linux Enterprise Server 11 Service Pack 3, or later.
 - The latest version of iprutils can be downloaded from IBM Service and Productivity Tools website (<http://www14.software.ibm.com/webapp/set2/sas/f/lopdiags/home.html>).
- IBM i

- IBM i 7.1 (with TR7), or later.
- IBM i 6.1 (with 6.1.1-M Machine Code), or later.
- Supported on Firmware level 7.8, or later.

This adapter requires the following drivers:

- AIX: devices.pci.14104A0 device driver package

PCIe3 12 GB Cache RAID SAS quad-port 6 Gb Adapter (FC EJ0L; CCIN 57CE)

Learn about the specifications and operating system requirements for the feature code (FC) EJ0L adapters.

Overview

The PCI Express (PCIe) generation 3, 12 GB Cache RAID SAS quad-port 6 Gb Adapter is a large cache PCIe3 SAS adapter that provides high-performance capabilities and supports the attachment of serial-attached SCSI (SAS) disks and SAS solid-state drives (SSDs) through four mini SAS high-density (HD) connectors. The feature code (FC) EJ0L has up to a 12 GB write-cache via compression. The adapter is a 64 bit, 3.3 V, bootable SAS adapter that supports RAID levels 0, 5, 6, and 10 as well as system level mirroring via the operating system. The adapter must be installed in pairs and must be used in a high availability, multi-initiator RAID configuration with two adapters in dual-controller mode (dual storage IOA configuration). Two FC EJ0L adapters provide additional performance and adapter redundancy with mirrored write-cache data and mirrored RAID parity footprints between the adapters. If the FC EJ0L pairing is broken, then the write cache is disabled. Integrated flash memory with capacitors provides protection of the write cache in case of power failure, without the need for batteries as were used with some previous large cache adapters.

Figure 24 on page 68 shows the PCIe3 12 GB Cache RAID SAS quad-port 6 Gb adapter. The connector plug (A) is installed in an empty port and prevents damage to that port whenever a cable for the adjacent port connectors is plugged-in or removed.

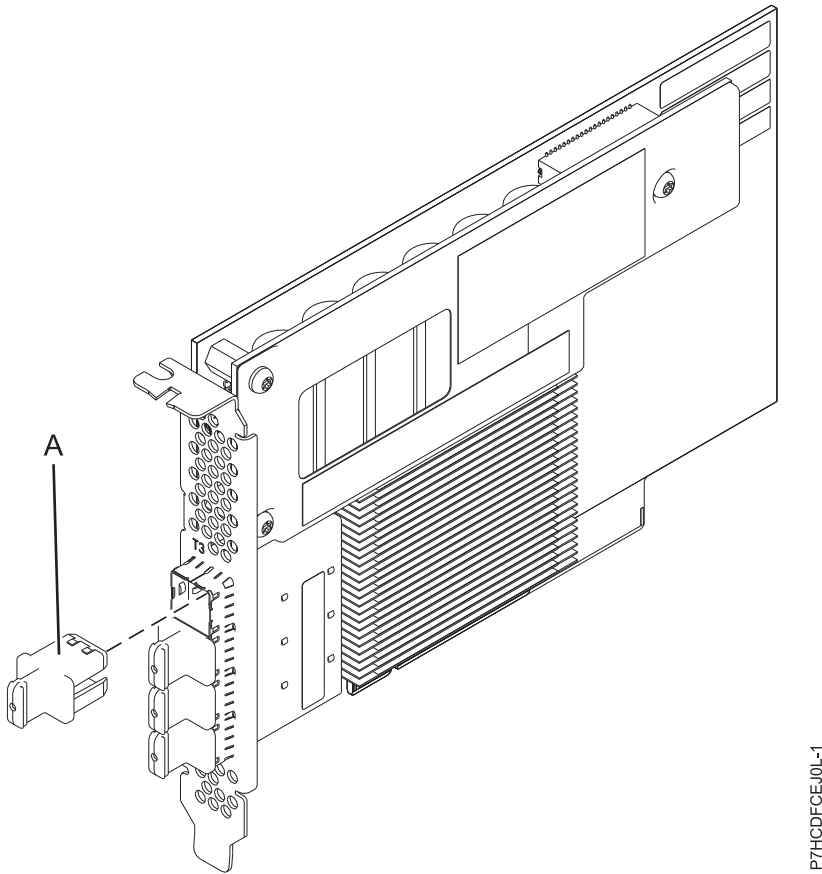

Figure 24. PCIe3 12 GB Cache RAID SAS 6 Gb Adapter

To provide the highest bandwidth between two paired feature EJ0L adapters for the mirroring of cache data and parity update footprints, two SAS Adapter-to-Adapter (AA) cables are required by default on the third and fourth adapter ports until maximum device quantity attachment is required. When all connectors are attaching SAS drives, the communication between the adapter pair is performed through the SAS fabric via the I/O drawer and cabling.

The FC EJ0L is a single wide, full-height, short adapter. Figure 24 shows the FC EJ0L adapter. Every FC EJ0L requires another FC EJ0L on this server, or on another server, which pairs with the SAS RAID adapter and enables cache functionality and the other multi-initiator high availability (dual storage IOA) functions.

Systems running the AIX or Linux operating systems support either having both EJ0L features in the same system or partition, or in two separate systems or partitions. Systems running the IBM i operating system do not support the pairing of adapters on different servers or different partitions, so both the EJ0L features must be installed on the same system or partition.

For details about slot priorities and placement rules, see the PCI adapter placement topic collection for your system.

Specifications

Item	Description
Adapter FRU number	00FX840 (Designed to comply with RoHS requirement)

Connector plug part number

00FW784 (The connector plug is installed in an empty port and prevents damage to that port whenever a cable for the adjacent port connectors is plugged-in or removed.)

I/O bus architecture

PCIe 3.0 but downward compatible to 2.0 and 1.0

Slot requirement

One PCIe x8 slot per adapter.

Adapters are installed in pairs.

For higher availability, place adapters in separate enclosures where supported.

Cables

Specific X , YO, AA, or AT SAS cable features with new narrow HD connectors are used to attach to the other adapter or expansion drawers.

SAS device attachment requires specific cables that are provided with the subsystem or device features being attached. Special cabling is required for multi-initiator and high availability configurations. See Serial attached SCSI cable planning.

Voltage

3.3 V

Form factor

Short, full-height

Maximum number

For the maximum adapters supported, see the PCI adapter placement topic collection for your system.

Attributes provided

- Support of the SAS Serial SCSI Protocol (SSP) and Serial Management Protocol (SMP).
- Provides RAID 0, RAID 5, RAID 6, and RAID 10 with hot-spare capability. System level mirroring through the operating system is also supported. JBOD functionality (512 byte) is not supported except for the initial formatting to 528 bytes of new devices, as required.
- Double looping of the I/O enclosure system connection is suggested to enhance performance when more than four adapters are installed in either FC 5803 or FC 5873.

Operating system or partition requirements

If you are installing a new feature, ensure that you have the software that is required to support the new feature and that you determine whether there are any prerequisites for this feature and attaching devices. To check for the prerequisites, see IBM Prerequisite website (www-912.ibm.com/e_dir/eServerPrereq.nsf).

The adapter is supported on the following versions of the operating systems:

- AIX
 - AIX Version 7.1, or later.
 - AIX Version 6.1, or later.
- Linux
 - Red Hat Enterprise Linux 6.4, or later.
 - SUSE Linux Enterprise Server 11 Service Pack 3, or later.
 - The latest version of iprutils can be downloaded from IBM Service and Productivity Tools website (<http://www14.software.ibm.com/webapp/set2/sas/f/lopdiags/home.html>).
- IBM i
 - IBM i 7.1 (with TR7), or later.
 - IBM i 6.1 (with 6.1.1-M Machine Code), or later.
- Supported on Firmware level 7.8, or later.

This adapter requires the following drivers:

- AIX: devices.pci.14104A0 device driver package

PCIe3 RAID SAS quad-port 6 Gb LP Adapter (FC EJ0M; CCIN 57B4)

Learn about the specifications and operating system requirements for the feature code (FC) EJ0M adapter.

Overview

The PCIe3 RAID SAS quad-port 6 Gb LP Adapter is a PCI Express (PCIe), generation 3, RAID SAS adapter that has a low-profile and short-form factor. The adapter is used in high-performance and high-density, serial attached SCSI (SAS) applications. It supports the attachment of SAS hard disk drives (HDDs) and solid-state devices (SSDs) by using four mini SAS high-density (HD) x4 connectors that allow the physical links to be used in various narrow and wide-port configurations. The adapter does not have write cache. Figure 25 on page 71 shows the PCIe3 RAID SAS quad-port 6 Gb LP Adapter.

The adapter is a 64 bit, 3.3 V, bootable SAS adapter that provides RAID 0, 5, 6, and 10 capability, and system level mirroring via the operating system. The adapter provides both single and dual RAID controller configurations. Dual controller configurations (dual storage IOA) must run RAID. JBOD (512 byte) functionality is supported only in a single controller configuration based on the operating system. Best performance is achieved when multiple RAID sets are configured and optimized under a pair of adapters in a high availability, multi-initiator RAID configuration (dual storage IOA) which allows for an Active-Active mode of operation.

The adapter supports a maximum of 96 attached disk devices that depends on the drive enclosure attached. A maximum of 48 devices can be solid-state devices (SSDs). Externally attached devices are designed to run at a maximum data rate of 6 Gbps for SAS disk devices. This adapter supports RAID and non-RAID DASD. Specific device attachment support rules apply. This adapter supports the multi-initiator and high availability (dual storage IOA) configurations in AIX, IBM i, and Linux partitions. This adapter enables configuring the SAS drives as dedicated hot-spares with equal or higher capacity.

Important: See the SAS RAID controllers for AIX, SAS RAID controllers for Linux, or SAS RAID controllers for IBM i topics for more information and important considerations for multi-initiator and high availability or dual storage IOA configurations

Figure 25 on page 71 shows the adapter. The connector plug (A) is installed in an empty port and prevents damage to that port whenever a cable for the adjacent port connectors is plugged-in or removed.

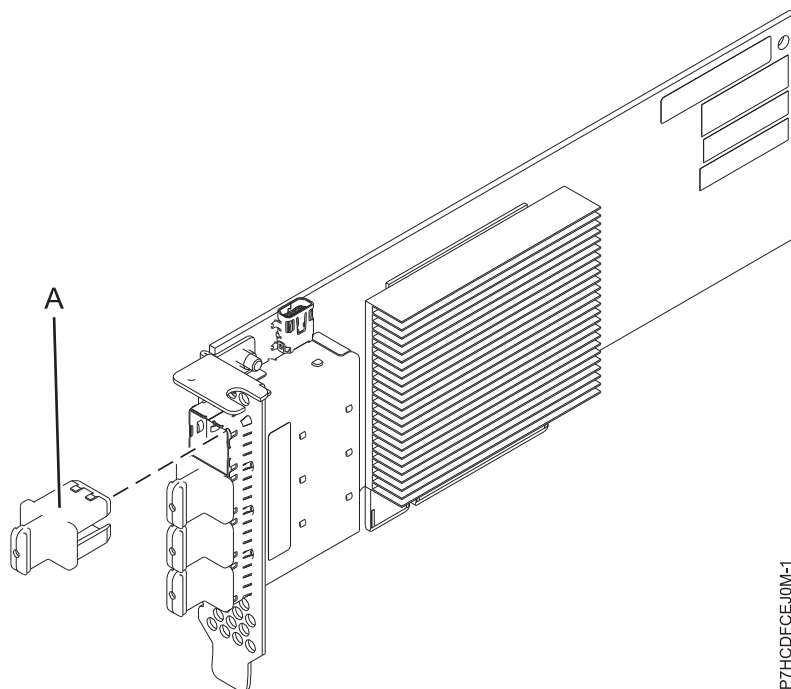

Figure 25. PCIe3 RAID SAS quad-port 6 Gb LP Adapter

Specifications

Item Description

Adapter FRU number

00E7167 (Designed to comply with RoHS requirement)

Connector plug part number

00FW784 (The connector plug is installed in an empty port and prevents damage to that port whenever a cable for the adjacent port connectors is plugged-in or removed.)

I/O bus architecture

PCIe 3.0 but compatible to PCIe 2.0 or PCIe 1.0 slots.

Slot requirement

One available PCIe x8 slot per adapter.

Cables

Specific X, YO, AA, or AT SAS cable features with new narrow HD connectors are used to attach to the other adapter or disk expansion drawers.

SAS device attachment requires specific cables that are provided with the subsystem or device features that are being attached. Special cabling is required for multi-initiator and high availability configurations. See Serial attached SCSI cable planning.

Voltage

3.3 V

Form factor

Short, low-profile but packaged for full-height installations.

Maximum number

For the maximum adapters supported, see the PCI adapter placement topic collection for your system.

Attributes

- Four external mini SAS HD 4x connectors provide attachment of SAS device enclosures
- SAS Serial SCSI Protocol (SSP) and Serial Management Protocol (SMP)
- RAID 0, 5, 6, or 10 with hot-spare capability. System level mirroring through the operating system is also supported. JBOD functionality (512 byte) is supported in a single controller configuration only.

- Concurrent firmware update
- Support for multi-initiator and high availability or single controller configurations

Operating system or partition requirements

If you are installing a new feature, ensure that you have the software that is required to support the new feature and that you determine whether there are any prerequisites for this feature and attaching devices. To check for the prerequisites, see IBM Prerequisite website (www-912.ibm.com/e_dir/eServerPrereq.nsf).

The adapter is supported on the following versions of the operating systems:

- AIX
 - AIX Version 7.1, or later.
 - AIX Version 6.1, or later.
- Linux
 - Red Hat Enterprise Linux 6.4, or later.
 - SUSE Linux Enterprise Server 11 Service Pack 3, or later.
 - The latest version of iprutils can be downloaded from IBM Service and Productivity Tools website (<http://www14.software.ibm.com/webapp/set2/sas/f/lopdiags/home.html>).
- IBM i
 - IBM i 7.1 (with TR7), or later.
 - IBM i 6.1 (with 6.1.1-M Machine Code), or later.
- Supported on Firmware level 7.8, or later.

This adapter requires the following drivers:

- AIX: devices.pci.14104A0 device driver package

PCIe3 4 x8 SAS Port Adapter (FC EJ10; CCIN 57B4)

Learn about the specifications and operating system requirements for the feature code (FC) EJ10 adapter.

Overview

The PCIe3 4 x8 SAS Port Adapter is a PCI Express (PCIe), generation 3, RAID SAS adapter that has a low-profile, short-form factor, but packaged for full height installation. The adapter is used in high-performance and high-density, serial attached SCSI (SAS) applications. It supports the attachment of SAS DVD or SAS tape by using four mini SAS high-density (HD) x4 connectors that allow the physical links to be used in various narrow and wide-port configurations. SAS tape attachment is only supported in a single adapter configuration and cannot be mixed with SAS disk on the same adapter. The adapter does not have write cache. Figure 26 on page 73 shows the PCIe3 4 x8 SAS Port Adapter.

A maximum of four DVD or tape drives can be attached per adapter by using four AE1 cables (FC ECBY). A maximum of eight DVD or tape drives can be attached by using four YE1 cables (ECBZ).

Externally attached devices are designed to run at a maximum data rate of 6 Gbps for SAS tape devices.

Important: See the SAS RAID controllers for AIX, SAS RAID controllers for Linux, or SAS RAID controllers for IBM i topics for more information and important considerations for multi-initiator and high availability or dual storage IOA configurations

Figure 26 on page 73 shows the adapter. The connector plug (A) is installed in an empty port and prevents damage to that port whenever a cable for the adjacent port connectors is plugged-in or removed.

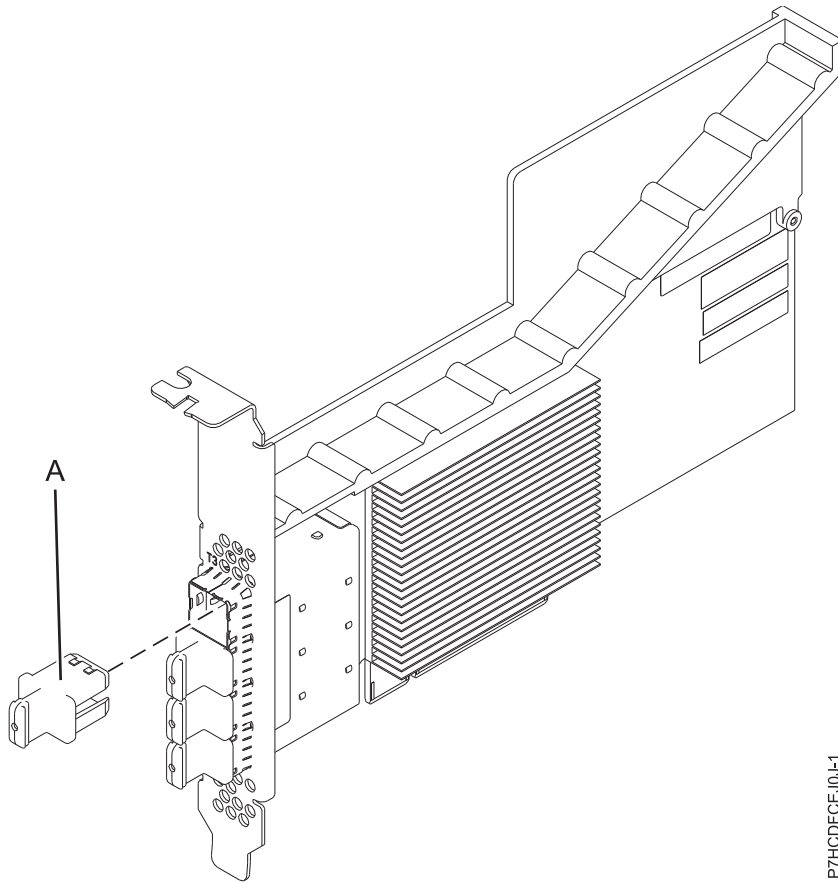

Figure 26. PCIe3 4 x8 SAS Port Adapter

Specifications

Item Description

Adapter FRU number

00E7167 (Designed to comply with RoHS requirement)

Connector plug part number

00FW784 (The connector plug is installed in an empty port and prevents damage to that port whenever a cable for the adjacent port connectors is plugged-in or removed.)

I/O bus architecture

PCIe 3.0 but compatible to PCIe 2.0 or PCIe 1.0 slots.

Slot requirement

One available PCIe x8 slot per adapter.

Cables

Specific AE1 or YE1 SAS cable features with new narrow HD connectors are used to attach the adapter to SAS devices.

SAS device attachment requires specific cables that are provided with the subsystem or device features that are being attached. See Serial attached SCSI cable planning.

Voltage

3.3 V

Form factor

Short, low-profile but packaged for full-height installations.

Maximum number

For the maximum adapters supported, see the PCI adapter placement topic collection for your system.

Attributes

- Four external mini SAS HD 4x connectors provide attachment of SAS devices
- SAS Serial SCSI Protocol (SSP) and Serial Management Protocol (SMP)
- Concurrent firmware update
- Removable media device (DVD and SAS tape) are supported in a single controller configuration only and cannot be combined with disk devices attached to the same adapter. Removable media is not supported in multi-initiator and high availability (dual storage IOA) configurations
- Support for multi-initiator and high availability or single controller configurations

Operating system or partition requirements

If you are installing a new feature, ensure that you have the software that is required to support the new feature and that you determine whether there are any prerequisites for this feature and attaching devices. To check for the prerequisites, see IBM Prerequisite website (www-912.ibm.com/e_dir/eServerPrereq.nsf).

The adapter is supported on the following versions of the operating systems:

- AIX
 - AIX Version 7.1, or later.
 - AIX Version 6.1, or later.
- Linux
 - Red Hat Enterprise Linux 6.4, or later.
 - SUSE Linux Enterprise Server 11 Service Pack 3, or later.
 - The latest version of iprutils can be downloaded from IBM Service and Productivity Tools website (<http://www14.software.ibm.com/webapp/set2/sas/f/lopdiags/home.html>).
- IBM i
 - IBM i 7.1 (with TR7), or later.
 - IBM i 6.1 (with 6.1.1-M Machine Code), or later.
- Supported on Firmware level 7.8, or later.

This adapter requires the following drivers:

- AIX: devices.pci.14104A0 device driver package

PCIe3 LP 4 x8 SAS Port Adapter (FC EJ11; CCIN 57B4)

Learn about the specifications and operating system requirements for the feature code (FC) EJ11 adapter.

Overview

The PCIe3 LP 4 x8 SAS Port Adapter is a PCI Express (PCIe), generation 3, RAID SAS adapter is a low-profile, short-form factor adapter. The adapter is used in high-performance and high-density, serial attached SCSI (SAS) applications. It supports the attachment of SAS DVD or SAS tape by using four mini SAS high-density (HD) x4 connectors that allow the physical links to be used in various narrow and wide-port configurations. SAS tape attachment is only supported in a single adapter configuration and cannot be mixed with SAS disk on the same adapter. The adapter does not have write cache. Figure 27 on page 75 shows the PCIe3 LP 4 x8 SAS Port Adapter.

A maximum of four DVD or tape drives can be attached per adapter by using four AE1 cables (FC ECBY). A maximum of eight DVD or tape drives can be attached by using four YE1 cables (ECBZ).

Externally attached devices are designed to run at a maximum data rate of 6 Gbps for SAS tape devices.

Important: See the SAS RAID controllers for AIX, SAS RAID controllers for Linux, or SAS RAID controllers for IBM i topics for more information and important considerations for multi-initiator and high availability or dual storage IOA configurations

Figure 27 shows the adapter. The connector plug (A) is installed in an empty port and prevents damage to that port whenever a cable for the adjacent port connectors is plugged-in or removed.

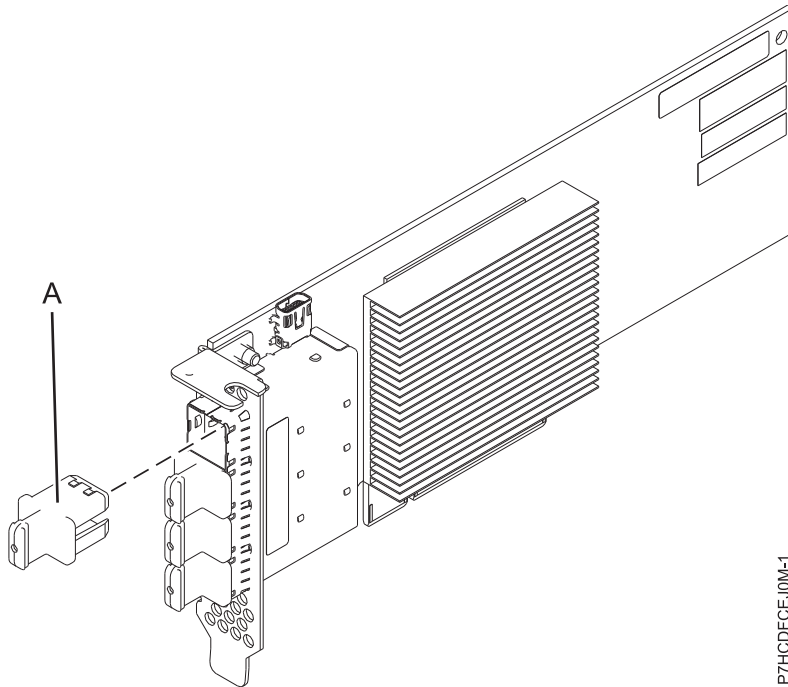

Figure 27. PCIe3 LP 4 x8 SAS Port Adapter

Specifications

Item Description

Adapter FRU number

00E7167 (Designed to comply with RoHS requirement)

Connector plug part number

00FW784 (The connector plug is installed in an empty port and prevents damage to that port whenever a cable for the adjacent port connectors is plugged-in or removed.)

I/O bus architecture

PCIe 3.0 but compatible to PCIe 2.0 or PCIe 1.0 slots.

Slot requirement

One available PCIe x8 slot per adapter.

Cables

Specific AE1 or YE1 SAS cable features with new narrow HD connectors are used to attach the adapter to SAS devices.

SAS device attachment requires specific cables that are provided with the subsystem or device features that are being attached. See Serial attached SCSI cable planning.

Voltage

3.3 V

Form factor

Short, low-profile

Maximum number

For the maximum adapters supported, see the PCI adapter placement topic collection for your system.

Attributes

- Four external mini SAS HD 4x connectors provide attachment of SAS devices
- SAS Serial SCSI Protocol (SSP) and Serial Management Protocol (SMP)
- Concurrent firmware update
- Removable media device (DVD and SAS tape) are supported in a single controller configuration only and cannot be combined with disk devices attached to the same adapter. Removable media is not supported in multi-initiator and high availability (dual storage IOA) configurations
- Support for multi-initiator and high availability or single controller configurations

Operating system or partition requirements

If you are installing a new feature, ensure that you have the software that is required to support the new feature and that you determine whether there are any prerequisites for this feature and attaching devices. To check for the prerequisites, see IBM Prerequisite website (www-912.ibm.com/e_dir/eServerPrereq.nsf).

The adapter is supported on the following versions of the operating systems:

- AIX
 - AIX Version 7.1, or later.
 - AIX Version 6.1, or later.
- Linux
 - Red Hat Enterprise Linux 6.4, or later.
 - SUSE Linux Enterprise Server 11 Service Pack 3, or later.
 - The latest version of iprutils can be downloaded from IBM Service and Productivity Tools website (<http://www14.software.ibm.com/webapp/set2/sas/f/lopdiags/home.html>).
- IBM i
 - IBM i 7.1 (with TR7), or later.
 - IBM i 6.1 (with 6.1.1-M Machine Code), or later.
- Supported on Firmware level 7.8, or later.

This adapter requires the following drivers:

- AIX: devices.pci.14104A0 device driver package

PCIe2 LP 4-port 1GbE Adapter (FC 5260; CCIN 576F)

Learn about the specifications and operating system requirements for the feature code (FC) 5260 adapters.

Overview

FC 5260 and FC 5899 are both the same adapter with different feature codes. FC 5260 is a low-profile adapter and the FC 5899 is a full-height adapter. The names of these two adapters are:

- FC 5260: PCIe2 LP 4-port 1GbE Adapter
- FC 5899: PCIe2 4-port 1GbE Adapter

The PCIe2 LP 4-port 1GbE Adapter is a short, low-profile, generation-2 PCIe adapter. This adapter provides four 1-Gb Ethernet ports that can be configured to run at 1000 megabits per second (Mbps) (or 1 gigabit per second (Gbps)), 100 Mbps, or 10 Mbps. The adapter connects to a network that uses unshielded twisted pair (UTP) cable for distances of up to 100 meters (328.08 feet). The adapter supports AIX Network Installation Management (NIM) boot capability. The adapter conforms to the IEEE 802.3ab 1000Base-T standard. The adapter supports jumbo frames when running at the 1000 Mbps speed.

Each of the Ethernet ports can be connected by using:

- CAT5e (or later) UTP cables for 1000 Mbps network attachment
- CAT5 or CAT3 UTP cables for 100 Mbps or 10 Mbps network attachment

The cables are attached to the copper RJ45 connectors. Each port is independent of one another and supports full-duplex or half-duplex. The half-duplex mode does not support a speed of 1000 Mbps.

The adapter provides the following features:

- Supports interrupt moderation to deliver increased performance while significantly reducing processor utilization
- Supports dual port operation in almost any PCIe slot, except x1
- Supports auto-negotiation, full-duplex only
- Supports integrated media-access control (MAC) and physical layer (PHY)
- Supports Fast EtherChannel (FEC) with the existing software
- Supports gigabit EtherChannel (GEC) with the existing software
- Supports IEEE 802.3ad (Link Aggregation control protocol)
- Supports IEEE 802.1Q VLANs
- Supports IEEE 802.3 z, ab, u, x flow control support
- Supports IEEE 802.1p
- Supports IEEE 802.3ab for TX
- Supports TCP checksum offload transmission control protocol (TCP), user datagram protocol (UDP), Internet Protocol (IP) for IPv4 and IPv6
- Supports TCP segmentation or large send offload
- Supports EEPROM-SPI and single EEPROM
- Supports interrupt levels INTA and MSI
- Hardware certifications FCC B, UL, CE, VCCI, BSMI, CTICK, MIC
- Network Controller (MAC) Intel 82571EB
- Compliant with European Union Directive 2002/95/EC on the Restriction of the Use of Certain Hazardous Substances in Electrical and Electronic Equipment

Specifications

Item Description

Adapter FRU number

74Y4064 (Designed to comply with RoHS requirement)

Wrap plug

10N7405

I/O bus architecture

PCIe2.0 x4

Slot requirement

One PCIe x4 (low-profile) slot.

Cables

4-pair, CAT5e, UTP cables are connected to copper RJ45 connectors.

Voltage

3.3 V

Form factor

Low-profile

Maximum number

For the maximum adapters supported, see the PCI adapter placement topic collection for your system.

Connector information

- Two RJ-45 ports

- Two LED adapter status indicators per port, for link activity and speed

Attributes provided

- PCIe x4, generation-1 or generation-2
- 4-Port machine access code (MAC)
- High performance IPV4/IPV6 checksum offload
- Supports large send and large receive
- Multiple queues
- VIOS

The following figure shows the adapter.

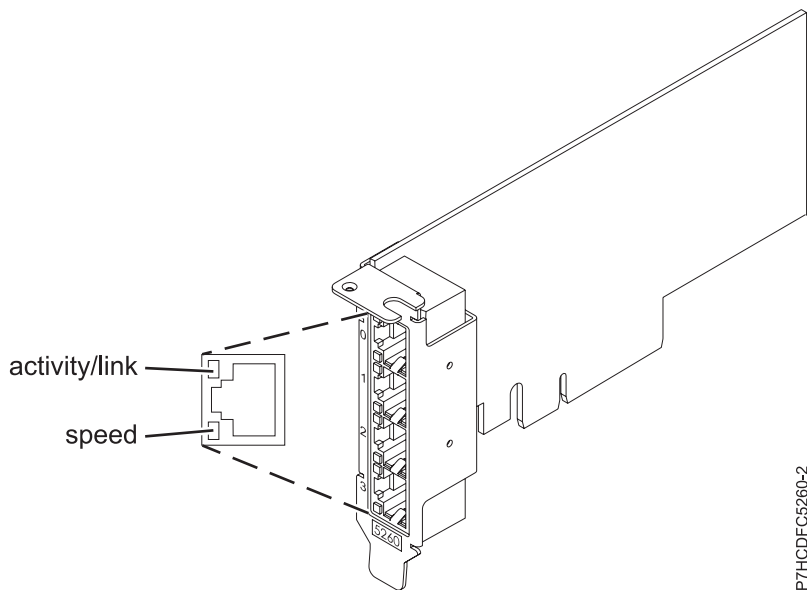

Figure 28. Adapter

Adapter LED states

The LEDs on the adapter provide information about the operation status of the adapter. The LEDs are visible through the mounting bracket. Figure 28 shows the location of the LEDs. Table 23 describes the different LED states and what those states indicate.

Table 23. Adapter LEDs and descriptions

LED	Light	Description
Speed	Yellow	10 Mbps or 100 Mbps
	Green	1000 Mbps or 1 Gbps
Activity/link	Green flashing	Active link or data activity
	Off	No link The absence of a link can indicate a defective cable, defective connector, or a configuration mismatch.

For details about slot priorities and placement rules, see the PCI adapter placement topic collection for your system.

Operating system or partition requirements

This adapter is supported for the following versions of operating systems:

- AIX
 - AIX 7.1, Service Pack 6, or later.
 - AIX 7.1, Service Pack 4, or later.
 - AIX 6.1, Service Pack 8, or later.
 - AIX 6.1, Service Pack 4, or later.
 - AIX 5.3, Service Pack 6, or later.
- Linux
 - Red Hat Enterprise Linux Version 6.2, or later.
 - Red Hat Enterprise Linux Version 5.8, or later.
 - SUSE Linux Enterprise Server 11, Service Pack 2, or later (with update package).
 - See the Linux Alert site for the support details.
- IBM i
 - IBM i 7.1, or later.
 - IBM i 6.1, or later.
- VIOS
 - VIOS support requires VIOS 2.2.1.4, or later.

Related tasks:

[Installing PCI adapters](#)

Related reference:

[IBM Prerequisite website](#)

[Parts information](#)

[PCI adapter placement](#)

“Backplane daughter cards and RAID enablement cards” on page 2

Find links to topics that cover Backplane daughter cards and RAID enablement cards.

PCIe LP 10-Gb FCoE 2-port Adapter (FC 5270; CCIN 2B3B)

Learn about the features, operating system requirements, and installation notes for the feature code (FC) 5270 adapter.

Overview

This PCI Express adapter has two feature codes associated:

- FC 5270: PCIe LP 10-Gb FCoE 2-port Adapter, is the low-profile adapter.
- FC 5708: 10Gb FCoE PCIe Dual Port Adapter, is the full-height adapter.

The PCIe LP 10-Gb FCoE 2-port Adapter is a high-performance, converged network adapter (CNA). The adapter supports data networking and storage networking traffic on a single I/O adapter by using Enhanced Ethernet and Fibre Channel over Ethernet (FCoE). Both FCoE and network interface controller (NIC) functions are available for both ports simultaneously. Using FCoE requires Convergence Enhanced Ethernet (CEE) switches.

The following figure shows the adapter LEDs and connectors.

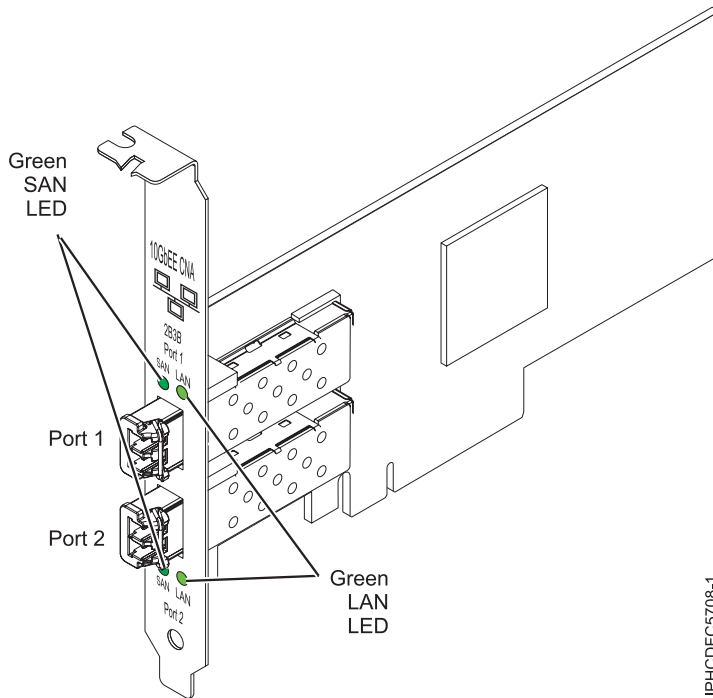

Figure 29. PCIe LP 10-Gb FCoE 2-port Adapter

The LEDs on the adapter provide information about the operation status of the adapter.

Table 24. Adapter LEDs

Green SAN LED	Green LAN LED	Activity
Off	Off	Power off
Slow flashing (unison)	Slow flashing (unison)	Power-on, no link
On	On	Link established, no activity
On	Flashing	Link established, Transmission/Receive (TX/RX) LAN only activity
Flashing	On	Link established, TX/RX SAN only activity
Flashing	Flashing	Link established, TX/RX LAN and SAN activity
Slow flashing (alternating)	Slow flashing (alternating)	Beaconing

For details about slot priorities and placement rules, see the PCI adapter placement topic collection for your system.

Specifications

Item Description

FRU number

46K8088 (Designed to comply with RoHS requirement.)

Wrap plug FRU number

12R9314 (Designed to comply with RoHS requirement.)

I/O bus architecture

PCI Express x8 generation-1 and x4 generation-2

PCI Express (PCIe) Base and Card Electromechanical (CEM) 2.0

Maximum number

For the maximum adapters supported, see the PCI adapter placement topic collection for your system.

Connectors

LC multimode fiber optic

SFP+ (small form-factor pluggable) with SR optics

Voltage

3.3 V and 12-V

Form factor

Short, low-profile with standard-size bracket

Cables

Cables are the responsibility of the customer. Use multimode fiber optic cables with short-wave lasers that adhere to the following specifications:

- OM1
 - Multimode 62.5/125 micron fiber
 - 200 MHz x km bandwidth
 - Maximum cable distance 1 is 33 m (108 ft)
- OM2
 - Multimode 50/125 micron fiber
 - 500 MHz x km bandwidth
 - Maximum cable distance is 82 m (269 ft)
- OM3
 - Multimode 50/125 micron fiber
 - 2000 MHz x km bandwidth
 - Maximum cable distance is 300 m (984 ft)

Operating system or partition requirements

The adapter is supported on the following versions of the operating systems:

- AIX
 - AIX Version 7.1 with Service Pack 3, or later
 - AIX Version 6.1 with the 6100-06 Technology Level, and Service Pack 5, or later
 - AIX Version 5.3 with the 5300-12 Technology Level and Service Pack 4, or later
- Linux
 - Red Hat Enterprise Linux 5.6 for POWER, or later
 - Novel SUSE Linux Enterprise Server Service Pack 4, or later
- IBM i
 - Support of this feature with IBM i requires VIOS 2.2 or later
 - IBM i 7.1, or later
- VIOS
 - VIOS support requires VIOS 2.2.0.12-FP24 SP02, or later

Note: If you are installing a new feature, ensure that you have the software that is required to support the new feature and that you determine whether there are any prerequisites. To check for the prerequisites, see IBM Prerequisite website (www-912.ibm.com/e_dir/eServerPrereq.nsf).

Replacing FCoE adapters by using hot swap

When hot swapping FCoE adapters, be aware that device-related software for the storage devices might have additional devices that must be removed. See specific storage device documentation for information about how to remove these additional devices. The adapter has a unique worldwide port name (WWPN).

When using the Fibre Channel function, check the zoning and LUN assignments to ensure that the Fibre Channel function is operating as expected.

Related tasks:

[Installing PCI adapters](#)

Related reference:

[IBM Prerequisite website](#)

[Parts information](#)

[PCI adapter placement](#)

“Backplane daughter cards and RAID enablement cards” on page 2

Find links to topics that cover Backplane daughter cards and RAID enablement cards.

PCIe LP 4-Port 10/100/1000 Base-TX Ethernet Adapter (FC 5271; CCIN 5717)

Learn about features, requirements, and specifications for the feature code (FC) 5271 adapter.

There are two adapters with the same CCIN. The feature code (FC) 5271 and FC 5717 are both the same adapter. FC 5271 is a low-profile adapter and the FC 5717 is a full-height adapter. The names of these two adapters are:

- FC 5271: PCIe LP 4-Port 10/100/1000 Base-TX Ethernet Adapter
- FC 5717: 4-Port 10/100/1000 Base-TX PCI Express Adapter

The PCIe LP 4-Port 10/100/1000 Base-TX Ethernet Adapter is a PCI Express (PCIe), low-profile, four ported, Gigabit Ethernet adapter that can be configured to run either port at 1000, 100, or 10 Mbps data rate. This adapter interfaces to the system through a PCIe bus and connects to a network using a 4-pair CAT-5 Unshielded Twisted Pair (UTP) cable for distances of up to 100 meters. The adapter conforms to the IEEE 802.3ab 1000Base-T standard. The 5717 also supports jumbo frames when running at the 1000 Mbps speed.

The adapter provides the following features:

- Supports interrupt moderation to deliver increased performance while significantly reducing central processing unit (CPU) utilization
- Allows quad-port operation in x4, x8, x16 slots, and each port operates without interfering with the other
- Each port operates without interfering with the other
- Auto-negotiation, full-duplex (half-duplex available for 10/100)
- Integrated media access control (MAC) and physical layer (PHY)
- Supports Fast EtherChannel (FEC) and Gigabit EtherChannel (GEC) when used with capable switch
- Supports IEEE 802.3ad Link Aggregation control protocol when used with capable switch
- IEEE 802.1Q VLANs, IEEE 802.3 (z, ab, u, x) flow control support, IEEE 802.1p
- TCP checksum offload -- transmission control protocol (TCP), Internet Protocol (IP) for IPv4
- TCP Segmentation Offload (TSO) / Large Send Offload (LSO)
- Bus width x4 lane; operable in x4, x8, or x16 slots
- Bus speed (x4, encoded rate) 10 Gbps unidirectional and 20 Gbps bidirectional
- EEPROM SPI and single EEPROM support
- Interrupt levels INTA and MSI (requires system and software support for MSI)
- IEEE 802.3ab
- Hardware certifications FCC B, UL, CE, VCCI, BSMI, CTICK, MIC

- Four RJ-45 connectors
- LEDs on each port identifying speed and link activity
- Compliant with European Union Directive 2002/95/EC on the Restriction of the Use of Certain Hazardous Substances in Electrical and Electronic Equipment

For details about slot priorities and placement rules, see the PCI adapter placement topic collection for your system.

Adapter specifications

Item Description

FRU number

46Y3512*

*Designed to comply with RoHS requirement

I/O bus architecture

- PCIe V1.0a compliant
- Bus width x4 lane PCIe, operable in x4, x8, x16 slots
- Bus speed (x4, encoded rate) 10 Gbps unidirectional; 20 Gbps bidirectional

Busmaster

Yes

Maximum number

For the maximum adapters supported, see the PCI adapter placement topic collection for your system.

Adapter size

PCIe short form

Connector information

- Four RJ-45 ports
- Two LED adapter status indicators per port, for link activity and speed

Cabling

Customers supply their own cables. For best performance, use cables that meet Cat 5e cabling standards, or later.

Adapter LED states

The LEDs on the adapter provide information about the adapter's operation status. The LEDs are visible through the adapter mounting bracket. 4-Port 10/100/1000 Base-TX PCIe adapter shows the location of the LEDs. Table 25 on page 84 describes the different LED states and what those states indicate.

The following figure shows the adapter:

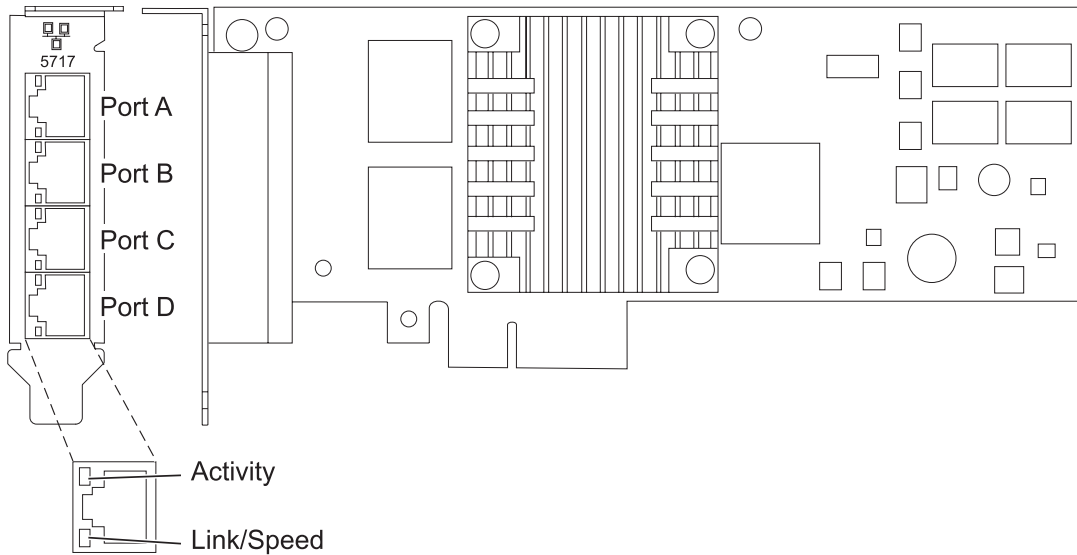

Figure 30. FC 5271 adapter

Table 25. Adapter LEDs and descriptions

LED	Light	Description
Activity/link	Green	Active link
	Off	No link The absence of a link can indicate a defective cable, defective connector, or a configuration mismatch.
	Blinking	Data activity
Speed	Off	10 Mbps
	Green	100 Mbps
	Orange	1000 Mbps

Operating system or partition requirements

The adapter is supported for the following operating systems:

This adapter is supported for the following versions of the operating systems:

- AIX
 - AIX Version 7.1, or later
 - AIX Version 6.1, or later
 - AIX Version 5.3, or later
- Linux
 - Red Hat Enterprise Linux
 - SUSE Linux Enterprise Server
 - See the Linux Alert site for the support details.

If you are using another release of AIX, ensure that the adapter is supported on that release before you install the adapter. Contact service and support for assistance.

If you are installing a new feature, ensure that you have the software required to support the new feature and that you determine if there are any existing prerequisites. To do this, use the IBM Prerequisite

website at http://www-912.ibm.com/e_dir/eServerPrereq.nsf.

Preparing for installation

If you are installing the operating system at this time, install the adapter before you install the operating system. See “Installing the adapter” on page 86 for instructions.

If you are installing only the device driver for this adapter, install the device driver software before you install the adapter. See “Installing the device driver software” for instructions.

If you already have one of these adapters installed and working with your AIX operating system and you are preparing to install additional adapters, the device driver is already installed and you do not need to reinstall the device drive.

Verifying the hardware requirements

The adapter requires the following hardware:

- A wrap plug for the RJ-45 connector, if you are running the total diagnostics package
- CAT5e (or later) UTP cables for 1000 Mbps network attachment
- CAT5 or CAT3 UTP cables for 100 Mbps or 10 Mbps network attachment

Restriction: The cables can be no longer than 100 meters (328.08 feet) (including patch cables) from the adapter to the local switch.

Verifying the software requirements

You can use the adapter on operating systems shown in “Operating system or partition requirements” on page 84.

Gathering tools and documentation

To install the adapter, make sure you have access to the following items:

- The adapter
- The operating system documentation
- The system unit documentation for removing and replacing features
- The PCI adapter placement documentation.
- A flat-blade screwdriver
- The AIX base operating system CD, which includes the device driver, or the AIX device driver CD

Installing the device driver software

This section explains how to install device driver software. The device driver is provided for the AIX 5L operating system on the AIX base operating system CD, which includes the device driver, or the AIX device driver CD.

To install device driver software, do the following steps:

1. Log in to the system unit as root user.
2. Insert the media containing the device driver software (for example, the CD) into the media device.
If your system does not have a CD-ROM drive, refer to your system documentation for performing a Network Installation Management (NIM) installation.
3. Type the following System Management Interface Tool (SMIT) fast path command: `smit devinst`

4. Press Enter. The Install Additional Device Software window highlights the **INPUT device / directory for software** option.
5. Type the name of the input device that you are using, or press F4 to select the input device from a list.
6. Press Enter. The Install Additional Device Software window highlights the **SOFTWARE** to install option.
7. Press F4 to select List.
8. Type / to display the Find window.
9. Type the device package name `devices.pciex.14106803` .
10. Press Enter. The system finds and highlights this device driver software.
11. Press F7 to select the highlighted device driver software.
12. Press Enter. The **INSTALL ADDITIONAL DEVICE SOFTWARE** window displays. The entry fields are automatically updated.
13. Press Enter to accept the information. The **ARE YOU SURE** window displays.
14. Press Enter to accept the information. The **COMMAND STATUS** window displays.
 - The message **RUNNING** is highlighted to indicate that the installation and configuration command is in progress.
 - When **RUNNING** changes to **OK**, scroll to the bottom of the page and locate the installation summary.
 - After a successful installation, **SUCCESS** displays in the Result column of the installation summary at the bottom of the page.
15. Remove the installation media from the drive.
16. Press F10 to exit SMIT.

Verifying the AIX software installation

To verify that the device driver for the adapter is installed, do the following steps:

1. If necessary, log in as root user.
2. Type `lslpp -l devices.pciex.14106803.rte` and press Enter.

If the device driver is installed, the following table is an example of the data that appears.

Fileset	Level	State	Description
Path: /usr/lib/objrepos devices.pciex.14106803.rte	5.x.0.0	COMMITTED	4-Port 10/100/1000 Base-TX PCI Express Software

3. Confirm that the `devices.pciex.14106803.rte` filesets are installed. If no data displays in the window, reinstall the driver.

Installing the adapter

This section explains how to install the adapter. If you are installing the operating system at this time, install the adapter before you install the operating system. If the operating system is already installed and you need to install the device driver for this adapter, install the device driver software before you install the adapter.

Attention: Before installing an adapter, review the precautions in Safety notices and Handling static sensitive devices. Do not remove the adapter from its anti-static package until you are ready to place it in the system unit.

To install the adapter, follow these steps:

1. Determine the PCIe slot in which to place the adapter.
The adapter has an x4 PCIe connector and can be placed in a x4, x8 or x16 slot. See the PCI adapter placement for information about the PCIe slots on your system unit.
2. Install the adapter using the instructions in the system unit service guide.

Verifying the adapter installation

To verify that the system unit recognizes the adapter, type `lsdev -Cs pci` at the command line and press Enter.

A list of PCI devices displays. If the adapter is installed correctly, the status of available for each port indicates that the adapter is installed and ready to use. If a message indicates that any of the ports are defined instead of available, shut down the server and verify that the adapter was installed correctly.

Related tasks:

[🔗 Installing PCI adapters](#)

Related reference:

[🔗 IBM Prerequisite website](#)

[🔗 Parts information](#)

[🔗 PCI adapter placement](#)

“Backplane daughter cards and RAID enablement cards” on page 2

Find links to topics that cover Backplane daughter cards and RAID enablement cards.

PCIe LP 10GbE CX4 1-port Adapter (FC 5272; CCIN 5732)

Learn about the features, operating system requirements, and installation procedures for the feature code (FC) 5272 adapter.

Overview

The PCIe LP 10GbE CX4 1-port Adapter is a low-profile, high performance CX4 copper network interface controller (NIC). The product conforms to the IEEE, 802.3ae 10GBASE-CX specification for Ethernet transmission. 10GBase-CX4 uses the XAUI (10 Gigabit attachment unit interface) specified in 802.3ae, and the 4X connector that is used for InfiniBand technology. The adapter is used to connect servers or switches over short distances of up to 15 meters.

The following figure shows the adapter.

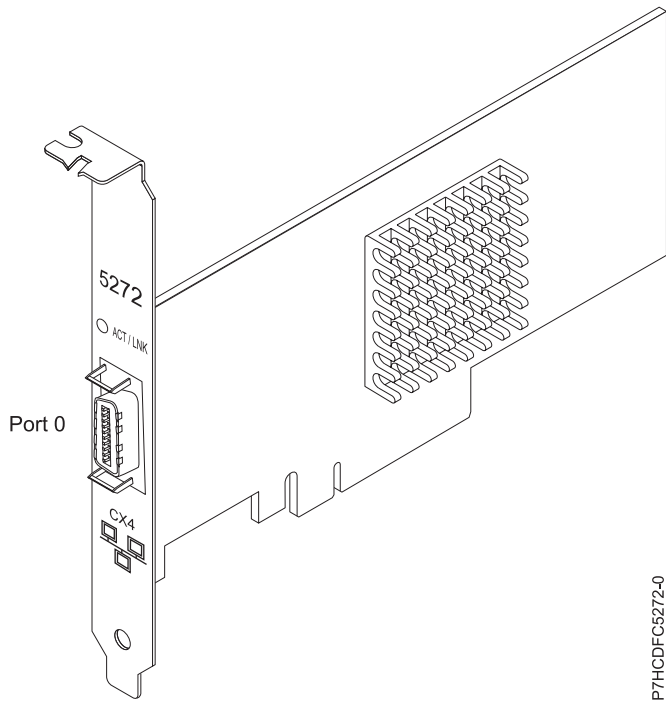

Figure 31. PCIe LP 10GbE CX4 1-port Adapter

The LED on the adapter provides information about the operation status of the adapter.

Table 26. Adapter LED

LED	Light	Description
Activity/Link	Green	Good link, no activity
	Flashing	Transmit activity
	Off	No link*
Board status (visible through ACT/LNK)	Red	Not Initialized**
	Off	Initialized

*The absence of a link can be the result of a defective cable, a defective connector, or a configuration mismatch.
 ** The adapter has not been initialized by the OS. During such time:

- If no cable is connected, the Green LED is ON.
- If cable is connected and the LINK is sensed, the Green LED is OFF.

For details about slot priorities and placement rules, see the PCI adapter placement topic collection for your system.

Specifications

Item Description

FRU number

74Y2226 (designed to comply with RoHS requirement.)

I/O bus architecture

PCIe-V1.1 x8

Busmaster

Yes

Maximum number

For the maximum adapters supported, see the PCI adapter placement topic collection for your system.

Adapter size

PCIe x8, short form

Connector information

10G Ethernet CX4 cable

Cables

Customers supply the cables. The CX4 adapter supports copper CX4 cables. Cables can be ordered through a cable supplier.

Attributes

The adapter provide the following features:

- PCIe 1.1 x8
- MSI-X, MSI and support of traditional pin interrupts
- 10GBASE-CX
- IEEE 802.3ae (10 GbE)
- IEEE 802.1p priority and 802.1Q VLAN tagging
- IEEE 802.3x flow control
- Link aggregation, 802.3ad 802.3 compliance
- IEEE 802.3ad load-balancing and failover
- Ethernet II and 802.3 encapsulated frames
- Multiple MAC addresses per interface
- Jumbo frames up to 9.6 KB
- TCP checksum offload for IPv4 and IPv6
- TCP segmentation offload (TSO) for IPv4 and IPv6
- User datagram protocol (UDP) checksum offload for IPv4 and IPv6
- Receive side scaling and packet steering
- Line rate packet filtering and attack protection
- IETF RDDP and RDMAC iWARP compliance (Linux only)
- APIs: RNIC-PI, kDAPL and Open Fabrics Enterprise Distribution (OFED) 1.4 (Linux only)
- Full iSCSI software and hardware initiator support (Linux only)

Operating system or partition requirements

If you are installing a new feature, ensure that you have the software that is required to support the new feature and that you determine whether there are any prerequisites for this feature and attaching devices. To check for the prerequisites, see IBM Prerequisite website (www-912.ibm.com/e_dir/eServerPrereq.nsf).

This adapter is supported for the following versions of operating systems:

- AIX
 - AIX Version 6.1 with the 6100-03 Technology Level, or later
 - AIX Version 5.3 with the 5300-10 Technology Level, or later
- Linux
 - Red Hat Enterprise Linux Version 5 Update 3, or later
 - SUSE Linux Enterprise Server 11, or later

AIX host bus adapter (HBA) and Ethernet drivers are contained in the following filesets:
devices.ethernet.ct3

```
devices.ethernet.ct3.rte //HBA
devices.ethernet.ct3.cdli //ENT
```

AIX Adapter-specific device attributes are contained in the following file sets:

```
devices.pciex.251430001410a303 (CX4 adapter)
devices.pciex.2514310025140100 (BladeCenter hardware)
```

AIX Adapter-specific device attributes are contained in the following file sets:

```
devices.pciex.251430001410a303 (CX4 adapter)
devices.pciex.2514310025140100 (BladeCenter hardware)
```

Preparing for installation

If you are installing your operating system at this time, install your adapter before you install the operating system. If you are installing only the device driver for this adapter, install your device driver software before you install the adapter. Ensure that your operating system supports this adapter before you install it. See “Operating system or partition requirements” on page 89.

Installing the AIX device driver software

To install device driver software, follow the steps in “Installing the AIX device driver software” on page 224.

Installing the adapter

For general instructions on how to install a PCI adapter, see the Installing PCI adapters topic. Return here to verify the adapter installation.

Verifying the adapter installation

To verify that your system recognizes the PCI adapter, do the following steps:

1. If necessary, log in as root user.
2. At the command line, type: `lsdev -Cs pci`
3. Press Enter.

A list of PCI devices is displayed. If the adapter is installed correctly, the status of available for each port indicates that the adapter is installed and ready to use. If a message indicates that any of the ports are defined instead of available, shut down your server and verify that the adapter was installed correctly.

Related tasks:

[Installing PCI adapters](#)

Related reference:

[IBM Prerequisite website](#)

[Parts information](#)

[PCI adapter placement](#)

“Backplane daughter cards and RAID enablement cards” on page 2

Find links to topics that cover Backplane daughter cards and RAID enablement cards.

PCIe LP 2-Port 1GbE SX Adapter (FC 5274; CCIN 5768)

Learn about features, requirements, and specifications for the feature code (FC) 5274 adapter.

The PCIe LP 2-Port 1GbE SX Adapter provides two 1 Gbps (1000 Base-SX) full-duplex Ethernet LAN connections. The adapter interfaces to the system through a PCIe bus. It is PCIe x4 capable and conforms to the PCIe 1.0a standard. The adapter connects to a network using a standard shortwave multimode optical cable that conforms to the IEEE 802.3z standard. The adapter supports distances of 260 m (853.01 feet) for 62.5 micron Multi Mode Fiber (MMF) and 550 m (1804.46 feet) for 50.0 micron MMF. AIX Network Installation Management (NIM) boot capability is supported with this adapter.

The adapter provides the following features:

- Supports interrupt moderation to deliver increased performance while significantly reducing processor utilization
- Supports dual port operation in almost any PCIe slot, except x1
- Supports auto-negotiation, full-duplex only
- Supports integrated media-access control (MAC) and physical layer (PHY)
- Supports Fast EtherChannel (FEC) with the existing software
- Supports gigabit EtherChannel (GEC) with the existing software
- Supports IEEE 802.3ad (Link Aggregation control protocol)
- Supports IEEE 802.1Q VLANs
- Supports IEEE 802.3 z, ab, u, x flow control support
- Supports IEEE 802.1p
- Supports IEEE 802.3ab for TX
- Supports TCP checksum offload transmission control protocol (TCP), user datagram protocol (UDP), Internet Protocol (IP) for IPv4 and IPv6
- Supports TCP segmentation or large send offload
- Supports EEPROM-SPI and single EEPROM
- Supports interrupt levels INTA and MSI
- Hardware certifications FCC B, UL, CE, VCCI, BSMI, CTICK, MIC
- Network Controller (MAC) Intel 82571EB
- Compliant with European Union Directive 2002/95/EC on the Restriction of the Use of Certain Hazardous Substances in Electrical and Electronic Equipment

Adapter specifications

Item **Description**

FRU number

10N6846*

*Designed to comply with RoHS requirement

I/O bus architecture

- PCI Express V1.0a compliant
- Bus width x4 lane PCI Express, operable in x4, x8, x16 slots
- Bus speed (x4, encoded rate) 10 Gbps unidirectional; 20 Gbps bidirectional

Busmaster

Yes

Maximum number

For the maximum adapters supported, see the PCI adapter placement topic collection for your system.

Adapter size

PCIe short form

Connector information

Two fiber optic ports, LC connector

LED status indicators for link activity and speed

Wrap plug

LC fiber optic, part number 12R9314

Cabling

Optional LC-SC converter cables are available:

- LC-SC 62.5 micron converter cable, part number 12R9322, FC 2459.
- LC-SC 50 micron use converter cable, part number 12R9321, FC 2456.

Adapter LED states

The LEDs on the adapter provide information about the adapter's operation status. The LEDs are visible through the adapter's mounting bracket. Figure 32 shows the location of the LEDs. Table 27 describes the different LED states and what those states indicate. The following figure shows the adapter.

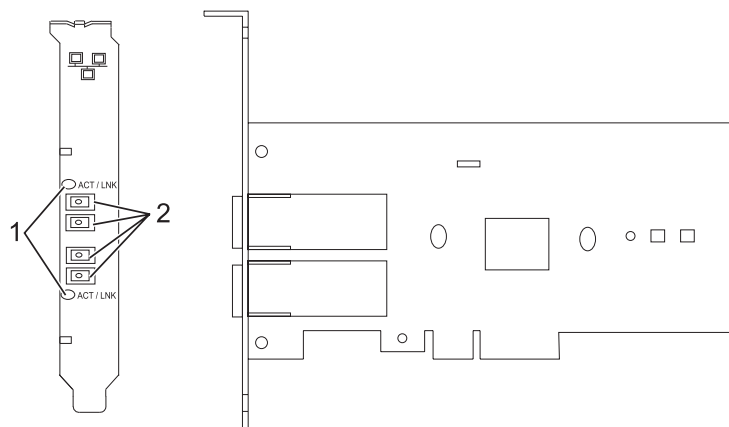

Figure 32. PCIe LP 2-Port 1GbE SX Adapter

- 1 LEDs
- 2 Multimode Fiber LC receptacles

Table 27. Adapter LEDs and descriptions

LED	Description
Off	No link (The absence of a link could indicate a bad cable, bad connector, or a configuration mismatch.)
Green	Good link, no activity
Flashing Green	Good link, data activity

For details about slot priorities and placement rules, see the PCI adapter placement topic collection for your system.

Operating system or partition requirements

If you are installing a new feature, ensure that you have the software that is required to support the new feature and that you determine whether there are any prerequisites for this feature and attaching devices. To check for the prerequisites, see IBM Prerequisite website (www-912.ibm.com/e_dir/eServerPrereq.nsf).

The adapter is supported on the following versions of the operating systems:

- AIX
 - AIX Version 7.1, or later.
 - AIX Version 6.1, or later.
 - AIX Version 5.3, or later.
- Linux

- Red Hat Enterprise Linux 5.6 for POWER, or later.
- Novel SUSE Linux Enterprise Server 11, Service Pack 1, or later.
- IBM i
 - IBM i 7.1, or later.
 - IBM i 6.1, or later.

Preparing for installation

If you are installing the operating system at this time, install the adapter before you install the operating system. See “Installing the adapter” on page 95 for instructions.

If you are installing only the device driver for this adapter, install the device driver software before you install the adapter. See “Installing the device driver software” on page 94 for instructions.

If you already have one of these adapters installed and working with your AIX operating system and you are preparing to install additional adapters, the device driver is already installed and you must not reinstall the device drive.

Verify you hardware requirements

The adapter requires the following hardware:

- A wrap plug for the multimode fiber connector, if you are running the total diagnostics package
- Shortwave (850 nm) 50/62.5 micron multimode fiber network attachment

The following table indicates the allowable cable lengths from the adapter to the gigabit Ethernet switch, including patch cables.

Table 28. Adapter cable information

Cable type	Physical connector type	Maximum range
62.5 m MMF	LC	260 meters (853.01 feet)
50 m MMF	LC	550 meters (1804.46 feet)

Verify your software requirements

The adapter is supported on operating systems shown in Operating system or partition requirements. Ensure that your operating system supports this adapter before you install it. Contact service and support if you need assistance.

Gather tools and documentation

To install the adapter, make sure you have access to the following items:

- The adapter
- The operating system documentation
- The system unit documentation for removing and replacing features
- The PCI adapter placement documentation
- A flat-blade screwdriver
- The AIX base operating system CD, which includes the device driver, or the AIX device driver CD

Installing the device driver software

This section explains how to install device driver software. The device driver is provided for the AIX 5L operating system on the AIX base operating system CD or the AIX device driver CD.

To install device driver software, do the following steps:

1. Log in to the system unit as root user.
2. Insert the media containing the device driver software (for example, the CD) into the media device.
If your system does not have a CD-ROM drive, refer to your system documentation for performing a Network Installation Management (NIM) installation.
3. Type the following System Management Interface Tool (SMIT) fast path command: `smit devinst`
4. Press Enter. The Install Additional Device Software window highlights the **INPUT device / directory for software** option.
5. Type the name of the input device that you are using, or press F4 to select the input device from a list.
6. Press Enter. The Install Additional Device Software window highlights the **SOFTWARE** to install option.
7. Press F4 to select List.
8. Type `/` to display the Find window.
9. Type the device package name `devices.pciex.14103f03`.
10. Press Enter. The system finds and highlights this device driver software.
11. Press F7 to select the highlighted device driver software.
12. Press Enter. The **INSTALL ADDITIONAL DEVICE SOFTWARE** window displays. The entry fields are automatically updated.
13. Press Enter to accept the information. The **ARE YOU SURE** window displays.
14. Press Enter to accept the information. The **COMMAND STATUS** window displays.
 - The message **RUNNING** is highlighted to indicate that the installation and configuration command is in progress.
 - When **RUNNING** changes to **OK**, scroll to the bottom of the page and locate the installation summary.
 - After a successful installation, **SUCCESS** displays in the Result column of the installation summary at the bottom of the page.
15. Remove the installation media from the drive.
16. Press F10 to exit SMIT.

Verify the AIX software installation

To verify that the device driver for the adapter is installed, do the following steps:

1. If necessary, log in as root user.
2. Type `lslpp -l devices.pciex.14103f03.rte` and press Enter.

If the device driver is installed, the following is an example of the data that is displayed.

Fileset	Level	State	Description
Path: /usr/lib/objrepos devices.pciex.14103f03.rte	5.x.0.0	COMMITTED	PCIe LP 2-Port 1GbE SX Adapter

3. Confirm that the `devices.pciex.14103f03.rte` filesets are installed. If no data displays, try reinstalling the driver.

Installing the adapter

This section explains how to install the adapter. If you are installing the operating system at this time, install the adapter before you install the operating system. If the operating system is already installed and you must install the device driver for this adapter, install the device driver software before you install the adapter.

Attention: Before installing an adapter, review the precautions in Safety notices and Handling static sensitive devices. Do not remove the adapter from its anti-static package until you are ready to place it in the system unit.

To install the adapter, follow these steps:

1. Determine the PCIe slot in which to place the adapter.
The adapter has an x4 PCIe connector and can be placed in a x4, x8, or x16 slot. See the PCI adapter placement for information about the PCIe slots on your system unit.
2. Install the adapter by using the instructions in the system unit service guide.

Connecting to an Ethernet network

Refer to your local procedures for information about connecting the adapter to your Ethernet network.

Notes:

- Only one type of network can be attached to the adapter at one time.
- If your switch has an SC receptacle, you need an LC-SC converter cable.
- You must configure an IP network interface to enable the adapter to detect the link and illuminate the link LED.

To connect the adapter to a multimode fiber network, do the following steps:

1. Insert the male fiber LC connector of the fiber cable into the adapter LC connector.
2. Insert the male fiber LC connector of the other end of the cable into the network switch.

Verifying the adapter installation

To verify that the system unit recognizes the adapter, type `lsdev -Cs pci` at the command line and press Enter.

A list of PCI devices displays. If the adapter is installed correctly, the status of available for each port indicates that the adapter is installed and ready to use. If a message indicates that any of the ports are defined instead of available, shut down the server and verify that the adapter was installed correctly.

Related tasks:

[Installing PCI adapters](#)

Related reference:

[IBM Prerequisite website](#)

[Parts information](#)

[PCI adapter placement](#)

“Backplane daughter cards and RAID enablement cards” on page 2

Find links to topics that cover Backplane daughter cards and RAID enablement cards.

PCIe LP 10GbE SR 1-port Adapter (FC 5275; CCIN 5769)

Learn about the features, operating system requirements, and installation procedures for the feature code (FC) 5275 adapter.

Overview

The PCIe LP 10GbE SR 1-port Adapter is a low-profile, high performance fiber network interface controller (NIC). The product conforms to the IEEE, 802.3ae 10GBASE-SR specification for Ethernet transmission.

The following figure shows the adapter LED and network connector. The following figure shows the adapter.

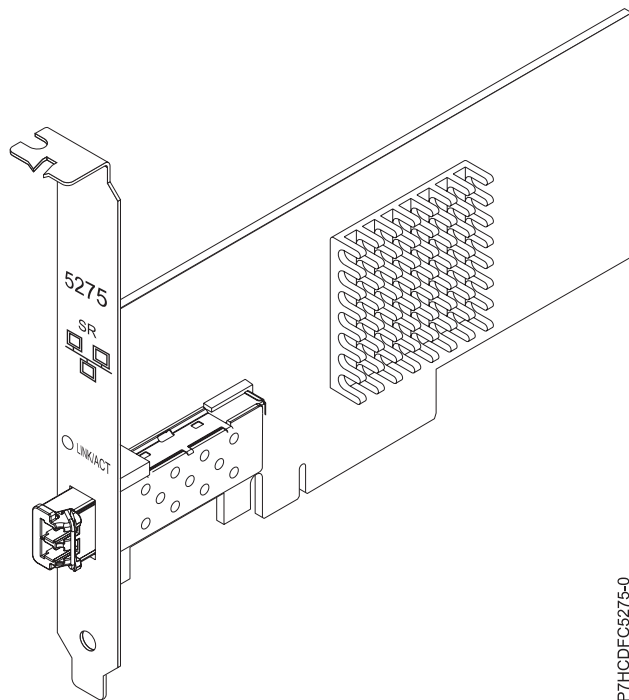

Figure 33. PCIe LP 10GbE SR 1-port Adapter

The LED on the adapter provides information about the operation status of the adapter.

Table 29. Adapter LED

LED	Light	Description
Activity/Link	Green	Good link, no activity
	Flashing Orange	Transmit activity
	Off	No link*
Adapter card status	Red	Not initialized**
	Off	Initialized

*The absence of a link could be the result of a defective cable, a defective connector, or a configuration mismatch.

**The adapter has not been initialized by the operating system. During such time, the following conditions are true:

- If no cable is connected, the Green LED is **ON**.
- If cable is connected and the LINK is sensed, the Green LED is **OFF**.

For details about slot priorities and placement rules, see the PCI adapter placement topic collection for your system.

Specifications

Item Description

FRU number

46K7897 (Designed to comply with RoHS requirement.)

I/O bus architecture

PCIe-V1.1 x8

Busmaster

Yes

Maximum number

For the maximum adapters supported, see the PCI adapter placement topic collection for your system.

Adapter size

PCIe x8, short form

Connector information

LC multimode fiber optic

Wrap plug

LC wrap plug-d, part number 12R9314 (Designed to comply with RoHS requirement.)

Cables

Customers supply the cables. Optional LC-SC 62.5 micron converter cable, part number 12R9322, FC 2459, is available. For 50 micron LC-SC connections, use converter cable part number 12R9321, FC 2456.

Attributes

The adapter provide the following features:

- PCIe 1.1 x8
- MSI-X, MSI and support of traditional pin interrupts
- 10GBASE-SR short-reach optics (850 nm)
- IEEE 802.3ae (10 GbE)
- IEEE 802.1p priority and 802.1Q VLAN tagging
- IEEE 802.3x flow control
- Link aggregation, 802.3ad 802.3 compliance
- IEEE 802.3ad load-balancing and failover
- Ethernet II and 802.3 encapsulated frames
- Multiple MAC addresses per interface
- Jumbo frames up to 9.6 KB
- TCP checksum offload for IPv4 and IPv6
- TCP segmentation offload (TSO) for IPv4 and IPv6
- User datagram protocol (UDP) checksum offload for IPv4 and IPv6
- Receive side scaling and packet steering
- Line rate packet filtering and attack protection
- IETF RDDP and RDMAC iWARP compliance (Linux only)
- RDMA-enabled NIC (RNIC) specifically optimized for cluster computing (Linux only)
- Full iSCSI initiator and target mode stack (Linux only)
- iSCSI Header & Data Digest (CRC) generation & checking (Linux only)
- PDU recovery (Linux only)

Operating system or partition requirements

If you are installing a new feature, ensure that you have the software that is required to support the new feature and that you determine whether there are any prerequisites for this feature and attaching devices. To check for the prerequisites, see IBM Prerequisite website (www-912.ibm.com/e_dir/eServerPrereq.nsf).

This adapter is supported for the following versions of operating systems:

- AIX
 - AIX Version 6.1 with the 6100-03 Technology Level, or later
 - AIX Version 5.3 with the 5300-10 Technology Level, or later
- Linux
 - Red Hat Enterprise Linux Version 5 Update 3, or later
 - SUSE Linux Enterprise Server 11, or later

AIX host bus adapter (HBA) and Ethernet drivers are contained in the following filesets:

```
devices.ethernet.ct3
devices.ethernet.ct3.rte //HBA
devices.ethernet.ct3.cdli //ENT
```

Preparing for installation

If you are installing your operating system at this time, install your adapter before you install the operating system. If you are installing only the device driver for this adapter, install your device driver software before you install the adapter.

If you are running the total diagnostics package you need a wrap plug for the multimode fiber connector used for the adapter. To connect to a network, you need a shortwave (850 nm) 50/62.5 micron multimode fiber network attachment.

The following tables indicates the allowable cable lengths from the adapter to the gigabit Ethernet switch, including patch cables:

Table 30. Cable information

Fiber cable type	Connector type	Minimum modal bandwidth at 850 nm (MHz x km)	Operating range in meters
62.5 μm MMF	LC	160	2 to 26 (6.56 ft to 85.30 ft)
		200	2 to 33 (6.56 ft to 108.26 ft)
50 μm MMF	LC	400	2 to 66 (6.56 ft to 216.53 ft)
		500	2 to 82 (6.56 ft to 269.02 ft)
		2000	2 to 300 (6.56 ft to 984.25 ft)

Ensure that your operating system supports this adapter before you install it. See “Operating system or partition requirements” on page 97.

Installing the AIX device driver software

To install device driver software, follow the steps in “Installing the AIX device driver software” on page 224.

Installing the adapter

For general instructions on how to install a PCI adapter, see the Installing PCI adapters topic. Return here to verify the adapter installation.

Verifying the adapter installation

To verify that your system recognizes the PCI adapter, do the following steps:

1. If necessary, log in as root user.

2. At the command line, type: `lsdev -Cs pci`
3. Press Enter.

A list of PCI devices is displayed. If the adapter is installed correctly, the status of available for each port indicates that the adapter is installed and ready to use. If a message indicates that any of the ports are defined instead of available, shut down your server and verify that the adapter was installed correctly.

Connecting to an Ethernet network

This section explains how to connect the adapter to the multimode fiber network. Refer to your local procedures for information about connecting the adapter to your Ethernet network.

Note: Only one type of network can be attached to the adapter at one time.

To connect the adapter to a multimode fiber network, do the following steps:

1. Insert the male fiber LC connector of the fiber cable into the adapter LC connector.
2. Insert the male fiber LC connector of the other end of the cable into the network switch.

Notes:

- The adapter requires an 850 nm multimode fiber optic cable. See Table 30 on page 98.
- If your switch has an SC receptacle, you need an LC-SC converter cable.
- It is necessary to configure an IP network interface to enable the adapter to detect a link and to illuminate the link LED.

Related tasks:

[🔗 Installing PCI adapters](#)

Related reference:

[🔗 IBM Prerequisite website](#)

[🔗 Parts information](#)

[🔗 PCI adapter placement](#)

“Backplane daughter cards and RAID enablement cards” on page 2

Find links to topics that cover Backplane daughter cards and RAID enablement cards.

PCIe2 LP 2x10GbE SFP+ Copper 2x1GbE UTP Adapter (FC 5279; CCIN 2B52)

Learn about the specifications and operating system requirements for the feature code (FC) 5279 adapters.

Overview

The FC 5279 and FC 5745 are both the same adapter. FC 5745 is a full-height adapter, and the FC 5279 is a low-profile adapter. The names of these two adapters are:

- FC 5745: PCIe2 2x10GbE SFP+ Copper 2x1GbE UTP Adapter
- FC 5279: PCIe2 LP 2x10GbE SFP+ Copper 2x1GbE UTP Adapter

The PCIe2 LP 2x10GbE SFP+ Copper 2x1GbE adapter is a PCI Express (PCIe) generation-2, low-profile, four-ported, Ethernet unified wire adapter with a PCIe 2.0 host bus interface. The adapter is optimized for cloud computing, virtualization, storage, and other data center applications. The four-port adapter provides two 10 Gb Ethernet ports and two 1 Gb Ethernet ports. The two 10 Gb small form-factor pluggable (SFP+) copper transceiver ports are used for connectivity with other servers or switches in the network. Each SFP+ port provides Ethernet connectivity with a nominal data rate of 10 Gbps (gigabits per second), and uses SFP+ copper twinaxial cables up to 5 m (16.4 ft) in length. Each of the RJ45 ports

provides Ethernet connectivity at a data rate of 1 Gbps and are connected with unshielded twisted-pair (UTP) Ethernet cables. The link aggregation and failover features of the adapter are ideal for critical network applications that require redundancy and high availability. Figure 34 shows the FC 5745 adapter.

Note: The SFP+ twinaxial copper cables have connectors that are not the same as the AS/400 5250 connector, the CX4 connector, or the 10 GBASE-T connector.

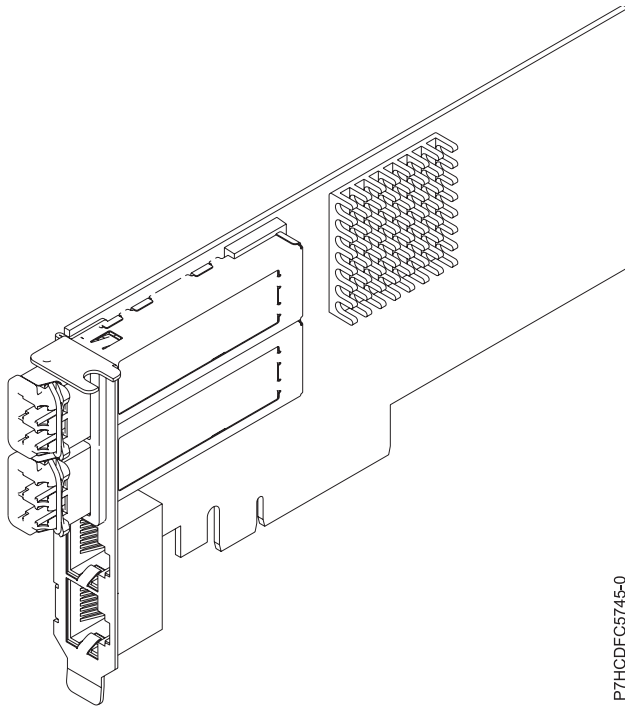

Figure 34. PCIe2 LP 2x10GbE SFP+ Copper 2x1GbE UTP Adapter

For details about slot priorities and placement rules, see the PCI adapter placement topic collection for your system.

Specifications

Item Description

Adapter FRU number

FC 5279: 74Y1986 (Designed to comply with RoHS requirement)

I/O bus architecture

PCIe2 x8

Slot requirement

For the slot priorities, see the PCI adapter placement topic collection for your system.

Cables

See “Cables” on page 101 for details

Voltage

3.3 V

Form factor

Short

Maximum number

For the maximum adapters supported, see the PCI adapter placement topic collection for your system.

Operating system or partition requirements

This adapter is supported for the following versions of the operating system:

- Linux:
 - SUSE Linux Enterprise Server
 - Red Hat Enterprise Linux

Cables

Feature codes 5279 and FC 5745 require the use of compatible SFP+, 10 Gbps, copper, twinaxial, active, Ethernet cables. See Figure 35 for a view of the cable top and cable bottom. These cables are compliant with industry standard specifications SFF-8431 Rev 4.1 and SFF-8472 Rev 10.4, and all applicable IBM requirements.

Note: These cables are EMC Class A compliant.

See Table 31 for details about the feature codes.

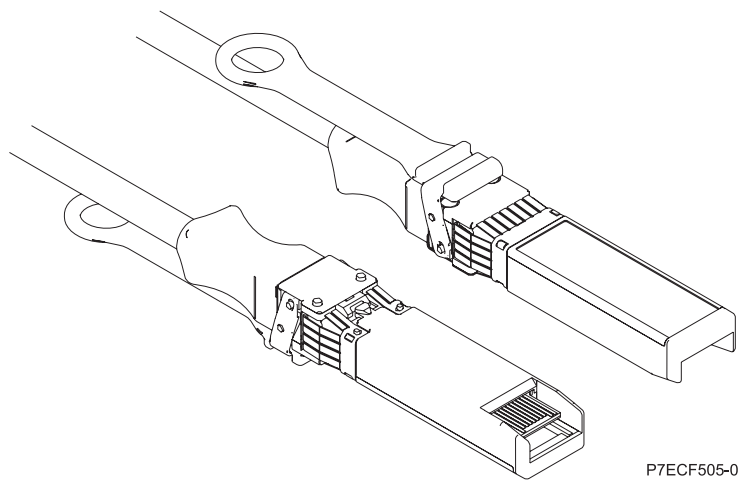

Figure 35. Top and bottom view of the cable

Table 31. Feature code and part number for varying lengths of the cable

Cable length	1 m (3.28 ft)	3 m (9.84 ft)	5 m (16.4 ft)
Feature code	EN01	EN02	EN03
CCIN	EF01	EF02	EF03
Part number	46K6182	46K6183	46K6184

Related tasks:

[Installing PCI adapters](#)

Related reference:

[IBM Prerequisite website](#)

[Parts information](#)

[PCI adapter placement](#)

“Backplane daughter cards and RAID enablement cards” on page 2

Find links to topics that cover Backplane daughter cards and RAID enablement cards.

PCIe2 LP 2x10GbE SR 2x1GbE UTP Adapter (FC 5280; CCIN 2B54)

Learn about the specifications and operating system requirements for the feature code (FC) 5280 adapter.

Overview

The FC 5280 and FC 5744 are both the same adapter. FC 5744 is a full-height adapter, and the FC 5280 is a low-profile adapter. The names of these two adapters are:

- FC 5744: PCIe2 2x10GbE SR 2x1GbE UTP adapter
- FC 5280: PCIe2 LP 2x10GbE SR 2x1GbE UTP adapter

The PCIe2 LP 2x10GbE SR 2x1GbE UTP adapter is a PCI Express generation-2, four-port Ethernet unified wire adapter with a PCI Express 2.0 host bus interface. The adapter is optimized for cloud computing, virtualization, storage, and other data center applications. The four port adapter provides two 10 Gb Ethernet ports and two 1 Gb Ethernet ports. The two 10 Gb small form-factor pluggable (SFP+) single root (SR) transceiver ports are used for connectivity with other servers or switches in the network. Each SFP+ (SR) port provides Ethernet connectivity with a nominal data rate of 10 Gbps (gigabits per second), and uses the SFP+ copper twinaxial cables up to 5 m (16.4 ft) in length. Each of the RJ45 ports provides Ethernet connectivity at a data rate of 1 Gbps. The link aggregation and failover features of the adapter are ideal for critical network applications that require redundancy and high availability. Figure 36 shows the FC 5745 adapter.

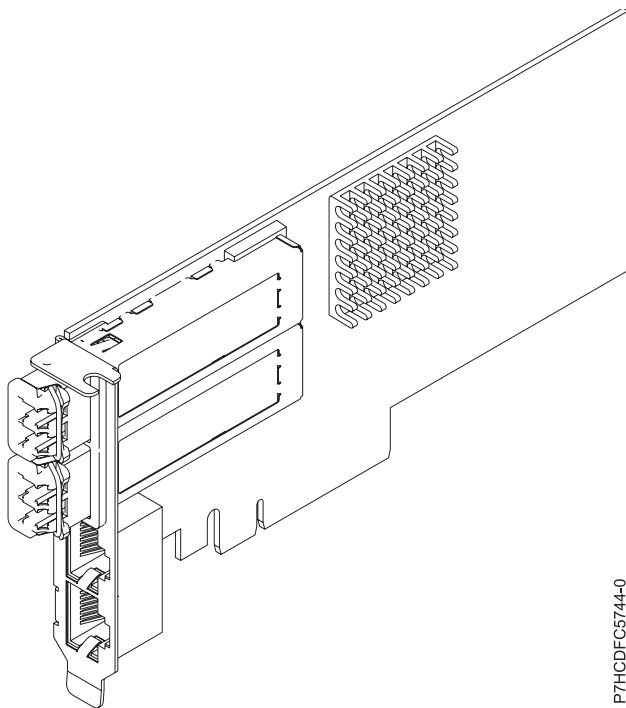

Figure 36. PCIe2 LP 2x10GbE SR 2x1GbE UTP adapter

For details about slot priorities and placement rules, see the PCI adapter placement topic collection for your system.

Specifications

Item	Description
------	-------------

Adapter FRU number	
--------------------	--

FC 5280: 74Y1988	(Designed to comply with RoHS requirement)
------------------	--

FC 5744: 74Y1987 (Designed to comply with RoHS requirement)

I/O bus architecture

PCIe2 x8

Slot requirement

For the slot priorities, see the PCI adapter placement topic collection for your system.

Cables

No cables required.

Voltage

3.3 V

Form factor

Short

Maximum number

For the maximum adapters supported, see the PCI adapter placement topic collection for your system.

Operating system or partition requirements

This adapter is supported for the following versions of the operating system:

- Linux:
 - SUSE Linux Enterprise Server
 - Red Hat Enterprise Linux

Related tasks:

[Installing PCI adapters](#)

Related reference:

[IBM Prerequisite website](#)

[Parts information](#)

[PCI adapter placement](#)

“Backplane daughter cards and RAID enablement cards” on page 2

Find links to topics that cover Backplane daughter cards and RAID enablement cards.

PCIe LP 2-Port 1GbE TX Adapter (FC 5281; CCIN 5767)

Learn about features, requirements, and specifications for the feature code (FC) 5281 adapter.

The PCIe LP 2-Port 1GbE TX Adapter is a low-profile, full duplex, dual port, gigabit Ethernet adapter. This adapter can be configured to run each port at 10, 100, or 1000 Mbps data rates. The adapter connects to a network that uses unshielded twisted pair (UTP) cable for distances of up to 100 meters (328.08 feet). The adapter supports AIX Network Installation Management (NIM) boot capability. The adapter conforms to the IEEE 802.3ab 1000Base-T standard. The adapter supports jumbo frames when running at the 1000 Mbps speed.

The adapter provides the following features:

- Supports interrupt moderation to deliver increased performance while significantly reducing processor utilization
- Supports dual port operation in almost any PCIe slot, except x1
- Supports auto-negotiation, full-duplex only
- Supports integrated media-access control (MAC) and physical layer (PHY)
- Supports Fast EtherChannel (FEC) with the existing software
- Supports gigabit EtherChannel (GEC) with the existing software
- Supports IEEE 802.3ad (Link Aggregation control protocol)
- Supports IEEE 802.1Q VLANs

- Supports IEEE 802.3 z, ab, u, x flow control support
- Supports IEEE 802.1p
- Supports IEEE 802.3ab for TX
- Supports TCP checksum offload transmission control protocol (TCP), user datagram protocol (UDP), Internet Protocol (IP) for IPv4 and IPv6
- Supports TCP segmentation or large send offload
- Supports EEPROM-SPI and single EEPROM
- Supports interrupt levels INTA and MSI
- Hardware certifications FCC B, UL, CE, VCCI, BSMI, CTICK, MIC
- Network Controller (MAC) Intel 82571EB
- Compliant with European Union Directive 2002/95/EC on the Restriction of the Use of Certain Hazardous Substances in Electrical and Electronic Equipment

Adapter specifications

Item Description

FRU number
46K6601*

*Designed to comply with RoHS requirement

I/O bus architecture

- PCI Express V1.0a compliant
- Bus width x4 lane PCI Express, operable in x4, x8, x16 slots
- Bus speed (x4, encoded rate) 10 Gbps unidirectional; 20 Gbps bidirectional

Busmaster

Yes

Maximum number

For the maximum adapters supported, see the PCI adapter placement topic collection for your system.

Adapter size

PCIe short form

Connector information

- Two RJ-45 ports
- Two LED adapter status indicators per port, for link activity and speed

Cabling

Customers supply their own cables. For best performance, use cables that meet CAT5e cabling standards, or later.

Adapter LED states

The LEDs on the adapter provide information about the operation status of the adapter. The LEDs are visible through the mounting bracket. 2-Port 10/100/1000 Base-TX Ethernet PCI Express Adapter shows the location of the LEDs. Table 32 on page 105 describes the different LED states and what those states indicate. The following figure shows the adapter.

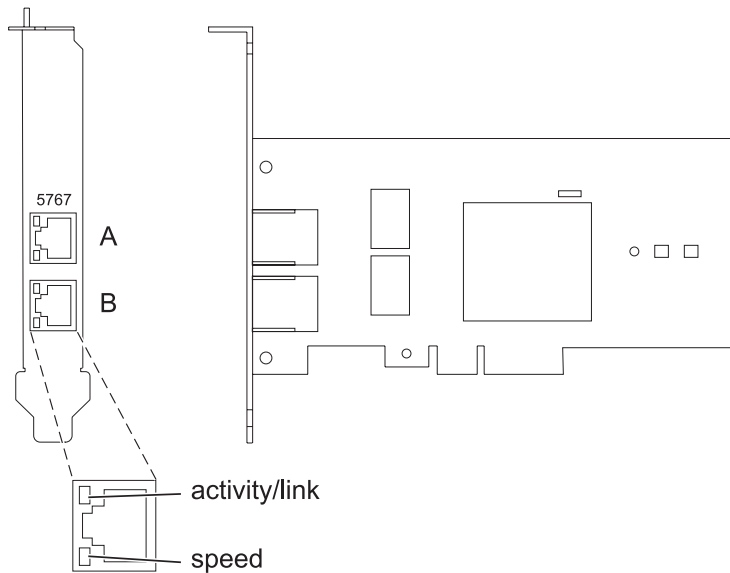

Figure 37. 2-Port 10/100/1000 Base-TX Ethernet PCI Express Adapter

Table 32. Adapter LEDs and descriptions

LED	Light	Description
Activity/link	Green	Active link
	Off	No link The absence of a link can indicate a defective cable, defective connector, or a configuration mismatch.
	Flashing	Data activity
Speed	Off	10 Mbps
	Green	100 Mbps
	Orange	1000 Mbps

For details about slot priorities and placement rules, see the PCI adapter placement topic collection for your system.

Operating system or partition requirements

If you are installing a new feature, ensure that you have the software that is required to support the new feature and that you determine whether there are any prerequisites for this feature and attaching devices. To check for the prerequisites, see IBM Prerequisite website (www-912.ibm.com/e_dir/eServerPrereq.nsf).

The adapter is supported on the following versions of the operating systems:

- AIX
 - AIX Version 7.1, or later.
 - AIX Version 6.1, or later.
 - AIX Version 5.3, or later.
- Linux
 - Red Hat Enterprise Linux 5.6 for POWER, or later.
 - Novel SUSE Linux Enterprise Server 11, Service Pack 1, or later.
- IBM i

- IBM i 7.1, or later.
- IBM i 6.1, or later.

Preparing for installation

If you are installing the operating system at this time, install the adapter before you install the operating system. See “Installing the adapter” on page 107 for instructions.

If you are installing only the device driver for this adapter, install the device driver software before you install the adapter. See “Installing the device driver software” for instructions.

If you already have one of these adapters installed and working with your AIX operating system and you are preparing to install additional adapters, the device driver is already installed and you must not reinstall the device drive.

Verifying the hardware requirements

The adapter requires the following hardware:

- A wrap plug for the RJ-45 connector, if you are running the total diagnostics package.
- CAT5e (or later) UTP cables for 1000 Mbps network attachment.
- CAT5 or CAT3 UTP cables for 100 Mbps or 10 Mbps network attachment.

Restriction: The cables can be no longer than 100 meters (328.08 feet) (including patch cables) from the adapter to the local switch.

Verifying the software requirements

You can use the adapter on operating systems shown in “Operating system or partition requirements” on page 105.

Gathering tools and documentation

To install the adapter, ensure that you have access to the following items:

- The adapter
- The operating system documentation
- The system unit documentation for removing and replacing features
- The PCI adapter placement documentation
- A flat-blade screwdriver
- The AIX base operating system CD, which includes the device driver, or the AIX device driver CD

Installing the device driver software

This section explains how to install device driver software. The device driver is provided for the AIX 5L operating system on the AIX base operating system CD, which includes the device driver, or the AIX device driver CD.

To install device driver software, do the following steps:

1. Log in to the system unit as root user.
2. Insert the media containing the device driver software (for example, the CD) into the media device.
If your system does not have a CD-ROM drive, refer to your system documentation for performing a Network Installation Management (NIM) installation.
3. Type the following System Management Interface Tool (SMIT) fast path command: `smit devinst`

4. Press Enter. The Install Additional Device Software window highlights the **INPUT device / directory for software** option.
5. Type the name of the input device that you are using, or press F4 to select the input device from a list.
6. Press Enter. The Install Additional Device Software window highlights the **SOFTWARE** to install option.
7. Press F4 to select List.
8. Type / to display the Find window.
9. Type the device package name `devices.pciex.14104003`.
10. Press Enter. The system finds and highlights this device driver software.
11. Press F7 to select the highlighted device driver software.
12. Press Enter. The **INSTALL ADDITIONAL DEVICE SOFTWARE** window displays. The entry fields are automatically updated.
13. Press Enter to accept the information. The **ARE YOU SURE** window displays.
14. Press Enter to accept the information. The **COMMAND STATUS** window displays.
 - The message **RUNNING** is highlighted to indicate that the installation and configuration command is in progress.
 - When **RUNNING** changes to **OK**, scroll to the bottom of the page and locate the installation summary.
 - After a successful installation, **SUCCESS** displays in the Result column of the installation summary at the bottom of the page.
15. Remove the installation media from the drive.
16. Press F10 to exit SMIT.

Verifying the AIX software installation

To verify that the device driver for the adapter is installed, do the following steps:

1. If necessary, log in as root user.
2. Type `lspp -l devices.pciex.14104003.rte` and press Enter.

If the device driver is installed, the following table is an example of the data that is shown.

Fileset	Level	State	Description
Path: /usr/lib/objrepos devices.pciex.14104003.rte	5.x.0.0	COMMITTED	PCIe LP 2-Port 1GbE TX Adapter

3. Confirm that the `devices.pciex.14104003.rte` filesets are installed. If no data is shown in the window, reinstall the driver.

Installing the adapter

This section explains how to install the adapter. If you are installing the operating system at this time, install the adapter before you install the operating system. If the operating system is already installed and you must install the device driver for this adapter, install the device driver software before you install the adapter.

Attention: Before installing an adapter, review the precautions in Safety notices and Handling static sensitive devices. Do not remove the adapter from its anti-static package until you are ready to place it in the system unit.

To install the adapter, follow these steps:

1. Determine the PCIe slot in which to place the adapter.

The adapter has an x4 PCIe connector and can be placed in a x4, x8, or x16 slot. See the PCI adapter placement for information about the PCIe slots on your system unit.

2. Install the adapter by using the instructions in the system unit service guide.

Verifying the adapter installation

To verify that the system unit recognizes the adapter, type `lsdev -Cs pci` at the command line and press Enter.

A list of PCI devices displays. If the adapter is installed correctly, the status of available for each port indicates that the adapter is installed and ready to use. If a message indicates that any of the ports are defined instead of available, shut down the server and verify that the adapter was installed correctly.

Related tasks:

[Installing PCI adapters](#)

Related reference:

[IBM Prerequisite website](#)

[Parts information](#)

[PCI adapter placement](#)

“Backplane daughter cards and RAID enablement cards” on page 2

Find links to topics that cover Backplane daughter cards and RAID enablement cards.

PCIe2 LP 2-port 10GbE SR Adapter (FC 5284; CCIN 5287)

Learn about the specifications and operating system requirements for the feature code (FC) 5284 adapters.

Overview

The FC 5284 and FC 5287 are both the same adapter. FC 5284 is a low-profile adapter and the FC 5287 is a full-height adapter.

The PCIe2 LP 2-port 10GbE SR Adapter is a short, low-profile, high-performance, generation-2 PCIe adapter. This adapter provides two 10-Gb Ethernet ports that can be configured to run at 10 gigabits per second (Gbps). Each of the Ethernet ports can be connected by using a little connector (LC) duplex-type connector over a multi-mode fiber (MMF) 850 nm fiber cable up to 300 meters (984.25 feet) in length. The adapter conforms to the IEEE, 802.3ae 10GBASE-SR specification for Ethernet transmission.

For details about slot priorities and placement rules, see the PCI adapter placement topic collection for your system.

Specifications

Item Description

Adapter FRU number

74Y3242 (Designed to comply with RoHS requirement)

I/O bus architecture

PCIe2.0 x8

Slot requirement

One PCIe x8 (low-profile) slot.

Cables

MMF 850 nm fiber cable are connected to LC duplex-type connectors.

Voltage

3.3 V

Form factor

Low-profile

Maximum number

For the maximum adapters supported, see the PCI adapter placement topic collection for your system.

Attributes provided

- PCIe x8 Generation 2
- MSI-X and support of legacy pin interrupts
- 10GBASE-SR short-reach optics
- IEEE 802.3ae (10 GbE)
- IEEE 802.1p priority and 802.1Q VLAN tagging
- IEEE 802.3x flow control
- Link aggregation, 802.3ad 802.3 compliance
- IEEE 802.3ad load-balancing and failover
- Ether II and 802.3 encapsulated frames
- Multiple MAC addresses per interface
- Jumbo frames up to 9.6 Kbytes
- TCP checksum offload for IPv4
- TCP segmentation Offload (TSO) for IPv4
- UDP checksum offload for IPv4
- Receive side scaling and packet steering
- Line rate packet filtering and attack protection

Figure 38 shows the adapter.

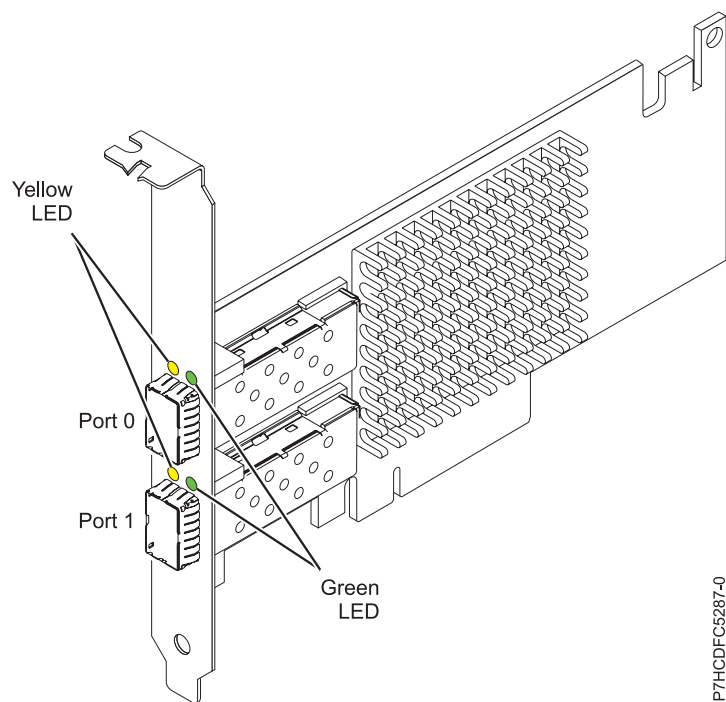

Figure 38. PCIe2 LP 2-port 10GbE SR Adapter

Adapter LED states

The LEDs on the adapter provide information about the adapter's operation status. The LEDs are visible through the adapter's mounting bracket. Figure 38 shows the location of the LEDs. Table 33 on page 110 describes the different LED states and what those states indicate.

Table 33. Adapter LEDs and descriptions

LED	Light	Description
Activity/link	Green	Active link
	Off	No link The absence of a link can indicate a defective cable, defective connector, or a configuration mismatch.
	Flashing	Data activity

Operating system or partition requirements

This adapter is supported for the following versions of operating systems:

- AIX
 - AIX Version 7.1 and Service Pack 3, or later.
 - AIX Version 6.1 with the 6100-06 Technology Level, and Service Pack 3, or later.
 - AIX Version 5.3 with the 5300-12 Technology Level and Service Pack 4, or later.
 - AIX Version 5.3 with the 5300-11 Technology Level and Service Pack 7, or later.
- Linux
 - Red Hat Enterprise Linux.
 - For support details, see the Linux Alert website (www14.software.ibm.com/webapp/set2/sas/f/lopdiags/info/LinuxAlerts.htm)
- IBM i
 - IBM i 7.1 through VIOS.
 - IBM i 6.1 through VIOS.
- VIOS
 - VIOS support requires VIOS 2.2.0.11 with Fix Pack 24 and Service Pack 1, or later.

Related tasks:

[Installing PCI adapters](#)

Related reference:

[IBM Prerequisite website](#)

[Parts information](#)

[PCI adapter placement](#)

“Backplane daughter cards and RAID enablement cards” on page 2

Find links to topics that cover Backplane daughter cards and RAID enablement cards.

PCIe2 LP 2-port 10GbE SFP+ Copper Adapter (FC 5286; CCIN 5288)

Learn about the specifications and operating system requirements for the feature code (FC) 5286 adapter.

Overview

The PCIe2 LP 2-port 10GbE SFP+ copper adapter is the low-profile version of the FC 5288 adapter, which is the full-height adapter. The names of these adapters are:

- FC 5286: PCIe2 LP 2-port 10GbE SFP+ copper adapter
- FC 5288: PCIe2 2-port 10GbE SFP+ copper adapter
-

The PCIe2 LP 2-port 10GbE SFP+ copper adapter is a generation-2, PCIe low-profile adapter that provides two 10 Gb copper small form-factor pluggable transceiver (SFP+) ports for connectivity with other servers or switches in the network. Each port provides Ethernet connectivity with a nominal data rate of 10 gigabits per second (Gbps), and they use SFP+ copper twinaxial cables up to 5 m (16.4 ft) in length.

Note: The SFP+ twinaxial copper cables have connectors that are not the same as the AS/400 5250 connector, the CX4 connector, or the 10 GBASE-T connector.

Each port has a maximum speed of 10 Gbps.

The FC 5286 requires an available slot in FC 5685 (PCIe Riser Card (generation-2)).

For details about slot priorities and placement rules, see the PCI adapter placement topic collection for your system.

Specifications

Item Description

Adapter FRU number

74Y3243 (Designed to comply with RoHS requirement)

I/O bus architecture

PCIe2 x8

Slot requirement

Requires an available slot in FC 5685

Cables

See "Cables" for details

Voltage

3.3 V

Form factor

Short

Maximum number

For the maximum adapters supported, see the PCI adapter placement topic collection for your system.

Operating system or partition requirements

This adapter is supported for the following versions of the operating systems:

- AIX
 - AIX 7.1 with Service Pack 3, or later.
 - AIX 6.1 with the 6100-06 Technology Level, and Service Pack 3 or later.

Cables

Feature code 5286 requires the use of compatible SFP+, 10 Gbps, copper, twinaxial, active, Ethernet cables. See Figure 39 on page 112 for a view of the cable top and cable bottom. These cables are compliant with industry standard specifications SFF-8431 Rev 4.1 and SFF-8472 Rev 10.4, and all applicable IBM i requirements.

Note: These cables are EMC Class A compliant.

The cables contain a unique vital product data (VPD) card that includes the vendor name, part number, EC number, serial number, and date of manufacture. See Table 34 on page 112 for details about the feature codes.

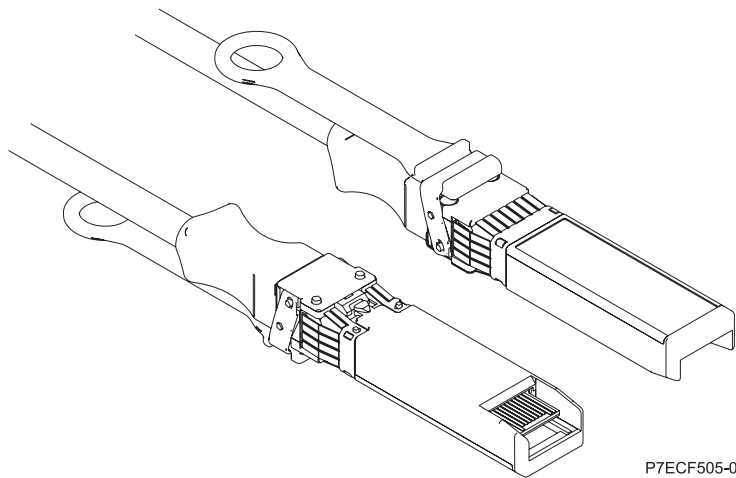

Figure 39. Top and bottom view of the cable

Table 34. Feature code and part number for varying lengths of the cable

Cable length	1 m (3.28 ft)	3 m (9.84 ft)	5 m (16.4 ft)
Feature code	EN01	EN02	EN03
CCIN	EF01	EF02	EF03
Part number	46K6182	46K6183	46K6184

Related tasks:

[Installing PCI adapters](#)

Related reference:

[IBM Prerequisite website](#)

[Parts information](#)

[PCI adapter placement](#)

“Backplane daughter cards and RAID enablement cards” on page 2

Find links to topics that cover Backplane daughter cards and RAID enablement cards.

10-Gb FCoE PCIe Dual Port Adapter (FC 5708; CCIN 2B3B)

Learn about the features, operating system requirements, and installation notes for the feature code (FC) 5708 adapter.

Overview

The 10-Gb FCoE PCIe Dual Port Adapter is a high-performance, converged network adapter (CNA). The adapter supports data networking and storage networking traffic on a single I/O adapter by using Enhanced Ethernet and Fibre Channel over Ethernet (FCoE). Both FCoE and network interface controller (NIC) functions are available for both ports simultaneously. Using FCoE requires Convergence Enhanced Ethernet (CEE) switches.

The following figure shows the adapter LEDs and connectors.

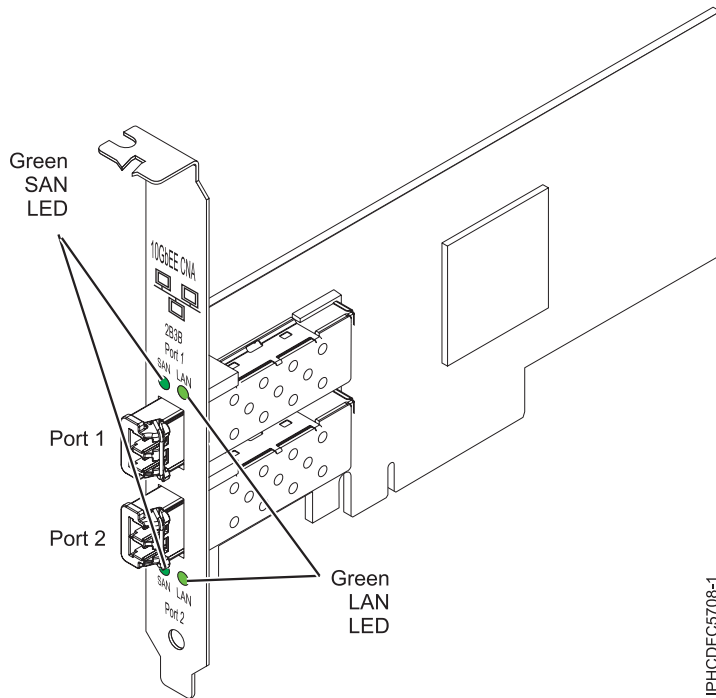

Figure 40. 10-Gb FCoE PCIe Dual Port Adapter

The LEDs on the adapter provide information about the operation status of the adapter.

Table 35. Adapter LEDs

Green SAN LED	Green LAN LED	Activity
Off	Off	Power off
Slow flashing (unison)	Slow flashing (unison)	Power-on, no link
On	On	Link established, no activity
On	Flashing	Link established, Transmission/Receive (TX/RX) LAN only activity
Flashing	On	Link established, TX/RX SAN only activity
Flashing	Flashing	Link established, TX/RX LAN and SAN activity
Slow flashing (alternating)	Slow flashing (alternating)	Beaconing

For details about slot priorities and placement rules, see the PCI adapter placement topic collection for your system.

Specifications

Item Description

FRU number

46K8088 (Designed to comply with RoHS requirement.)

Wrap plug FRU number

12R9314 (Designed to comply with RoHS requirement.)

I/O bus architecture

PCI Express x8 generation-1 and x4 generation-2

PCI Express (PCIe) Base and Card Electromechanical (CEM) 2.0

Maximum number

For the maximum adapters supported, see the PCI adapter placement topic collection for your system.

Connectors

LC multimode fiber optic

SFP+ (small form-factor pluggable) with SR optics

Voltage

3.3 V and 12-V

Form factor

Short, low-profile with standard-size bracket

Cables

Cables are the responsibility of the customer. Use multimode fiber optic cables with short-wave lasers that adhere to the following specifications:

- OM1
 - Multimode 62.5/125 micron fiber
 - 200 MHz x km bandwidth
 - Maximum cable distance 1 is 33 m (108 ft)
- OM2
 - Multimode 50/125 micron fiber
 - 500 MHz x km bandwidth
 - Maximum cable distance is 82 m (269 ft)
- OM3
 - Multimode 50/125 micron fiber
 - 2000 MHz x km bandwidth
 - Maximum cable distance is 300 m (984 ft)

Operating system or partition requirements

The adapter is supported on the following versions of the operating systems:

- AIX
 - AIX Version 7.1 with Service Pack 3, or later
 - AIX Version 6.1 with the 6100-06 Technology Level, and Service Pack 5, or later
 - AIX Version 5.3 with the 5300-12 Technology Level and Service Pack 4, or later
- Linux
 - Red Hat Enterprise Linux 5.6 for POWER, or later
 - Novel SUSE Linux Enterprise Server Service Pack 4, or later
- IBM i
 - Support of this feature with IBM i requires VIOS 2.2 or later
 - IBM i 7.1, or later
- VIOS
 - VIOS support requires VIOS 2.2.0.12-FP24 SP02, or later

Note: If you are installing a new feature, ensure that you have the software that is required to support the new feature and that you determine whether there are any prerequisites. To check for the prerequisites, see IBM Prerequisite website (www-912.ibm.com/e_dir/eServerPrereq.nsf).

Replacing FCoE adapters by using hot swap

When hot swapping FCoE adapters, be aware that device-related software for the storage devices might have additional devices that must be removed. See specific storage device documentation for information about how to remove these additional devices. The adapter has a unique worldwide port name (WWPN).

When using the Fibre Channel function, check the zoning and LUN assignments to ensure that the Fibre Channel function is operating as expected.

Related tasks:

[🔗 Installing PCI adapters](#)

Related reference:

[🔗 IBM Prerequisite website](#)

[🔗 Parts information](#)

[🔗 PCI adapter placement](#)

“Backplane daughter cards and RAID enablement cards” on page 2

Find links to topics that cover Backplane daughter cards and RAID enablement cards.

4-Port 10/100/1000 Base-TX PCI Express Adapter (FC 5717; CCIN 5717)

Learn about features, requirements, and specifications for the feature code (FC) 5717 adapter.

The 4-Port 10/100/1000 Base-TX PCI Express Adapter is a PCI Express (PCIe), full duplex, four ported, Gigabit Ethernet adapter that can be configured to run either port at 1000, 100, or 10 Mbps data rate. This adapter interfaces to the system through a PCIe bus and connects to a network using a 4-pair CAT-5 Unshielded Twisted Pair (UTP) cable for distances of up to 100 meters. The adapter conforms to the IEEE 802.3ab 1000Base-T standard. The 5717 also supports jumbo frames when running at the 1000 Mbps speed.

The adapter provides the following features:

- Supports interrupt moderation to deliver increased performance while significantly reducing central processing unit (CPU) utilization
- Allows quad-port operation in x4, x8, x16 slots, and each port operates without interfering with the other
- Each port operates without interfering with the other
- Auto-negotiation, full-duplex (half-duplex available for 10/100)
- Integrated media access control (MAC) and physical layer (PHY)
- Supports Fast EtherChannel (FEC) and Gigabit EtherChannel (GEC) when used with capable switch
- Supports IEEE 802.3ad Link Aggregation control protocol when used with capable switch
- IEEE 802.1Q VLANs, IEEE 802.3 (z, ab, u, x) flow control support, IEEE 802.1p
- TCP checksum offload -- transmission control protocol (TCP), Internet Protocol (IP) for IPv4
- TCP Segmentation Offload (TSO) / Large Send Offload (LSO)
- Bus width x4 lane; operable in x4, x8, or x16 slots
- Bus speed (x4, encoded rate) 10 Gbps unidirectional and 20 Gbps bidirectional
- EEPROM SPI and single EEPROM support
- Interrupt levels INTA and MSI (requires system and software support for MSI)
- IEEE 802.3ab
- Hardware certifications FCC B, UL, CE, VCCI, BSMI, CTICK, MIC
- Four RJ-45 connectors
- LEDs on each port identifying speed and link activity
- Compliant with European Union Directive 2002/95/EC on the Restriction of the Use of Certain Hazardous Substances in Electrical and Electronic Equipment

For details about slot priorities and placement rules, see the PCI adapter placement topic collection for your system.

Adapter specifications

Item Description

FRU number
46Y3512*

*Designed to comply with RoHS requirement

I/O bus architecture

- PCIe V1.0a compliant
- Bus width x4 lane PCIe, operable in x4, x8, x16 slots
- Bus speed (x4, encoded rate) 10 Gbps unidirectional; 20 Gbps bidirectional

Busmaster

Yes

Maximum number

For the maximum adapters supported, see the PCI adapter placement topic collection for your system.

Adapter size

PCIe short form

Connector information

- Four RJ-45 ports
- Two LED adapter status indicators per port, for link activity and speed

Cabling

Customers supply their own cables. For best performance, use cables that meet Cat 5e cabling standards, or later.

Adapter LED states

The LEDs on the adapter provide information about the adapter's operation status. The LEDs are visible through the adapter's mounting bracket. 4-Port 10/100/1000 Base-TX PCIe Adapter shows the location of the LEDs. Table 36 on page 117 describes the different LED states and what those states indicate.

The following figure shows the adapter:

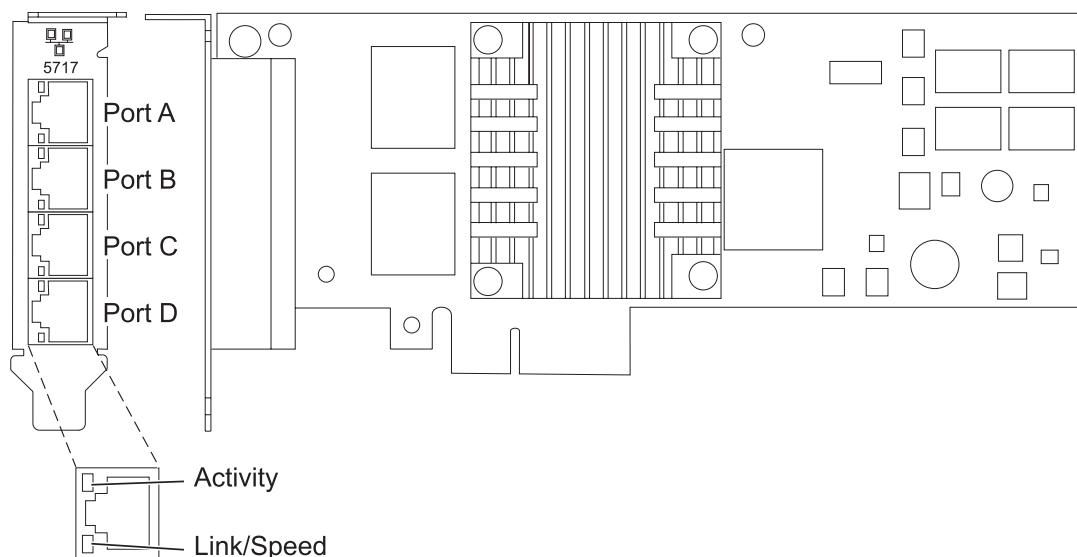

Figure 41. 4-Port 10/100/1000 Base-TX PCIe Adapter

Table 36. Adapter LEDs and descriptions

LED	Light	Description
Activity/link	Green	Active link
	Off	No link The absence of a link can indicate a defective cable, defective connector, or a configuration mismatch.
	Blinking	Data activity
Speed	Off	10 Mbps
	Green	100 Mbps
	Orange	1000 Mbps

Operating system or partition requirements

The adapter is supported for the following operating systems:

This adapter is supported for the following versions of the operating systems:

- AIX
 - AIX Version 7.1, or later
 - AIX Version 6.1, or later
 - AIX Version 5.3, or later
- Linux
 - Red Hat Enterprise Linux
 - SUSE Linux Enterprise Server
 - For support details, see the Linux Alert website (www14.software.ibm.com/webapp/set2/sas/f/lopdiags/info/LinuxAlerts.htm)

If you are using another release of AIX, ensure that the adapter is supported on that release before you install the adapter. Contact service and support for assistance.

If you are installing a new feature, ensure that you have the software that is required to support the new feature and that you determine whether there are any prerequisites for this feature and attaching devices. To check for the prerequisites, see IBM Prerequisite website (www-912.ibm.com/e_dir/eServerPrereq.nsf).

Preparing for installation

If you are installing the operating system at this time, install the adapter before you install the operating system. See “Installing the adapter” on page 119 for instructions.

If you are installing only the device driver for this adapter, install the device driver software before you install the adapter. See “Installing the device driver software” on page 118 for instructions.

If you already have one of these adapters installed and working with your AIX operating system and you are preparing to install additional adapters, the device driver is already installed and you do not need to reinstall the device drive.

Verifying the hardware requirements

The adapter requires the following hardware:

- A wrap plug for the RJ-45 connector, if you are running the total diagnostics package
- CAT5e (or later) UTP cables for 1000 Mbps network attachment

- CAT5 or CAT3 UTP cables for 100 Mbps or 10 Mbps network attachment

Restriction: The cables can be no longer than 100 meters (328.08 feet) (including patch cables) from the adapter to the local switch.

Verifying the software requirements

You can use the adapter on operating systems shown in “Operating system or partition requirements” on page 117.

Gathering tools and documentation

To install the adapter, make sure you have access to the following items:

- The adapter
- The operating system documentation
- The system unit documentation for removing and replacing features
- The PCI adapter placement documentation.
- A flat-blade screwdriver
- The AIX base operating system CD, which includes the device driver, or the AIX device driver CD

Installing the device driver software

This section explains how to install device driver software. The device driver is provided for the AIX 5L operating system on the AIX base operating system CD, which includes the device driver, or the AIX device driver CD.

To install device driver software, do the following steps:

1. Log in to the system unit as root user.
2. Insert the media containing the device driver software (for example, the CD) into the media device.
If your system does not have a CD-ROM drive, refer to your system documentation for performing a Network Installation Management (NIM) installation.
3. Type the following System Management Interface Tool (SMIT) fast path command: `smit devinst`
4. Press Enter. The Install Additional Device Software window highlights the **INPUT device / directory for software** option.
5. Type the name of the input device that you are using, or press F4 to select the input device from a list.
6. Press Enter. The Install Additional Device Software window highlights the SOFTWARE to install option.
7. Press F4 to select List.
8. Type / to display the Find window.
9. Type the device package name `devices.pciex.14106803` .
10. Press Enter. The system finds and highlights this device driver software.
11. Press F7 to select the highlighted device driver software.
12. Press Enter. The INSTALL ADDITIONAL DEVICE SOFTWARE window displays. The entry fields are automatically updated.
13. Press Enter to accept the information. The ARE YOU SURE window displays.
14. Press Enter to accept the information. The COMMAND STATUS window displays.
 - The message RUNNING is highlighted to indicate that the installation and configuration command is in progress.

- When RUNNING changes to OK, scroll to the bottom of the page and locate the installation summary.
 - After a successful installation, SUCCESS displays in the Result column of the installation summary at the bottom of the page.
15. Remove the installation media from the drive.
 16. Press F10 to exit SMIT.

Verifying the AIX software installation

To verify that the device driver for the adapter is installed, do the following steps:

1. If necessary, log in as root user.
2. Type `lslpp -l devices.pciex.14106803.rte` and press Enter.

If the device driver is installed, the following table is an example of the data that appears.

Fileset	Level	State	Description
Path: /usr/lib/objrepos devices.pciex.14106803.rte	5.x.0.0	COMMITTED	4-Port 10/100/1000 Base-TX PCI Express Software

3. Confirm that the `devices.pciex.14106803.rte` filesets are installed. If no data displays in the window, reinstall the driver.

Installing the adapter

This section explains how to install the adapter. If you are installing the operating system at this time, install the adapter before you install the operating system. If the operating system is already installed and you need to install the device driver for this adapter, install the device driver software before you install the adapter.

Attention: Before installing an adapter, review the precautions in Safety notices and Handling static sensitive devices. Do not remove the adapter from its anti-static package until you are ready to place it in the system unit.

To install the adapter, follow these steps:

1. Determine the PCIe slot in which to place the adapter.
The adapter has an x4 PCIe connector and can be placed in a x4, x8 or x16 slot. See the PCI adapter placement for information about the PCIe slots on your system unit.
2. Install the adapter using the instructions in the system unit service guide.

Verifying the adapter installation

To verify that the system unit recognizes the adapter, type `lsdev -Cs pci` at the command line and press Enter.

A list of PCI devices displays. If the adapter is installed correctly, the status of available for each port indicates that the adapter is installed and ready to use. If a message indicates that any of the ports are defined instead of available, shut down the server and verify that the adapter was installed correctly.

Related tasks:

 Installing PCI adapters

Related reference:

 IBM Prerequisite website

➔ Parts information

➔ PCI adapter placement

“Backplane daughter cards and RAID enablement cards” on page 2

Find links to topics that cover Backplane daughter cards and RAID enablement cards.

10 Gigabit Ethernet-CX4 PCI Express Adapter (FC 5732; CCIN 5732)

Learn about the features, operating system requirements, and installation procedures for the feature code (FC) 5732 adapter.

Overview

The 10 Gigabit Ethernet-CX4 PCI Express (PCIe) Adapter is a low-profile, high performance CX4 copper network interface controller (NIC). The product conforms to the IEEE, 802.3ae 10GBASE-CX specification for Ethernet transmission. 10GBase-CX4 uses the XAU1 (10 Gigabit attachment unit interface) specified in 802.3ae, and the 4X connector that is used for InfiniBand technology. The adapter is used to connect servers or switches over short distances of up to 15 meters.

The following figure shows the adapter.

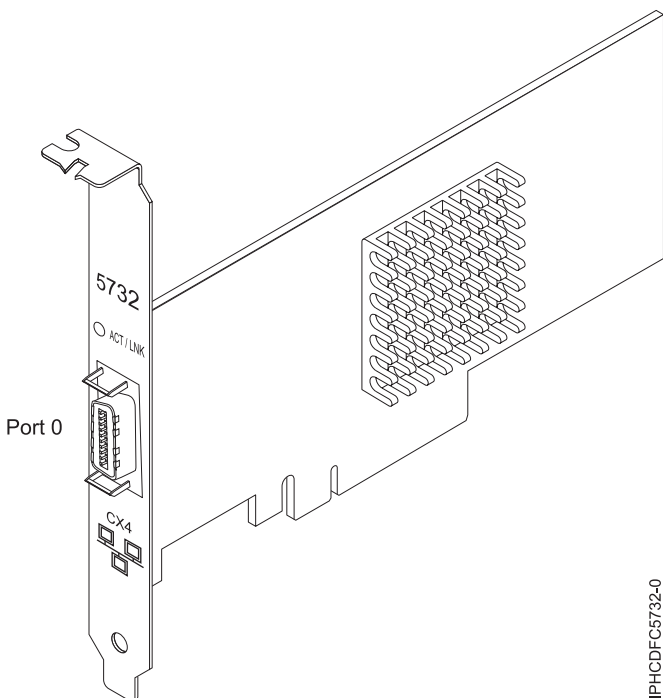

Figure 42. 10 Gigabit Ethernet-CX4 PCI Express (PCIe) Adapter

The LED on the adapter provides information about the operation status of the adapter.

Table 37. Adapter LED

LED	Light	Description
Activity/Link	Green	Good link, no activity
	Flashing	Transmit activity
	Off	No link*

Table 37. Adapter LED (continued)

LED	Light	Description
Board status (visible through ACT/LNK)	Red	Not Initialized**
	Off	Initialized
<p>*The absence of a link can be the result of a defective cable, a defective connector, or a configuration mismatch.</p> <p>** The adapter has not been initialized by the OS. During such time:</p> <ul style="list-style-type: none"> • If no cable is connected, the Green LED is ON. • If cable is connected and the LINK is sensed, the Green LED is OFF. 		

For details about slot priorities and placement rules, see the PCI adapter placement topic collection for your system.

Specifications

Item Description

FRU number

46K7899 (designed to comply with RoHS requirement.)

I/O bus architecture

PCIe-V1.1 x8

Busmaster

Yes

Maximum number

For the maximum adapters supported, see the PCI adapter placement topic collection for your system.

Adapter size

PCIe x8, short form

Connector information

10G Ethernet CX4 cable

Cables

Customers supply the cables. The CX4 adapter supports copper CX4 cables. Cables can be ordered through a cable supplier.

Attributes

The adapter provide the following features:

- PCIe 1.1 x8
- MSI-X, MSI and support of traditional pin interrupts
- 10GBASE-CX
- IEEE 802.3ae (10 GbE)
- IEEE 802.1p priority and 802.1Q VLAN tagging
- IEEE 802.3x flow control
- Link aggregation, 802.3ad 802.3 compliance
- IEEE 802.3ad load-balancing and failover
- Ethernet II and 802.3 encapsulated frames
- Multiple MAC addresses per interface
- Jumbo frames up to 9.6 KB
- TCP checksum offload for IPv4 and IPv6
- TCP segmentation offload (TSO) for IPv4 and IPv6
- User datagram protocol (UDP) checksum offload for IPv4 and IPv6
- Receive side scaling and packet steering

- Line rate packet filtering and attack protection
- IETF RDDL and RDMAC iWARP compliance (Linux only)
- APIs: RNIC-PI, kDAPL and Open Fabrics Enterprise Distribution (OFED) 1.4 (Linux only)
- Full iSCSI software and hardware initiator support (Linux only)

Operating system or partition requirements

If you are installing a new feature, ensure that you have the software that is required to support the new feature and that you determine whether there are any prerequisites for this feature and attaching devices. To check for the prerequisites, see IBM Prerequisite website (www-912.ibm.com/e_dir/eServerPrereq.nsf).

This adapter is supported for the following versions of operating systems:

- AIX
 - AIX Version 6.1 with the 6100-03 Technology Level, or later
 - AIX Version 5.3 with the 5300-10 Technology Level, or later
- Linux
 - Red Hat Enterprise Linux Version 5 Update 3, or later
 - SUSE Linux Enterprise Server 11, or later

AIX host bus adapter (HBA) and Ethernet drivers are contained in the following filesets:

```
devices.ethernet.ct3
devices.ethernet.ct3.rte //HBA
devices.ethernet.ct3.cdli //ENT
```

AIX Adapter-specific device attributes are contained in the following file sets:

```
devices.pciex.251430001410a303 (CX4 adapter)
devices.pciex.2514310025140100 (BladeCenter hardware)
```

AIX Adapter-specific device attributes are contained in the following file sets:

```
devices.pciex.251430001410a303 (CX4 adapter)
devices.pciex.2514310025140100 (BladeCenter hardware)
```

Preparing for installation

If you are installing your operating system at this time, install your adapter before you install the operating system. If you are installing only the device driver for this adapter, install your device driver software before you install the adapter. Ensure that your operating system supports this adapter before you install it. See “Operating system or partition requirements.”

Installing the AIX device driver software

To install device driver software, follow the steps in “Installing the AIX device driver software” on page 224.

Installing the adapter

For general instructions on how to install a PCI adapter, see the Installing PCI adapters topic. Return here to verify the adapter installation.

Verifying the adapter installation

To verify that your system recognizes the PCI adapter, do the following steps:

1. If necessary, log in as root user.

2. At the command line, type: `lsdev -Cs pci`
3. Press Enter.

A list of PCI devices is displayed. If the adapter is installed correctly, the status of available for each port indicates that the adapter is installed and ready to use. If a message indicates that any of the ports are defined instead of available, shut down your server and verify that the adapter was installed correctly.

Related tasks:

“Installing the AIX device driver software” on page 224

Learn how to install the AIX device driver software for a PCI adapter.

“Verifying the AIX device driver software” on page 225

Learn how to verify the AIX device driver is installed for a PCI adapter.

[🔗 Installing PCI adapters](#)

Related reference:

[🔗 IBM Prerequisite website](#)

[🔗 Parts information](#)

[🔗 PCI adapter placement](#)

“Backplane daughter cards and RAID enablement cards” on page 2

Find links to topics that cover Backplane daughter cards and RAID enablement cards.

2-Port 10/100/1000 Base-TX Ethernet PCI Express Adapter (FC 5767; CCIN 5767)

Learn about features, requirements, and specifications for the feature code (FC) 5767 adapter.

The 2-Port 10/100/1000 Base-TX Ethernet PCI Express Adapter is a full duplex, dual port, gigabit Ethernet adapter. This adapter can be configured to run each port at 10, 100, or 1000 Mbps data rates. The adapter connects to a network that uses unshielded twisted pair (UTP) cable for distances of up to 100 meters (328.08 feet). The adapter supports AIX Network Installation Management (NIM) boot capability. The adapter conforms to the IEEE 802.3ab 1000Base-T standard. The adapter supports jumbo frames when running at the 1000 Mbps speed.

The adapter provides the following features:

- Supports interrupt moderation to deliver increased performance while significantly reducing processor utilization
- Supports dual port operation in almost any PCIe slot, except x1
- Supports auto-negotiation, full-duplex only
- Supports integrated media-access control (MAC) and physical layer (PHY)
- Supports Fast EtherChannel (FEC) with the existing software
- Supports gigabit EtherChannel (GEC) with the existing software
- Supports IEEE 802.3ad (Link Aggregation control protocol)
- Supports IEEE 802.1Q VLANs
- Supports IEEE 802.3 z, ab, u, x flow control support
- Supports IEEE 802.1p
- Supports IEEE 802.3ab for TX
- Supports TCP checksum offload transmission control protocol (TCP), user datagram protocol (UDP), Internet Protocol (IP) for IPv4 and IPv6
- Supports TCP segmentation or large send offload
- Supports EEPROM-SPI and single EEPROM
- Supports interrupt levels INTA and MSI

- Hardware certifications FCC B, UL, CE, VCCI, BSMI, CTICK, MIC
- Network Controller (MAC) Intel 82571EB
- Compliant with European Union Directive 2002/95/EC on the Restriction of the Use of Certain Hazardous Substances in Electrical and Electronic Equipment

Adapter specifications

Item Description

FRU number
46K6601*

*Designed to comply with RoHS requirement

I/O bus architecture

- PCI Express V1.0a compliant
- Bus width x4 lane PCI Express, operable in x4, x8, x16 slots
- Bus speed (x4, encoded rate) 10 Gbps unidirectional; 20 Gbps bidirectional

Busmaster

Yes

Maximum number

For the maximum adapters supported, see the PCI adapter placement topic collection for your system.

Adapter size

PCIe short form

Connector information

- Two RJ-45 ports
- Two LED adapter status indicators per port, for link activity and speed

Cabling

Customers supply their own cables. For best performance, use cables that meet CAT5e cabling standards, or later.

Adapter LED states

The LEDs on the adapter provide information about the operation status of the adapter. The LEDs are visible through the mounting bracket. 2-Port 10/100/1000 Base-TX Ethernet PCI Express Adapter shows the location of the LEDs. Table 38 on page 125 describes the different LED states and what those states indicate. The following figure shows the adapter.

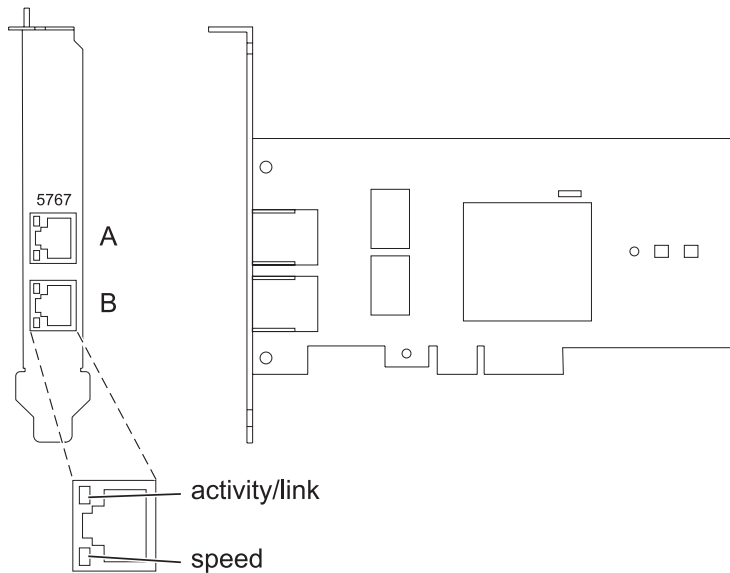

Figure 43. 2-Port 10/100/1000 Base-TX Ethernet PCI Express Adapter

Table 38. Adapter LEDs and descriptions

LED	Light	Description
Activity/link	Green	Active link
	Off	No link The absence of a link can indicate a defective cable, defective connector, or a configuration mismatch.
	Flashing	Data activity
Speed	Off	10 Mbps
	Green	100 Mbps
	Orange	1000 Mbps

For details about slot priorities and placement rules, see the PCI adapter placement topic collection for your system.

Operating system or partition requirements

If you are installing a new feature, ensure that you have the software that is required to support the new feature and that you determine whether there are any prerequisites for this feature and attaching devices. To check for the prerequisites, see IBM Prerequisite website (www-912.ibm.com/e_dir/eServerPrereq.nsf).

The adapter is supported on the following versions of the operating systems:

- AIX
 - AIX Version 7.1, or later.
 - AIX Version 6.1, or later.
 - AIX Version 5.3, or later.
- Linux
 - Red Hat Enterprise Linux 5.6 for POWER, or later.
 - Novel SUSE Linux Enterprise Server 11, Service Pack 1, or later.
- IBM i

- IBM i 7.1, or later.
- IBM i 6.1, or later.

Preparing for installation

If you are installing the operating system at this time, install the adapter before you install the operating system. See “Installing the adapter” on page 127 for instructions.

If you are installing only the device driver for this adapter, install the device driver software before you install the adapter. See “Installing the device driver software” for instructions.

If you already have one of these adapters installed and working with your AIX operating system and you are preparing to install additional adapters, the device driver is already installed and you must not reinstall the device drive.

Verifying the hardware requirements

The adapter requires the following hardware:

- A wrap plug for the RJ-45 connector, if you are running the total diagnostics package.
- CAT5e (or later) UTP cables for 1000 Mbps network attachment.
- CAT5 or CAT3 UTP cables for 100 Mbps or 10 Mbps network attachment.

Restriction: The cables can be no longer than 100 meters (328.08 feet) (including patch cables) from the adapter to the local switch.

Verifying the software requirements

You can use the adapter on operating systems shown in “Operating system or partition requirements” on page 125.

Gathering tools and documentation

To install the adapter, ensure that you have access to the following items:

- The adapter
- The operating system documentation
- The system unit documentation for removing and replacing features
- The PCI adapter placement documentation
- A flat-blade screwdriver
- The AIX base operating system CD, which includes the device driver, or the AIX device driver CD

Installing the device driver software

This section explains how to install device driver software. The device driver is provided for the AIX 5L operating system on the AIX base operating system CD, which includes the device driver, or the AIX device driver CD.

To install device driver software, do the following steps:

1. Log in to the system unit as root user.
2. Insert the media containing the device driver software (for example, the CD) into the media device.
If your system does not have a CD-ROM drive, refer to your system documentation for performing a Network Installation Management (NIM) installation.
3. Type the following System Management Interface Tool (SMIT) fast path command: `smit devinst`

4. Press Enter. The Install Additional Device Software window highlights the **INPUT device / directory for software** option.
5. Type the name of the input device that you are using, or press F4 to select the input device from a list.
6. Press Enter. The Install Additional Device Software window highlights the **SOFTWARE** to install option.
7. Press F4 to select List.
8. Type / to display the Find window.
9. Type the device package name `devices.pciex.14104003`.
10. Press Enter. The system finds and highlights this device driver software.
11. Press F7 to select the highlighted device driver software.
12. Press Enter. The **INSTALL ADDITIONAL DEVICE SOFTWARE** window displays. The entry fields are automatically updated.
13. Press Enter to accept the information. The **ARE YOU SURE** window displays.
14. Press Enter to accept the information. The **COMMAND STATUS** window displays.
 - The message **RUNNING** is highlighted to indicate that the installation and configuration command is in progress.
 - When **RUNNING** changes to **OK**, scroll to the bottom of the page and locate the installation summary.
 - After a successful installation, **SUCCESS** displays in the Result column of the installation summary at the bottom of the page.
15. Remove the installation media from the drive.
16. Press F10 to exit SMIT.

Verifying the AIX software installation

To verify that the device driver for the adapter is installed, do the following steps:

1. If necessary, log in as root user.
2. Type `lslpp -l devices.pciex.14104003.rte` and press Enter.

If the device driver is installed, the following table is an example of the data that is shown.

Fileset	Level	State	Description
Path: /usr/lib/objrepos devices.pciex.14104003.rte	5.x.0.0	COMMITTED	2-Port 10/100/1000 Base-TX Ethernet PCI Express Adapter

3. Confirm that the `devices.pciex.14104003.rte` filesets are installed. If no data is shown in the window, reinstall the driver.

Installing the adapter

This section explains how to install the adapter. If you are installing the operating system at this time, install the adapter before you install the operating system. If the operating system is already installed and you must install the device driver for this adapter, install the device driver software before you install the adapter.

Attention: Before installing an adapter, review the precautions in Safety notices and Handling static sensitive devices. Do not remove the adapter from its anti-static package until you are ready to place it in the system unit.

To install the adapter, follow these steps:

1. Determine the PCIe slot in which to place the adapter.
The adapter has an x4 PCIe connector and can be placed in a x4, x8, or x16 slot. See the PCI adapter placement for information about the PCIe slots on your system unit.
2. Install the adapter by using the instructions in the system unit service guide.

Verifying the adapter installation

To verify that the system unit recognizes the adapter, type `lsdev -Cs pci` at the command line and press Enter.

A list of PCI devices displays. If the adapter is installed correctly, the status of available for each port indicates that the adapter is installed and ready to use. If a message indicates that any of the ports are defined instead of available, shut down the server and verify that the adapter was installed correctly.

Related tasks:

[Installing PCI adapters](#)

Related reference:

[IBM Prerequisite website](#)

[Parts information](#)

[PCI adapter placement](#)

“Backplane daughter cards and RAID enablement cards” on page 2

Find links to topics that cover Backplane daughter cards and RAID enablement cards.

2-Port Gigabit Ethernet-SX PCI Express Adapter (FC 5768; CCIN 5768)

Learn about features, requirements, and specifications for the 5768 adapter.

The 2-Port Gigabit Ethernet-SX PCI Express Adapter provides two 1 Gbps (1000 Base-SX) full-duplex Ethernet LAN connections. The adapter connects to a network using a standard shortwave multimode optical cable that conforms to the IEEE 802.3z standard. The adapter supports distances of 260 m for 62.5 micron Multi Mode Fiber (MMF) and 550 m for 50.0 micron MMF. AIX Network Installation Management (NIM) boot capability is supported with this adapter.

The adapter provides the following features:

- Supports interrupt moderation to deliver increased performance while significantly reducing processor utilization
- Supports dual port operation in almost any PCIe slot, except x1
- Supports auto-negotiation, full-duplex only
- Supports integrated media-access control (MAC) and physical layer (PHY)
- Supports Fast EtherChannel (FEC) with the existing software
- Supports gigabit EtherChannel (GEC) with the existing software
- Supports IEEE 802.3ad (Link Aggregation control protocol)
- Supports IEEE 802.1Q VLANs
- Supports IEEE 802.3 z, ab, u, x flow control support
- Supports IEEE 802.1p
- Supports IEEE 802.3ab for TX
- Supports TCP checksum offload transmission control protocol (TCP), user datagram protocol (UDP), Internet Protocol (IP) for IPv4 and IPv6
- Supports TCP segmentation or large send offload
- Supports EEPROM-SPI and single EEPROM

- Supports interrupt levels INTA and MSI
- Hardware certifications FCC B, UL, CE, VCCI, BSMI, CTICK, MIC
- Network Controller (MAC) Intel 82571EB
- Compliant with European Union Directive 2002/95/EC on the Restriction of the Use of Certain Hazardous Substances in Electrical and Electronic Equipment

Adapter specifications

Item Description

FRU number

10N6846*

*Designed to comply with RoHS requirement

I/O bus architecture

- PCI Express V1.0a compliant
- Bus width x4 lane PCI Express, operable in x4, x8, x16 slots
- Bus speed (x4, encoded rate) 10 Gbps unidirectional; 20 Gbps bidirectional

Busmaster

Yes

Maximum number

For the maximum adapters supported, see the PCI adapter placement topic collection for your system.

Adapter size

PCIe short form

Connector information

Two fiber optic ports, LC connector

LED status indicators for link activity and speed

Wrap plug

LC fiber optic, part number 12R9314

Cabling

Optional LC-SC converter cables are available:

- LC-SC 62.5 micron converter cable, part number 12R9322, FC 2459.
- LC-SC 50 micron use converter cable, part number 12R9321, FC 2456.

Adapter LED states

The LEDs on the adapter provide information about the adapter's operation status. The LEDs are visible through the adapter's mounting bracket. Figure 44 shows the location of the LEDs. Table 39 on page 130 describes the different LED states and what those states indicate. The following figure shows the adapter.

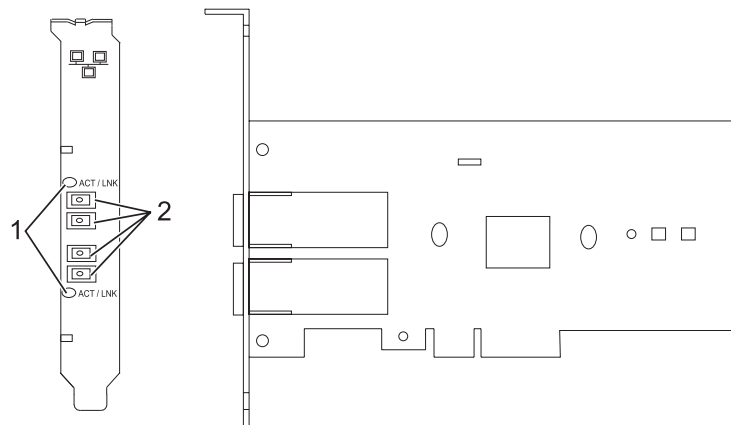

Figure 44. 2-Port Gigabit Ethernet-SX PCI Express Adapter

1 LEDs

2 Multimode Fiber LC receptacles

Table 39. Adapter LEDs and descriptions

LED	Description
Off	No link (The absence of a link could indicate a bad cable, bad connector, or a configuration mismatch.)
Green	Good link, no activity
Flashing Green	Good link, data activity

For details about slot priorities and placement rules, see the PCI adapter placement topic collection for your system.

Operating system or partition requirements

If you are installing a new feature, ensure that you have the software that is required to support the new feature and that you determine whether there are any prerequisites for this feature and attaching devices. To check for the prerequisites, see IBM Prerequisite website (www-912.ibm.com/e_dir/eServerPrereq.nsf).

The adapter is supported on the following versions of the operating systems:

- AIX
 - AIX Version 7.1, or later.
 - AIX Version 6.1, or later.
 - AIX Version 5.3, or later.
- Linux
 - Red Hat Enterprise Linux 5.6 for POWER, or later.
 - Novel SUSE Linux Enterprise Server 11, Service Pack 1, or later.
- IBM i
 - IBM i 7.1, or later.
 - IBM i 6.1, or later.

Preparing for installation

If you are installing the operating system at this time, install the adapter before you install the operating system. See *Installing the adapter* for instructions.

If you are installing only the device driver for this adapter, install the device driver software before you install the adapter. See “Installing the device driver software” on page 131 for instructions.

If you already have one of these adapters installed and working with your AIX operating system and you are preparing to install additional adapters, the device driver is already installed and you must not reinstall the device drive.

If you already have one of these adapters installed and working with your AIX operating system and you are preparing to install additional adapters, the device driver is already installed and you must not reinstall the device drive.

Verify you hardware requirements

The adapter requires the following hardware:

- A wrap plug for the multimode fiber connector, if you are running the total diagnostics package
- Shortwave (850 nm) 50/62.5 micron multimode fiber network attachment

The following table indicates the allowable cable lengths from the adapter to the gigabit Ethernet switch, including patch cables.

Table 40. Adapter cable information

Cable type	Physical connector type	Maximum range
62.5 m MMF	LC	260 meters
50 m MMF	LC	550 meters

Verify your software requirements

The adapter is supported on operating systems shown in Operating system or partition requirements. Ensure that your operating system supports this adapter before you install it. Contact service and support if you need assistance.

Gather tools and documentation

To install the adapter, make sure you have access to the following items:

- The adapter
- The operating system documentation
- The system unit documentation for removing and replacing features
- The PCI adapter placement documentation
- A flat-blade screwdriver
- The AIX base operating system CD, which includes the device driver, or the AIX device driver CD

Installing the device driver software

This section explains how to install device driver software. The device driver is provided for the AIX 5L operating system on the AIX base operating system CD or the AIX device driver CD.

To install device driver software, do the following steps:

1. Log in to the system unit as root user.
2. Insert the media containing the device driver software (for example, the CD) into the media device.
If your system does not have a CD-ROM drive, refer to your system documentation for performing a Network Installation Management (NIM) installation.
3. Type the following System Management Interface Tool (SMIT) fast path command: `smit devinst`
4. Press Enter. The Install Additional Device Software window highlights the **INPUT device / directory for software** option.
5. Type the name of the input device that you are using, or press F4 to select the input device from a list.
6. Press Enter. The Install Additional Device Software window highlights the SOFTWARE to install option.
7. Press F4 to select List.
8. Type / to display the Find window.
9. Type the device package name `devices.pciex.14103f03`.
10. Press Enter. The system finds and highlights this device driver software.
11. Press F7 to select the highlighted device driver software.
12. Press Enter. The INSTALL ADDITIONAL DEVICE SOFTWARE window displays. The entry fields are automatically updated.
13. Press Enter to accept the information. The ARE YOU SURE window displays.

14. Press Enter to accept the information. The COMMAND STATUS window displays.
 - The message RUNNING is highlighted to indicate that the installation and configuration command is in progress.
 - When RUNNING changes to OK, scroll to the bottom of the page and locate the installation summary.
 - After a successful installation, SUCCESS displays in the Result column of the installation summary at the bottom of the page.
15. Remove the installation media from the drive.
16. Press F10 to exit SMIT.

Verify the AIX software installation

To verify that the device driver for the adapter is installed, do the following steps:

1. If necessary, log in as root user.
2. Type `lslpp -l devices.pciex.14103f03.rte` and press Enter.

If the device driver is installed, the following is an example of the data that is displayed.

Fileset	Level	State	Description
Path: /usr/lib/objrepos devices.pciex.14103f03.rte	5.x.0.0	COMMITTED	2-Port Gigabit Ethernet-SX PCI Express® Adapter software

3. Confirm that the `devices.pciex.14103f03.rte` filesets are installed. If no data displays, try reinstalling the driver.

Installing the adapter

This section explains how to install the adapter. If you are installing the operating system at this time, install the adapter before you install the operating system. If the operating system is already installed and you must install the device driver for this adapter, install the device driver software before you install the adapter.

Attention: Before installing an adapter, review the precautions in Safety notices and Handling static sensitive devices. Do not remove the adapter from its anti-static package until you are ready to place it in the system unit.

To install the adapter, follow these steps:

1. Determine the PCIe slot in which to place the adapter.

The adapter has an x4 PCIe connector and can be placed in a x4, x8, or x16 slot. See the PCI adapter placement for information about the PCIe slots on your system unit.
2. Install the adapter by using the instructions in the system unit service guide.

Connecting to an Ethernet network

Refer to your local procedures for information about connecting the adapter to your Ethernet network.

Notes:

- Only one type of network can be attached to the adapter at one time.
- If your switch has an SC receptacle, you need an LC-SC converter cable.
- You must configure an IP network interface to enable the adapter to detect the link and illuminate the link LED.

To connect the adapter to a multimode fiber network, do the following steps:

1. Insert the male fiber LC connector of the fiber cable into the adapter LC connector.
2. Insert the male fiber LC connector of the other end of the cable into the network switch.

Verifying the adapter installation

To verify that the system unit recognizes the adapter, type `lsdev -Cs pci` at the command line and press Enter.

A list of PCI devices displays. If the adapter is installed correctly, the status of available for each port indicates that the adapter is installed and ready to use. If a message indicates that any of the ports are defined instead of available, shut down the server and verify that the adapter was installed correctly.

Related tasks:

[Installing PCI adapters](#)

Related reference:

[IBM Prerequisite website](#)

[Parts information](#)

[PCI adapter placement](#)

“Backplane daughter cards and RAID enablement cards” on page 2

Find links to topics that cover Backplane daughter cards and RAID enablement cards.

10 Gigabit Ethernet-SR PCI Express Adapter (FC 5769; CCIN 5769)

Learn about the features, operating system requirements, and installation procedures for the feature code (FC) 5769 adapter.

Overview

The 10 Gigabit Ethernet-SR PCIe Adapter is a low-profile, high performance fiber network interface controller (NIC). The product conforms to the IEEE, 802.3ae 10GBASE-SR specification for Ethernet transmission.

The following figure shows the adapter LED and network connector. The following figure shows the adapter.

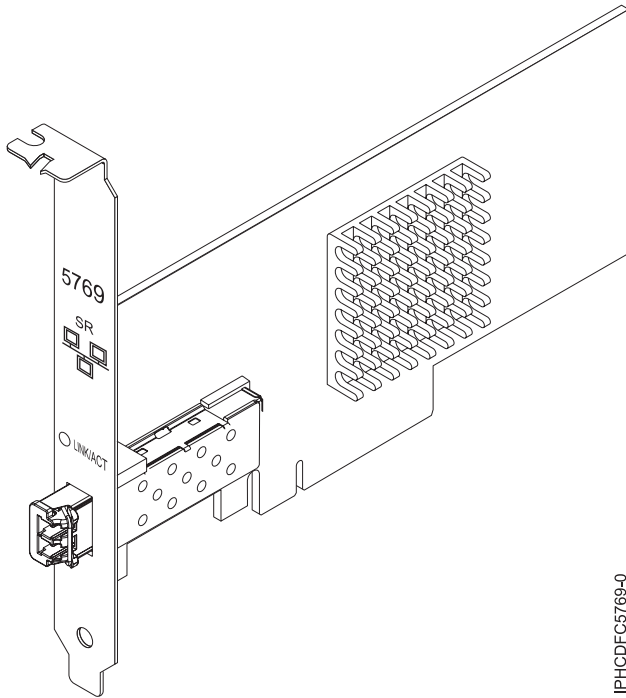

Figure 45. 10 Gigabit Ethernet-SR PCIe Adapter

The LED on the adapter provides information about the operation status of the adapter.

Table 41. Adapter LED

LED	Light	Description
Activity/Link	Green	Good link, no activity
	Flashing Orange	Transmit activity
	Off	No link*
Adapter card status	Red	Not initialized**
	Off	Initialized

*The absence of a link could be the result of a defective cable, a defective connector, or a configuration mismatch.

**The adapter has not been initialized by the operating system. During such time, the following conditions are true:

- If no cable is connected, the Green LED is **ON**.
- If cable is connected and the LINK is sensed, the Green LED is **OFF**.

For details about slot priorities and placement rules, see the PCI adapter placement topic collection for your system.

Specifications

Item Description

FRU number

46K7897 (Designed to comply with RoHS requirement.)

I/O bus architecture

PCIe-V1.1 x8

Busmaster

Yes

Maximum number

For the maximum adapters supported, see the PCI adapter placement topic collection for your system.

Adapter size

PCIe x8, short form

Connector information

LC multimode fiber optic

Wrap plug

LC wrap plug-d, part number 12R9314 (Designed to comply with RoHS requirement.)

Cables

Customers supply the cables. Optional LC-SC 62.5 micron converter cable, part number 12R9322, FC 2459, is available. For 50 micron LC-SC connections, use converter cable part number 12R9321, FC 2456.

Attributes

The adapter provide the following features:

- PCIe 1.1 x8
- MSI-X, MSI and support of traditional pin interrupts
- 10GBASE-SR short-reach optics (850 nm)
- IEEE 802.3ae (10 GbE)
- IEEE 802.1p priority and 802.1Q VLAN tagging
- IEEE 802.3x flow control
- Link aggregation, 802.3ad 802.3 compliance
- IEEE 802.3ad load-balancing and failover
- Ethernet II and 802.3 encapsulated frames
- Multiple MAC addresses per interface
- Jumbo frames up to 9.6 KB
- TCP checksum offload for IPv4 and IPv6
- TCP segmentation offload (TSO) for IPv4 and IPv6
- User datagram protocol (UDP) checksum offload for IPv4 and IPv6
- Receive side scaling and packet steering
- Line rate packet filtering and attack protection
- IETF RDDP and RDMAC iWARP compliance (Linux only)
- APIs: RNIC-PI, kDAPL and Open Fabrics Enterprise Distribution (OFED) 1.4 (Linux only)
- Full iSCSI software and hardware initiator support (Linux only)

Operating system or partition requirements

If you are installing a new feature, ensure that you have the software that is required to support the new feature and that you determine whether there are any prerequisites for this feature and attaching devices. To check for the prerequisites, see IBM Prerequisite website (www-912.ibm.com/e_dir/eServerPrereq.nsf).

This adapter is supported for the following versions of operating systems:

- AIX
 - AIX Version 6.1 with the 6100-03 Technology Level, or later
 - AIX Version 5.3 with the 5300-10 Technology Level, or later
- Linux
 - Red Hat Enterprise Linux Version 5 Update 3, or later
 - SUSE Linux Enterprise Server 11, or later

AIX host bus adapter (HBA) and Ethernet drivers are contained in the following filesets:

```
devices.ethernet.ct3  
devices.ethernet.ct3.rte //HBA  
devices.ethernet.ct3.cdli //ENT
```

Preparing for installation

If you are installing your operating system at this time, install your adapter before you install the operating system. If you are installing only the device driver for this adapter, install your device driver software before you install the adapter.

If you are running the total diagnostics package you need a wrap plug for the multimode fiber connector used for the adapter. To connect to a network, you need a shortwave (850 nm) 50/62.5 micron multimode fiber network attachment.

The following tables indicates the allowable cable lengths from the adapter to the gigabit Ethernet switch, including patch cables:

Table 42. Cable information

Fiber cable type	Connector type	Minimum modal bandwidth at 850 nm (MHz x km)	Operating range in meters
62.5 µm MMF	LC	160	2 to 26
		200	2 to 33
50 µm MMF	LC	400	2 to 66
		500	2 to 82
		2000	2 to 300

Ensure that your operating system supports this adapter before you install it. See “Operating system or partition requirements” on page 135.

Installing the AIX device driver software

To install device driver software, follow the steps in “Installing the AIX device driver software” on page 224.

Installing the adapter

For general instructions on how to install a PCI adapter, see the Installing PCI adapters topic. Return here to verify the adapter installation.

Verifying the adapter installation

To verify that your system recognizes the PCI adapter, do the following steps:

1. If necessary, log in as root user.
2. At the command line, type: `lsdev -Cs pci`
3. Press Enter.

A list of PCI devices is displayed. If the adapter is installed correctly, the status of available for each port indicates that the adapter is installed and ready to use. If a message indicates that any of the ports are defined instead of available, shut down your server and verify that the adapter was installed correctly.

Connecting to an Ethernet network

This section explains how to connect the adapter to the multimode fiber network. Refer to your local procedures for information about connecting the adapter to your Ethernet network.

Note: Only one type of network can be attached to the adapter at one time.

To connect the adapter to a multimode fiber network, do the following steps:

1. Insert the male fiber LC connector of the fiber cable into the adapter LC connector.
2. Insert the male fiber LC connector of the other end of the cable into the network switch.

Notes:

- The adapter requires an 850 nm multimode fiber optic cable. See Table 42 on page 136.
- If your switch has an SC receptacle, you need an LC-SC converter cable.
- It is necessary to configure an IP network interface to enable the adapter to detect a link and to illuminate the link LED.

Related tasks:

“Installing the AIX device driver software” on page 224

Learn how to install the AIX device driver software for a PCI adapter.

“Verifying the AIX device driver software” on page 225

Learn how to verify the AIX device driver is installed for a PCI adapter.

[🔗 Installing PCI adapters](#)

Related reference:

[🔗 IBM Prerequisite website](#)

[🔗 Parts information](#)

[🔗 PCI adapter placement](#)

“Backplane daughter cards and RAID enablement cards” on page 2

Find links to topics that cover Backplane daughter cards and RAID enablement cards.

10 Gigabit Ethernet-LR PCI Express Adapter (FC 5772; CCIN 576E)

Learn about the features, operating system requirements, and installation notes for the feature code (FC) 5772 adapter.

Overview

The 10 Gigabit Ethernet-LR PCI Express Adapter is a low-profile, fiber network interface controller (NIC). This adapter is based on the dual port 82598EB 10 GbE controller. The product conforms to the IEEE 802.3 standard and supports standards for system manageability and power management. Additionally, it conforms to the 802.3ae 10GBASE-LR specification for Ethernet transmissions over 1310 nm single-mode fiber optic cable for distances up to 10 kilometers.

The following figure shows the adapter LEDs and network connector.

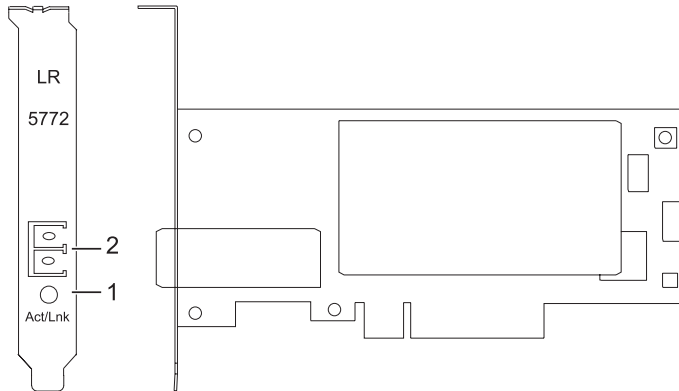

Figure 46. 10 Gigabit Ethernet-LR PCI Express Adapter

- 1 Activity/Link LED
- 2 Multimode fiber LC receptacle

Specifications

Item Description

FRU number
10N9034 (Designed to comply with RoHS requirement.)

I/O bus architecture
PCI-Express V1.1 and v2.0 (gen 1 only)

Busmaster
Yes

Maximum number
For the maximum adapters supported, see the PCI adapter placement topic collection for your system.

Adapter size
PCIe short form

Connector information
LC single mode fiber optic

Wrap plug
LC fiber optic, part number 12R9313

Cables
Customers supply the cables.

For details about slot priorities and placement rules, see the PCI adapter placement topic collection for your system.

Operating system or partition requirements

If you are installing a new feature, ensure that you have the software that is required to support the new feature and that you determine whether there are any prerequisites for this feature and attaching devices. To check for the prerequisites, see IBM Prerequisite website (www-912.ibm.com/e_dir/eServerPrereq.nsf).

The adapter is supported on the following versions of the operating systems:

- AIX
 - AIX 7.1, or later
 - AIX 6.1, or later
 - AIX 5.3, or later
- Linux

- Red Hat Enterprise Linux 5.6 for POWER, or later
- SUSE Linux Enterprise Server 11 Service Pack 1, or later
- IBM i
 - IBM i 7.1, or later
 - IBM i 6.1, or later

Preparing for installation

This section helps you prepare to install your adapter. Preparing to install the adapter involves the following tasks:

- Verifying your hardware requirements
- Verifying your software requirements
- Gathering tools and documentation

If you are installing your operating system at this time, install your adapter before you install the operating system. See “Installing the adapter” on page 141 for instructions.

If you are installing only the device driver for this adapter, install your device driver software before you install the adapter. See “Installing the device driver software” on page 140 for instructions.

Verifying your hardware requirements

The adapter requires the following hardware:

- If you are running the total diagnostics package you will need a wrap plug for the single mode fiber connector used on the LR adapter.
- To connect to a network you will need a 1310 nm single mode fiber network attachment for the LR adapter.

The following tables indicates the allowable cable lengths from the adapter to the gigabit Ethernet switch, including patch cables:

Table 43. 10 Gigabit Ethernet-LR PCI Express Adapter cable information

Fiber cable type	Connector type	Operating range in meters
9 μ m SMF	LC	10 Km

Verifying your software requirements

Ensure that your operating system supports this adapter before you install it. See “Operating system or partition requirements” on page 138.

Gathering tools and documentation

To install the adapter, make sure you have access to the following items:

- The adapter
- The operating system documentation
- The system unit documentation
- The PCI adapter placement information for the system unit
- Wrap plugs
- A flat-blade screwdriver
- The operating system CD, which includes the device driver, or the device driver CD-ROM

Installing the device driver software

This section explains how to install device driver software for the adapter. The device driver is provided for the AIX operating system.

Be sure you have read “Preparing for installation” on page 139 to determine which of the following tasks to do:

- If you should install your device driver software first, go to step 1 of this section.
- If you should install your adapter hardware first, go to “Installing the adapter” on page 141. When you install AIX, your adapter device driver is automatically installed.

To install device driver software, do the following steps:

1. Log in to the system unit as root user.
2. Insert the media that contains the device driver software (for example, a CD-ROM) into the appropriate media device.
3. Type the following System Management Interface Tool (SMIT) fast path: `smitty devinst`
4. Press Enter. The Install Additional Device Software screen highlights the INPUT device/directory for software option.
5. Select or type your input device:
 - Press F4 to display the input device list.
 - Select the name of the device (for example, CD-ROM) that you are using and press Enter.or
 - In the entry field, type the name of the input device you are using and press Enter.
 - The Install Additional Device Software window highlights the SOFTWARE to install option.
6. Press F4 to display the SOFTWARE to install window.
7. Type the following to display the Find window: `/`
8. Type the device package name: `devices.pciex.8680c71014108003.rte`.
9. Press Enter. The system finds and highlights this device driver software.
10. Press F7 to select the highlighted device driver software.
11. Press Enter. The INSTALL ADDITIONAL DEVICE SOFTWARE window is shown. The entry fields are automatically updated.
12. Press Enter to accept the information. The ARE YOU SURE window is shown.
13. Press Enter to accept the information. The COMMAND STATUS window is shown.
 - The term RUNNING is highlighted to indicate that the installation and configuration command is in progress.
 - When RUNNING changes to OK, scroll to the bottom of the page and locate the Installation Summary.
 - After a successful installation, SUCCESS is displayed in the Result column of the Installation Summary at the bottom of the page.
14. Remove the installation media from the drive.
15. Press F10 to exit SMIT.
16. Go to the adapter installation procedure, “Installing the adapter” on page 141.

Verify AIX software installation

To verify that the device driver for the adapter is installed, do the following steps:

1. If necessary, log in as root user.
2. At the command line, type `lslpp -l devices.pciex.8680c71014108003.rte`.
3. Press Enter.

If the adapter device driver is installed, the following is an example of the data that is displayed on the window:

Fileset	Level	State	Description
Path: /usr/lib/objrepos devices.pciex.8680c71014108003.rte	5.3.8.0	COMMITTED	10 Gigabit Ethernet-LR PCI Express Adapter Software

Verify that the file sets are installed at the AIX version level you are running. Level 5.3.8.0 is an example. If the correct information is displayed, continue to the next section, Installing the adapter. If no data is displayed on your screen, the adapter device driver did not install correctly. Try reinstalling the driver.

Installing the adapter

For instructions on how to install PCI adapters, see Installing the PCI adapters topic.

Verifying the adapter installation

To verify that your system unit recognizes the PCI adapter, do the following steps:

1. If necessary, log in as root user.
2. At the command line, type: `lsdev -Cs pci`
3. Press Enter.

A list of PCI devices are displayed. If the adapter is installed correctly, an Available status for each port indicates that the adapter is installed and ready to use. If the message on your screen indicates that any of the ports are DEFINED instead of AVAILABLE, shut down your server and verify that the adapter was installed correctly.

Connecting to an Ethernet network

This section explains how to connect the adapter to the multimode fiber network. Refer to your local procedures for information about connecting the adapter to your Ethernet network.

Note: Only one type of network can be attached to the adapter at one time.

To connect the adapter to a multimode fiber network, do the following steps:

1. Insert the male fiber LC connector of the fiber cable into the adapter LC connector.
2. Insert the male fiber LC connector of the other end of the cable into the network switch.

Notes:

- The adapter requires a 1310 nm single-mode fiber optic cable. See Table 43 on page 139.
- If your switch has an SC receptacle, you need an LC-SC converter cable.
- It is necessary to configure an IP network interface to enable the adapter to detect a link and to illuminate the link LED.

Adapter LEDs

The LEDs on the adapter provide information about the operation status of the adapter. The LEDs are visible through the mounting bracket and, when lit, indicate the following conditions:

Table 44. Adapter LEDs

LED	Light	Description
Activity/Link	Green	Good link, no activity
	Blinking	Transmit activity
	Off	No link [*]

^{*}The absence of a link could be the result of a defective cable, a defective connector, or a configuration mismatch.

Related tasks:

[Installing PCI adapters](#)

Related reference:

[IBM Prerequisite website](#)

[Parts information](#)

[PCI adapter placement](#)

“Backplane daughter cards and RAID enablement cards” on page 2

Find links to topics that cover Backplane daughter cards and RAID enablement cards.

PCIe2 4-port 1 GbE Adapter (FC 5899; CCIN 576F)

Learn about the specifications and operating system requirements for the feature code (FC) 5899 adapters.

Overview

The PCIe2 LP 4-port 1 GbE Adapter is a full-height, generation-2 PCIe adapter. This adapter provides four 1-Gb Ethernet ports that can be configured to run at 1000 megabits per second (Mbps) (or 1 gigabit per second (Gbps)), 100 Mbps, or 10 Mbps. The adapter connects to a network that uses unshielded twisted pair (UTP) cable for distances of up to 100 meters (328.08 feet). The adapter supports AIX Network Installation Management (NIM) boot capability. The adapter conforms to the IEEE 802.3ab 1000Base-T standard. The adapter supports jumbo frames when running at the 1000 Mbps speed.

Each of the Ethernet ports can be connected by using:

- CAT5e (or later) UTP cables for 1000 Mbps network attachment
- CAT5 or CAT3 UTP cables for 100 Mbps or 10 Mbps network attachment

The cables are attached to the copper RJ45 connectors. Each port is independent of one another and supports full-duplex or half-duplex. The half-duplex mode does not support a speed of 1000 Mbps.

The adapter provides the following features:

- Supports interrupt moderation to deliver increased performance while significantly reducing processor utilization
- Supports dual port operation in almost any PCIe slot, except x1
- Supports auto-negotiation, full-duplex only
- Supports integrated media-access control (MAC) and physical layer (PHY)
- Supports Fast EtherChannel (FEC) with the existing software
- Supports gigabit EtherChannel (GEC) with the existing software
- Supports IEEE 802.3ad (Link Aggregation control protocol)
- Supports IEEE 802.1Q VLANs
- Supports IEEE 802.3 z, ab, u, x flow control support
- Supports IEEE 802.1p
- Supports IEEE 802.3ab for TX

- Supports TCP checksum offload transmission control protocol (TCP), user datagram protocol (UDP), Internet Protocol (IP) for IPv4 and IPv6
- Supports TCP segmentation or large send offload
- Supports EEPROM-SPI and single EEPROM
- Supports interrupt levels INTA and MSI
- Hardware certifications FCC B, UL, CE, VCCI, BSMI, CTICK, MIC
- Network Controller (MAC) Intel 82571EB
- Compliant with European Union Directive 2002/95/EC on the Restriction of the Use of Certain Hazardous Substances in Electrical and Electronic Equipment

Specifications

Item Description

Adapter FRU number

74Y4064 (Designed to comply with RoHS requirement)

Wrap plug

10N7405

I/O bus architecture

PCIe2.0, x4

Slot requirement

One PCIe x4 slot.

Cables

4-pair, CAT5e, UTP cables are connected to copper RJ45 connectors.

Voltage

3.3 V

Form factor

Short, full-height

Maximum number

For the maximum adapters supported, see the PCI adapter placement topic collection for your system.

Connector information

- Two RJ-45 ports
- Two LED adapter status indicators per port, for link activity and speed

Attributes provided

- PCIe x4, generation-1 or generation-2
- 4-Port machine access code (MAC)
- High performance IPV4/IPV6 checksum offload
- Large Send and Large Receive Support
- Multiple Queues
- VIOS

The following figure shows the adapter.

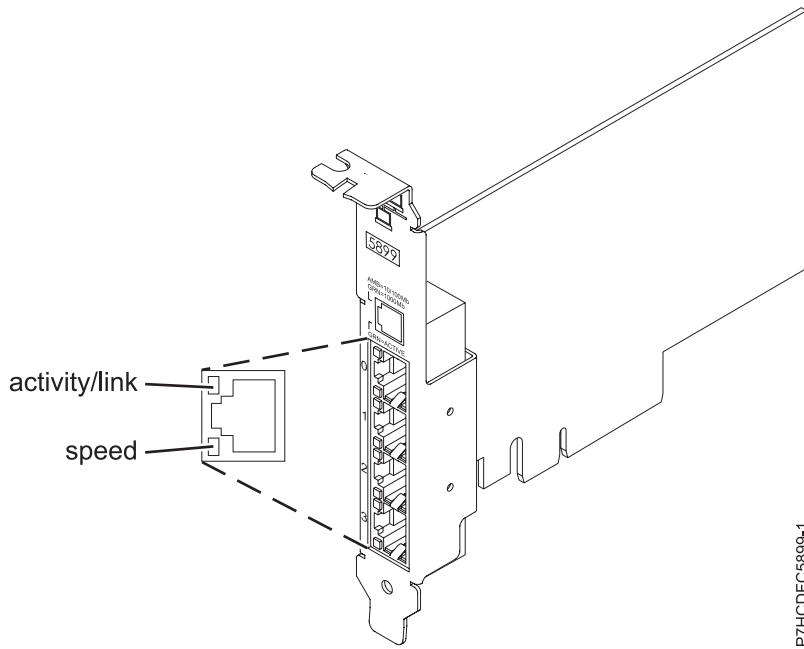

Figure 47. Adapter

Adapter LED states

The LEDs on the adapter provide information about the operation status of the adapter. The LEDs are visible through the mounting bracket. Figure 47 shows the location of the LEDs. Table 45 describes the different LED states and what those states indicate.

Table 45. Adapter LEDs and descriptions

LED	Light	Description
Speed	Yellow	10 Mbps or 100 Mbps
	Green	1000 Mbps or 1 Gbps
Activity/link	Green flashing	Active link or data activity
	Off	No link The absence of a link can indicate a defective cable, defective connector, or a configuration mismatch.

Operating system or partition requirements

This adapter is supported for the following versions of operating systems:

- AIX
 - AIX Version 7.1 with the 7100-01 Technology Level and Service Pack 4, or later.
 - AIX Version 7.1 with the 7100-00 Technology Level and Service Pack 6, or later.
 - AIX Version 6.1 with the 6100-07 Technology Level, and Service Pack 4, or later.
 - AIX Version 6.1 with the 6100-06 Technology Level, and Service Pack 8, or later.
 - AIX Version 5.3 with the 5300-12 Technology Level and Service Pack 6, or later.
- Linux
 - Red Hat Enterprise Linux 6.2, or later.
 - Red Hat Enterprise Linux 5.8, or later.

- SUSE Linux Enterprise Server 11, Service Pack 2, or later (with update package).
- For support details, see the Linux Alert website (www14.software.ibm.com/webapp/set2/sas/f/lopdiags/info/LinuxAlerts.htm)
- IBM i
 - IBM i 7.1, or later.
 - IBM i 6.1 with 6.1.1 machine code 6.1.1, or later.
- VIOS
 - VIOS support requires VIOS 2.2.1.4, or later.

Related tasks:

[🔗 Installing PCI adapters](#)

Related reference:

[🔗 IBM Prerequisite website](#)

[🔗 Parts information](#)

[🔗 PCI adapter placement](#)

“Backplane daughter cards and RAID enablement cards” on page 2

Find links to topics that cover Backplane daughter cards and RAID enablement cards.

PCIe LP 2-Port 1GbE TX Adapter (FC 9056; CCIN 5767)

Learn about features, requirements, and specifications for the feature code (FC) 9056 adapter.

The PCIe LP 2-Port 1GbE TX adapter is a low-profile, full-duplex, dual port, gigabit Ethernet adapter. This adapter is the low-profile adapter and FC 9055 is the regular-height adapter. Both adapters are the low-priced equivalents of the FC 5767.

The adapter interfaces to the system via a PCIe bus. This adapter can be configured to run each port at 10, 100, or 1000 Mbps data rates. The adapter connects to a network using a 4-pair CAT-5 Unshielded Twisted Pair (UTP) cable for distances of up to 100 meters (328.08 feet). This adapter is PCIe x4 capable and conforms to the PCIe 1.0a standard. The adapter supports AIX Network Installation Management (NIM) boot capability. The adapter conforms to the IEEE 802.3ab 1000Base-T standard. The adapter supports jumbo frames when running at the 1000 Mbps speed. The adapter does not support a speed of 1000 Mbps speed in half-duplex (HDX) mode.

The adapter provides the following features:

- Supports interrupt moderation to deliver increased performance while significantly reducing processor utilization
- Supports dual port operation in almost any PCIe slot, except x1
- Supports auto-negotiation, full-duplex only
- Supports integrated media-access control (MAC) and physical layer (PHY)
- Supports Fast EtherChannel (FEC) with the existing software
- Supports gigabit EtherChannel (GEC) with the existing software
- Supports IEEE 802.3ad (Link Aggregation control protocol)
- Supports IEEE 802.1Q VLANs
- Supports IEEE 802.3 z, ab, u, x flow control support
- Supports IEEE 802.1p
- Supports IEEE 802.3ab for TX
- Supports TCP checksum offload transmission control protocol (TCP), user datagram protocol (UDP), Internet Protocol (IP) for IPv4 and IPv6
- Supports TCP segmentation or large send offload

- Supports EEPROM-SPI and single EEPROM
- Supports interrupt levels INTA and MSI
- Hardware certifications FCC B, UL, CE, VCCI, BSMI, CTICK, MIC
- Network Controller (MAC) Intel 82571EB
- Compliant with European Union Directive 2002/95/EC on the Restriction of the Use of Certain Hazardous Substances in Electrical and Electronic Equipment

Adapter specifications

Item Description

FRU number
10N6845*

*Designed to comply with RoHS requirement

I/O bus architecture

- PCI Express V1.0a compliant
- Bus width x4 lane PCI Express, operable in x4, x8, x16 slots
- Bus speed (x4, encoded rate) 10 Gbps unidirectional; 20 Gbps bidirectional

Busmaster

Yes

Maximum number

For the maximum adapters supported, see the PCI adapter placement topic collection for your system.

Adapter size

PCIe short form

Connector information

- Two RJ-45 ports
- Two LED adapter status indicators per port, for link activity and speed

Wrap plug

RJ-45, part number 10N7405

Cabling

Customers supply their own cables. For best performance, use cables that meet CAT5e cabling standards, or later.

Adapter LED states

The LEDs on the adapter provide information about the operation status of the adapter. The LEDs are visible through the mounting bracket. 2-Port 10/100/1000 Base-TX Ethernet PCI Express Adapter shows the location of the LEDs. Table 46 on page 147 describes the different LED states and what those states indicate. The following figure shows the adapter.

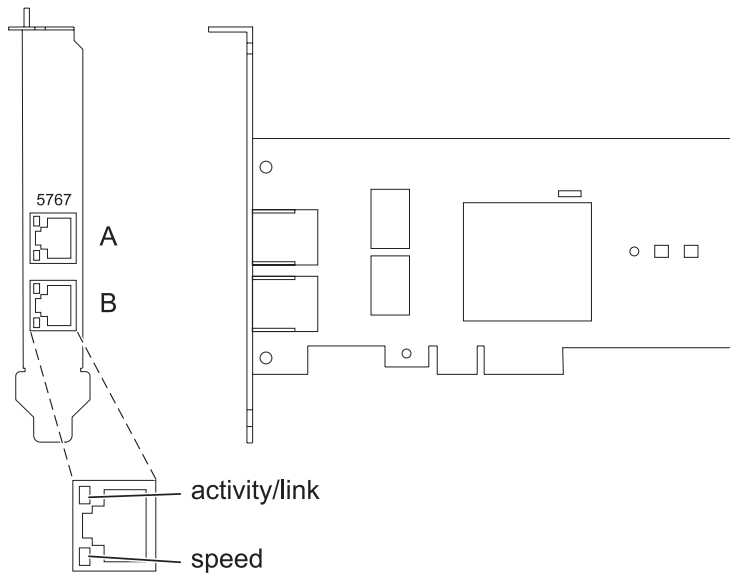

Figure 48. PCIe LP 2-Port 1GbE TX adapter

Table 46. Adapter LEDs and descriptions

LED	Light	Description
Activity/link	Green	Active link
	Off	No link The absence of a link can indicate a defective cable, defective connector, or a configuration mismatch.
	Flashing	Data activity
Speed	Off	10 Mbps
	Green	100 Mbps
	Orange	1000 Mbps

For details about slot priorities and placement rules, see the PCI adapter placement topic collection for your system.

Operating system or partition requirements

If you are installing a new feature, ensure that you have the software that is required to support the new feature and that you determine whether there are any prerequisites for this feature and attaching devices. To check for the prerequisites, see IBM Prerequisite website (www-912.ibm.com/e_dir/eServerPrereq.nsf).

The adapter is supported on the following versions of the operating systems:

- AIX
 - AIX Version 7.1, or later.
 - AIX Version 6.1, or later.
 - AIX Version 5.3, or later.
- Linux
 - Red Hat Enterprise Linux 5.6 for POWER, or later.
 - Novel SUSE Linux Enterprise Server 11, Service Pack 1, or later.
- IBM i

- IBM i 7.1, or later.
- IBM i 6.1, or later.

Preparing for installation

If you are installing the operating system at this time, install the adapter before you install the operating system. See “Installing the adapter” on page 149 for instructions.

If you are installing only the device driver for this adapter, install the device driver software before you install the adapter. See “Installing the device driver software” for instructions.

If you already have one of these adapters installed and working with your AIX operating system and you are preparing to install additional adapters, the device driver is already installed and you must not reinstall the device drive.

Verifying the hardware requirements

The adapter requires the following hardware:

- A wrap plug for the RJ-45 connector, if you are running the total diagnostics package.
- CAT5e (or later) UTP cables for 1000 Mbps network attachment.
- CAT5 or CAT3 UTP cables for 100 Mbps or 10 Mbps network attachment.

Restriction: The cables can be no longer than 100 meters (328.08 feet) (including patch cables) from the adapter to the local switch.

Verifying the software requirements

You can use the adapter on operating systems shown in “Operating system or partition requirements” on page 147.

Gathering tools and documentation

To install the adapter, ensure that you have access to the following items:

- The adapter
- The operating system documentation
- The system unit documentation for removing and replacing features
- The PCI adapter placement documentation
- A flat-blade screwdriver
- The AIX base operating system CD, which includes the device driver, or the AIX device driver CD

Installing the device driver software

This section explains how to install device driver software. The device driver is provided for the AIX 5L operating system on the AIX base operating system CD, which includes the device driver, or the AIX device driver CD.

To install device driver software, do the following steps:

1. Log in to the system unit as root user.
2. Insert the media containing the device driver software (for example, the CD) into the media device.
If your system does not have a CD-ROM drive, refer to your system documentation for performing a Network Installation Management (NIM) installation.
3. Type the following System Management Interface Tool (SMIT) fast path command: `smit devinst`

4. Press Enter. The Install Additional Device Software window highlights the **INPUT device / directory for software** option.
5. Type the name of the input device that you are using, or press F4 to select the input device from a list.
6. Press Enter. The Install Additional Device Software window highlights the **SOFTWARE** to install option.
7. Press F4 to select List.
8. Type / to display the Find window.
9. Type the device package name `devices.pciex.14104003`.
10. Press Enter. The system finds and highlights this device driver software.
11. Press F7 to select the highlighted device driver software.
12. Press Enter. The **INSTALL ADDITIONAL DEVICE SOFTWARE** window displays. The entry fields are automatically updated.
13. Press Enter to accept the information. The **ARE YOU SURE** window displays.
14. Press Enter to accept the information. The **COMMAND STATUS** window displays.
 - The message **RUNNING** is highlighted to indicate that the installation and configuration command is in progress.
 - When **RUNNING** changes to **OK**, scroll to the bottom of the page and locate the installation summary.
 - After a successful installation, **SUCCESS** displays in the Result column of the installation summary at the bottom of the page.
15. Remove the installation media from the drive.
16. Press F10 to exit SMIT.

Verifying the AIX software installation

To verify that the device driver for the adapter is installed, do the following steps:

1. If necessary, log in as root user.
2. Type `lspp -l devices.pciex.14104003.rte` and press Enter.

If the device driver is installed, the following table is an example of the data that is shown.

Fileset	Level	State	Description
Path: /usr/lib/objrepos devices.pciex.14104003.rte	5.x.0.0	COMMITTED	<i>adapter description</i>

3. Confirm that the `devices.pciex.14104003.rte` filesets are installed. If no data is shown in the window, reinstall the driver.

Installing the adapter

This section explains how to install the adapter. If you are installing the operating system at this time, install the adapter before you install the operating system. If the operating system is already installed and you must install the device driver for this adapter, install the device driver software before you install the adapter.

Attention: Before installing an adapter, review the precautions in Safety notices and Handling static sensitive devices. Do not remove the adapter from its anti-static package until you are ready to place it in the system unit.

To install the adapter, follow these steps:

1. Determine the PCIe slot in which to place the adapter.

The adapter has an x4 PCIe connector and can be placed in a x4, x8, or x16 slot. See the PCI adapter placement for information about the PCIe slots on your system unit.

2. Install the adapter by using the instructions in the system unit service guide.

Verifying the adapter installation

To verify that the system unit recognizes the adapter, type `lsdev -Cs pci` at the command line and press Enter.

A list of PCI devices displays. If the adapter is installed correctly, the status of available for each port indicates that the adapter is installed and ready to use. If a message indicates that any of the ports are defined instead of available, shut down the server and verify that the adapter was installed correctly.

Related tasks:

[Installing PCI adapters](#)

Related reference:

[IBM Prerequisite website](#)

[Parts information](#)

[PCI adapter placement](#)

“Backplane daughter cards and RAID enablement cards” on page 2

Find links to topics that cover Backplane daughter cards and RAID enablement cards.

PCIe2 LP 2-Port 10 GbE RoCE SFP+ Adapter (FC EC27 and FC EC28)

Learn about the specifications and operating system requirements for the feature code (FC) EC27 and FC EC28 adapters.

Overview

The FC EC27 and FC EC28 are the same adapter. FC EC28 is a full-height adapter, and the FC EC27 is a low-profile adapter. The names of these two adapters are:

- FC EC27: PCIe2 LP 2-Port 10 GbE RoCE SFP+ adapter
- FC EC28: PCIe2 2-Port 10 GbE RoCE SFP+ adapter

The adapter is a PCIe generation-2 (PCIe2), dual port, 10-Gigabit Ethernet (GbE) adapter with a PCIe 2.0 host bus interface. The adapter delivers high-bandwidth and low-latency 10 GbE connectivity. The adapter is optimized for high-transaction databases, cloud computing, virtualization, storage, and other data center applications. The adapter improves network performance by increasing available bandwidth to the central processing unit (CPU) and providing enhanced performance. The two 10 Gb small form-factor pluggable (SFP+) transceiver ports are used for connectivity with other servers or switches in the network. Each SFP+ port provides Ethernet connectivity with a nominal data rate of 10 gigabits per second (Gbps), and uses the SFP+ copper twinaxial cables up to 5 m (16.4 ft) in length. The link aggregation and failover features of the adapter are ideal for critical network applications that require redundancy and high availability.

For details about slot priorities and placement rules, see the PCI adapter placement topic collection for your system.

Specifications

Item	Description
------	-------------

Adapter FRU number	
---------------------------	--

	FC EC27: 74Y1988 (Designed to comply with RoHS requirement)
--	---

	FC EC28 74Y1987 (Designed to comply with RoHS requirement)
--	--

I/O bus architecture

PCIe2 x8

Slot requirement

For the slot priorities, see the PCI adapter placement topic collection for your system.

Cables

See “Cables” for details

Voltage

3.3 V

Form factor

Short

Maximum number

For the maximum adapters supported, see the PCI adapter placement topic collection for your system.

Limitations

This adapter cannot be used to boot an LPAR via AIX NIM or Linux Network Install. Systems that require installation from a network source must be configured with another Ethernet adapter that supports boot capability.

Operating system or partition requirements

This adapter is supported for the following versions of the operating system:

- AIX:
 - AIX Version 7.1 with the 7100-01 Technology Level and Service Pack 3, or later
 - AIX Version 6.1 with the 6100-07 Technology Level and Service Pack 3, or later
- Linux:
 - Red Hat Enterprise Linux Version 6.3 for POWER, or later, with current maintenance updates available from Red Hat.
 - SUSE Linux Enterprise Server 11 Service Pack 2, or later, with current maintenance updates available from SuSE.
- Firmware level 7.6, or later.

Cables

Feature codes EC27 and EC28 require the use of compatible SFP+, 10 Gbps, copper, twinaxial, active, Ethernet cables. See Figure 49 on page 152 for a view of the cable top and cable bottom. These cables are compliant with industry standard specifications SFF-8431 Rev 4.1 and SFF-8472 Rev 10.4, and all applicable IBM requirements.

Note: These cables are EMC Class A compliant.

See Table 47 on page 152 for details about the feature codes.

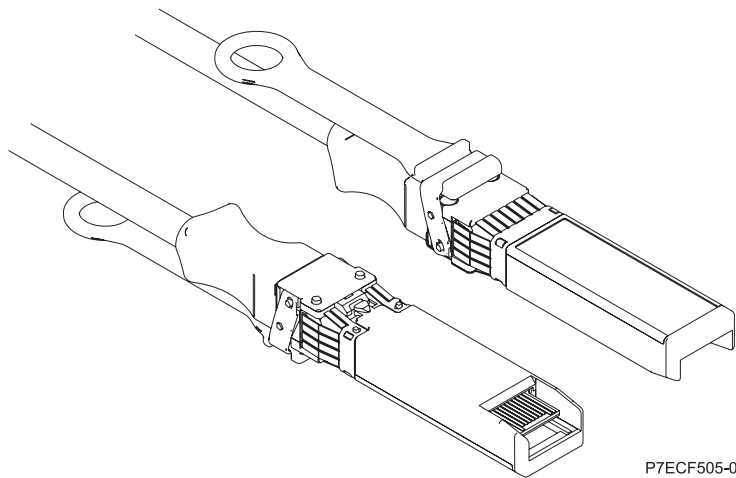

Figure 49. Top and bottom view of the cable

Table 47. Feature code and part number for varying lengths of the cable

Cable length	1 m (3.28 ft)	3 m (9.84 ft)	5 m (16.4 ft)
Feature code	EN01	EN02	EN03
CCIN	EF01	EF02	EF03
Part number	46K6182	46K6183	46K6184

Related tasks:

[Installing PCI adapters](#)

Related reference:

[IBM Prerequisite website](#)

[Parts information](#)

[PCI adapter placement](#)

“Backplane daughter cards and RAID enablement cards” on page 2

Find links to topics that cover Backplane daughter cards and RAID enablement cards.

PCIe2 LP 2x10Gb FCoE 2x1GbE SFP+ Adapter (FC EN0J; CCIN 2B93)

Learn about the specifications and operating system requirements for the feature code (FC) EN0J adapters.

Overview

The PCIe2 LP 2x10Gb FCoE 2x1GbE SFP+ Adapter is a PCI Express (PCIe) generation 2, low-profile capable adapter. The adapter has four-ports and is a Fibre Channel over Ethernet (FCoE) converged network adapter (CNA). This adapter provides a PCIe 2.0 host bus interface. The adapter is a high-performance adapter that consolidates traffic for networking and Fibre Channel storage. The adapter is optimized for cloud computing, virtualization, storage, and other data center applications. Both FCoE and network interface controller (NIC) functions are available for both FCoE ports. Use of the FCoE requires that you use convergence enhanced Ethernet (CEE) switches. The link aggregation and failover features of the adapter make it suitable for critical network applications that require redundancy and high availability.

The four-port adapter provides two 10 Gb FCoE SR small form-factor pluggable (SFP+) ports and two 1 Gb RJ45 Ethernet ports. The two 10 Gb FCoE ports are connected by little connector-type (LC) connectors.

Each FCoE port provides Ethernet connectivity with a nominal data rate of 10 Gbps (gigabits per second). Each of the 1 Gb ports provides Ethernet connectivity at a data rate of 1 Gbps and is connected with Ethernet cables. A 10 Mb data rate is not supported. Figure 50 shows the FC EN0J adapter.

Restriction: The 1 Gb Ethernet ports do not support data rates of 10 Mbps (megabits per second).

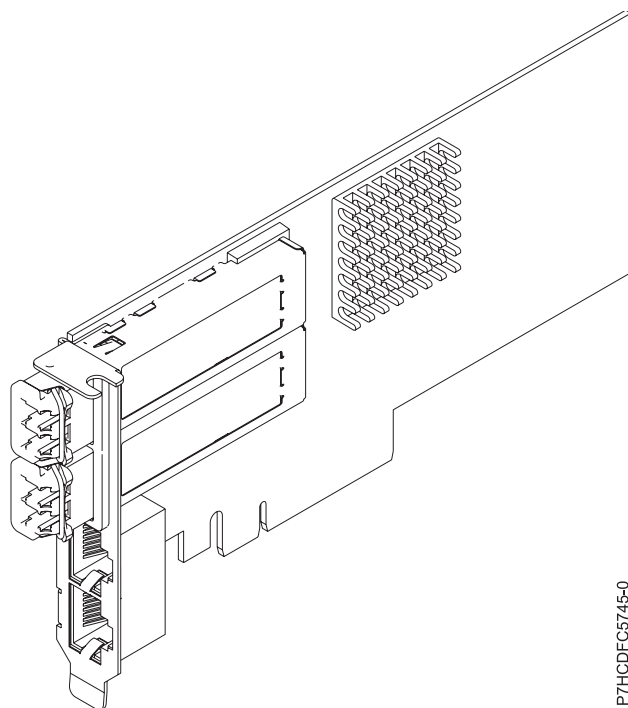

P7HCDFC5745-0

Figure 50. FC EN0J adapter

Specifications

Item Description

Adapter FRU number

00E3498 (Designed to comply with RoHS requirement)

Wrap plug FRU number

12R9314 (for Fibre LC connector)

10N7405 (for RJ45 connector)

I/O bus architecture

PCIe2 x8

Slot requirement

For details about slot priorities and placement rules, see the PCI adapter placement topic collection for your system.

Cables

SR SFP+ optical fiber cables and Cat5 Ethernet cables

Voltage

3.3 V, 12 V

Form factor

Short, regular sized bracket, low-profile capable

Maximum number

For the maximum adapters supported, see the PCI adapter placement topic collection for your system.

Operating system or partition requirements

If you are installing a new feature, ensure that you have the software that is required to support the new feature and that you determine whether there are any prerequisites for this feature and attaching devices. To check for the prerequisites, see IBM Prerequisite website (www-912.ibm.com/e_dir/eServerPrereq.nsf).

The adapter is supported on the following versions of the operating systems:

- AIX
 - AIX 7.1, or later
 - AIX 6.1, or later
- Linux
 - Red Hat Enterprise Linux
 - SUSE Linux Enterprise Server
 - For support details, see the Linux Alert website (www14.software.ibm.com/webapp/set2/sas/f/lopdiags/info/LinuxAlerts.htm)
- IBM i
 - IBM i 7.1, or later
 - IBM i 6.1, or later

Related tasks:

[Installing PCI adapters](#)

Related reference:

[IBM Prerequisite website](#)

[Parts information](#)

[PCI adapter placement](#)

“Backplane daughter cards and RAID enablement cards” on page 2

Find links to topics that cover Backplane daughter cards and RAID enablement cards.

PCIe2 LP 4-port (10 Gb FCoE and 1 GbE) Copper and RJ45 Adapter (FC EN0L; CCIN 2CC1)

Learn about the specifications and operating system requirements for the feature code (FC) EN0L adapters.

Overview

The PCIe2 LP 4-port (10 Gb FCoE and 1 GbE) Copper and RJ45 Adapter is a PCI Express (PCIe) generation 2, low-profile adapter. The adapter has four-ports and is a Fibre Channel over Ethernet (FCoE) converged network adapter (CNA). This adapter provides a PCIe 2.0 host bus interface. The adapter is a high-performance adapter that consolidates traffic for networking and Fibre Channel storage. The adapter is optimized for cloud computing, virtualization, storage, and other data center applications. Both the FCoE and network interface controller (NIC) functions are available for all the four ports. Use of the FCoE requires that you use convergence enhanced Ethernet (CEE) switches. The link aggregation and failover features of the adapter make it suitable for critical network applications that require redundancy and high availability.

The four-port adapter provides two 10 Gb FCoE Copper Twin-axial ports and two 1 Gb RJ45 Ethernet ports. The two 10 Gb FCoE ports are connected by little connector-type (LC) connectors. Each FCoE port provides Ethernet connectivity with a nominal data rate of 10 Gbps (gigabits per second). Each of the 1 Gb ports provides Ethernet connectivity at a data rate of 1 Gbps and is connected with Ethernet cables. A 10 Mb data rate is not supported. Figure 51 on page 155 shows the FC EN0L adapter.

Restriction: The 1 Gb Ethernet ports do not support data rates of 10 Mbps (megabits per second).

The adapter is SR-IOV (Single Root I/O Virtualization) capable. The adapter can function as a boot adapter. The adapter supports all Fibre Channel and Ethernet topologies.

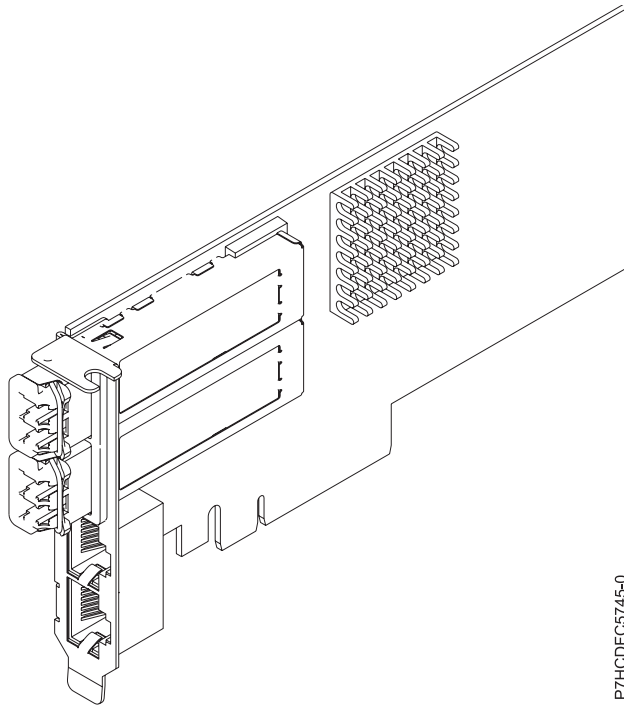

Figure 51. FC ENOL adapter

Specifications

Item Description

Adapter FRU number

00E3501 (Designed to comply with RoHS requirement)

Low-profile bracket part number 00ND496

Wrap plug FRU number

12R9314 (for Fibre LC connector)

10N7405 (for RJ45 connector)

I/O bus architecture

PCIe2 x8

Slot requirement

For details about slot priorities and placement rules, see the PCI adapter placement topic collection for your system.

Cables

SR SFP+ Copper Twinax and Cat5 Ethernet cables

Voltage

3.3 V, 12 V

Form factor

Short, low-profile

Maximum number

For the maximum adapters supported, see the PCI adapter placement topic collection for your system.

Operating system or partition requirements

If you are installing a new feature, ensure that you have the software that is required to support the new feature and that you determine whether there are any prerequisites for this feature and attaching devices. To check for the prerequisites, see IBM Prerequisite website (www-912.ibm.com/e_dir/eServerPrereq.nsf).

The adapter is supported on the following versions of the operating systems:

- AIX
 - AIX 7.1, or later
 - AIX 6.1, or later
- Linux
 - SUSE Linux Enterprise Server Version 11 Service Pack 3, or later
 - Red Hat Enterprise Linux Version 6.5, or later
 - For support details, see the Linux Alert website (www14.software.ibm.com/webapp/set2/sas/f/lopdiags/info/LinuxAlerts.htm)
- IBM i
 - IBM i Version 7.1, or later , supported through VIOS 2.2.2, or later

PCIe2 LP 2-Port 10 GbE RoCE SR Adapter (FC EC29; CCIN EC29)

Learn about the specifications and operating system requirements for the feature code (FC) EC29 adapter.

Overview

The FC EC29 and FC EC30 are the same adapter. FC EC29 is a low-profile adapter, and FC EC30 is a full-height adapter. The names of these two adapters are:

- FC EC29: PCIe2 LP 2-Port 10 GbE RoCE SR adapter
- FC EC30: PCIe2 2-Port 10 GbE RoCE SR adapter

The adapter is a PCIe generation-2 (PCIe2), dual port, 10 Gigabit Ethernet (GbE) adapter with a PCIe 2.0 host bus interface. The adapter supports the InfiniBand trade association (IBTA) standard for remote direct memory access (RDMA) over converged Ethernet (RoCE). The adapter supports short range (SR) optical connectivity. The adapter delivers high-bandwidth and low-latency 10 GbE connectivity. The adapter is optimized for high-transaction databases, cloud computing, virtualization, storage, and other data center applications. The adapter improves network performance by increasing available bandwidth to the processor and providing enhanced performance. The adapter minimizes processor usage by efficiently using memory access.

The adapter has a preinstalled optical transceiver. Little connector (LC) type connectors connect the adapter to standard 10-Gb SR optical cabling and provide up to 300 m (984.25 ft) cable length. The two transceiver ports are used for connectivity with other servers or switches in the network. Each port provides Ethernet connectivity with a nominal data rate of 10 gigabits per second (Gbps). The link aggregation and failover features of the adapter are ideal for critical network applications that require redundancy and high availability.

For details about slot priorities and placement rules, see the PCI adapter placement topic collection for your system.

Specifications

Item	Description
Adapter FRU number	00E1600 (Designed to comply with RoHS requirement)

I/O bus architecture

PCIe2 x8

Slot requirement

For the slot priorities, see the PCI adapter placement topic collection for your system.

Cables

Supports standard 10-Gb SR optical cabling and up to 300 m (984.25 ft) cable length.

Voltage

3.3 V

Form factor

Short

Maximum number

For the maximum adapters supported, see the PCI adapter placement topic collection for your system.

Limitations

This adapter cannot be used to boot an LPAR via AIX NIM or Linux Network Install. Systems that require installation from a network source must be configured with another Ethernet adapter that supports boot capability.

Operating system or partition requirements

This adapter is supported for the following versions of the operating system:

- AIX:
 - AIX Version 7.1, or later
 - AIX Version 6.1, or later
- Linux:
 - Red Hat Enterprise Linux Version 6.3 for POWER, or later, with current maintenance updates available from Red Hat.
 - SUSE Linux Enterprise Server 11 Service Pack 2, or later, with current maintenance updates available from SuSE.
- Firmware level 7.6, or later.

Related tasks:

[Installing PCI adapters](#)

Related reference:

[IBM Prerequisite website](#)

[Parts information](#)

[PCI adapter placement](#)

“Backplane daughter cards and RAID enablement cards” on page 2

Find links to topics that cover Backplane daughter cards and RAID enablement cards.

PCIe LP 2-Port 10 GbE SFN6122F Adapter (FC EC2G; CCIN EC2G)

Learn about the specifications and operating system requirements for the feature code (FC) EC2G adapters.

Overview

The FC EC2G PCIe LP 2-Port 10 GbE SFN6122F adapter is a low-profile adapter equivalent to the FC EC2J, which is a regular-height adapter.

The adapter is a PCIe generation-2 (PCIe2), dual-port, 10-Gigabit Ethernet (GbE) adapter with a PCIe 2.0 host bus interface. The adapter delivers high-bandwidth and low-latency 10 GbE connectivity. The adapter is optimized for high-transaction databases, cloud computing, virtualization, storage, and other

data center applications. The adapter improves network performance by instantiating protected virtual network interface controller (vNIC) interfaces for each running guest operating system or application, which gives it a direct pipeline to the Ethernet network. This architecture provides the most efficient way to maximize network and processor efficiency. The adapter supports Solarflare OpenOnload (<http://support.solarflare.com/oem/ibmpower>) for environments that require high performance and low latency. You can download the Solarflare NET drivers that support this adapter, from the Solarflare Support Site (<http://support.solarflare.com/oem/ibmpower>).

The two 10 Gb small form-factor pluggable (SFP+) transceiver ports are used for connectivity with other servers or switches in the network. Each SFP+ port provides Ethernet connectivity with a nominal data rate of 10 gigabits per second (Gbps), and uses the SFP+ copper twinaxial cables up to 5 m (16.4 ft) in length.

For details about slot priorities and placement rules, see the PCI adapter placement topic collection for your system.

Figure 52 shows the adapter.

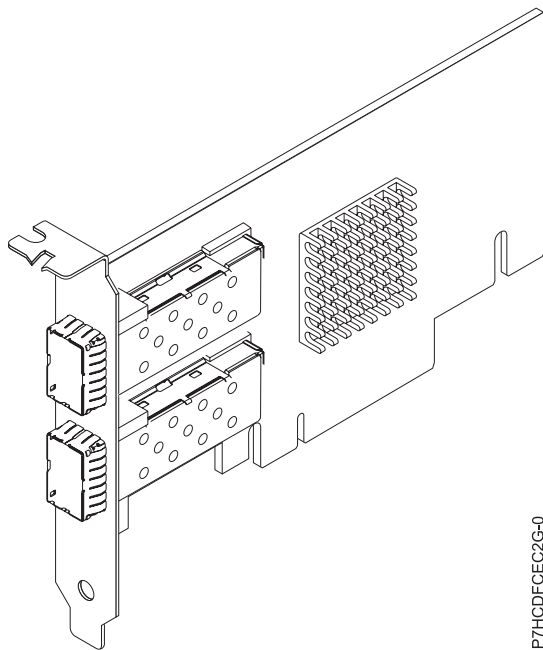

Figure 52. FC EC2G adapter

Specifications

Item Description

Adapter FRU number

00E8224 (Designed to comply with RoHS requirement)

I/O bus architecture

PCIe2 x8

Slot requirement

For the slot priorities, see the PCI adapter placement topic collection for your system.

Cables

For details, see “Cables” on page 159.

Voltage

3.3 V

Form factor

Short

Maximum number

For the maximum adapters supported, see the PCI adapter placement topic collection for your system.

Operating system or partition requirements

This adapter is supported for the following version of the operating system:

- Red Hat Enterprise Linux Version 6.4 for POWER, or later, with current maintenance updates available from Red Hat.

Note: OpenOnload and performance optimized drivers are available for download directly from the Solarflare Support Site (<http://support.solarflare.com/oem/ibmpower>).

Cables

FC EC2G requires the use of compatible SFP+, 10 Gbps, copper, twinaxial, active Ethernet cables. For a view of the cable top and cable bottom, see Figure 53. These cables are compliant with industry standard specifications SFF-8431 Rev 4.1 and SFF-8472 Rev 10.4, and all applicable IBM requirements.

Note: These cables are EMC Class A compliant.

For details about the cable feature codes, see Table 48.

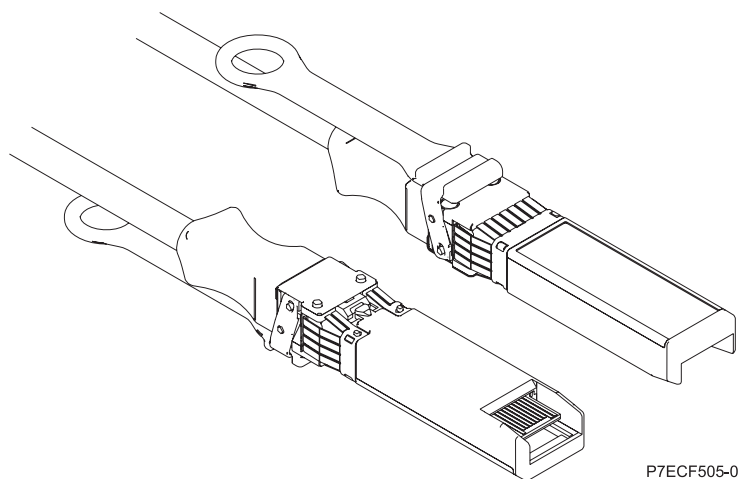

Figure 53. Top and bottom views of the cable

Table 48. FC and part number for varying lengths of the cable

Cable length	1 m (3.28 ft)	3 m (9.84 ft)	5 m (16.4 ft)
FC	EN01	EN02	EN03
CCIN	EF01	EF02	EF03
Part number	46K6182	46K6183	46K6184

Related tasks:

[Installing PCI adapters](#)

Related reference:

[↗ IBM Prerequisite website](#)

[↗ Parts information](#)

[↗ PCI adapter placement](#)

“Backplane daughter cards and RAID enablement cards” on page 2

Find links to topics that cover Backplane daughter cards and RAID enablement cards.

PCIe 2-Port LP 10 GbE SFN5162F Adapter (FC EC2H; CCIN EC2H)

Learn about the specifications and operating system requirements for the feature code (FC) EC2H adapters.

Overview

The FC EC2H PCIe 2-Port LP 10 GbE SFN5162F adapter is a low-profile adapter equivalent to the FC EC2K, which is a regular-height adapter.

The adapter is a PCIe generation-2 (PCIe2), dual-port, 10-Gigabit Ethernet (GbE) adapter with a PCIe 2.0 host bus interface. The adapter delivers high-bandwidth and low-latency 10 GbE connectivity. The adapter is optimized for high-transaction databases, cloud computing, virtualization, storage, and other data center applications. The adapter improves network performance by instantiating protected virtual network interface controller (vNIC) interfaces for each running guest operating system or application, which gives it a direct pipeline to the Ethernet network. This architecture provides the most efficient way to maximize network and processor efficiency. You can download the Solarflare NET drivers that support this adapter, from the Solarflare Support Site (<http://support.solarflare.com/oem/ibmpower>).

The two 10 Gb small form-factor pluggable (SFP+) transceiver ports are used for connectivity with other servers or switches in the network. Each SFP+ port provides Ethernet connectivity with a nominal data rate of 10 gigabits per second (Gbps), and uses the SFP+ copper twinaxial cables up to 5 m (16.4 ft) in length.

For details about slot priorities and placement rules, see the PCI adapter placement topic collection for your system.

Figure 54 on page 161 shows the adapter.

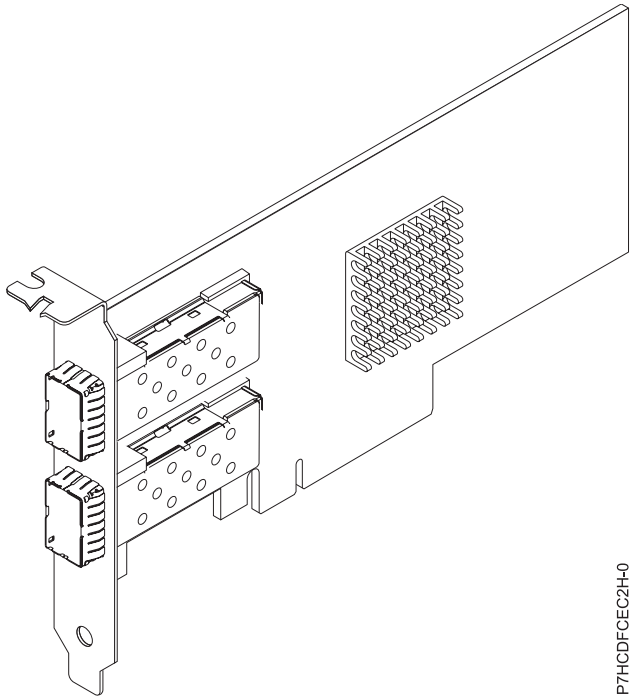

P7HCDFCEC2H-0

Figure 54. FC EC2H adapter

Specifications

Item Description

Adapter FRU number

00E8230 (Designed to comply with RoHS requirement)

I/O bus architecture

PCIe2 x8

Slot requirement

For the slot priorities, see the PCI adapter placement topic collection for your system.

Cables

For details, see “Cables” on page 162.

Voltage

3.3 V

Form factor

Short

Maximum number

For the maximum adapters supported, see the PCI adapter placement topic collection for your system.

Operating system or partition requirements

This adapter is supported for the following version of the operating system:

- Red Hat Enterprise Linux Version 6.4 for POWER, or later, with current maintenance updates available from Red Hat.

Note: OpenOnload and performance optimized drivers are available for download directly from the Solarflare Support Site (<http://support.solarflare.com/oem/ibmpower>).

Cables

FC EC2H requires the use of compatible SFP+, 10 Gbps, copper, twinaxial, active Ethernet cables. For a view of the cable top and cable bottom, see Figure 55. These cables are compliant with industry standard specifications SFF-8431 Rev 4.1 and SFF-8472 Rev 10.4, and all applicable IBM requirements.

Note: These cables are EMC Class A compliant.

For details about the cable feature codes, see Table 49.

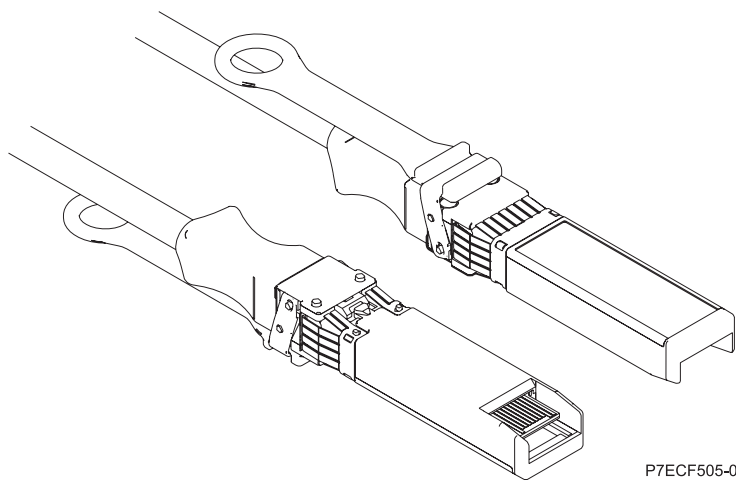

Figure 55. Top and bottom view of the cable

Table 49. Feature code and part number for varying lengths of the cable

Cable length	1 m (3.28 ft)	3 m (9.84 ft)	5 m (16.4 ft)
Feature code	EN01	EN02	EN03
CCIN	EF01	EF02	EF03
Part number	46K6182	46K6183	46K6184

Related tasks:

[Installing PCI adapters](#)

Related reference:

[IBM Prerequisite website](#)

[Parts information](#)

[PCI adapter placement](#)

“Backplane daughter cards and RAID enablement cards” on page 2

Find links to topics that cover Backplane daughter cards and RAID enablement cards.

4-Port USB PCI Express Adapter (FC 2728; CCIN 57D1)

Learn about the specifications for the feature code (FC) 2728 adapters.

The FC 2728 4-Port USB PCIe Adapter is a single-lane (1x) PCIe high-performance expansion adapter that provides the following features and support:

- Compliance with PCIe base specification revision 1.1
- Single-lane (1x) PCI Express for a throughput of 2.5 Gbps

- Single-slot, half-length PCIe card
- FCC Class A
- Four downstream, external, high-speed USB 2.0 ports ¹
- Data-transfer rates of 480 Mbps (high-speed), 12 Mbps (full-speed), and 1.5 Mbps (low-speed)
- Full compliance with Universal Serial Bus (USB) specifications, revision 1.1 and 2.0
- Simultaneous operation of multiple USB 2.0 and USB 1.1 devices
- Compliance with Enhanced Host Controller Interface (EHCI) and Open Host Controller Interface (OHCI) standards
- Integrated dual-speed USB transceivers
- A total of 126 USB hubs and devices are supported by the adapter ¹

¹ The four external ports are shared and controlled by three internal USB controllers. AIX might list only the three controllers; however, all four ports are operational.

The following figure shows the adapter.

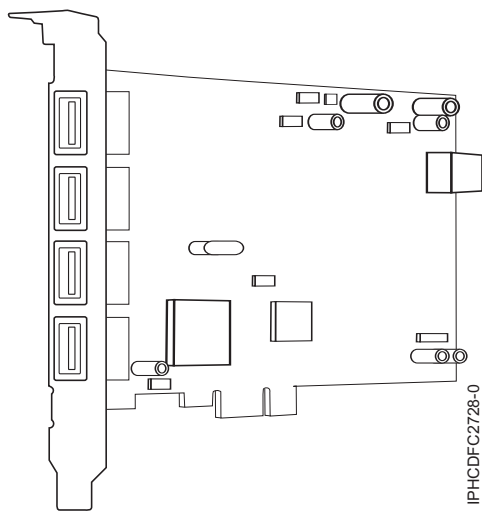

Figure 56. 4-Port USB PCIe Adapter

For details about slot priorities and placement rules, see the PCI adapter placement topic collection for your system.

Specifications

Item Description

FRU number

46K7494 (Designed to comply with RoHS requirement.)

Bus architecture

PCI 2.2 compliant

Busmaster

Yes

Card type

Full size

Maximum number and adapter slots

For the maximum adapters supported, see the PCI adapter placement topic collection for your system.

Connector

Standard USB single pin-type series "A" receptacle

Wrap plug

None

Cables

None

Operating system or partition requirements

This adapter is supported for the following versions of the operating systems:

- AIX
 - AIX 7.1
 - AIX 6.1
 - AIX 5.3 for POWER
- Linux
 - Red Hat Enterprise Linux
 - SUSE Linux Enterprise Server

If you are installing a new feature, ensure that you have the software that is required to support the new feature and that you determine whether there are any prerequisites for this feature and attaching devices. To check for the prerequisites, see IBM Prerequisite website (www-912.ibm.com/e_dir/eServerPrereq.nsf).

Related tasks:

[Installing PCI adapters](#)

Related reference:

[IBM Prerequisite website](#)

[Parts information](#)

[PCI adapter placement](#)

“Backplane daughter cards and RAID enablement cards” on page 2

Find links to topics that cover Backplane daughter cards and RAID enablement cards.

PCIe Cryptographic Coprocessor (FC 4807, FC 4808, and FC 4809; CCIN 4765)

Learn about the specifications for the PCIe Cryptographic Coprocessor.

The PCIe Cryptographic Coprocessor adapters (feature codes (FC) 4807, FC 4808, and FC 4809) provide the secure-key cryptographic accelerator and the Cryptographic Coprocessor functions in a single PCIe card. The coprocessor functions are targeted to banking and finance applications. The financial personal identification number (PIN) processing and Euro pay, Mastercard, Visa (EMV) credit card functions are provided. EMV is a standard for the integrated-chip based credit cards. The secure-key accelerator functions are targeted to improving the performance of Secure Sockets Layer (SSL) transactions. The (FC 4807, FC 4808, and FC 4809) provide the security and performance required to support emerging digital signature applications. The host application access to the cryptographic services of the (FC 4807, FC 4808, and FC 4809) are by the Common Cryptographic Architecture (CCA) application programming interfaces (APIs) and by the Public-Key Cryptographic Standards (PKCS11). The (FC 4807, FC 4808, and FC 4809) provide secure storage of cryptographic keys in a tamper-resistant hardware security module, which is designed to meet FIPS PUB 140-2 on security requirements.

The FC 4807, FC 4808, and FC 4809 are the same adapter but the different FCs indicate if a blind-swap cassette is used and the type of the cassette.

- FC 4807 is not a blind-swap cassette
- FC 4808 is a generation-3 blind-swap cassette
- FC 4809 is a generation-4 blind-swap cassette

IBM PCIe Cryptographic adapter highlights:

- PCIe 4x standard height - half length
- Integrated Dual PPC processors
- ASIC (Accelerator engines)
- Supports the Common Cryptographic Architecture (CCA) application programming interfaces (APIs) and the Public-Key Cryptographic Standards (PKCS11) on the single firmware load.
- 3072, 4096 bit RSA CRT HW (including routing)
- SHA 256 required HW or firmware within secure module (including routing)
- Secure Key AES 128, 192, 256 bit keys
- Fast path – symmetric and asymmetric (secure and clear key)

For details about slot priorities and placement rules, see the PCI adapter placement topic collection for your system.

Supported operating systems

The following versions of the operating systems are supported:

- AIX
 - AIX 5.3 with the 5300-12 Technology Level, or later.
 - AIX 6.1 with the 6100-05 Technology Level, or later.
- IBM i
 - IBM i 7.1, or later.
 - IBM i 6.1 with 6.1.1 machine code or later.

Specifications and requirements

FRU number:

45D7948

RoHS compliant with server exemption

Placement information

To view information about the PCI adapter placement rules, see the PCI adapter placement topic collection for your system.

I/O bus architecture

PCI Express v1.1a

Storage

Shipping and storage temperature below $-35^{\circ}\text{C} \pm 60^{\circ}\text{C}$ ($-31^{\circ}\text{F} \pm 140^{\circ}\text{F}$) or above $1^{\circ}\text{C} \pm 60^{\circ}\text{C}$ ($33.8^{\circ}\text{F} \pm 140^{\circ}\text{F}$) limits.

Operation (ambient in system)

This component collects and controls all the sensors to prevent the physical penetration and any abnormal environmental condition within its wide operational range of $10^{\circ}\text{C} \pm 35^{\circ}\text{C}$ ($50^{\circ}\text{F} \pm 95^{\circ}\text{F}$).

Tamper protection range

Outside of the tamper protection range limits of $-38^{\circ}\text{C} \pm 3^{\circ}\text{C}$ (-41.8°F to -31°F) to $+90^{\circ}\text{C} \pm 2^{\circ}\text{C}$ (190.4°F to 197.6°F), the card will be permanently disable.

Handling requirements

Each PCIe Cryptographic Coprocessor includes a certified device key. This electronic key, which is stored in the adapter's battery-powered and protected memory, digitally signs status messages to confirm that the PCI Cryptographic Coprocessor is genuine and that no tampering has occurred.

If any of the secure module's tamper sensors are triggered by tampering or by accident, the PCIe Cryptographic Coprocessor erases all data in the protected memory, including the certified device key. Incorrect removal of the batteries triggers the tamper sensors and destroys the certified device keys. The PCI Cryptographic Coprocessor cannot operate without the certified device keys. To protect the keys, follow the guidelines given in the documentation provided with the coprocessor.

Attention: The batteries keep the coprocessor powered on even when it is not installed in a system. When handling, installing, or removing the adapter, do not let the adapter circuits come in contact with any conductive surface or tools. Doing so can render the adapter permanently inoperable.

Do not remove the batteries of the adapter. Data in the protected memory is lost when battery power is removed. For information about replacing the batteries, see the Installation Manual at the IBM Cryptocard website at <http://www-03.ibm.com/security/cryptocards/>.

Attention: While installing the coprocessor, observe the following precautions:

- The coprocessor is always powered by the batteries, even when it is not installed in the system.
- The battery power is necessary to keep the coprocessor operational.
- The loss of battery power or a voltage drop triggers a tamper event and permanently renders the coprocessor inoperable.
- Any short on the battery power distribution circuits causes a voltage drop and a tamper event.
- Do not lay the coprocessor on or cause the coprocessor to come in contact with any conductive surface.
- Do not strike the coprocessor circuits with metal or conductive tools.
- Use static-protective measures at all times when handling the coprocessor.

Related tasks:

[🔗 Installing PCI adapters](#)

Related reference:

[🔗 IBM Prerequisite website](#)

[🔗 Parts information](#)

[🔗 PCI adapter placement](#)

“Backplane daughter cards and RAID enablement cards” on page 2

Find links to topics that cover Backplane daughter cards and RAID enablement cards.

PCIe2 2-port 4X InfiniBand QDR Adapter (FC 5283, FC 5285; CCIN 58E2)

Learn about the specifications and operating system requirements for the feature code (FC) 5283 and FC 5285 adapters.

Overview

The PCIe2 2-port 4X IB QDR Adapters are generation-2 4X InfiniBand QDR adapters that provides high speed connectivity with other servers or InfiniBand switches.

The names for these adapters are:

- FC 5283: PCIe2 LP 2-port 4X InfiniBand QDR Adapter
- FC 5285: PCIe2 2-port 4X InfiniBand QDR Adapter

Each port has a maximum of 40 Gb allotted to it.

The FC 5283 is a low-profile adapter and requires an available generation-2 low-profile slot in FC 5685 (PCIe Riser Card (Generation-2)). FC 5285 has a high-profile tailstock and requires a full-height generation-2 slot.

For details about slot priorities and placement rules, see the PCI adapter placement topic collection for your system.

Specifications

Item Description

Adapter FRU number

74Y2987 (Designed to comply with RoHS requirement)

I/O bus architecture

PCIe x8

Slot requirement

Requires an available slot in FC 5685

Cables

No cables required.

Voltage

3.3 V

Form factor

Short

Maximum number

For the maximum adapters supported, see the PCI adapter placement topic collection for your system.

Operating system or partition requirements

This adapter is supported for the following versions of the operating systems:

- AIX:
 - AIX 7.1 with Service Pack 3, or later.
 - AIX 6.1 with the 6100-06 Technology Level, and Service Pack 5 or later.
 - AIX 6.1 with the 6100-05 Technology Level, and Service Pack 6 or later.
- Linux:
 - SUSE Linux Enterprise Server 10, Service Pack 3, or later
 - SUSE Linux Enterprise Server 11, Service Pack 1, or later
 - Red Hat Enterprise Linux, Version 5.6, or later
 - Red Hat Enterprise Linux, Version 6, or later

Related tasks:

[Installing PCI adapters](#)

Related reference:

[IBM Prerequisite website](#)

[Parts information](#)

[PCI adapter placement](#)

“Backplane daughter cards and RAID enablement cards” on page 2

Find links to topics that cover Backplane daughter cards and RAID enablement cards.

PCIe RAID and SSD SAS adapter 3 Gb (FC 2053, FC 2055; CCIN 57CD)

Learn about the specifications and operating system requirements for the feature code (FC) 2053 or 2055 adapter.

Overview

The PCIe-based solid-state drive (SSD) offering consists of a SAS PCIe adapter and an SSD module. The RAID and SSD SAS adapter is a double-wide, low-profile, short, PCIe x8 adapter that requires two adjacent PCIe slots. You can plug one, two, or four SSD modules directly onto the adapter and avoid the use of any SFF, 3.5 inch SAS bays, or any cabling to the SAS disk enclosures.

Though it is physically the same PCIe adapter, there are two feature codes (FC):

- PCIe RAID and SSD SAS Adapter 3 Gb (FC 2053) designates a low-profile PCIe adapter to be used in the Power 710 Express, Power 720 Express, Power 730 Express, and Power 740 Express low-profile slots.
- PCIe RAID and SSD SAS Adapter 3 Gb with Blind Swap Cassette (FC 2055) designates that the PCIe adapter is in a double-wide blind swap cassette for use in a 12X-attached 5802 and 5877 PCIe I/O drawer.

Though it is physically the same SSD module, two feature codes are used to describe the different operating system environments. The following are the two codes that enable the IBM configurator tools to track the different SSD protection rules that are associated with the AIX, IBM i, and Linux operating systems:

- 177 GB SSD Module with enterprise multi-level cell (EMLC) (AIX or Linux) is FC 1995
- 177 GB SSD Module with EMLC (IBM i) is FC 1996

There are multiple configuration options that provide SSD protection and redundancy. If you want redundancy at an adapter level, you can mirror the SSD module of one PCIe RAID and SSD SAS Adapter against the SSD module of another PCIe RAID and SSD SAS Adapter by using the IBM AIX, IBM i, or Linux operating system. This configuration is suggested because there is no write cache in the PCIe RAID and SSD SAS Adapter. However, the RAID 5 or RAID 6 can also be used. If you want RAID 0, you must mirror the SSD module through the operating system. Ensure that if an SSD module requires to be replaced or moved, the PCIe RAID and SSD SAS Adapter on which the SSD module is located must be removed from the server or I/O drawer before the SSD module can be accessed. This action is different from the existing 69 GB SSD configurations, which can use the SAS bay hot-plug capability to remove and replace a single SSD module without removing the associated PCI SAS adapter.

For the AIX and Linux operating systems, if you do not want to have PCIe RAID and SSD SAS Adapter redundancy, but still want to protect the SSD module content, the PCIe RAID and SSD SAS Adapter can provide RAID 5 or RAID-6 level protection on the PCIe adapter. RAID 10 is not supported for the PCIe RAID and SSD SAS adapter. Hot-spare capability can optionally be used with RAID 5 but the spare SSD module must be on that same PCIe RAID and SSD SAS adapter.

The following figure shows the adapter.

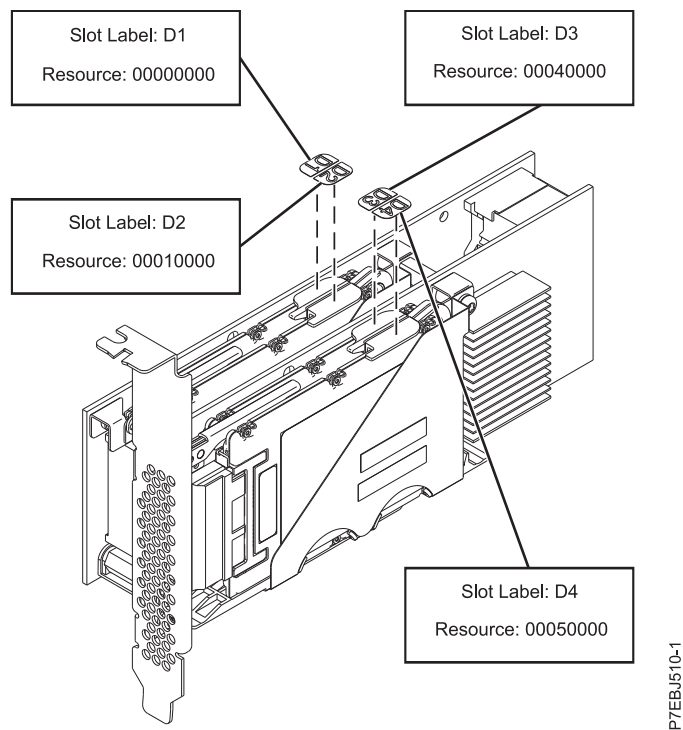

Figure 57. PCIe Dual - x4 3 Gb SAS RAID Adapter

For details about slot priorities and placement rules, see the PCI adapter placement topic collection for your system.

Specifications

Item Description

Adapter FRU number

Low-profile FRU 74Y6406

Full height FRU 74Y6409

(Designed to comply with RoHS requirement.)

SSD Module (CCIN 58B2) FRU number

1.8 inch 177 GB small form factor solid-state drive on PCIe SAS RAID and SSD adapter.

FRU 43W7749

I/O bus architecture

PCIe x8

Slot requirement

Two PCIe x8 slots per adapter. (The adapter physically plugs into one slot and covers the adjacent slot to the left.)

Cables

No cables are required.

Voltage

3.3 V

Form factor

Short

Maximum number

For the maximum adapters supported, see the PCI adapter placement topic collection for your system.

Attributes

- The PCIe adapters and their associated SSD modules are supported in the IBM Power 710 Express, IBM Power 720 Express, IBM Power 730 Express, IBM Power 740 Express, and IBM Power 750 Express system units or in the feature 5802 and 5877 12X PCIe I/O drawers when attached to the IBM Power 720 Express, IBM Power 740 Express, IBM Power 750 Express, IBM Power 770, and IBM Power 780.
- The adapter is not supported in the IBM Power 770 and IBM Power 780 system units. It is not supported in the 12X-attached feature 5803 and 5873 PCIe I/O drawers. It is not supported on POWER6® servers.
- Each RAID formatted (528-byte blocks) SSD module provides up to 177 GB of capacity in the IBM AIX, IBM i, or Linux environment. Modules can also be formatted as a JBOD (512 byte blocks) and provide up to 200 GB of capacity in an AIX and Linux environment. Formatting for RAID provides additional data integrity and the option to use RAID 0 (when SSD modules are mirrored at the operating system level), RAID 5, or RAID 6.

Operating system or partition requirements

This adapter is supported for the following versions of the operating systems:

- AIX
 - AIX Version 7.1
 - AIX Version 6.1 with the 6100-06 Technology Level
 - AIX Version 6.1 with the 6100-03 Technology Level and Service Pack 7
 - AIX Version 6.1 with the 6100-04 Technology Level and Service Pack 7
 - AIX Version 6.1 with the 6100-05 Technology Level and Service Pack 3
 - AIX for POWER Version 5.3 with the 5300-10 Technology Level and Service Pack 5
 - AIX for POWER Version 5.3 with the 5300-11 Technology Level and Service Pack 5
 - AIX for POWER Version 5.3 with the 5300-12 Technology Level and Service Pack 2
- Linux
 - Red Hat Enterprise Linux Version 5, with update 5, or later
 - SUSE Linux Enterprise Server 10, with Service Pack 3, or later
 - SUSE Linux Enterprise Server 11, with Service Pack 1, or later
- IBM i
 - IBM i Version 7.1
 - IBM i Version 6.1, or later
- VIOS
 - VIOS Version 2.2, or later

This adapter requires the following drivers:

- AIX: devices.pciex.14103903 device driver package
- Linux:
 - iprutils version 2.2.21 and ipr driver version 2.2.0.3 (or newer) for RHEL5 kernels
 - iprutils version 2.2.21 and ipr driver version 2.2.0.3 (or newer) for SLES10 kernels
 - iprutils version 2.2.21 and ipr driver version 2.4.3 (or newer) for SLES11 kernels

If you are installing a new feature, ensure that you have the software that is required to support the new feature and that you determine whether there are any prerequisites for this feature and attaching devices. To check for the prerequisites, see IBM Prerequisite website (www-912.ibm.com/e_dir/eServerPrereq.nsf).

Cables

None

Related tasks:

Serial-attached SCSI cable planning

Learn about how to install the SAS cables to the hard disk drives or solid-state drives.

[🔗 Installing PCI adapters](#)

Related reference:

“Important partitioning considerations with dual-slot and multi-adapter configurations” on page 4
Learn about partitioning considerations with dual-slot and multi-adapter configurations.

[🔗 IBM Prerequisite website](#)

[🔗 Parts information](#)

[🔗 PCI adapter placement](#)

“Backplane daughter cards and RAID enablement cards” on page 2

Find links to topics that cover Backplane daughter cards and RAID enablement cards.

Related information:

[🔗 Logical partitioning](#)

Information about logical partitioning.

[🔗 Changing partition profile properties](#)

Information about changing partition profile properties by using the HMC.

Dual IOA Enablement Card (FC 5662)

Information about the specifications for the Dual IOA Enablement Card.

SAS RAID controllers for AIX

Information about usage and maintenance information for the SAS RAID Controller for the AIX.

SAS RAID controllers for IBM i

Information about usage and maintenance information for the SAS RAID Controller for the IBM i.

SAS RAID controllers for Linux

Information about the usage and maintenance information for the SAS RAID Controller for Linux.

PCIe LP Dual - x4 SAS Adapter (FC 5278; CCIN 57B3)

Learn about the specifications and operating system requirements for the feature code (FC) 5278 adapter.

Overview

The FC 5278 (PCIe LP Dual - x4 SAS adapter) is the low-profile adapter same as the FC 5901, which is the full-height adapter. The names of the two adapters are:

- FC 5278: PCIe LP Dual - x4 SAS adapter
- FC 5901: PCIe Dual - x4 SAS adapter

The PCIe LP Dual - x4 SAS adapter is a low-profile, short form factor adapter for high-performance and high-density, serial attached SCSI (SAS) applications. It supports the attachment of SAS disk, tape, and DVD by using a pair of mini SAS 4x connectors which allow the eight physical links to be used in various narrow and wide-port configurations. The adapter does not have write cache.

The adapter is a 64 bit, 3.3 V, bootable SAS adapter that provides RAID 0, 5, 6, and 10 capability. Some RAID level support is operating system dependent. The adapter provides RAID 0, RAID 5, RAID 6, and RAID 10 for the AIX and Linux operating systems. IBM i operating system provides mirroring and data spreading capability. FC 5901 does not support the RAID 5 and RAID 6 configurations. The adapter does

not have write cache. (The write performance of RAID 5 and RAID 6 can be poor on adapters that do not provide write cache. Consider using an adapter which provides write cache when using RAID 5 or RAID 6.)

The adapter can address up to 48 SAS disk drives, although the actual number of drives in a system is subject to the physical placement limitations of the system. Externally attached devices are designed to run at a data rate of 1.5 Gbps for serial ATA (SATA) devices, and 3 Gbps for SAS devices. This card supports RAID and non-RAID DASD, tape, and optical devices. This adapter supports the multi-initiator and high availability configurations in AIX and Linux. IBM i does not support feature 5901 in multi-initiator and high availability configurations.

Important: See the SAS RAID controllers for AIX, SAS RAID controllers for Linux, or SAS RAID controllers for IBM i topics for more information and important considerations for multi-initiator and high availability or dual storage IOA configurations

The FC 5278 supports SAS SFF disk drives located in a PCIe 12X I/O Drawer or SAS disk drives located in an EXP 12S Disk Drawer or SAS disk drives located in a supported POWER system unit (split disk backplane).

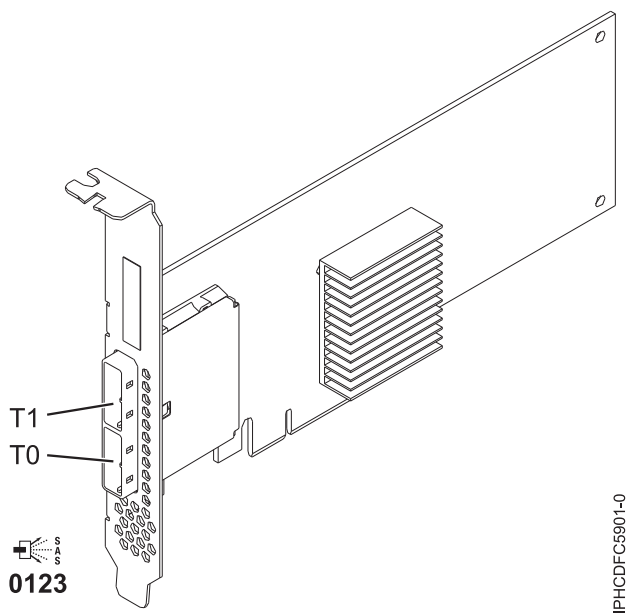

Figure 58. PCIe Dual - x4 SAS adapter

Specifications

Item Description

Adapter FRU number

44V4852 (Designed to comply with RoHS requirement)

I/O bus architecture

PCIe

Slot requirement

One available PCIe x8 slot

Cables

SAS device attachment requires specific cables that are provided with the subsystem or device features being attached. Special cabling is required for multi-initiator and high availability configurations. See Serial attached SCSI cable planning.

Voltage

3.3 V

Form factor

Short, low-profile

Maximum number

For the maximum adapters supported, see the PCI adapter placement topic collection for your system.

Attributes

- Two external mini SAS 4x connectors provide attachment of SAS and Serial Advanced Technology Attachment (SATA) device enclosures
- SAS Serial SCSI Protocol (SSP), Serial ATA Tunneling Protocol (STP), and Serial Management Protocol (SMP)
- RAID 0, 5, 6, 10

The write performance of RAID 5 and RAID 6 can be poor on adapters that do not provide write cache. Consider using an adapter that provides write cache when using RAID 5 or RAID 6.

- Concurrent firmware update
- Removable media device supported (Removable media is not supported in multi-initiator and high availability configurations)
- Removable media device supported
- 440 - 500 Mhz PowerPC® (PPC)
- Support for multi-initiator and high availability configurations

For details about slot priorities and placement rules, see the PCI adapter placement topic collection for your system.

Operating system or partition requirements

If you are installing a new feature, ensure that you have the software that is required to support the new feature and that you determine whether there are any prerequisites for this feature and attaching devices. To check for the prerequisites, see IBM Prerequisite website (www-912.ibm.com/e_dir/eServerPrereq.nsf).

The adapter is supported on the following versions of the operating systems:

- AIX
 - AIX Version 7.1, or later.
 - AIX Version 6.1, or later.
 - AIX Version 5.3, or later.
- Linux
 - Red Hat Enterprise Linux 5.6 for POWER, or later.
 - Novel SUSE Linux Enterprise Server 11 Service Pack 1, or later.
- IBM i
 - IBM i 7.1, or later.
 - IBM i 6.1, or later.

This adapter requires the following device drivers:

- AIX: devices.pci.1410bd02 device driver package
- Linux:
 - iprutils version 2.4.1 and ipr driver version 2.0.11.6 (or newer) for RHEL4 kernels
 - iprutils version 2.4.1 and ipr driver version 2.2.0.2 (or newer) for RHEL5 kernels
 - iprutils version 2.4.1 and ipr driver version 2.2.0.2 (or newer) for SLES10 kernels

Related tasks:

[🔗 Installing PCI adapters](#)

Related reference:

[🔗 IBM Prerequisite website](#)

[🔗 Parts information](#)

[🔗 PCI adapter placement](#)

“Backplane daughter cards and RAID enablement cards” on page 2

Find links to topics that cover Backplane daughter cards and RAID enablement cards.

PCIe Dual - x4 3 Gb SAS RAID Adapter (FC 5903 and FC 5805; CCIN 574E)

Learn about the specifications and operating system requirements for the feature code (FC) 5903 and FC 5805 adapters.

Overview

The PCI Express (PCIe) Dual - x4 3 Gb SAS RAID Adapter supports the attachment of Serial attached SCSI (SAS) disk and SAS solid-state drives using a pair of mini SAS 4x connectors. The 5903 or 5805 has a 380 MB write cache and a concurrently replaceable cache battery pack. The adapter must always be installed in pairs and is always to be used in a high availability, multi-initiator RAID configuration using two adapters in dual-controller mode. Two 5903 or 5805 adapters provide mirrored write-cache data and mirrored RAID parity footprints between the adapters. If the 5903 or 5805 pairing is broken, then write cache is disabled.

Important: See the SAS RAID controllers for AIX, SAS RAID controllers for Linux, or SAS RAID controllers for IBM i topics for more information and important considerations for multi-initiator and high availability or dual storage IOA configurations

The 5903 or 5805 supports SAS small form factor (SFF) disk drives located in a PCIe 12X I/O Drawer or SAS disk drives located in an EXP 12S Disk Drawer. It can also be connected to the internal disk drives in the system unit using the appropriate split disk backplane feature and cabling.

The adapter is a 3.3 V, PCI-e x8 bootable SAS adapter that provides RAID 0, RAID 5, RAID 6, and RAID 10 for the AIX and Linux operating systems. Under the IBM i operating system, mirroring and data spreading are provided by the operating system, and RAID 5 and RAID 6 are provided by the adapter.

With adequate cabling and configuration, multiple wide ports are used to provide redundant paths to each dual port SAS drive or solid-state drive. The adapter manages SAS path redundancy and path switching in case a SAS failure occur.

The 5903 or 5805 contains a LED ((C) in Figure 59 on page 175) that flashes if the cache data is present. The cache-data present LED flashes when there is possible data in the cache on the adapter. If the cache data present LED is flashing, do not replace the cache battery pack. If replaced when the LED is flashing, the cache data is lost. See Figure 59 on page 175 to locate the cache-data present LED on this adapter.

Attention: Do not attempt to replace the cache battery pack if the cache-data present LED on the card is flashing. The cache-data present LED indicates that there is possible data in the cache on the adapter. To prevent data loss, first make sure that the system has been shut down correctly. If the cache-data present LED is flashing, refer to one of the following topics before removing the cache battery pack.

- For Linux operating systems, see *Displaying rechargeable battery information*.
- For AIX operating systems, see *Displaying rechargeable battery information*.
- For IBM i operating systems, see *Displaying rechargeable battery information*.

Note: When configuring a raid array using the IBM toolkit and the FC5903 adapter for a system running Linux, the list of supported Direct Attach Storage Devices (DASD) is visible in the HMC only if you select the LVM configure option in the IBM toolkit.

The following figure shows the adapter.

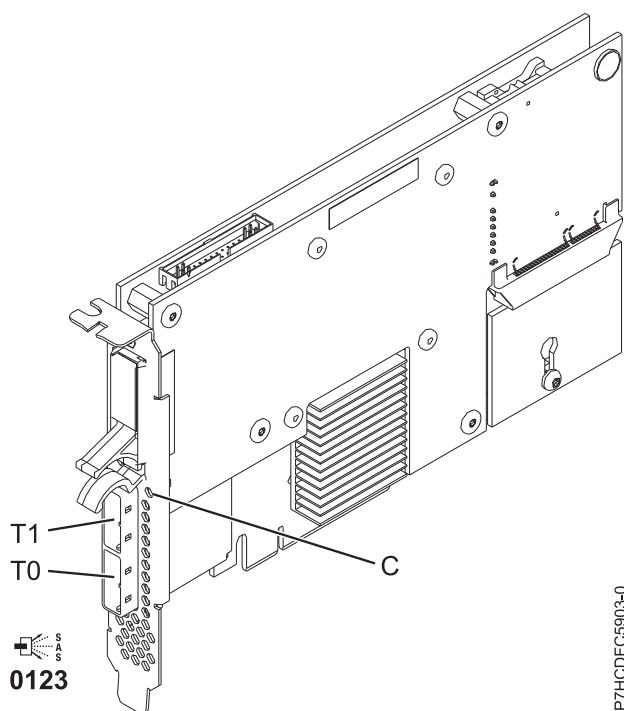

Figure 59. PCIe Dual - x4 3 Gb SAS RAID Adapter

Specifications

Item	Description
Adapter FRU number	46K4735 (Designed to comply with RoHS requirement.)
Battery FRU number	44V7597 (Designed to comply with RoHS requirement.)
I/O bus architecture	PCIe x8
Slot requirement	One PCIe x8 slot per adapter. Adapters are installed in pairs.

Adapter pairs do not require to be in the same enclosure. For higher availability, place adapters in separate enclosures. See the PCI adapter placement for placement rules.

Cables

When you attach 5886 EXP 12S Disk Drawer, at least one of the following SAS (X) cables must be used: 3661, 3662 or 3663.

SAS device attachment requires specific cables that are provided with the subsystem or device features being attached. Special cabling is required for multi-initiator and high availability configurations. See Serial attached SCSI cable planning.

Voltage

3.3 V

Form factor

Short

Maximum number

For the maximum adapters supported, see the PCI adapter placement topic collection for your system.

Attributes

- 48 SAS disk drives supported when the adapter is configured with four 5886 EXP 12S Disk Drawers
- 42 SAS disk drives supported when the adapter is configured with a 19-inch PCIe 12X I/O Drawer and two 5886 EXP 12S Disk Drawers (18 SFF disk drives plus up to 24 SAS disk drives)
- SAS speed: 3 Gbps
- SAS Serial-SCSI Protocol (SSP) and Serial Management Protocol (SMP) are supported
- 380 MB of non-volatile fast write cache can increase disk subsystem performance
- Dual controller supports mirrored-write cache data and mirrored-RAID parity footprints
- Concurrent firmware update supported
- Eight physical links from two mini SAS 4x connectors are provided
- Concurrent replaceable cache battery pack
- Removable media devices are not supported

For details about slot priorities and placement rules, see the PCI adapter placement topic collection for your system.

Operating system or partition requirements

This adapter is supported for the following versions of the operating systems:

- AIX:
 - AIX 5L Version 5.3 with the 5300-07 Technology Level and Service Pack 8, or later
 - AIX 5L Version 5.3 with the 5300-08 Technology Level and Service Pack 6, or later
 - AIX Version 5.3 with the 5300-09 Technology Level and Service Pack 2, or later
 - AIX Version 5.3 with the 5300-10 Technology Level, or later
 - AIX 6.1 and Service Pack 8, or later
 - AIX Version 6.1 with the 6100-01 Technology Level and Service Pack 4, or later
 - AIX Version 6.1 with the 6100-02 Technology Level and Service Pack 3, or later
 - AIX Version 6.1 with the 6100-03 Technology Level, or later
- Linux:
 - Red Hat Enterprise Linux Version 4, with update 7, or later
 - Red Hat Enterprise Linux Version 5, with update 2, or later
 - SUSE Linux Enterprise Server 10, with service pack 2, or later
- IBM i
 - IBM i 6.1.1 and Resave A, or later, is required for Dual Storage IOA support.

If you are installing a new feature, ensure that you have the software that is required to support the new feature and that you determine whether there are any prerequisites for this feature and attaching devices.

To check for the prerequisites, see IBM Prerequisite website (www-912.ibm.com/e_dir/eServerPrereq.nsf).

Related tasks:

Serial-attached SCSI cable planning

Learn about how to install the SAS cables to the hard disk drives or solid-state drives.

[🔗 Installing PCI adapters](#)

Related reference:

“Important partitioning considerations with dual-slot and multi-adapter configurations” on page 4

Learn about partitioning considerations with dual-slot and multi-adapter configurations.

[🔗 IBM Prerequisite website](#)

[🔗 Parts information](#)

[🔗 PCI adapter placement](#)

“Backplane daughter cards and RAID enablement cards” on page 2

Find links to topics that cover Backplane daughter cards and RAID enablement cards.

Related information:

[🔗 Logical partitioning](#)

Information about logical partitioning.

[🔗 Changing partition profile properties](#)

Information about changing partition profile properties by using the HMC.

Dual IOA Enablement Card (FC 5662)

Information about the specifications for the Dual IOA Enablement Card.

SAS RAID controllers for AIX

Information about usage and maintenance information for the SAS RAID Controller for the AIX.

SAS RAID controllers for IBM i

Information about usage and maintenance information for the SAS RAID Controller for the IBM i.

SAS RAID controllers for Linux

Information about the usage and maintenance information for the SAS RAID Controller for Linux.

PCIe Dual - x4 SAS Adapter (FC 5901; CCIN 57B3)

Learn about the specifications and operating system requirements for the feature code (FC) 5901 adapter.

Overview

The PCI Express (PCIe) Dual - 4x SAS adapter is a low-profile short form factor adapter for high-performance and high-density, serial attached SCSI (SAS) applications. It supports the attachment of SAS disk, tape, and DVD by using a pair of mini SAS 4x connectors which allow the eight physical links to be used in various narrow and wide-port configurations. The adapter does not have write cache.

The adapter is a 64 bit, 3.3 V, bootable SAS adapter that provides RAID 0, 5, 6, and 10 capability. Some RAID level support is operating system dependent. The adapter provides RAID 0, RAID 5, RAID 6, and RAID 10 for the AIX and Linux operating systems. IBM i operating system provides mirroring and data spreading capability. FC 5901 does not support the RAID 5 and RAID 6 configurations. The adapter does not have write cache. (The write performance of RAID 5 and RAID 6 can be poor on adapters that do not provide write cache. Consider using an adapter which provides write cache when using RAID 5 or RAID 6.)

The adapter can address up to 48 SAS disk drives, although the actual number of drives in a system is subject to the physical placement limitations of the system. Externally attached devices are designed to run at a data rate of 1.5 Gbps for serial ATA (SATA) devices, and 3 Gbps for SAS devices. This card

supports RAID and non-RAID DASD, tape, and optical devices. This adapter supports the multi-initiator and high availability configurations in AIX and Linux. IBM i does not support feature 5901 in multi-initiator and high availability configurations.

Important: See the SAS RAID controllers for AIX, SAS RAID controllers for Linux, or SAS RAID controllers for IBM i topics for more information and important considerations for multi-initiator and high availability or dual storage IOA configurations

The 5901 supports SAS SFF disk drives located in a PCIe 12X I/O Drawer or SAS disk drives located in an EXP 12S Disk Drawer or SAS disk drives located in a supported POWER system unit (split disk backplane).

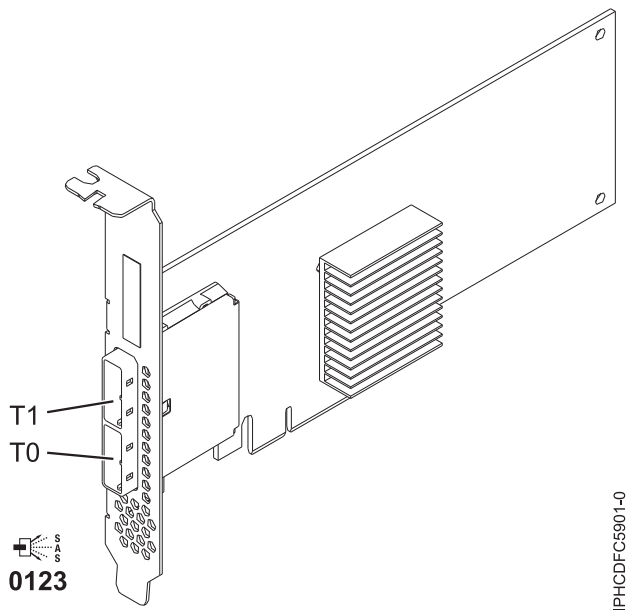

Figure 60. PCIe Dual - x4 SAS adapter

Specifications

Item Description

Adapter FRU number

44V4852 (Designed to comply with RoHS requirement)

I/O bus architecture

PCIe

Slot requirement

One available PCIe x8 slot

Cables

SAS device attachment requires specific cables that are provided with the subsystem or device features being attached. Special cabling is required for multi-initiator and high availability configurations. See Serial attached SCSI cable planning.

Voltage

3.3 V

Form factor

Short, low-profile

Maximum number

For the maximum adapters supported, see the PCI adapter placement topic collection for your system.

Attributes

- Two external mini SAS 4x connectors provide attachment of SAS and Serial Advanced Technology Attachment (SATA) device enclosures
- SAS Serial SCSI Protocol (SSP), Serial ATA Tunneling Protocol (STP), and Serial Management Protocol (SMP)
- RAID 0, 5, 6, 10

The write performance of RAID 5 and RAID 6 can be poor on adapters that do not provide write cache. Consider using an adapter that provides write cache when using RAID 5 or RAID 6.

- Concurrent firmware update
- Removable media device supported (Removable media is not supported in multi-initiator and high availability configurations)
- Removable media device supported
- 440 - 500 Mhz PowerPC (PPC)
- Support for multi-initiator and high availability configurations

For details about slot priorities and placement rules, see the PCI adapter placement topic collection for your system.

Operating system or partition requirements

If you are installing a new feature, ensure that you have the software that is required to support the new feature and that you determine whether there are any prerequisites for this feature and attaching devices. To check for the prerequisites, see IBM Prerequisite website (www-912.ibm.com/e_dir/eServerPrereq.nsf).

The adapter is supported on the following versions of the operating systems:

- AIX
 - AIX Version 7.1, or later.
 - AIX Version 6.1, or later.
 - AIX Version 5.3, or later.
- Linux
 - Red Hat Enterprise Linux 5.6 for POWER, or later.
 - SUSE Linux Enterprise Server 11 Service Pack 1, or later.
- IBM i
 - IBM i 7.1, or later.
 - IBM i 6.1, or later.

This adapter requires the following device drivers:

- AIX: devices.pci.1410bd02 device driver package
- Linux:
 - iprutils version 2.4.1 and ipr driver version 2.0.11.6 (or newer) for RHEL4 kernels
 - iprutils version 2.4.1 and ipr driver version 2.2.0.2 (or newer) for RHEL5 kernels
 - iprutils version 2.4.1 and ipr driver version 2.2.0.2 (or newer) for SLES10 kernels

Related tasks:

“Installing the AIX device driver software” on page 224

Learn how to install the AIX device driver software for a PCI adapter.

“Verifying the AIX device driver software” on page 225

Learn how to verify the AIX device driver is installed for a PCI adapter.

 [Installing PCI adapters](#)

Related reference:

 [IBM Prerequisite website](#)

[↗](#) Parts information

[↗](#) PCI adapter placement

“Backplane daughter cards and RAID enablement cards” on page 2

Find links to topics that cover Backplane daughter cards and RAID enablement cards.

PCIe2 1.8 GB Cache RAID SAS Tri-port 6 Gb Adapter (FC 5913; CCIN 57B5)

Learn about the specifications and operating system requirements for the feature code (FC) 5913 adapters.

Overview

The PCI Express (PCIe) generation-2, 1.8 GB Cache RAID SAS Tri-port 6 Gb Adapter is a large cache PCIe2 SAS adapter that provides high-performance capabilities and supports the attachment of serial-attached SCSI (SAS) disks and SAS solid-state drives through mini SAS HD (high density) connectors. The feature code (FC) 5913 has a 1.8 GB write-cache. The adapter must be installed in pairs and must be used in a high availability, multi-initiator RAID configuration with two adapters in dual-controller mode (Dual Storage IOA configuration). Two FC 5913 adapters provide additional performance and adapter redundancy with mirrored write-cache data and mirrored RAID parity footprints between the adapters. If the FC 5913 pairing is broken, then the write cache is disabled. Integrated flash memory with capacitors provides protection of the write cache in case of power failure, without the need for batteries as were used with previous large cache adapters.

To provide the highest bandwidth between two paired feature 5913 adapters for the mirroring of cache data and parity update footprints, a SAS Adapter-to-Adapter (AA) cable is required by default on the third adapter port until maximum device quantity attachment is required. When all three connectors are attaching SAS drives, the communication between the adapter pair is performed through the SAS fabric via the I/O drawer and cabling.

The FC 5913 is a single wide, full-height, short adapter.

Every FC 5913 requires another 6 Gbps SAS RAID adapter (FC 5913) on this server, or on another server, which pairs with the SAS RAID adapter and enables the onboard caches to function. See Figure 61 on page 182 that shows the FC 5913 adapter.

Systems running the AIX or Linux operating systems support either having both 5913 features in the same system or partition, or in two separate systems or partitions. Systems running the IBM i operating system do not support the pairing of adapters on different servers or different partitions, so both the 5913 features must be installed on the same system or partition.

For details about slot priorities and placement rules, see the PCI adapter placement topic collection for your system.

Specifications

Item	Description
------	-------------

Adapter FRU number	
---------------------------	--

	00J0596 (Designed to comply with RoHS requirement)
--	--

I/O bus architecture	
-----------------------------	--

	PCIe2.0 x8
--	------------

Slot requirement	
-------------------------	--

	One PCIe x8 slot per adapter.
--	-------------------------------

Adapters are installed in pairs.

For higher availability, place adapters in separate enclosures where supported.

Cables

Specific X , YO, AA, or AT SAS cables with HD connectors are used to attach to the expansion drawers.

SAS device attachment requires specific cables that are provided with the subsystem or device features being attached. Special cabling is required for multi-initiator and high availability configurations.

Voltage

3.3 V

Form factor

Short, full-height

Maximum number

For the maximum adapters supported, see the PCI adapter placement topic collection for your system.

Attributes provided

- Provides three mini-SAS high-density (HD) connectors for attaching the SAS drives in the FC 5887 EXP24S, FC 5886 EXP12S, FC 5802, or FC 5803 12X PCIe I/O drawers. A maximum of three EXP24S, or six EXP12S, or a mix of each can be attached to the same FC 5913 pair.

Note: If SSDs are installed in one of the FC 5886 EXP12S drawers, then a second FC 5886 is not allowed to be attached (or cascaded) to the first FC 5886 on that port.

- Supports a maximum of 72 hard disk drives or a maximum 24 SSDs (depending on the type of enclosures attached), or a combination of both with specific placement rules for each enclosure.
- If FC 5913 is controlling drives that are installed in FC 5802 or FC 5803, then the FC 5913 adapter pairs must be in that FC 5802 or FC 5803. The AA cable is required on the top mini-SAS HD port of the adapter pair. Use a pair of FC 3689, 0.6 m AT SAS cables to connect the FC 5913 adapter pair to the SAS connectors. An FC 5887 EXP24S or FC 5886 EXP12S can be attached to the other port on the FC 5913 pair.
- An AA SAS cable with HD connectors attached to the FC 5913 pair provides a higher performance path for mirrored write-cache data and mirrored RAID parity footprints between the adapters and is required unless all three ports are being used to attach EXP24S or EXP12S I/O drawers.

Note: Solid-state drives (SSDs) are not allowed on the top port (T2).

- Support of the SAS Serial SCSI Protocol (SSP) and Serial Management Protocol (SMP).
- Provides RAID 0, RAID 5, RAID 6, and RAID 10 with hot-spare capability. System level mirroring through the operating system is also supported. JBOD functionality (512 byte) is not supported except for the initial formatting to 528 bytes of new devices, as required.
- A single pair of FC 5913 adapters is not supported to attach to both halves of an FC 5887 EXP24S drawer that is configured in mode 2.
- Double looping of the I/O enclosure system connection is suggested to enhance performance when more than four adapters are installed in either FC 5803 or FC 5873.

The following figure shows the adapter.

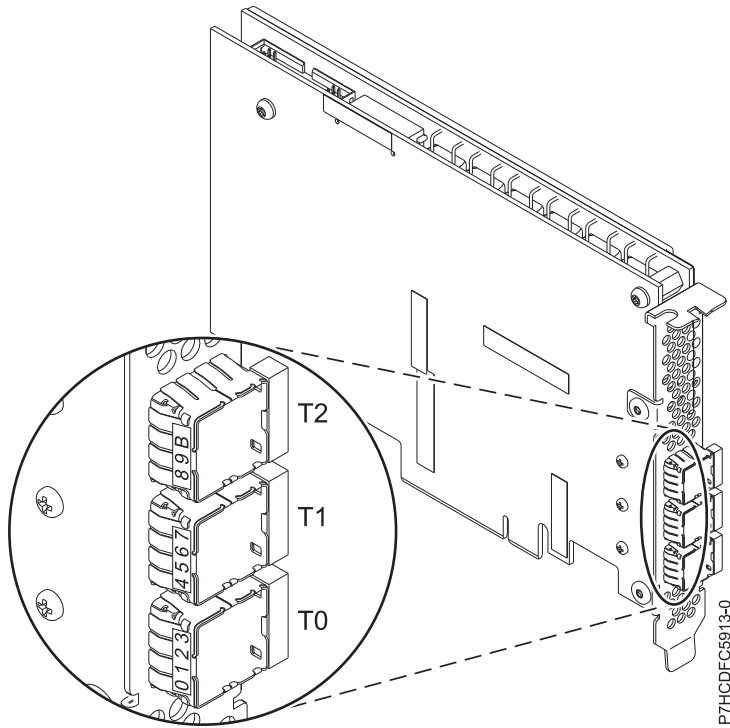

Figure 61. 5913 Adapter

Operating system or partition requirements

This adapter is supported for the following versions of operating systems:

- AIX
 - AIX Version 7.1 with the 7100-01 Technology Level, or later
 - AIX Version 7.1 with Service Pack 3, or later
 - AIX Version 6.1 with the 6100-07 Technology Level, and Service Pack 5, or later
 - AIX Version 6.1 with the 6100-06 Technology Level, and Service Pack 5, or later
 - AIX Version 6.1 with the 6100-05 Technology Level, and Service Pack 6, or later
 - AIX Version 5.3 with the 5300-12 Technology Level and Service Pack 4, or later
- Linux
 - Red Hat Enterprise Linux 6.1 for POWER, or later
 - Red Hat Enterprise Linux 5.7 for POWER, or later
 - SUSE Linux Enterprise Server 11, Service Pack 1, or later (with update package)
 - SUSE Linux Enterprise Server 10, Service Pack 4, or later
 - For support details, see the Linux Alert website (www14.software.ibm.com/webapp/set2/sas/f/lopdiags/info/LinuxAlerts.htm)
- IBM i
 - IBM i 7.1 Technology Refresh 3.
 - IBM i 6.1.1 with Resave E (RS611-E).
- VIOS
 - VIOS support requires VIOS 2.2.0.12-FP24 SP02, or later

Other important requirements for adapter installation

- If you are attaching a new or existing FC 5886 to an FC 5913 adapter, verify that the latest System Enclosure Services (SES) code is applied to the FC 5886 before attaching to the FC 5913 adapter, see the IBM Prerequisites website.
- If you are attaching a new or existing FC 5887 to an FC 5913 adapter, verify that the latest System Enclosure Services (SES) code is applied to the FC 5887 before attaching to the FC 5913 adapter, see the IBM Prerequisites website.
- If you are installing the FC 5913 in the 8202-E4B, 8202-E4C, 8202-E4D, 8205-E6B, 8205-E6C, or 8205-E6D system, turn off the acoustic mode by using advanced system management (ASM) options. For instructions, see *Configuring the acoustic mode control*.
- If you are migrating existing SAS disk enclosures and devices from existing previous SAS adapters, an automatic sector conversion takes place for use with the new FC 5913 adapters. For information about the migrating procedures, see *Upgrading the adapter*.

POWER6 restrictions

If you are installing the FC 5913 in a POWER6 server, the following restrictions apply:

- The FC 5913 adapter is not supported in the POWER6 system units and must be placed in the I/O expansion units attached to the server units.
- The FC 5913 adapter is not supported for controlling the boot or load source drives on POWER6 systems.

Related tasks:

Serial-attached SCSI cable planning

Learn about how to install the SAS cables to the hard disk drives or solid-state drives.

[🔗 Installing PCI adapters](#)

Related reference:

“Important partitioning considerations with dual-slot and multi-adapter configurations” on page 4

Learn about partitioning considerations with dual-slot and multi-adapter configurations.

[🔗 IBM Prerequisite website](#)

[🔗 Parts information](#)

[🔗 PCI adapter placement](#)

“Backplane daughter cards and RAID enablement cards” on page 2

Find links to topics that cover Backplane daughter cards and RAID enablement cards.

Related information:

[🔗 Logical partitioning](#)

Information about logical partitioning.

[🔗 Changing partition profile properties](#)

Information about changing partition profile properties by using the HMC.

Dual IOA Enablement Card (FC 5662)

Information about the specifications for the Dual IOA Enablement Card.

SAS RAID controllers for AIX

Information about usage and maintenance information for the SAS RAID Controller for the AIX.

SAS RAID controllers for IBM i

Information about usage and maintenance information for the SAS RAID Controller for the IBM i.

SAS RAID controllers for Linux

Information about the usage and maintenance information for the SAS RAID Controller for Linux.

PCIe2 RAID SAS Adapter Dual-port 6Gb (FC ESA1; CCIN 57C4)

Learn about the specifications and operating system requirements for the feature code (FC) ESA1 adapters.

Overview

The FC ESA1 is a full-height adapter and the FC ESA2 is a low-profile adapter. The names of these two adapters are:

- FC ESA1: PCIe2 RAID SAS Adapter Dual-port 6Gb
- FC ESA2: PCIe2 RAID SAS Adapter Dual-port 6Gb LP

The PCI Express generation-2 (PCIe2), RAID SAS dual-port 6Gb Adapter provides high-performance solid-state drives (SSD) controller functions by using the PCIe2 technology. The adapter does not have write cache and thus pairing with another PCIe2 RAID SAS Adapter Dual-port 6Gb (either FC ESA1 or FC ESA2) is optional. Pairing can provide controller redundancy and enhanced performance. There are no batteries in the adapter to maintain.

The PCIe2 RAID SAS Adapter Dual-port 6Gb supports SSD only. Hard disk drives (HDD) are not supported by this adapter. The 69 GB SSD features are not supported.

The adapter provides two mini-SAS high density (HD) connectors for the attachment of SSDs located in the FC 5887 EXP24S, FC 5802, or FC 5803 12X PCIe I/O drawers. X , YO, or AT SAS cables with HD connectors are used to attach to these drawers. A maximum of 18, 26, or 24 SSD can be controlled depending on the I/O drawers being used. Only one drawer can be controlled. The FC 5802 12X PCIe I/O drawer has a maximum of 18 SSDs. The FC 5803 PCIe I/O Drawer has a maximum of 26 SSDs. The FC 5887 EXP24S Drawer has a maximum of 24 SSDs. If the SSDs are located in FC 5802 or FC 5803, one or both of the controlling adapter pair must be located in that FC 5802 or FC 5803.

A single adapter or a pair of adapters provides RAID 0, RAID 5, RAID 6, and RAID 10 configurations for systems or partitions running the AIX or Linux operating system and VIOS. The PCIe2 RAID SAS Adapter Dual-port 6Gb does not support JBOD. The adapter provides RAID 5 and RAID 6 for systems or partitions running the IBM i operating system. IBM i provides both mirroring and data spreading. Systems or partitions running the AIX or Linux operating system and VIOS provide mirroring (logical volume manager (LVM)).

For details about slot priorities and placement rules, see the PCI adapter placement topic collection for your system.

Specifications

Item Description

Adapter FRU number

00E6727 (Designed to comply with RoHS requirement)

I/O bus architecture

PCIe2.0 x8

Slot requirement

One PCIe2, x8, slot per adapter.

Cables

Specific X , YO, or AT SAS cables with HD connectors are used to attach to the expansion drawers.

Voltage

3.3 V

Form factor

Regular, full-height

Maximum number

For the maximum adapters supported, see the PCI adapter placement topic collection for your system.

Attributes provided

- High-performance SSD SAS adapter without write cache
- Optional pairing (Multi-Initiator and High Availability or Dual Storage IOA)
- Support of the SAS Serial SCSI Protocol (SSP) and Serial Management Protocol (SMP).

Operating system or partition requirements

This adapter is supported for the following versions of operating systems:

- AIX
 - AIX Version 7.1 with the 7100-01 Technology Level, and Service Pack 4, or later.
 - AIX Version 7.1 with the 7100-00 Technology Level, and Service Pack 6, or later.
 - AIX Version 6.1 with the 6100-07 Technology Level, and Service Pack 4, or later.
 - AIX Version 6.1 with the 6100-06 Technology Level, and Service Pack 8, or later.
 - AIX Version 5.3 with the 5300-12 Technology Level, and Service Pack 6, or later.
- Linux
 - Red Hat Enterprise Linux 6.2 for POWER, or later
 - Red Hat Enterprise Linux 5.8 for POWER, or later
 - Novel SUSE Linux Enterprise Server 11, Service Pack 2, or later (with update package)
 - Novel SUSE Linux Enterprise Server 10, Service Pack 4, or later
 - See the Linux Alert site for the support details.
- IBM i
 - IBM i 6.1.0 with machine code 6.1.1, or later.
- VIOS
 - VIOS support requires VIOS 2.2.1.4, or later

Related tasks:

Serial-attached SCSI cable planning

Learn about how to install the SAS cables to the hard disk drives or solid-state drives.

 [Installing PCI adapters](#)

Related reference:

“Important partitioning considerations with dual-slot and multi-adapter configurations” on page 4

Learn about partitioning considerations with dual-slot and multi-adapter configurations.

 [IBM Prerequisite website](#)

 [Parts information](#)

 [PCI adapter placement](#)

“Backplane daughter cards and RAID enablement cards” on page 2

Find links to topics that cover Backplane daughter cards and RAID enablement cards.

Related information:

 [Logical partitioning](#)

Information about logical partitioning.

 [Changing partition profile properties](#)

Information about changing partition profile properties by using the HMC.

Dual IOA Enablement Card (FC 5662)

Information about the specifications for the Dual IOA Enablement Card.

SAS RAID controllers for AIX

Information about usage and maintenance information for the SAS RAID Controller for the AIX.

SAS RAID controllers for IBM i

Information about usage and maintenance information for the SAS RAID Controller for the IBM i.

SAS RAID controllers for Linux

Information about the usage and maintenance information for the SAS RAID Controller for Linux.

PCIe2 RAID SAS Adapter Dual-port 6-Gb LP (FC ESA2; CCIN 57C4)

Learn about the specifications and operating system requirements for the feature code (FC) ESA2 adapters.

Overview

The FC ESA1 is a full-height adapter and the FC ESA2 is a low-profile adapter. The names of these two adapters are:

- FC ESA1: PCIe2 RAID SAS Adapter Dual-port 6-Gb
- FC ESA2: PCIe2 RAID SAS Adapter Dual-port 6-Gb LP

The PCI Express generation-2 (PCIe2), RAID SAS dual-port 6-Gb Adapter provides high-performance solid-state drives (SSD) controller functions by using the PCIe2 technology. The adapter does not have write cache and thus pairing with another PCIe2 RAID SAS Adapter Dual-port 6-Gb (either FC ESA1 or FC ESA2) is optional. Pairing can provide controller redundancy and enhanced performance. There are no batteries in the adapter to maintain.

The PCIe2 RAID SAS Dual-port 6-Gb Adapter supports SSD only. Hard disk drives (HDD) are not supported by this adapter. The 69 GB SSD features are not supported.

The adapter provides two mini-SAS high-density (HD) connectors for the attachment of SSDs located in the FC 5887 EXP24S, FC 5802, or FC 5803 12X PCIe I/O drawers. X, YO, or AT SAS cables with HD connectors are used to attach to these drawers. A maximum of 18, 26, or 24 SSD can be controlled depending on the I/O drawers being used. Only one drawer can be controlled. The FC 5802 12X PCIe I/O drawer has a maximum of 18 SSDs. The FC 5803 PCIe I/O Drawer has a maximum of 26 SSDs. The FC 5887 EXP24S Drawer has a maximum of 24 SSDs. If the SSDs are located in FC 5802 or FC 5803, one or both of the controlling adapter pair must be located in that FC 5802 or FC 5803.

A single adapter or a pair of adapters provides RAID 0, RAID 5, RAID 6, and RAID 10 configurations for systems or partitions running the AIX or Linux operating system and VIOS. The PCIe2 RAID SAS Dual-port 6-Gb adapters do not support JBOD. The adapter provides RAID 5 and RAID 6 for systems or partitions running the IBM i operating system. IBM i provides both mirroring and data spreading. Systems or partitions running the AIX or Linux operating system and VIOS provide mirroring (logical volume manager (LVM)).

For details about slot priorities and placement rules, see the PCI adapter placement topic collection for your system.

Specifications

Item **Description**

Adapter FRU number

00E6725 (Designed to comply with RoHS requirement)

I/O bus architecture

PCIe2.0 x8

Slot requirement

One PCIe2, x8, low-profile slot per adapter.

Cables

Specific X , YO, or AT SAS cables with HD connectors are used to attach to the expansion drawers.

Voltage

3.3 V

Form factor

Short, low-profile

Maximum number

For the maximum adapters supported, see the PCI adapter placement topic collection for your system.

Attributes provided

- High-performance SSD SAS adapter without write cache
- Optional pairing (Multi-Initiator and High Availability or Dual Storage IOA)
- Support of the SAS Serial SCSI Protocol (SSP) and Serial Management Protocol (SMP).

Operating system or partition requirements

This adapter is supported for the following versions of operating systems:

- AIX
 - AIX Version 7.1 with the 7100-01 Technology Level, and Service Pack 4, or later.
 - AIX Version 7.1 with the 7100-00 Technology Level, and Service Pack 6, or later.
 - AIX Version 6.1 with the 6100-07 Technology Level, and Service Pack 4, or later.
 - AIX Version 6.1 with the 6100-06 Technology Level, and Service Pack 8, or later.
 - AIX Version 5.3 with the 5300-12 Technology Level, and Service Pack 6, or later.
- Linux
 - Red Hat Enterprise Linux 6.2 for POWER, or later
 - Red Hat Enterprise Linux 5.8 for POWER, or later
 - Novel SUSE Linux Enterprise Server 11, Service Pack 2, or later (with update package)
 - Novel SUSE Linux Enterprise Server 10, Service Pack 4, or later
 - See the Linux Alert site for the support details.
- IBM i
 - IBM i 7.1, or later.
 - IBM i 6.1.0 with machine code 6.1.1, or later.
- VIOS
 - VIOS support requires VIOS 2.2.1.4, or later

Related tasks:

Serial-attached SCSI cable planning

Learn about how to install the SAS cables to the hard disk drives or solid-state drives.

[🔗 Installing PCI adapters](#)

Related reference:

“Important partitioning considerations with dual-slot and multi-adapter configurations” on page 4
Learn about partitioning considerations with dual-slot and multi-adapter configurations.

[🔗 IBM Prerequisite website](#)

[🔗 Parts information](#)

[🔗 PCI adapter placement](#)

“Backplane daughter cards and RAID enablement cards” on page 2

Find links to topics that cover Backplane daughter cards and RAID enablement cards.

Related information:

↳ Logical partitioning
Information about logical partitioning.

↳ Changing partition profile properties
Information about changing partition profile properties by using the HMC.

Dual IOA Enablement Card (FC 5662)
Information about the specifications for the Dual IOA Enablement Card.

SAS RAID controllers for AIX
Information about usage and maintenance information for the SAS RAID Controller for the AIX.

SAS RAID controllers for IBM i
Information about usage and maintenance information for the SAS RAID Controller for the IBM i.

SAS RAID controllers for Linux
Information about the usage and maintenance information for the SAS RAID Controller for Linux.

PCIe 2-Line WAN with Modem (FC 2893 (EN13), 2894 (EN14); CCIN 576C)

Learn about the features of the PCIe 2-Line WAN with Modem.

This adapter is a 2-line per port WAN with Modem PCIe adapter. Port 0 is the modem port and supports V.92 56K Async PPP, V.92 data modem, V.44 data compression, V.34 FAX modem and FAX functions, such as ECM and 2D/1D conversion. Port 0 does not provide Sync modem capabilities (SDLC and Sync PPP). Port 1 is the RVX port and provides Bisync functionality.

2893 is the non-CIM (Complex Impedance Matching) version offered in all countries and regions except Australia and New Zealand.

2894 is the CIM (Complex Impedance Matching) version offered only in Australia and New Zealand.

The FRU part numbers for the adapter are:

- FC 2893 and 2894: 44V5323

Adapter type
Short, x4, PCIe

If you are installing a new feature, ensure that you have the software that is required to support the new feature and that you determine whether there are any prerequisites for this feature and attaching devices. To check for the prerequisites, see IBM Prerequisite website (www-912.ibm.com/e_dir/eServerPrereq.nsf).

For details about slot priorities and placement rules, see the PCI adapter placement topic collection for your system.

Operating system or partition requirements

If you are installing a new feature, ensure that you have the software that is required to support the new feature and that you determine whether there are any prerequisites for this feature and attaching devices. To check for the prerequisites, see IBM Prerequisite website (www-912.ibm.com/e_dir/eServerPrereq.nsf).

The adapter is supported on the following versions of the operating systems:

- Linux
 - Red Hat Enterprise Linux 5.6 for POWER, or later
 - SUSE Linux Enterprise Server 11 Service Pack 1, or later
- IBM i
 - IBM i 7.1, or later

- IBM i 6.1, or later

Related tasks:

[🔗 Installing PCI adapters](#)

Related reference:

[🔗 IBM Prerequisite website](#)

[🔗 Parts information](#)

[🔗 PCI adapter placement](#)

“Backplane daughter cards and RAID enablement cards” on page 2

Find links to topics that cover Backplane daughter cards and RAID enablement cards.

PCIe2 3.1GB Cache Integrated SAS RAID Adapter (CCIN 57C3) included in Feature 5888

Learn about the specifications and operating system requirements for the PCIe2 3.1GB Cache Integrated SAS RAID adapter that is integrated with the EXP30 Ultra SSD I/O Drawer (feature code 5888 PCIe storage enclosure). The adapter reports as PCIe2 3.1GB Cache RAID SAS Enclosure 6Gb x8.

Overview

The PCIe2 3.1GB Cache Integrated SAS RAID adapter is an internal PCI Express generation-2 (PCIe2), serial-attached SCSI (SAS) Random Array of Independent Disks (RAID) adapter integrated into the 5888 PCIe storage enclosure. The adapter contains the SAS RAID controller and SAS Expander. The internal adapter with the SAS RAID controller and SAS Expander is called as the enclosure RAID module (ERM). This adapter supports the attachment of the 1.8 inch SAS solid-state drive feature ES02. The 5888 PCIe storage enclosure connects to the server via a PCIe x8 cable from each ERM PCIe x8 cable port. The PCIe cable is connected to the GX ++ PCIe2 adapter in the server.

The FC 5888 PCIe storage enclosure is always supplied with two PCIe2 3.1GB Cache Integrated SAS RAID adapters preinstalled. These must be used in a high availability, multi-initiator RAID configuration with the two adapters in dual-controller mode (Dual Storage IOA configuration).

Each of the two high performance, integrated SAS controllers physically provide 3.1 GB write-cache. Working as a pair, they provide additional performance and adapter redundancy with mirrored write-cache data and mirrored RAID parity footprints between the adapters. The cache contents are designed to be protected by integrated flash memory with capacitors in case of power failure without the need for batteries as were used with previous large cache adapters. If the pairing is broken, write-cache is disabled after existing cache content is written out to the drives and performance may be degraded until the controller pairing is reestablished.

Both controllers can support a minimum of 6 SSD and a maximum of 30 SSD. The SAS SSD bays are always physically one set of drives, even though there may be multiple RAID arrays in this one set. With two or more RAID arrays, each RAID array can be optimized to either of the integrated SAS controllers to take advantage of Active/Active performance improvements via the R/W bandwidth of both adapters.

The location codes for the PCIe connector on the PCIe2 3.1GB Cache Integrated SAS RAID adapter are:

1. Internal adapter ERM 1: C1-T3
2. Internal adapter ERM 2: C2-T3

See Figure 62 on page 190 for the location codes for the PCIe2 3.1GB Cache Integrated SAS RAID adapter in the 5888 PCIe storage enclosure.

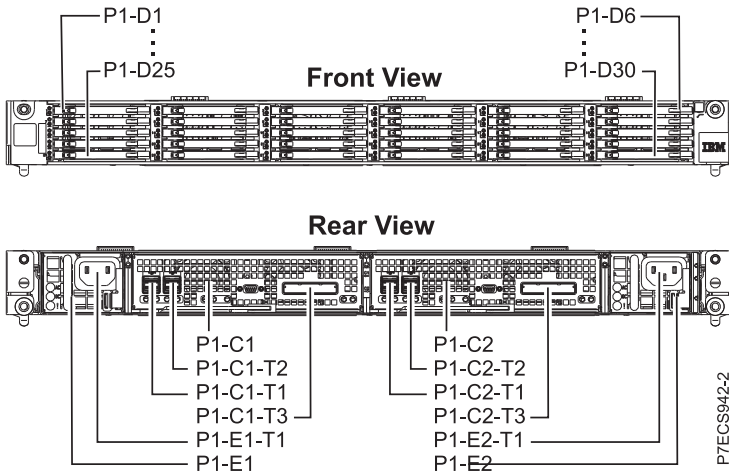
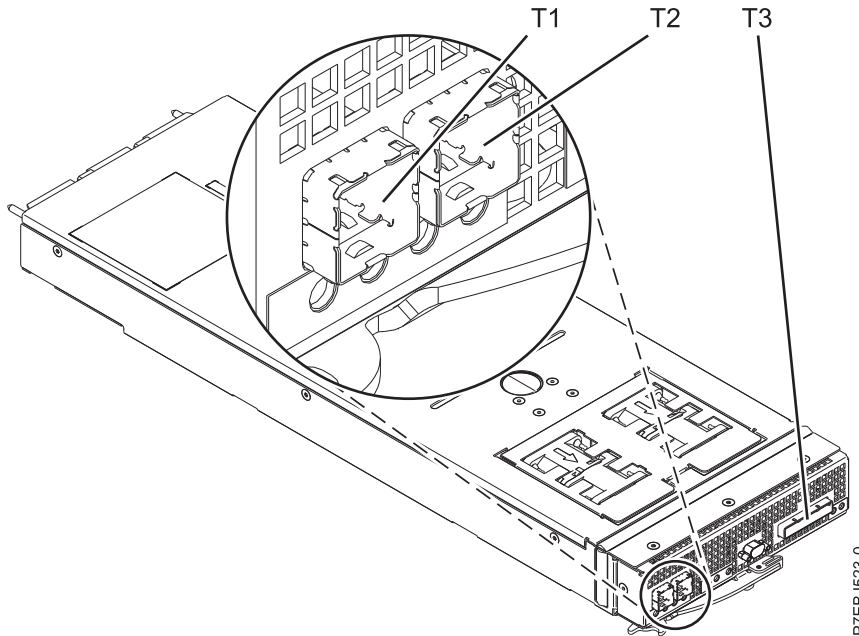

Figure 62. Location codes of the PCIe2 3.1GB Cache Integrated SAS RAID adapter

Servers running the AIX or Linux operating system support both adapters RAID controllers owned by the same or different partitions. The controllers provide RAID 0, RAID 5, RAID 6, and RAID 10 configurations for servers running the AIX or Linux operating system, and supported by VIOS. AIX, Linux, or VIOS also provide mirroring (logical volume manager (LVM)) capabilities.

For the 5888 PCIe storage enclosure, these adapters are not maintained concurrently, although many other components in the 5888 PCIe storage enclosure can be maintained concurrently.

See figure that shows the ERM.



Note: Connectors T1 and T2 are not used on FC 5888 PCIe storage enclosure.

Figure 63. CCIN 57C3 PCIe2 3.1GB Cache RAID SAS Enclosure 6Gb x8

Specifications

Item	Description
------	-------------

Adapter CCIN number

57C3

I/O bus architecture

PCIe2 x8

Cables

PCIe cables FC EN05 and FC EN07.

Voltage

3.3 V

Operating system or partition requirements

This adapter is supported for the following versions of operating systems:

- AIX
 - AIX Version 7.1 with the 7100-01 Technology Level, and Service Pack 4, or later.
 - AIX Version 7.1 with the 7100-00 Technology Level, and Service Pack 6, or later.
 - AIX Version 6.1 with the 6100-07 Technology Level, and Service Pack 4, or later
 - AIX Version 5.3 with the 5300-12 Technology Level and Service Pack 6, or later
- Linux
 - Red Hat Enterprise Linux 6.2 for POWER, or later
 - Red Hat Enterprise Linux 5.8 for POWER, or later
 - SUSE Linux Enterprise Server 11, Service Pack 2, or later (with update package)
 - SUSE Linux Enterprise Server 10, Service Pack 4, or later
 - For support details, see the Linux Alert website (www14.software.ibm.com/webapp/set2/sas/f/lopdiags/info/LinuxAlerts.htm)
- VIOS
 - VIOS support requires VIOS 2.2.1.4, or later

Related tasks:

Serial-attached SCSI cable planning

Learn about how to install the SAS cables to the hard disk drives or solid-state drives.

 [Installing PCI adapters](#)

Related reference:

“Important partitioning considerations with dual-slot and multi-adapter configurations” on page 4
Learn about partitioning considerations with dual-slot and multi-adapter configurations.

 [IBM Prerequisite website](#)

 [Parts information](#)

 [PCI adapter placement](#)

“Backplane daughter cards and RAID enablement cards” on page 2

Find links to topics that cover Backplane daughter cards and RAID enablement cards.

Related information:

 [Logical partitioning](#)

Information about logical partitioning.

 [Changing partition profile properties](#)

Information about changing partition profile properties by using the HMC.

Dual IOA Enablement Card (FC 5662)

Information about the specifications for the Dual IOA Enablement Card.

SAS RAID controllers for AIX

Information about usage and maintenance information for the SAS RAID Controller for the AIX.

SAS RAID controllers for IBM i

Information about usage and maintenance information for the SAS RAID Controller for the IBM i.

SAS RAID controllers for Linux

Information about the usage and maintenance information for the SAS RAID Controller for Linux.

IBM Flash Adapter 90 (PCIe2 0.9TB) (FC ES09; CCIN 578A)

Find information about the specifications, operating system requirements, and drivers for the IBM PCIe Flash adapter. You can also find information about installing, formatting, and troubleshooting the IBM PCIe Flash adapter.

Overview and specifications of the IBM Flash Adapter 90 (PCIe2 0.9TB) (FC ES09; CCIN 578A)

Find information about the overview, specifications, and operating system requirements for the feature code (FC) ES09 adapters.

Overview

The IBM Flash Adapter 90 (PCIe2 0.9TB) is a PCIe enabled high-performance enterprise multi-level cell (eMLC) Flash storage adapter that provides 900 GB of usable storage capacity. It is a single-wide, full-height, half-width, generation-2 PCIe adapter. The adapter capable of providing a read bandwidth of 1.3 gigabyte per second (GBps) and a 4K-read input/output operations per second (IOPS) of 325,000. The adapter increases the performance of applications that require larger and faster data buffer areas.

As the device does not contain an internal RAID, you can mirror the FC ES09 at the adapter level to provide enhanced data integrity. Install the adapter in pairs to enable mirroring.

The FC ES09 adapter provides the following features:

- 32 nm Toshiba eMLC NAND Flash
- Capacitive emergency power loss protection
- Minimal host processor and RAM requirements
- Native block size of 4096
- 512 byte access support

Figure 64 on page 193 shows the IBM Flash Adapter 90 (PCIe2 0.9TB).

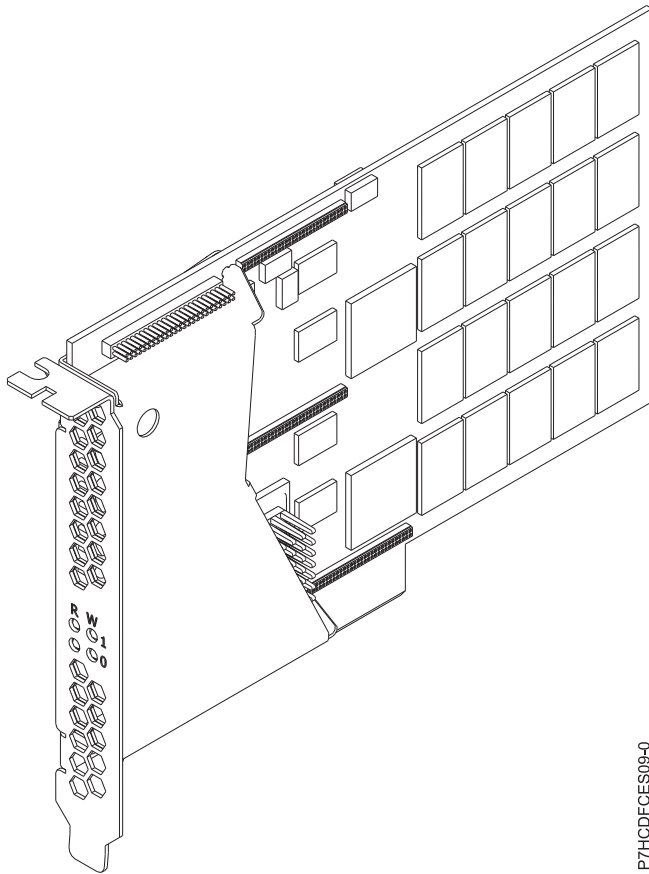

P7HCDFCES09-0

Figure 64. IBM Flash Adapter 90 (PCIe2 0.9TB)

Find the following information about the IBM Flash Adapter 90 (PCIe2 0.9TB):

- “Specifications”
- “Operating system or partition requirements” on page 194
- “Device drivers” on page 194
- “Installing the IBM Flash Adapter 90 (PCIe2 0.9TB)” on page 194
- “Installing the device driver for the IBM Flash Adapter 90 (PCIe2 0.9TB)” on page 196
- “Verifying the storage device availability” on page 196
- “Formatting the IBM Flash Adapter 90 (PCIe2 0.9TB)” on page 197
- “Using the IBM Flash Adapter 90 (PCIe2 0.9TB)” on page 199
- “The `rs_info` Utility for the IBM Flash adapter 90 (PCIe2 0.9TB)” on page 199

Specifications

Item Description

Adapter FRU number

00AF045 (Designed to comply with RoHS requirement).

I/O bus architecture

PCIe 2.0, x8.

Slot requirement

One PCIe x8 slot.

Cables

No cables are required.

Voltage

3.3 V

Form factor

Full-height, half-width.

Maximum number

For the maximum adapters supported, see the PCI adapter placement topic collection for your system.

Storage

900 GB.

Operating system or partition requirements

This adapter is supported for the following versions of operating systems:

- AIX
 - AIX Version 7.1 with the 7100-01 Technology Level and Service Pack 9, or later.
 - AIX Version 7.1 with the 7100-02 Technology Level and Service Pack 4, or later.
 - AIX Version 6.1 with the 6100-07 Technology Level, and Service Pack 9, or later.
 - AIX Version 6.1 with the 6100-08 Technology Level, and Service Pack 4 or later.
- Linux
 - Red Hat Enterprise Linux Version 6.5, or later.

Device drivers

The adapter requires the following drivers:

- AIX operating system requires *rsxx* device driver Rational® Portfolio Manager (RPM).
For instructions to install the device driver, see “Installing the device driver in an AIX system or logical partition” on page 196.
- Linux operating systems:
 - The *rsxx* device driver is automatically installed in Red Hat Enterprise Linux 6.5, or later versions.
For instructions to install the device driver, see “Installing the device driver in a Linux VM” on page 196.

Installing the IBM Flash Adapter 90 (PCIe2 0.9TB)

Find information about installing the IBM Flash Adapter 90 (PCIe2 0.9TB) and verifying the installation in a system that is running the AIX or Linux operating system.

Important: Ensure that the IBM Flash Adapter 90 (PCIe2 0.9TB) is supported on your system.

1. To install the IBM Flash Adapter 90 (PCIe2 0.9TB) in your system, go to Installing PCI adapters and complete the installation procedure for the system you are working with.
2. After you complete installing the adapter, verify the adapter installation.
 - For instructions to verify installation in an AIX logical partition, see “Verifying the IBM Flash Adapter 90 (PCIe2 0.9TB) installation in an AIX logical partition.”
 - For instructions to verify installation in a Linux virtual machine (VM), see “Verifying the IBM Flash Adapter 90 (PCIe2 0.9TB) installation in a Linux VM” on page 195.

Verifying the IBM Flash Adapter 90 (PCIe2 0.9TB) installation in an AIX logical partition:

Learn to verify the adapter installation in the system or logical partition that is running the AIX operating system.

1. Use the HMC to verify the adapter installation. For instructions, see Verifying the installed part.
2. Verify that the physical adapter is partitioned to the logical partition that you wanted the adapter to be available in.

Note: Ensure that the adapter is detected in the partition.

3. To detect the installed adapter in the system or logical partition that is running the AIX operating system, run the following command:

```
cfgmgr
```

Note: The following message is displayed if you are installing the IBM Flash Adapter 90 (PCIe2 0.9TB) for the first time in the system or logical partition.

The following screen is displayed indicating that the adapter is installed and detected in the VM.

```
0514-621 WARNING: The following device packages are required for
                    device support but are not currently installed.
                    devices.pciex.flash:devices.pciex.pciex1014.4aa.1014.70.3:
                    devices.pciex.1410aa0414107000:devices.pciex.14107000:
                    devices.pciex.pciex1014.4aa.3:devices.pciex.1410aa04:
                    devices.pciex.pciexclass.050100:
                    devices.pciex.pciexclass.000501
```

4. If the IBM Flash Adapter 90 (PCIe2 0.9TB) is already listed as available, no further installation steps are required.
5. Verify if whether the Flash adapter is available by running the following command:

```
-bash-4.2# lsdev -Cc disk
```

The following screen is displayed:

```
hdisk0 Available 00-00-00 Other SAS Disk Drive
hdisk1 Available 07-00-01 IBM Flash Adapter Disk
```

Next, you can install the device driver. For instructions to install the device driver in system or logical partition that is running the AIX operating system, see “Installing the device driver in an AIX system or logical partition” on page 196.

Verifying the IBM Flash Adapter 90 (PCIe2 0.9TB) installation in a Linux VM:

Learn how to verify the Flash storage adapter installation in a Linux virtual machine (VM).

1. Use the HMC to verify the adapter installation. For instructions, see Verifying the installed part.
2. Verify if whether the physical adapter is partitioned to the logical partition that you wanted the adapter to be available in.

Note: Ensure that the adapter is detected in the partition.

3. To detect the installed adapter in the system or VM that is running the Linux operating system, run the following command:

```
lspci | grep IBM
```

The following screen is displayed indicating that the adapter is installed and detected in the VM.

```
01:00.0 FLASH memory: IBM Device 04aa (rev 03)
```

Next, you can install the device driver. For instructions to install the device driver in a system or logical partition that is running the Linux operating system, see “Installing the device driver in a Linux VM.”

Installing the device driver for the IBM Flash Adapter 90 (PCIe2 0.9TB)

Find information about installing the IBM Flash Adapter 90 (PCIe2 0.9TB) device driver in a system that is running the AIX or Linux operating system.

Important: Ensure that you have verified that the IBM Flash Adapter 90 (PCIe2 0.9TB) is installed in your system.

You can choose from the following options that are based on the operating system that controls the adapter:

- “Installing the device driver in an AIX system or logical partition”
- “Installing the device driver in a Linux VM”

Installing the device driver in an AIX system or logical partition:

Learn how to install the device driver for the IBM Flash Adapter 90 (PCIe2 0.9TB) in an AIX logical partition.

Important: You must install the device driver before you can use the installed IBM Flash Adapter 90 (PCIe2 0.9TB).

Complete the following steps to install the device driver in an AIX system or logical partition:

1. Download the device driver from Fix Central (www.ibm.com/support/fixcentral).
2. Install the rpm (as root or with root permissions) by using the following command:
`rpm -ihv xxx.x.x`, where `xxx.x.x` is the rpm-name.
3. Run `cfgmgr`.

After the device driver is installed, verify that the Flash storage adapter is available. For instructions, see “Verifying the storage device availability in an AIX system or logical partition” on page 197.

Installing the device driver in a Linux VM:

Learn how to install the device driver for the IBM Flash Adapter 90 (PCIe2 0.9TB) in a Linux virtual machine (VM).

Note: Red Hat Enterprise Linux Version 6.5 uses the `rsxx` device driver to control the Flash storage adapter.

1. To download and install the `rsxx_utils` package, see the IBM Service and Productivity Tools website (<http://www14.software.ibm.com/webapp/set2/sas/f/lopdiags/home.html>).
2. After the device driver is installed, verify that the Flash storage adapter is available. For instructions, see “Verifying the storage device availability in a Linux VM” on page 197.

Verifying the storage device availability

Find information about verifying the storage device (IBM Flash Adapter 90 (PCIe2 0.9TB)) availability after you have installed the device driver in a system that is running the AIX or Linux operating system.

Important: Ensure that you have installed the device driver for the IBM Flash Adapter 90 (PCIe2 0.9TB) for the operating system that the adapter is installed in.

To install the device driver in a system that is running the AIX operating system, see “Installing the device driver in an AIX system or logical partition.”

To install the device driver in a system that is running the Linux operating system, see “Installing the device driver in a Linux VM” on page 196.

You can choose from the following options that are based on the operating system that controls the adapter:

- “Verifying the storage device availability in an AIX system or logical partition”
- “Verifying the storage device availability in a Linux VM”

Verifying the storage device availability in an AIX system or logical partition:

Learn how to verify the IBM Flash Adapter 90 (PCIe2 0.9TB) availability as a storage device in a system that is running the AIX operating system.

1. To verify that the installed adapter is available in the system or logical partition that is running the AIX operating system, run the following command:

lsdev -Cc disk

2. The following screen is displayed indicating that the adapter is installed and ready to use in the system or logical partition.

```
hdisk0 Available 00-00-00 Other SAS Disk Drive
hdisk1 Available 07-00-01 IBM Flash Adapter Disk
...
```

Verifying the storage device availability in a Linux VM:

Learn how to verify the IBM Flash Adapter 90 (PCIe2 0.9TB) availability as a storage device in a system or virtual machine (VM) that is running the Linux operating system.

1. To verify that the installed adapter in the system or VM that is running the Linux operating system is available, run the following command:

ls /dev/rsxx*

2. The following screen is displayed indicating that the adapter is installed and ready to use in the VM.

```
/dev/rsxx0
...
```

Formatting the IBM Flash Adapter 90 (PCIe2 0.9TB)

Find information about formatting the IBM Flash Adapter 90 (PCIe2 0.9TB) in a system that is running the AIX or Linux operating system.

Use this procedure to format the installed or replaced IBM Flash Adapter 90 (PCIe2 0.9TB) PCIe storage device.

Choose one of the following options based on the operating system that controls the adapter:

- “Formatting the device in an AIX system or an AIX logical partition”
- “Formatting the device in a Linux VM” on page 198

Formatting the device in an AIX system or an AIX logical partition:

Learn how to format the IBM Flash Adapter 90 (PCIe2 0.9TB) device in an AIX system or an AIX logical partition.

Important: If you format the device, the data on the device will be destroyed. Ensure that you back up the data before you format the device.

To format the installed or replaced Flash storage adapter device by using the diagnostic command, complete the following steps:

1. Log in as root user.
2. At the command line, type `diag` and press Enter.
3. On the Diagnostic Operating Instructions display, press Enter to continue.
4. On the Function Selection display, select **Task Selection**.
5. Select **Format Media**.
6. Select **IBM Flash Adapter Disk**.
A + should appear next to the disk.
7. Press F7.
8. Select **Format without Certify**.
9. Select **Yes**.

After the device driver is installed, verify that the Flash storage adapter is available in the system. For instructions, see “Verifying the storage device availability in an AIX system or logical partition” on page 197.

Formatting the device in a Linux VM:

Learn how to format the IBM Flash Adapter 90 (PCIe2 0.9TB) device in a Linux virtual machine (VM).

Important: If you format the device, the data on the device will be destroyed. Ensure that you back up the data before you format the device.

To format the installed or replaced Flash adapter by using the `rs_format` utility, complete the following steps:

1. Log in as root user.
2. On the command line of the Linux session, type `rs_format`, and then press Enter.

The following screen is displayed:

```
# rs_format

Operating on device: /dev/rsxx0

* WARNING *

This utility is data destructive. Backup all data before proceeding.

Are you sure you want to continue? Enter 'Yes' to confirm: Yes
```

3. Type `Yes`, and then press Enter.

The following screen is displayed after the device is formatted:

```
Operating on device: /dev/rsxx0
```

```
* WARNING *
```

```
This utility is data destructive. Backup all data before proceeding.
```

```
Are you sure you want to continue? Enter 'Yes' to confirm: Yes
```

```
Formatting DONE
```

```
Format successful
```

After the device driver is installed, verify that the Flash storage adapter is available in the system. For instructions, see “Verifying the storage device availability in a Linux VM” on page 197.

Using the IBM Flash Adapter 90 (PCIe2 0.9TB)

Find information about using the IBM Flash Adapter 90 (PCIe2 0.9TB) PCIe Flash storage device in a system that is running the AIX or Linux operating system.

After you verify that the installed IBM Flash Adapter 90 (PCIe2 0.9TB) is ready for use, you can use the device as a disk storage device.

You can find information about mirroring the FC ES09 adapters by using the Logical Volume Manager (LVM) in the AIX Logical Volume Manager mirrors configuration requirements topic.

The `rs_info` Utility for the IBM Flash adapter 90 (PCIe2 0.9TB)

Learn how to install and use the `rs_info` utility to get information about the state and condition of the IBM Flash Adapter 90 (PCIe2 0.9TB).

The `rs_info` utility provides information about the state and condition of the IBM Flash adapter.

Choose from the following options that are based on the operating system that controls the adapter:

- “Verifying whether the `rs_info` utility is installed in an AIX system or an AIX logical partition”
- “Verifying whether the `rs_info` utility is installed in a Linux system or Linux virtual machine” on page 200
- “Installing the `rs_info` utility in an AIX system or an AIX logical partition” on page 200
- “Installing the `rs_info` utility in a Linux system or Linux virtual machine” on page 200
- “Running the `rs_info` utility in an AIX system or an AIX logical partition” on page 202
- “Running the `rs_info` utility in a Linux system or Linux virtual machine” on page 205
- “The `rs_info` utility fields” on page 207

Verifying whether the `rs_info` utility is installed in an AIX system or an AIX logical partition:

Learn to verify whether the `rs_info` utility is installed in an AIX system or an AIX logical partition.

1. Log in as root user.
2. Run the following command:

```
which /usr/lpp/diagnostics/bin/rs_info
```

- If the `rs_info` utility is installed, the following screen is displayed:

```
# which /usr/lpp/diagnostics/bin/rs_info
/usr/lpp/diagnostics/bin/rs_info
```

- If the **rs_info** utility is not installed, the following screen is displayed:

```
# which /usr/lpp/diagnostics/bin/rs_info
which: 0652-140 Cannot find /usr/lpp/diagnostics/bin/rs_info
```

Next, you can choose to do one of the following actions:

- If the **rs_info** utility is installed, you can run the **rs_info** utility. For instructions, see “Running the **rs_info** utility in an AIX system or an AIX logical partition” on page 202.
- If the **rs_info** utility is not installed, you can install the **rs_info** utility. For instructions, see “Installing the **rs_info** utility in an AIX system or an AIX logical partition.”

Verifying whether the **rs_info** utility is installed in a Linux system or Linux virtual machine:

Learn to verify whether the **rs_info** utility is installed in a Linux virtual machine (VM).

1. Log in as root user.
2. On the command line of the Linux session, type `which /usr/bin/rs_info`, and then press Enter.
 - If the **rs_info** utility is installed, the following screen is displayed:

```
## which /usr/bin/rs_info
/usr/bin/rs_info
```

- If the **rs_info** utility is not installed, the following screen is displayed:

```
# which /usr/bin/rs_info
/usr/bin/which: no rs_info in (/usr/bin)
```

Next, you can choose to do one of the following actions:

- If the **rs_info** utility is installed, you can run the **rs_info** utility. For instructions, see “Running the **rs_info** utility in a Linux system or Linux virtual machine” on page 205.
- If the **rs_info** utility is not installed, you can install the **rs_info** utility. For instructions, see “Installing the **rs_info** utility in a Linux system or Linux virtual machine.”

Installing the **rs_info** utility in an AIX system or an AIX logical partition:

Learn how to install the **rs_info** utility in an AIX system or an AIX logical partition.

The **rs_info** utility is installed by using the Rational Portfolio Manager (RPM) device driver. For instructions to install the device driver in an AIX system or an AIX logical partition, see “Installing the device driver in an AIX system or logical partition” on page 196.

Installing the **rs_info** utility in a Linux system or Linux virtual machine:

Learn to install the **rs_info** utility in a Linux virtual machine (VM).

The **rs_info** is installed by using the **rsxx-utils** package from the Yum repository.

To install the **rsxx-utils** package, complete the following steps:

1. Log in as root user.
2. On the command line of the Linux session, type `yum install rsxx-utils` and then press Enter. The following screen is displayed:

```
Loaded plugins: refresh-packagekit, security
Setting up Install Process
Resolving Dependencies
--> Running transaction check
  ---> Package rsxx-utils.ppc64 0:4.0.2.2487-1.e16 will be installed
--> Finished Dependency Resolution

Dependencies Resolved

=====
Package           Arch      Version           Repository         Size
=====
Installing:
rsxx-utils        ppc64    4.0.2.2487-1.e16  IBM_Power_Tools  330 k

Transaction Summary
=====
Install          1 Package(s)

Total download size: 330 k
Installed size: 741 k
Is this ok [y/N]:
```

3. Press Y, and then press Enter. The following screen is displayed, which indicates that the installation of the **rsxx-utils** package is complete:

```

Is this ok [y/N]: y
Downloading Packages:
rsxx-utils-4.0.2.2487-1.e16.ppc64.rpm          | 330 kB    00:00
Running rpm_check_debug
Running Transaction Test
Transaction Test Succeeded
Running Transaction
Installing : rsxx-utils-4.0.2.2487-1.e16.ppc64      1/1
Verifying  : rsxx-utils-4.0.2.2487-1.e16.ppc64      1/1

Installed:
rsxx-utils.ppc64 0:4.0.2.2487-1.e16

Complete!

```

Next, you can verify whether the **rs_info** utility has installed correctly. For instructions, see “Verifying whether the **rs_info** utility is installed in a Linux system or Linux virtual machine” on page 200.

You can also run the **rs_info** command to view the details of the IBM Flash adapters that are available in the system. For instructions, see “Running the **rs_info** utility in a Linux system or Linux virtual machine” on page 205.

Running the **rs_info** utility in an AIX system or an AIX logical partition:

Learn to run the **rs_info** utility in an AIX system or an AIX logical partition and understand the output.

The **rs_info** utility can be run on the PCIe Flash Storage adapters that are available in an AIX system or an AIX logical partition, but do not work on defined storage adapters.

To identify the available storage adapters and then run the **rs_info** utility, complete the following steps:

1. Run the following command to determine the available storage adapters:

```
lsdev -Cc disk | grep "Flash Adapter"
```

An output similar to the following screen is displayed, which shows the available disks:

```

# lsdev -Cc disk | grep "Flash Adapter"
hdisk1 Defined    07-00-01 IBM Flash Adapter Disk
hdisk2 Available 07-00-01 IBM Flash Adapter Disk
hdisk3 Defined    08-00-01 IBM Flash Adapter Disk

```

Where, **hdisk2** is the only available IBM Flash Adapter.

2. To run the **rs_info** utility on the available storage adapter, run the following command:

```
/usr/lpp/diagnostics/bin/rs_info
```

An output similar to the following screen is displayed, which shows the available disks:

```
# /opt/freeware/bin/rs_info
Please choose from the following or 'all':
1) /dev/hdisk1
2) /dev/hdisk2
3) /dev/hdisk3
?
```

Where, hdisk2 is the only available IBM Flash adapter.

3. Select the number that is associated with the disk for which you want to run the **rs_info** utility, or enter all if you want to select all the IBM Flash Adapters that are available to the system. If you select 2 an output similar to the following screen is displayed:

```
/dev/rsxx0
Device File: /dev/rsxx0
Part Number: 00AF044
FRU Number: 00AF045
CCIN: 578A
EC: H48566L
Firmware Level: 07_08768
Serial: YL10WP0R1EE4
Aux Serial: N/A
Card State: Good
Presented Capacity: 901939986432 Bytes
Physical Capacity: 1374389534720 Bytes
Board Temperature: 41.5 *C
Board Current: 01.555A
Board Voltage: 12.350V
Board Power: 19.204W
Capacitor Voltage: 09.229V
Powerloss Protection: True
Total Board Runtime: 216:10:11:20
Flash Type: Toshiba eMLC 256 Gb
Flash Page Size: 8192 Bytes
Flash Sector Size: 4096 Bytes
Flash Health State: Good
Flash Health %: 98%
Flash Wear Health: 100%
Bad Planes FPGA 0: 0
Bad Planes FPGA 1: 0
Bad Planes FPGA 2: 0
Bad Planes FPGA 3: 0
Factory Bad Blocks: 2222
Runtime Bad Blocks: 843
Total Bad Blocks: 3065
Flash User Writes (4k): 9730409781
Flash Moves (4k): 4629735275
Flash Total Writes (4k): 15955716728
```

For information about the fields that are displayed in the output, see “The **rs_info** utility fields” on page 207.

Running the **rs_info** utility in a Linux system or Linux virtual machine:

Learn to run the **rs_info** utility in a Linux system or Linux virtual machine and understand the output.

The **rs_info** utility can be run on the PCIe Flash Storage adapters that are available in the Linux operating system or Linux logical partition, but do not work on defined storage adapters.

To identify the available storage adapters and then run the **rs_info** utility, complete the following steps:

1. Log in as root user.
2. Run the following command:

```
/usr/bin/rs_info
```

An output similar to the following screen is displayed:

```
# /usr/bin/rs_info
Please choose from the following or 'all':
1) /dev/rsxx0
2) /dev/rsxx1
?
```

3. Select the number that is associated with the disk for which you want to run the **rs_info** utility, or enter `all` if you want to select all the IBM Flash Adapters that are available to the system. An output similar to the following screen is displayed:

```
/dev/rsxx0
Device File: /dev/rsxx0
Part Number: 00AF044
FRU Number: 00AF045
CCIN: 578A
EC: H48566L
Firmware Level: 07_08768
Serial: YL10WP0R1EE4
Aux Serial: N/A
Card State: Good
Presented Capacity: 901939986432 Bytes
Physical Capacity: 1374389534720 Bytes
Board Temperature: 41.5 *C
Board Current: 01.555A
Board Voltage: 12.350V
Board Power: 19.204W
Capacitor Voltage: 09.229V
Powerloss Protection: True
Total Board Runtime: 216:10:11:20
Flash Type: Toshiba eMLC 256 Gb
Flash Page Size: 8192 Bytes
Flash Sector Size: 4096 Bytes
Flash Health State: Good
Flash Health %: 98%
Flash Wear Health: 100%
Bad Planes FPGA 0: 0
Bad Planes FPGA 1: 0
Bad Planes FPGA 2: 0
Bad Planes FPGA 3: 0
Factory Bad Blocks: 2222
Runtime Bad Blocks: 843
Total Bad Blocks: 3065
Flash User Writes (4k): 9730409781
Flash Moves (4k): 4629735275
Flash Total Writes (4k): 15955716728
```

For information about the fields that are displayed in the output, see “The **rs_info** utility fields.”

The **rs_info** utility fields:

Find the description and details about the fields that are displayed in the **rs_info** output when the **rs_info** utility is run for the IBM Flash Adapter 90 (PCIe2 0.9TB) installed in the system or virtual machine.

Table 50 provides the description and details of the fields in the **rs_info** utility output.

*Table 50. The **rs_info** utility fields*

Field	Description
Device File	The device file that is assigned by the operating system in which the IBM Flash Adapter is installed.
Part Number	The part number of the IBM Flash Adapters.
FRU Number	The FRU number of the IBM Flash Adapters.
CCIN	The CCIN number of the IBM Flash Adapters.
EC	The EC number of the IBM Flash Adapter.
Firmware Level	The current firmware version that is running on the card.
Serial	The serial number of the IBM Flash Adapter.
Aux Serial	The serial number of the auxiliary boards that are located in the IBM Flash Adapter. There are no auxiliary boards that are located in the IBM Flash Adapter. Therefore, this field is displayed as N/A.
Card State	The state of the card. The different states follow: <ul style="list-style-type: none"> • Shutdown • Starting • Formatting • Uninitialized • Good • Shutting Down • Fault • Read Only Fault • dStroying • Unknown
Presented Capacity	The capacity as viewed by the operating system.
Physical Capacity	The full capacity of the flash on the IBM Flash Adapter, that is 1.2 Terabyte (TB). The extra 300 GB is used by the Flash adapter when bad flash blocks form in the flash storage, or during Redundant Array of Independent Disks (RAID) protection.
Board Temperature	The temperature on the card.
Board Current®	The current drawn by the card.
Board Voltage	The voltage across the card.
Board Power	The amount of power used on the card.
Capacitor Voltage	The voltage across the capacitors that are located on the card.
Powerloss Protection	Displays True if capacitors are located on the card, and displays as False if capacitors are not located on the card.
Total Board Runtime	The total time for which the card is powered on through out the life of the card.
Flash Type	The specific type of flash that is used on the IBM Flash Adapter.

Table 50. The `rs_info` utility fields (continued)

Field	Description
Flash Page Size	The size of each individual page in the flash.
Flash Sector Size	The size of each sector in the flash.
Flash Health State	The represents the health of the flash. The states follow: <ul style="list-style-type: none"> • Good • Warn
Flash Health %	The reported total health, in percentage, of the flash on the card.
Flash Wear Health	The health of the flash on the card displayed as a percentage.
Bad Planes FPGA X	The number of reported bad planes on field-programmable gate array (FPGA) X.
Factory Bad Blocks	The number of bad blocks that are detected during manufacturing.
Runtime Bad Blocks	The number of bad blocks that occurred during the use of the card.
Total Bad Blocks	The sum of the factory bad blocks and the runtime bad blocks.
Flash User Writes (4k)	The number of writes that are issued from the host.
Flash Moves (4k)	The number of moves (writes) during flashcard garbage-collection.
Flash Total Writes (4k)	The total number of writes to the adapter, including host writes, garbage-collection, moves, and RAID protection.

Maintaining the rechargeable battery on the 57B7, 57CF, 574E, and 572F/575C SAS adapters

Learn about the rechargeable battery maintenance tasks that include displaying rechargeable battery information, forcing a rechargeable battery error, and replacing the rechargeable cache battery pack.

Attention: Use these procedures only if directed from an isolation procedure or a maintenance analysis procedure (MAP).

The following list provides references to information about maintaining the rechargeable battery on the SAS adapters for systems or logical partition that run on the AIX, IBM i, or Linux operating systems:

- For information about maintaining the rechargeable battery for systems that run on the AIX operating system, see *Maintaining the rechargeable battery on the 57B7, 57CF, 574E, and 572F/575C SAS adapters*.
- For information about maintaining the rechargeable battery for systems that run on the Linux operating system, see *Rechargeable battery maintenance*.
- For information about maintaining the rechargeable battery for systems that run on the IBM i operating system, see *Rechargeable battery maintenance*.

Replacing SCSI RAID disk-controller cache battery packs

Learn how to remove or replace the cache battery from its controller.

Replacing this feature is a customer task. You can perform this task yourself, or contact an authorized service provider to perform the task for you. You might be charged a fee by the authorized service provider for this service.

To complete the procedures for the adapters, you might also need to use removal and replacement procedures for PCI adapters.

Replacing the cache battery pack on the 571B adapter

Learn how to replace the cache battery pack on the controller.

The following procedure describes how to replace a cache battery pack on the PCI-X DDR Dual Channel Ultra320 SCSI RAID adapter, CCIN 571B. The following feature codes apply to the 571B adapter.

Feature	CCIN	Description
0658 1913 5737 5776	571B	PCI-X DDR Dual Channel Ultra320 SCSI RAID adapter

Replacing this feature is a customer task. You can perform this task yourself, or contact an authorized service provider to perform the task for you. You might be charged a fee by the authorized service provider for this service.

Important: Removing the cache battery with the system or partition already in a powered-off state might result in the loss of customer data. If the system has been powered off *prior* to the battery service action, you *must* IPL to DST and continue this procedure *before* replacing the battery.

For information about replacing the cache battery pack on an AIX system or partition, see the *PCI-X SCSI RAID Controller Reference Guide for AIX* in the IBM(r) AIX Information Center.

For information about replacing the cache battery pack on a Linux system or partition, see the *PCI-X SCSI RAID Controller Reference Guide for Linux*. This guide is available from the SCSI PCI Adapters web page.

To replace the cache battery pack on the 571B adapter using the IBM i operating system, complete the following steps:

Note: To complete this procedure using i, you do not need to power off the system.

1. Ensure that the cache battery pack is in an error state before replacing it. This action will prevent possible data loss by ensuring that all cache data is written to disk before battery replacement. To force the cache battery pack into an error state, do the following steps on the system or partition that is using the 571B:
 - a. Be sure that you are signed on to the system with at least service level authority.
 - b. On the command line, type `strsst` and press Enter.
 - c. On the System Service Tools (SST) Sign On display, type your service tools user ID and service tools password. Press Enter.
 - d. On the System Service Tools (SST) display, select **Start a Service Tool**. Press Enter.
 - e. On the Start a Service Tool display, select **Hardware Service Manager**. Press Enter.
 - f. On the hardware Service Manager display, select **Work with resources containing cache battery packs**. Press Enter.
 - g. On the Work with Resources containing Cache Battery Packs display, select **Force battery pack into error state** for the I/O card. Press Enter.
 - h. On the Force Battery Packs Into Error State display, verify that the correct I/O adapter has been selected, and press the function key that confirms your choice.
 - i. Return to the Work with Resources containing Cache Battery Packs display and select **Display battery information**. Then verify that the **Battery pack can be safely replaced** field indicates yes. If it does not indicate yes, contact your next level of support before continuing this procedure.
2. Remove the 571B from its PCI slot:
3. Replace the cache battery pack by performing the following steps:

CAUTION:

The battery is a lithium ion battery. To avoid possible explosion, do not burn. Exchange only with the IBM-approved part. Recycle or discard the battery as instructed by local regulations. In the United States, IBM has a process for the collection of this battery. For information, call 1-800-426-4333. Have the IBM part number for the battery unit available when you call. (C007)

Attention:

- Attach a wrist strap to an unpainted metal surface of your hardware to prevent electrostatic discharge (ESD) from damaging your hardware.
 - When using a wrist strap, follow all electrical safety procedures. A wrist strap is for static control. It does not increase or decrease your risk of receiving electric shock when using or working on electrical equipment.
 - If you do not have a wrist strap, just prior to removing the product from ESD packaging and installing or replacing hardware, touch an unpainted metal surface of the system for a minimum of 5 seconds.
- a. Unplug the battery connector **B** from its connector in the adapter. Squeeze the retaining latch while gently pulling on the plug. The plug connects to the board in only one way so that it cannot be inserted incorrectly during the replacement procedure.
 - b. Locate the two plastic rivets **C** that hold the cache battery pack in place. From the back of the adapter, remove the two pins **D** that are installed inside of the rivets.

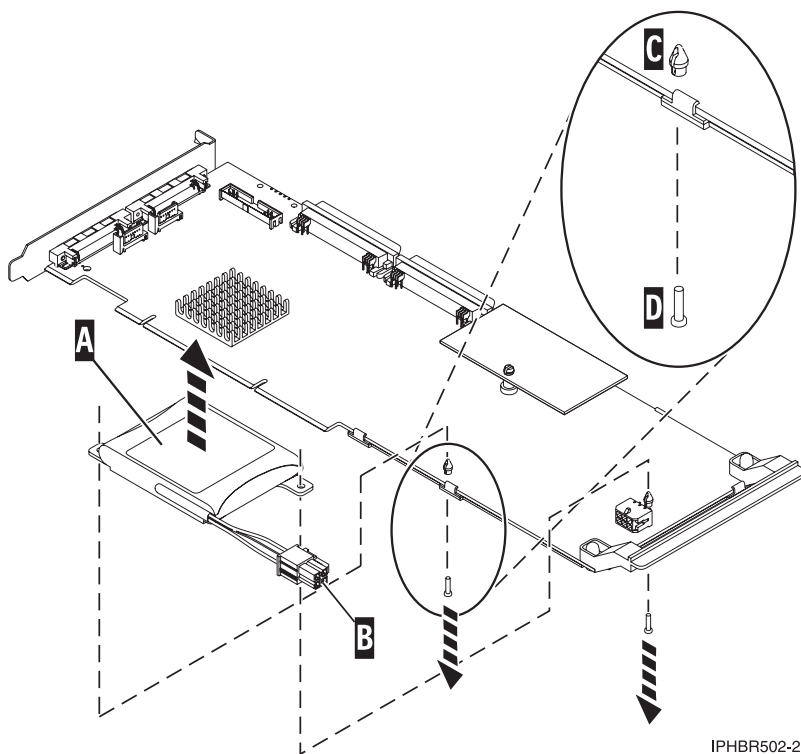

4. Release the push rivets **C** that secure the battery assembly to the adapter, and push the rivets through the back of the adapter. Remove the battery pack **A** from the adapter. If the rivets **C** cannot be pushed through the back of the adapter, go to step 4a.

Note: Ensure that the cache battery pack is disconnected for at least 60 seconds before connecting the new battery. This is the minimum amount of time needed for the card to recognize that the battery has been replaced.

If the rivets **C** cannot be pushed through the back of the adapter, follow these steps to push the rivets out with a ballpoint pen:

- a. Locate a retractable-ballpoint pen.

Note: A medium-sized retractable-ballpoint pen is preferred or an equivalent item with a small opening can be used. The small opening must be large enough so the pen (or equivalent) will go around the tip of the rivet, but small enough that it does not slide over the rivet and make contact with the battery assembly bracket.

- b. Slide the card off the edge of the work area just enough so rivet **C** can be pushed out of the back of the adapter.
 - c. Hold the pen with the ballpoint retracted, place the pen on top of rivet **C**, and gently push straight down until rivet **C** pushes out.
 - d. Repeat Steps 4b and 4c for the other rivet **C**.
 - e. Remove the cache battery pack **A** from the adapter.
 - f. Turn the adapter over and push the rivets **C** back into the adapter.
5. Install the new battery pack **A** onto the push rivets **C** of the adapter.
 6. Reinsert the pins **D** into the rivets on the back of the card.

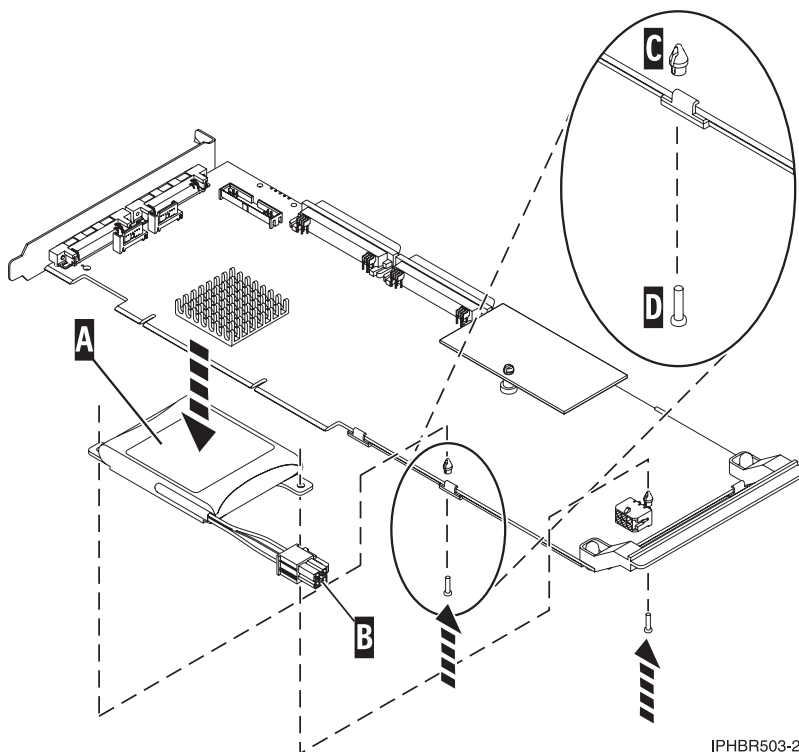

7. Connect the cache battery pack connector **B** to the adapter. The plug connects to the adapter in only one way, so it cannot be inserted incorrectly.
8. Reinstall the adapter.
9. Verify that the part is correctly installed.

Replacing the cache battery pack on the 571F and 575B adapters

You might need to replace the cache battery pack. Use the procedure in this section to perform this task.

This procedure describes how to replace the cache battery pack on the PCI-X DDR double wide quad channel Ultra 320 SCSI RAID adapter with auxiliary write cache, CCIN 571F (controller) and 575B (cache). The following feature codes apply to this double-wide adapter.

Feature	CCIN	Description
0650 0651 5739 5746 5778 5781 5782	571F 575B	PCI-X DDR double wide quad channel Ultra 320 SCSI RAID adapter with auxiliary write cache

Note: The cache battery for both the 571F adapter and the 575B adapter is contained in the single battery FRU that is physically located on the 575B auxiliary write cache adapter. The functions of forcing the battery pack into an error state and starting IOA cache on either adapter in the card set will result in the same functions automatically being performed on the other adapter in the card set.

Replacing this feature is a customer task. You can perform this task yourself, or contact an authorized service provider to perform the task for you. You might be charged a fee by the authorized service provider for this service.

Important: Removing the cache battery with the system or partition already in a powered-off state might result in the loss of customer data. If the system has been powered off *prior* to the battery service action, you *must* IPL to DST and continue this procedure *before* replacing the battery.

For information about replacing the cache battery pack on an AIX system or partition, see the *PCI-X SCSI RAID Controller Reference Guide for AIX* in the IBM(r) AIX Information Center.

For information about replacing the cache battery pack on a Linux system or partition, see the *PCI-X SCSI RAID Controller Reference Guide for Linux*. This guide is available from the SCSI PCI Adapters web page.

To replace the 571F adapter or 575B cache battery pack using the IBM i operating system, complete the following procedure:

Note: To complete these procedures, *do not* power off the adapter or power off the system or partition. The cache battery on these adapters is designed to be replaced concurrently.

1. Ensure that the cache battery pack is in an error state before replacing it. This action will prevent possible data loss by ensuring that all cache data is written to disk before battery replacement. To force the cache battery pack into an error state, do the following steps on the system or partition that is using the adapter:
 - a. Be sure that you are signed on to the system with at least service level authority.
 - b. On the command line, type `strsst`. Press Enter.
 - c. On the System Service Tools (SST) Sign On display, type your service tools user ID and service tools password. Press Enter.
2. Does the system or partition have i Version 5 Release 4 or later?
 - **Yes:** Continue with the next step.
 - **No:** Go to step 4.
3. On the System Service Tools (SST) display, select **Start a Service Tool**. Press Enter.
 - a. On the Start a Service Tool display, select **Hardware Service Manager**. Press Enter.
 - b. On the hardware Service Manager display, select **Work with resources containing cache battery packs**. Press Enter.
 - c. On the Work with Resources containing Cache Battery Packs display, select **Force battery pack into error state for the I/O card**. Press Enter.

- d. On the Force Battery Packs Into Error State display, verify that the correct I/O adapter has been selected, and press the function key that confirms your choice.
 - e. Return to the Work with Resources containing Cache Battery Packs display and select **Display battery information** and verify that the **Battery pack can be safely replaced** field indicates yes. If it does not indicate yes, contact your next level of support before continuing this procedure.
 - f. Continue with step 5.
4. On the System Service Tools (SST) display, select **Start a Service Tool**. Press Enter.
 - a. Select **Display/Alter/Dump**.
 - b. Select **Display/Alter storage**.
 - c. Select **Licensed Internal Code (LIC) data**.
 - d. Select **Advanced Analysis**.
 - e. Select the **BATTERY INFO** command.
 - f. On the Specify Advanced Analysis Options display, type **-LIST** in the **Options** field. Press Enter.
 - g. Find and note the resource name of the card you are working with.

Note: You can safely replace the cache battery pack when the display lists *yes* next to **Battery pack can be safely replaced**.

- h. Return to the Specify Advanced Analysis Options display. Type **-Force -IOA xxxx** where *xxxx* is the card resource name that you are working with and noted in the previous step. Press Enter.
 - i. Follow the directions on the display to confirm forcing the cache battery pack into an error state.
 - j. Return to the Specify Advanced Analysis Options display. Type **-LIST -IOA xxxx**, where *xxxx* is the card resource name that you are working with. Press Enter. The **Can be Safely Replaced** field should indicate yes.
5. Replace the cache battery pack by performing the following steps:

CAUTION:

The battery is a lithium ion battery. To avoid possible explosion, do not burn. Exchange only with the IBM-approved part. Recycle or discard the battery as instructed by local regulations. In the United States, IBM has a process for the collection of this battery. For information, call 1-800-426-4333. Have the IBM part number for the battery unit available when you call. (C007)

Attention:

- Attach a wrist strap to an unpainted metal surface of your hardware to prevent electrostatic discharge (ESD) from damaging your hardware.
 - When using a wrist strap, follow all electrical safety procedures. A wrist strap is for static control. It does not increase or decrease your risk of receiving electric shock when using or working on electrical equipment.
 - If you do not have a wrist strap, just prior to removing the product from ESD packaging and installing or replacing hardware, touch an unpainted metal surface of the system for a minimum of 5 seconds.
- a. Identify the correct adapter.
 - b. Locate the metal cover **A** that contains the cache battery pack. Pull out the push rivet **B** to release the metal cover **A**.

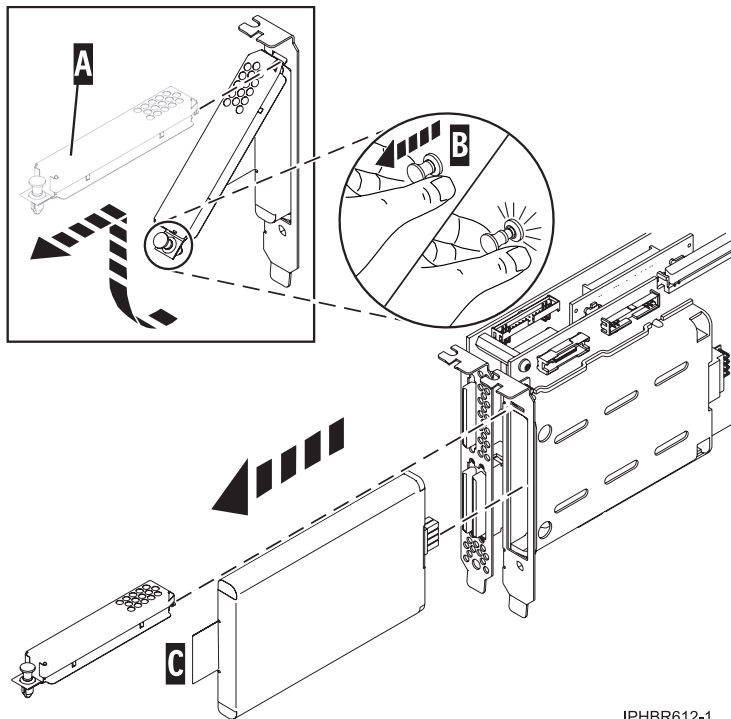

IPHBR612-1

6. Remove the cache battery pack by grasping the tab **C** and removing the battery from the adapter.
7. Install the new cache battery pack into the adapter, ensuring that the cache battery pack is seated correctly in its socket.
8. Replace metal cover **A** and push in on the push rivet **B** to secure the cover.
9. Does the system or partition have IBM i Version 5 Release 4, or later?
 - **Yes:** Continue with the next step.
 - **No:** Go to step 12.
10. Return to the Work with Resources containing Cache Battery Packs display and select the **Start IOA cache**. Press Enter.
11. Verify the Cache was started message is received. This ends the procedure.
12. Return to the Specify Advanced Analysis Options display and type `-START -IOA xxxx` where `xxxx` is the card resource name that you are working with.
13. Ensure that you get the message Cache started on IOA.

Replacing the cache battery pack on the 571E, 574F, 2780, or 5708 adapters

Learn how to replace the cache battery pack.

This procedure describes how to replace the cache battery pack on the adapters listed in the following table

Feature	CCIN	Description
5582	571E	PCI-X DDR Quad Channel Ultra 320 SCSI RAID adapter with an auxiliary-write cache IOA
5583	574F	
0627	2780	PCI-X Ultra4 RAID disk-controller
2780		

Feature	CCIN	Description
0641	2780	PCI-X Ultra4 RAID disk-controller with an auxiliary-write cache IOA
5590	574F	
5580	2780	PCI-X Ultra4 RAID disk-controller auxiliary-write cache IOA
	5708	
0649	571E	PCI-X DDR Quad Channel Ultra 320 SCSI RAID adapter
5738		
5777		

Replacing this feature is a customer task. You can perform this task yourself, or contact an authorized service provider to perform the task for you. You might be charged a fee by the authorized service provider for this service.

Important: Removing the cache battery with the system or partition already in a powered-off state might result in the loss of customer data. If the system has been powered off *prior* to the battery service action, you *must* IPL to DST and continue this procedure *before* replacing the battery.

Notes:

- The 0649 is not supported by the IBM i operating system.
- The 5708 is not supported by the IBM i operating system.

For information about replacing the cache battery pack on an AIX system or partition, see the *PCI-X SCSI RAID Controller Reference Guide for AIX* in the IBM(r) AIX Information Center.

For information about replacing the cache battery pack on a Linux system or partition, see the *PCI-X SCSI RAID Controller Reference Guide for Linux*. This guide is available from the SCSI PCI Adapters web page.

Note: To complete these procedures, do not power off the adapter or power off the system or partition. The cache battery on these adapters is designed to be replaced concurrently.

To replace the cache battery pack using the IBM i operating system, complete the following procedure:

1. Ensure that the cache battery pack is in an error state before replacing it. This action will prevent possible data loss by ensuring that all cache data is written to disk before battery replacement. To force the cache battery pack into an error state, do the following steps on the system or partition that is using the adapters:
 - a. Be sure that you are signed on to the system with at least service level authority.
 - b. On the command line, type `strsst`. Press Enter.
 - c. Type your service tools user ID and service tools password on the System Service Tools (SST) Sign On display. Press Enter.
2. Is the system or partition running have i Version 5 Release 4, or later?
 - **Yes:** Continue with the next step.
 - **No:** Go to step 4.
3. On the System Service Tools (SST) display, select **Start a Service Tool**. Press Enter.
 - a. On the Start a Service Tool display, select **Hardware Service Manager**. Press Enter.
 - b. On the hardware Service Manager display, select **Work with resources containing cache battery packs**. Press Enter.

- c. On the Work with Resources containing Cache Battery Packs display, select **Force battery pack into error state for the I/O card**. Press Enter.
 - d. On the Force Battery Packs Into Error State display, verify that the correct I/O adapter has been selected and press the function key that confirms your choice.
 - e. Return to the Work with Resources containing Cache Battery Packs display and select **Display battery information**. Verify that the **Battery pack can be safely replaced** field indicates yes. If it does not indicate yes, contact your next level of support before continuing this procedure.
 - f. Continue with step 5.
4. On the System Service Tools (SST) display, select **Start a Service Tool**. Press Enter.
 - a. Select **Display/Alter/Dump**.
 - b. Select **Display/Alter storage**.
 - c. Select **Licensed Internal Code (LIC) data**.
 - d. Select **Advanced Analysis**.
 - e. Select the **BATTERY INFO** command.
 - f. On the Specify Advanced Analysis Options display, type **-LIST** in the **Options** field. Press Enter.
 - g. Find and note the resource name of the adapter you are working with.

Note: You can safely replace the cache battery pack when the display lists *yes* next to **Battery pack can be safely replaced**.

- h. Return to the Specify Advanced Analysis Options display. Type **-Force -IOA xxxx** where *xxxx* is the card resource name that you are working with and noted in the previous step. Press Enter.
 - i. Follow the directions on the display to confirm forcing the cache battery pack into an error state.
 - j. Return to the Specify Advanced Analysis Options display. Type **-LIST -IOA xxxx**, where *xxxx* is the card resource name that you are working with. Press Enter. The **Battery pack can be safely replaced** field indicates yes.
5. Replace the cache battery pack by performing the following steps:

CAUTION:

The battery is a lithium ion battery. To avoid possible explosion, do not burn. Exchange only with the IBM-approved part. Recycle or discard the battery as instructed by local regulations. In the United States, IBM has a process for the collection of this battery. For information, call 1-800-426-4333. Have the IBM part number for the battery unit available when you call. (C007)

Attention:

- Attach a wrist strap to an unpainted metal surface of your hardware to prevent electrostatic discharge (ESD) from damaging your hardware.
 - When using a wrist strap, follow all electrical safety procedures. A wrist strap is for static control. It does not increase or decrease your risk of receiving electric shock when using or working on electrical equipment.
 - If you do not have a wrist strap, just prior to removing the product from ESD packaging and installing or replacing hardware, touch an unpainted metal surface of the system for a minimum of 5 seconds.
- a. Identify the correct adapter.
 - b. Locate the metal cover **A** that contains the battery pack. Pull out the push rivet to release the metal cover **A**.

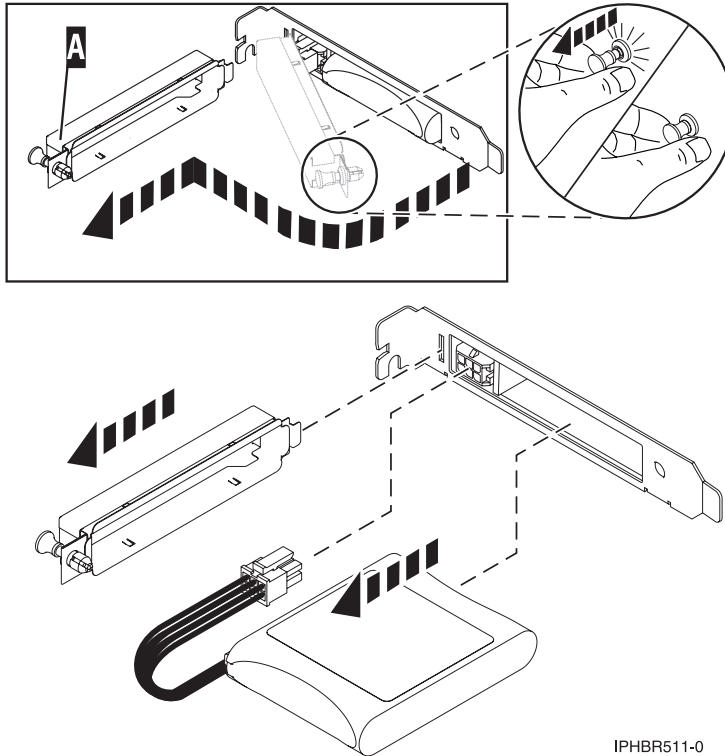

IPHBR511-0

6. Disconnect the plug that connects the cache battery pack and the adapter. Squeeze the retaining latch while gently pulling on the plug. The plug connects to the board in only one way, so it cannot be inserted incorrectly during the replacement procedure.
7. Remove the cache battery pack by gently pulling it out of the adapter.
8. Install the new cache battery pack.
9. Connect the cache battery pack plug to the card. The plug connects to the card in only one way so that it cannot be inserted incorrectly during the replacement procedure.
10. Replace metal cover A and push in the push rivet to secure the cover to the adapter.
11. Does the system or partition have i Version 5 Release 4 or later?
 - **Yes:** Continue with the next step.
 - **No:** Go to step 14.
12. Return to the Work with Resources containing Cache Battery Packs display and select the **Start IOA cache**. Press Enter.
13. Verify the Cache was started message is received. This step ends the procedure.
14. Return to the Specify Advanced Analysis Options display and type `-START -IOA xxxx` where `xxxx` is the card resource name that you are working with.
15. Ensure that the Cache started on IOA message is received.

Replacing a battery pack

Follow these guidelines before you replace the battery pack.

Note: When replacing the cache battery pack, the battery must be disconnected for at least 60 seconds before you connect the new battery. This duration is the minimum amount of time that is needed for the card to recognize that the battery has been replaced.

Note: The battery is a lithium ion battery. To avoid possible explosion, do not burn. Exchange only with the IBM-approved part. Recycle or discard the battery as instructed by local regulations. In the United

States, IBM has a process for the collection of this battery. For information, call 1-800-426-4333. Have the IBM part number for the battery unit available when you call.

Attention: To prevent data loss, if the cache battery pack is not already in the error state, follow the steps described in Forcing a rechargeable battery error before proceeding. If the cache data present LED is flashing, do not replace the cache battery pack or data will be lost. See the feature descriptions and the figures in the following sections to determine if your adapter has a cache data present LED and the location of the LED.

Attention: Static electricity can damage this device and your system unit. To avoid damage, keep this device in its antistatic protective bag until you are ready to install it. To reduce the possibility of electrostatic discharge, read the following precautions:

- Limit your movement. Movement can cause static electricity to build up around you.
- Handle the device carefully, holding it by its edges or its frame.
- Do not touch solder joints, pins, or exposed printed circuitry.
- Do not leave the device where others can handle and possibly damage the device.
- While the device is still in its antistatic package, touch it to an unpainted metal part of the system unit for at least 2 seconds. (This duration drains static electricity from the package and from your body.)
- Remove the device from its package and install it directly into your system unit without setting it down. If it is necessary to set the device down, place it on its static-protective package. (If your device is a controller, place it component-side up.) Do not place the device on your system unit cover or on a metal table.
- Take additional care when handling devices during cold weather, as heating reduces indoor humidity and increases static electricity.

Replacing a 572B nonconcurrent maintainable battery pack

Use this procedure to replace the nonconcurrent maintainable battery pack on adapter type CCIN 572B.

Attention: Before continuing with this procedure, determine that it is safe to replace the cache battery pack. See Displaying rechargeable battery information. It is safe to replace the cache battery pack when **Yes** is displayed next to **Battery pack can be safely replaced**.

To replace a nonconcurrent maintainable battery pack, complete the following steps:

1. Remove the controller from the system. See your system documentation for instructions.
2. Place the controller on a surface that is electrostatic-discharge protected.
3. Unplug the battery connector (**B**) from its connector on the adapter, squeezing the retaining latch while gently pulling on the plug. The plug connects to the board in only one way, so it cannot be inserted incorrectly during the replacement procedure.

Note: Ensure that the cache battery pack is disconnected for at least 60 seconds before connecting the new battery. This duration is the minimum amount of time needed for the adapter to recognize that the battery has been replaced.

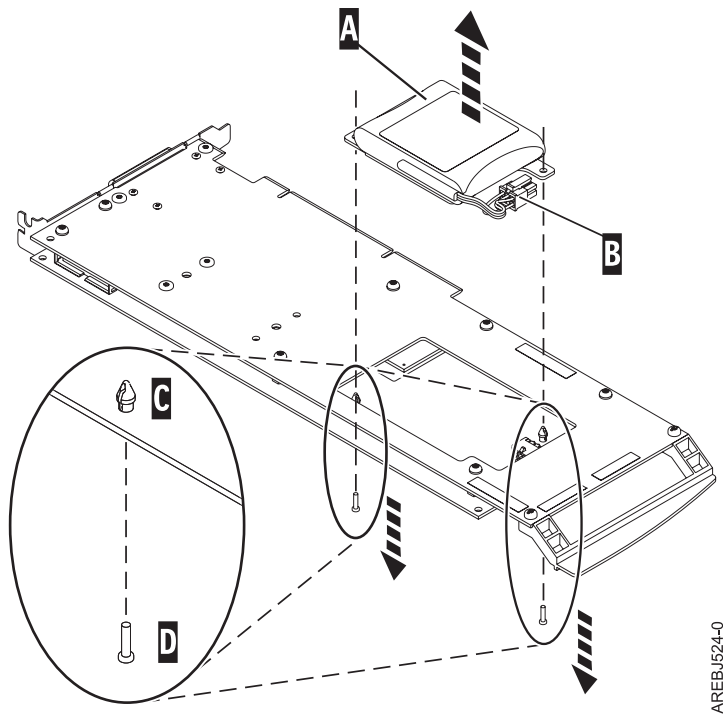

- (A) Cache battery pack
- (B) Battery connector
- (C) Plastic rivet
- (D) Plastic pin

Figure 65. Removing the cache battery

4. Locate the two plastic rivets (C) that hold the cache battery pack in place. From the back of the adapter, remove the two pins (D) that are inserted inside of the rivets.
5. Release the rivets (C) that secure the battery assembly to the adapter. Press the rivets through the back of the adapter and remove the battery pack (A) from the adapter. If the rivets (C) cannot be pressed through the back of the adapter, follow these steps to press out the rivets with a ballpoint pen:
 - a. Locate a retractable ballpoint pen.

Note: A medium-sized retractable ballpoint pen is preferred, or an equivalent item with a small opening can be used. The small opening must be large enough so that the pen (or equivalent) can go around the tip of the rivet, but small enough that it does not slide over the rivet and contact the battery assembly bracket.

- b. Slide the card off the edge of the work area enough so rivet (C) can be pressed out of the back of the adapter.
- c. Hold the pen with the ballpoint retracted, place the pen on top of rivet (C), and gently press straight down until rivet (C) presses out.
- d. Repeat steps 5b and 5c for the other rivet (C).
- e. Remove the cache battery pack (A) from the adapter.
- f. Turn the adapter over and press the rivets (C) back into the adapter.
6. Install the new battery pack. (A) onto the press rivets (C) of the adapter.
7. Reinsert the pins (D) into the rivets from the back of the adapter.
8. Connect the cache battery pack connector (B) to the adapter. The plug connects to the adapter in only one way, so it cannot be inserted incorrectly.

9. Reinstall the adapter.

Replacing a 572F/575C card set concurrent maintainable battery pack

Use this procedure to replace the concurrent maintainable battery pack on adapter type CCIN 572F/575C card set.

Attention: Before you continue with this procedure, determine that it is safe to replace the cache battery pack. See “Maintaining the rechargeable battery on the 57B7, 57CF, 574E, and 572F/575C SAS adapters” on page 208. It is safe to replace the cache battery pack when Yes is displayed next to Battery pack can be safely replaced. If the cache data present LED is flashing, do not replace the cache battery pack or the cache data is lost. See the feature comparison tables for PCIe and PCI-X cards for the LED details and its location.

To replace a 572F/575C concurrent maintainable battery pack, complete the following steps:

1. Using the following illustration to locate the battery components, locate the metal cover (A) that holds the battery pack. Pull out on the push-rivet (B) to release the metal cover (A).

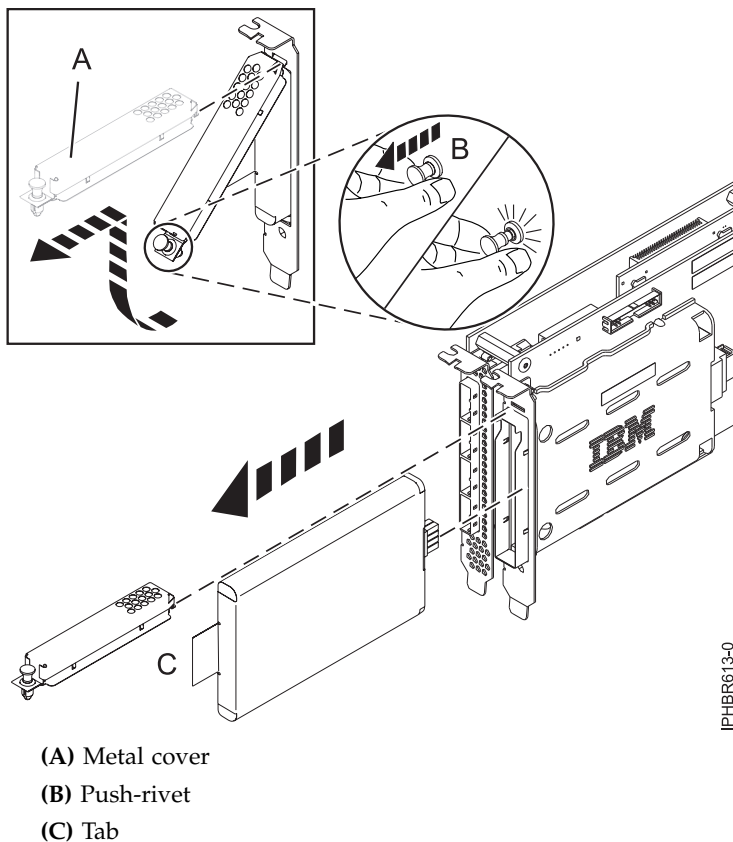

Figure 66. Replacing the 572F/575C cache battery

2. Remove the battery unit by pulling on tab (C).

Note: Ensure that the cache battery pack is disconnected for at least 60 seconds before you connect the new battery. This duration is the minimum amount of time that is needed for the card to recognize that the battery has been replaced.

3. Install the new cache battery pack by reversing this procedure. Ensure that the replacement cache battery pack is fully seated.
4. Restart the write cache of the adapter by completing the following steps:

- a. Return to the **Work with Resources containing Cache Battery Packs display** and select the **Start IOA cache**. Press Enter.
- b. Ensure that you get the message Cache was started.

Replacing a 57B7 concurrent maintainable battery pack

Use this procedure to replace the concurrent maintainable battery pack on adapter type CCIN 57B7.

Attention: Before continuing with this procedure, determine that it is safe to replace the cache battery pack, see “Maintaining the rechargeable battery on the 57B7, 57CF, 574E, and 572F/575C SAS adapters” on page 208. It is safe to replace the cache battery pack when Yes is displayed next to Battery pack can be safely replaced. If the cache data present LED is flashing, do not replace the cache battery pack or the cache data is lost. See the feature comparison tables for PCIe and PCI-X cards and the following figures to determine whether your adapter has a cache data present LED and its location.

To replace a 57B7 concurrent maintainable battery pack, complete the following steps:

1. Using the following illustration to locate the battery components, verify that the cache data present LED (C) is not flashing. If it is flashing, do not continue; return to “Maintaining the rechargeable battery on the 57B7, 57CF, 574E, and 572F/575C SAS adapters” on page 208.

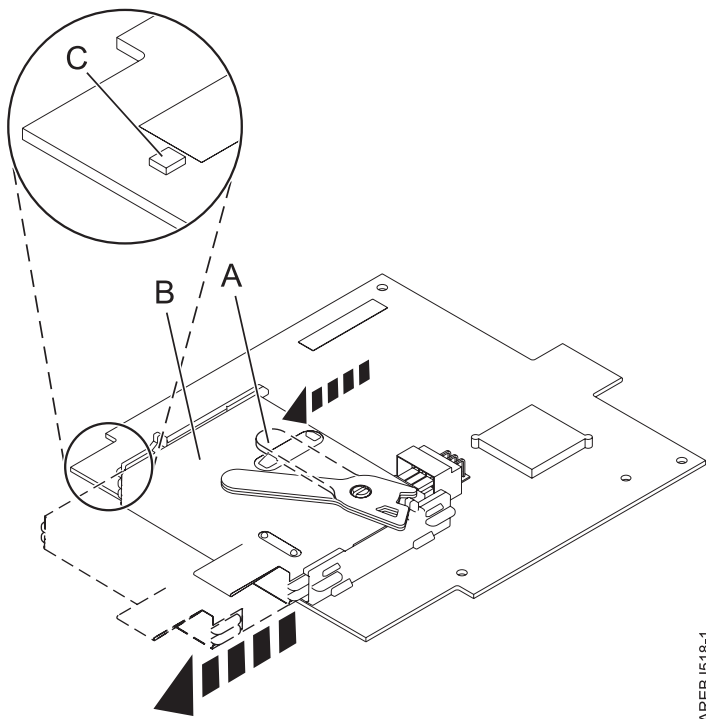

- (A) Cache battery lever
- (B) Cache battery pack
- (C) Cache present LED

Figure 67. Removing the 57B7 cache battery

2. Move the cache battery lever (A) away from the connector to disengage the battery from the connector.

Note: Hold the RAID auxiliary cache card with one hand to ensure it stays in the connector while you use the other hand to move the lever and remove the battery from the card.

3. Continue to slide the cache battery pack out of the mounting guides and remove it from the controller.

Note: Ensure that the cache battery pack is disconnected for at least 60 seconds before you connect the new battery. This duration is the minimum amount of time that is needed for the card to recognize that the battery has been replaced.

4. Using the following illustration to locate the battery components, move the lever to the unlatched position (away from the connector).

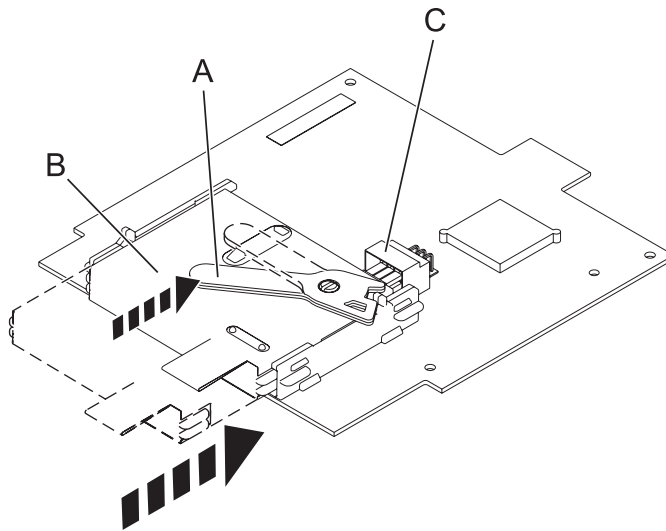

AREBU519-0

- (A) Cache battery lever
- (B) Cache battery pack
- (C) Cache battery connector

Figure 68. Replacing the 57B7 cache battery

5. Slide the new cache battery pack into the mounting guides on the controller until it is seated in the battery connector.
6. After the battery is seated in the connector, move the lever to the latched position to fully seat the battery into the connector.
7. Restart the write cache of the adapter by completing the following steps:
 - a. Navigate to the **IBM SAS Disk Array Manager** by using the steps in Using the Disk Array Manager.
 - b. Select **Diagnostics and Recovery > Controller Rechargeable Battery Maintenance > Start Adapter Cache Option**.
 - c. Select the controller with the battery you just replaced and then press **Enter**.

Replacing a 57CF cache battery pack

Learn how to replace the 57CF cache battery pack.

To replace the 57CF cache battery pack, see Removing and replacing the 175 MB cache RAID - dual IOA enablement card cache battery pack. Removing and replacing the 175 MB cache RAID - dual IOA enablement card cache battery pack.

Replacing a 574E concurrent maintainable battery pack

Use this procedure to replace the concurrent maintainable battery pack on adapter type CCIN 574E.

Attention: Before continuing with this procedure, determine that it is safe to replace the cache battery pack. See “Maintaining the rechargeable battery on the 57B7, 57CF, 574E, and 572F/575C SAS adapters” on page 208. It is safe to replace the cache battery pack when Yes is displayed next to Battery pack can be safely replaced. If the cache data present LED is flashing, do not replace the cache battery pack or data will be lost. See the feature comparison tables for PCIe and PCI-X cards and the following figures to determine whether your adapter has a cache data present LED and its location.

To replace a 574E concurrent maintainable battery pack, complete the following steps:

1. Using the following illustration to locate the battery components, verify that the cache data present LED (C) is not flashing. If it is flashing, do not continue; return to **Forcing a rechargeable battery error**.

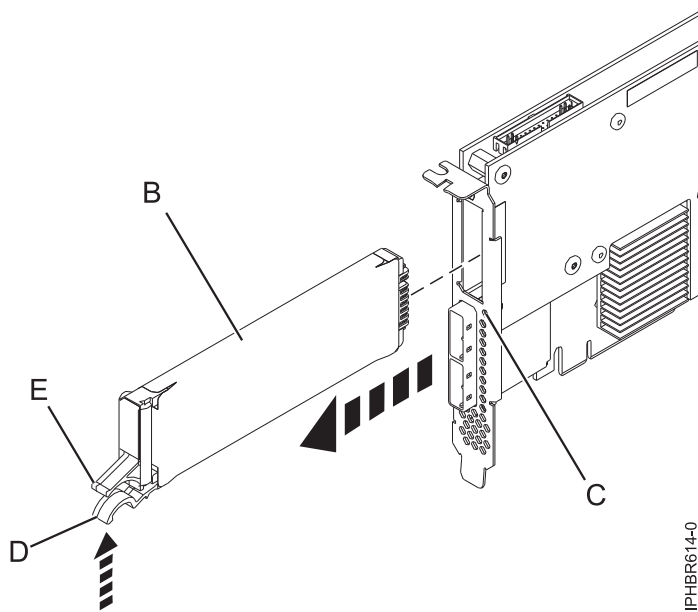

- (B) Cache battery pack
- (C) Cache data present LED
- (D) Cache battery tab
- (E) Cache battery tab

Figure 69. Replacing the 574E cache battery

2. Squeeze tab (D) against tab (E) to disengage the battery retaining tab, pull out the cache battery pack (B), and remove it from the controller.

Important: Use caution when squeezing tabs because the plastic parts can be fragile.

Note: Ensure that the cache battery pack is disconnected for at least 60 seconds before you connect the new battery. This duration is the minimum amount of time that is needed for the card to recognize that the battery has been replaced.

3. Install the new cache battery pack by reversing this procedure. Ensure that the replacement cache battery back is fully seated.
4. Restart the write cache of the adapter by completing the following steps:
 - a. Return to the **Work with Resources containing Cache Battery Packs display** and select the **Start IOA cache**. Press Enter.
 - b. Ensure that you get the message Cache was started.

Displaying rechargeable battery information

Learn about the procedure to display information about the rechargeable battery in the RAID controller for your operating system.

The following list provide the procedures to display rechargeable battery information in the SAS RAID adapters for the system or logical partition that is running on the AIX, IBM i, or Linux operating systems:

- For information about displaying the rechargeable battery information for the system running on the AIX operating system, see *Displaying rechargeable battery information*.
- For information about displaying the rechargeable battery information for the system running on the Linux operating system, see *Displaying rechargeable battery information*.
- For information about displaying the rechargeable battery information for the system running on the IBM i operating system, see *Displaying rechargeable battery information*.

Installing the AIX device driver software

Learn how to install the AIX device driver software for a PCI adapter.

If you are installing the AIX operating system at this time, install the adapter before you install the operating system. When you install AIX, the adapter device driver is automatically installed and the following procedure does not apply to your situation.

If you are installing only the device driver for a PCI adapter, perform these steps:

1. Log in to the system unit as root user.
2. Insert the media containing the device driver software (for example, the CD) into the media device. If your system does not have a CD-ROM drive, refer to your system documentation for performing a Network Installation Management (NIM) installation.
3. Type the following System Management Interface Tool (SMIT) fast path command: `smit devinst`.
4. Press Enter. The Install Additional Device Software window highlights the `INPUT device /` directory for software option.
5. Type the name of the input device that you are using, or press F4 to select the input device from a list.
6. Press Enter. The Install Additional Device Software window highlights the `SOFTWARE to install` option.
7. Press F4 to select List.
8. Type `/` to display the Find window.
9. Type the device package name, and press Enter. The system finds and highlights this device driver software.
10. Press F7 to select the highlighted device driver software, and press Enter. The `INSTALL ADDITIONAL DEVICE SOFTWARE` window is displayed. The entry fields are automatically updated.
11. Press Enter to accept the information. The `ARE YOU SURE` window is displayed.
12. Press Enter to accept the information. The `COMMAND STATUS` window is displayed.
 - The message `RUNNING` is highlighted to indicate that the installation and configuration command is in progress.

- When RUNNING changes to OK, scroll to the bottom of the page and locate the installation summary.
- After a successful installation, SUCCESS displayed in the Result column of the installation summary at the bottom of the page.

13. Remove the installation media from the drive.

14. Press F10 to exit SMIT.

Verifying the AIX device driver software

Learn how to verify the AIX device driver is installed for a PCI adapter.

To verify that the AIX device driver for an adapter is installed, do the following steps:

1. If necessary, log in as root user.
2. At the command line, type `lslpp -l devices.xxxxxxxxx` where `xxxxxxxxxx` is the device package name.
3. Press Enter.

If the adapter device driver is installed, the following is an example of the data that is displayed on the window.

File set	Level	State	Description
Path: /usr/lib/objrepos devices.xxxxxxxxx	5.3.8.0	COMMITTED	<i>Adapter name</i> software

Verify that the file sets are installed at the AIX version level you are running. Level 5.3.8.0 is an example. If no data is displayed on your screen, the adapter device driver was not installed correctly. Try reinstalling the driver.

Notices

This information was developed for products and services offered in the U.S.A.

The manufacturer may not offer the products, services, or features discussed in this document in other countries. Consult the manufacturer's representative for information on the products and services currently available in your area. Any reference to the manufacturer's product, program, or service is not intended to state or imply that only that product, program, or service may be used. Any functionally equivalent product, program, or service that does not infringe any intellectual property right of the manufacturer may be used instead. However, it is the user's responsibility to evaluate and verify the operation of any product, program, or service.

The manufacturer may have patents or pending patent applications covering subject matter described in this document. The furnishing of this document does not grant you any license to these patents. You can send license inquiries, in writing, to the manufacturer.

The following paragraph does not apply to the United Kingdom or any other country where such provisions are inconsistent with local law: THIS PUBLICATION IS PROVIDED "AS IS" WITHOUT WARRANTY OF ANY KIND, EITHER EXPRESS OR IMPLIED, INCLUDING, BUT NOT LIMITED TO, THE IMPLIED WARRANTIES OF NON-INFRINGEMENT, MERCHANTABILITY OR FITNESS FOR A PARTICULAR PURPOSE. Some states do not allow disclaimer of express or implied warranties in certain transactions, therefore, this statement may not apply to you.

This information could include technical inaccuracies or typographical errors. Changes are periodically made to the information herein; these changes will be incorporated in new editions of the publication. The manufacturer may make improvements and/or changes in the product(s) and/or the program(s) described in this publication at any time without notice.

Any references in this information to websites not owned by the manufacturer are provided for convenience only and do not in any manner serve as an endorsement of those websites. The materials at those websites are not part of the materials for this product and use of those websites is at your own risk.

The manufacturer may use or distribute any of the information you supply in any way it believes appropriate without incurring any obligation to you.

Any performance data contained herein was determined in a controlled environment. Therefore, the results obtained in other operating environments may vary significantly. Some measurements may have been made on development-level systems and there is no guarantee that these measurements will be the same on generally available systems. Furthermore, some measurements may have been estimated through extrapolation. Actual results may vary. Users of this document should verify the applicable data for their specific environment.

Information concerning products not produced by this manufacturer was obtained from the suppliers of those products, their published announcements or other publicly available sources. This manufacturer has not tested those products and cannot confirm the accuracy of performance, compatibility or any other claims related to products not produced by this manufacturer. Questions on the capabilities of products not produced by this manufacturer should be addressed to the suppliers of those products.

All statements regarding the manufacturer's future direction or intent are subject to change or withdrawal without notice, and represent goals and objectives only.

The manufacturer's prices shown are the manufacturer's suggested retail prices, are current and are subject to change without notice. Dealer prices may vary.

This information is for planning purposes only. The information herein is subject to change before the products described become available.

This information contains examples of data and reports used in daily business operations. To illustrate them as completely as possible, the examples include the names of individuals, companies, brands, and products. All of these names are fictitious and any similarity to the names and addresses used by an actual business enterprise is entirely coincidental.

If you are viewing this information in softcopy, the photographs and color illustrations may not appear.

The drawings and specifications contained herein shall not be reproduced in whole or in part without the written permission of the manufacturer.

The manufacturer has prepared this information for use with the specific machines indicated. The manufacturer makes no representations that it is suitable for any other purpose.

The manufacturer's computer systems contain mechanisms designed to reduce the possibility of undetected data corruption or loss. This risk, however, cannot be eliminated. Users who experience unplanned outages, system failures, power fluctuations or outages, or component failures must verify the accuracy of operations performed and data saved or transmitted by the system at or near the time of the outage or failure. In addition, users must establish procedures to ensure that there is independent data verification before relying on such data in sensitive or critical operations. Users should periodically check the manufacturer's support websites for updated information and fixes applicable to the system and related software.

Homologation statement

This product may not be certified in your country for connection by any means whatsoever to interfaces of public telecommunications networks. Further certification may be required by law prior to making any such connection. Contact an IBM representative or reseller for any questions.

Trademarks

IBM, the IBM logo, and ibm.com are trademarks or registered trademarks of International Business Machines Corp., registered in many jurisdictions worldwide. Other product and service names might be trademarks of IBM or other companies. A current list of IBM trademarks is available on the web at www.ibm.com/legal/copytrade.shtml.

INFINIBAND, InfiniBand Trade Association, and the INFINIBAND design marks are trademarks and/or service marks of the INFINIBAND Trade Association.

Intel, Intel logo, Intel Inside, Intel Inside logo, Intel Centrino, Intel Centrino logo, Celeron, Intel Xeon, Intel SpeedStep, Itanium, and Pentium are trademarks or registered trademarks of Intel Corporation or its subsidiaries in the United States and other countries.

Linux is a registered trademark of Linus Torvalds in the United States, other countries, or both.

Red Hat, the Red Hat "Shadow Man" logo, and all Red Hat-based trademarks and logos are trademarks or registered trademarks of Red Hat, Inc., in the United States and other countries.

Electronic emission notices

When attaching a monitor to the equipment, you must use the designated monitor cable and any interference suppression devices supplied with the monitor.

Class A Notices

The following Class A statements apply to the IBM servers that contain the POWER7[®] processor and its features unless designated as electromagnetic compatibility (EMC) Class B in the feature information.

Federal Communications Commission (FCC) statement

Note: This equipment has been tested and found to comply with the limits for a Class A digital device, pursuant to Part 15 of the FCC Rules. These limits are designed to provide reasonable protection against harmful interference when the equipment is operated in a commercial environment. This equipment generates, uses, and can radiate radio frequency energy and, if not installed and used in accordance with the instruction manual, may cause harmful interference to radio communications. Operation of this equipment in a residential area is likely to cause harmful interference, in which case the user will be required to correct the interference at his own expense.

Properly shielded and grounded cables and connectors must be used in order to meet FCC emission limits. IBM is not responsible for any radio or television interference caused by using other than recommended cables and connectors or by unauthorized changes or modifications to this equipment. Unauthorized changes or modifications could void the user's authority to operate the equipment.

This device complies with Part 15 of the FCC rules. Operation is subject to the following two conditions: (1) this device may not cause harmful interference, and (2) this device must accept any interference received, including interference that may cause undesired operation.

Industry Canada Compliance Statement

This Class A digital apparatus complies with Canadian ICES-003.

Avis de conformité à la réglementation d'Industrie Canada

Cet appareil numérique de la classe A est conforme à la norme NMB-003 du Canada.

European Community Compliance Statement

This product is in conformity with the protection requirements of EU Council Directive 2004/108/EC on the approximation of the laws of the Member States relating to electromagnetic compatibility. IBM cannot accept responsibility for any failure to satisfy the protection requirements resulting from a non-recommended modification of the product, including the fitting of non-IBM option cards.

This product has been tested and found to comply with the limits for Class A Information Technology Equipment according to European Standard EN 55022. The limits for Class A equipment were derived for commercial and industrial environments to provide reasonable protection against interference with licensed communication equipment.

European Community contact:
IBM Deutschland GmbH
Technical Regulations, Department M372
IBM-Allee 1, 71139 Ehningen, Germany
Tele: +49 7032 15 2941
email: lugi@de.ibm.com

Warning: This is a Class A product. In a domestic environment, this product may cause radio interference, in which case the user may be required to take adequate measures.

VCCI Statement - Japan

この装置は、クラスA 情報技術装置です。この装置を家庭環境で使用すると電波妨害を引き起こすことがあります。この場合には使用者が適切な対策を講ずるよう要求されることがあります。

VCCI-A

The following is a summary of the VCCI Japanese statement in the box above:

This is a Class A product based on the standard of the VCCI Council. If this equipment is used in a domestic environment, radio interference may occur, in which case, the user may be required to take corrective actions.

Japanese Electronics and Information Technology Industries Association (JEITA) Confirmed Harmonics Guideline (products less than or equal to 20 A per phase)

高調波ガイドライン適合品

Japanese Electronics and Information Technology Industries Association (JEITA) Confirmed Harmonics Guideline with Modifications (products greater than 20 A per phase)

高調波ガイドライン準用品

Electromagnetic Interference (EMI) Statement - People's Republic of China

声 明

此为 A 级产品, 在生活环境中, 该产品可能会造成无线电干扰。在这种情况下, 可能需要用户对其干扰采取切实可行的措施。

Declaration: This is a Class A product. In a domestic environment this product may cause radio interference in which case the user may need to perform practical action.

Electromagnetic Interference (EMI) Statement - Taiwan

警告使用者：
這是甲類的資訊產品，在居住的環境中使用時，可能會造成射頻干擾，在這種情況下，使用者會被要求採取某些適當的對策。

The following is a summary of the EMI Taiwan statement above.

Warning: This is a Class A product. In a domestic environment this product may cause radio interference in which case the user will be required to take adequate measures.

IBM Taiwan Contact Information:

台灣IBM 產品服務聯絡方式：
台灣國際商業機器股份有限公司
台北市松仁路7號3樓
電話：0800-016-888

Electromagnetic Interference (EMI) Statement - Korea

이 기기는 업무용(A급)으로 전자파적합기기로서 판매자 또는 사용자는 이 점을 주의하시기 바라며, 가정외의 지역에서 사용하는 것을 목적으로 합니다.

Germany Compliance Statement

Deutschsprachiger EU Hinweis: Hinweis für Geräte der Klasse A EU-Richtlinie zur Elektromagnetischen Verträglichkeit

Dieses Produkt entspricht den Schutzanforderungen der EU-Richtlinie 2004/108/EG zur Angleichung der Rechtsvorschriften über die elektromagnetische Verträglichkeit in den EU-Mitgliedsstaaten und hält die Grenzwerte der EN 55022 Klasse A ein.

Um dieses sicherzustellen, sind die Geräte wie in den Handbüchern beschrieben zu installieren und zu betreiben. Des Weiteren dürfen auch nur von der IBM empfohlene Kabel angeschlossen werden. IBM übernimmt keine Verantwortung für die Einhaltung der Schutzanforderungen, wenn das Produkt ohne Zustimmung von IBM verändert bzw. wenn Erweiterungskomponenten von Fremdherstellern ohne Empfehlung von IBM gesteckt/eingebaut werden.

EN 55022 Klasse A Geräte müssen mit folgendem Warnhinweis versehen werden:
"Warnung: Dieses ist eine Einrichtung der Klasse A. Diese Einrichtung kann im Wohnbereich Funk-Störungen verursachen; in diesem Fall kann vom Betreiber verlangt werden, angemessene Maßnahmen zu ergreifen und dafür aufzukommen."

Deutschland: Einhaltung des Gesetzes über die elektromagnetische Verträglichkeit von Geräten

Dieses Produkt entspricht dem "Gesetz über die elektromagnetische Verträglichkeit von Geräten (EMVG)". Dies ist die Umsetzung der EU-Richtlinie 2004/108/EG in der Bundesrepublik Deutschland.

Zulassungsbescheinigung laut dem Deutschen Gesetz über die elektromagnetische Verträglichkeit von Geräten (EMVG) (bzw. der EMC EG Richtlinie 2004/108/EG) für Geräte der Klasse A

Dieses Gerät ist berechtigt, in Übereinstimmung mit dem Deutschen EMVG das EG-Konformitätszeichen - CE - zu führen.

Verantwortlich für die Einhaltung der EMV Vorschriften ist der Hersteller:
International Business Machines Corp.
New Orchard Road
Armonk, New York 10504
Tel: 914-499-1900

Der verantwortliche Ansprechpartner des Herstellers in der EU ist:
IBM Deutschland GmbH
Technical Regulations, Abteilung M372
IBM-Allee 1, 71139 Ehningen, Germany
Tel: +49 7032 15 2941
email: lugi@de.ibm.com

Generelle Informationen:

Das Gerät erfüllt die Schutzanforderungen nach EN 55024 und EN 55022 Klasse A.

Electromagnetic Interference (EMI) Statement - Russia

ВНИМАНИЕ! Настоящее изделие относится к классу А.
В жилых помещениях оно может создавать радиопомехи, для снижения которых необходимы дополнительные меры

Class B Notices

The following Class B statements apply to features designated as electromagnetic compatibility (EMC) Class B in the feature installation information.

Federal Communications Commission (FCC) statement

This equipment has been tested and found to comply with the limits for a Class B digital device, pursuant to Part 15 of the FCC Rules. These limits are designed to provide reasonable protection against harmful interference in a residential installation.

This equipment generates, uses, and can radiate radio frequency energy and, if not installed and used in accordance with the instructions, may cause harmful interference to radio communications. However, there is no guarantee that interference will not occur in a particular installation.

If this equipment does cause harmful interference to radio or television reception, which can be determined by turning the equipment off and on, the user is encouraged to try to correct the interference by one or more of the following measures:

- Reorient or relocate the receiving antenna.
- Increase the separation between the equipment and receiver.
- Connect the equipment into an outlet on a circuit different from that to which the receiver is connected.
- Consult an IBM-authorized dealer or service representative for help.

Properly shielded and grounded cables and connectors must be used in order to meet FCC emission limits. Proper cables and connectors are available from IBM-authorized dealers. IBM is not responsible for any radio or television interference caused by unauthorized changes or modifications to this equipment. Unauthorized changes or modifications could void the user's authority to operate this equipment.

This device complies with Part 15 of the FCC rules. Operation is subject to the following two conditions: (1) this device may not cause harmful interference, and (2) this device must accept any interference received, including interference that may cause undesired operation.

Industry Canada Compliance Statement

This Class B digital apparatus complies with Canadian ICES-003.

Avis de conformité à la réglementation d'Industrie Canada

Cet appareil numérique de la classe B est conforme à la norme NMB-003 du Canada.

European Community Compliance Statement

This product is in conformity with the protection requirements of EU Council Directive 2004/108/EC on the approximation of the laws of the Member States relating to electromagnetic compatibility. IBM cannot accept responsibility for any failure to satisfy the protection requirements resulting from a non-recommended modification of the product, including the fitting of non-IBM option cards.

This product has been tested and found to comply with the limits for Class B Information Technology Equipment according to European Standard EN 55022. The limits for Class B equipment were derived for typical residential environments to provide reasonable protection against interference with licensed communication equipment.

European Community contact:
IBM Deutschland GmbH
Technical Regulations, Department M372
IBM-Allee 1, 71139 Ehningen, Germany
Tele: +49 7032 15 2941
email: lugi@de.ibm.com

VCCI Statement - Japan

この装置は、クラスB情報技術装置です。この装置は、家庭環境で使用することを目的としていますが、この装置がラジオやテレビジョン受信機に近接して使用されると、受信障害を引き起こすことがあります。

取扱説明書に従って正しい取り扱いをして下さい。 VCCI-B

Japanese Electronics and Information Technology Industries Association (JEITA) Confirmed Harmonics Guideline (products less than or equal to 20 A per phase)

高調波ガイドライン適合品

Japanese Electronics and Information Technology Industries Association (JEITA) Confirmed Harmonics Guideline with Modifications (products greater than 20 A per phase)

高調波ガイドライン準用品

IBM Taiwan Contact Information

台灣IBM 產品服務聯絡方式：
台灣國際商業機器股份有限公司
台北市松仁路7號3樓
電話：0800-016-888

Electromagnetic Interference (EMI) Statement - Korea

이 기기는 가정용(B급)으로 전자파적합기기로서 주로 가정에서 사용하는 것을 목적으로 하며, 모든 지역에서 사용할 수 있습니다.

Germany Compliance Statement

Deutschsprachiger EU Hinweis: Hinweis für Geräte der Klasse B EU-Richtlinie zur Elektromagnetischen Verträglichkeit

Dieses Produkt entspricht den Schutzanforderungen der EU-Richtlinie 2004/108/EG zur Angleichung der Rechtsvorschriften über die elektromagnetische Verträglichkeit in den EU-Mitgliedsstaaten und hält die Grenzwerte der EN 55022 Klasse B ein.

Um dieses sicherzustellen, sind die Geräte wie in den Handbüchern beschrieben zu installieren und zu betreiben. Des Weiteren dürfen auch nur von der IBM empfohlene Kabel angeschlossen werden. IBM übernimmt keine Verantwortung für die Einhaltung der Schutzanforderungen, wenn das Produkt ohne Zustimmung von IBM verändert bzw. wenn Erweiterungskomponenten von Fremdherstellern ohne Empfehlung von IBM gesteckt/eingebaut werden.

Deutschland: Einhaltung des Gesetzes über die elektromagnetische Verträglichkeit von Geräten

Dieses Produkt entspricht dem "Gesetz über die elektromagnetische Verträglichkeit von Geräten (EMVG)". Dies ist die Umsetzung der EU-Richtlinie 2004/108/EG in der Bundesrepublik Deutschland.

Zulassungsbescheinigung laut dem Deutschen Gesetz über die elektromagnetische Verträglichkeit von Geräten (EMVG) (bzw. der EMC EG Richtlinie 2004/108/EG) für Geräte der Klasse B

Dieses Gerät ist berechtigt, in Übereinstimmung mit dem Deutschen EMVG das EG-Konformitätszeichen - CE - zu führen.

Verantwortlich für die Einhaltung der EMV Vorschriften ist der Hersteller:
International Business Machines Corp.
New Orchard Road
Armonk, New York 10504
Tel: 914-499-1900

Der verantwortliche Ansprechpartner des Herstellers in der EU ist:
IBM Deutschland GmbH
Technical Regulations, Abteilung M372
IBM-Allee 1, 71139 Ehningen, Germany
Tel: +49 7032 15 2941
email: lugi@de.ibm.com

Generelle Informationen:

Das Gerät erfüllt die Schutzanforderungen nach EN 55024 und EN 55022 Klasse B.

Terms and conditions

Permissions for the use of these publications are granted subject to the following terms and conditions.

Applicability: These terms and conditions are in addition to any terms of use for the IBM website.

Personal Use: You may reproduce these publications for your personal, noncommercial use provided that all proprietary notices are preserved. You may not distribute, display or make derivative works of these publications, or any portion thereof, without the express consent of IBM.

Commercial Use: You may reproduce, distribute and display these publications solely within your enterprise provided that all proprietary notices are preserved. You may not make derivative works of these publications, or reproduce, distribute or display these publications or any portion thereof outside your enterprise, without the express consent of IBM.

Rights: Except as expressly granted in this permission, no other permissions, licenses or rights are granted, either express or implied, to the Publications or any information, data, software or other intellectual property contained therein.

IBM reserves the right to withdraw the permissions granted herein whenever, in its discretion, the use of the publications is detrimental to its interest or, as determined by IBM, the above instructions are not being properly followed.

You may not download, export or re-export this information except in full compliance with all applicable laws and regulations, including all United States export laws and regulations.

IBM MAKES NO GUARANTEE ABOUT THE CONTENT OF THESE PUBLICATIONS. THE PUBLICATIONS ARE PROVIDED "AS-IS" AND WITHOUT WARRANTY OF ANY KIND, EITHER EXPRESSED OR IMPLIED, INCLUDING BUT NOT LIMITED TO IMPLIED WARRANTIES OF MERCHANTABILITY, NON-INFRINGEMENT, AND FITNESS FOR A PARTICULAR PURPOSE.



Printed in USA