

Power Systems

*Service information for the PCIe
storage enclosures*

IBM

Power Systems

*Service information for the PCIe
storage enclosures*



Note

Before using this information and the product it supports, read the information in "Safety notices" on page v, "Notices" on page 43, the *IBM Systems Safety Notices* manual, G229-9054, and the *IBM Environmental Notices and User Guide*, Z125-5823.

This edition applies to IBM Power Systems™ servers that contain the POWER7 processor and to all associated models.

© Copyright IBM Corporation 2012, 2013.

US Government Users Restricted Rights – Use, duplication or disclosure restricted by GSA ADP Schedule Contract with IBM Corp.

Contents

Safety notices	v
Service information for the PCIe storage enclosures	1
Overview of 5888 or EDR1 PCIe storage enclosure service	1
PCIe storage enclosure infrastructure	2
PCIe storage enclosure features	3
Cabling the PCIe storage enclosure	4
Cabling the 5888 PCIe storage enclosure to an 8202-E4C or 8205-E6C system	4
Cabling the EDR1 PCIe storage enclosure to an 8202-E4D or 8205-E6D system	9
Cabling the 5887 disk drive enclosure to an EDR1 PCIe storage enclosure that is attached to an 8202-E4D or 8205-E6D	14
Cabling the 5888 PCIe storage enclosure to an 8231-E1C or 8231-E2C system	15
Cabling the EDR1 PCIe storage enclosure to an 8231-E1D, 8231-E2D, or 8268-E1D system	18
Cabling the 5887 disk drive enclosure to an EDR1 PCIe storage enclosure that is attached to an 8231-E1D, 8231-E2D, or 8268-E1D	20
Cabling the EDR1 PCIe storage enclosure to an 8246-L2T system	20
Cabling the 5887 disk drive enclosure to an EDR1 PCIe storage enclosure that is attached to an 8246-L2T	22
Cabling the EDR1 PCIe storage enclosure to an 8248-L4T, 8408-E8D, or 9109-RMD system	23
Cabling the 5887 disk drive enclosure to an EDR1 PCIe storage enclosure that is attached to an 8248-L4T, 8408-E8D, or 9109-RMD	25
Cabling the EDR1 PCIe storage enclosure to an 8412-EAD, 9117-MMC, 9117-MMD, 9179-MHC, or 9179-MHD system	26
Cabling the 5887 disk drive enclosure to an EDR1 PCIe storage enclosure that is attached to an 8412-EAD, 9117-MMC, 9117-MMD, 9179-MHC, or 9179-MHD	31
Overview of problem determination	33
LED use for the 5888 or EDR1 PCIe storage enclosure	34
5888 or EDR1 PCIe storage enclosure light-emitting diode (LED) locations.	34
RAID controller location code	35
Determining the ERM location from the RAID controller location	36
Determining the ERM location from the RAID controller location when using AIX	36
Determining the ERM location from the RAID controller location when using IBM i	37
Determining the ERM location from the RAID controller location when using Linux	38
Updating microcode for PCIe storage enclosure components	39
FRUs for the 5888 or EDR1 PCIe storage enclosure	40
Identifying a SAS fabric FRU for the 5888 or EDR1 PCIe storage enclosure	40
Storage enclosure topology	41
Notices	43
Trademarks	44
Electronic emission notices	44
Class A Notices	44
Class B Notices	48
Terms and conditions	51

Safety notices

Safety notices may be printed throughout this guide:

- **DANGER** notices call attention to a situation that is potentially lethal or extremely hazardous to people.
- **CAUTION** notices call attention to a situation that is potentially hazardous to people because of some existing condition.
- **Attention** notices call attention to the possibility of damage to a program, device, system, or data.

World Trade safety information

Several countries require the safety information contained in product publications to be presented in their national languages. If this requirement applies to your country, safety information documentation is included in the publications package (such as in printed documentation, on DVD, or as part of the product) shipped with the product. The documentation contains the safety information in your national language with references to the U.S. English source. Before using a U.S. English publication to install, operate, or service this product, you must first become familiar with the related safety information documentation. You should also refer to the safety information documentation any time you do not clearly understand any safety information in the U.S. English publications.

Replacement or additional copies of safety information documentation can be obtained by calling the IBM Hotline at 1-800-300-8751.

German safety information

Das Produkt ist nicht für den Einsatz an Bildschirmarbeitsplätzen im Sinne § 2 der Bildschirmarbeitsverordnung geeignet.

Laser safety information

IBM® servers can use I/O cards or features that are fiber-optic based and that utilize lasers or LEDs.

Laser compliance

IBM servers may be installed inside or outside of an IT equipment rack.

DANGER

When working on or around the system, observe the following precautions:

Electrical voltage and current from power, telephone, and communication cables are hazardous. To avoid a shock hazard:

- Connect power to this unit only with the IBM provided power cord. Do not use the IBM provided power cord for any other product.
- Do not open or service any power supply assembly.
- Do not connect or disconnect any cables or perform installation, maintenance, or reconfiguration of this product during an electrical storm.
- The product might be equipped with multiple power cords. To remove all hazardous voltages, disconnect all power cords.
- Connect all power cords to a properly wired and grounded electrical outlet. Ensure that the outlet supplies proper voltage and phase rotation according to the system rating plate.
- Connect any equipment that will be attached to this product to properly wired outlets.
- When possible, use one hand only to connect or disconnect signal cables.
- Never turn on any equipment when there is evidence of fire, water, or structural damage.
- Disconnect the attached power cords, telecommunications systems, networks, and modems before you open the device covers, unless instructed otherwise in the installation and configuration procedures.
- Connect and disconnect cables as described in the following procedures when installing, moving, or opening covers on this product or attached devices.

To Disconnect:

1. Turn off everything (unless instructed otherwise).
2. Remove the power cords from the outlets.
3. Remove the signal cables from the connectors.
4. Remove all cables from the devices.

To Connect:

1. Turn off everything (unless instructed otherwise).
2. Attach all cables to the devices.
3. Attach the signal cables to the connectors.
4. Attach the power cords to the outlets.
5. Turn on the devices.

(D005)

DANGER

Observe the following precautions when working on or around your IT rack system:

- Heavy equipment—personal injury or equipment damage might result if mishandled.
- Always lower the leveling pads on the rack cabinet.
- Always install stabilizer brackets on the rack cabinet.
- To avoid hazardous conditions due to uneven mechanical loading, always install the heaviest devices in the bottom of the rack cabinet. Always install servers and optional devices starting from the bottom of the rack cabinet.
- Rack-mounted devices are not to be used as shelves or work spaces. Do not place objects on top of rack-mounted devices.



- Each rack cabinet might have more than one power cord. Be sure to disconnect all power cords in the rack cabinet when directed to disconnect power during servicing.
- Connect all devices installed in a rack cabinet to power devices installed in the same rack cabinet. Do not plug a power cord from a device installed in one rack cabinet into a power device installed in a different rack cabinet.
- An electrical outlet that is not correctly wired could place hazardous voltage on the metal parts of the system or the devices that attach to the system. It is the responsibility of the customer to ensure that the outlet is correctly wired and grounded to prevent an electrical shock.

CAUTION

- Do not install a unit in a rack where the internal rack ambient temperatures will exceed the manufacturer's recommended ambient temperature for all your rack-mounted devices.
- Do not install a unit in a rack where the air flow is compromised. Ensure that air flow is not blocked or reduced on any side, front, or back of a unit used for air flow through the unit.
- Consideration should be given to the connection of the equipment to the supply circuit so that overloading of the circuits does not compromise the supply wiring or overcurrent protection. To provide the correct power connection to a rack, refer to the rating labels located on the equipment in the rack to determine the total power requirement of the supply circuit.
- *(For sliding drawers.)* Do not pull out or install any drawer or feature if the rack stabilizer brackets are not attached to the rack. Do not pull out more than one drawer at a time. The rack might become unstable if you pull out more than one drawer at a time.
- *(For fixed drawers.)* This drawer is a fixed drawer and must not be moved for servicing unless specified by the manufacturer. Attempting to move the drawer partially or completely out of the rack might cause the rack to become unstable or cause the drawer to fall out of the rack.

(R001)

CAUTION:

Removing components from the upper positions in the rack cabinet improves rack stability during relocation. Follow these general guidelines whenever you relocate a populated rack cabinet within a room or building:

- Reduce the weight of the rack cabinet by removing equipment starting at the top of the rack cabinet. When possible, restore the rack cabinet to the configuration of the rack cabinet as you received it. If this configuration is not known, you must observe the following precautions:
 - Remove all devices in the 32U position and above.
 - Ensure that the heaviest devices are installed in the bottom of the rack cabinet.
 - Ensure that there are no empty U-levels between devices installed in the rack cabinet below the 32U level.
- If the rack cabinet you are relocating is part of a suite of rack cabinets, detach the rack cabinet from the suite.
- Inspect the route that you plan to take to eliminate potential hazards.
- Verify that the route that you choose can support the weight of the loaded rack cabinet. Refer to the documentation that comes with your rack cabinet for the weight of a loaded rack cabinet.
- Verify that all door openings are at least 760 x 230 mm (30 x 80 in.).
- Ensure that all devices, shelves, drawers, doors, and cables are secure.
- Ensure that the four leveling pads are raised to their highest position.
- Ensure that there is no stabilizer bracket installed on the rack cabinet during movement.
- Do not use a ramp inclined at more than 10 degrees.
- When the rack cabinet is in the new location, complete the following steps:
 - Lower the four leveling pads.
 - Install stabilizer brackets on the rack cabinet.
 - If you removed any devices from the rack cabinet, repopulate the rack cabinet from the lowest position to the highest position.
- If a long-distance relocation is required, restore the rack cabinet to the configuration of the rack cabinet as you received it. Pack the rack cabinet in the original packaging material, or equivalent. Also lower the leveling pads to raise the casters off of the pallet and bolt the rack cabinet to the pallet.

(R002)

(L001)



(L002)



(L003)

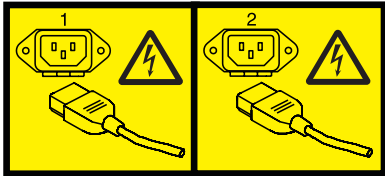

or



All lasers are certified in the U.S. to conform to the requirements of DHHS 21 CFR Subchapter J for class 1 laser products. Outside the U.S., they are certified to be in compliance with IEC 60825 as a class 1 laser product. Consult the label on each part for laser certification numbers and approval information.

CAUTION:

This product might contain one or more of the following devices: CD-ROM drive, DVD-ROM drive, DVD-RAM drive, or laser module, which are Class 1 laser products. Note the following information:

- Do not remove the covers. Removing the covers of the laser product could result in exposure to hazardous laser radiation. There are no serviceable parts inside the device.
- Use of the controls or adjustments or performance of procedures other than those specified herein might result in hazardous radiation exposure.

(C026)

CAUTION:

Data processing environments can contain equipment transmitting on system links with laser modules that operate at greater than Class 1 power levels. For this reason, never look into the end of an optical fiber cable or open receptacle. (C027)

CAUTION:

This product contains a Class 1M laser. Do not view directly with optical instruments. (C028)

CAUTION:

Some laser products contain an embedded Class 3A or Class 3B laser diode. Note the following information: laser radiation when open. Do not stare into the beam, do not view directly with optical instruments, and avoid direct exposure to the beam. (C030)

CAUTION:

The battery contains lithium. To avoid possible explosion, do not burn or charge the battery.

Do Not:

- ___ Throw or immerse into water
- ___ Heat to more than 100°C (212°F)
- ___ Repair or disassemble

Exchange only with the IBM-approved part. Recycle or discard the battery as instructed by local regulations. In the United States, IBM has a process for the collection of this battery. For information, call 1-800-426-4333. Have the IBM part number for the battery unit available when you call. (C003)

Power and cabling information for NEBS (Network Equipment-Building System) GR-1089-CORE

The following comments apply to the IBM servers that have been designated as conforming to NEBS (Network Equipment-Building System) GR-1089-CORE:

The equipment is suitable for installation in the following:

- Network telecommunications facilities
- Locations where the NEC (National Electrical Code) applies

The intrabuilding ports of this equipment are suitable for connection to intrabuilding or unexposed wiring or cabling only. The intrabuilding ports of this equipment *must not* be metallically connected to the interfaces that connect to the OSP (outside plant) or its wiring. These interfaces are designed for use as intrabuilding interfaces only (Type 2 or Type 4 ports as described in GR-1089-CORE) and require isolation from the exposed OSP cabling. The addition of primary protectors is not sufficient protection to connect these interfaces metallically to OSP wiring.

Note: All Ethernet cables must be shielded and grounded at both ends.

The ac-powered system does not require the use of an external surge protection device (SPD).

The dc-powered system employs an isolated DC return (DC-I) design. The DC battery return terminal *shall not* be connected to the chassis or frame ground.

Service information for the PCIe storage enclosures

This collection provides service information for the 5888 or EDR1 Peripheral Component Interconnect Express (PCIe) storage enclosure.

Overview of 5888 or EDR1 PCIe storage enclosure service

Find information to help you service the 5888 or EDR1 PCIe storage enclosure.



The IBM EXP30 Ultra SSD I/O Drawer (feature code 5888 and EDR1) is a 1.8-inch solid-state drive (SSD) optimized PCIe storage enclosure that is mounted in a 19-inch rack. It attaches to supported POWER7[®] processor-based systems by using PCI Express generation 2 (PCIe2) GX++ adapters and PCIe2 cables. The 5888 or EDR1 PCIe storage enclosure includes the following components:

- Redundant power supplies
- Redundant fans
- Two redundant, large cache PCIe2 serial-attached SCSI (SAS) redundant array of independent disks (RAID) controllers along with redundant SAS port expanders
- Up to 30 1.8-inch dual port SAS SSDs

The 5888 and EDR1 PCIe storage enclosures contain two redundant enclosure RAID modules (ERMs), which contain a SAS RAID controller, a SAS port expander, and a replaceable fan assembly. Two power supplies provide an N+1 redundant feature that allows one power supply to power the entire enclosure if the other power supply failed or is missing.

- The two power supplies have built-in fans.
- Fan speed is automatically adjusted, as needed, to ensure correct cooling temperatures of the enclosure even when a fan fails.

The SAS RAID controllers are always configured in a dual controller (dual storage I/O adapter) configuration. This configuration provides redundant access paths to the SAS devices and mirrored copies of cache data and parity update footprints. The dual controller configuration also allows for increased performance capability when multiple RAID arrays are used in an Active/Active configuration mode. The SAS RAID controllers support RAID 0, 10, 5, and 6 and the hot-spare function.

The 5888 or EDR1 PCIe storage enclosure is a one EIA unit drawer that is mounted in a 19-inch rack. It is designed for light path service with light-emitting diode (LED) indicators on the front and rear of the enclosure chassis. These chassis LED indicators provide status and fault information for the following components and conditions:

- Enclosure identification
- Enclosure power
- Enclosure fans
- ERMs
- Enclosure faults
- SSD activity and SSD fault or identification

The PCIe storage enclosure is designed for front and rear service, performed in place (that is not in a service position) except for the midplane field replaceable unit (FRU) replacement.

PCIe storage enclosure infrastructure

Learn how the 5888 or EDR1 PCIe storage enclosure is different from previous storage enclosures.

With previous IBM SAS storage enclosure models, connecting disk drives was accomplished by using individual components that were externally connected to each other:

- Storage enclosures
- Disk drive controllers
- SAS cables for multiple paths to devices and dedicated adapter-to-adapter connections

Figure 1 shows an example of a dual storage I/O adapter (IOA) solution by using externally connected components.

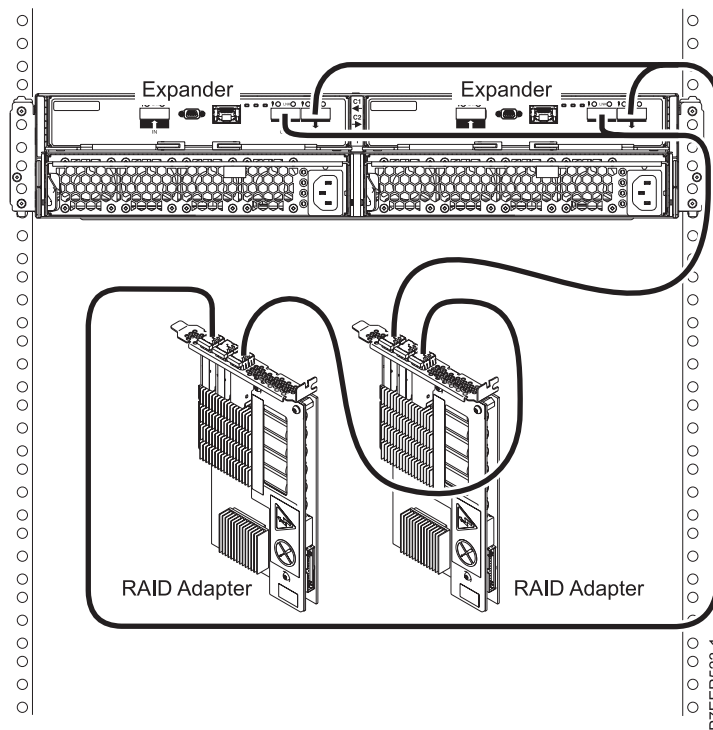

Figure 1. Dual storage IOA solution by using externally connected components

With the 5888 or EDR1 PCIe storage enclosures, all of the necessary components are integrated within the storage enclosure.

Figure 2 on page 3 shows a dual storage IOA solution that is integrated within the 5888 or EDR1 PCIe storage enclosure.

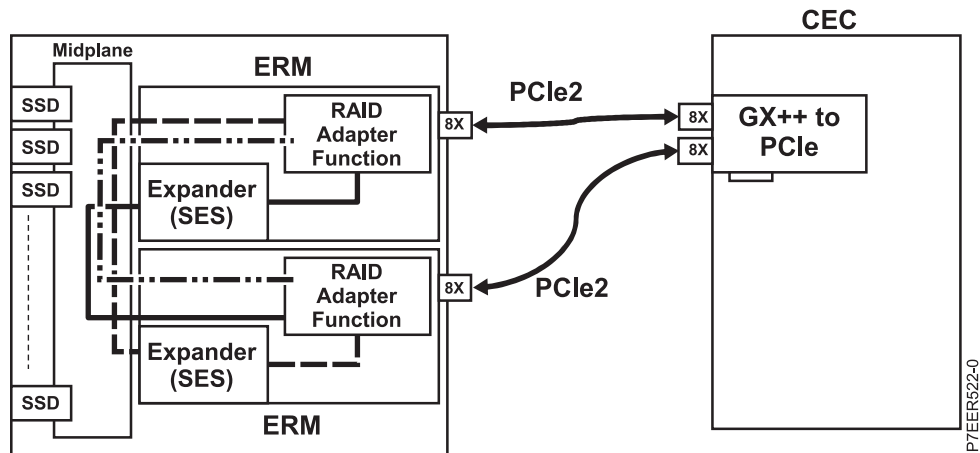

Figure 2. Dual storage IOA solution integrated within the 5888 or EDR1 PCIe storage enclosure

The following components and functions are integrated within the 5888 or EDR1 PCIe storage enclosure:

- The enclosure RAID module (ERM) contains the RAID adapter function and the expander function.
- The storage enclosure uses internal wiring to connect components with multiple redundant paths, eliminating the need for external SAS cables.
- A maximum of 30 1.5-inch solid-state drives (SSDs) may be installed in the storage enclosure.

PCIe storage enclosure features

Learn about the main features of the 5888 and EDR1 PCI Express (PCIe) storage enclosures.

Table 1. PCIe storage enclosure features

Feature code	5888	EDR1
Description	IBM EXP30 Ultra solid-state drive (SSD) I/O drawer	IBM EXP30 Ultra solid-state drive (SSD) I/O drawer
System connection	GX++ PCIe2 x8	GX++ PCIe2 x8
Systems supported	8202-E4C, 8205-E6C, 8231-E1C, or 8231-E2C	8202-E4D, 8205-E6D, 8231-E1D, 8231-E2D, 8246-L2T, 8248-L4T, 8268-E1D, 8408-E8D, 8412-EAD, 9109-RMD, 9117-MMC, 9117-MMD, 9179-MHC, and 9179-MHD
Operating systems supported ¹	AIX®, Linux	AIX, IBM i, Linux
High availability (HA) two-system redundant array of independent disks (RAID)	Yes	Yes
HA single-system RAID	Yes	Yes
Requires HA RAID configuration	Yes	Yes
JBOD drives supported	No (requires drives that are formatted with 528 bytes/block)	No (requires drives that are formatted with 528 bytes/block)
Internal solid-state drive (SSD) type	1.8-inch small form factor (SFF) 6 GB Dual Port serial-attached SCSI (SAS) SSD	1.8-inch small form factor (SFF) 6 GB Dual Port serial-attached SCSI (SAS) SSD
SSD drive feature codes supported	ES02	ES02 (AIX and Linux), ES04 (IBM i)
Internal SSD drives	Six minimum to 30 maximum	Six minimum to 30 maximum

Table 1. PCIe storage enclosure features (continued)

Feature code	5888	EDR1
External hard disk drives (HDD)	None	48 maximum
External SAS enclosures	None	Two 5887 disk drive enclosures maximum
Drive redundant SAS paths	Two paths from each enclosure RAID module (ERM) (one path through each SAS expander)	Two paths from each enclosure RAID module (ERM) (one path through each SAS expander)
Drive concurrent maintenance	Yes	Yes
Enclosure RAID module (ERM)	PCIe2 3.1 GB cache RAID SAS enclosure 6 GB x8	PCIe2 3.1 GB cache RAID SAS enclosure 6 GB x8
ERM custom card identification number (CCIN)	57C3	57C3
ERM RAID levels	RAID 0, 5, 6, and 10 with hot spare for 5, 6, and 10	RAID 0, 5, 6, and 10 with hot spare for 5, 6, and 10
ERM write cache size	3.1 GB	3.1 GB
ERM external SAS links	None	Two mini SAS HD 4x connectors that contain three physical links each
ERM concurrent maintenance	No	Yes
ERM fan assembly	Two redundant fans per ERM	Two redundant fans per ERM
ERM fan concurrent maintenance	No	Yes
Redundant power supplies	Two	Two
Power supply concurrent maintenance	Yes	Yes
¹ See Managing PCI adapters		

Cabling the PCIe storage enclosure

Use this information as a guide for cabling your storage enclosure.

Cabling the 5888 PCIe storage enclosure to an 8202-E4C or 8205-E6C system

Use this information as a guide for cabling your PCIe storage enclosure to an 8202-E4C or 8205-E6C system.

Figure 3 on page 5 shows one 5888 PCIe storage enclosure connected to a single 8202-E4C or 8205-E6C system by using one feature code (FC) EJ03 PCIe2 GX++ adapter and two PCIe cables.

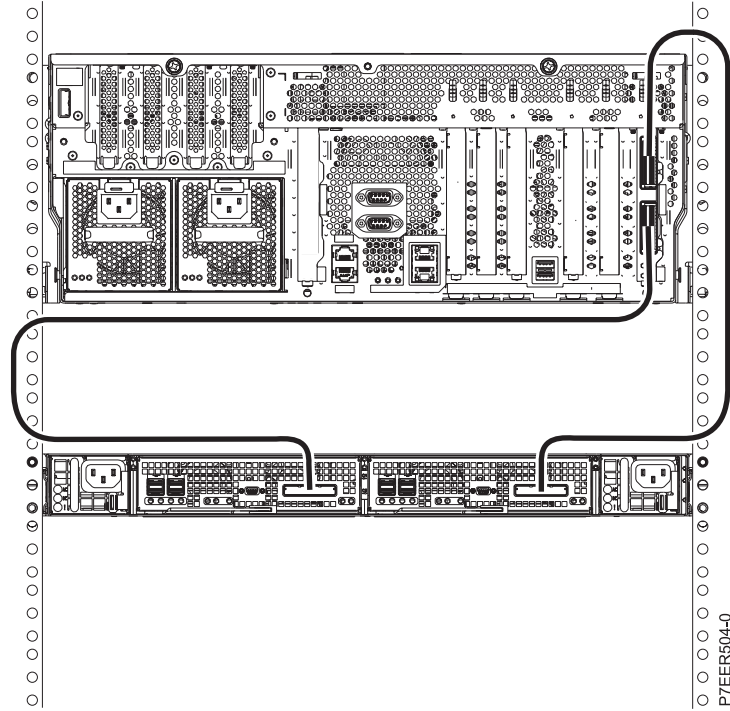

Figure 3. One 5888 PCIe storage enclosure connected to a single 8202-E4C or 8205-E6C system by using one FC EJ03 PCIe2 GX++ adapter and two PCIe cables

Figure 4 on page 6 shows one 5888 PCIe storage enclosure connected to an 8205-E6C system by using two FC EJ03 PCIe2 GX++ adapters and two PCIe cables.

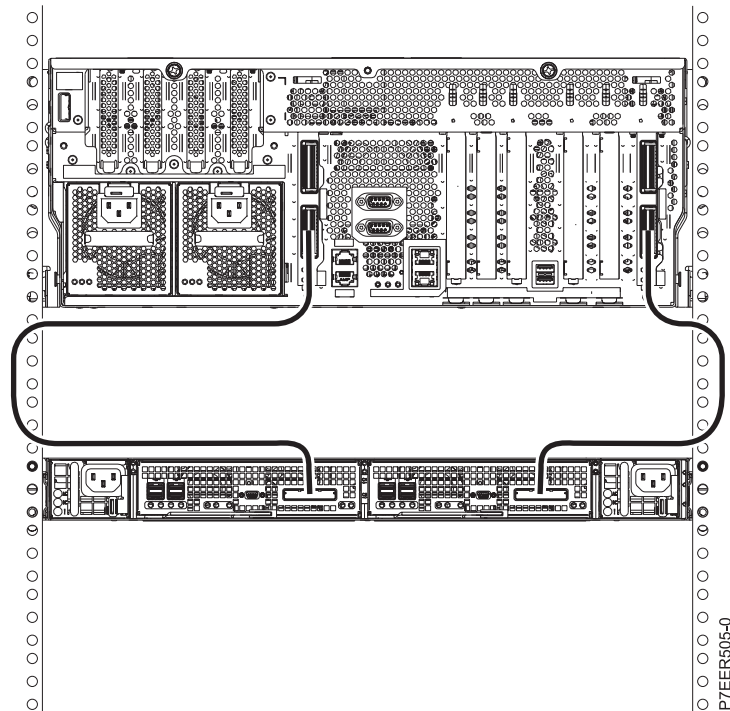

Figure 4. One 5888 PCIe storage enclosure connected to a single 8205-E6C system by using two FC EJ03 PCIe2 GX++ adapters and two PCIe cables

Figure 5 shows two 5888 PCIe storage enclosures connected to a single 8205-E6C system by using two FC EJ03 PCIe2 GX++ adapters and four PCIe cables.

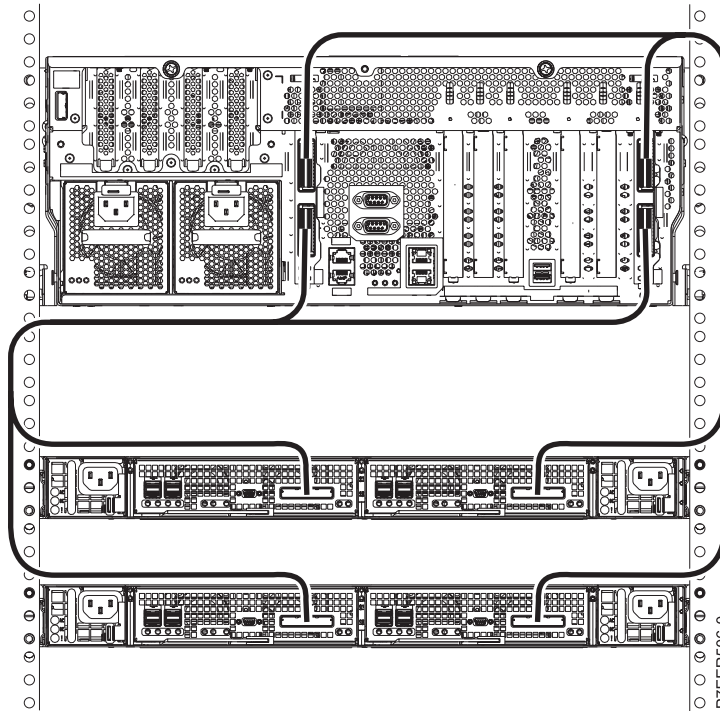

Figure 5. Two 5888 PCIe storage enclosures connected to a single 8205-E6C system by using two FC EJ03 PCIe2 GX++ adapters and four PCIe cables

Figure 6 on page 7 shows one 5888 PCIe storage enclosure connected to two 8202-E4C or 8205-E6C systems by using two FC EJ03 PCIe2 GX++ adapters and two PCIe cables.

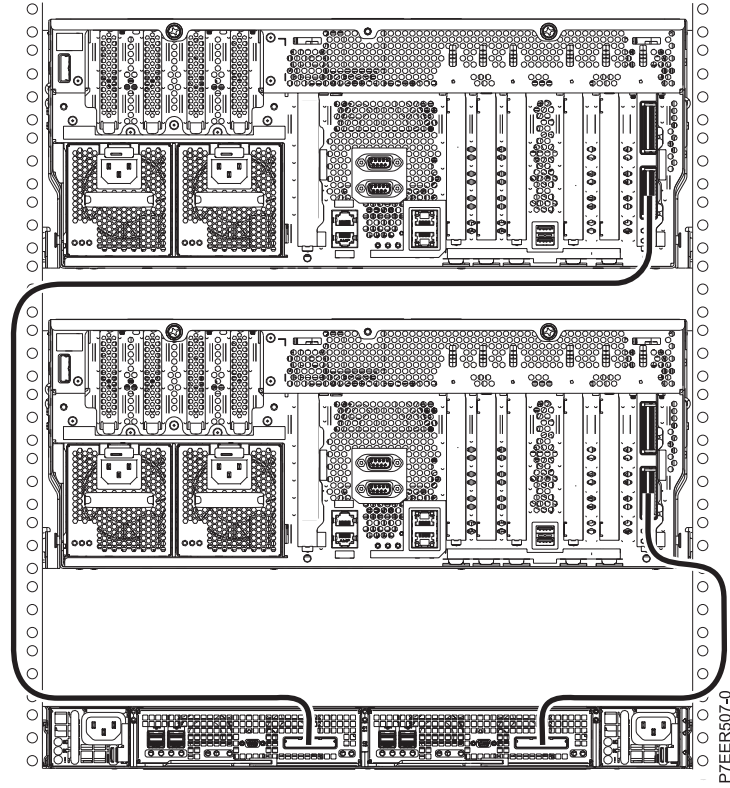

Figure 6. One 5888 PCIe storage enclosure connected to two 8202-E4C or 8205-E6C systems by using two FC EJ03 PCIe2 GX++ adapters and two PCIe cables

Figure 7 on page 8 shows two 5888 PCIe storage enclosures connected to two 8202-E4C or 8205-E6C systems by using two FC EJ03 PCIe2 GX++ adapters and four PCIe cables.

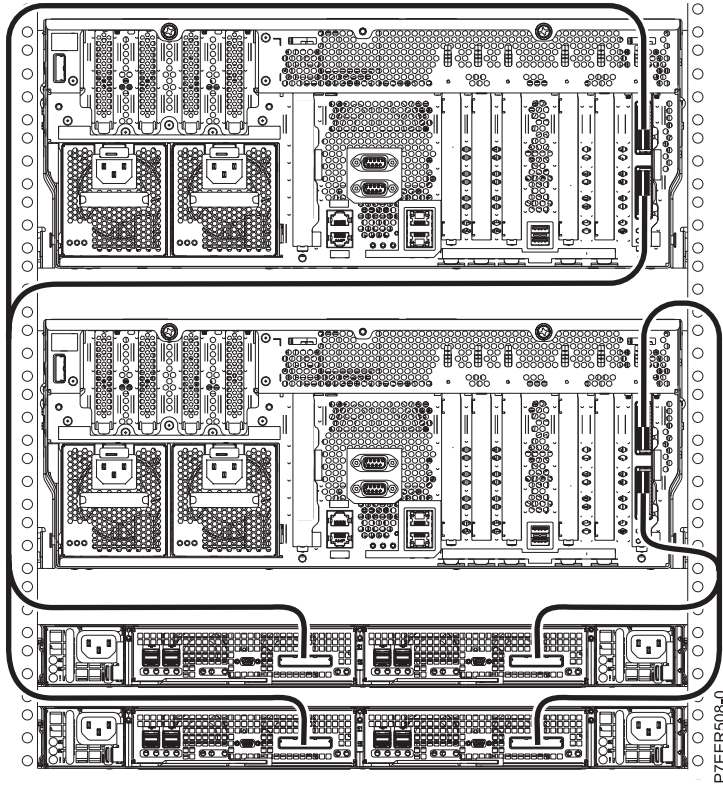

Figure 7. Two 5888 PCIe storage enclosures connected to two 8202-E4C or 8205-E6C systems by using two FC EJ03 PCIe2 GX++ adapters and four PCIe cables

Figure 8 on page 9 shows four 5888 PCIe storage enclosures connected to two 8205-E6C systems by using four FC EJ03 PCIe2 GX++ adapters and eight PCIe cables.

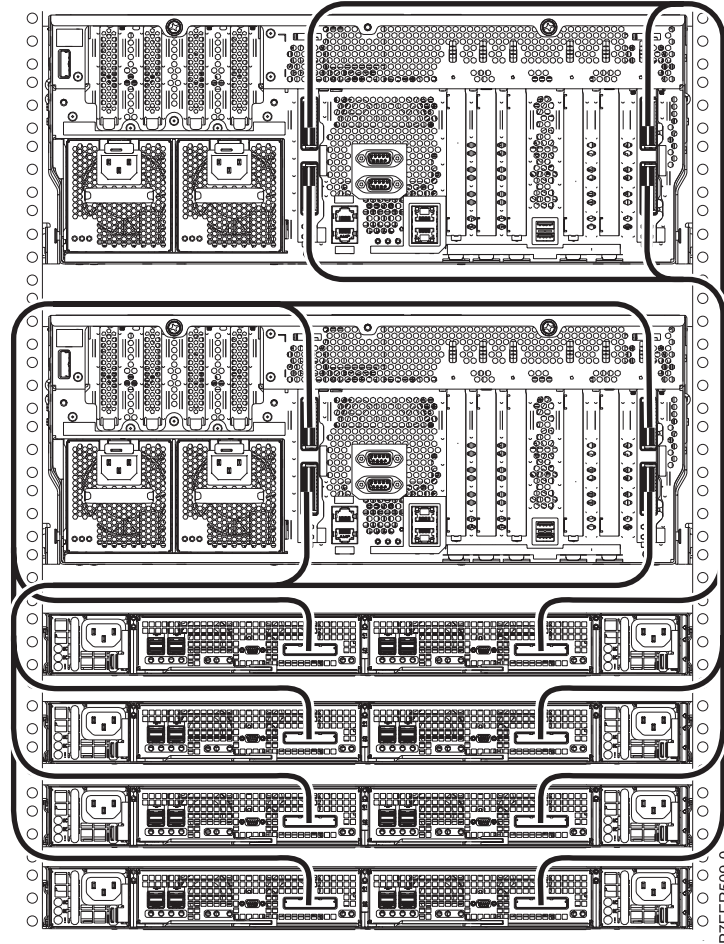

Figure 8. Four 5888 PCIe storage enclosures connected to two 8205-E6C systems by using four FC EJ03 PCIe2 GX++ adapters and eight PCIe cables

Cabling the EDR1 PCIe storage enclosure to an 8202-E4D or 8205-E6D system

Use this information as a guide for cabling your PCIe storage enclosure to an 8202-E4D or 8205-E6D system.

Figure 9 on page 10 shows one EDR1 PCIe storage enclosure connected to a single 8202-E4D or 8205-E6D system by using one feature code (FC) EJ03 PCIe2 GX++ adapter and two PCIe cables.

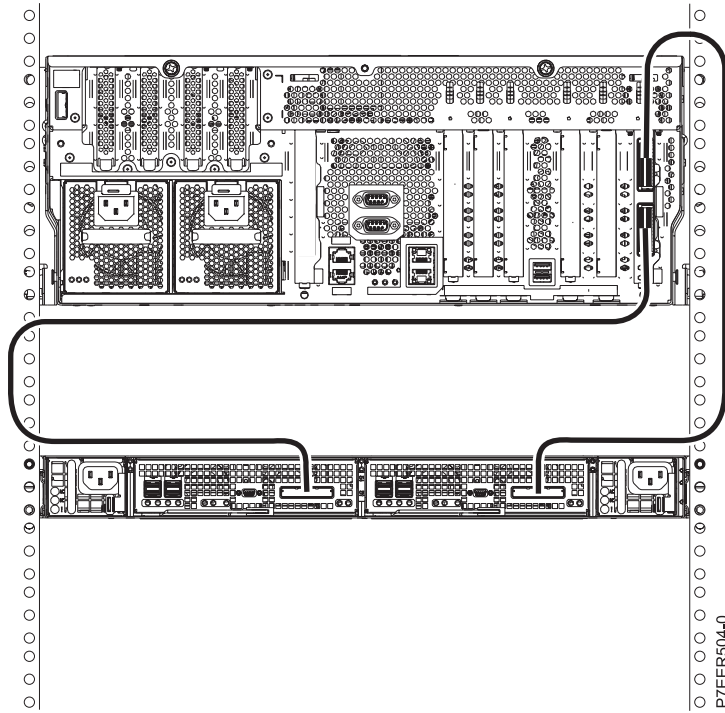

Figure 9. One EDR1 PCIe storage enclosure connected to a single 8202-E4D or 8205-E6D system by using one FC EJ03 PCIe2 GX++ adapter and two PCIe cables

Figure 10 on page 11 shows one EDR1 PCIe storage enclosure connected to an 8205-E6D system by using two FC EJ03 PCIe2 GX++ adapters and two PCIe cables.

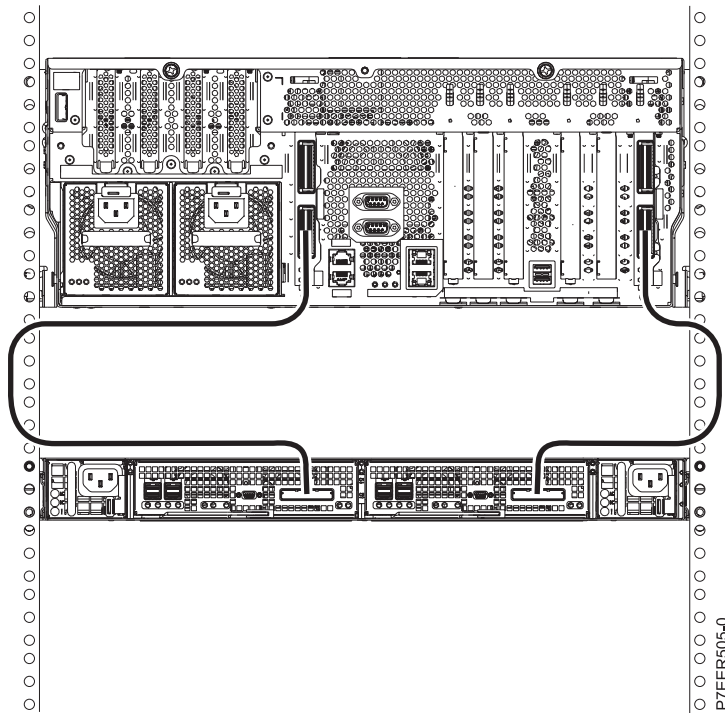

Figure 10. One EDR1 PCIe storage enclosure connected to a single 8205-E6D system by using two FC EJ03 PCIe2 GX++ adapters and two PCIe cables

Figure 11 shows two EDR1 PCIe storage enclosures connected to a single 8205-E6D system by using two FC EJ03 PCIe2 GX++ adapters and four PCIe cables.

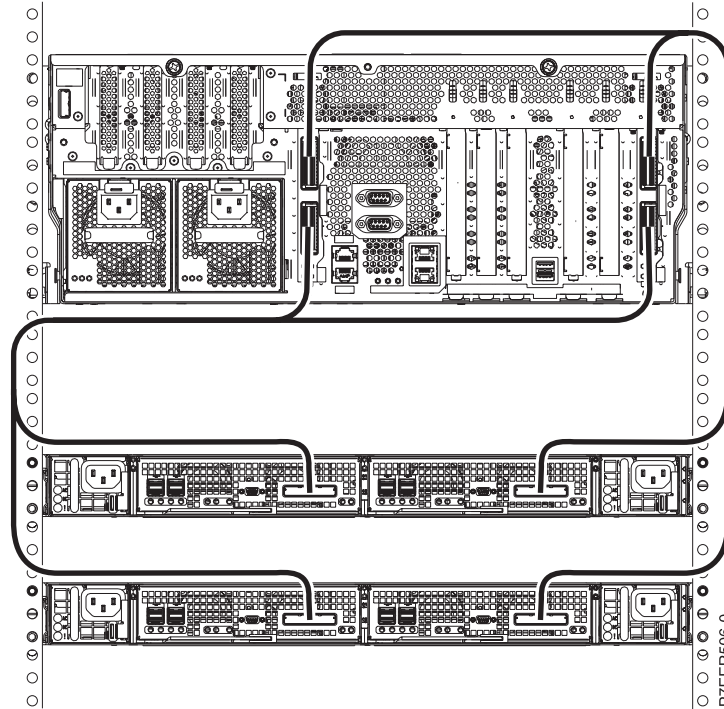

Figure 11. Two EDR1 PCIe storage enclosures connected to a single 8205-E6D system by using two FC EJ03 PCIe2 GX++ adapters and four PCIe cables

Figure 12 on page 12 shows one EDR1 PCIe storage enclosure connected to two 8202-E4D or 8205-E6D systems by using two FC EJ03 PCIe2 GX++ adapters and two PCIe cables.

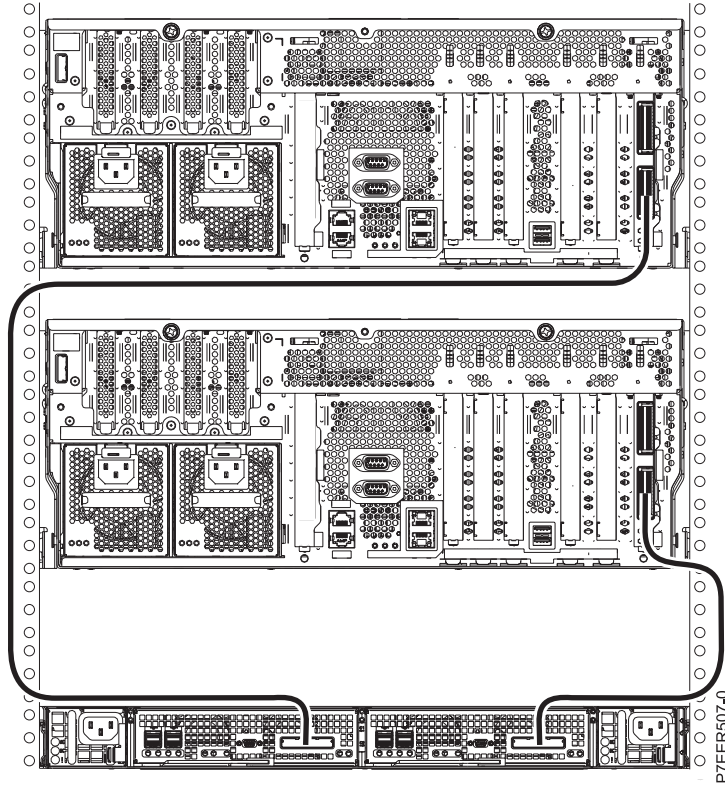

Figure 12. One EDR1 PCIe storage enclosure connected to two 8202-E4D or 8205-E6D systems by using two FC EJ03 PCIe2 GX++ adapters and two PCIe cables

Figure 13 on page 13 shows two EDR1 PCIe storage enclosures connected to two 8202-E4D or 8205-E6D systems by using two FC EJ03 PCIe2 GX++ adapters and four PCIe cables.

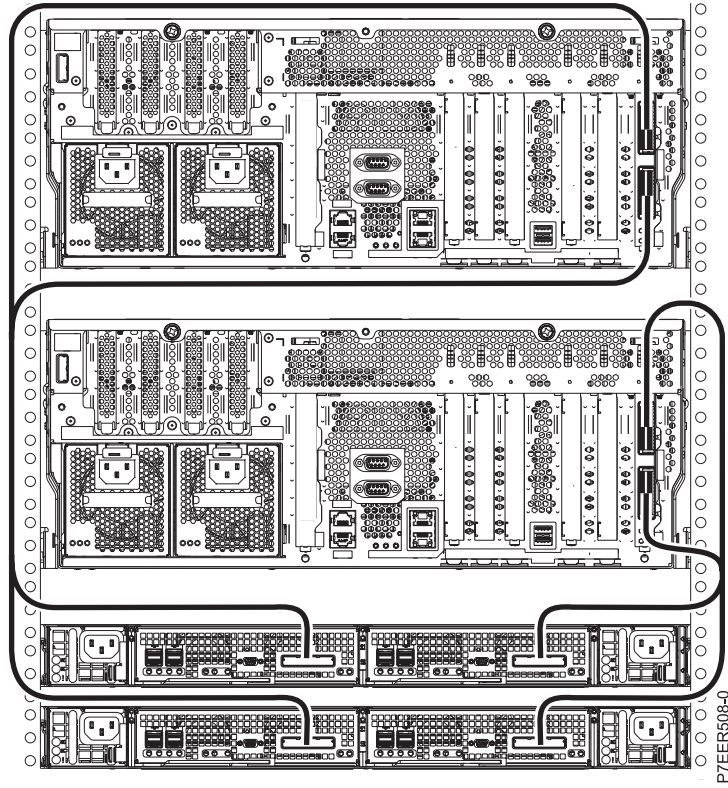

Figure 13. Two EDR1 PCIe storage enclosures connected to two 8202-E4D or 8205-E6D systems by using two FC EJ03 PCIe2 GX++ adapters and four PCIe cables

Figure 14 on page 14 shows four EDR1 PCIe storage enclosures connected to two 8205-E6D systems by using four FC EJ03 PCIe2 GX++ adapters and eight PCIe cables.

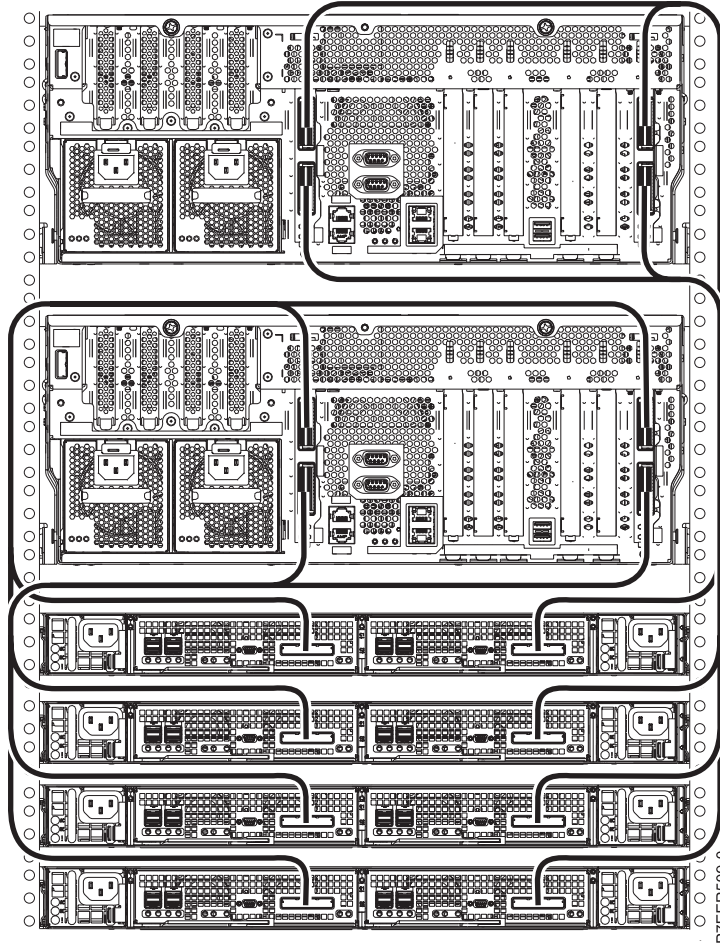

Figure 14. Four EDR1 PCIe storage enclosures connected to two 8205-E6D systems by using four FC EJ03 PCIe2 GX++ adapters and eight PCIe cables

Cabling the 5887 disk drive enclosure to an EDR1 PCIe storage enclosure that is attached to an 8202-E4D or 8205-E6D

Use this information as a guide for cabling your disk drive enclosure to your PCIe storage enclosure.

Figure 15 on page 15 shows one 8202-E4D or 8205-E6D with two 5887 disk drive enclosures connected to one EDR1 PCIe storage enclosure by using four SAS EX cables.

Note: The IBM i operating system does not support attaching more than one 5887 disk drive enclosure to an EDR1 PCIe storage enclosure.

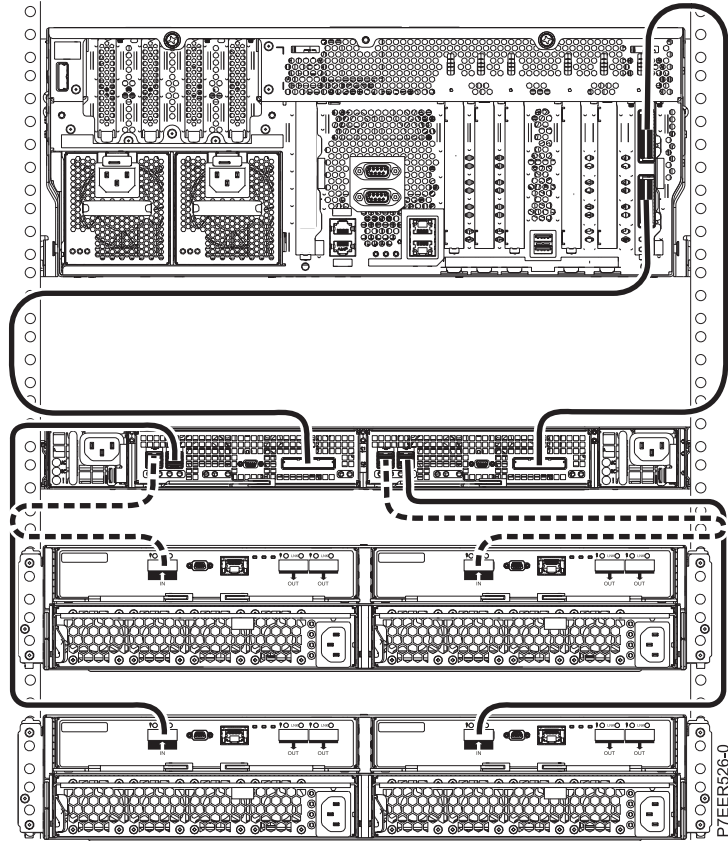

Figure 15. One 8202-E4D or 8205-E6D with two 5887 disk drive enclosures connected to a single EDR1 PCIe storage enclosure by using four SAS EX cables

Cabling the 5888 PCIe storage enclosure to an 8231-E1C or 8231-E2C system

Use this as a guide for cabling your PCIe storage enclosure to an 8231-E1C or 8231-E2C system.

Figure 16 on page 16 shows an example of connecting a 5888 PCIe storage enclosure to an 8231-E1C or 8231-E2C system by using two feature code (FC) EJ0H PCIe2 GX++ adapters and two PCIe cables.

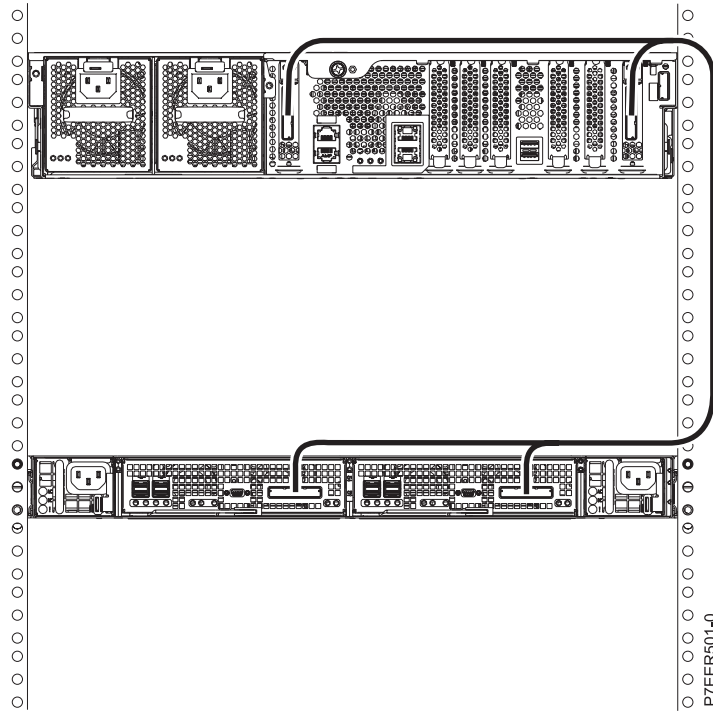

Figure 16. One 5888 PCIe storage enclosure connected to an 8231-E1C or 8231-E2C system by using two FC EJ0H PCIe2 GX++ adapters and two PCIe cables

Figure 17 on page 17 shows one 5888 PCIe storage enclosure connected to two 8231-E1C or 8231-E2C systems by using two FC EJ0H PCIe2 GX++ adapters and two PCIe cables.

Note: The 8231-E1C must be one of two systems in a high-availability configuration in order to support a PCIe storage enclosure as shown in Figure 17 on page 17.

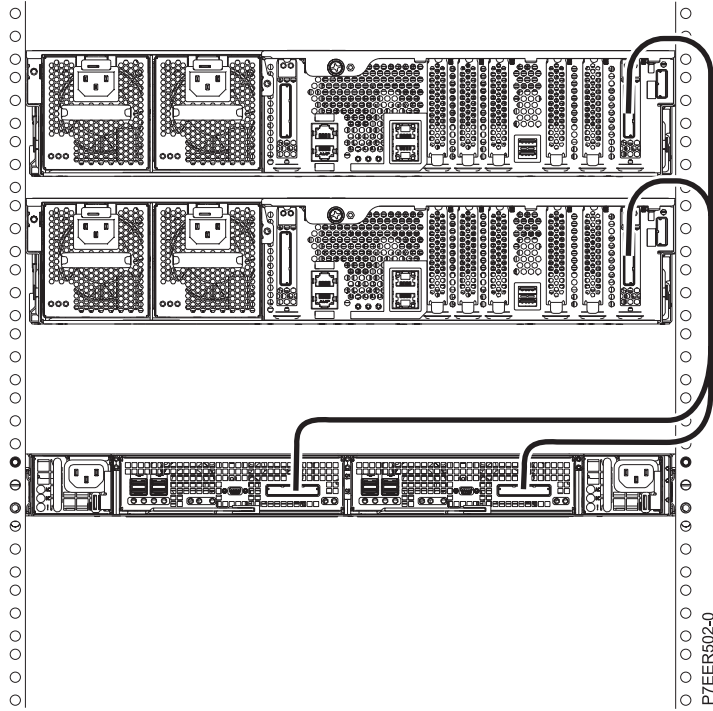

Figure 17. One 5888 PCIe storage enclosure connected to two 8231-E1C or 8231-E2C systems by using two FC E10H PCIe2 GX++ adapters and two PCIe cables

Figure 18 on page 18 shows two 5888 PCIe storage enclosures connected to two 8231-E2C systems by using four FC E10H PCIe2 GX++ adapters and four PCIe cables.

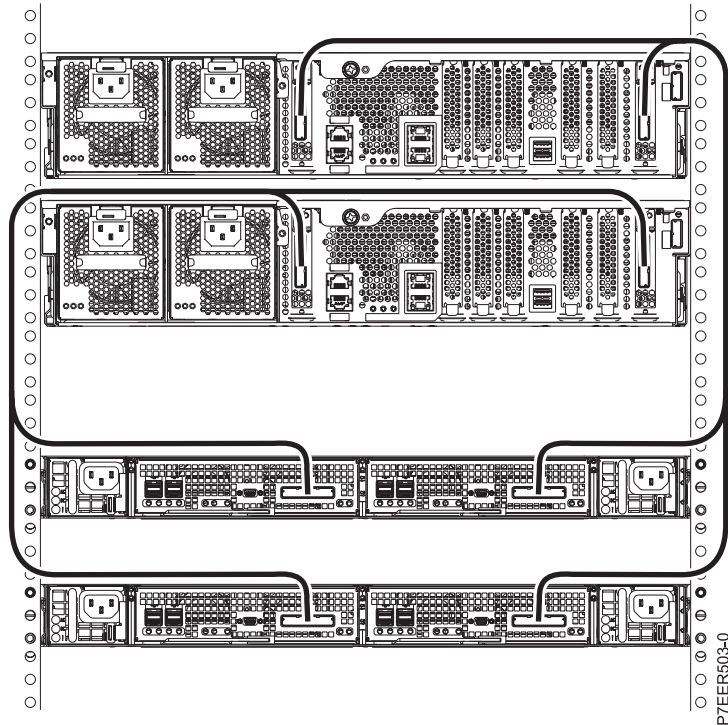

Figure 18. Two 5888 PCIe storage enclosures connected to two 8231-E2C systems by using four FC EJ0H PCIe2 GX++ adapters and four PCIe cables

Cabling the EDR1 PCIe storage enclosure to an 8231-E1D, 8231-E2D, or 8268-E1D system

Use this as a guide for cabling your PCIe storage enclosure to an 8231-E1D, 8231-E2D, or 8268-E1D system.

Figure 19 shows an example of connecting an EDR1 PCIe storage enclosure to an 8231-E2D system by using two feature code (FC) EJ0H PCIe2 GX++ adapters and two PCIe cables.

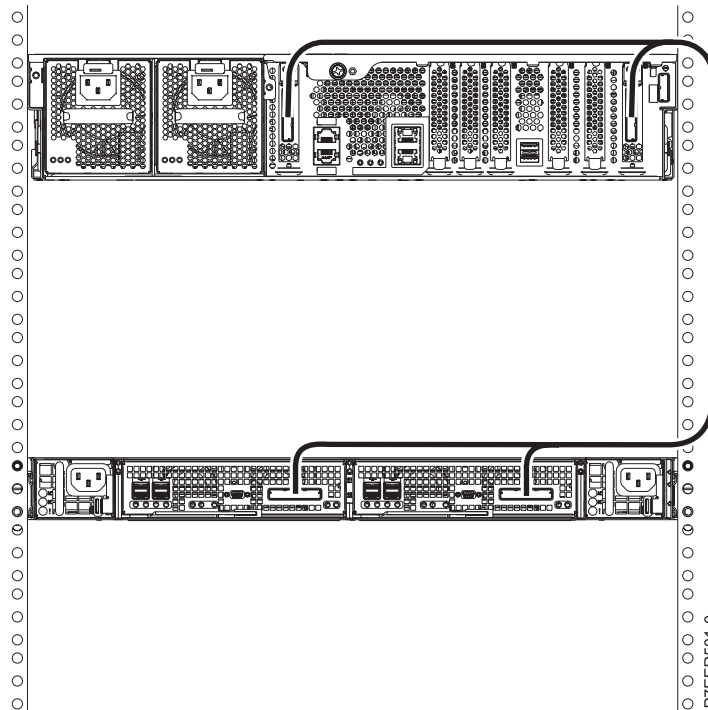

Figure 19. One EDR1 PCIe storage enclosure connected to an 8231-E2D system by using two FC EJ0H PCIe2 GX++ adapters and two PCIe cables

Figure 20 on page 19 shows one EDR1 PCIe storage enclosure connected to two 8231-E1D, 8231-E2D, or 8268-E1D systems by using two FC EJ0H PCIe2 GX++ adapters and two PCIe cables.

Note: The 8231-E1D and 8268-E1D must be one of two systems in a high-availability configuration in order to support a PCIe storage enclosure as is shown in Figure 20 on page 19.

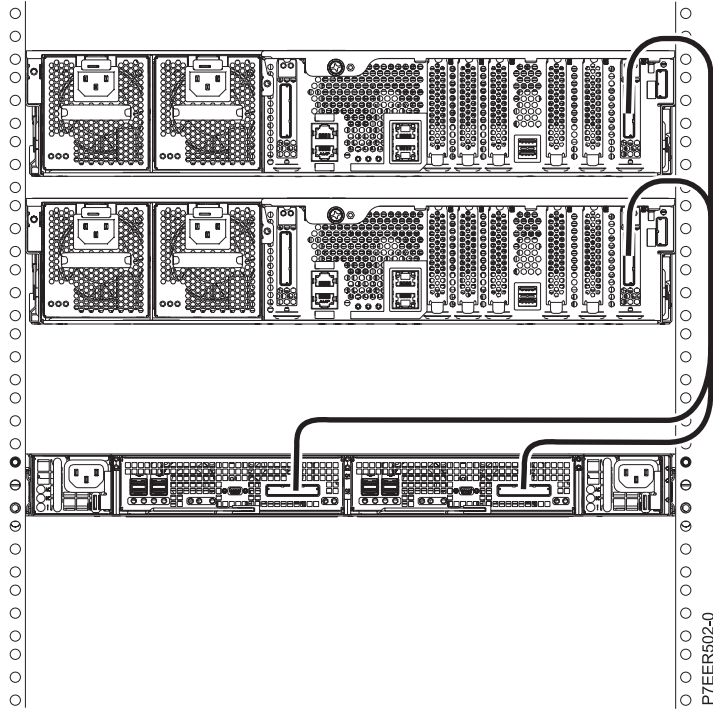

Figure 20. One EDR1 PCIe storage enclosure connected to two 8231-E1D, 8231-E2D, or 8268-E1D systems by using two FC E10H PCIe2 GX++ adapters and two PCIe cables

Figure 21 on page 20 shows two EDR1 PCIe storage enclosures connected to two 8231-E2D systems by using four FC E10H PCIe2 GX++ adapters and four PCIe cables.

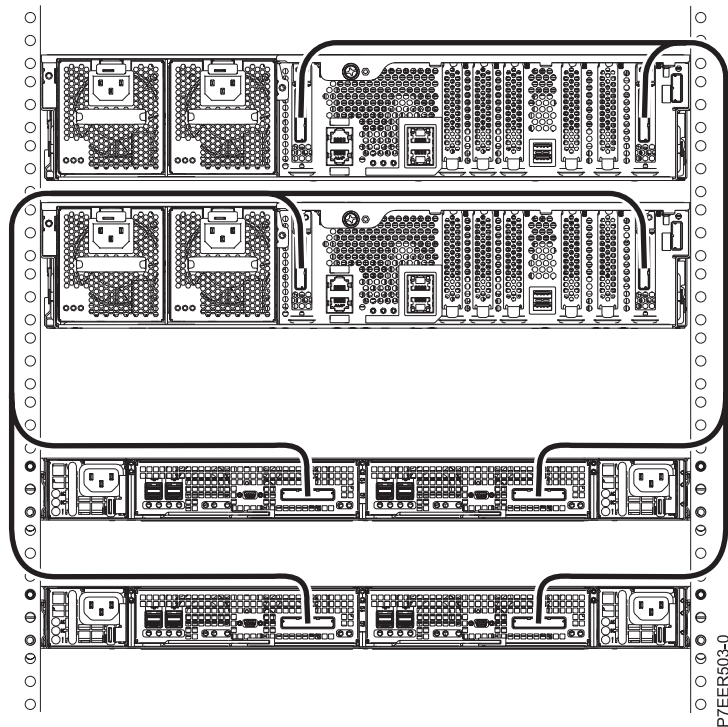

Figure 21. Two EDR1 PCIe storage enclosures connected to two 8231-E2D systems by using four FC EJ0H PCIe2 GX++ adapters and four PCIe cables

Cabling the 5887 disk drive enclosure to an EDR1 PCIe storage enclosure that is attached to an 8231-E1D, 8231-E2D, or 8268-E1D

Use this information as a guide for cabling your disk drive enclosure to your PCIe storage enclosure.

Note: The 8231-E1D and 8268-E1D must be one of two systems in a high-availability configuration in order to support a PCIe storage enclosure.

Figure 22 shows one 8231-E2D with two 5887 disk drive enclosures connected to one EDR1 PCIe storage enclosure by using four SAS EX cables.

Note: The IBM i operating system does not support attaching more than one 5887 disk drive enclosure to an EDR1 PCIe storage enclosure.

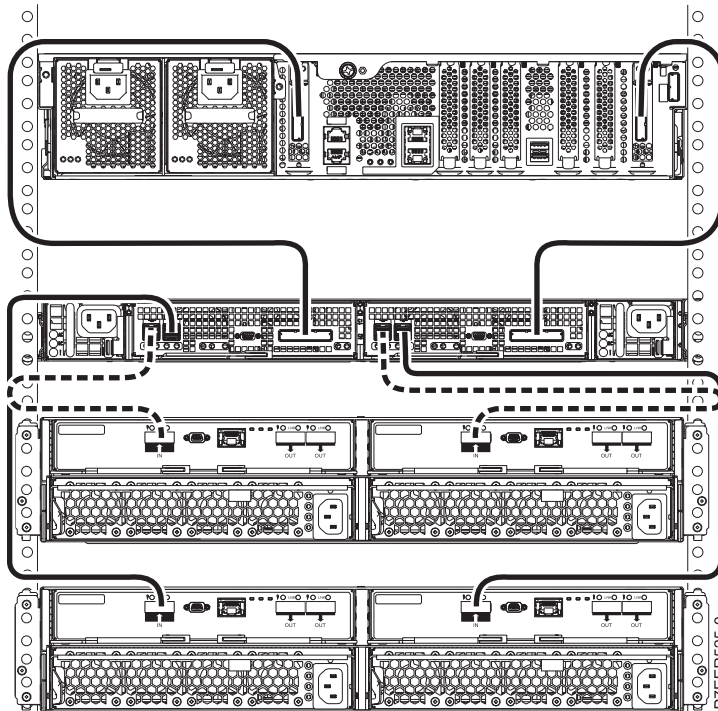

Figure 22. One 8231-E2D with two 5887 disk drive enclosures connected to a single EDR1 PCIe storage enclosure by using four SAS EX cables

Cabling the EDR1 PCIe storage enclosure to an 8246-L2T system

Use this as a guide for cabling your PCIe storage enclosure to an 8246-L2T system.

Figure 23 on page 21 shows an example of connecting an EDR1 PCIe storage enclosure to an 8246-L2T system by using two feature code (FC) EJ0H PCIe2 GX++ adapters and two PCIe cables.

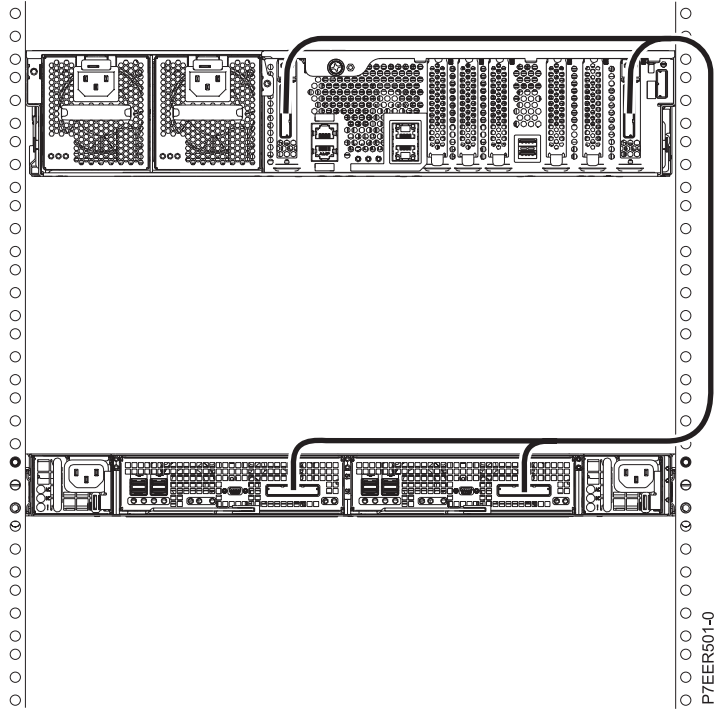

Figure 23. One EDR1 PCIe storage enclosure connected to an 8246-L2T system by using two FC EJ0H PCIe2 GX++ adapters and two PCIe cables

Figure 24 on page 22 shows one EDR1 PCIe storage enclosure connected to two 8246-L2T systems by using two FC EJ0H PCIe2 GX++ adapters and two PCIe cables.

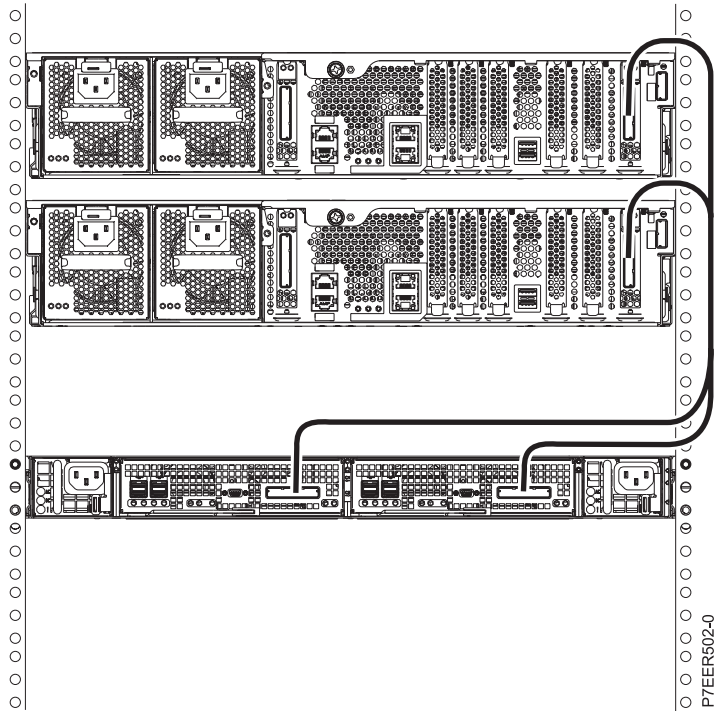

Figure 24. One EDR1 PCIe storage enclosure connected to two 8246-L2T systems by using two FC EJ0H PCIe2 GX++ adapters and two PCIe cables

Figure 25 shows two EDR1 PCIe storage enclosures connected to two 8246-L2T systems by using four FC EJ0H PCIe2 GX++ adapters and four PCIe cables.

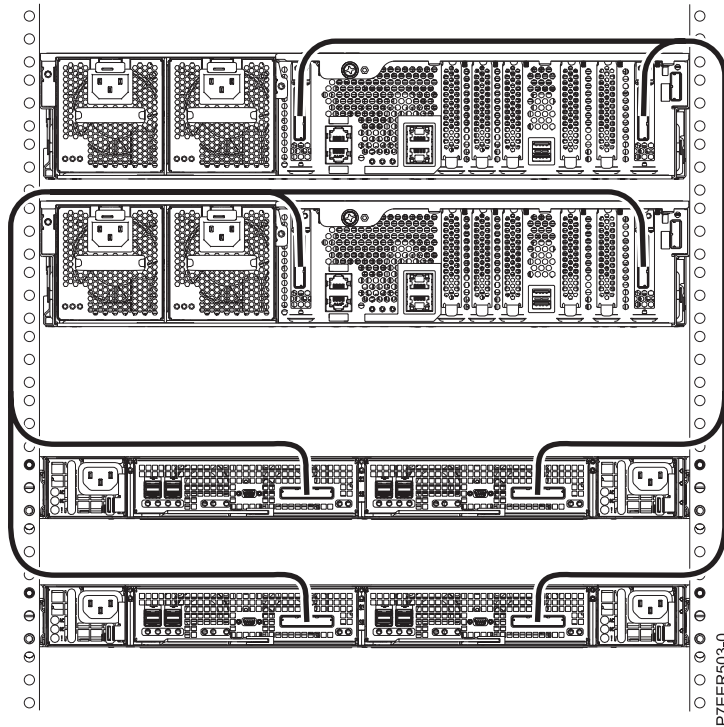

Figure 25. Two EDR1 PCIe storage enclosures connected to two 8246-L2T systems by using four FC EJ0H PCIe2 GX++ adapters and four PCIe cables

Cabling the 5887 disk drive enclosure to an EDR1 PCIe storage enclosure that is attached to an 8246-L2T

Use this information as a guide for cabling your disk drive enclosure to your PCIe storage enclosure.

Figure 26 on page 23 shows one 8246-L2T with two 5887 disk drive enclosures connected to one EDR1 PCIe storage enclosure by using four SAS EX cables.

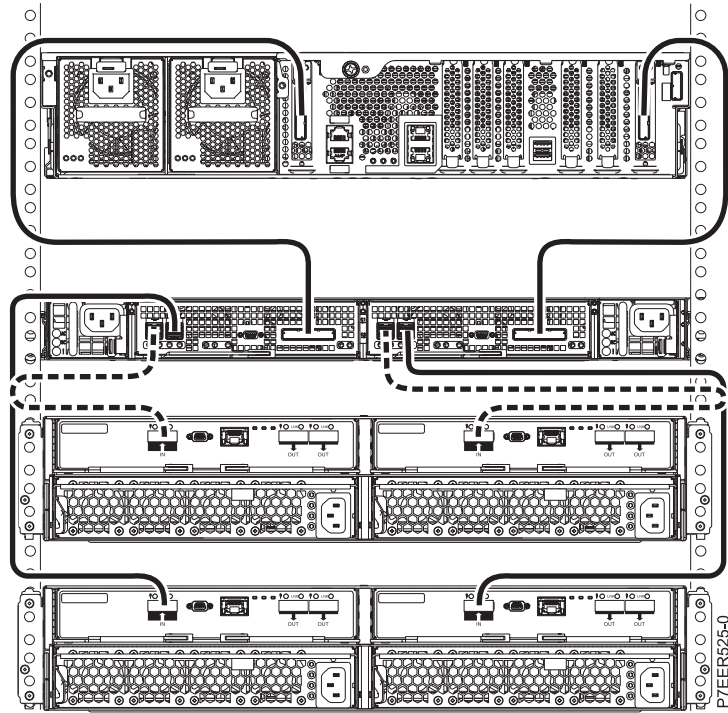

Figure 26. One 8246-L2T with two 5887 disk drive enclosures connected to a single EDR1 PCIe storage enclosure by using four SAS EX cables

Cabling the EDR1 PCIe storage enclosure to an 8248-L4T, 8408-E8D, or 9109-RMD system

Use this information as a guide for cabling your PCIe storage enclosure to an 8248-L4T, 8408-E8D, or 9109-RMD system.

Figure 27 on page 24 shows one EDR1 PCIe storage enclosure connected to a single 8248-L4T, 8408-E8D, or 9109-RMD system by using one feature code (FC) 1914 PCIe2 GX++ adapter and two PCIe cables.

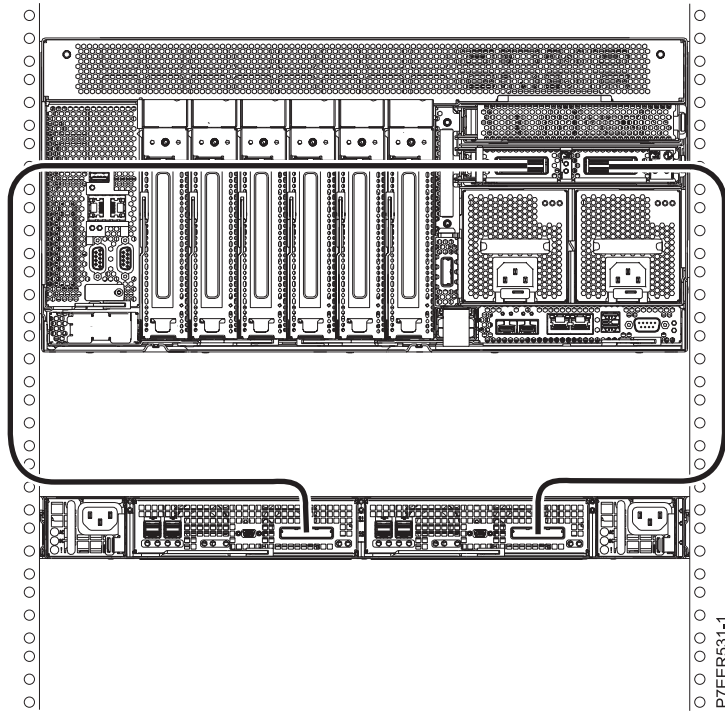

Figure 27. One EDR1 PCIe storage enclosure connected to a single 8248-L4T, 8408-E8D, or 9109-RMD system by using one FC 1914 PCIe2 GX++ adapter and two PCIe cables

Figure 28 on page 25 shows one EDR1 PCIe storage enclosure connected to a single 8248-L4T, 8408-E8D, or 9109-RMD system by using two FC 1914 PCIe2 GX++ adapters and two PCIe cables.

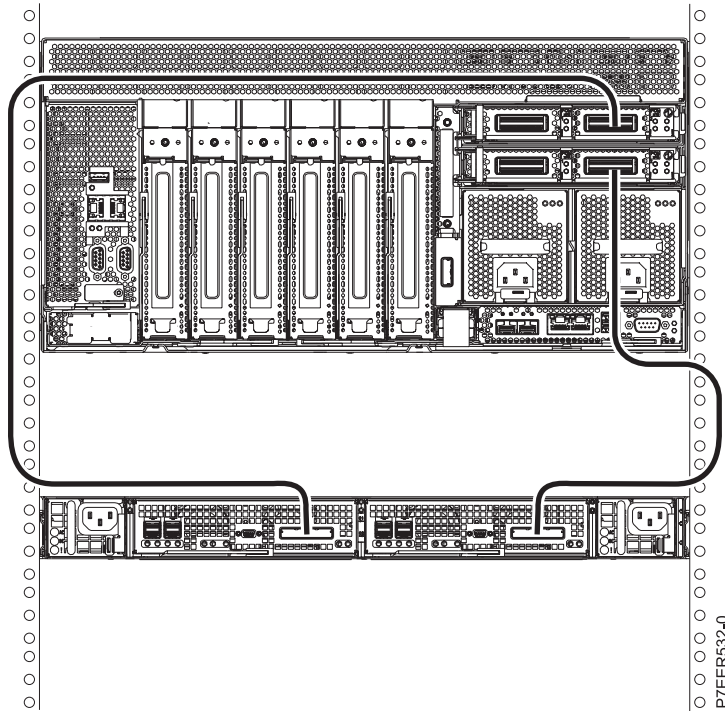

Figure 28. One EDR1 PCIe storage enclosure connected to a single 8248-L4T, 8408-E8D, or 9109-RMD system by using two FC 1914 PCIe2 GX++ adapters and two PCIe cables

Figure 29 shows two EDR1 PCIe storage enclosures connected to a single 8248-L4T, 8408-E8D, or 9109-RMD system by using two FC 1914 PCIe2 GX++ adapters and four PCIe cables.

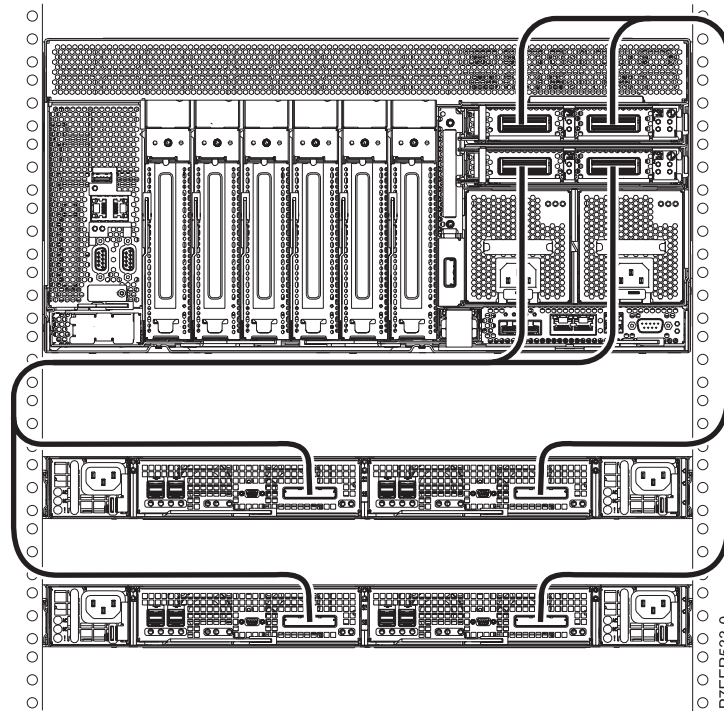

Figure 29. Two EDR1 PCIe storage enclosures connected to a single 8248-L4T, 8408-E8D, or 9109-RMD system by using two FC 1914 PCIe2 GX++ adapters and four PCIe cables

Cabling the 5887 disk drive enclosure to an EDR1 PCIe storage enclosure that is attached to an 8248-L4T, 8408-E8D, or 9109-RMD

Use this information as a guide for cabling your disk drive enclosure to your PCIe storage enclosure.

Figure 30 on page 26 shows one 8248-L4T, 8408-E8D, or 9109-RMD with two 5887 disk drive enclosures connected to one EDR1 PCIe storage enclosure by using four SAS EX cables.

Note: The IBM i operating system does not support attaching more than one 5887 disk drive enclosure to an EDR1 PCIe storage enclosure.

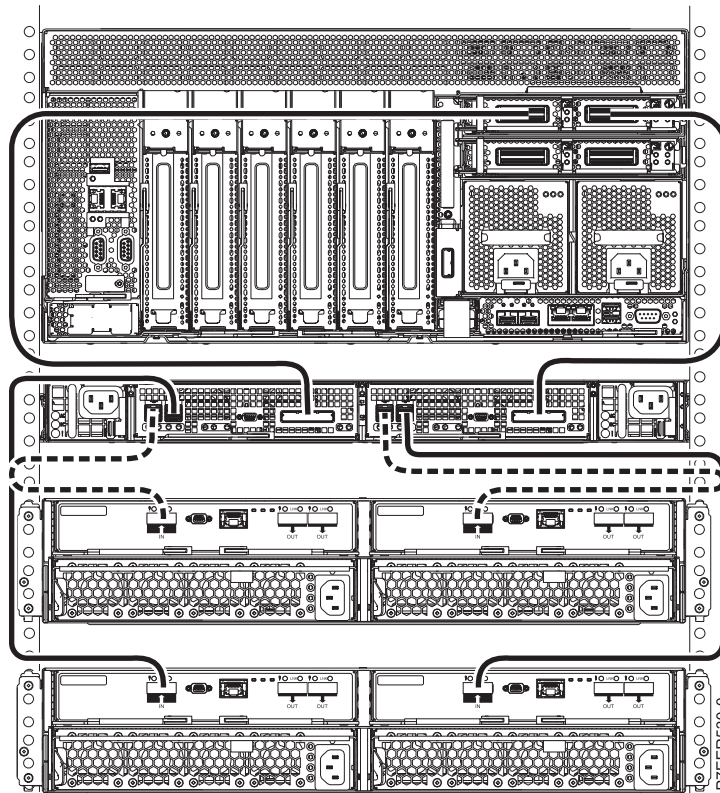

Figure 30. one 8248-L4T, 8408-E8D, or 9109-RMD with two 5887 disk drive enclosures connected to one EDR1 PCIe storage enclosure by using four SAS EX cables

Cabling the EDR1 PCIe storage enclosure to an 8412-EAD, 9117-MMC, 9117-MMD, 9179-MHC, or 9179-MHD system

Use this information as a guide for cabling your PCIe storage enclosure to an 8412-EAD, 9117-MMC, 9117-MMD, 9179-MHC, or 9179-MHD system.

Figure 31 on page 27 shows one EDR1 PCIe storage enclosure connected to a single 8412-EAD, 9117-MMC, 9117-MMD, 9179-MHC, or 9179-MHD system by using one feature code (FC) 1914 PCIe2 GX++ adapter and two PCIe cables.

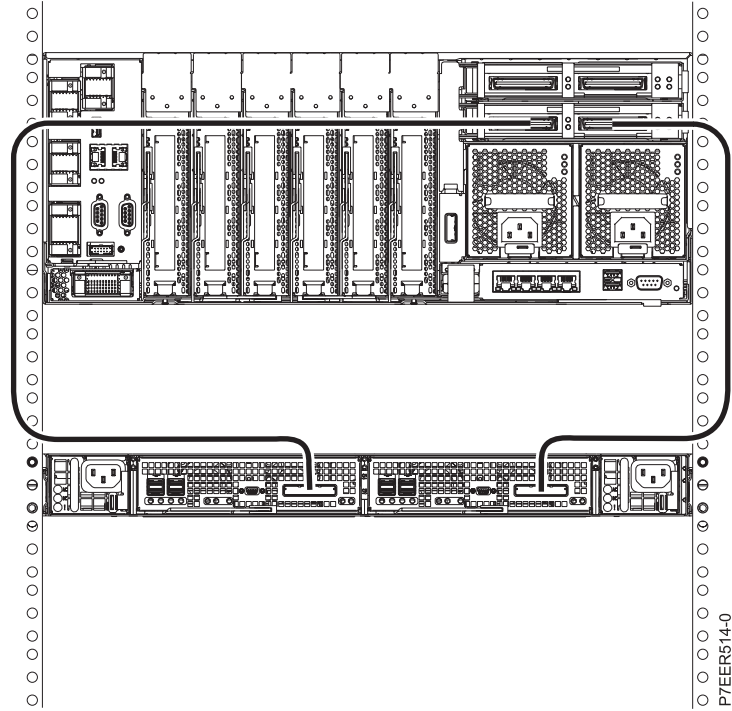

Figure 31. One EDR1 PCIe storage enclosure connected to a single 8412-EAD, 9117-MMC, 9117-MMD, 9179-MHC, or 9179-MHD system by using one FC 1914 PCIe2 GX++ adapter and two PCIe cables

Figure 32 on page 28 shows one EDR1 PCIe storage enclosure connected to an 8412-EAD, 9117-MMC, 9117-MMD, 9179-MHC, or 9179-MHD system by using two FC 1914 PCIe2 GX++ adapters and two PCIe cables.

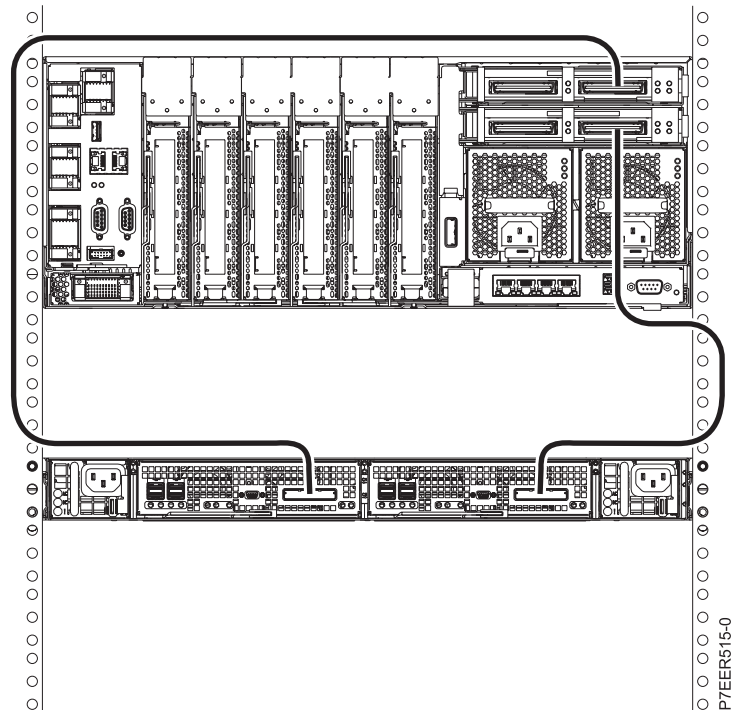

Figure 32. One EDR1 PCIe storage enclosure connected to a single 8412-EAD, 9117-MMC, 9117-MMD, 9179-MHC, or 9179-MHD system by using two FC 1914 PCIe2 GX++ adapters and two PCIe cables

Figure 33 shows two EDR1 PCIe storage enclosures connected to a single 8412-EAD, 9117-MMC, 9117-MMD, 9179-MHC, or 9179-MHD system by using two FC 1914 PCIe2 GX++ adapters and four PCIe cables.

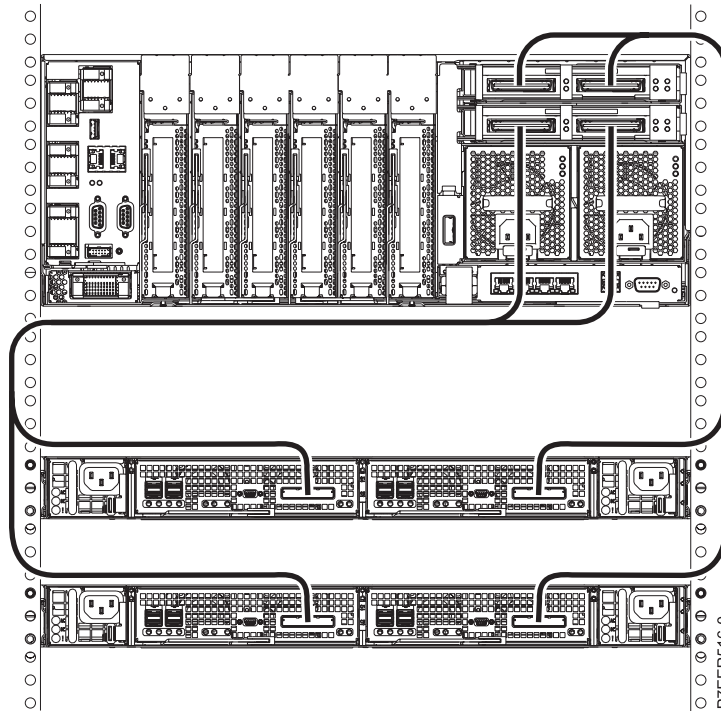

Figure 33. Two EDR1 PCIe storage enclosures connected to a single 8412-EAD, 9117-MMC, 9117-MMD, 9179-MHC, or 9179-MHD system by using two FC 1914 PCIe2 GX++ adapters and four PCIe cables

Figure 34 on page 29 shows one EDR1 PCIe storage enclosure connected to two 8412-EAD, 9117-MMC, 9117-MMD, 9179-MHC, or 9179-MHD systems by using two FC 1914 PCIe2 GX++ adapters and two PCIe cables.

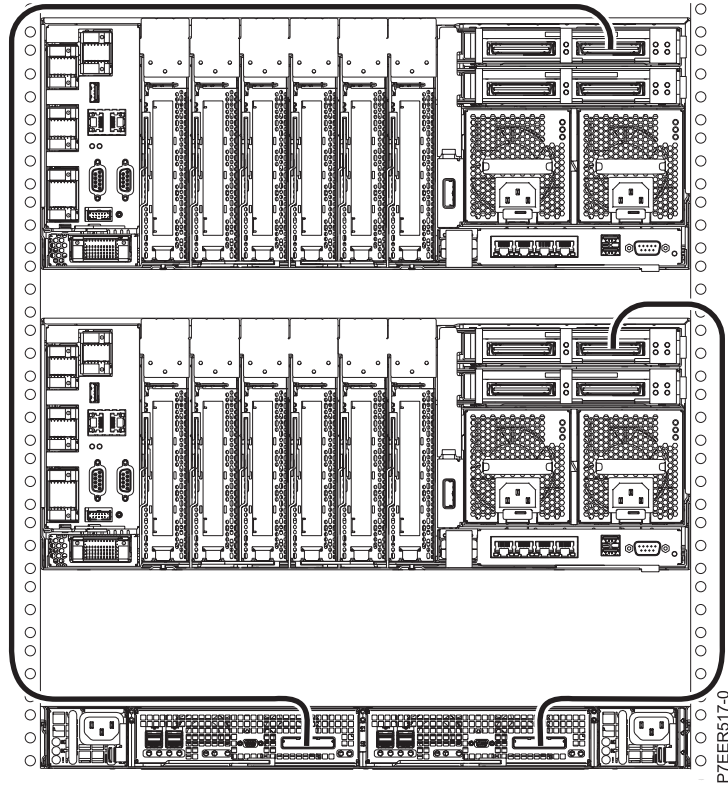

Figure 34. One EDR1 PCIe storage enclosure connected to two 8412-EAD, 9117-MMC, 9117-MMD, 9179-MHC, or 9179-MHD systems by using two FC 1914 PCIe2 GX++ adapters and two PCIe cables

Figure 35 on page 30 shows two EDR1 PCIe storage enclosures connected to two 8412-EAD, 9117-MMC, 9117-MMD, 9179-MHC, or 9179-MHD systems by using two FC 1914 PCIe2 GX++ adapters and four PCIe cables.

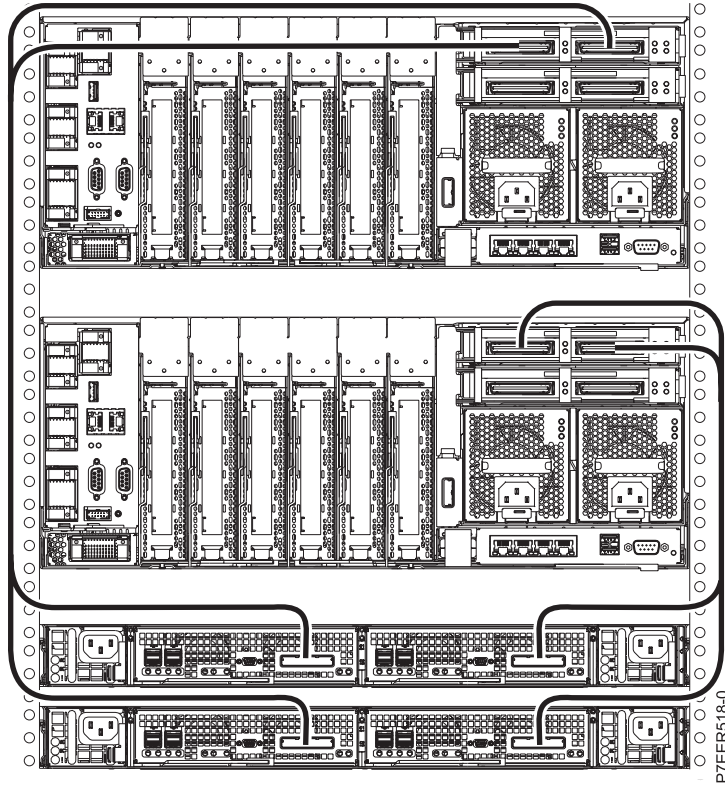

Figure 35. Two EDR1 PCIe storage enclosures connected to two 8412-EAD, 9117-MMC, 9117-MMD, 9179-MHC, or 9179-MHD systems by using two FC 1914 PCIe2 GX++ adapters and four PCIe cables

Figure 36 on page 31 shows four EDR1 PCIe storage enclosures connected to two 8412-EAD, 9117-MMC, 9117-MMD, 9179-MHC, or 9179-MHD systems by using four FC 1914 PCIe2 GX++ adapters and eight PCIe cables.

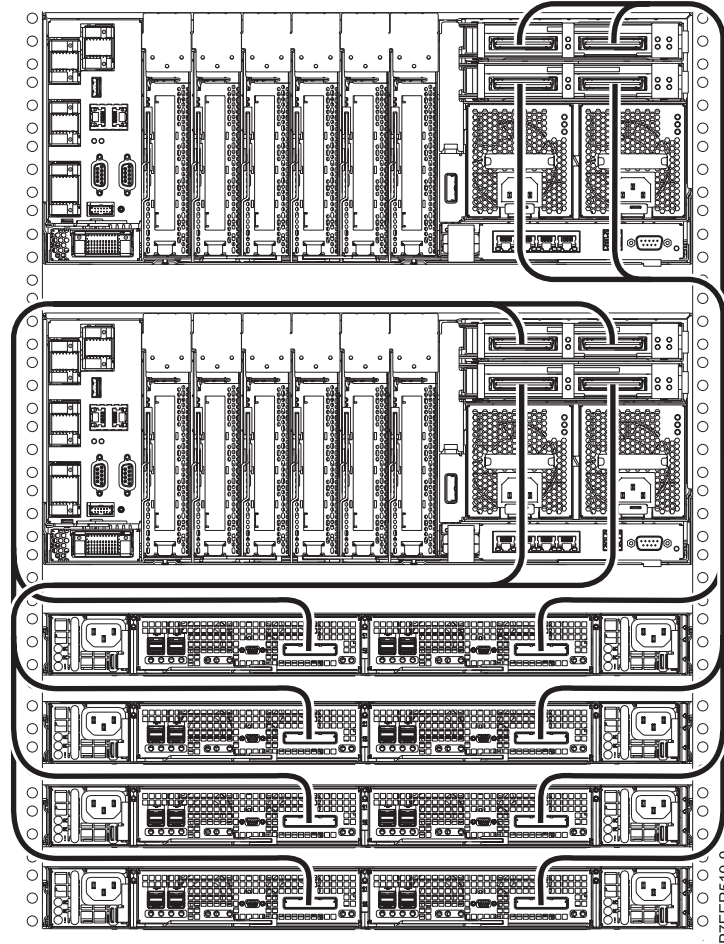

Figure 36. Four EDR1 PCIe storage enclosures connected to two 8412-EAD, 9117-MMC, 9117-MMD, 9179-MHC, or 9179-MHD systems by using four FC 1914 PCIe2 GX++ adapters and eight PCIe cables

Cabling the 5887 disk drive enclosure to an EDR1 PCIe storage enclosure that is attached to an 8412-EAD, 9117-MMC, 9117-MMD, 9179-MHC, or 9179-MHD

Use this information as a guide for cabling your disk drive enclosure to your PCIe storage enclosure.

Note: The IBM i operating system does not support attaching more than one 5887 disk drive enclosure to an EDR1 PCIe storage enclosure.

Figure 37 on page 32 shows one 8412-EAD, 9117-MMC, 9117-MMD, 9179-MHC, or 9179-MHD with one 5887 disk drive enclosure connected to one EDR1 PCIe storage enclosure by using two SAS EX cables.

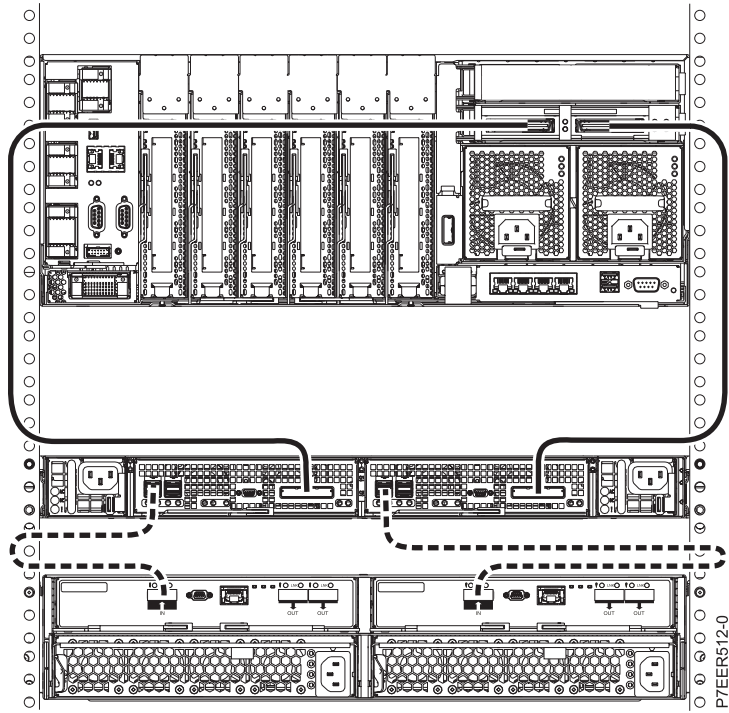

Figure 37. One 8412-EAD, 9117-MMC, 9117-MMD, 9179-MHC, or 9179-MHD with one 5887 disk drive enclosure connected to a single EDR1 PCIe storage enclosure by using two SAS EX cables

Figure 38 on page 33 shows one 8412-EAD, 9117-MMC, 9117-MMD, 9179-MHC, or 9179-MHD with four 5887 disk drive enclosures connected to two EDR1 PCIe storage enclosures by using eight SAS EX cables.

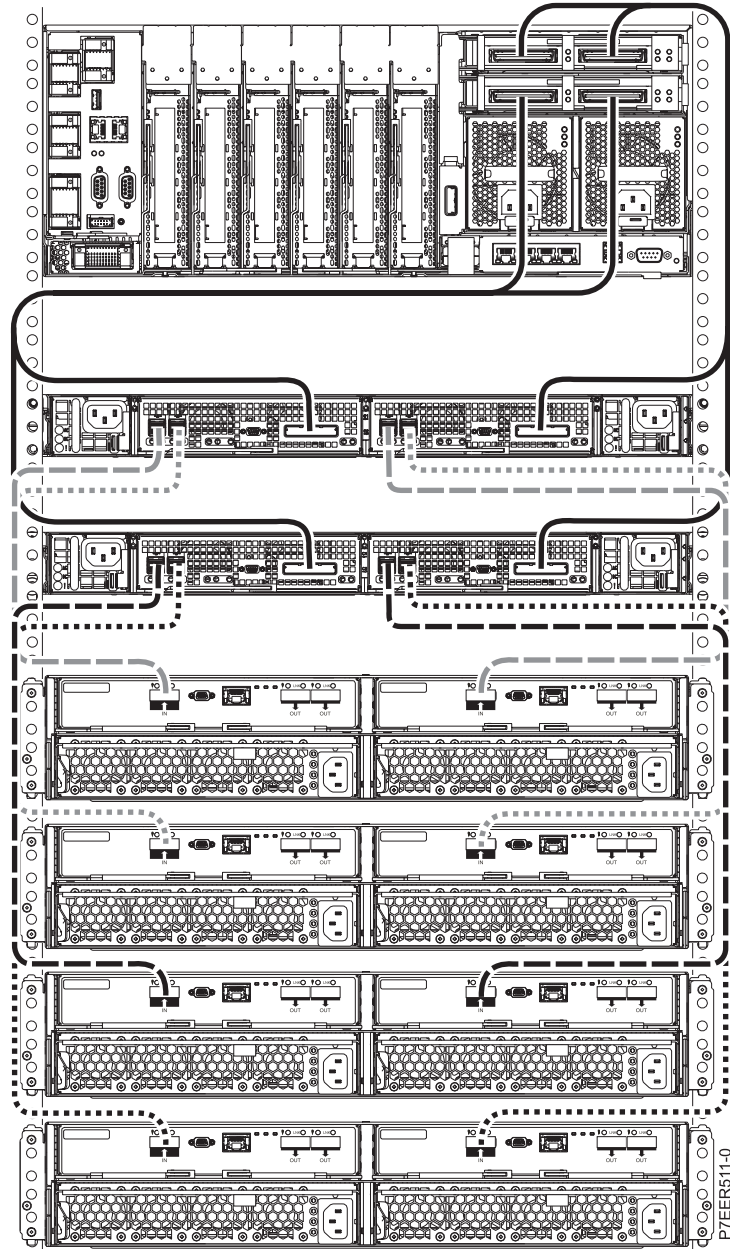

Figure 38. One 8412-EAD, 9117-MMC, 9117-MMD, 9179-MHC, or 9179-MHD with four 5887 disk drive enclosures connected to two EDR1 PCIe storage enclosures by using eight SAS EX cables

Overview of problem determination

The error log analysis is performed on errors presented by the components in the 5888 or EDR1 PCIe storage enclosure, and the analysis recommends actions that need to be performed to correct the errors. Sometimes it refers you to an isolation procedure to further determine what actions can be taken to resolve the problem.

The isolation procedures might refer you to service documentation for an external expansion drawer. The information in this section can be used in those situations.

LED use for the 5888 or EDR1 PCIe storage enclosure

The components inside the 5888 or EDR1 PCIe storage enclosure can be identified by their physical location code. In addition to the location code, most components have an identify light-emitting diode (LED) that can be activated.

For an overview of using location codes, see 5888 or EDR1 PCIe storage enclosure.

For details about the 5888 or EDR1 locations, see 5888 or EDR1 storage enclosure locations.

For the location and description of the 5888 or EDR1 PCIe storage enclosure LEDs, see “5888 or EDR1 PCIe storage enclosure light-emitting diode (LED) locations..”

The identify indicator LEDs can be accessed from the following locations:

- Hardware Management Console (HMC): Click **Operations** > **LED Status** > **Identify LED**
- AIX diagnostics: Type `diag > Task Selection > Identify and Attention Indicators`
- Linux: Type `/usr/sbin/ussysident -s identify -l<location code>`
- Advanced System Management Interface: Click **System Configuration** > **Service Indicators or Indicators by Location Code**

5888 or EDR1 PCIe storage enclosure light-emitting diode (LED) locations.

Use this information to identify the LEDs on the 5888 or EDR1 PCIe storage enclosure.

Figure 39 shows the location of LEDs on the front of the 5888 or EDR1 PCIe storage enclosure.

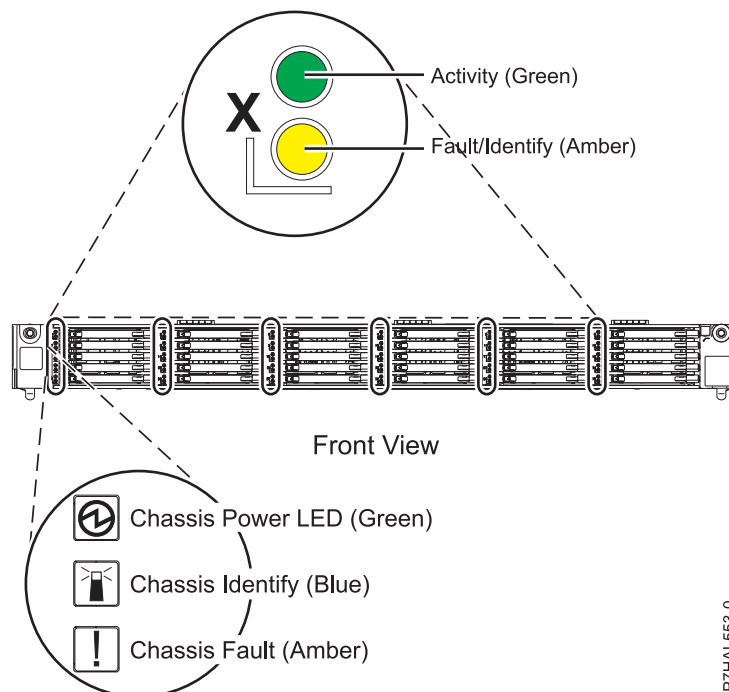

Figure 39. LED locations

Figure 40 on page 35 shows the location of LEDs on the rear of the 5888 or EDR1 PCIe storage enclosure.

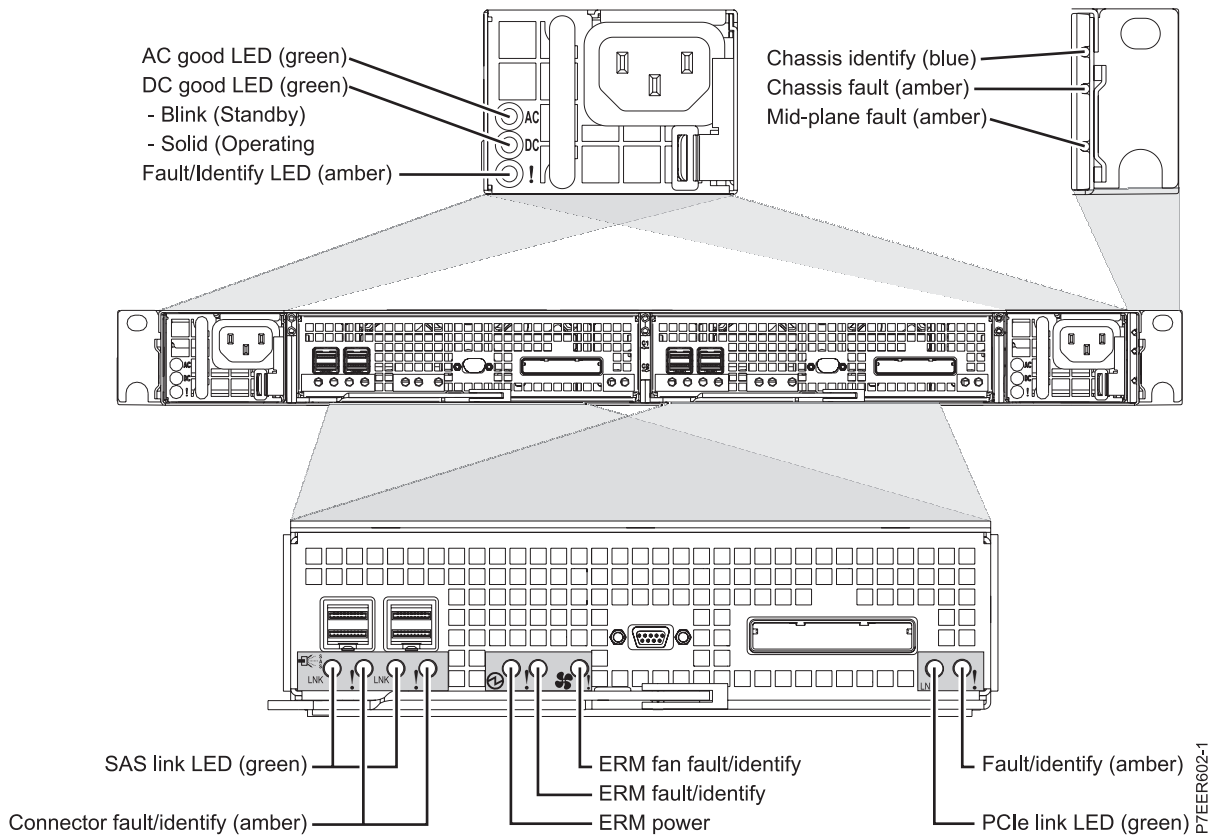

Figure 40. LED locations

RAID controller location code

The RAID controllers are embedded on the enclosure RAID module (ERM) card and connect to the system by using a PCIe cable. All I/O controllers or adapters attached by a PCIe bus on Power Systems servers inherit the location code of the I/O slot to which they connect.

Generally, the location code of an I/O slot is based on the enclosure in which the nearest upstream PCI bridge resides. This is normally a PCI slot, but for a RAID controller in an ERM, it is where the PCIe cable is connected on the GX adapter in the system unit. Therefore, the logical PCIe slot location code for the RAID controller is associated with the PCIe cable connector location on the GX adapter in the system. This logical location code (L1 in the following example) indicates that the associated RAID controller resource connects to the connector.

The logical PCIe slot location of the RAID controller in an ERM is shown in the following form:

Utttt.mmm.ssssss-Pw-Cx-Ty-L1 (-T1), where:

- *Utttt.mmm.ssssss* is the type, model, and serial number of the system central electronics complex (CEC) enclosure in which the GX adapter resides
- *Pw* is the planar in the system CEC enclosure that the GX adapter plugs into
- *Cx* is the slot on the planar that the GX adapter plugs into
- *Ty* is the PCIe connector on the GX adapter
- L1 is the logical RAID controller indicator
- T1 might be appended after L1 in some cases, but can be ignored

The slot location code previously described is used to call out failures that are isolated to the RAID controller or PCIe hardware in the PCIe storage enclosure. The physical location code of the ERM card is used to call out failures that are isolated to other components on the ERM card. The components can include the serial-attached SCSI (SAS) expander or the SCSI enclosure services (SES) device.

Determining the ERM location from the RAID controller location

You will need to use the RAID controller logical location code to determine the enclosure RAID module (ERM) physical location.

Determining the ERM location from the RAID controller location when using AIX:

Learn how to use the AIX operating system to determine the physical location of the RAID controller on the enclosure RAID module (ERM) when you have the RAID controller logical location code.

Use one of the following methods to determine the RAID controller physical location:

- “Using the adapter VPD information”
- “Finding the port of the GX adapter”
- “Using the operating system tools”

Using the adapter VPD information

You can display the adapter vital product data (VPD) to determine whether the **FRU Label** field contains a location. In some instances, this field might be blank and one of the other methods must be used to determine the ERM physical location.

An example of finding the physical location for RAID controller `sissas2` resource follows.

1. Use the AIX `lscfg` command to display the VPD of the RAID controller:

```
lscfg -vl sissas2
```

Information similar to the following is displayed:

```

sissas2 Available 03-00 PCIe2 3 1GB Cache RAID SAS Enclosure 6Gb x8
(0) root # Y0562p1 : /
# lscfg -vl sissas2
sissas2 U204E 001 DBJ0634-P1-C3-T1-L1-T1 PCIe2 3 1GB Cache RAID SAS E
nclosure 6Gb x8
    PCIe2 3 1GB Cache RAID SAS Enclosure 6Gb x8 :
    Part Number:..... 00E800
    FRU Number:..... 00E800
    Serial Number:..... TL30025900m
    Manufacturer ID:..... 0080
    ED Level:..... 0
    ROM Level (alterable):..... 01E000a5
    Customer Card ID Number:..... 5763
    Product Specific (1):..... 5
    Product Specific (2):..... 5
    Feature Code/Marketing ID:..... 5888-001
    Machine/Cabinet Serial No.:..... 021D000
    FRU Label:..... P1-C3-T1
    Hardware Location Code:..... U204E 001 DBJ0634-P1-C3-T1-L1-T1
(0) root # Y0562p1 : /
#

```

2. Find the **FRU Label** field in the controller VPD, which is the ERM physical location code within the Feature Code/Marketing ID and the Machine/Cabinet Serial No. shown in the command output.

Finding the port of the GX adapter

Find the port on the GX adapter in the system unit that is identified by the RAID controller logical location code (the `-Ty` in the example `Utttt.mmm.ssssss-Pw-Cx-Ty-L1(-T1)`). Trace the cable from that port to the PCIe storage enclosure to identify the physical ERM. You can also use the Advanced System Management Interface (ASMI) to identify the light-emitting diode (LED) for the ERM.

Using the operating system tools

Use the operating system tools to find the serial-attached SCSI (SAS) Enclosure Services (SES) resource that has the same serial number as the RAID controller. After the matching SES is found, the hardware location code in the SES vital product data (VPD) is the ERM physical location code that corresponds to the RAID controller.

An example of finding the physical location for RAID controller resource to be replaced (sissas2 in this example) follows:

1. Use the AIX `sissasraidmgr` command to find all the SES resources connected to the specified RAID controller:

```
# sissasraidmgr -l1 sissas2 -j3
```

Information similar to the following is displayed:

```

root@Y0262p1: /
# sissasraidmgr -l1 sissas2 -j3
-----
Name      Resource State      Description      Size
-----
sissas1  FFFFFFFF Primary PCI#2 3 10b Cache RAID SAS Enclosure 60b x8
sissas2  FFFFFFFF HA Linfeed Remote adapter SM 0025900H
-----
hdisk1   FC0000FF Optimal RAID 0 Array (0/0) 387.90B
pdisk0   000000FF Active SSD Array Member
-----
hdisk2   FC0000FF Optimal RAID 0 Array (N/N) 387.90B
pdisk1   000001FF Active SSD Array Member
-----
hdisk3   FC0000FF Optimal RAID 0 Array (0/0) 387.90B
pdisk3   000000FF Active SSD Array Member
-----
hdisk4   FC0000FF Optimal RAID 0 Array (N/N) 387.90B
pdisk4   000004FF Active SSD Array Member
-----
hdisk5   FC0400FF Optimal RAID 0 Array (0/0) 387.90B
pdisk5   000005FF Active SSD Array Member
-----
hdisk6   FC0500FF Optimal RAID 0 Array (N/N) 387.90B
pdisk6   000006FF Active SSD Array Member
-----
hdisk7   FC0600FF Optimal RAID 0 Array (0/0) 387.90B
pdisk7   000007FF Active SSD Array Member
-----
hdisk8   FC0700FF Optimal RAID 0 Array (N/N) 387.90B
pdisk8   000008FF Active SSD Array Member
-----
ses2     000000FF Available SAS Enclosure Service N/A
ses3     000400FF Available SAS Enclosure Service N/A
masc010  F00000FF Available SAS I/O Controller In N/A

```

2. Use the AIX `lscfg` command to find the serial number of the RAID controller:

```
lscfg -v1 sissas2
```

Information similar to the following is displayed:

```

root@Y0262p1: /
# lscfg -v1 sissas2
-----
PCI#2 3 10b Cache RAID SAS Enclosure 60b x8
-----
PCIC2 3 10b Cache RAID SAS Enclosure 60b x8 :
Part Number ..... 0068807
FPU Number ..... 0068005
Serial Number ..... YL30B025900H
Manufacture ID ..... 0060
EG Level ..... 0
ROM Level (alterable) ..... 015000a5
Customer Card ID Number ..... 5763
Product Specific (C1) ..... 5
Product Specific (C2) ..... 2024
Feature Code/Marketing ID ..... 5888-001
Machine/Cabinet Serial No. .... 021000U
FPU Label ..... F1-C2-E3
Hardware Location Code ..... U2C4E 001 DB70634-P1-03-T1-L1-T1

```

3. Use the AIX `lscfg` command to find which SES serial number matches the RAID controller serial number:

```
lscfg -v1 ses3
```

Information similar to the following is displayed:

```

root@Y0262p1: /
# lscfg -v1 ses3
-----
SAS Expander:
FPU Number ..... 0068805
Serial Number ..... YL30B025900H
Customer Card ID Number ..... 5763
ROM Level (alterable) ..... 6745
Hardware Location Code ..... US888 001 021000U-P1-02
-----

```

4. Use the hardware location code in the matching SES to identify the physical location of the RAID controller.

Determining the ERM location from the RAID controller location when using IBM i:

Learn how to use the IBM i operating system to determine the physical location of the RAID controller on the enclosure RAID module (ERM) when you have the RAID controller logical location.

Use one of the following methods to determine the RAID controller physical location:

- “Finding the port of the GX adapter” on page 38
- “Using the operating system tools” on page 38

Finding the port of the GX adapter

Find the port on the GX adapter in the system unit that is identified by the RAID controller logical location code (the `-Ty` in the example `Utttt.mmm.ssssss-Pw-Cx-Ty-L1(-T1)`). Trace the cable from that port to the PCIe storage enclosure to identify the physical ERM. You can also use the Advanced System Management Interface (ASMI) to identify the light-emitting diode (LED) for the ERM.

Using the operating system tools

Use the operating system tools to find the serial-attached SCSI (SAS) enclosure service (SES) resource that has the same serial number as the RAID controller. After the matching SES is found, the hardware location code in the SES vital product data (VPD) is the ERM physical location code that corresponds to the RAID controller.

The packaging hardware resources option in hardware service manager (HSM) is used to locate the packaging resource that has the logical slot location code of the RAID controller.

An example of determining which ERM to replace by finding the physical location for the RAID controller resource follows:

1. Log in with service level authority.
2. On the command line of the IBM i session, type `strsst` and press Enter.
3. Type your service tools user ID and service tools password on the System Service Tools (SST) Sign On display and press Enter.

Note: The service tools password is case-sensitive.

4. Select **Start a service tool** from the System Service Tools (SST) display and press Enter.
5. Select **Hardware service manager** from the Start a Service Tool display and press Enter.
6. From the HSM, select option 1 to display packaging hardware resources and press Enter.
7. Type option 9 to show the hardware that is contained within the package for the system unit resource, which contains the logical slot for the RAID controller. Press Enter.
8. Type option 8 to select the associated logical resources for the RAID controller resource that has the logical location code you are working with to find the logical resource name of the virtual I/O processor (IOP) resource. Press Enter.
9. Record the logical resource name of the virtual IOP resource.
10. Return to the HSM main menu and select option 2 to show the logical hardware resources and press Enter.
11. Select option 1 to show the system bus resources and press Enter.
12. Locate the logical resource name of the virtual IOP resource from step 9. Type option 9 to show the resources that are associated with this virtual IOP. Press Enter.
13. Select option F11 to display the serial and part numbers.
14. Locate the device services resource that has the same serial number and part number as the virtual IOP resource. Type option 8 to display the associated packaging resources for the selected device services. Press Enter.
15. Type option 5 to display the details of the device services resource. Press Enter.
16. Use the information on the Packaging Hardware Resource Detail display to determine the ERM physical location that corresponds to the RAID controller.

Determining the ERM location from the RAID controller location when using Linux:

Learn how to use the Linux operating system to determine the physical location of the RAID controller on the enclosure RAID module (ERM) when you have the RAID controller logical location code.

Use one of the following methods to determine the RAID controller physical location:

- “Finding the port of the GX adapter”
- “Using the operating system tools”

Finding the port of the GX adapter

Find the port on the GX adapter in the system unit that is identified by the RAID controller logical location code (the `-Ty` in the example `Utttt.mmm.ssssss-Pw-Cx-Ty-L1(-T1)`). Trace the cable from that port to the PCIe storage enclosure to identify the physical ERM. You can also use the Advanced System Management Interface (ASMI) to identify the light-emitting diode (LED) for the ERM.

Using the operating system tools

Use the operating system tools to find the serial-attached SCSI (SAS) enclosure service (SES) resource that has the same serial number as the RAID controller. After the matching SES is found, the hardware location code in the SES vital product data (VPD) is the ERM physical location code that corresponds to the RAID controller.

An example of finding the physical location for the RAID controller resource to be replaced follows:

1. Type `iprconfig` on the command line of the Linux session and press Enter. The IBM Power RAID Configuration Utility display is shown.
2. Select **Work with disk unit recovery** from the IBM Power RAID Configuration Utility display, and press Enter.
3. Select **Work with disk enclosures** from the Work with Disk Unit Recovery display, and press Enter. Information similar to the following is shown for display 1:

```

root@sw9:~# iprconfig
Work with disk enclosures

Type options, press Enter
1)Display disk enclosure details
2)Suspend disk enclosure path
3)Resume disk enclosure path

OPT Name FC1/Host/Resource Path Serial Number Status
-----
[ ] s921 0000:01:00_001 VL108C21700X Operational
[ ] s910 0000:01:00_0/1/00-04-2C VL108C212004 Active
[ ] s91 0000:01:00_0/2/00-00-2C VL108C21700X Active
[ ] s942 0001:01:00_0/2 VL108C212004 Operational
[ ] s92 0005:01:00_0/2/00-04-2C VL108C212004 Active
[ ] s923 0001:01:00_0/2/00-04-2C VL108C21700X Active

#Exit #Cancel t=Toggle
  
```

4. Type `t` to toggle to the next display. Information similar to the following is shown for display 2:

```

root@sw9:~# iprconfig
Work with disk enclosures

Type options, press Enter
1)Display disk enclosure details
2)Suspend disk enclosure path
3)Resume disk enclosure path

OPT Name Physical Location Production ID Status
-----
[ ] s921 UC43_001_1818925-P1-C3-T2-L1 57C3001515104 Operational
[ ] s920 US888_001_0227009-P1-C1 9088 Active
[ ] s91 US888_001_0227009-P1-C1 9088 Active
[ ] s942 UC43_001_1818925-P1-C3-T1-L1 57C3001515104 Operational
[ ] s92 US888_001_0227009-P1-C1 9088 Active
[ ] s923 US888_001_0227009-P1-C1 9088 Active

#Exit #Cancel t=Toggle
  
```

5. Use display 1 to find the serial number of the RAID controller.
6. Use display 1 to find which SES serial number matches the serial number of the RAID controller. Each RAID controller has two SES entries.
7. Use the matching SES in display 1 to find the physical location of the RAID controller in display 2.

Updating microcode for PCIe storage enclosure components

The 5888 or EDR1 PCIe storage enclosure has hardware components that require microcode updates.

The following hardware components can be updated concurrently:

- The solid-state drives (SSD) of the SSD assemblies

- The SAS expander of the enclosure RAID module (ERM)
- The PCIe RAID adapter of the ERM

To update the microcode for the PCIe storage enclosure hardware components, see [Updating the SAS RAID controller microcode](#).

FRUs for the 5888 or EDR1 PCIe storage enclosure

Some parts of the IBM EXP 30 Ultra I/O Drawer are field replaceable units (FRUs). Most of these parts are concurrently maintainable.

The FRUs include the following parts:

- Solid-state drive (SSD) assembly
- Enclosure RAID module (ERM)
- ERM fan assembly
- Midplane
- Power supply
- PCIe cable

Use Table 2 to find specific information that is helpful for removing and replacing FRUs in the PCIe storage enclosure you are working with.

Table 2. References for PCIe storage enclosures

Referenced information	5888 or EDR1 PCIe storage enclosure
System parts	System parts
Part locations and location codes	Locations
Device addresses	Device addresses
FRU removal and replacement procedures	5888 PCIe storage enclosure removal and replacement procedures and EDR1 PCIe storage enclosure removal and replacement procedures
Connector locations	5888 connector locations and EDR1 connector locations

Identifying a SAS fabric FRU for the 5888 or EDR1 PCIe storage enclosure

Multiple isolation procedures are available for errors logged by the RAID controller in the enclosure RAID module (ERM) that are caused by a failing connection or component in the serial-attached SCSI (SAS) fabric.

Follow the isolation procedures carefully and use this procedure only when directed to do so by the isolation procedure.

These isolation procedures might require reseating or replacing the ERM, midplane assembly, or device. Pay careful attention to the 5888 or EDR1 SAS resource location information when identifying the possible causes from the isolation procedure that sent you here. Also note that the isolation procedure might specify either that the RAID controller or disk drive are not likely the cause and therefore another possible component must be tried.

Use Table 3 on page 41 to correlate a component described in the isolation procedure to the possible FRU in the 5888 or EDR1 PCIe storage enclosure that contains the component.

Table 3. Isolation procedure component with FRU name and location

Isolation procedure component	5888 or EDR1 FRU	5888 or EDR1 location
SAS controller	ERM assembly	U5888.001.ssssss-P1-Cx
SAS cable	ERM assembly	U5888.001.ssssss-P1-Cx
Device enclosure	Midplane assembly	U5888.001.ssssss-P1
SAS expander	ERM assembly	U5888.001.ssssss-P1-Cx
Disk drive	Solid-state drive (SSD) assembly	U5888.001.ssssss-P1-Dx

Note: It is important to determine which of the redundant ERMs is the cause of a problem. To determine the ERM physical location to ensure that the correct physical components are identified. See “RAID controller location code” on page 35.

Storage enclosure topology

Find information to help you locate components within the 5888 or EDR1 PCIe storage enclosure.

Figure 41 shows the location of components within the 5888 or EDR1 PCIe storage enclosure.

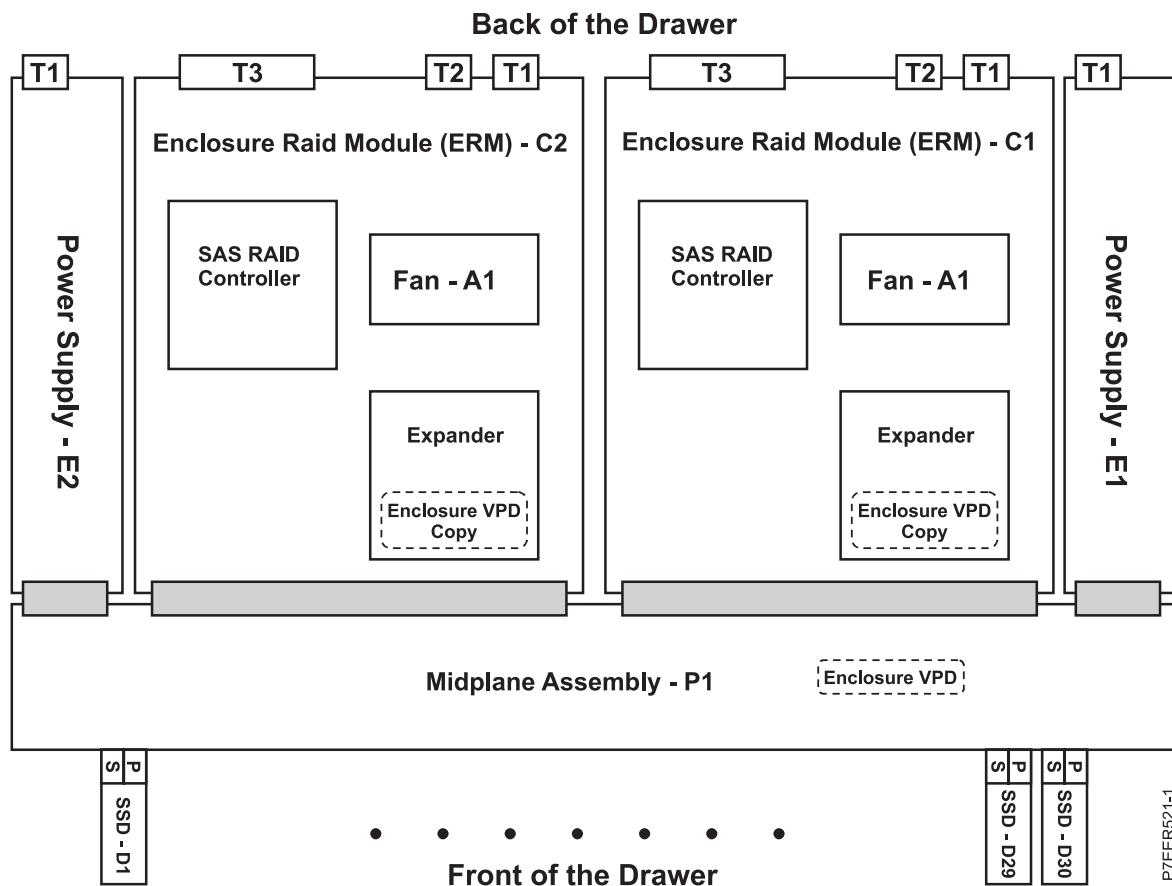

Figure 41. Component locations

Figure 42 on page 42 shows the SAS physical links and device interfaces (PHY) of components within the 5888 or EDR1 PCIe storage enclosure.

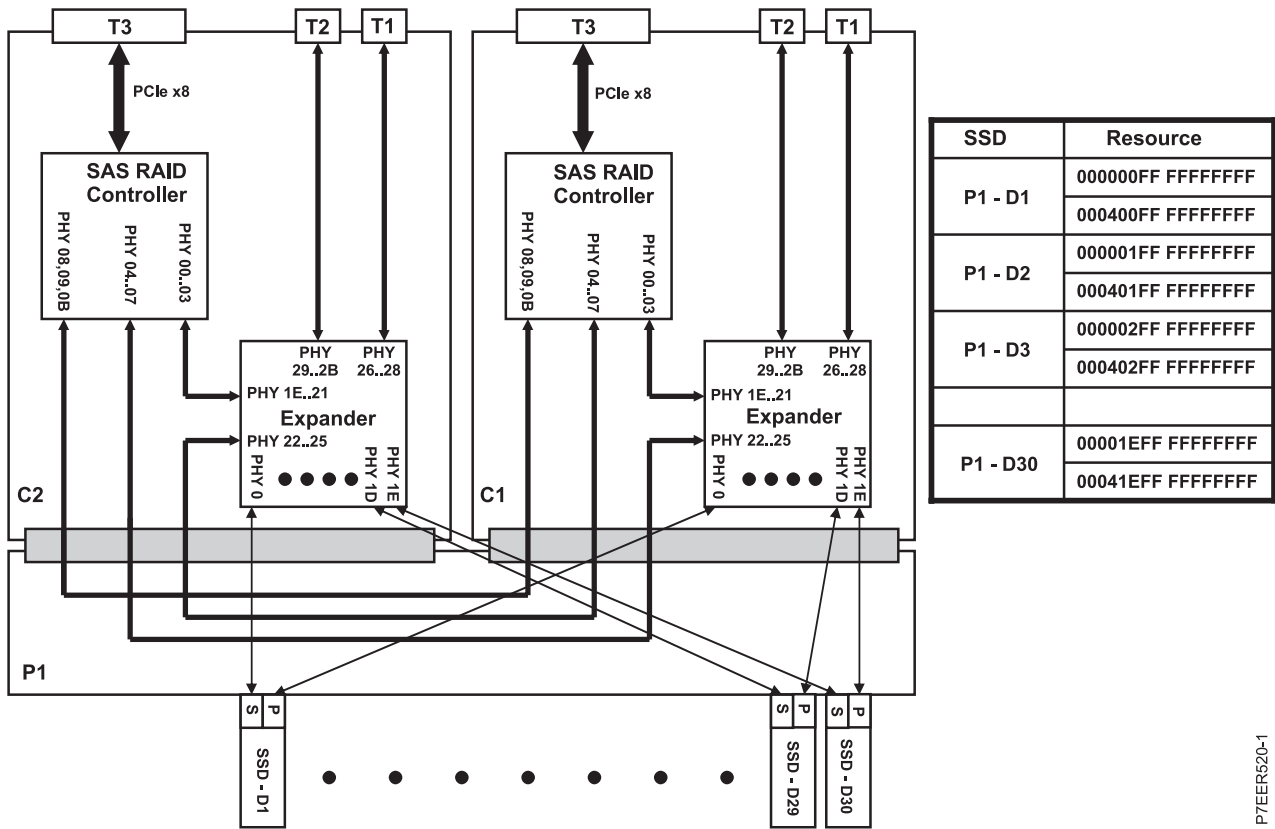

Figure 42. SAS physical links and device interfaces

P7EER520-1

Notices

This information was developed for products and services offered in the U.S.A.

The manufacturer may not offer the products, services, or features discussed in this document in other countries. Consult the manufacturer's representative for information on the products and services currently available in your area. Any reference to the manufacturer's product, program, or service is not intended to state or imply that only that product, program, or service may be used. Any functionally equivalent product, program, or service that does not infringe any intellectual property right of the manufacturer may be used instead. However, it is the user's responsibility to evaluate and verify the operation of any product, program, or service.

The manufacturer may have patents or pending patent applications covering subject matter described in this document. The furnishing of this document does not grant you any license to these patents. You can send license inquiries, in writing, to the manufacturer.

The following paragraph does not apply to the United Kingdom or any other country where such provisions are inconsistent with local law: THIS PUBLICATION IS PROVIDED "AS IS" WITHOUT WARRANTY OF ANY KIND, EITHER EXPRESS OR IMPLIED, INCLUDING, BUT NOT LIMITED TO, THE IMPLIED WARRANTIES OF NON-INFRINGEMENT, MERCHANTABILITY OR FITNESS FOR A PARTICULAR PURPOSE. Some states do not allow disclaimer of express or implied warranties in certain transactions, therefore, this statement may not apply to you.

This information could include technical inaccuracies or typographical errors. Changes are periodically made to the information herein; these changes will be incorporated in new editions of the publication. The manufacturer may make improvements and/or changes in the product(s) and/or the program(s) described in this publication at any time without notice.

Any references in this information to websites not owned by the manufacturer are provided for convenience only and do not in any manner serve as an endorsement of those websites. The materials at those websites are not part of the materials for this product and use of those websites is at your own risk.

The manufacturer may use or distribute any of the information you supply in any way it believes appropriate without incurring any obligation to you.

Any performance data contained herein was determined in a controlled environment. Therefore, the results obtained in other operating environments may vary significantly. Some measurements may have been made on development-level systems and there is no guarantee that these measurements will be the same on generally available systems. Furthermore, some measurements may have been estimated through extrapolation. Actual results may vary. Users of this document should verify the applicable data for their specific environment.

Information concerning products not produced by this manufacturer was obtained from the suppliers of those products, their published announcements or other publicly available sources. This manufacturer has not tested those products and cannot confirm the accuracy of performance, compatibility or any other claims related to products not produced by this manufacturer. Questions on the capabilities of products not produced by this manufacturer should be addressed to the suppliers of those products.

All statements regarding the manufacturer's future direction or intent are subject to change or withdrawal without notice, and represent goals and objectives only.

The manufacturer's prices shown are the manufacturer's suggested retail prices, are current and are subject to change without notice. Dealer prices may vary.

This information is for planning purposes only. The information herein is subject to change before the products described become available.

This information contains examples of data and reports used in daily business operations. To illustrate them as completely as possible, the examples include the names of individuals, companies, brands, and products. All of these names are fictitious and any similarity to the names and addresses used by an actual business enterprise is entirely coincidental.

If you are viewing this information in softcopy, the photographs and color illustrations may not appear.

The drawings and specifications contained herein shall not be reproduced in whole or in part without the written permission of the manufacturer.

The manufacturer has prepared this information for use with the specific machines indicated. The manufacturer makes no representations that it is suitable for any other purpose.

The manufacturer's computer systems contain mechanisms designed to reduce the possibility of undetected data corruption or loss. This risk, however, cannot be eliminated. Users who experience unplanned outages, system failures, power fluctuations or outages, or component failures must verify the accuracy of operations performed and data saved or transmitted by the system at or near the time of the outage or failure. In addition, users must establish procedures to ensure that there is independent data verification before relying on such data in sensitive or critical operations. Users should periodically check the manufacturer's support websites for updated information and fixes applicable to the system and related software.

Homologation statement

This product may not be certified in your country for connection by any means whatsoever to interfaces of public telecommunications networks. Further certification may be required by law prior to making any such connection. Contact an IBM representative or reseller for any questions.

Trademarks

IBM, the IBM logo, and ibm.com are trademarks or registered trademarks of International Business Machines Corp., registered in many jurisdictions worldwide. Other product and service names might be trademarks of IBM or other companies. A current list of IBM trademarks is available on the web at Copyright and trademark information at www.ibm.com/legal/copytrade.shtml.

Linux is a registered trademark of Linus Torvalds in the United States, other countries, or both.

Electronic emission notices

When attaching a monitor to the equipment, you must use the designated monitor cable and any interference suppression devices supplied with the monitor.

Class A Notices

The following Class A statements apply to the IBM servers that contain the POWER7 processor and its features unless designated as electromagnetic compatibility (EMC) Class B in the feature information.

Federal Communications Commission (FCC) statement

Note: This equipment has been tested and found to comply with the limits for a Class A digital device, pursuant to Part 15 of the FCC Rules. These limits are designed to provide reasonable protection against harmful interference when the equipment is operated in a commercial environment. This equipment generates, uses, and can radiate radio frequency energy and, if not installed and used in accordance with

the instruction manual, may cause harmful interference to radio communications. Operation of this equipment in a residential area is likely to cause harmful interference, in which case the user will be required to correct the interference at his own expense.

Properly shielded and grounded cables and connectors must be used in order to meet FCC emission limits. IBM is not responsible for any radio or television interference caused by using other than recommended cables and connectors or by unauthorized changes or modifications to this equipment. Unauthorized changes or modifications could void the user's authority to operate the equipment.

This device complies with Part 15 of the FCC rules. Operation is subject to the following two conditions: (1) this device may not cause harmful interference, and (2) this device must accept any interference received, including interference that may cause undesired operation.

Industry Canada Compliance Statement

This Class A digital apparatus complies with Canadian ICES-003.

Avis de conformité à la réglementation d'Industrie Canada

Cet appareil numérique de la classe A est conforme à la norme NMB-003 du Canada.

European Community Compliance Statement

This product is in conformity with the protection requirements of EU Council Directive 2004/108/EC on the approximation of the laws of the Member States relating to electromagnetic compatibility. IBM cannot accept responsibility for any failure to satisfy the protection requirements resulting from a non-recommended modification of the product, including the fitting of non-IBM option cards.

This product has been tested and found to comply with the limits for Class A Information Technology Equipment according to European Standard EN 55022. The limits for Class A equipment were derived for commercial and industrial environments to provide reasonable protection against interference with licensed communication equipment.

European Community contact:
IBM Deutschland GmbH
Technical Regulations, Department M372
IBM-Allee 1, 71139 Ehningen, Germany
Tele: +49 7032 15 2941
email: lugi@de.ibm.com

Warning: This is a Class A product. In a domestic environment, this product may cause radio interference, in which case the user may be required to take adequate measures.

VCCI Statement - Japan

この装置は、クラスA 情報技術装置です。この装置を家庭環境で使用すると電波妨害を引き起こすことがあります。この場合には使用者が適切な対策を講ずるよう要求されることがあります。

VCCI-A

The following is a summary of the VCCI Japanese statement in the box above:

This is a Class A product based on the standard of the VCCI Council. If this equipment is used in a domestic environment, radio interference may occur, in which case, the user may be required to take corrective actions.

Japanese Electronics and Information Technology Industries Association (JEITA) Confirmed Harmonics Guideline (products less than or equal to 20 A per phase)

高調波ガイドライン適合品

Japanese Electronics and Information Technology Industries Association (JEITA) Confirmed Harmonics Guideline with Modifications (products greater than 20 A per phase)

高調波ガイドライン準用品

Electromagnetic Interference (EMI) Statement - People's Republic of China

声 明

此为 A 级产品,在生活环境
中,该产品可能会造成无线电干
扰。在这种情况下,可能需要用
户对其干扰采取切实可行的措
施。

Declaration: This is a Class A product. In a domestic environment this product may cause radio interference in which case the user may need to perform practical action.

Electromagnetic Interference (EMI) Statement - Taiwan

警告使用者：

這是甲類的資訊產品，在居住的環境中使用時，可能會造成射頻干擾，在這種情況下，使用者會被要求採取某些適當的對策。

The following is a summary of the EMI Taiwan statement above.

Warning: This is a Class A product. In a domestic environment this product may cause radio interference in which case the user will be required to take adequate measures.

IBM Taiwan Contact Information:

台灣IBM 產品服務聯絡方式：
台灣國際商業機器股份有限公司
台北市松仁路7號3樓
電話：0800-016-888

Electromagnetic Interference (EMI) Statement - Korea

이 기기는 업무용(A급)으로 전자파적합기기로서 판매자 또는 사용자는 이 점을 주의하시기 바라며, 가정외의 지역에서 사용하는 것을 목적으로 합니다.

Germany Compliance Statement

Deutschsprachiger EU Hinweis: Hinweis für Geräte der Klasse A EU-Richtlinie zur Elektromagnetischen Verträglichkeit

Dieses Produkt entspricht den Schutzanforderungen der EU-Richtlinie 2004/108/EG zur Angleichung der Rechtsvorschriften über die elektromagnetische Verträglichkeit in den EU-Mitgliedsstaaten und hält die Grenzwerte der EN 55022 Klasse A ein.

Um dieses sicherzustellen, sind die Geräte wie in den Handbüchern beschrieben zu installieren und zu betreiben. Des Weiteren dürfen auch nur von der IBM empfohlene Kabel angeschlossen werden. IBM übernimmt keine Verantwortung für die Einhaltung der Schutzanforderungen, wenn das Produkt ohne Zustimmung von IBM verändert bzw. wenn Erweiterungskomponenten von Fremdherstellern ohne Empfehlung von IBM gesteckt/eingebaut werden.

EN 55022 Klasse A Geräte müssen mit folgendem Warnhinweis versehen werden:

"Warnung: Dieses ist eine Einrichtung der Klasse A. Diese Einrichtung kann im Wohnbereich Funk-Störungen verursachen; in diesem Fall kann vom Betreiber verlangt werden, angemessene Maßnahmen zu ergreifen und dafür aufzukommen."

Deutschland: Einhaltung des Gesetzes über die elektromagnetische Verträglichkeit von Geräten

Dieses Produkt entspricht dem "Gesetz über die elektromagnetische Verträglichkeit von Geräten (EMVG)". Dies ist die Umsetzung der EU-Richtlinie 2004/108/EG in der Bundesrepublik Deutschland.

Zulassungsbescheinigung laut dem Deutschen Gesetz über die elektromagnetische Verträglichkeit von Geräten (EMVG) (bzw. der EMC EG Richtlinie 2004/108/EG) für Geräte der Klasse A

Dieses Gerät ist berechtigt, in Übereinstimmung mit dem Deutschen EMVG das EG-Konformitätszeichen - CE - zu führen.

Verantwortlich für die Einhaltung der EMV Vorschriften ist der Hersteller:
International Business Machines Corp.
New Orchard Road
Armonk, New York 10504
Tel: 914-499-1900

Der verantwortliche Ansprechpartner des Herstellers in der EU ist:
IBM Deutschland GmbH
Technical Regulations, Abteilung M372
IBM-Allee 1, 71139 Ehningen, Germany
Tel: +49 7032 15 2941
email: lugi@de.ibm.com

Generelle Informationen:

Das Gerät erfüllt die Schutzanforderungen nach EN 55024 und EN 55022 Klasse A.

Electromagnetic Interference (EMI) Statement - Russia

ВНИМАНИЕ! Настоящее изделие относится к классу А.
В жилых помещениях оно может создавать
радиопомехи, для снижения которых необходимы
дополнительные меры

Class B Notices

The following Class B statements apply to features designated as electromagnetic compatibility (EMC) Class B in the feature installation information.

Federal Communications Commission (FCC) statement

This equipment has been tested and found to comply with the limits for a Class B digital device, pursuant to Part 15 of the FCC Rules. These limits are designed to provide reasonable protection against harmful interference in a residential installation.

This equipment generates, uses, and can radiate radio frequency energy and, if not installed and used in accordance with the instructions, may cause harmful interference to radio communications. However, there is no guarantee that interference will not occur in a particular installation.

If this equipment does cause harmful interference to radio or television reception, which can be determined by turning the equipment off and on, the user is encouraged to try to correct the interference by one or more of the following measures:

- Reorient or relocate the receiving antenna.
- Increase the separation between the equipment and receiver.
- Connect the equipment into an outlet on a circuit different from that to which the receiver is connected.
- Consult an IBM-authorized dealer or service representative for help.

Properly shielded and grounded cables and connectors must be used in order to meet FCC emission limits. Proper cables and connectors are available from IBM-authorized dealers. IBM is not responsible for

any radio or television interference caused by unauthorized changes or modifications to this equipment. Unauthorized changes or modifications could void the user's authority to operate this equipment.

This device complies with Part 15 of the FCC rules. Operation is subject to the following two conditions: (1) this device may not cause harmful interference, and (2) this device must accept any interference received, including interference that may cause undesired operation.

Industry Canada Compliance Statement

This Class B digital apparatus complies with Canadian ICES-003.

Avis de conformité à la réglementation d'Industrie Canada

Cet appareil numérique de la classe B est conforme à la norme NMB-003 du Canada.

European Community Compliance Statement

This product is in conformity with the protection requirements of EU Council Directive 2004/108/EC on the approximation of the laws of the Member States relating to electromagnetic compatibility. IBM cannot accept responsibility for any failure to satisfy the protection requirements resulting from a non-recommended modification of the product, including the fitting of non-IBM option cards.

This product has been tested and found to comply with the limits for Class B Information Technology Equipment according to European Standard EN 55022. The limits for Class B equipment were derived for typical residential environments to provide reasonable protection against interference with licensed communication equipment.

European Community contact:
IBM Deutschland GmbH
Technical Regulations, Department M372
IBM-Allee 1, 71139 Ehningen, Germany
Tele: +49 7032 15 2941
email: lugi@de.ibm.com

VCCI Statement - Japan

この装置は、クラスB情報技術装置です。この装置は、家庭環境で使用することを目的としていますが、この装置がラジオやテレビジョン受信機に近接して使用されると、受信障害を引き起こすことがあります。

取扱説明書に従って正しい取り扱いをして下さい。 VCCI-B

Japanese Electronics and Information Technology Industries Association (JEITA) Confirmed Harmonics Guideline (products less than or equal to 20 A per phase)

高調波ガイドライン適合品

**Japanese Electronics and Information Technology Industries Association (JEITA)
Confirmed Harmonics Guideline with Modifications (products greater than 20 A per
phase)**

高調波ガイドライン準用品

IBM Taiwan Contact Information

台灣IBM 產品服務聯絡方式：
台灣國際商業機器股份有限公司
台北市松仁路7號3樓
電話：0800-016-888

Electromagnetic Interference (EMI) Statement - Korea

이 기기는 가정용(B급)으로 전자파적합기기로서 주로 가정에서 사용하는 것을 목적으로 하며, 모든 지역에서 사용할 수 있습니다.

Germany Compliance Statement

**Deutschsprachiger EU Hinweis: Hinweis für Geräte der Klasse B EU-Richtlinie zur
Elektromagnetischen Verträglichkeit**

Dieses Produkt entspricht den Schutzanforderungen der EU-Richtlinie 2004/108/EG zur Angleichung der Rechtsvorschriften über die elektromagnetische Verträglichkeit in den EU-Mitgliedsstaaten und hält die Grenzwerte der EN 55022 Klasse B ein.

Um dieses sicherzustellen, sind die Geräte wie in den Handbüchern beschrieben zu installieren und zu betreiben. Des Weiteren dürfen auch nur von der IBM empfohlene Kabel angeschlossen werden. IBM übernimmt keine Verantwortung für die Einhaltung der Schutzanforderungen, wenn das Produkt ohne Zustimmung von IBM verändert bzw. wenn Erweiterungskomponenten von Fremdherstellern ohne Empfehlung von IBM gesteckt/eingebaut werden.

Deutschland: Einhaltung des Gesetzes über die elektromagnetische Verträglichkeit von Geräten

Dieses Produkt entspricht dem "Gesetz über die elektromagnetische Verträglichkeit von Geräten (EMVG)". Dies ist die Umsetzung der EU-Richtlinie 2004/108/EG in der Bundesrepublik Deutschland.

**Zulassungsbescheinigung laut dem Deutschen Gesetz über die elektromagnetische Verträglichkeit von
Geräten (EMVG) (bzw. der EMC EG Richtlinie 2004/108/EG) für Geräte der Klasse B**

Dieses Gerät ist berechtigt, in Übereinstimmung mit dem Deutschen EMVG das EG-Konformitätszeichen - CE - zu führen.

Verantwortlich für die Einhaltung der EMV Vorschriften ist der Hersteller:
International Business Machines Corp.
New Orchard Road
Armonk, New York 10504
Tel: 914-499-1900

Der verantwortliche Ansprechpartner des Herstellers in der EU ist:
IBM Deutschland GmbH
Technical Regulations, Abteilung M372
IBM-Allee 1, 71139 Ehningen, Germany
Tel: +49 7032 15 2941
email: lugi@de.ibm.com

Generelle Informationen:

Das Gerät erfüllt die Schutzanforderungen nach EN 55024 und EN 55022 Klasse B.

Terms and conditions

Permissions for the use of these publications are granted subject to the following terms and conditions.

Applicability: These terms and conditions are in addition to any terms of use for the IBM website.

Personal Use: You may reproduce these publications for your personal, noncommercial use provided that all proprietary notices are preserved. You may not distribute, display or make derivative works of these publications, or any portion thereof, without the express consent of IBM.

Commercial Use: You may reproduce, distribute and display these publications solely within your enterprise provided that all proprietary notices are preserved. You may not make derivative works of these publications, or reproduce, distribute or display these publications or any portion thereof outside your enterprise, without the express consent of IBM.

Rights: Except as expressly granted in this permission, no other permissions, licenses or rights are granted, either express or implied, to the Publications or any information, data, software or other intellectual property contained therein.

IBM reserves the right to withdraw the permissions granted herein whenever, in its discretion, the use of the publications is detrimental to its interest or, as determined by IBM, the above instructions are not being properly followed.

You may not download, export or re-export this information except in full compliance with all applicable laws and regulations, including all United States export laws and regulations.

IBM MAKES NO GUARANTEE ABOUT THE CONTENT OF THESE PUBLICATIONS. THE PUBLICATIONS ARE PROVIDED "AS-IS" AND WITHOUT WARRANTY OF ANY KIND, EITHER EXPRESSED OR IMPLIED, INCLUDING BUT NOT LIMITED TO IMPLIED WARRANTIES OF MERCHANTABILITY, NON-INFRINGEMENT, AND FITNESS FOR A PARTICULAR PURPOSE.



Printed in USA