

Power Systems

*Installing the EDR1  
PCIe storage enclosure*





Power Systems

*Installing the EDR1  
PCIe storage enclosure*



**Note**

Before using this information and the product it supports, read the information in "Safety notices" on page v, "Notices" on page 43, the *IBM Systems Safety Notices* manual, G229-9054, and the *IBM Environmental Notices and User Guide*, Z125-5823.

This edition applies to IBM Power Systems™ servers that contain the POWER7 processor and to all associated models.

© Copyright IBM Corporation 2012, 2013.

US Government Users Restricted Rights – Use, duplication or disclosure restricted by GSA ADP Schedule Contract with IBM Corp.

---

# Contents

<b>Safety notices</b> . . . . .	<b>v</b>
<b>Installing the EDR1 PCIe storage enclosure</b> . . . . .	<b>1</b>
<b>Installing the EDR1 PCIe storage enclosure: Details.</b> . . . . .	<b>3</b>
<b>Reference information</b> . . . . .	<b>21</b>
Connector locations. . . . .	21
Server connectors . . . . .	21
Model 8202-E4D connector locations . . . . .	21
Model 8205-E6D connector locations . . . . .	21
Model 8231-E1D or 8268-E1D connector locations. . . . .	22
Model 8231-E2D connector locations . . . . .	23
Model 8248-L4T, 8408-E8D, or 9109-RMD connector locations. . . . .	24
Model 8412-EAD connector locations . . . . .	25
Model 9117-MMD or 9179-MHD connector locations . . . . .	25
Enclosure connectors . . . . .	26
Model EDR1 connector locations . . . . .	26
Model 5887 connector locations. . . . .	27
Cabling the PCIe storage enclosure . . . . .	27
Cabling the EDR1 PCIe storage enclosure to an 8202-E4D or 8205-E6D system . . . . .	27
Cabling the EDR1 PCIe storage enclosure to an 8231-E1D, 8231-E2D, or 8268-E1D system . . . . .	31
Cabling the EDR1 PCIe storage enclosure to an 8246-L2T system . . . . .	34
Cabling the EDR1 PCIe storage enclosure to an 8248-L4T, 8408-E8D, or 9109-RMD system . . . . .	36
Cabling the EDR1 PCIe storage enclosure to an 8412-EAD, 9117-MMC, 9117-MMD, 9179-MHC, or 9179-MHD system . . . . .	38
<b>Notices</b> . . . . .	<b>43</b>
Trademarks . . . . .	44
Electronic emission notices . . . . .	44
Class A Notices . . . . .	44
Class B Notices . . . . .	48
Terms and conditions . . . . .	51



---

## Safety notices

Safety notices may be printed throughout this guide:

- **DANGER** notices call attention to a situation that is potentially lethal or extremely hazardous to people.
- **CAUTION** notices call attention to a situation that is potentially hazardous to people because of some existing condition.
- **Attention** notices call attention to the possibility of damage to a program, device, system, or data.

### World Trade safety information

Several countries require the safety information contained in product publications to be presented in their national languages. If this requirement applies to your country, safety information documentation is included in the publications package (such as in printed documentation, on DVD, or as part of the product) shipped with the product. The documentation contains the safety information in your national language with references to the U.S. English source. Before using a U.S. English publication to install, operate, or service this product, you must first become familiar with the related safety information documentation. You should also refer to the safety information documentation any time you do not clearly understand any safety information in the U.S. English publications.

Replacement or additional copies of safety information documentation can be obtained by calling the IBM Hotline at 1-800-300-8751.

### German safety information

Das Produkt ist nicht für den Einsatz an Bildschirmarbeitsplätzen im Sinne § 2 der Bildschirmarbeitsverordnung geeignet.

### Laser safety information

IBM® servers can use I/O cards or features that are fiber-optic based and that utilize lasers or LEDs.

### Laser compliance

IBM servers may be installed inside or outside of an IT equipment rack.

## DANGER

When working on or around the system, observe the following precautions:

Electrical voltage and current from power, telephone, and communication cables are hazardous. To avoid a shock hazard:

- Connect power to this unit only with the IBM provided power cord. Do not use the IBM provided power cord for any other product.
- Do not open or service any power supply assembly.
- Do not connect or disconnect any cables or perform installation, maintenance, or reconfiguration of this product during an electrical storm.
- The product might be equipped with multiple power cords. To remove all hazardous voltages, disconnect all power cords.
- Connect all power cords to a properly wired and grounded electrical outlet. Ensure that the outlet supplies proper voltage and phase rotation according to the system rating plate.
- Connect any equipment that will be attached to this product to properly wired outlets.
- When possible, use one hand only to connect or disconnect signal cables.
- Never turn on any equipment when there is evidence of fire, water, or structural damage.
- Disconnect the attached power cords, telecommunications systems, networks, and modems before you open the device covers, unless instructed otherwise in the installation and configuration procedures.
- Connect and disconnect cables as described in the following procedures when installing, moving, or opening covers on this product or attached devices.

To Disconnect:

1. Turn off everything (unless instructed otherwise).
2. Remove the power cords from the outlets.
3. Remove the signal cables from the connectors.
4. Remove all cables from the devices.

To Connect:

1. Turn off everything (unless instructed otherwise).
2. Attach all cables to the devices.
3. Attach the signal cables to the connectors.
4. Attach the power cords to the outlets.
5. Turn on the devices.

(D005)

## DANGER



Observe the following precautions when working on or around your IT rack system:

- Heavy equipment—personal injury or equipment damage might result if mishandled.
- Always lower the leveling pads on the rack cabinet.
- Always install stabilizer brackets on the rack cabinet.
- To avoid hazardous conditions due to uneven mechanical loading, always install the heaviest devices in the bottom of the rack cabinet. Always install servers and optional devices starting from the bottom of the rack cabinet.
- Rack-mounted devices are not to be used as shelves or work spaces. Do not place objects on top of rack-mounted devices.



- Each rack cabinet might have more than one power cord. Be sure to disconnect all power cords in the rack cabinet when directed to disconnect power during servicing.
- Connect all devices installed in a rack cabinet to power devices installed in the same rack cabinet. Do not plug a power cord from a device installed in one rack cabinet into a power device installed in a different rack cabinet.
- An electrical outlet that is not correctly wired could place hazardous voltage on the metal parts of the system or the devices that attach to the system. It is the responsibility of the customer to ensure that the outlet is correctly wired and grounded to prevent an electrical shock.

#### CAUTION

- Do not install a unit in a rack where the internal rack ambient temperatures will exceed the manufacturer's recommended ambient temperature for all your rack-mounted devices.
- Do not install a unit in a rack where the air flow is compromised. Ensure that air flow is not blocked or reduced on any side, front, or back of a unit used for air flow through the unit.
- Consideration should be given to the connection of the equipment to the supply circuit so that overloading of the circuits does not compromise the supply wiring or overcurrent protection. To provide the correct power connection to a rack, refer to the rating labels located on the equipment in the rack to determine the total power requirement of the supply circuit.
- *(For sliding drawers.)* Do not pull out or install any drawer or feature if the rack stabilizer brackets are not attached to the rack. Do not pull out more than one drawer at a time. The rack might become unstable if you pull out more than one drawer at a time.
- *(For fixed drawers.)* This drawer is a fixed drawer and must not be moved for servicing unless specified by the manufacturer. Attempting to move the drawer partially or completely out of the rack might cause the rack to become unstable or cause the drawer to fall out of the rack.

(R001)

**CAUTION:**

Removing components from the upper positions in the rack cabinet improves rack stability during relocation. Follow these general guidelines whenever you relocate a populated rack cabinet within a room or building:

- Reduce the weight of the rack cabinet by removing equipment starting at the top of the rack cabinet. When possible, restore the rack cabinet to the configuration of the rack cabinet as you received it. If this configuration is not known, you must observe the following precautions:
  - Remove all devices in the 32U position and above.
  - Ensure that the heaviest devices are installed in the bottom of the rack cabinet.
  - Ensure that there are no empty U-levels between devices installed in the rack cabinet below the 32U level.
- If the rack cabinet you are relocating is part of a suite of rack cabinets, detach the rack cabinet from the suite.
- Inspect the route that you plan to take to eliminate potential hazards.
- Verify that the route that you choose can support the weight of the loaded rack cabinet. Refer to the documentation that comes with your rack cabinet for the weight of a loaded rack cabinet.
- Verify that all door openings are at least 760 x 230 mm (30 x 80 in.).
- Ensure that all devices, shelves, drawers, doors, and cables are secure.
- Ensure that the four leveling pads are raised to their highest position.
- Ensure that there is no stabilizer bracket installed on the rack cabinet during movement.
- Do not use a ramp inclined at more than 10 degrees.
- When the rack cabinet is in the new location, complete the following steps:
  - Lower the four leveling pads.
  - Install stabilizer brackets on the rack cabinet.
  - If you removed any devices from the rack cabinet, repopulate the rack cabinet from the lowest position to the highest position.
- If a long-distance relocation is required, restore the rack cabinet to the configuration of the rack cabinet as you received it. Pack the rack cabinet in the original packaging material, or equivalent. Also lower the leveling pads to raise the casters off of the pallet and bolt the rack cabinet to the pallet.

(R002)

(L001)



(L002)



(L003)



or



All lasers are certified in the U.S. to conform to the requirements of DHHS 21 CFR Subchapter J for class 1 laser products. Outside the U.S., they are certified to be in compliance with IEC 60825 as a class 1 laser product. Consult the label on each part for laser certification numbers and approval information.

**CAUTION:**

This product might contain one or more of the following devices: CD-ROM drive, DVD-ROM drive, DVD-RAM drive, or laser module, which are Class 1 laser products. Note the following information:

- Do not remove the covers. Removing the covers of the laser product could result in exposure to hazardous laser radiation. There are no serviceable parts inside the device.
- Use of the controls or adjustments or performance of procedures other than those specified herein might result in hazardous radiation exposure.

(C026)

**CAUTION:**

Data processing environments can contain equipment transmitting on system links with laser modules that operate at greater than Class 1 power levels. For this reason, never look into the end of an optical fiber cable or open receptacle. (C027)

**CAUTION:**

This product contains a Class 1M laser. Do not view directly with optical instruments. (C028)

**CAUTION:**

Some laser products contain an embedded Class 3A or Class 3B laser diode. Note the following information: laser radiation when open. Do not stare into the beam, do not view directly with optical instruments, and avoid direct exposure to the beam. (C030)

**CAUTION:**

The battery contains lithium. To avoid possible explosion, do not burn or charge the battery.

*Do Not:*

- \_\_\_ Throw or immerse into water
- \_\_\_ Heat to more than 100°C (212°F)
- \_\_\_ Repair or disassemble

Exchange only with the IBM-approved part. Recycle or discard the battery as instructed by local regulations. In the United States, IBM has a process for the collection of this battery. For information, call 1-800-426-4333. Have the IBM part number for the battery unit available when you call. (C003)

## **Power and cabling information for NEBS (Network Equipment-Building System) GR-1089-CORE**

The following comments apply to the IBM servers that have been designated as conforming to NEBS (Network Equipment-Building System) GR-1089-CORE:

The equipment is suitable for installation in the following:

- Network telecommunications facilities
- Locations where the NEC (National Electrical Code) applies

The intrabuilding ports of this equipment are suitable for connection to intrabuilding or unexposed wiring or cabling only. The intrabuilding ports of this equipment *must not* be metallically connected to the interfaces that connect to the OSP (outside plant) or its wiring. These interfaces are designed for use as intrabuilding interfaces only (Type 2 or Type 4 ports as described in GR-1089-CORE) and require isolation from the exposed OSP cabling. The addition of primary protectors is not sufficient protection to connect these interfaces metallically to OSP wiring.

**Note:** All Ethernet cables must be shielded and grounded at both ends.

The ac-powered system does not require the use of an external surge protection device (SPD).

The dc-powered system employs an isolated DC return (DC-I) design. The DC battery return terminal *shall not* be connected to the chassis or frame ground.

## Installing the EDR1 PCIe storage enclosure

Use this overview as a guide to the tasks required for installing the EDR1 PCI Express (PCIe) storage enclosure (EXP30 Ultra SSD I/O Drawer) into a rack and cabling it to a server.

You will need to refer to the following topics while installing the EDR1 PCIe storage enclosure:

- Installing the rack (<http://publib.boulder.ibm.com/infocenter/systems/scope/hw/topic/p7hbf/installrack.htm>)
- EDR1 PCIe storage enclosures ([http://publib.boulder.ibm.com/infocenter/systems/scope/hw/topic/p7ham/p7ham\\_edr1\\_kickoff.htm](http://publib.boulder.ibm.com/infocenter/systems/scope/hw/topic/p7ham/p7ham_edr1_kickoff.htm))
- Removing, installing, or replacing a solid-state drive for an EDR1 PCIe storage enclosure (<http://publib.boulder.ibm.com/infocenter/systems/scope/hw/topic/p7eeq/p7eeqdiskunit.htm>)

You can use the following table to read about and complete the high-level tasks for installing the EDR1 PCIe storage enclosure.

*Table 1. Tasks to install the PCIe storage enclosure into a rack*

Task	Where to find associated information
<p><b>Preinstalled enclosures only</b></p> <p>Remove the front and rear shipping brackets.</p> <p>After you have removed the shipping brackets, review the configuration options for adding the PCIe storage enclosure to the server. See step 10 on page 15.</p>	<p>To remove the front and rear shipping brackets, see step 2 on page 3.</p>
<p>Perform inventory.</p> <p>Ensure that you have the rails.</p> <p>Ensure that you have both a Philips-head and flat-head screwdriver.</p>	<p>Locate the inventory list for your PCIe storage enclosure, and verify that you received all of the parts that you ordered.</p> <p>Each order contains, at a minimum, the following items:</p> <ul style="list-style-type: none"> <li>• Left and right rack-mounting rails</li> <li>• Mounting screws</li> <li>• Alignment screws</li> <li>• Cable bracket screws</li> <li>• Power supply cables</li> </ul> <p>If your shipment contains parts that are not required to complete the installation procedure, store those parts until they are to be used.</p> <p>If you have incorrect, missing, or damaged parts, consult any of the following resources:</p> <ul style="list-style-type: none"> <li>• Your IBM reseller.</li> <li>• IBM Rochester manufacturing automated information at 1-800-300-8751 (United States only).</li> <li>• Directory of worldwide contacts website at <a href="http://www.ibm.com/planetwide">http://www.ibm.com/planetwide</a>. Select your location to view the service and support contact information.</li> </ul> <p>You can also obtain order information from your sales representative or IBM Business Partner.</p>

Table 1. Tasks to install the PCIe storage enclosure into a rack (continued)

Task	Where to find associated information
Verify that you have a rack and that it is properly adjusted for the correct size.	You must have a rack that is installed. If you do not have a rack that is installed, see <i>Installing the rack</i> ( <a href="http://publib.boulder.ibm.com/infocenter/systems/scope/hw/topic/p7hbf/installrack.htm">http://publib.boulder.ibm.com/infocenter/systems/scope/hw/topic/p7hbf/installrack.htm</a> ).
Determine where to install the PCIe storage enclosure in the rack.	For suggestions about how to organize the hardware in your rack and to assign a location for the PCIe storage enclosure, see step 5 on page 8.
Mark the location on the rack where the PCIe storage enclosure will be installed.	To mark the rack location where you will install the PCIe storage enclosure, see step 7 on page 8.
Install the rail assembly in the rack.	To install the mounting hardware in the rack, see step 8 on page 8.
Install the PCIe storage enclosure on the rail assembly. <b>Note:</b> If you have solid-state drive (SSD) units that require installation to the PCIe storage enclosure, install them before you install the EMC covers.	To install the PCIe storage enclosure on the rail assembly, see step 9 on page 11.
Review the configuration options for adding the PCIe storage enclosure to the server.	To identify the configuration option that you will use from a list of example configurations, see step 10 on page 15.
Add the PCIe storage enclosure to the server and verify that the configuration is functional.	Add the expansion unit to the system by completing the following steps: <ol style="list-style-type: none"><li>1. Read important information about expansion units at <i>Overview for PCIe storage enclosures</i> (<a href="http://publib.boulder.ibm.com/infocenter/systems/scope/hw/topic/p7ham/p7ham_pcistor_concepts.htm">http://publib.boulder.ibm.com/infocenter/systems/scope/hw/topic/p7ham/p7ham_pcistor_concepts.htm</a>).</li><li>2. Complete the procedure for adding the expansion unit at <i>Adding PCIe storage enclosures</i> (<a href="http://publib.boulder.ibm.com/infocenter/systems/scope/hw/topic/p7ham/p7ham_pcistor_connkick_edr1.htm">http://publib.boulder.ibm.com/infocenter/systems/scope/hw/topic/p7ham/p7ham_pcistor_connkick_edr1.htm</a>).</li></ol>
Configure the solid-state drives of the PCIe storage enclosure.	To review serial-attached SCSI (SAS) Redundant Array of Independent Disks (RAID) information and configure the enclosure to the specifications of your operating system and system configuration, see step 15 on page 18.

---

## Installing the EDR1 PCIe storage enclosure: Details

The detailed installation procedure includes information from online references that are specified in the overview. You can use the expanded instructions in this procedure to install your PCIe storage enclosure into a rack and to cable it to a server.

- This information is provided in printed form as a list of basic tasks for installing the EDR1 PCIe storage enclosure. For the most current version, use the online information: Installing the EDR1 PCIe storage enclosure (<http://publib.boulder.ibm.com/infocenter/systems/scope/hw/topic/p7eep/p7eep.pdf>).
- This procedure supports the following installation scenarios:
  - Your EDR1 PCIe storage enclosure was delivered already mounted in a rack, and you need to complete the installation.
  - Your EDR1 PCIe storage enclosure was delivered separately from a rack, and you need to mount the enclosure in an existing rack and complete the installation.

**Note:** If the rack is not yet installed, you must first complete the procedure for Installing the rack (<http://publib.boulder.ibm.com/infocenter/systems/scope/hw/topic/p7hbf/installrack.htm>).

- Before you install the PCIe storage enclosure into a rack, read the Rack safety notices (<http://publib.boulder.ibm.com/infocenter/systems/scope/hw/topic/p7hbf/racksafety.htm>).

To install the EDR1 PCIe storage enclosure, complete the following tasks:

1. Choose the type of installation you are performing:
  - To complete the installation of a EDR1 PCIe storage enclosure that was delivered already mounted in a rack, go to step 2.
  - To complete the installation of a EDR1 PCIe storage enclosure that was delivered separately from a rack, go to step 4 on page 8.
2. Remove the shipping bracket that is attached at the rear of the PCIe storage enclosure as follows:

**Note:** You need a medium size screwdriver to complete this task.

- a. At the rear of the rack, find the rear panel of the EDR1 PCIe storage enclosure. Observe that the enclosure contains a power supply on each side of the unit behind the shipping bracket. Each power supply handle (**A**) is attached to a tab (**B**) of the rear shipping bracket (**C**) by using an orange releasable Panduit tie wrap (**D**), as shown in the following figure.

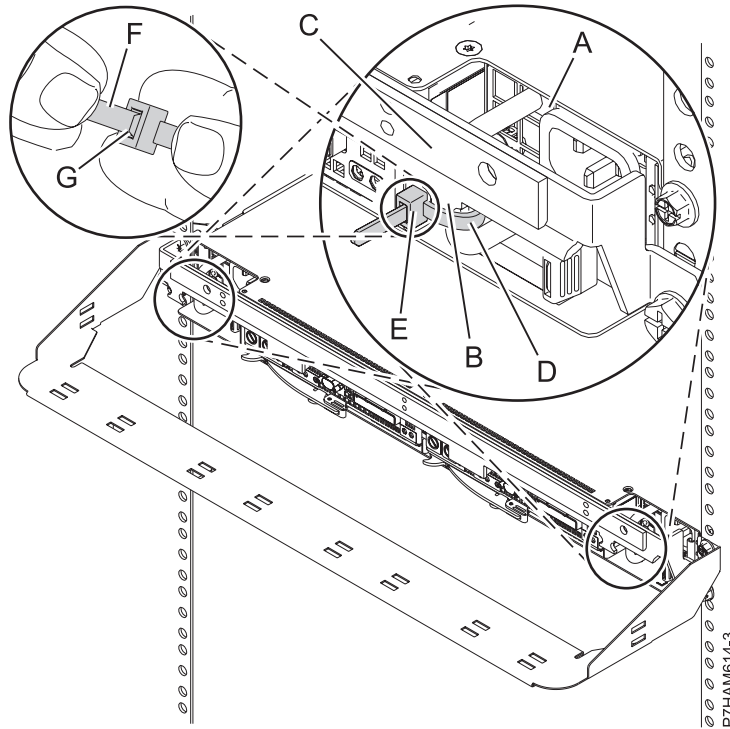
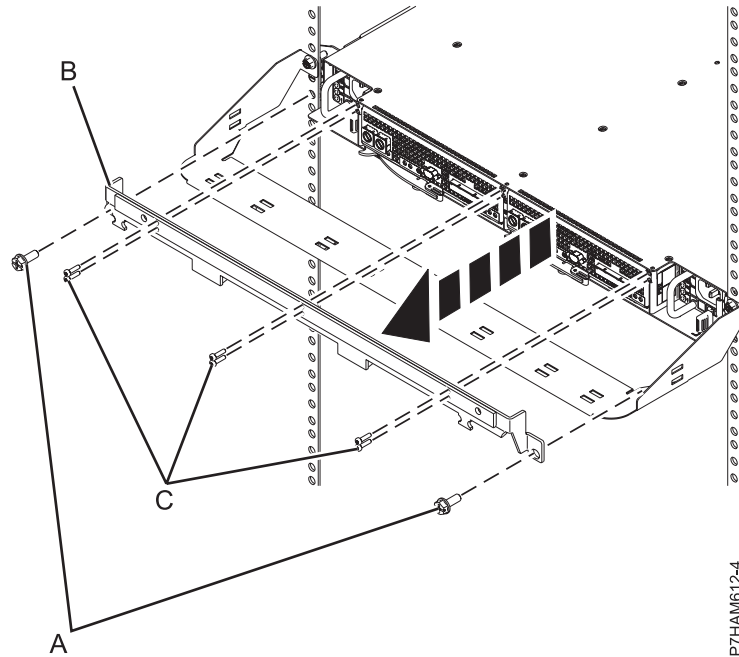

Figure 1. Power supply attachment to the rear shipping bracket

- b. To remove a Panduit tie wrap (D), use one hand to hold the tie wrap head (E) between two fingers, and use your other hand to hold the loose end (F) of the tie wrap, as shown in the preceding figure. Then, while you use your thumb nail to catch and pull the release (G) in the tie wrap head, push the loose end through the head to expand the tie wrap loop. When the loose end is fed completely through, remove the tie wrap. Then, remove the other Panduit tie wrap.
- c. Using a screwdriver, remove the two screws (A) that attach the rear shipping bracket (B) to the left and right flanges of the rack frame, as shown in the following figure. Use the screwdriver that is provided in the installation kit to remove the six screws (C) that attach the rear shipping bracket (B) to the rear of the PCIe storage enclosure. Lift the bracket away from the rack frame.

**Tip:** Save all of the brackets and screws that you have removed for any future reinstallation and for shipping of the EDR1 PCIe storage enclosure that might be required.





P7HAM612-4

Figure 2. Removing the rear shipping bracket

- d. Dock one of the power supplies by gently sliding it into the enclosure until the orange release tab latches, as shown in the following figure. Then, dock the other power supply.

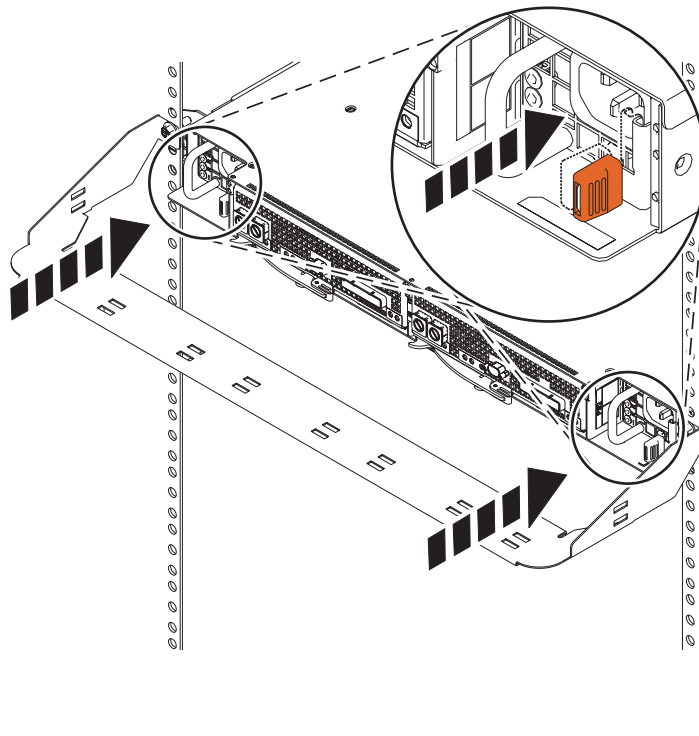

P7HAM615-1

Figure 3. Docking the power supply

- e. At the front of the rack, find the front panel of the EDR1 PCIe storage enclosure. Hold the service card (A) with its handle away from the enclosure and facing upward, as shown in the following

figure. Align the other end of the service card with the bottom of the last bank of solid-state drives (SSDs) on the right of the enclosure (**B**). Gently slide the service card into the space between the bottom SSD slot and the sheet metal of the chassis (**C**).

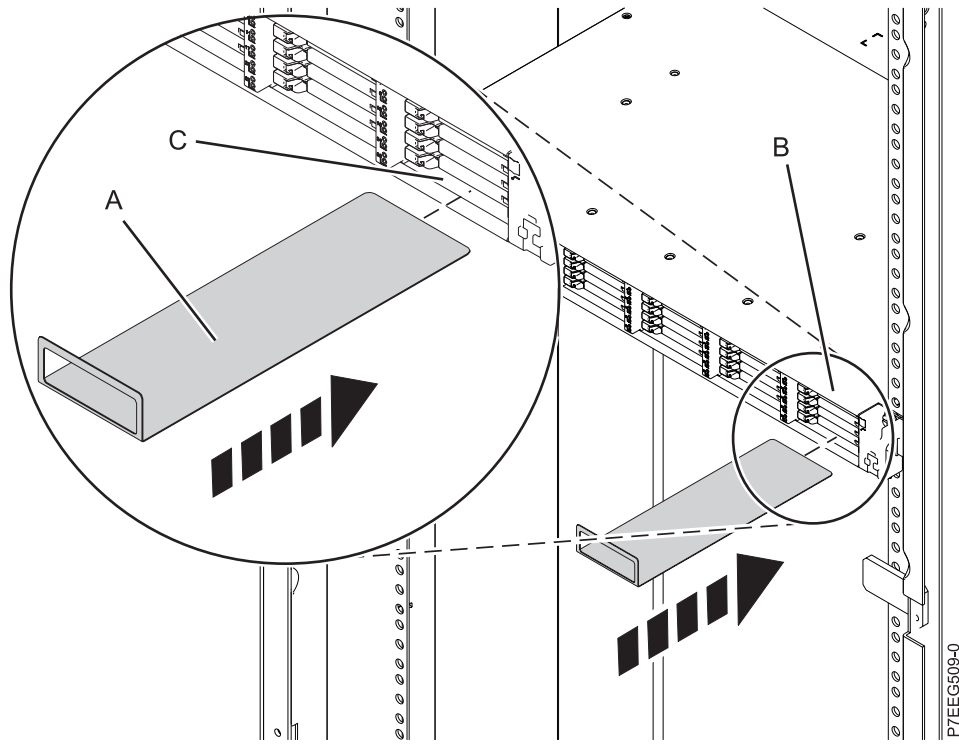

Figure 4. Inserting the service card

- f. Install the six SSD EMC bezels (**A**) to cover the slots that contain the SSDs, as shown in the following figure.

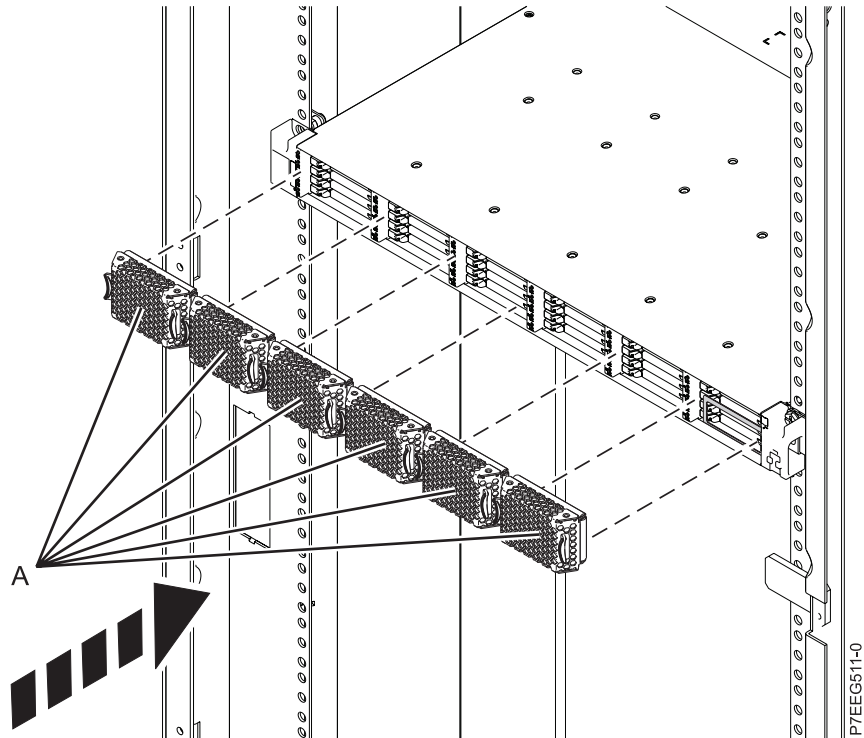

Figure 5. Installing the SSD EMC bezels

- g. At the rear of the rack, install the power cables (A), as shown in the following figure. Use hook-and-loop fastener ties to secure the power cords to the cable management bracket.

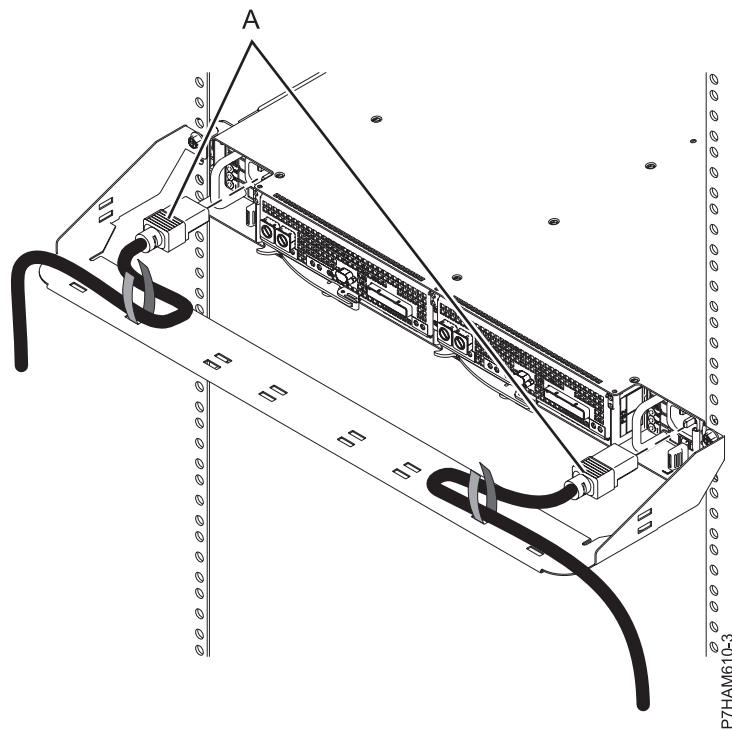

Figure 6. Installing the power cords

**Important:** Do not connect the power cords to the power source until you are directed to do so.

3. Go to step 10 on page 15 to identify the configuration and cable requirements for adding the PCIe storage enclosure to the system.
4. Unpack the PCIe storage enclosure as follows:
  - a. Refer to the kitting list provided with the rack installation kit, and complete a parts inventory.
  - b. Locate the rack-mounting hardware kit and the system rail assemblies that were included with your PCIe storage enclosure.

The rails are front-to-back and left-to-right side dependent.

5. Determine where to install the PCIe storage enclosure into the rack as follows:
  - a. Organize larger and heavier units into the lower part of the rack.
  - b. Plan to install units into the lower part of the rack first.
  - c. Record the EIA locations in your plan.

**Note:** The PCIe storage enclosure is one Electronic Industries Alliance (EIA) unit high. An EIA unit is 44.50 mm (1.75 in.) in height. The rack contains three mounting holes for each EIA unit of height. This enclosure, therefore, is 44.50 mm (1.75 in.) high and covers 3 mounting holes in the rack.

6. If necessary, remove the front and rear rack doors.
7. Mark the rack location where you will install the PCIe storage enclosure by completing the following steps:

**Note:** The PCIe cable length must be considered for the correct placement of the enclosure relative to the location of the system. Systems might require a significant amount of cabling through the cable management arms, if present.

- a. Face the front of the rack and work from the left side. Make a note of the EIA unit to be used for the PCIe storage enclosure. Use tape, a marker, or a pencil to mark the middle mounting hole (**A**) of the EIA unit. Place another mark beside the bottom mounting hole (**B**). Mark the rack so that these marks can also be seen from the rear of the rack.

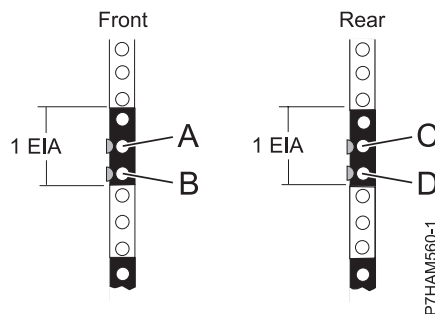

Figure 7. Marking the installation locations

- b. Repeat the last step to place two marks on the corresponding mounting holes on the front-right side of the rack.
- c. Go to the rear of the rack. On the left side, find the EIA unit to be used for the PCIe storage enclosure.
- d. Mark the middle mounting hole (**C**) of this EIA unit. Place another mark beside the bottom mounting hole (**D**).
- e. Repeat the last step to place two marks on the corresponding mounting holes on the rear-right side of the rack.
8. Install the rail assembly into the rack as follows:

**Important:** The rail installation can be completed by one person. However, the installation is easier if one person is positioned at the front of the rack and one person is positioned at the rear of the

rack. You will also need two people later in this procedure to install the enclosure into the rack.

**CAUTION:**

**Installing the rails in the rack is a complex procedure. To install the rails correctly, you must complete each task in the following order. Failure to do so might cause rail failure and potential danger to yourself and the system unit.**

- a. Facing the front of the rack, locate the two marks that were made previously on the Electronic Industries Alliances (EIA) strips.

**Note:** To install the rails in the limited rack space for this enclosure model, ensure that you have open workspace either directly above or directly below the EIA location that you have marked. If the rack spaces directly above and below the EIA location currently contain hardware, choose one of the following options to increase the workspace:

- If the hardware unit directly above or below the EIA location can be slid into a service position, do so now to provide more workspace.
  - Remove the hardware unit either directly above or below the EIA location to provide more workspace, and reinstall it following the rails installation.
- b. Select a rail. Identify the side of the rack where the rail must be mounted by holding the rail inside of the open space of the rack as follows:
    - The rail points from front to rear.
    - The tension clip (A) points toward the front of the rack and aligns with the bottom EIA hole that you marked previously, as shown in Figure 8.
    - The rail shaft is aligned with the inside edge of the front rack flange with its open side facing inward.
  - c. Push up the tension clip (A) and insert it into the bottom EIA hole that you marked previously, as shown in Figure 8. Ensure that the lip of the clip is brought fully through the hole and clasped against the bottom of the hole. Seat the alignment screw (B) in the middle EIA hole that you marked previously.

**Note:** There are two sizes of alignment screws (B). If your rack has round mounting holes, use the smaller alignment screw for each rail. If your rack has square mounting holes, use the larger alignment screw for each rail. Alignment screws are provided with the rack installation kit.

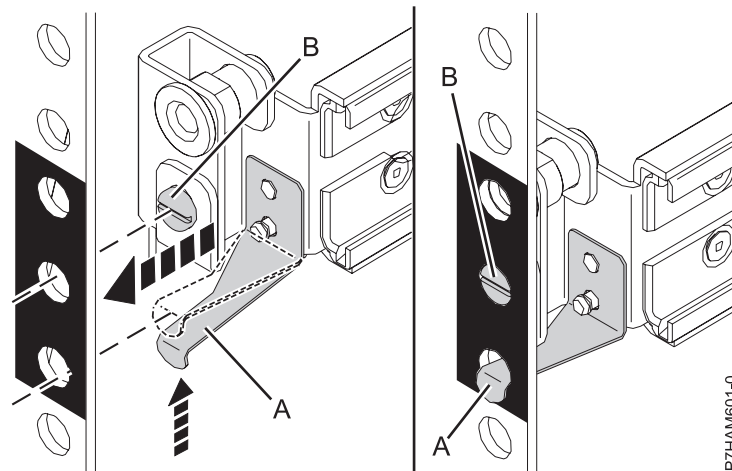

Figure 8. Mounting the rail to the front of the rack

- d. At the rear of the rack, locate the two marks that you made previously on the EIA strips. Compress the rail (C) as shown in Figure 9 on page 10, and then expand the rail carefully toward the marks until the rail end meets the rear rack flange.

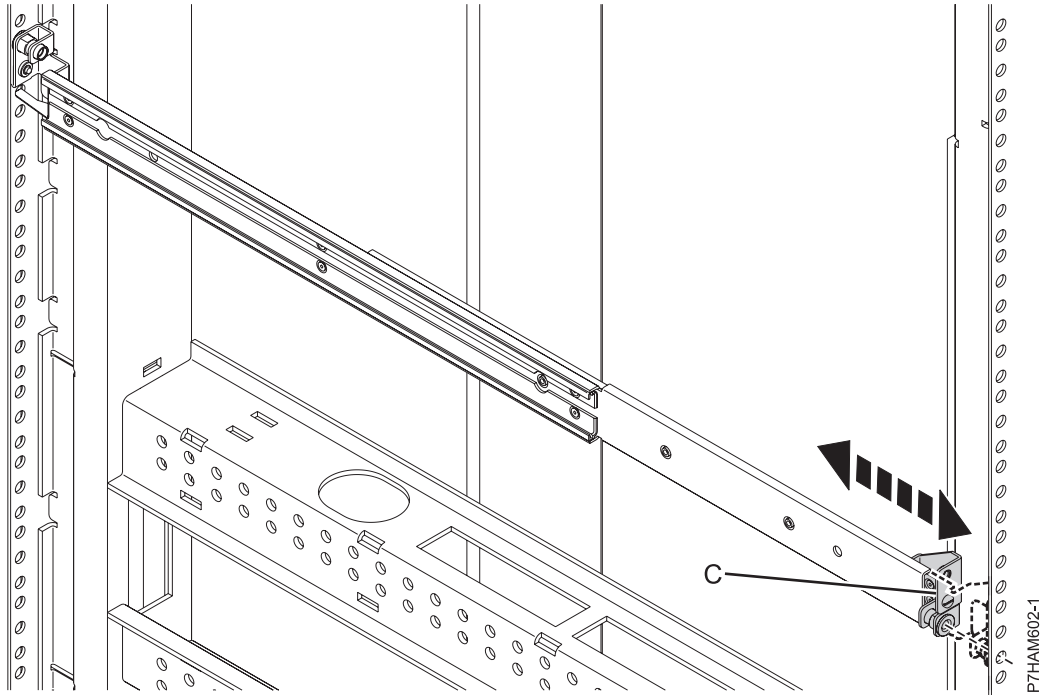

Figure 9. Expanding the rail to the rear of the rack

- e. Seat the alignment screw **(D)** of the rail into the middle EIA hole that you marked previously, as shown in Figure 10.

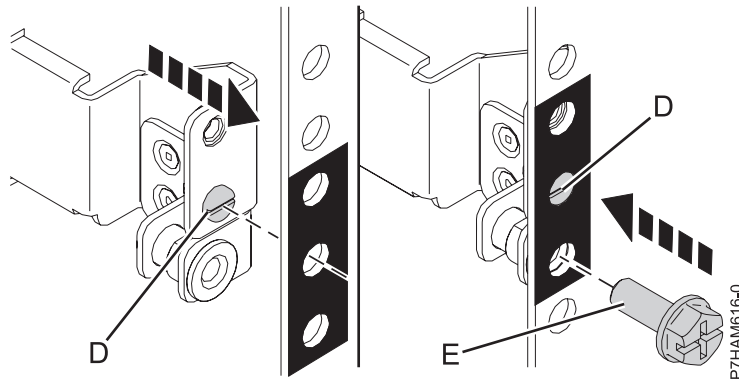

Figure 10. Mounting the rail to the rear of the rack

- f. Insert a mounting screw **(E)** through the bottom EIA hole, attaching the rail to the rear of the rack as shown in Figure 10.
- g. Repeat step 8c on page 9 through step 8f for the other rail.
- h. At the rear of the rack, hold the cable management bracket up to the rear rack flanges, aligning the mounting holes on the bracket to the top holes of the EIA that contains the enclosure, as shown in Figure 11 on page 11. Apply the M5 screws **(E)** through the mounting holes of the bracket and into the top EIA holes on the rack flanges.

**CAUTION:** To provide for the secure attachment of the rails, the M5 screws **(E)** must be applied at the specified EIA locations even if you do not mount the cable management bracket.

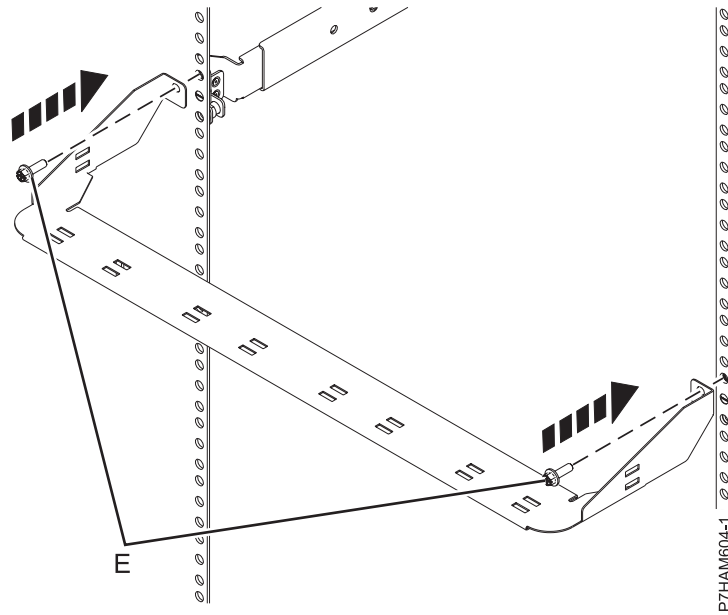

Figure 11. Mounting the cable management bracket

9. Install the PCIe storage enclosure onto the rails as follows:
  - a. Before you attempt to mount the PCIe storage enclosure to the rails, review Figure 12 to observe how the chassis bracket guide (A) on the side of the enclosure fits and slides into the rail sheath (B) that matches its shape.

**Note:** In Figure 12, the right rail (B) is portrayed at an angle to show the location of the rail sheath. The actual rail is mounted in an upright position in the rack.

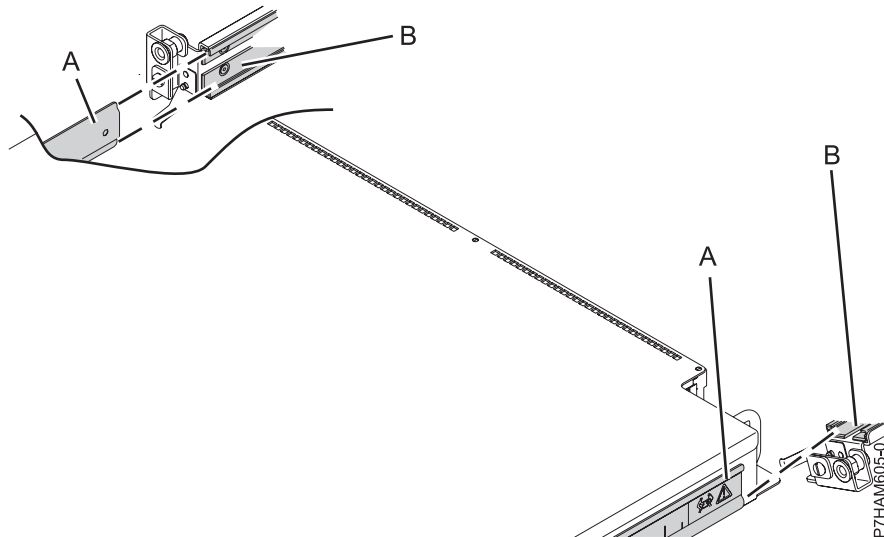

Figure 12. Reviewing the enclosure attachment to the rails

**Attention:** Because of the precision that is required to align and connect these parts, you must use two people to move the enclosure. Using fewer than two people can result in damage to the enclosure.

- b. Position one person on each side of the PCIe storage enclosure and lift the enclosure. At the front of the rack, position the rear of the enclosure in front of the rails.

- c. Simultaneously, insert both of the chassis bracket guides (A) into the rail sheath (B) opening, as shown in Figure 13.

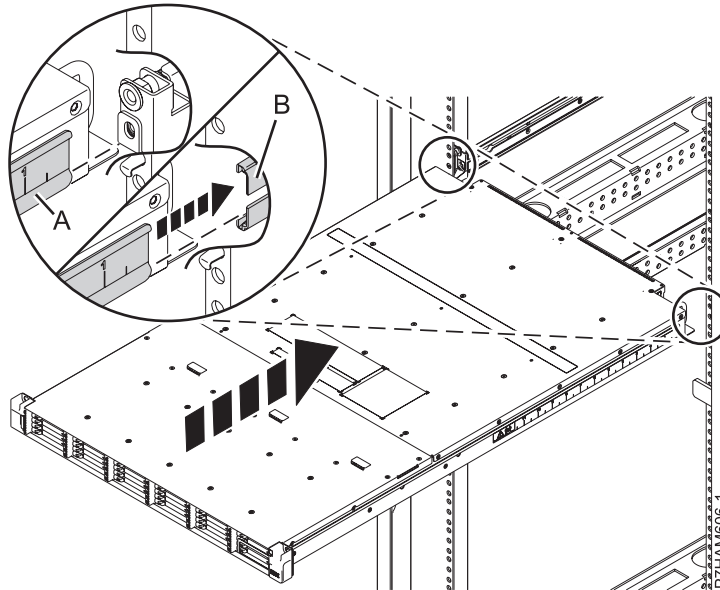

Figure 13. Fitting the enclosure into the rail sheath

- d. When the chassis bracket guides are firmly seated on both sides of the enclosure, slide the enclosure gently into the rack cabinet, as shown in Figure 14.

**CAUTION:**

Ensure that no one's fingers are located between the enclosure and the cable management bracket when you slide the enclosure into the rack cabinet.

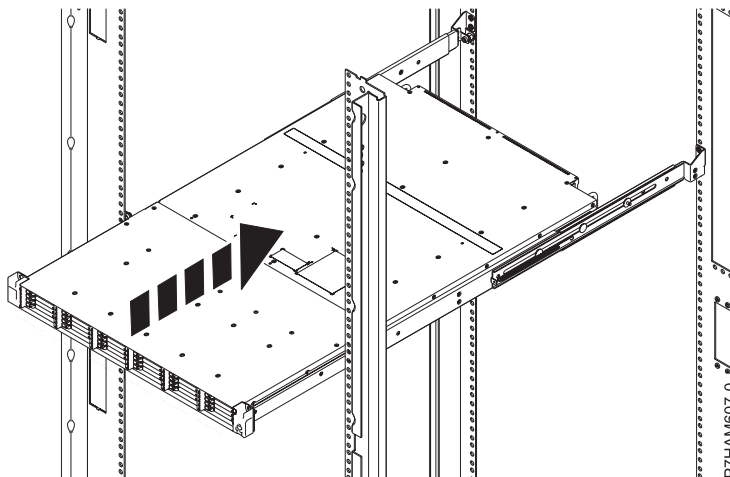

Figure 14. Sliding the disk drive enclosure into the rack

- e. Secure the front of the enclosure to the rack flanges by applying the securing screws (A) through the top open holes in each bracket and into the top EIA holes, as shown in Figure 15 on page 13.



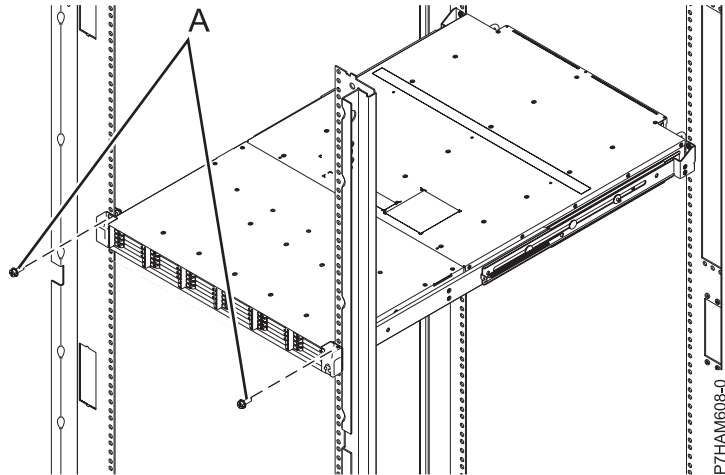

Figure 15. Securing the front of the enclosure to the rack

- f. At the front panel of the enclosure, hold the service card (A) with its handle away from the enclosure and facing upward, as shown in Figure 16. Align the other end of the service card with the bottom of the last bank of solid-state drives (SSDs) on the right of the enclosure (B). Gently slide the service card into the space between the bottom SSD slot and the sheet metal of the chassis (C).

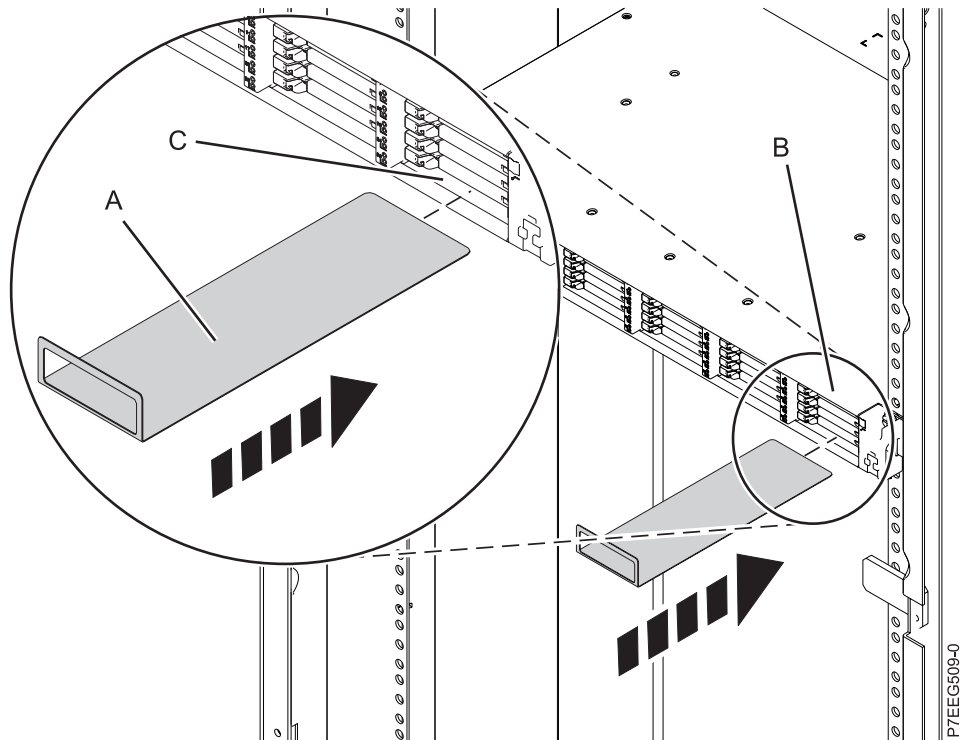

Figure 16. Inserting the service card

- g. If you have SSDs that require installation to the PCIe storage enclosure, install the SSDs before you install the EMC covers. For instructions, see Removing and installing a solid-state drive for an EDR1 PCIe storage enclosure (<http://publib.boulder.ibm.com/infocenter/systems/scope/hw/topic/p7eeq/p7eeqdiskunit.htm>) and select the topic that supports the server to which you are installing this PCIe storage enclosure.

- h. Install the six SSD EMC bezels (A) to cover the slots that contain the SSDs, as shown in Figure 17.

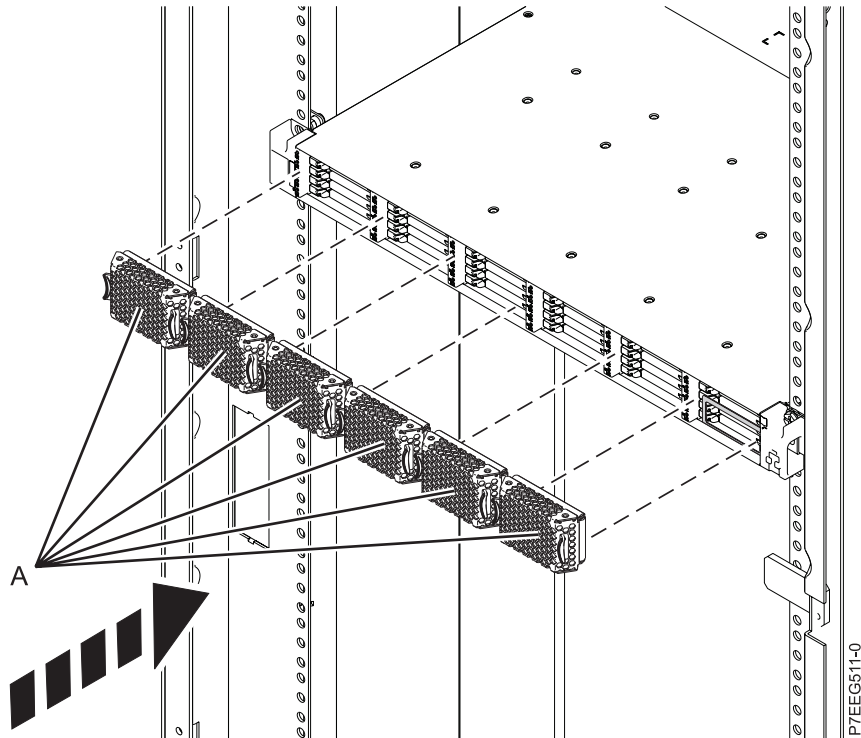

Figure 17. Installing the SSD EMC bezels

- i. At the rear of the rack, install the power cables (A), as shown in Figure 18 on page 15.

**Important:** Do not connect the power cords to the power source until you are directed to do so.

- j. Use hook-and-loop fastener ties to secure the power cords to the cable management bracket.

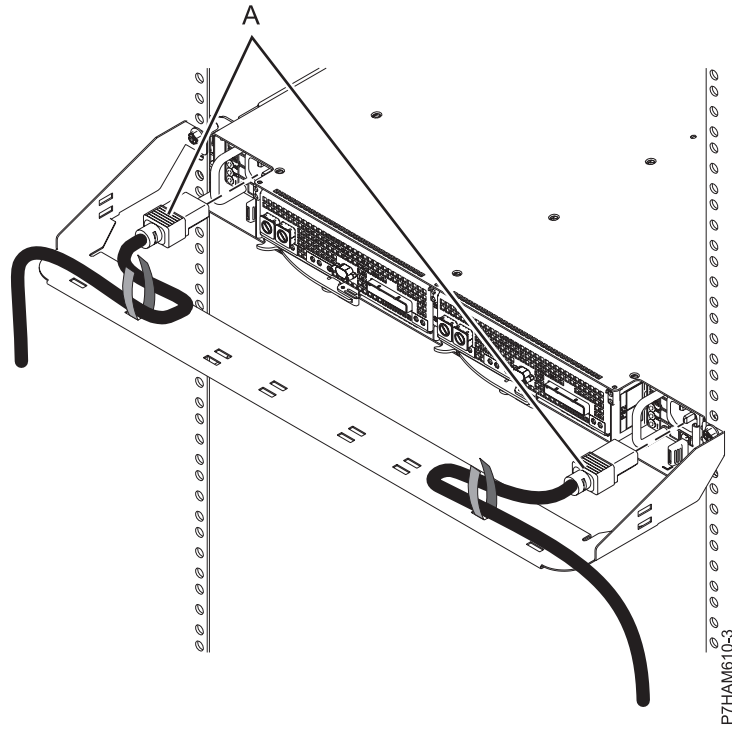

Figure 18. Installing the power cords

10. Identify the configuration and cable requirements for adding the PCIe storage enclosure to the system.

**Note:** For detailed examples of configuration and cable requirements for your specific server, see “Cabling the PCIe storage enclosure” on page 27.

- a. Connect a server that has one PCIe GX++ adapter to a single storage enclosure, as shown in the following figure.

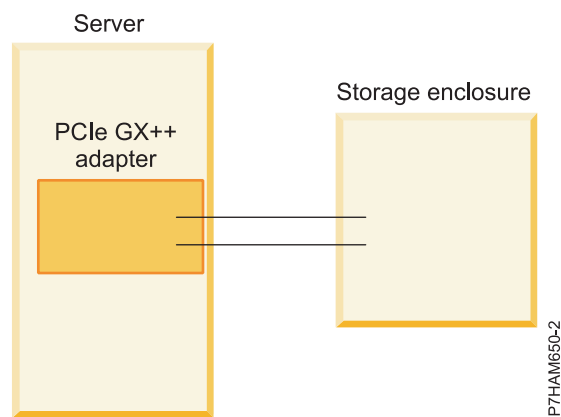

Figure 19. Example of a server that has one PCIe GX++ adapter connected to a single storage enclosure

- b. Connect a server that has two PCIe GX++ adapters to two storage enclosures, as shown in the following figure.

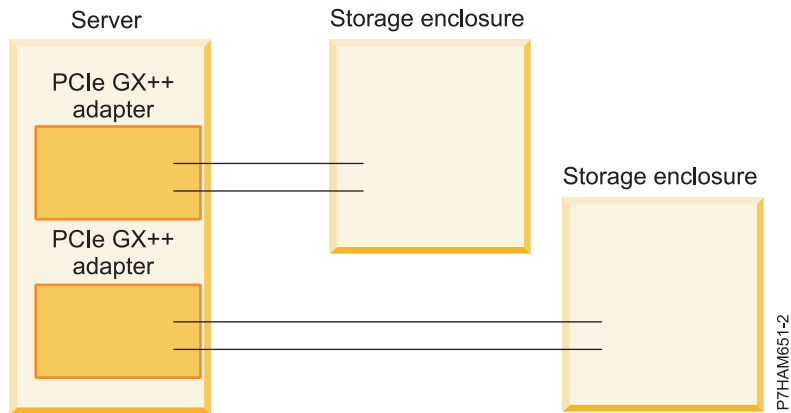

Figure 20. Example of a server that has two PCIe GX++ adapters connected to two storage enclosures

- c. Connect a server that has two PCIe GX++ adapters to a single storage enclosure, as shown in the following figure.

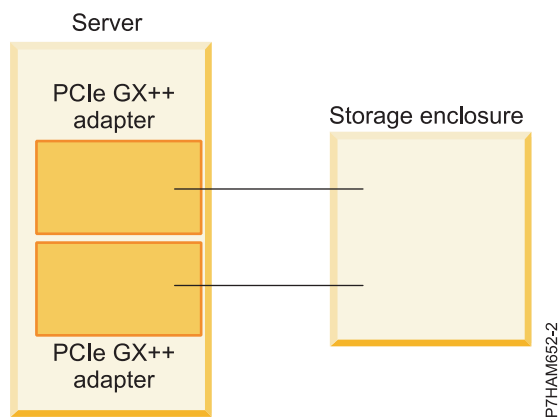

Figure 21. Example of a server that has two PCIe GX++ adapters connected to a single storage enclosure

- d. Connect a server that has two PCIe GX++ adapters to two storage enclosures for high availability, as shown in the following figure.

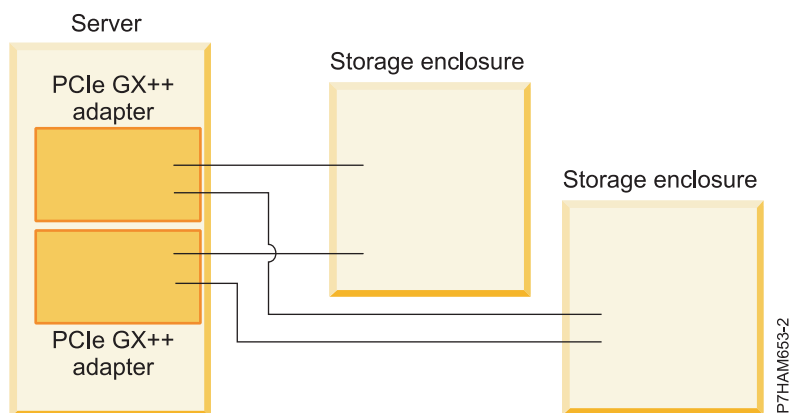

Figure 22. Example of a server that has two PCIe GX++ adapters connected to two storage enclosures for high availability

- e. Connect two servers, each with a PCIe GX++ adapter, to a single storage enclosure for high availability, as shown in the following figure.

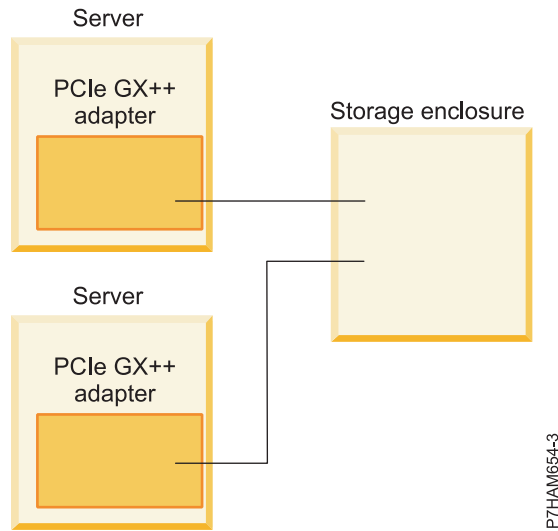

Figure 23. Example of two servers, each with a PCIe GX++ adapter, connected to a single storage enclosure for high availability

- f. Connect two processor drawers, each with a PCIe GX++ adapter, to a single storage enclosure for high availability, as shown in the following figure.

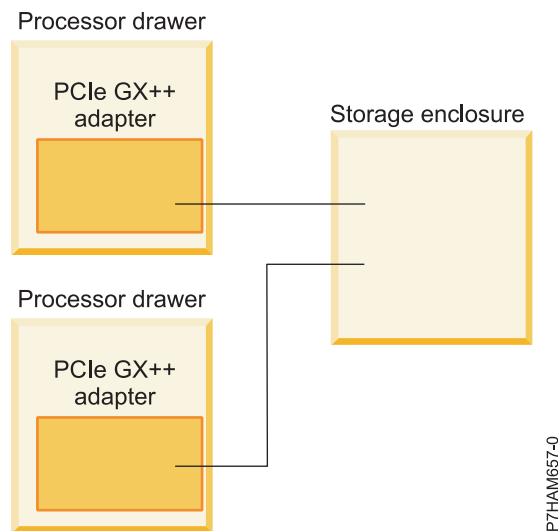

Figure 24. Example of two processor drawers, each with a PCIe GX++ adapter, connected to a single storage enclosure for high availability

11. Use hook-and-loop fastener ties to secure the PCIe and SAS cables to the cable management bracket.
12. You have now completed the steps to install the EDR1 PCIe storage enclosure into a rack. Continue with step 13 to learn how to add the enclosure to the system.
13. Add the enclosure to the system by completing the following steps:
  - a. Read important information about enclosure at Overview for PCIe storage enclosures ([http://publib.boulder.ibm.com/infocenter/systems/scope/hw/topic/p7ham/p7ham\\_pcistor\\_concepts.htm](http://publib.boulder.ibm.com/infocenter/systems/scope/hw/topic/p7ham/p7ham_pcistor_concepts.htm)).

- b. Complete the procedure for adding the enclosure at Adding PCIe storage enclosures ([http://publib.boulder.ibm.com/infocenter/systems/scope/hw/topic/p7ham/p7ham\\_pcistor\\_connkick\\_edr1.htm](http://publib.boulder.ibm.com/infocenter/systems/scope/hw/topic/p7ham/p7ham_pcistor_connkick_edr1.htm)).
14. If the power cords for the PCIe storage enclosure are not connected to the power source, connect them now. Then, power on the system. For details, see Starting the system or logical partition (<http://publib.boulder.ibm.com/infocenter/systems/scope/hw/topic/p7haj/crstartsys.htm>).
15. Configure the SSDs in the PCIe storage enclosure as required for your operating system and system configuration.
  - a. Review the following information:

The EDR1 PCIe storage enclosure can hold up to 30 solid-state drives (SSDs). The SSDs are physically organized in a single device partition within the enclosure. The devices cannot be split into separate physical groups.

As shown in the following figure, the EDR1 PCIe storage enclosure (A) supports the attachment of up to two optional 5887 disk drive enclosures (B) by using EX cables (C) for increased storage capacity.

**Note:** The AIX® and Linux operating systems support the attachment of up to two 5887 disk drive enclosures. The IBM i operating system supports the attachment of one 5887 disk drive enclosure.

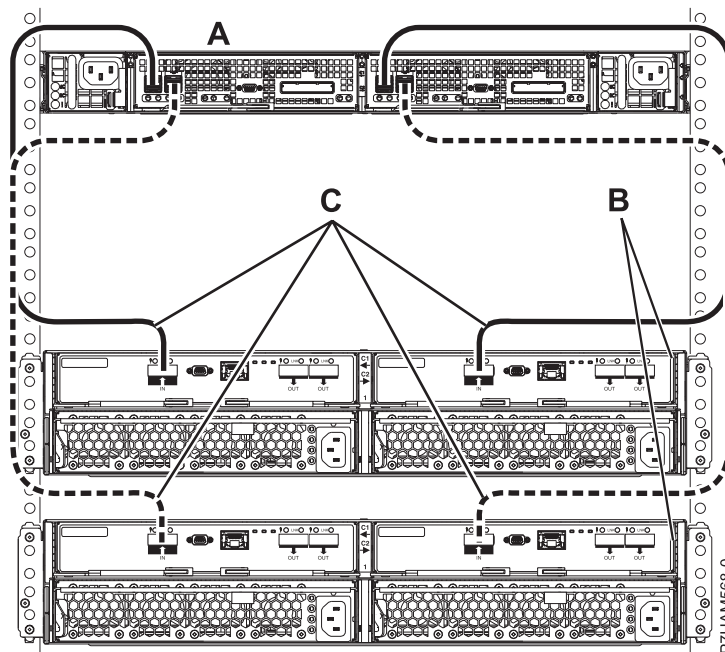

Figure 25. Connection of two 5887 disk drive enclosures by using EX cables to a PCIe storage enclosure

For detailed information about cabling a 5887 disk drive enclosure to the EDR1 PCIe storage enclosure, see Serial-attached SCSI cable planning (<http://publib.boulder.ibm.com/infocenter/systems/scope/hw/topic/p7had/p7hadsascabbling.htm>).

The 5887 disk drive enclosures must contain only hard disk drives (HDDs) and be factory-set to mode 1. The internal SSDs and any HDDs from attached 5887 disk drive enclosures are controlled by the dual PCIe2 SAS RAID controllers contained within the PCIe storage enclosure. SSDs and HDDs cannot be mixed in the same RAID array.

The EDR1 PCIe storage enclosure is supported by the following operating systems:

- AIX
- IBM i

- Linux
- VIOS

**Note:** VIOS does not support the EDR1 PCIe storage enclosure for an IBM i client.

To determine the level of software that you need to support the PCIe storage enclosure feature, see IBM Prerequisite ([http://www-912.ibm.com/e\\_dir/eServerPrereq.nsf](http://www-912.ibm.com/e_dir/eServerPrereq.nsf)).

**Tip:** If you are planning to configure RAID arrays, ensure that you have the minimum number of available disks for each RAID level:

**RAID 0**

Minimum of one drive per array

**RAID 5**

Minimum of three drives per array

**RAID 6**

Minimum of four drives per array

**RAID 10**

Minimum of two drives per array

Best performance is achieved when the access characteristics on each disk array have a balanced workload. This happens when the two controllers have an equal number of disk arrays with active paths to the disk units.

For additional SAS RAID controller information for the AIX operating system, see SAS RAID controller for AIX (<http://publib.boulder.ibm.com/infocenter/systems/scope/hw/topic/p7ebj/p7ebjkickoff.htm>).

For additional SAS RAID controller information for the IBM i operating system, see SAS RAID controllers for IBM i (<http://publib.boulder.ibm.com/infocenter/systems/scope/hw/topic/p7ed5/p7ed5kickoff.htm>).

For additional SAS RAID controller information for the Linux operating system, see SAS RAID controller for Linux (<http://publib.boulder.ibm.com/infocenter/systems/scope/hw/topic/p7ebk/p7ebkkickoff.htm>).





---

## Reference information

Use the information in this section as needed to complete enclosure installation and configuration tasks.

---

### Connector locations

Learn about 12X, system power control network (SPCN), and PCIe connector locations.

### Server connectors

Learn about connector locations for servers.

#### Model 8202-E4D connector locations

Learn about connector locations on rack-mounted models.

The 8202-E4D server provides cable connector locations for the following enclosures:

- Support for expansion units, as shown in the following figure, is as follows:
  - The card installed in the C1 slot can contain two 12X double data rate (DDR) cable ports. However, the C1 slot cannot provide both 12X DDR and PCIe cable ports.
  - The server contains a serial-attached SCSI (SAS) port.
- Support for disk drive enclosures, as shown in the following figure, is as follows:
  - The server contains a SAS port.
- Support for PCIe storage enclosures, as shown in the following figure, is as follows:
  - The card installed in the C1 slot can contain two PCIe cable ports. However, the C1 slot cannot provide both PCIe and 12X DDR cable ports.
  - The server contains a SAS port.

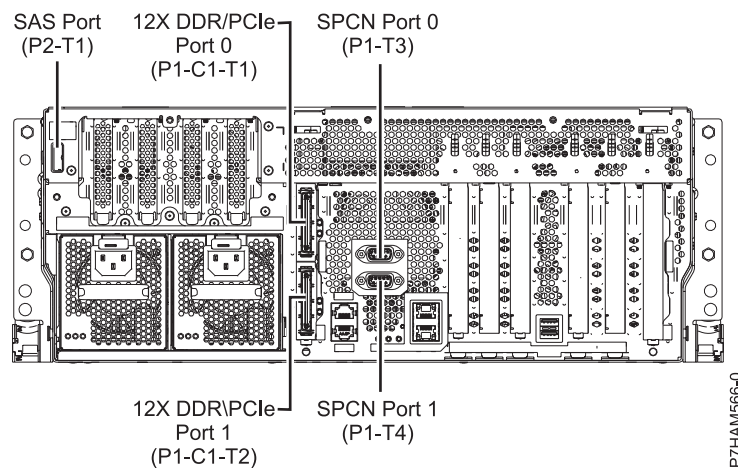

Figure 26. Model 8202-E4D connections for expansion units, disk drive enclosures, and PCIe storage enclosures

#### Model 8205-E6D connector locations

Learn about connector locations on rack-mounted models.

The 8205-E6D server provides cable connector locations for the following enclosures:

- Support for expansion units, as shown in the following figure, is as follows:

- The card installed in the C1 slot can contain two 12X double data rate (DDR) cable ports. However, the C1 slot cannot provide both 12X DDR and PCIe cable ports.
- The card installed in the C8 slot can contain two 12X DDR cable ports. However, the C8 slot cannot provide both 12X DDR and PCIe cable ports.
- The port card type installed in the C1 slot can differ from the port card type installed in the C8 slot.
- The server contains a serial-attached SCSI (SAS) port.
- Support for disk drive enclosures, as shown in the following figure, is as follows:
  - The server contains a SAS port.
- Support for PCIe storage enclosures, as shown in the following figure, is as follows:
  - The card installed in the C1 slot can contain two PCIe cable ports. However, the C1 slot cannot provide both PCIe and 12X DDR cable ports.
  - The card installed in the C8 slot can contain two PCIe cable ports. However, the C8 slot cannot provide both PCIe and 12X DDR cable ports.
  - The port card type installed in the C1 slot can differ from the port card type installed in the C8 slot.
  - The server contains a SAS port.

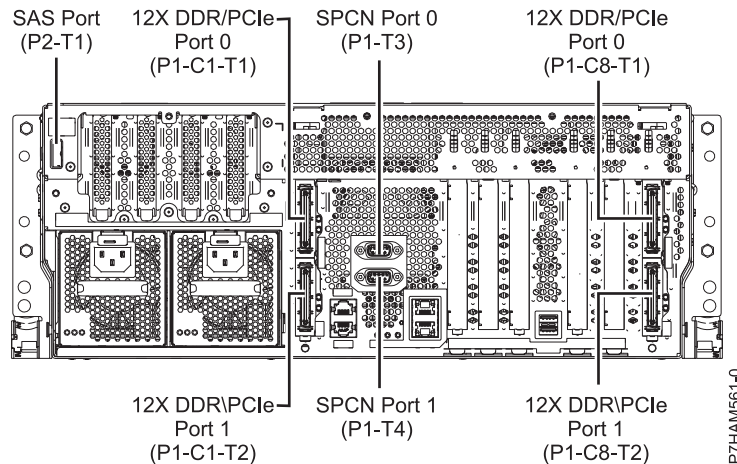

Figure 27. Model 8205-E6D connections for expansion units, disk drive enclosures, and PCIe storage enclosures

## Model 8231-E1D or 8268-E1D connector locations

Learn about connector locations.

The 8231-E1D or 8268-E1D servers provides cable connector locations for the following enclosures:

- Support for disk drive enclosures, as shown in the following figure, is as follows:
  - The server contains a serial-attached SCSI (SAS) port.
- Support for PCIe storage enclosures, as shown in the following figure, is as follows:
  - The card installed in the C1 slot can contain one PCIe cable port.
  - The server contains a SAS port.

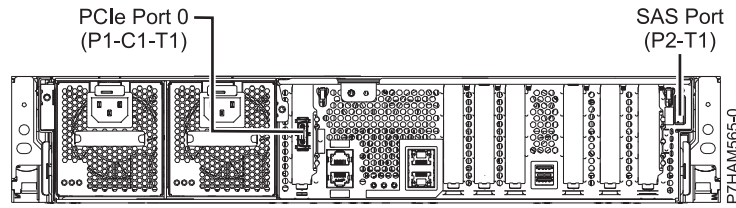

Figure 28. Model 8231-E1D or 8268-E1D connections for disk drive enclosures and PCIe storage enclosures

## Model 8231-E2D connector locations

Learn about connector locations.

The 8231-E2D server provides cable connector locations for the following enclosures:

- Support for expansion units, as shown in the following figure, is as follows:
  - The C1 slot must contain the system power control network (SPCN) card, and the C8 slot must contain the card with two 12X double data rate (DDR) cable ports.

**Note:** Installing the 12X DDR cable ports at this location causes both the C8 and C6 slot space to be occupied.

- The server cannot support both 12X DDR cable ports and PCIe cable ports at the same time.
- The server contains a serial-attached SCSI (SAS) port.
- Support for disk drive enclosures, as shown in the following figure, is as follows:
  - The server contains a SAS port.

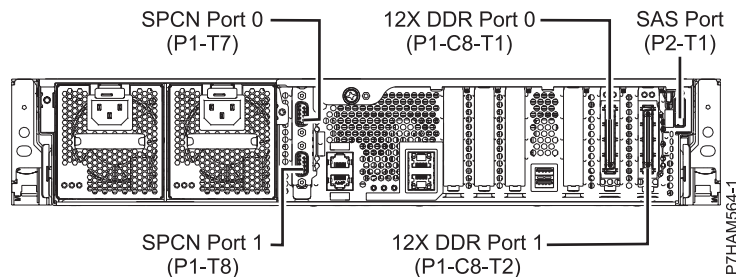

Figure 29. Model 8231-E2D connections for expansion units and disk drive enclosures

- Support for PCIe storage enclosures, as shown in the following figure, is as follows:
  - The card installed in the C1 slot can contain one PCIe cable port, and the card installed in the C8 slot can contain one PCIe cable port.
  - The server cannot support both PCIe cable ports and 12X DDR cable ports at the same time.
  - The server contains a SAS port.

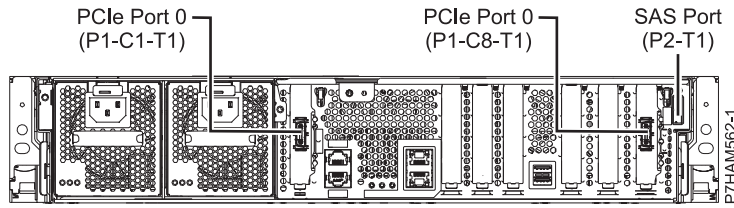

Figure 30. Model 8231-E2D connections for PCIe storage enclosures

## Model 8248-L4T, 8408-E8D, or 9109-RMD connector locations

Learn about connector locations.

The 8248-L4T, 8408-E8D, and 9109-RMD servers provide cable connector locations for the following enclosures:

- Support for expansion units, as shown in the following figure, is as follows:
  - The card installed in the C2 slot can contain two 12X double data rate (DDR) cable ports. However, the C2 slot cannot provide both 12X DDR and PCIe cable ports.
  - The card installed in the C3 slot can contain two 12X DDR cable ports. However, the C3 slot cannot provide both 12X DDR and PCIe cable ports.
- Support for disk drive enclosures, as shown in the following figure, is as follows:
  - The server contains a SAS port.
- Support for PCIe storage enclosures, as shown in the following figure, is as follows:
  - The card installed in the C2 slot can contain two PCIe cable ports. However, the C2 slot cannot provide both PCIe and 12X DDR cable ports.
  - The card installed in the C3 slot can contain two PCIe cable ports. However, the C3 slot cannot provide both PCIe and 12X DDR cable ports.

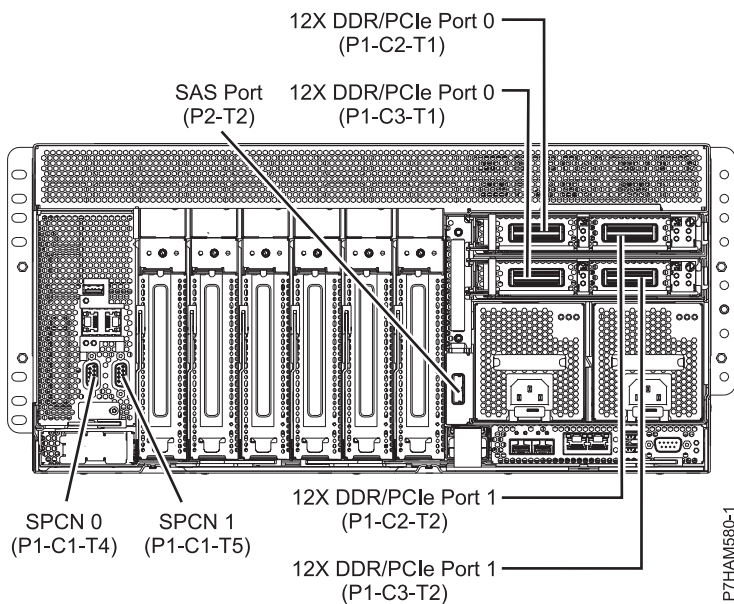

Figure 31. Model 8248-L4T, 8408-E8D, or 9109-RMD connector locations for expansion units, disk drive enclosures, and PCIe storage enclosures

## Model 8412-EAD connector locations

Learn about connector locations.

The 8412-EAD server provides cable connector locations for the following enclosures:

- Support for expansion units, as shown in the following figure, is as follows:
  - The card installed in the C2 slot can contain two 12X double data rate (DDR) cable ports. However, the C2 slot cannot provide both 12X DDR and PCIe cable ports.
  - The card installed in the C3 slot can contain two 12X DDR cable ports. However, the C3 slot cannot provide both 12X DDR and PCIe cable ports.
- Support for disk drive enclosures, as shown in the following figure, is as follows:
  - The server contains a SAS port.
- Support for PCIe storage enclosures, as shown in the following figure, is as follows:
  - The card installed in the C2 slot can contain two PCIe cable ports. However, the C2 slot cannot provide both PCIe and 12X DDR cable ports.
  - The card installed in the C3 slot can contain two PCIe cable ports. However, the C3 slot cannot provide both PCIe and 12X DDR cable ports.

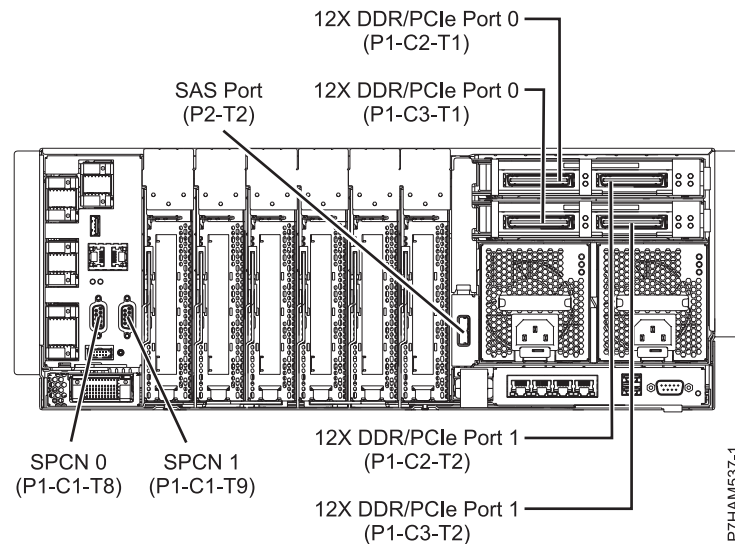

Figure 32. Model 8412-EAD connector locations for expansion units, disk drive enclosures, and PCIe storage enclosures

## Model 9117-MMD or 9179-MHD connector locations

Learn about connector locations.

The 9117-MMD and 9179-MHD servers provide cable connector locations for the following enclosures:

- Support for expansion units, as shown in the following figure, is as follows:
  - The card installed in the C2 slot can contain two 12X double data rate (DDR) cable ports. However, the C2 slot cannot provide both 12X DDR and PCIe cable ports.
  - The card installed in the C3 slot can contain two 12X DDR cable ports. However, the C3 slot cannot provide both 12X DDR and PCIe cable ports.
- Support for disk drive enclosures, as shown in the following figure, is as follows:
  - The server contains a SAS port.
- Support for PCIe storage enclosures, as shown in the following figure, is as follows:
  - The card installed in the C2 slot can contain two PCIe cable ports. However, the C2 slot cannot provide both PCIe and 12X DDR cable ports.

- The card installed in the C3 slot can contain two PCIe cable ports. However, the C3 slot cannot provide both PCIe and 12X DDR cable ports.

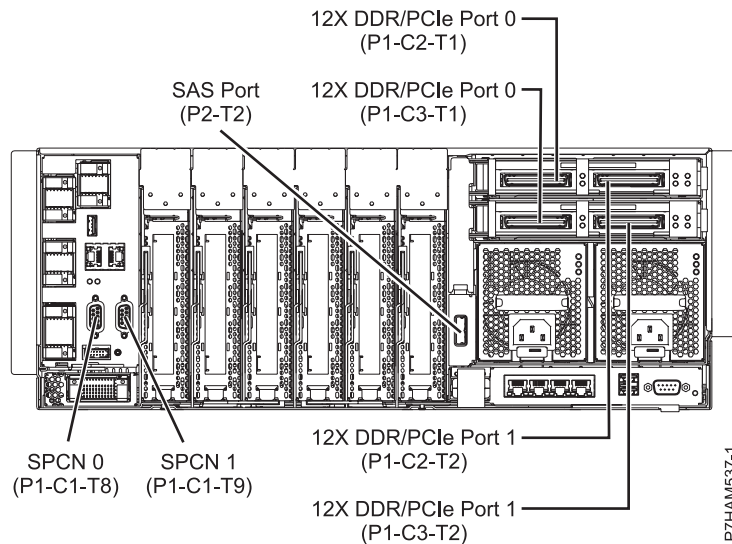

Figure 33. Model 9117-MMD or 9179-MHD connector locations for expansion units, disk drive enclosures, and PCIe storage enclosures

## Enclosure connectors

Learn about connector locations for I/O enclosures.

### Model EDR1 connector locations

Learn about connector locations.

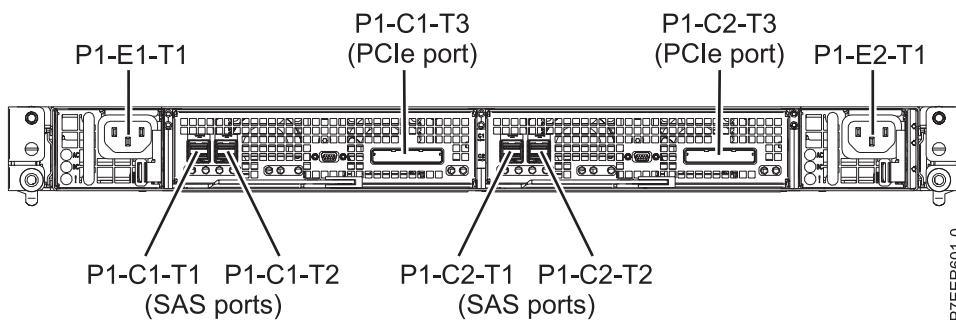

Figure 34. Model EDR1 connector locations

## Model 5887 connector locations

Learn about connector locations.

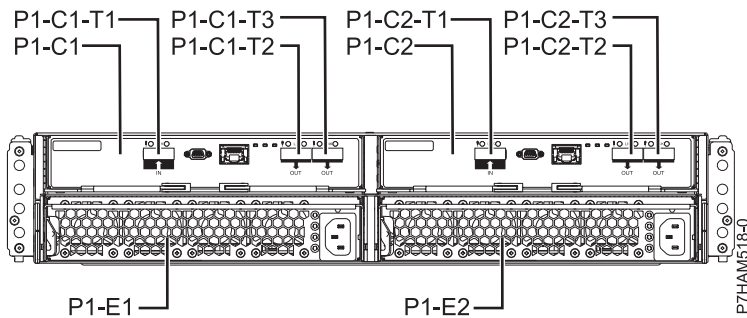

Figure 35. Model 5887 connector locations

## Cabling the PCIe storage enclosure

Use this information as a guide for cabling your storage enclosure.

### Cabling the EDR1 PCIe storage enclosure to an 8202-E4D or 8205-E6D system

Use this information as a guide for cabling your PCIe storage enclosure to an 8202-E4D or 8205-E6D system.

Figure 36 on page 28 shows one EDR1 PCIe storage enclosure connected to a single 8202-E4D or 8205-E6D system by using one feature code (FC) EJ03 PCIe2 GX++ adapter and two PCIe cables.

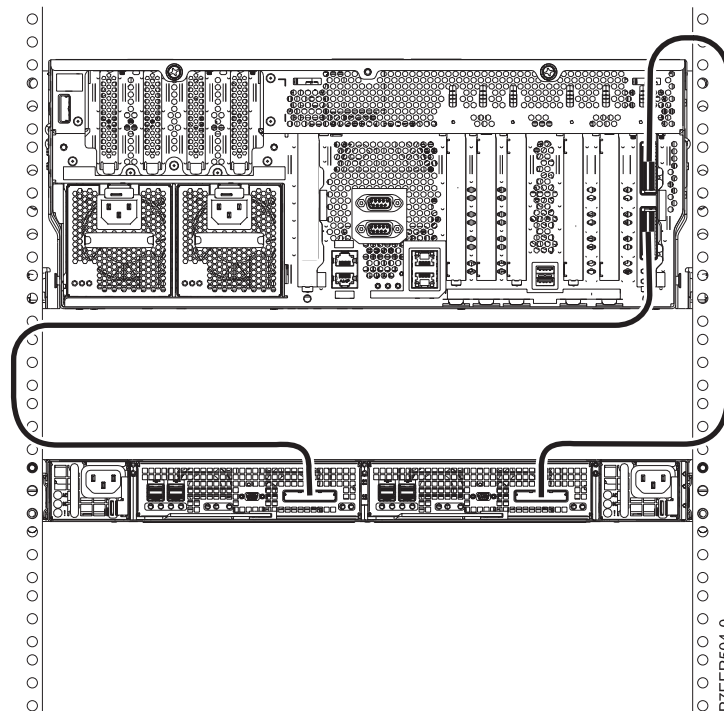

Figure 36. One EDR1 PCIe storage enclosure connected to a single 8202-E4D or 8205-E6D system by using one FC EJ03 PCIe2 GX++ adapter and two PCIe cables

Figure 37 shows one EDR1 PCIe storage enclosure connected to an 8205-E6D system by using two FC EJ03 PCIe2 GX++ adapters and two PCIe cables.

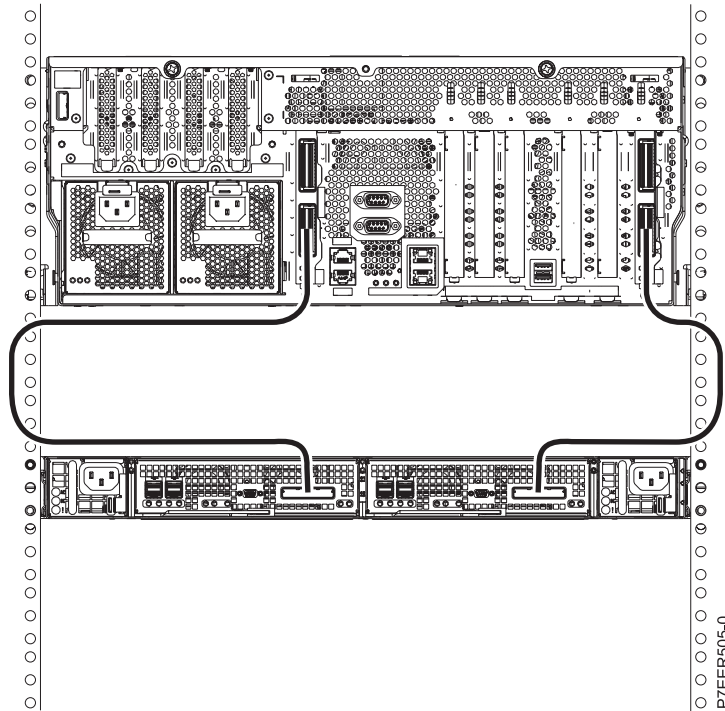

Figure 37. One EDR1 PCIe storage enclosure connected to a single 8205-E6D system by using two FC EJ03 PCIe2 GX++ adapters and two PCIe cables

Figure 38 on page 29 shows two EDR1 PCIe storage enclosures connected to a single 8205-E6D system by using two FC EJ03 PCIe2 GX++ adapters and four PCIe cables.



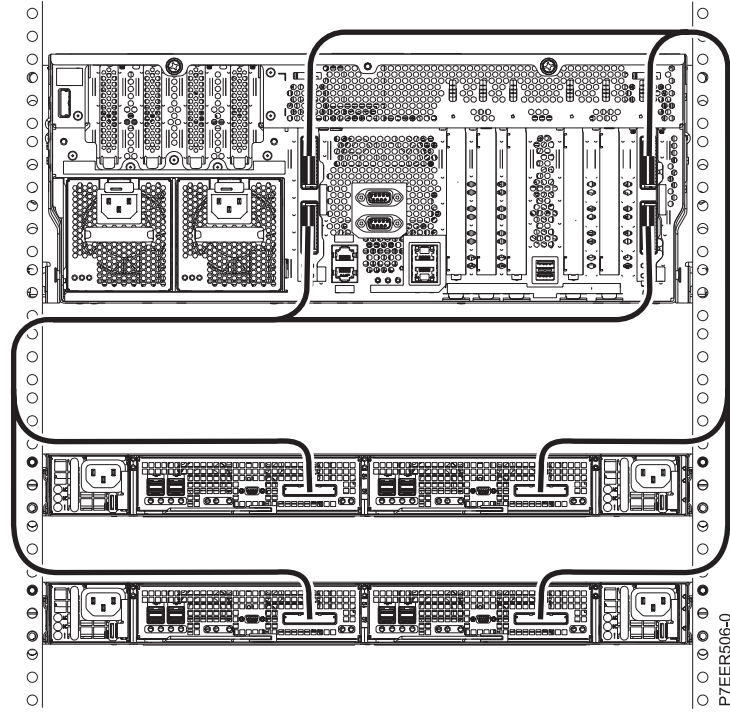

Figure 38. Two EDR1 PCIe storage enclosures connected to a single 8205-E6D system by using two FC EJ03 PCIe2 GX++ adapters and four PCIe cables

Figure 39 on page 30 shows one EDR1 PCIe storage enclosure connected to two 8202-E4D or 8205-E6D systems by using two FC EJ03 PCIe2 GX++ adapters and two PCIe cables.

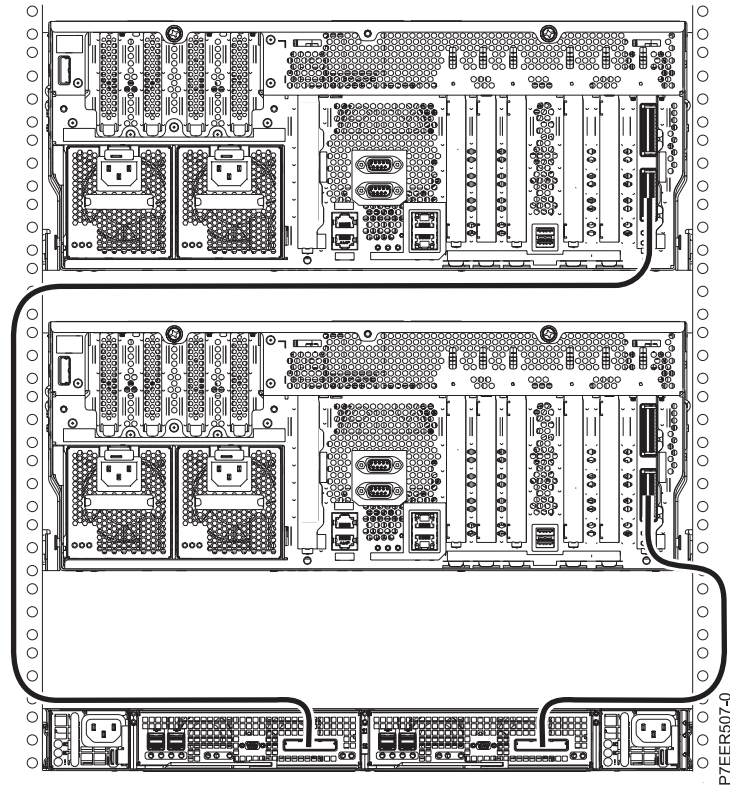

Figure 39. One EDR1 PCIe storage enclosure connected to two 8202-E4D or 8205-E6D systems by using two FC EJ03 PCIe2 GX++ adapters and two PCIe cables

Figure 40 shows two EDR1 PCIe storage enclosures connected to two 8202-E4D or 8205-E6D systems by using two FC EJ03 PCIe2 GX++ adapters and four PCIe cables.

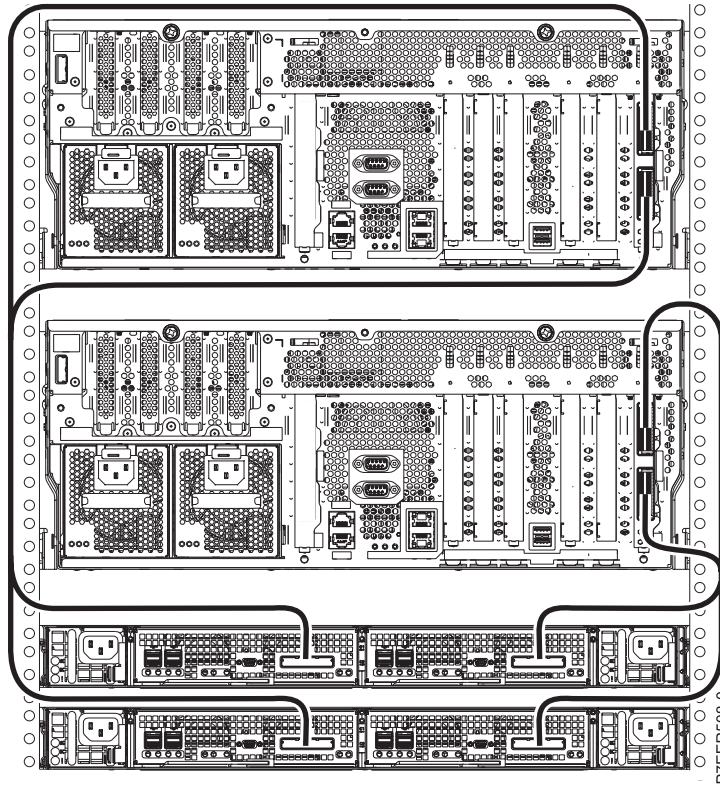

Figure 40. Two EDR1 PCIe storage enclosures connected to two 8202-E4D or 8205-E6D systems by using two FC EJ03 PCIe2 GX++ adapters and four PCIe cables

Figure 41 on page 31 shows four EDR1 PCIe storage enclosures connected to two 8205-E6D systems by using four FC EJ03 PCIe2 GX++ adapters and eight PCIe cables.

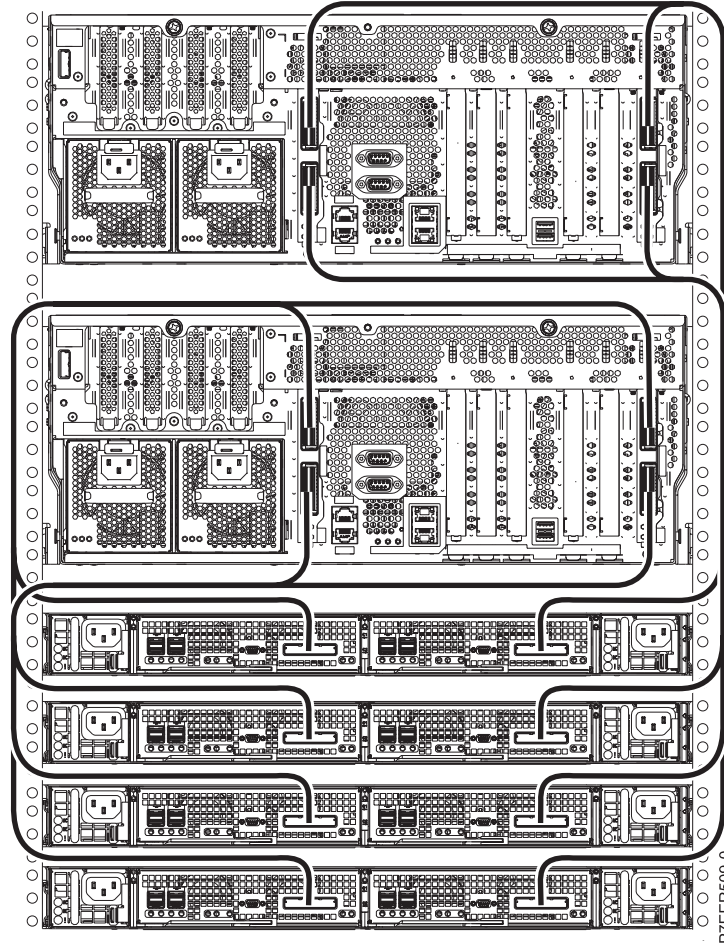

Figure 41. Four EDR1 PCIe storage enclosures connected to two 8205-E6D systems by using four FC EJ03 PCIe2 GX++ adapters and eight PCIe cables

### Cabling the EDR1 PCIe storage enclosure to an 8231-E1D, 8231-E2D, or 8268-E1D system

Use this as a guide for cabling your PCIe storage enclosure to an 8231-E1D, 8231-E2D, or 8268-E1D system.

Figure 42 on page 32 shows an example of connecting an EDR1 PCIe storage enclosure to an 8231-E2D system by using two feature code (FC) EJ0H PCIe2 GX++ adapters and two PCIe cables.

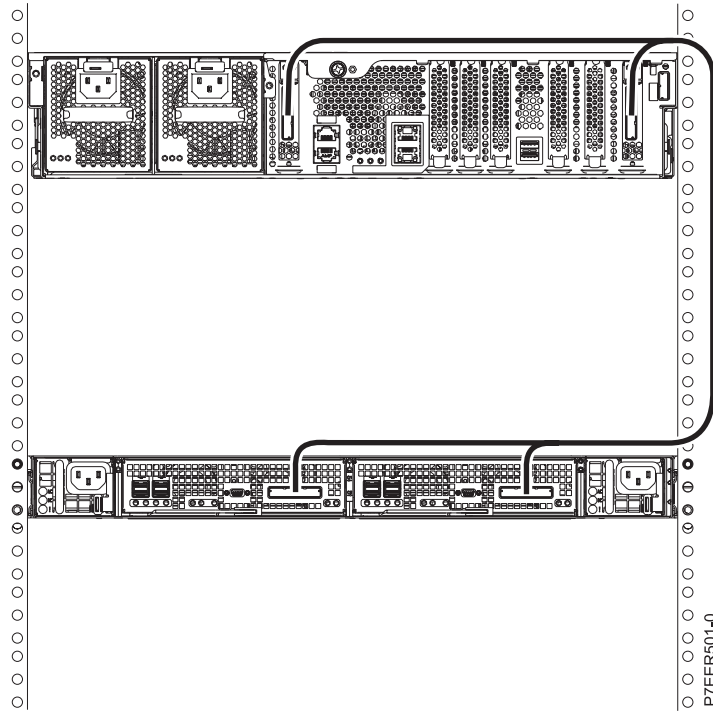

Figure 42. One EDR1 PCIe storage enclosure connected to an 8231-E2D system by using two FC EJ0H PCIe2 GX++ adapters and two PCIe cables

Figure 43 on page 33 shows one EDR1 PCIe storage enclosure connected to two 8231-E1D, 8231-E2D, or 8268-E1D systems by using two FC EJ0H PCIe2 GX++ adapters and two PCIe cables.

**Note:** The 8231-E1D and 8268-E1D must be one of two systems in a high-availability configuration in order to support a PCIe storage enclosure as is shown in Figure 43 on page 33.

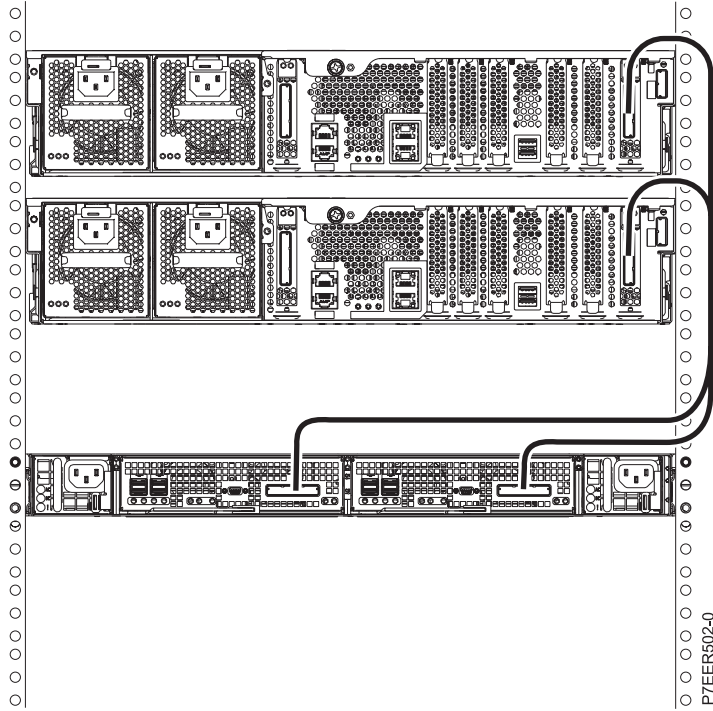

Figure 43. One EDR1 PCIe storage enclosure connected to two 8231-E1D, 8231-E2D, or 8268-E1D systems by using two FC E10H PCIe2 GX++ adapters and two PCIe cables

Figure 44 on page 34 shows two EDR1 PCIe storage enclosures connected to two 8231-E2D systems by using four FC E10H PCIe2 GX++ adapters and four PCIe cables.

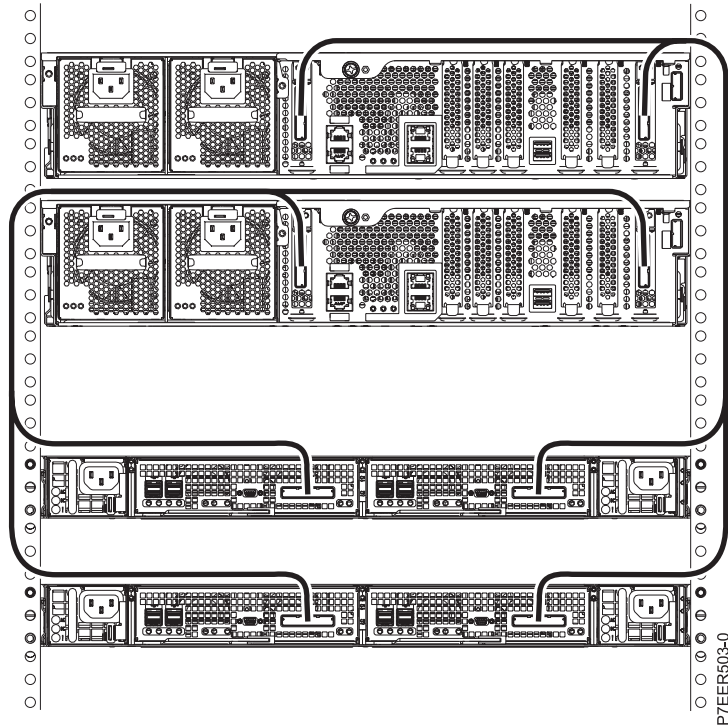

Figure 44. Two EDR1 PCIe storage enclosures connected to two 8231-E2D systems by using four FC EJ0H PCIe2 GX++ adapters and four PCIe cables

## Cabling the EDR1 PCIe storage enclosure to an 8246-L2T system

Use this as a guide for cabling your PCIe storage enclosure to an 8246-L2T system.

Figure 45 shows an example of connecting an EDR1 PCIe storage enclosure to an 8246-L2T system by using two feature code (FC) EJ0H PCIe2 GX++ adapters and two PCIe cables.

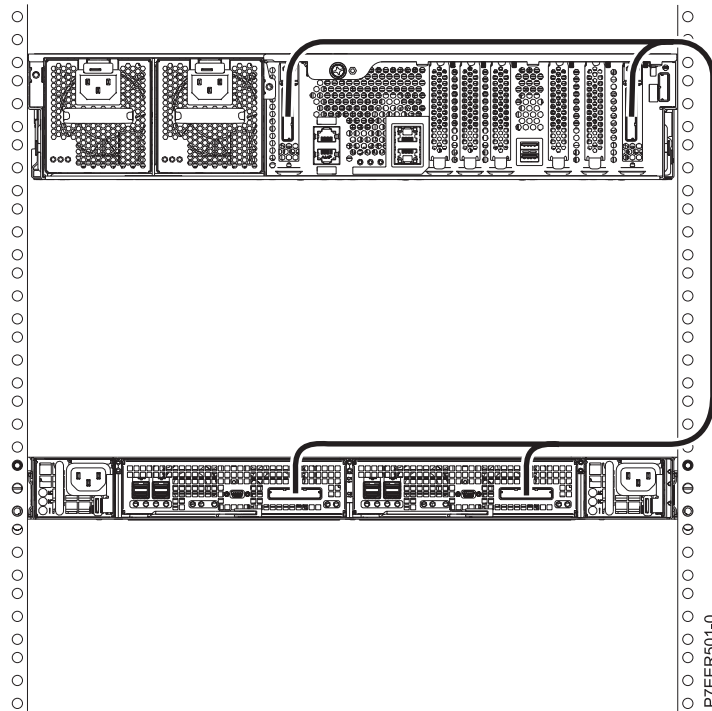

Figure 45. One EDR1 PCIe storage enclosure connected to an 8246-L2T system by using two FC EJ0H PCIe2 GX++ adapters and two PCIe cables

Figure 46 on page 35 shows one EDR1 PCIe storage enclosure connected to two 8246-L2T systems by using two FC EJ0H PCIe2 GX++ adapters and two PCIe cables.

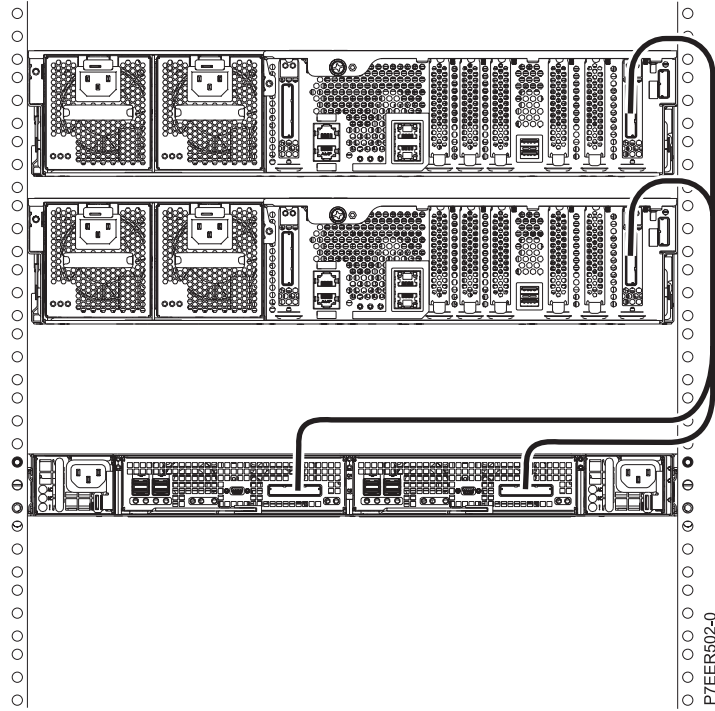

Figure 46. One EDR1 PCIe storage enclosure connected to two 8246-L2T systems by using two FC E10H PCIe2 GX++ adapters and two PCIe cables

Figure 47 on page 36 shows two EDR1 PCIe storage enclosures connected to two 8246-L2T systems by using four FC E10H PCIe2 GX++ adapters and four PCIe cables.

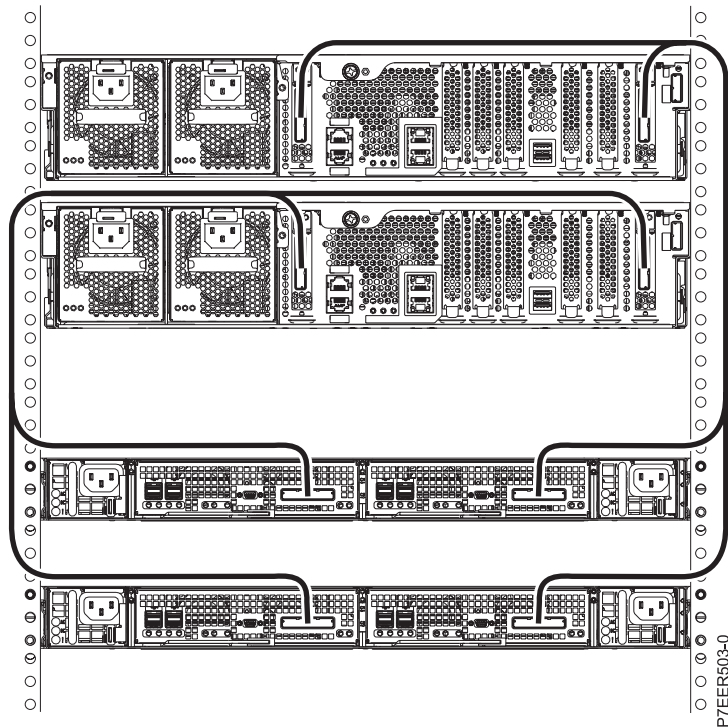

Figure 47. Two EDR1 PCIe storage enclosures connected to two 8246-L2T systems by using four FC EJ0H PCIe2 GX++ adapters and four PCIe cables

## Cabling the EDR1 PCIe storage enclosure to an 8248-L4T, 8408-E8D, or 9109-RMD system

Use this information as a guide for cabling your PCIe storage enclosure to an 8248-L4T, 8408-E8D, or 9109-RMD system.

Figure 48 shows one EDR1 PCIe storage enclosure connected to a single 8248-L4T, 8408-E8D, or 9109-RMD system by using one feature code (FC) 1914 PCIe2 GX++ adapter and two PCIe cables.

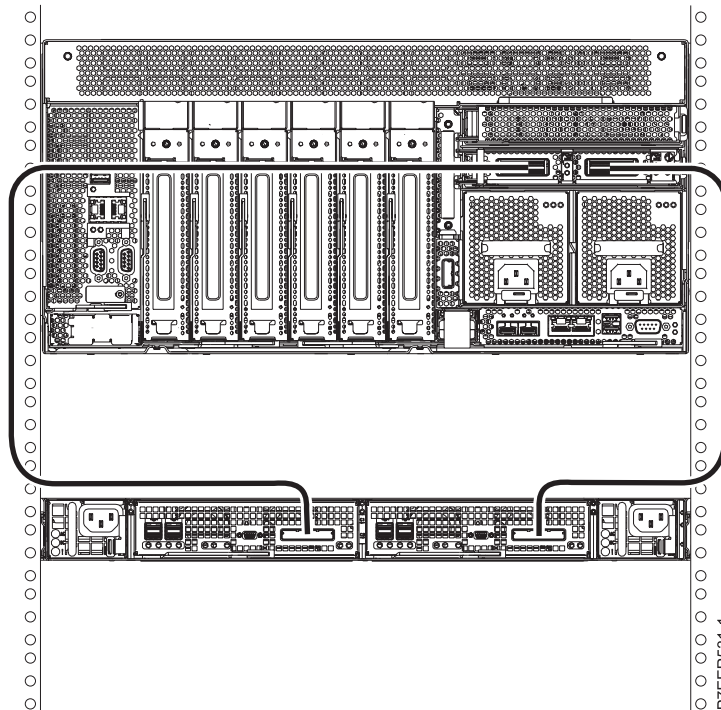

Figure 48. One EDR1 PCIe storage enclosure connected to a single 8248-L4T, 8408-E8D, or 9109-RMD system by using one FC 1914 PCIe2 GX++ adapter and two PCIe cables

Figure 49 on page 37 shows one EDR1 PCIe storage enclosure connected to a single 8248-L4T, 8408-E8D, or 9109-RMD system by using two FC 1914 PCIe2 GX++ adapters and two PCIe cables.



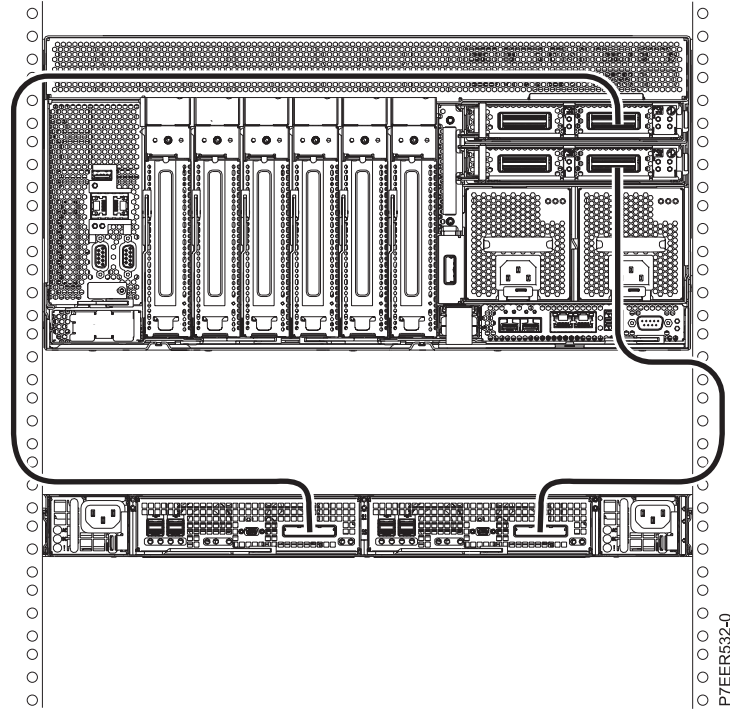

Figure 49. One EDR1 PCIe storage enclosure connected to a single 8248-L4T, 8408-E8D, or 9109-RMD system by using two FC 1914 PCIe2 GX++ adapters and two PCIe cables

Figure 50 on page 38 shows two EDR1 PCIe storage enclosures connected to a single 8248-L4T, 8408-E8D, or 9109-RMD system by using two FC 1914 PCIe2 GX++ adapters and four PCIe cables.

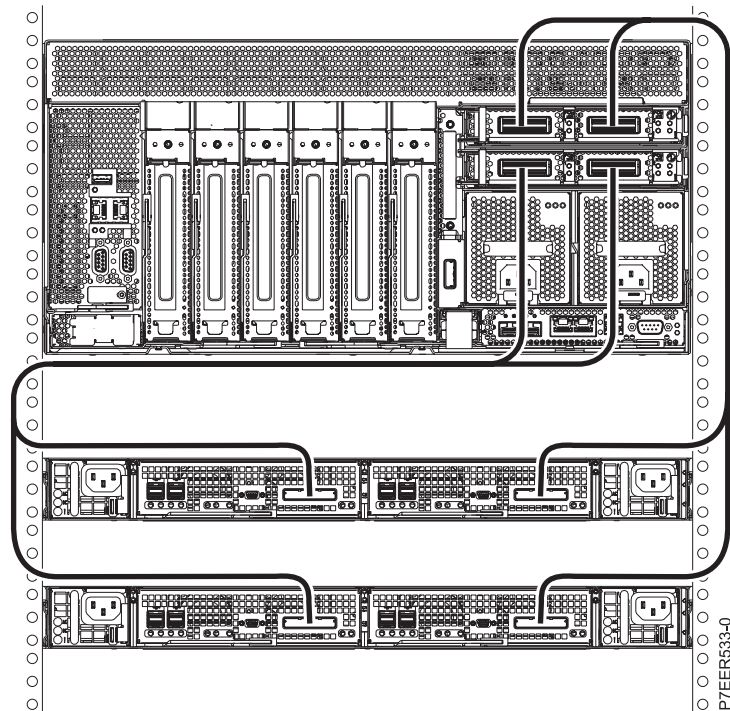

Figure 50. Two EDR1 PCIe storage enclosures connected to a single 8248-L4T, 8408-E8D, or 9109-RMD system by using two FC 1914 PCIe2 GX++ adapters and four PCIe cables

## Cabling the EDR1 PCIe storage enclosure to an 8412-EAD, 9117-MMC, 9117-MMD, 9179-MHC, or 9179-MHD system

Use this information as a guide for cabling your PCIe storage enclosure to an 8412-EAD, 9117-MMC, 9117-MMD, 9179-MHC, or 9179-MHD system.

Figure 51 shows one EDR1 PCIe storage enclosure connected to a single 8412-EAD, 9117-MMC, 9117-MMD, 9179-MHC, or 9179-MHD system by using one feature code (FC) 1914 PCIe2 GX++ adapter and two PCIe cables.

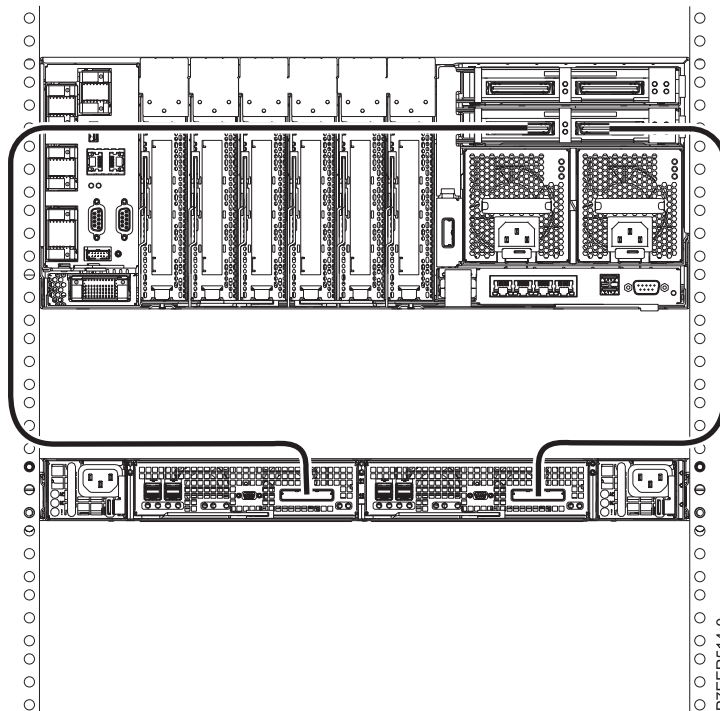

Figure 51. One EDR1 PCIe storage enclosure connected to a single 8412-EAD, 9117-MMC, 9117-MMD, 9179-MHC, or 9179-MHD system by using one FC 1914 PCIe2 GX++ adapter and two PCIe cables

Figure 52 on page 39 shows one EDR1 PCIe storage enclosure connected to an 8412-EAD, 9117-MMC, 9117-MMD, 9179-MHC, or 9179-MHD system by using two FC 1914 PCIe2 GX++ adapters and two PCIe cables.

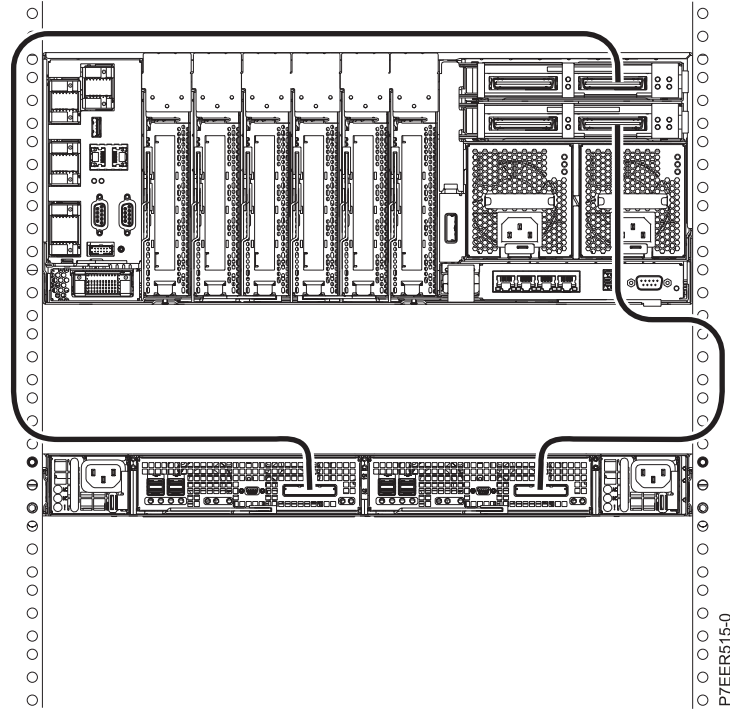

Figure 52. One EDR1 PCIe storage enclosure connected to a single 8412-EAD, 9117-MMC, 9117-MMD, 9179-MHC, or 9179-MHD system by using two FC 1914 PCIe2 GX++ adapters and two PCIe cables

Figure 53 on page 40 shows two EDR1 PCIe storage enclosures connected to a single 8412-EAD, 9117-MMC, 9117-MMD, 9179-MHC, or 9179-MHD system by using two FC 1914 PCIe2 GX++ adapters and four PCIe cables.

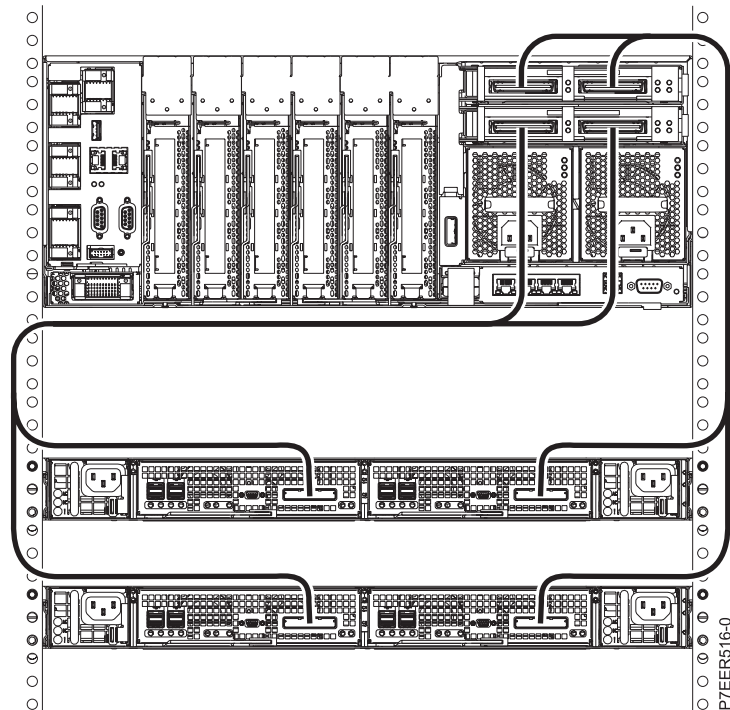

Figure 53. Two EDR1 PCIe storage enclosures connected to a single 8412-EAD, 9117-MMC, 9117-MMD, 9179-MHC, or 9179-MHD system by using two FC 1914 PCIe2 GX++ adapters and four PCIe cables

Figure 54 shows one EDR1 PCIe storage enclosure connected to two 8412-EAD, 9117-MMC, 9117-MMD, 9179-MHC, or 9179-MHD systems by using two FC 1914 PCIe2 GX++ adapters and two PCIe cables.

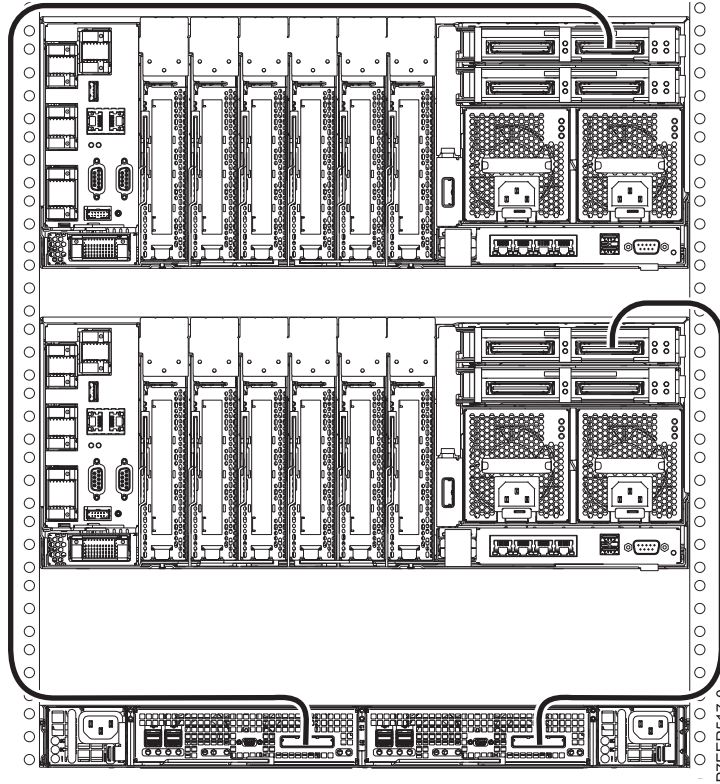

Figure 54. One EDR1 PCIe storage enclosure connected to two 8412-EAD, 9117-MMC, 9117-MMD, 9179-MHC, or 9179-MHD systems by using two FC 1914 PCIe2 GX++ adapters and two PCIe cables

Figure 55 on page 41 shows two EDR1 PCIe storage enclosures connected to two 8412-EAD, 9117-MMC, 9117-MMD, 9179-MHC, or 9179-MHD systems by using two FC 1914 PCIe2 GX++ adapters and four PCIe cables.

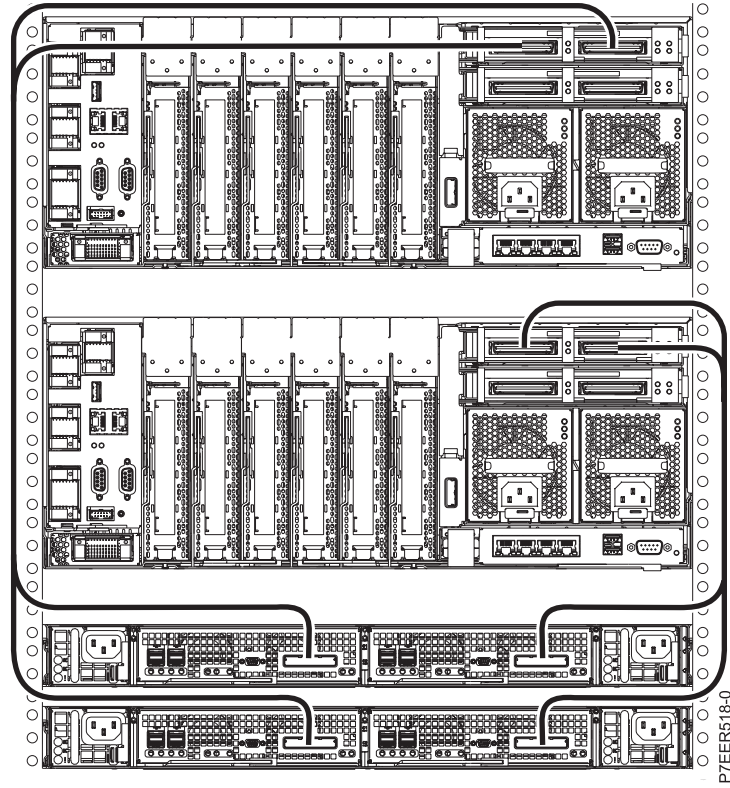

Figure 55. Two EDR1 PCIe storage enclosures connected to two 8412-EAD, 9117-MMC, 9117-MMD, 9179-MHC, or 9179-MHD systems by using two FC 1914 PCIe2 GX++ adapters and four PCIe cables

Figure 56 on page 42 shows four EDR1 PCIe storage enclosures connected to two 8412-EAD, 9117-MMC, 9117-MMD, 9179-MHC, or 9179-MHD systems by using four FC 1914 PCIe2 GX++ adapters and eight PCIe cables.

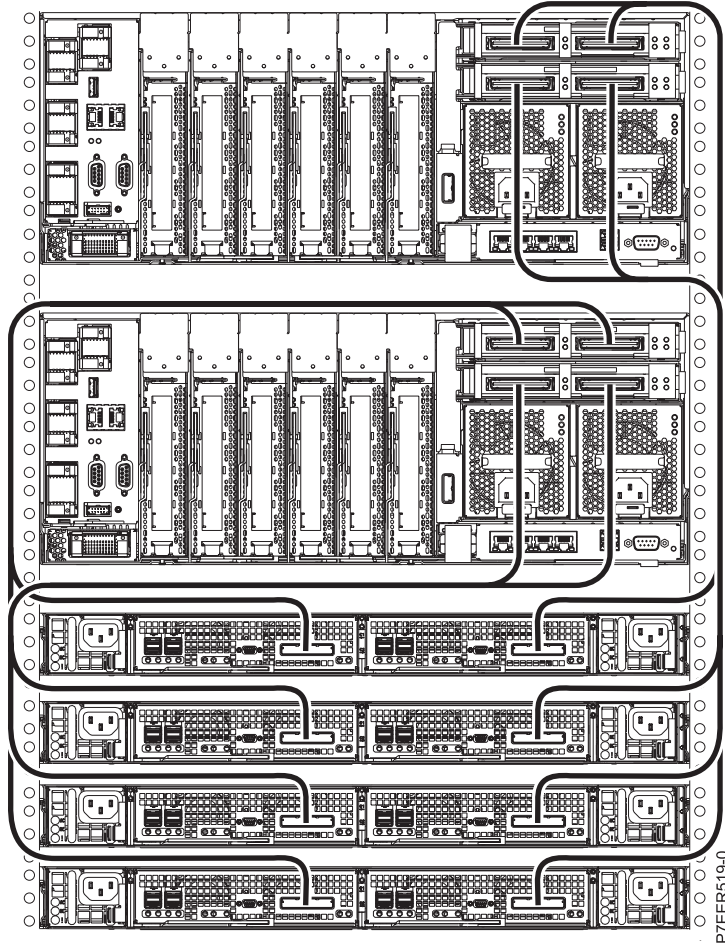

Figure 56. Four EDR1 PCIe storage enclosures connected to two 8412-EAD, 9117-MMC, 9117-MMD, 9179-MHC, or 9179-MHD systems by using four FC 1914 PCIe2 GX++ adapters and eight PCIe cables

---

## Notices

This information was developed for products and services offered in the U.S.A.

The manufacturer may not offer the products, services, or features discussed in this document in other countries. Consult the manufacturer's representative for information on the products and services currently available in your area. Any reference to the manufacturer's product, program, or service is not intended to state or imply that only that product, program, or service may be used. Any functionally equivalent product, program, or service that does not infringe any intellectual property right of the manufacturer may be used instead. However, it is the user's responsibility to evaluate and verify the operation of any product, program, or service.

The manufacturer may have patents or pending patent applications covering subject matter described in this document. The furnishing of this document does not grant you any license to these patents. You can send license inquiries, in writing, to the manufacturer.

**The following paragraph does not apply to the United Kingdom or any other country where such provisions are inconsistent with local law:** THIS PUBLICATION IS PROVIDED "AS IS" WITHOUT WARRANTY OF ANY KIND, EITHER EXPRESS OR IMPLIED, INCLUDING, BUT NOT LIMITED TO, THE IMPLIED WARRANTIES OF NON-INFRINGEMENT, MERCHANTABILITY OR FITNESS FOR A PARTICULAR PURPOSE. Some states do not allow disclaimer of express or implied warranties in certain transactions, therefore, this statement may not apply to you.

This information could include technical inaccuracies or typographical errors. Changes are periodically made to the information herein; these changes will be incorporated in new editions of the publication. The manufacturer may make improvements and/or changes in the product(s) and/or the program(s) described in this publication at any time without notice.

Any references in this information to websites not owned by the manufacturer are provided for convenience only and do not in any manner serve as an endorsement of those websites. The materials at those websites are not part of the materials for this product and use of those websites is at your own risk.

The manufacturer may use or distribute any of the information you supply in any way it believes appropriate without incurring any obligation to you.

Any performance data contained herein was determined in a controlled environment. Therefore, the results obtained in other operating environments may vary significantly. Some measurements may have been made on development-level systems and there is no guarantee that these measurements will be the same on generally available systems. Furthermore, some measurements may have been estimated through extrapolation. Actual results may vary. Users of this document should verify the applicable data for their specific environment.

Information concerning products not produced by this manufacturer was obtained from the suppliers of those products, their published announcements or other publicly available sources. This manufacturer has not tested those products and cannot confirm the accuracy of performance, compatibility or any other claims related to products not produced by this manufacturer. Questions on the capabilities of products not produced by this manufacturer should be addressed to the suppliers of those products.

All statements regarding the manufacturer's future direction or intent are subject to change or withdrawal without notice, and represent goals and objectives only.

The manufacturer's prices shown are the manufacturer's suggested retail prices, are current and are subject to change without notice. Dealer prices may vary.

This information is for planning purposes only. The information herein is subject to change before the products described become available.

This information contains examples of data and reports used in daily business operations. To illustrate them as completely as possible, the examples include the names of individuals, companies, brands, and products. All of these names are fictitious and any similarity to the names and addresses used by an actual business enterprise is entirely coincidental.

If you are viewing this information in softcopy, the photographs and color illustrations may not appear.

The drawings and specifications contained herein shall not be reproduced in whole or in part without the written permission of the manufacturer.

The manufacturer has prepared this information for use with the specific machines indicated. The manufacturer makes no representations that it is suitable for any other purpose.

The manufacturer's computer systems contain mechanisms designed to reduce the possibility of undetected data corruption or loss. This risk, however, cannot be eliminated. Users who experience unplanned outages, system failures, power fluctuations or outages, or component failures must verify the accuracy of operations performed and data saved or transmitted by the system at or near the time of the outage or failure. In addition, users must establish procedures to ensure that there is independent data verification before relying on such data in sensitive or critical operations. Users should periodically check the manufacturer's support websites for updated information and fixes applicable to the system and related software.

## Homologation statement

This product may not be certified in your country for connection by any means whatsoever to interfaces of public telecommunications networks. Further certification may be required by law prior to making any such connection. Contact an IBM representative or reseller for any questions.

---

## Trademarks

IBM, the IBM logo, and [ibm.com](http://ibm.com) are trademarks or registered trademarks of International Business Machines Corp., registered in many jurisdictions worldwide. Other product and service names might be trademarks of IBM or other companies. A current list of IBM trademarks is available on the web at Copyright and trademark information at [www.ibm.com/legal/copytrade.shtml](http://www.ibm.com/legal/copytrade.shtml).

Linux is a registered trademark of Linus Torvalds in the United States, other countries, or both.

---

## Electronic emission notices

When attaching a monitor to the equipment, you must use the designated monitor cable and any interference suppression devices supplied with the monitor.

## Class A Notices

The following Class A statements apply to the IBM servers that contain the POWER7<sup>®</sup> processor and its features unless designated as electromagnetic compatibility (EMC) Class B in the feature information.

## Federal Communications Commission (FCC) statement

**Note:** This equipment has been tested and found to comply with the limits for a Class A digital device, pursuant to Part 15 of the FCC Rules. These limits are designed to provide reasonable protection against harmful interference when the equipment is operated in a commercial environment. This equipment generates, uses, and can radiate radio frequency energy and, if not installed and used in accordance with



the instruction manual, may cause harmful interference to radio communications. Operation of this equipment in a residential area is likely to cause harmful interference, in which case the user will be required to correct the interference at his own expense.

Properly shielded and grounded cables and connectors must be used in order to meet FCC emission limits. IBM is not responsible for any radio or television interference caused by using other than recommended cables and connectors or by unauthorized changes or modifications to this equipment. Unauthorized changes or modifications could void the user's authority to operate the equipment.

This device complies with Part 15 of the FCC rules. Operation is subject to the following two conditions: (1) this device may not cause harmful interference, and (2) this device must accept any interference received, including interference that may cause undesired operation.

### **Industry Canada Compliance Statement**

This Class A digital apparatus complies with Canadian ICES-003.

### **Avis de conformité à la réglementation d'Industrie Canada**

Cet appareil numérique de la classe A est conforme à la norme NMB-003 du Canada.

### **European Community Compliance Statement**

This product is in conformity with the protection requirements of EU Council Directive 2004/108/EC on the approximation of the laws of the Member States relating to electromagnetic compatibility. IBM cannot accept responsibility for any failure to satisfy the protection requirements resulting from a non-recommended modification of the product, including the fitting of non-IBM option cards.

This product has been tested and found to comply with the limits for Class A Information Technology Equipment according to European Standard EN 55022. The limits for Class A equipment were derived for commercial and industrial environments to provide reasonable protection against interference with licensed communication equipment.

European Community contact:  
IBM Deutschland GmbH  
Technical Regulations, Department M372  
IBM-Allee 1, 71139 Ehningen, Germany  
Tele: +49 7032 15 2941  
email: lugi@de.ibm.com

**Warning:** This is a Class A product. In a domestic environment, this product may cause radio interference, in which case the user may be required to take adequate measures.

### **VCCI Statement - Japan**

この装置は、クラスA 情報技術装置です。この装置を家庭環境で使用すると電波妨害を引き起こすことがあります。この場合には使用者が適切な対策を講ずるよう要求されることがあります。

VCCI-A

The following is a summary of the VCCI Japanese statement in the box above:

This is a Class A product based on the standard of the VCCI Council. If this equipment is used in a domestic environment, radio interference may occur, in which case, the user may be required to take corrective actions.

### **Japanese Electronics and Information Technology Industries Association (JEITA) Confirmed Harmonics Guideline (products less than or equal to 20 A per phase)**

高調波ガイドライン適合品

### **Japanese Electronics and Information Technology Industries Association (JEITA) Confirmed Harmonics Guideline with Modifications (products greater than 20 A per phase)**

高調波ガイドライン準用品

### **Electromagnetic Interference (EMI) Statement - People's Republic of China**

#### **声 明**

此为 A 级产品,在生活环境中,  
该产品可能会造成无线电干扰。  
在这种情况下,可能需要用户对其  
干扰采取切实可行的措施。

Declaration: This is a Class A product. In a domestic environment this product may cause radio interference in which case the user may need to perform practical action.

### **Electromagnetic Interference (EMI) Statement - Taiwan**

#### **警告使用者：**

這是甲類的資訊產品，在  
居住的環境中使用時，可  
能會造成射頻干擾，在這  
種情況下，使用者會被要  
求採取某些適當的對策。

The following is a summary of the EMI Taiwan statement above.

Warning: This is a Class A product. In a domestic environment this product may cause radio interference in which case the user will be required to take adequate measures.

#### **IBM Taiwan Contact Information:**

台灣IBM 產品服務聯絡方式：  
台灣國際商業機器股份有限公司  
台北市松仁路7號3樓  
電話：0800-016-888

### **Electromagnetic Interference (EMI) Statement - Korea**

이 기기는 업무용(A급)으로 전자파적합기기로서 판매자 또는 사용자는 이 점을 주의하시기 바라며, 가정외의 지역에서 사용하는 것을 목적으로 합니다.

### **Germany Compliance Statement**

#### **Deutschsprachiger EU Hinweis: Hinweis für Geräte der Klasse A EU-Richtlinie zur Elektromagnetischen Verträglichkeit**

Dieses Produkt entspricht den Schutzanforderungen der EU-Richtlinie 2004/108/EG zur Angleichung der Rechtsvorschriften über die elektromagnetische Verträglichkeit in den EU-Mitgliedsstaaten und hält die Grenzwerte der EN 55022 Klasse A ein.

Um dieses sicherzustellen, sind die Geräte wie in den Handbüchern beschrieben zu installieren und zu betreiben. Des Weiteren dürfen auch nur von der IBM empfohlene Kabel angeschlossen werden. IBM übernimmt keine Verantwortung für die Einhaltung der Schutzanforderungen, wenn das Produkt ohne Zustimmung von IBM verändert bzw. wenn Erweiterungskomponenten von Fremdherstellern ohne Empfehlung von IBM gesteckt/eingebaut werden.

EN 55022 Klasse A Geräte müssen mit folgendem Warnhinweis versehen werden:

"Warnung: Dieses ist eine Einrichtung der Klasse A. Diese Einrichtung kann im Wohnbereich Funk-Störungen verursachen; in diesem Fall kann vom Betreiber verlangt werden, angemessene Maßnahmen zu ergreifen und dafür aufzukommen."

#### **Deutschland: Einhaltung des Gesetzes über die elektromagnetische Verträglichkeit von Geräten**

Dieses Produkt entspricht dem "Gesetz über die elektromagnetische Verträglichkeit von Geräten (EMVG)". Dies ist die Umsetzung der EU-Richtlinie 2004/108/EG in der Bundesrepublik Deutschland.

#### **Zulassungsbescheinigung laut dem Deutschen Gesetz über die elektromagnetische Verträglichkeit von Geräten (EMVG) (bzw. der EMC EG Richtlinie 2004/108/EG) für Geräte der Klasse A**

Dieses Gerät ist berechtigt, in Übereinstimmung mit dem Deutschen EMVG das EG-Konformitätszeichen - CE - zu führen.

Verantwortlich für die Einhaltung der EMV Vorschriften ist der Hersteller:  
International Business Machines Corp.  
New Orchard Road  
Armonk, New York 10504  
Tel: 914-499-1900

Der verantwortliche Ansprechpartner des Herstellers in der EU ist:  
IBM Deutschland GmbH  
Technical Regulations, Abteilung M372  
IBM-Allee 1, 71139 Ehningen, Germany  
Tel: +49 7032 15 2941  
email: lugi@de.ibm.com

Generelle Informationen:

Das Gerät erfüllt die Schutzanforderungen nach EN 55024 und EN 55022 Klasse A.

### **Electromagnetic Interference (EMI) Statement - Russia**

**ВНИМАНИЕ!** Настоящее изделие относится к классу А.  
В жилых помещениях оно может создавать  
радиопомехи, для снижения которых необходимы  
дополнительные меры

### **Class B Notices**

The following Class B statements apply to features designated as electromagnetic compatibility (EMC) Class B in the feature installation information.

### **Federal Communications Commission (FCC) statement**

This equipment has been tested and found to comply with the limits for a Class B digital device, pursuant to Part 15 of the FCC Rules. These limits are designed to provide reasonable protection against harmful interference in a residential installation.

This equipment generates, uses, and can radiate radio frequency energy and, if not installed and used in accordance with the instructions, may cause harmful interference to radio communications. However, there is no guarantee that interference will not occur in a particular installation.

If this equipment does cause harmful interference to radio or television reception, which can be determined by turning the equipment off and on, the user is encouraged to try to correct the interference by one or more of the following measures:

- Reorient or relocate the receiving antenna.
- Increase the separation between the equipment and receiver.
- Connect the equipment into an outlet on a circuit different from that to which the receiver is connected.
- Consult an IBM-authorized dealer or service representative for help.

Properly shielded and grounded cables and connectors must be used in order to meet FCC emission limits. Proper cables and connectors are available from IBM-authorized dealers. IBM is not responsible for

any radio or television interference caused by unauthorized changes or modifications to this equipment. Unauthorized changes or modifications could void the user's authority to operate this equipment.

This device complies with Part 15 of the FCC rules. Operation is subject to the following two conditions: (1) this device may not cause harmful interference, and (2) this device must accept any interference received, including interference that may cause undesired operation.

### **Industry Canada Compliance Statement**

This Class B digital apparatus complies with Canadian ICES-003.

### **Avis de conformité à la réglementation d'Industrie Canada**

Cet appareil numérique de la classe B est conforme à la norme NMB-003 du Canada.

### **European Community Compliance Statement**

This product is in conformity with the protection requirements of EU Council Directive 2004/108/EC on the approximation of the laws of the Member States relating to electromagnetic compatibility. IBM cannot accept responsibility for any failure to satisfy the protection requirements resulting from a non-recommended modification of the product, including the fitting of non-IBM option cards.

This product has been tested and found to comply with the limits for Class B Information Technology Equipment according to European Standard EN 55022. The limits for Class B equipment were derived for typical residential environments to provide reasonable protection against interference with licensed communication equipment.

European Community contact:  
IBM Deutschland GmbH  
Technical Regulations, Department M372  
IBM-Allee 1, 71139 Ehningen, Germany  
Tele: +49 7032 15 2941  
email: lugi@de.ibm.com

### **VCCI Statement - Japan**

この装置は、クラスB情報技術装置です。この装置は、家庭環境で使用することを目的としていますが、この装置がラジオやテレビジョン受信機に近接して使用されると、受信障害を引き起こすことがあります。

取扱説明書に従って正しい取り扱いをして下さい。 VCCI-B

### **Japanese Electronics and Information Technology Industries Association (JEITA) Confirmed Harmonics Guideline (products less than or equal to 20 A per phase)**

高調波ガイドライン適合品

**Japanese Electronics and Information Technology Industries Association (JEITA)  
Confirmed Harmonics Guideline with Modifications (products greater than 20 A per  
phase)**

高調波ガイドライン準用品

**IBM Taiwan Contact Information**

台灣IBM 產品服務聯絡方式：  
台灣國際商業機器股份有限公司  
台北市松仁路7號3樓  
電話：0800-016-888

**Electromagnetic Interference (EMI) Statement - Korea**

이 기기는 가정용(B급)으로 전자파적합기기로서 주로 가정에서 사용하는 것을 목적으로 하며, 모든 지역에서 사용할 수 있습니다.

**Germany Compliance Statement**

**Deutschsprachiger EU Hinweis: Hinweis für Geräte der Klasse B EU-Richtlinie zur  
Elektromagnetischen Verträglichkeit**

Dieses Produkt entspricht den Schutzanforderungen der EU-Richtlinie 2004/108/EG zur Angleichung der Rechtsvorschriften über die elektromagnetische Verträglichkeit in den EU-Mitgliedsstaaten und hält die Grenzwerte der EN 55022 Klasse B ein.

Um dieses sicherzustellen, sind die Geräte wie in den Handbüchern beschrieben zu installieren und zu betreiben. Des Weiteren dürfen auch nur von der IBM empfohlene Kabel angeschlossen werden. IBM übernimmt keine Verantwortung für die Einhaltung der Schutzanforderungen, wenn das Produkt ohne Zustimmung von IBM verändert bzw. wenn Erweiterungskomponenten von Fremdherstellern ohne Empfehlung von IBM gesteckt/eingebaut werden.

**Deutschland: Einhaltung des Gesetzes über die elektromagnetische Verträglichkeit von Geräten**

Dieses Produkt entspricht dem "Gesetz über die elektromagnetische Verträglichkeit von Geräten (EMVG)". Dies ist die Umsetzung der EU-Richtlinie 2004/108/EG in der Bundesrepublik Deutschland.

**Zulassungsbescheinigung laut dem Deutschen Gesetz über die elektromagnetische Verträglichkeit von  
Geräten (EMVG) (bzw. der EMC EG Richtlinie 2004/108/EG) für Geräte der Klasse B**

Dieses Gerät ist berechtigt, in Übereinstimmung mit dem Deutschen EMVG das EG-Konformitätszeichen - CE - zu führen.

Verantwortlich für die Einhaltung der EMV Vorschriften ist der Hersteller:  
International Business Machines Corp.  
New Orchard Road  
Armonk, New York 10504  
Tel: 914-499-1900

Der verantwortliche Ansprechpartner des Herstellers in der EU ist:  
IBM Deutschland GmbH  
Technical Regulations, Abteilung M372  
IBM-Allee 1, 71139 Ehningen, Germany  
Tel: +49 7032 15 2941  
email: lugi@de.ibm.com

Generelle Informationen:

**Das Gerät erfüllt die Schutzanforderungen nach EN 55024 und EN 55022 Klasse B.**

---

## Terms and conditions

Permissions for the use of these publications are granted subject to the following terms and conditions.

**Applicability:** These terms and conditions are in addition to any terms of use for the IBM website.

**Personal Use:** You may reproduce these publications for your personal, noncommercial use provided that all proprietary notices are preserved. You may not distribute, display or make derivative works of these publications, or any portion thereof, without the express consent of IBM.

**Commercial Use:** You may reproduce, distribute and display these publications solely within your enterprise provided that all proprietary notices are preserved. You may not make derivative works of these publications, or reproduce, distribute or display these publications or any portion thereof outside your enterprise, without the express consent of IBM.

**Rights:** Except as expressly granted in this permission, no other permissions, licenses or rights are granted, either express or implied, to the Publications or any information, data, software or other intellectual property contained therein.

IBM reserves the right to withdraw the permissions granted herein whenever, in its discretion, the use of the publications is detrimental to its interest or, as determined by IBM, the above instructions are not being properly followed.

You may not download, export or re-export this information except in full compliance with all applicable laws and regulations, including all United States export laws and regulations.

IBM MAKES NO GUARANTEE ABOUT THE CONTENT OF THESE PUBLICATIONS. THE PUBLICATIONS ARE PROVIDED "AS-IS" AND WITHOUT WARRANTY OF ANY KIND, EITHER EXPRESSED OR IMPLIED, INCLUDING BUT NOT LIMITED TO IMPLIED WARRANTIES OF MERCHANTABILITY, NON-INFRINGEMENT, AND FITNESS FOR A PARTICULAR PURPOSE.









Part Number: 00L5076

Printed in USA

GI11-9879-02



(1P) P/N: 00L5076

