

Power Systems

*Vital product data card for the  
8233-E8B or 8236-E8C*

**IBM**



Power Systems

*Vital product data card for the  
8233-E8B or 8236-E8C*

**IBM**

**Note**

Before using this information and the product it supports, read the information in “Safety notices” on page v, “Notices” on page 69, the *IBM Systems Safety Notices* manual, G229-9054, and the *IBM Environmental Notices and User Guide*, Z125-5823.

This edition applies to IBM Power Systems servers that contain the POWER7 processor and to all associated models.

© Copyright IBM Corporation 2012, 2016.

US Government Users Restricted Rights – Use, duplication or disclosure restricted by GSA ADP Schedule Contract with IBM Corp.

---

# Contents

<b>Safety notices</b> . . . . .	<b>v</b>
---------------------------------	----------

---

<b>Vital product data card</b> . . . . .	<b>1</b>
--	----------

<b>Removing and replacing the 8233-E8B or 8236-E8C vital product data card</b> . . . . .	<b>3</b>
--	----------

Removing the 8233-E8B or 8236-E8C vital product data card . . . . .	3
Installing the 8233-E8B or 8236-E8C vital product data card. . . . .	5

<b>Common procedures for installable features</b> . . . . .	<b>9</b>
---	----------

Before you begin . . . . .	9
Identifying a part . . . . .	11
Control panel LEDs. . . . .	11
Identifying a failing part in an AIX system or logical partition . . . . .	13
Locating a failing part in an AIX system or logical partition . . . . .	13
Activating the indicator light for the failing part . . . . .	13
Deactivating the failing-part indicator light. . . . .	13
Identifying a failing part in an IBM i system or logical partition. . . . .	13
Activating the failing-part indicator light . . . . .	14
Deactivating the failing-part indicator light. . . . .	14
Identifying a failing part in a Linux system or logical partition . . . . .	15
Locating a failing part in a Linux system or logical partition . . . . .	15
Finding the location code of a failing part in a Linux system or logical partition . . . . .	15
Activating the indicator light for the failing part . . . . .	16
Deactivating the failing-part indicator light. . . . .	16
Locating a failing part in a Virtual I/O Server system or logical partition. . . . .	16
Identifying a part by using the Virtual I/O Server . . . . .	16
Starting the system or logical partition . . . . .	17
Starting a system that is not managed by an HMC or an SDMC. . . . .	17
Starting a system or logical partition by using the HMC . . . . .	18
Starting a system or virtual server by using the SDMC . . . . .	18
Stopping a system or logical partition . . . . .	19
Stopping a system that is not managed by an HMC or an SDMC . . . . .	19
Stopping a system by using the HMC . . . . .	20
Stopping a system by using the SDMC . . . . .	21
Enabling enclosure indicators . . . . .	21
Removing and replacing covers for the 8233-E8B or 8236-E8C system . . . . .	22
Removing the front cover from an 8233-E8B or 8236-E8C system . . . . .	22
Installing the front cover on an 8233-E8B or 8236-E8C system . . . . .	22
Removing the service access cover from an 8233-E8B or 8236-E8C system . . . . .	23
Installing the service access cover on an 8233-E8B or 8236-E8C system. . . . .	24
Placing the rack-mounted 8233-E8B or 8236-E8C system into the service position or operating position. . . . .	25
Placing the 8233-E8B or 8236-E8C in the service position . . . . .	25
Placing the 8233-E8B or 8236-E8C in the operating position . . . . .	28
Removing a part by using the HMC . . . . .	30
Installing a part by using the HMC . . . . .	30
Replacing a part by using the HMC . . . . .	31
Removing a part by using the SDMC. . . . .	31
Installing a part by using the SDMC . . . . .	31
Replacing a part by using the SDMC. . . . .	32
Verifying the installed part . . . . .	32
Verifying an installed feature or replaced part in an AIX system or logical partition . . . . .	32
Verifying the installed part in an IBM i system or logical partition . . . . .	35
Deactivating the failing-part indicator light. . . . .	35
Verifying the installed part in a Linux system or logical partition . . . . .	36

Verifying an installed part by using stand-alone diagnostics . . . . .	36
Verifying the installed part by using the HMC. . . . .	37
Activating and deactivating LEDs by using the HMC . . . . .	38
Deactivating a system attention LED or partition LED by using the HMC . . . . .	38
Activating or deactivating an identify LED by using the HMC . . . . .	38
Viewing serviceable events by using the HMC. . . . .	39
Verifying the installed part by using the SDMC . . . . .	40
Activating and deactivating LEDs by using the SDMC . . . . .	40
Deactivating a system attention LED or partition LED by using the SDMC . . . . .	40
Activating or deactivating an identify LED by using the SDMC . . . . .	41
Viewing serviceable events by using the SDMC . . . . .	41
Verifying an installed part or replaced part on a system or logical partition by using Virtual I/O Server tools . . . . .	41
Verifying the installed part by using VIOS . . . . .	41
Verify the replacement part by using VIOS . . . . .	42
Verifying a repair . . . . .	44
Verifying the repair in AIX . . . . .	45
Verifying a repair by using an IBM i system or logical partition . . . . .	48
Verifying the repair in Linux . . . . .	50
Verifying the repair from the management console . . . . .	50
Closing a service call . . . . .	51
Closing a service call by using AIX or Linux . . . . .	56
Closing a service call by using Integrated Virtualization Manager . . . . .	60
Activating and deactivating LEDs . . . . .	64
Deactivating a system attention LED or partition LED by using the management console . . . . .	65
Activating or deactivating an identify LED by using the management console . . . . .	65
Deactivating a system attention LED or logical partition LED by using the Advanced System Management Interface . . . . .	66
Activating or deactivating an identify LED by using the Advanced System Management Interface . . . . .	67
<b>Notices . . . . .</b>	<b>69</b>
Trademarks . . . . .	70
Electronic emission notices . . . . .	70
Class A Notices . . . . .	70
Class B Notices . . . . .	74
Terms and conditions . . . . .	77

---

## Safety notices

Safety notices may be printed throughout this guide:

- **DANGER** notices call attention to a situation that is potentially lethal or extremely hazardous to people.
- **CAUTION** notices call attention to a situation that is potentially hazardous to people because of some existing condition.
- **Attention** notices call attention to the possibility of damage to a program, device, system, or data.

### World Trade safety information

Several countries require the safety information contained in product publications to be presented in their national languages. If this requirement applies to your country, safety information documentation is included in the publications package (such as in printed documentation, on DVD, or as part of the product) shipped with the product. The documentation contains the safety information in your national language with references to the U.S. English source. Before using a U.S. English publication to install, operate, or service this product, you must first become familiar with the related safety information documentation. You should also refer to the safety information documentation any time you do not clearly understand any safety information in the U.S. English publications.

Replacement or additional copies of safety information documentation can be obtained by calling the IBM Hotline at 1-800-300-8751.

### German safety information

Das Produkt ist nicht für den Einsatz an Bildschirmarbeitsplätzen im Sinne § 2 der Bildschirmarbeitsverordnung geeignet.

### Laser safety information

IBM® servers can use I/O cards or features that are fiber-optic based and that utilize lasers or LEDs.

#### Laser compliance

IBM servers may be installed inside or outside of an IT equipment rack.

## DANGER

When working on or around the system, observe the following precautions:

Electrical voltage and current from power, telephone, and communication cables are hazardous. To avoid a shock hazard:

- Connect power to this unit only with the IBM provided power cord. Do not use the IBM provided power cord for any other product.
- Do not open or service any power supply assembly.
- Do not connect or disconnect any cables or perform installation, maintenance, or reconfiguration of this product during an electrical storm.
- The product might be equipped with multiple power cords. To remove all hazardous voltages, disconnect all power cords.
- Connect all power cords to a properly wired and grounded electrical outlet. Ensure that the outlet supplies proper voltage and phase rotation according to the system rating plate.
- Connect any equipment that will be attached to this product to properly wired outlets.
- When possible, use one hand only to connect or disconnect signal cables.
- Never turn on any equipment when there is evidence of fire, water, or structural damage.
- Disconnect the attached power cords, telecommunications systems, networks, and modems before you open the device covers, unless instructed otherwise in the installation and configuration procedures.
- Connect and disconnect cables as described in the following procedures when installing, moving, or opening covers on this product or attached devices.

To Disconnect:

1. Turn off everything (unless instructed otherwise).
2. Remove the power cords from the outlets.
3. Remove the signal cables from the connectors.
4. Remove all cables from the devices.

To Connect:

1. Turn off everything (unless instructed otherwise).
2. Attach all cables to the devices.
3. Attach the signal cables to the connectors.
4. Attach the power cords to the outlets.
5. Turn on the devices.

(D005)

## DANGER



Observe the following precautions when working on or around your IT rack system:

- Heavy equipment—personal injury or equipment damage might result if mishandled.
- Always lower the leveling pads on the rack cabinet.
- Always install stabilizer brackets on the rack cabinet.
- To avoid hazardous conditions due to uneven mechanical loading, always install the heaviest devices in the bottom of the rack cabinet. Always install servers and optional devices starting from the bottom of the rack cabinet.
- Rack-mounted devices are not to be used as shelves or work spaces. Do not place objects on top of rack-mounted devices.



- Each rack cabinet might have more than one power cord. Be sure to disconnect all power cords in the rack cabinet when directed to disconnect power during servicing.
- Connect all devices installed in a rack cabinet to power devices installed in the same rack cabinet. Do not plug a power cord from a device installed in one rack cabinet into a power device installed in a different rack cabinet.
- An electrical outlet that is not correctly wired could place hazardous voltage on the metal parts of the system or the devices that attach to the system. It is the responsibility of the customer to ensure that the outlet is correctly wired and grounded to prevent an electrical shock.

#### CAUTION

- Do not install a unit in a rack where the internal rack ambient temperatures will exceed the manufacturer's recommended ambient temperature for all your rack-mounted devices.
- Do not install a unit in a rack where the air flow is compromised. Ensure that air flow is not blocked or reduced on any side, front, or back of a unit used for air flow through the unit.
- Consideration should be given to the connection of the equipment to the supply circuit so that overloading of the circuits does not compromise the supply wiring or overcurrent protection. To provide the correct power connection to a rack, refer to the rating labels located on the equipment in the rack to determine the total power requirement of the supply circuit.
- *(For sliding drawers.)* Do not pull out or install any drawer or feature if the rack stabilizer brackets are not attached to the rack. Do not pull out more than one drawer at a time. The rack might become unstable if you pull out more than one drawer at a time.
- *(For fixed drawers.)* This drawer is a fixed drawer and must not be moved for servicing unless specified by the manufacturer. Attempting to move the drawer partially or completely out of the rack might cause the rack to become unstable or cause the drawer to fall out of the rack.

(R001)

**CAUTION:**

Removing components from the upper positions in the rack cabinet improves rack stability during relocation. Follow these general guidelines whenever you relocate a populated rack cabinet within a room or building:

- Reduce the weight of the rack cabinet by removing equipment starting at the top of the rack cabinet. When possible, restore the rack cabinet to the configuration of the rack cabinet as you received it. If this configuration is not known, you must observe the following precautions:
  - Remove all devices in the 32U position and above.
  - Ensure that the heaviest devices are installed in the bottom of the rack cabinet.
  - Ensure that there are no empty U-levels between devices installed in the rack cabinet below the 32U level.
- If the rack cabinet you are relocating is part of a suite of rack cabinets, detach the rack cabinet from the suite.
- Inspect the route that you plan to take to eliminate potential hazards.
- Verify that the route that you choose can support the weight of the loaded rack cabinet. Refer to the documentation that comes with your rack cabinet for the weight of a loaded rack cabinet.
- Verify that all door openings are at least 760 x 230 mm (30 x 80 in.).
- Ensure that all devices, shelves, drawers, doors, and cables are secure.
- Ensure that the four leveling pads are raised to their highest position.
- Ensure that there is no stabilizer bracket installed on the rack cabinet during movement.
- Do not use a ramp inclined at more than 10 degrees.
- When the rack cabinet is in the new location, complete the following steps:
  - Lower the four leveling pads.
  - Install stabilizer brackets on the rack cabinet.
  - If you removed any devices from the rack cabinet, repopulate the rack cabinet from the lowest position to the highest position.
- If a long-distance relocation is required, restore the rack cabinet to the configuration of the rack cabinet as you received it. Pack the rack cabinet in the original packaging material, or equivalent. Also lower the leveling pads to raise the casters off of the pallet and bolt the rack cabinet to the pallet.

(R002)

(L001)



(L002)



(L003)

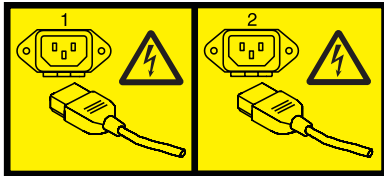

or



All lasers are certified in the U.S. to conform to the requirements of DHHS 21 CFR Subchapter J for class 1 laser products. Outside the U.S., they are certified to be in compliance with IEC 60825 as a class 1 laser product. Consult the label on each part for laser certification numbers and approval information.

**CAUTION:**

This product might contain one or more of the following devices: CD-ROM drive, DVD-ROM drive, DVD-RAM drive, or laser module, which are Class 1 laser products. Note the following information:

- Do not remove the covers. Removing the covers of the laser product could result in exposure to hazardous laser radiation. There are no serviceable parts inside the device.
- Use of the controls or adjustments or performance of procedures other than those specified herein might result in hazardous radiation exposure.

(C026)

**CAUTION:**

Data processing environments can contain equipment transmitting on system links with laser modules that operate at greater than Class 1 power levels. For this reason, never look into the end of an optical fiber cable or open receptacle. (C027)

**CAUTION:**

This product contains a Class 1M laser. Do not view directly with optical instruments. (C028)

**CAUTION:**

Some laser products contain an embedded Class 3A or Class 3B laser diode. Note the following information: laser radiation when open. Do not stare into the beam, do not view directly with optical instruments, and avoid direct exposure to the beam. (C030)

**CAUTION:**

The battery contains lithium. To avoid possible explosion, do not burn or charge the battery.

*Do Not:*

- \_\_\_ Throw or immerse into water
- \_\_\_ Heat to more than 100°C (212°F)
- \_\_\_ Repair or disassemble

Exchange only with the IBM-approved part. Recycle or discard the battery as instructed by local regulations. In the United States, IBM has a process for the collection of this battery. For information, call 1-800-426-4333. Have the IBM part number for the battery unit available when you call. (C003)

## **Power and cabling information for NEBS (Network Equipment-Building System) GR-1089-CORE**

The following comments apply to the IBM servers that have been designated as conforming to NEBS (Network Equipment-Building System) GR-1089-CORE:

The equipment is suitable for installation in the following:

- Network telecommunications facilities
- Locations where the NEC (National Electrical Code) applies

The intrabuilding ports of this equipment are suitable for connection to intrabuilding or unexposed wiring or cabling only. The intrabuilding ports of this equipment *must not* be metallically connected to the interfaces that connect to the OSP (outside plant) or its wiring. These interfaces are designed for use as intrabuilding interfaces only (Type 2 or Type 4 ports as described in GR-1089-CORE) and require isolation from the exposed OSP cabling. The addition of primary protectors is not sufficient protection to connect these interfaces metallically to OSP wiring.

**Note:** All Ethernet cables must be shielded and grounded at both ends.

The ac-powered system does not require the use of an external surge protection device (SPD).

The dc-powered system employs an isolated DC return (DC-I) design. The DC battery return terminal *shall not* be connected to the chassis or frame ground.

---

## **Vital product data card**

You can install, or remove and replace a vital product data (VPD) card.

The following procedures describe the removal and replacement of the vital product data card. Replacing this field-replaceable unit (FRU) must be completed by an authorized service representative.



---

## Removing and replacing the 8233-E8B or 8236-E8C vital product data card

Learn how to remove or replace the IBM Power® 750 Express (8233-E8B) or IBM Power 755 (8236-E8C) vital product data (VPD) card.

---

### Removing the 8233-E8B or 8236-E8C vital product data card

Learn how to remove the vital product data (VPD) card.

If your system is managed by the Hardware Management Console (HMC), use the HMC to remove a VPD card. For instructions, see *Removing a part by using the Hardware Management Console*.

If your system is managed by the IBM Systems Director Management Console (SDMC), use the SDMC to remove a VPD card. For instructions, see *Removing a part by using the Systems Director Management Console*.

**Note:** If you plan to replace the VPD card and have the replacement card, you can contact the following email address from 8 a.m. to 5 p.m. US Central Time, Monday to Friday, to obtain the replacement activation codes before repair. You must supply the machine type and serial number, and the part number and serial number of the replacement VPD card. If you use the AIX® or Linux operating systems, contact [pcod@us.ibm.com](mailto:pcod@us.ibm.com). If you use the IBM i operating system, contact [icod@us.ibm.com](mailto:icod@us.ibm.com).

If you do not have an HMC or SDMC, complete the following steps to remove the VPD card:

1. Complete the prerequisite tasks that are described in “Before you begin” on page 9.
2. Access the Advanced System Management Interface (ASMI).

The ASMI is the interface to the service processor that is required to perform general and administrator-level service tasks, such as reading service processor error logs, reading vital product data, setting up the service processor, and controlling the system power. The ASMI is also referred to as the service processor menus. To access the ASMI, see *Accessing the Advanced System Management Interface*. After you have accessed the ASMI, continue with the next step.

3. Save the system identifiers.
  - a. In the ASMI Welcome page, if you have not already logged in, specify your user ID and password, and click **Log in**.
  - b. In the navigation area, expand **System Configuration > Program Vital Product Data**.
  - c. Select **System Brand** under **Program Vital Product Data**.
  - d. Manually record the value for the system brand, which appears in the right pane.
  - e. In the navigation area, select **System Keywords** under **Program Vital Product Data**.
  - f. Manually record the Machine type-model, System serial number, System unique ID values. Also record the activation codes, if applicable, for the Capacity on Demand (COD) and Virtualization Engine Technologies (VET) values, which are shown in the content pane.

**Notes:**

- 1) If you do not know the system unique ID, contact your next level of support.
  - 2) You cannot boot the system until valid values are entered for all fields.
  - 3) You can change these entries only once.
  - g. Click **Save settings** to update the system keywords and save them to the VPD.
4. Turn on the blue system LED to identify the system you are working on. See *Enabling enclosure indicators*.

5. If necessary, identify the VPD card that you need to replace. See “Identifying a part” on page 11.
6. Shut down the partitions and power off the system.

This FRU cannot be serviced concurrently. Every partition must be shut down, and the system must be powered off to continue the repair. Authorization must come from the customer to shut down all running partitions and to power off the system. If the customer does not allow the partitions to be shut down or the system to be powered off, delay the service procedure. If the customer is using a secondary management console to manage the system, ensure that the customer is not powering on the system at this time.

7. Place the system into the service position as described in Placing the 8233-E8B or 8236-E8C system in the service position.
8. Remove the service access cover as described in Removing the service access cover from an 8233-E8B or 8236-E8C system.
9. Place the system back into the operating position. The system does not function with the cover removed. However, the system must be in the operating position to disconnect cables.
10. Disconnect the power cords as described in Removing or replacing the 8233-E8B or 8236-E8C power supplies.
11. Place the system into the service position as described in Placing the 8233-E8B or 8236-E8C system in the service position.
12. Attach the wrist strap.

**Attention:**

- Attach a wrist strap to an unpainted metal surface of your hardware to prevent electrostatic discharge (ESD) from damaging your hardware.
- When using a wrist strap, follow all electrical safety procedures. A wrist strap is for static control. It does not increase or decrease your risk of receiving electric shock when using or working on electrical equipment.
- If you do not have a wrist strap, just prior to removing the product from ESD packaging and installing or replacing hardware, touch an unpainted metal surface of the system for a minimum of 5 seconds.

13. Remove the VPD card:
  - a. Press on the handle **(A)** to unlock the VPD card **(B)** from its slot on the system backplane.
  - b. Pull the VPD card out of its slot.



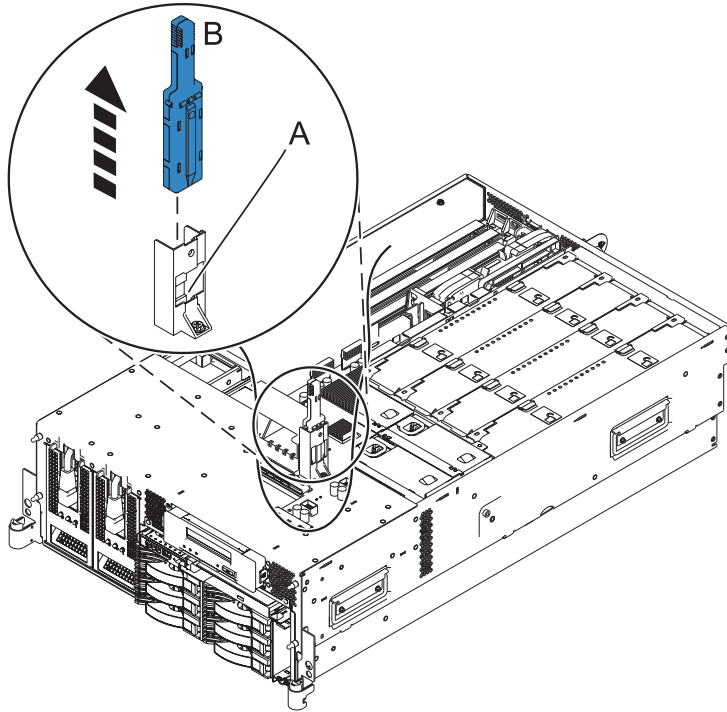

Figure 1. Remove the VPD card

---

## Installing the 8233-E8B or 8236-E8C vital product data card

Learn how to install the vital product data (VPD) card.

To complete this procedure, you must have already completed the removal procedure. For the removal procedure instructions, see “Removing the 8233-E8B or 8236-E8C vital product data card” on page 3.

If your system is managed by the Hardware Management Console (HMC), use the HMC to install a VPD card. For instructions, see Replacing a part by using the Hardware Management Console.

If your system is managed by the IBM Systems Director Management Console (SDMC), use the SDMC to install a VPD card. For instructions, see Replacing a part by using the Systems Director Management Console.

**Note:** If you plan to install the VPD card and have the replacement card, you can contact the following email address from 8 a.m. to 5 p.m. US Central Time, Monday to Friday, to obtain replacement activation codes prior to repair. You must supply the machine type and serial number, and the part number and serial number of the replacement VPD card. If you use the AIX or Linux operating systems, contact [pcod@us.ibm.com](mailto:pcod@us.ibm.com). If you use the IBM i operating system, contact [icod@us.ibm.com](mailto:icod@us.ibm.com).

If you do not have an HMC or SDMC, complete the following steps to install the VPD card:

**Attention:**

Attach a wrist strap to an unpainted metal surface of your hardware to prevent electrostatic discharge from damaging your hardware.

When using a wrist strap, follow all electrical safety procedures. A wrist strap is for static control. It does not increase or decrease your risk of receiving electric shock when using or working on electrical equipment.

If you do not have a wrist strap prior to removing the product from ESD packaging and installing or replacing hardware, touch an unpainted metal surface of the system for a minimum of 5 seconds.

1. Install the VPD card:
  - a. Press on the handle (A) to insert the VPD card (B) into its slot on the system backplane.
  - b. Push the VPD card into place until it is fully seated.

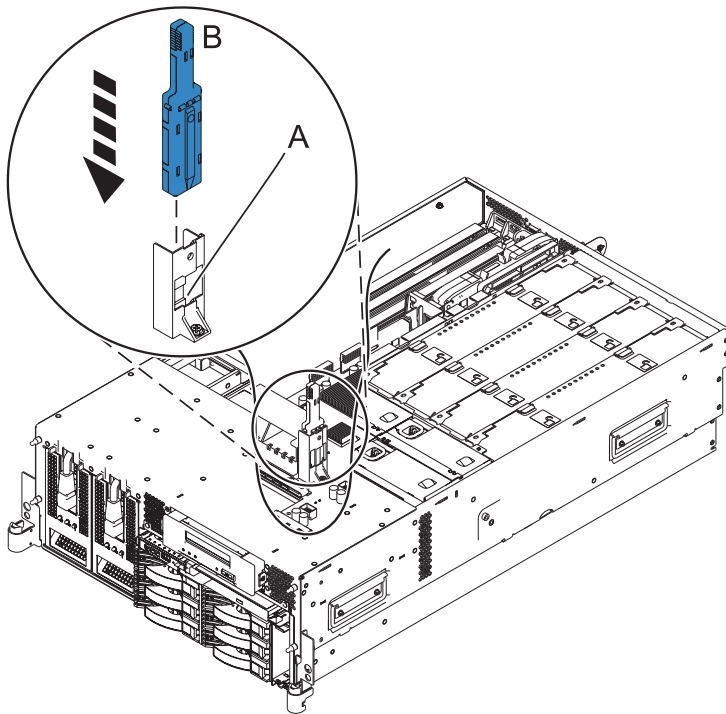

Figure 2. Install the VPD card

2. Install the service access cover as described in Installing the service access cover on an 8233-E8B or 8236-E8C system.
3. Place the system in the operating position as described in Placing the 8233-E8B or 8236-E8C system in the operating position.
4. Install the power cords as described in Removing or replacing the 8233-E8B or 8236-E8C power supplies.
5. When the service processor comes up to the standby state (the power-on LED on the control panel is flashing slowly), continue to the next step.
6. Access the ASMI.

If you are already connected to the ASMI, go to the next step.

  - To access the ASMI through the HMC, complete the following steps:
    - a. Select the server that you are working with.
    - b. Click **Tasks**.

- c. Click **Operations > Launch Advanced System Management (ASM)**.
- To access the ASMI through the SDMC, complete the following steps:
  - a. Select the server that you are working with.
  - b. Click **Actions > Operations > Launch Advanced System Management (ASM)**.
- 7. Set the system identifiers and the activation codes for the Capacity on Demand (CoD) and Virtualization Engine technologies:

**Note:** To perform this operation, your authority level must be administrator or authorized service provider.

- a. In the ASM Welcome pane, if you have not already logged in, specify your user ID and password, and click **Log In**.
- b. In the navigation area, expand **System Configuration > Program Vital Product Data**.
- c. Click **System Brand**.

**Note:** If you do not know the correct system brand, contact your next level of support.

- d. If the backed-up system brand is correct, click **Accept backed up setting** and save the settings. Otherwise, enter the correct system brand and click **Continue**.
- e. Click **Save setting** to update the system brand to the VPD.
- f. Click **System Keywords**.

**Note:** If you do not know the system unique ID, contact your next level of support. You cannot boot the system until valid values are entered for all fields. You can change these entries only once.

- g. If the backed-up system keywords are correct, click **Accept backed up setting** and save the settings. Otherwise, enter the values for the machine type, model number, system serial number, system unique ID and RB Keyword.
- h. Click **Save settings** to update the system keywords and to save them to the VPD.
- i. Update the field core override value if necessary. Ask the customer if they are overriding any processor cores, if so, see Field core override function overview.
- j. Start the system or logical partition. See Starting the system or logical partition.
- k. In the ASMI navigation panel, expand **On demand Utilities > CoD Activation**. Enter the CoD code and click **Continue** to write the CoD code to VPD.



---

## Common procedures for installable features

This section contains all the common procedures that are related to installing, removing, and replacing features.

---

### Before you begin

Observe these precautions when you are installing, removing, or replacing features and parts.

These precautions are intended to create a safe environment to service your system and do not provide steps for servicing your system. The installation, removal, and replacement procedures provide the step-by-step processes required to service your system.

#### DANGER

When working on or around the system, observe the following precautions:

Electrical voltage and current from power, telephone, and communication cables are hazardous. To avoid a shock hazard:

- Connect power to this unit only with the IBM provided power cord. Do not use the IBM provided power cord for any other product.
- Do not open or service any power supply assembly.
- Do not connect or disconnect any cables or perform installation, maintenance, or reconfiguration of this product during an electrical storm.
- The product might be equipped with multiple power cords. To remove all hazardous voltages, disconnect all power cords.
- Connect all power cords to a properly wired and grounded electrical outlet. Ensure that the outlet supplies proper voltage and phase rotation according to the system rating plate.
- Connect any equipment that will be attached to this product to properly wired outlets.
- When possible, use one hand only to connect or disconnect signal cables.
- Never turn on any equipment when there is evidence of fire, water, or structural damage.
- Disconnect the attached power cords, telecommunications systems, networks, and modems before you open the device covers, unless instructed otherwise in the installation and configuration procedures.
- Connect and disconnect cables as described in the following procedures when installing, moving, or opening covers on this product or attached devices.

**To Disconnect:**

1. Turn off everything (unless instructed otherwise).
2. Remove the power cords from the outlets.
3. Remove the signal cables from the connectors.
4. Remove all cables from the devices.

**To Connect:**

1. Turn off everything (unless instructed otherwise).
2. Attach all cables to the devices.
3. Attach the signal cables to the connectors.
4. Attach the power cords to the outlets.
5. Turn on the devices.

(D005)

#### DANGER

Observe the following precautions when working on or around your IT rack system:

- Heavy equipment—personal injury or equipment damage might result if mishandled.
- Always lower the leveling pads on the rack cabinet.
- Always install stabilizer brackets on the rack cabinet.
- To avoid hazardous conditions due to uneven mechanical loading, always install the heaviest devices in the bottom of the rack cabinet. Always install servers and optional devices starting from the bottom of the rack cabinet.
- Rack-mounted devices are not to be used as shelves or work spaces. Do not place objects on top of rack-mounted devices.



- Each rack cabinet might have more than one power cord. Be sure to disconnect all power cords in the rack cabinet when directed to disconnect power during servicing.
- Connect all devices installed in a rack cabinet to power devices installed in the same rack cabinet. Do not plug a power cord from a device installed in one rack cabinet into a power device installed in a different rack cabinet.
- An electrical outlet that is not correctly wired could place hazardous voltage on the metal parts of the system or the devices that attach to the system. It is the responsibility of the customer to ensure that the outlet is correctly wired and grounded to prevent an electrical shock.

#### CAUTION

- Do not install a unit in a rack where the internal rack ambient temperatures will exceed the manufacturer's recommended ambient temperature for all your rack-mounted devices.
- Do not install a unit in a rack where the air flow is compromised. Ensure that air flow is not blocked or reduced on any side, front, or back of a unit used for air flow through the unit.
- Consideration should be given to the connection of the equipment to the supply circuit so that overloading of the circuits does not compromise the supply wiring or overcurrent protection. To provide the correct power connection to a rack, refer to the rating labels located on the equipment in the rack to determine the total power requirement of the supply circuit.
- *(For sliding drawers.)* Do not pull out or install any drawer or feature if the rack stabilizer brackets are not attached to the rack. Do not pull out more than one drawer at a time. The rack might become unstable if you pull out more than one drawer at a time.
- *(For fixed drawers.)* This drawer is a fixed drawer and must not be moved for servicing unless specified by the manufacturer. Attempting to move the drawer partially or completely out of the rack might cause the rack to become unstable or cause the drawer to fall out of the rack.

(R001)

Before you begin a replacement or installation procedure, perform these tasks:

1. If you are installing a new feature, ensure that you have the software required to support the new feature. See IBM Prerequisite.
2. If you are performing an installation or replacement procedure that might put your data at risk, ensure, wherever possible, that you have a current backup of your system or logical partition (including operating systems, licensed programs, and data).
3. Review the installation or replacement procedure for the feature or part.
4. Note the significance of color on your system.

Blue or terra-cotta on a part of the hardware indicates a touch point where you can grip the hardware to remove it from or install it in the system, open or close a latch, and so on. Terra-cotta might also indicate that the part can be removed and replaced with the system or logical partition power on.

5. Ensure that you have access to a medium flat-blade screwdriver, a Phillips screwdriver, and a pair of scissors.
6. If parts are incorrect, missing, or visibly damaged, do the following:
  - If you are replacing a part, contact the provider of your parts or next level of support.
  - If you are installing a feature, contact one of the following service organizations:
    - The provider of your parts or next level of support.
    - In the United States, the IBM Rochester Manufacturing Automated Information Line (R-MAIL) at 1-800-300-8751.

In countries and regions outside of the United States, use the following website to locate your service and support telephone numbers:

<http://www.ibm.com/planetwide>

7. If you encounter difficulties during the installation, contact your service provider, your IBM reseller, or your next level of support.
8. If you are installing new hardware in a logical partition, you need to understand and plan for the implications of partitioning your system. For information, see Logical Partitioning.

---

## Identifying a part

Use these instructions to learn how to identify the location of a failed part, the location of a part to be removed, or the location to install a new part on your system or expansion unit using the appropriate method for your system.

For IBM Power Systems<sup>™</sup> servers that contain the POWER7<sup>®</sup> processor, the light-emitting diodes (LEDs) can be used to identify or verify the location of a part that you are removing, servicing, or installing.

The combination identify and fault LED (amber color) shows the location of a field replaceable unit (FRU). When removing a FRU, first verify whether you are working on the correct FRU by using the identify function in the management console or other user interface. When removing a FRU by using the hardware management console, the identify function is activated and deactivated automatically at the correct times.

The identify function causes the amber LED to flash. When you turn off the identify function, the LED returns to the state it was previously. For parts that have a blue service button, the identify function sets LED information for the service button so that when the button is pressed, the correct LEDs on that part flash.

If you need to use the identify function, use the following procedures.

## Control panel LEDs

Use this information as a guide to the control panel LEDs and buttons.

The control panel has LEDs that indicate various system status.

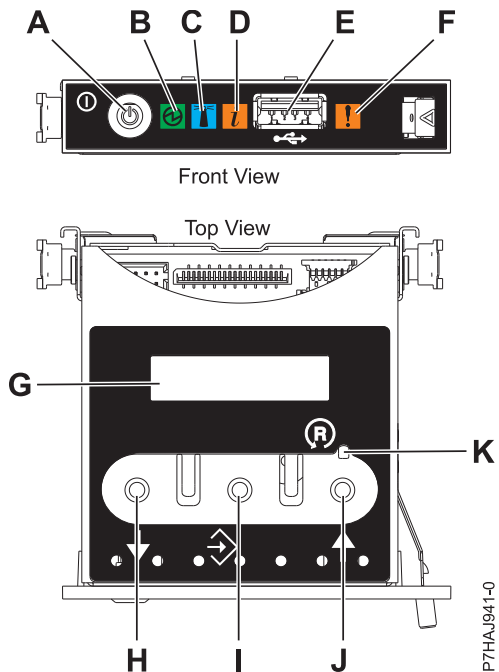

Figure 3. Control panel

- **A:** Power-on button
- **B:** Power LED
  - A constant light indicates full system power to the unit.
  - A flashing light indicates standby power to the unit.

**Note:** There is approximately a 30-second transition period from the time the power-on button is pressed to when the power LED goes from flashing to solid. During the transition period, the LED might flash faster.

- **C:** Enclosure identify light
  - A constant light indicates the identify state, which is used to identify a part.
  - No light indicates that the system is operating normally.
- **D:** System information light
  - No light indicates that the system is operating normally.
  - Light on indicates that the system requires attention.
- **E:** USB port
- **F:** Enclosure fault roll-up light
  - A constant light indicates a fault in the system unit.
  - No light indicates that the system is operating normally.
- **G:** Function/Data display
- **H:** Decrement button
- **I:** Enter button
- **J:** Increment button
- **K:** Pinhole reset button

**Related concepts:**

Identifying a failing part

Use these instructions to learn how to locate and identify a failing part on your system or expansion unit using the appropriate method for your system.



## Identifying a failing part in an AIX system or logical partition

Use these instructions to learn how to locate a failing part, and then activate the indicator light for that part on a system or logical partition running the AIX operating system.

### Locating a failing part in an AIX system or logical partition

You might need to use AIX tools, before activating the indicator light, to locate a part that is failing.

1. Log in as root user or celogin-.
2. At the command line, type `diag` and press Enter.
3. From the Function Selection menu, select **Task Selection** and press Enter.
4. Select **Display Previous Diagnostic Results** and press Enter.
5. From the Display Previous Diagnostic Results display, select **Display Diagnostic Log Summary**. The Display Diagnostic Log display shows a chronological list of events.
6. Look in the **T** column for the most recent **S** entry. Select this row in the table and press Enter.
7. Select **Commit**. The details of this log entry are shown.
8. Record the location information and the SRN value shown near the end of the entry.
9. Exit to the command line.

Use the location information for the failing part to activate the indicator light that identifies the failing part. See “Activating the indicator light for the failing part.”

### Activating the indicator light for the failing part

Use these instructions to help physically identify the location of a part you are servicing.

To activate the indicator light for a failing part, complete the following steps:

1. Log in as root user.
2. At the command line, type `diag` and press Enter.
3. From the **Function Selection** menu, select **Task Selection** and press Enter.
4. From the **Task Selection** menu, select **Identify and Attention Indicators** and press Enter.
5. From the list of lights, select the location code for the failing part and press Enter.
6. Select **Commit**. This turns on the system attention and indicator light for the failing part.
7. Exit to the command line.

### Deactivating the failing-part indicator light

Use this procedure to turn off any indicator light that you turned on as a part of a service action.

To deactivate the indicator light, complete the following steps:

1. Log in as root user.
2. At the command line, type `diag` and press Enter.
3. From the **Function Selection** menu, select **Task Selection** and press Enter.
4. From the **Task Selection** menu, select **Identify and Attention Indicators** and press Enter.
5. From the list of lights, select the location code for the failing part and press Enter. When a light is activated for a failing part, an I character precedes the location code.
6. Select **Commit**. This turns off the system attention and indicator light for the failing part.
7. Exit to the command line.

## Identifying a failing part in an IBM i system or logical partition

You can activate or deactivate the indicator light by using IBM i to assist in locating a failing part.

## Activating the failing-part indicator light

You can search the service action log for an entry that matches the time, reference code, or resource of a problem, and then activate the indicator light for a failing part.

1. Sign on to an IBM i session, **with at least service level authority**.
2. On the command line of the session, type `strsst` and press Enter.

**Note:** If you cannot get to the System Service Tools display, use function 21 from the control panel. Alternatively, if the system is managed by a Hardware Management Console (HMC), use the Service Focal Point utilities to get to the Dedicated Service Tools (DST) display.

3. Type your service tools user ID and service tools password on the System Service Tools (SST) Sign On display and press Enter.

**Remember:** The service tools password is case-sensitive.

4. Select **Start a service tool** from the System Service Tools (SST) display and press Enter.
5. Select **Hardware service manager** from the Start a Service Tool display and press Enter.
6. Select **Work with service action log** from the Hardware Service Manager display and press Enter.
7. On the Select Timeframe display, change the **From: Date and Time** field to a date and time prior to when the problem occurred.
8. Search for an entry that matches one or more conditions of the problem:
  - System reference code
  - Resource
  - Date and time
  - Failing item list
9. Select option 2 (Display failing item information) to display the service action log entry.
10. Select option 2 (Display details) to display location information for the failing part to be replaced. The information displayed in the date and time fields is the date and time for the first occurrence of the specific system reference code for the resource displayed during the time range selected.
11. If location information is available, select option 6 (Indicator on) to turn on the failing part's indicator light.

**Tip:** If the failing part does not contain a physical indicator light, a higher-level indicator light is activated. For example, the indicator light for the backplane or unit that contains the failing part might be lit. In this case, use the location information to locate the actual failing part.

12. Look for the enclosure indicator light to locate the enclosure that contains the failing part.

## Deactivating the failing-part indicator light

Use this procedure to turn off any indicator light that you turned on as a part of a service action.

To deactivate the indicator light, follow these steps:

1. Sign on to an IBM i session, **with at least service level authority**.
2. On the command line of the session, type `strsst` and press Enter.

**Note:** If you cannot get to the System Service Tools display, use function 21 from the control panel. Alternatively, if the system is managed by a Hardware Management Console (HMC), use the Service Focal Point utilities to get to the Dedicated Service Tools (DST) display.

3. Type your service tools user ID and service tools password on the System Service Tools (SST) Sign On display and press Enter.

**Remember:** The service tools password is case-sensitive.

4. Select **Start a service tool** from the System Service Tools (SST) display and press Enter.
5. Select **Hardware service manager** from the Start a Service Tool display and press Enter.

6. Select **Work with service action log** from the Hardware Service Manager display and press Enter.
7. On the Select Timeframe display, change the **From: Date and Time** field to a date and time prior to when the problem occurred.
8. Search for an entry that matches one or more conditions of the problem:
  - System reference code
  - Resource
  - Date and time
  - Failing item list
9. Select option 2 (Display failing item information) to display the service action log entry.
10. Select option 2 (Display details) to display location information for the failing part to be replaced. The information displayed in the date and time fields is the date and time for the first occurrence of the specific system reference code for the resource displayed during the time range selected.
11. Select option 7 (Indicator off) to turn off the indicator light.
12. Select the **Acknowledge all errors** function at the bottom of the Service Action Log display, if all problems have been resolved.
13. Close the log entry by selecting option 8 (Close new entry) on the Service Action Log Report display.

## Identifying a failing part in a Linux system or logical partition

If the service aids have been installed on a system or logical partition, you can activate or deactivate the indicator lights to locate a part or complete a service action.

### Locating a failing part in a Linux system or logical partition

If the service aids have been installed on a system or logical partition, you need to activate the indicator lights to locate a part.

To activate the indicator light, follow these steps:

1. Log in as root user.
2. At the command line, type `/usr/sbin/usysident -s identify -l location_code` and press Enter.
3. Look for the system attention light to identify the enclosure that contains the failing part.

#### Related information:

 Service and productivity tools for PowerLinux servers from IBM

IBM provides hardware diagnostic aids and productivity tools, and installation aids for Linux operating systems on IBM Power Systems servers.

### Finding the location code of a failing part in a Linux system or logical partition

To retrieve the location code of the failing part, if you do not know the location code, use the procedure in this topic.

To locate the failing part in a system or logical partition, follow these steps:

1. Log in as root user.
2. At the command line, type `grep diagela /var/log/platform` and press Enter.
3. Look for the most recent entry that contains a system reference code (SRC).
4. Record the location information.

#### Related information:

 Service and productivity tools for PowerLinux servers from IBM

IBM provides hardware diagnostic aids and productivity tools, and installation aids for Linux operating systems on IBM Power Systems servers.

## Activating the indicator light for the failing part

If you know the location code of the failing part, activate the indicator light to help you locate which part to replace.

To activate the indicator light, follow these steps:

1. Log in as root user.
2. At the command line, type `/usr/sbin/usysident -s identify -l location_code` and press Enter.
3. Look for the system attention light to identify the enclosure that contains the failing part.

### Related information:

 Service and productivity tools for PowerLinux servers from IBM

IBM provides hardware diagnostic aids and productivity tools, and installation aids for Linux operating systems on IBM Power Systems servers.

## Deactivating the failing-part indicator light

After you complete a removal and replacement procedure, you must deactivate the failing-part indicator light.

To deactivate the indicator light, follow these steps:

1. Log in as root user.
2. At the command line, type `/usr/sbin/usysident -s normal -l location_code` and press Enter.

### Related information:

 Service and productivity tools for PowerLinux servers from IBM

IBM provides hardware diagnostic aids and productivity tools, and installation aids for Linux operating systems on IBM Power Systems servers.

## Locating a failing part in a Virtual I/O Server system or logical partition

You can use Virtual I/O Server (VIOS) tools, before activating the indicator light, to locate a part that is failing.

To locate the failing part, follow these steps:

1. Log in as root user or `celogin-`.
2. At the command line, type `diagmenu` and press Enter.
3. From the **Function Selection** menu, select **Task Selection** and press Enter.
4. Select **Display Previous Diagnostic Results** and press Enter.
5. From the **Display Previous Diagnostic Results** display, select **Display Diagnostic Log Summary**. A **Display Diagnostic Log** display appears. This display contains a chronological list of events.
6. Look in the **T** column for the most recent **S** entry. Select this row in the table and press Enter.
7. Choose **Commit**. The details of this log entry are shown.
8. Record the location information and the SRN value shown near the end of the entry.
9. Exit to the command line.

Use the location information for the failing part to activate the indicator light that identifies the failing part. For instructions, see “Identifying a part by using the Virtual I/O Server.”

## Identifying a part by using the Virtual I/O Server

You can use Virtual I/O Server (VIOS) tools to physically locate a part.

To turn on the indicator light for identifying a part, follow these steps:

1. Log in as root user.
2. At the command line, type `diagmenu` and press Enter.

3. From the **Function Selection** menu, select **Task Selection** and press Enter.
4. From the **Task Selection** menu, select **Identify and Attention Indicators** and press Enter.
5. From the list of lights, select the location code for the failing part and press Enter.
6. Select **Commit**. This turns on the system attention and indicator light for the failing part.
7. Exit to the command line.

---

## Starting the system or logical partition

Learn how to start a system or logical partition after performing a service action or system upgrade.

### Starting a system that is not managed by an HMC or an SDMC

You can use the power button or the Advanced System Management Interface (ASMI) to start a system that is not managed by a Hardware Management Console (HMC) or an IBM Systems Director Management Console (SDMC).

To start a system that is not managed by a HMC or SDMC, follow these steps:

1. Open the front rack door, if necessary.
2. Before you press the power button on the control panel, ensure that power is connected to the system unit as follows:
  - All system power cables are connected to a power source.
  - The power LED, as shown in the following figure, is slowly flashing.
  - The top of the display, as shown in the following figure, shows 01 V=F.
3. Press the power button (**A**), as shown in the following figure, on the control panel.

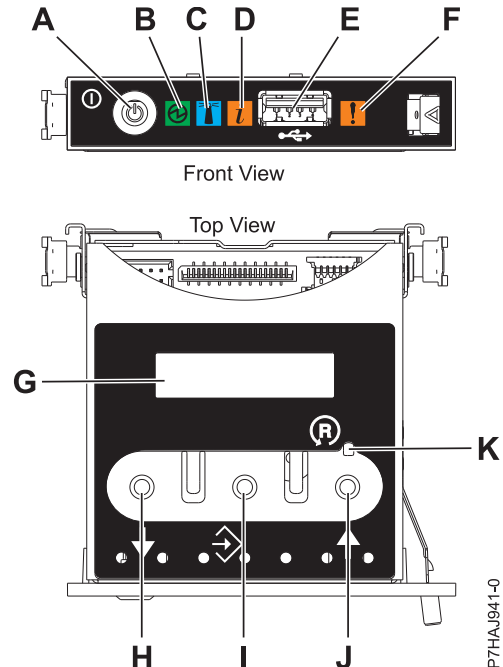

Figure 4. Control panel

- **A:** Power-on button
- **B:** Power LED
  - A constant light indicates full system power to the unit.
  - A flashing light indicates standby power to the unit.

**Note:** There is approximately a 30-second transition period from the time the power-on button is pressed to when the power LED goes from flashing to solid. During the transition period, the LED might flash faster.

- **C:** Enclosure identify light
    - A constant light indicates the identify state for the enclosure or for a resource within the enclosure.
    - No light indicates that no resources in the enclosure are being identified.
  - **D:** Attention light
    - No light indicates that the system is operating normally.
    - A solid light indicates that the system requires attention.
  - **E:** USB port
  - **F:** Enclosure fault roll-up light
    - A constant light indicates a fault indicator active in the system.
    - No light indicates that the system is operating normally.
  - **G:** Function/Data display
  - **H:** Decrement button
  - **I:** Enter button
  - **J:** Increment button
  - **K:** Pinhole reset button
4. Observe the following aspects after pressing the power button:
- The power-on light begins to flash faster.
  - The system cooling fans are activated after approximately 30 seconds and begin to accelerate to operating speed.
  - Progress indicators, also referred to as checkpoints, appear on the control panel display while the system is being started. The power-on light on the control panel stops flashing and remains on, indicating that the system power is on.

**Tip:** If pressing the power button does not start the system, do the following steps to start the system by using the Advanced System Management Interface (ASMI):

1. Access the ASMI. For instructions, see *Accessing the ASMI without an HMC*.
2. Start the system by using the ASMI. For instructions, see *Powering the system on and off*.

## Starting a system or logical partition by using the HMC

You can use the Hardware Management Console (HMC) to start the system or logical partition after the required cables are installed and the power cables are connected to a power source.

For instructions on working with the HMC, see *Managing the Hardware Management Console*. For instructions on starting a logical partition, see *Logical partitioning*. For instructions on starting the system, see *Powering on the managed system*.

Progress indicators, also referred to as checkpoints, appear on the control panel display while the system is being started. When the power-on light on the control panel stops blinking and remains on, the system power is on.

## Starting a system or virtual server by using the SDMC

You can use the IBM Systems Director Management Console (SDMC) to start the system or virtual server after the required cables are installed and the power cables are connected to a power source.

For instructions on working with the SDMC, see Managing and configuring the SDMC. For instructions on starting a virtual server, see Managing virtual servers. For instructions on shutting down and restarting virtual servers, see Shutting down and restarting virtual servers.

Progress indicators, also known as checkpoints, display on the control panel while the system is being started. When the power-on light on the control panel stops flashing and remains on, the system power is on.

---

## Stopping a system or logical partition

Learn how to stop a system or logical partition as a part of a system upgrade or service action.

**Attention:** Using either the power-on button on the control panel or entering commands at the Hardware Management Console (HMC) to stop the system can cause unpredictable results in the data files. Also, the next time you start the system, it might take longer if all applications are not ended before stopping the system.

To stop the system or logical partition, select the appropriate procedure.

## Stopping a system that is not managed by an HMC or an SDMC

You might need to stop the system to perform another task. If your system is not managed by the Hardware Management Console (HMC) or the IBM Systems Director Management Console (SDMC), use these instructions to stop the system by using the power button or the Advanced System Management Interface (ASMI).

Before you stop the system, follow these steps:

1. If an Integrated xSeries Adapter (IXA) is present on the system, shut it down using IBM i options.
2. Ensure that all jobs are completed and end all applications.
3. Ensure that the operating system is stopped.  
**Attention:** Failure to do so can result in the loss of data.
4. If a Virtual I/O Server (VIOS) logical partition is running, ensure that all clients are shut down or that the clients have access to their devices by using an alternate method.

The following procedure describes how to stop a system that is not managed by the HMC or the SDMC.

1. Log in to the system as a user with the authority to run the **shutdown** or **pwrdownsys** (Power Down System) command.
2. At the command line, enter one of the following commands:
  - If your system is running the AIX operating system, type **shutdown**.
  - If your system is running the Linux operating system, type **shutdown -h now**.
  - If your system is running the IBM i operating system, type **PWRDWN SYS**. If your system is partitioned, use the **PWRDWN SYS** command to power down each of the secondary partitions. Then, use the **PWRDWN SYS** command to power down the primary partition.

The command stops the operating system. The system power turns off, the power-on light begins to slowly flash, and the system goes into a standby state.

3. At the Linux command line, type **shutdown -h now**.  
The command stops the operating system. The system power turns off, the power-on light begins to slowly flash, and the system goes into a standby state.
4. Record the IPL type and the IPL mode from the control panel display to help you return the system to this state when the installation or replacement procedure is completed.
5. Set the power switches of any devices connected to the system to off.

6. Unplug any power cables that are attached to the peripheral devices, such as printers and expansion units.

**Important:** The system may be equipped with a second power supply. Before continuing with this procedure, ensure that all power sources to the system have been disconnected.

(L003)

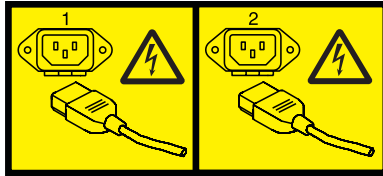

or



## Stopping a system by using the HMC

You can use the Hardware Management Console (HMC) to stop the system or a logical partition.

By default, the managed system is set to power off automatically when you shut down the last running logical partition on the managed system. If you set the managed system properties on the HMC so that the managed system does not power off automatically, you must use this procedure to power off your managed system.

**Attention:** If possible, shut down the running logical partitions on the managed system before powering off the managed system. Powering off the managed system without shutting down the logical partitions first causes the logical partitions to shut down abnormally and can cause data loss. If you use a Virtual I/O Server (VIOS) logical partition, ensure that all clients are shut down or that the clients have access to their devices using an alternate method.

To power off a managed system, you must be a member of one of the following roles:

- Super administrator
- Service representative
- Operator
- Product engineer



Use the following steps to stop the system by using the HMC:

1. In the navigation area, expand the **Systems Management** folder.
2. Click the **Servers** icon.
3. In the Contents area, select the managed system.
4. Select **Tasks > Operations > Power Off**.
5. Select the appropriate power-off mode and click **OK**.

**Related information:**

Shutting down and restarting logical partitions

## Stopping a system by using the SDMC

You can use the IBM Systems Director Management Console (SDMC) to stop the system or a virtual server.

By default, the managed system is set to power off automatically when you shut down the last running virtual server on the managed system. If you set the managed system properties on the SDMC so that the managed system does not power off automatically, you must use this procedure to power off your managed system.

**Attention:** If possible, shut down the running virtual servers on the managed system before powering off the managed system. Powering off the managed system without shutting down the virtual servers first causes the virtual servers to shut down abnormally and can cause data loss. If you use a Virtual I/O Server (VIOS) logical partition, ensure that all clients are shut down or that the clients have access to their devices with an alternate method.

To power off a managed system, you must be a member of one of the following roles:

- Super administrator
- Service representative
- Operator
- Product engineer

Use the following steps to stop the system by using the SDMC.

1. In the Power Systems Resource area, select the managed system you want to power off.
2. From the **Actions** menu, select **Operations > Power Off**.
3. Select the appropriate power-off mode and click **OK**.

---

## Enabling enclosure indicators

Find out how to display and change Field Replaceable Unit (FRU) indicators within each enclosure.

You can turn on or off the *identify* indicators in each enclosure. An *enclosure* is a group of indicators. For example, a processing unit enclosure represents all of the indicators within the processing unit and an I/O enclosure represents all of the indicators within that I/O enclosure. Enclosures are listed by their location code.

To perform this operation, you must have one of the following authority levels:

- Administrator
- Authorized service provider

To enable the enclosure indicator states, do the following steps:

1. On the ASMI Welcome pane, specify your user ID and password, and click **Log In**.
2. In the navigation area, expand **System Configuration** and **Service Indicators**.

3. Select **Enclosure Indicators**.
4. Select the enclosure of choice and click **Continue**.
5. Make the necessary changes to the selection list located next to each location code.
6. To save the changes made to the state of one or more FRU indicators, click **Save settings**.  
To turn off all of the indicators for this enclosure, click **Turn off all**. A report page is displayed indicating success or failure.

---

## Removing and replacing covers for the 8233-E8B or 8236-E8C system

Use these instructions to remove, replace, or install covers so that you can access the hardware parts or perform service.

### Removing the front cover from an 8233-E8B or 8236-E8C system

Use this procedure to remove the cover to access components or perform service.

To remove the front cover, follow these steps:

1. Remove the two screws (**A**) that secure the system to the rack (**B**) as shown in the following figure.
2. Pull the cover away from the system. The cover has an indentation where you can hold onto it more easily.

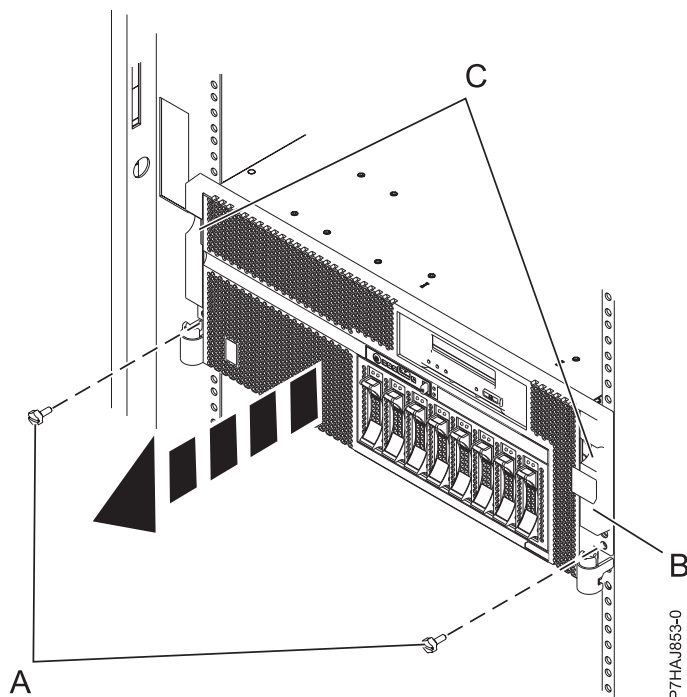

Figure 5. Removing the front cover

### Installing the front cover on an 8233-E8B or 8236-E8C system

Use this procedure to install the cover after accessing components or performing service.

To install the front cover, follow these steps:

1. Align the cover with the system.
2. Gently push the cover in until the four cover clips are seated in their respective mounting posts (**B**) on the system.

3. Replace the two screws (C) that secure the system to the rack (A).

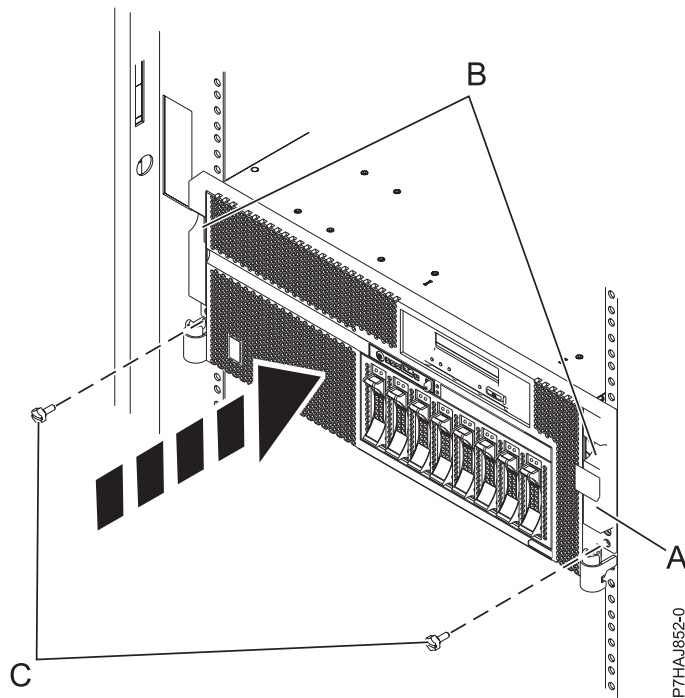

Figure 6. Installing the front cover

## Removing the service access cover from an 8233-E8B or 8236-E8C system

Use this procedure to remove the service access cover to perform service or to gain access to internal components.

To remove the service access cover, follow these steps:

1. Place the system into the service position. For instructions, see Placing the 8233-E8B or 8236-E8C in the service position.
2. Loosen the two thumbscrews (A) located at the rear of the cover.
3. Slide the cover (B) toward the rear of the system unit. When the front of the service access cover clears the upper frame ledge, lift the cover up and off the system unit.

**Attention:** For proper cooling and airflow, install the cover before starting the system. Operating the system without the cover for more than 30 minutes could damage the system components.

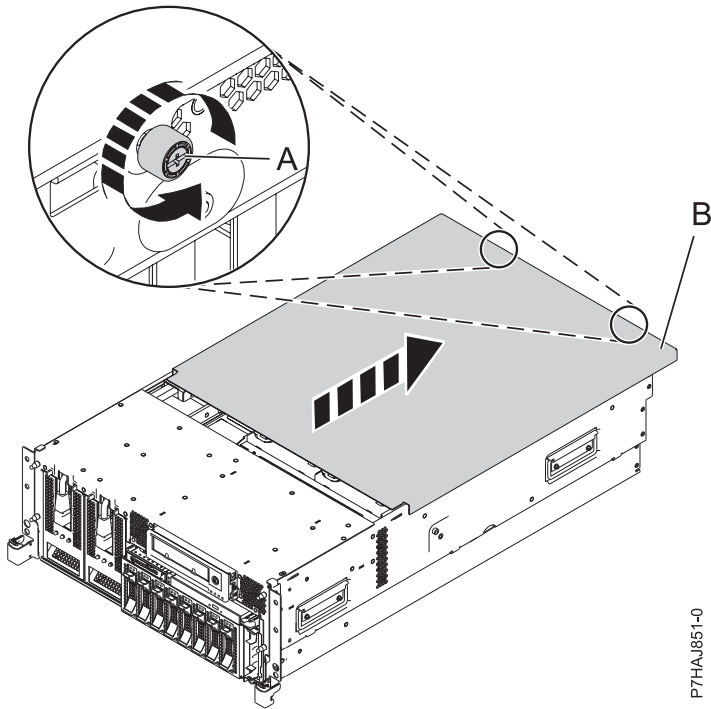

P7HAJ851-0

Figure 7. Removing the service access cover

**Related tasks:**

“Placing the 8233-E8B or 8236-E8C in the service position” on page 25

Use this procedure to perform service or gain access to internal components by placing the rack-mounted system or expansion unit in the service position.

**Installing the service access cover on an 8233-E8B or 8236-E8C system**

Use this procedure to install the service access cover after performing service or accessing internal components.

To install the service access cover, follow these steps:

1. Place the service access cover (A) on the top of the system unit, approximately 25 mm (1 in.) from the front of the system unit.
2. Hold the service access cover against the system unit, and slide it toward the front of the system. The tabs on the service access cover slide beneath the upper chassis ledge, and the two screws align with the screw holes at the rear of the system unit.

**Important:** Ensure that the fan LED cables do not get caught on the front edge of the service access cover as you move it forward.

3. Tighten the screws (B) located at the rear of the cover.

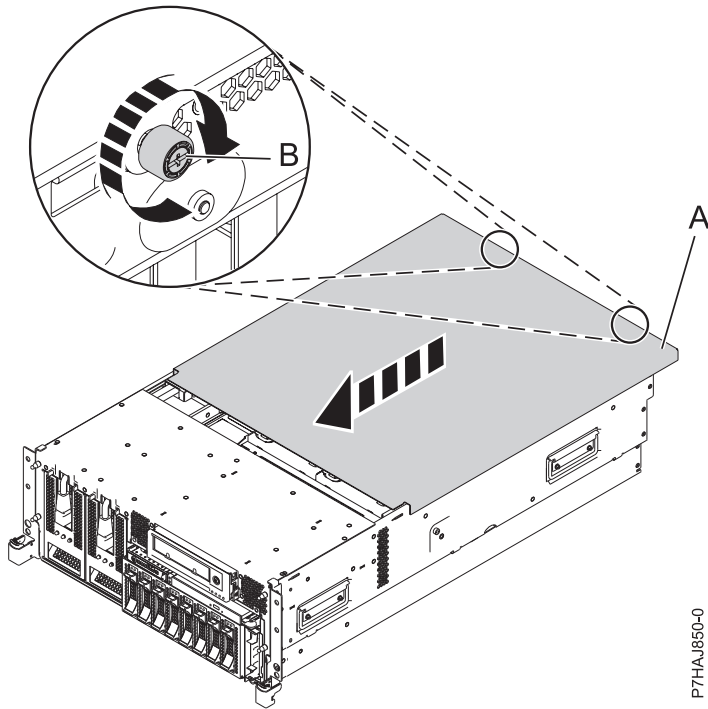

P7HAJ850-0

Figure 8. Installing the service access cover

---

## Placing the rack-mounted 8233-E8B or 8236-E8C system into the service position or operating position

Use these procedures to place a system into the service position or operating position to perform service or to gain access to internal components.

### Placing the 8233-E8B or 8236-E8C in the service position

Use this procedure to perform service or gain access to internal components by placing the rack-mounted system or expansion unit in the service position.

**Note:** Some of the figures in these procedures might not look exactly like the system or expansion unit that you have. However, the steps to perform the task are the same.

## DANGER

When working on or around the system, observe the following precautions:

Electrical voltage and current from power, telephone, and communication cables are hazardous. To avoid a shock hazard:

- Connect power to this unit only with the IBM provided power cord. Do not use the IBM provided power cord for any other product.
- Do not open or service any power supply assembly.
- Do not connect or disconnect any cables or perform installation, maintenance, or reconfiguration of this product during an electrical storm.
- The product might be equipped with multiple power cords. To remove all hazardous voltages, disconnect all power cords.
- Connect all power cords to a properly wired and grounded electrical outlet. Ensure that the outlet supplies proper voltage and phase rotation according to the system rating plate.
- Connect any equipment that will be attached to this product to properly wired outlets.
- When possible, use one hand only to connect or disconnect signal cables.
- Never turn on any equipment when there is evidence of fire, water, or structural damage.
- Disconnect the attached power cords, telecommunications systems, networks, and modems before you open the device covers, unless instructed otherwise in the installation and configuration procedures.
- Connect and disconnect cables as described in the following procedures when installing, moving, or opening covers on this product or attached devices.

To Disconnect:

1. Turn off everything (unless instructed otherwise).
2. Remove the power cords from the outlets.
3. Remove the signal cables from the connectors.
4. Remove all cables from the devices.

To Connect:

1. Turn off everything (unless instructed otherwise).
2. Attach all cables to the devices.
3. Attach the signal cables to the connectors.
4. Attach the power cords to the outlets.
5. Turn on the devices.

(D005)

## DANGER

Observe the following precautions when working on or around your IT rack system:

- Heavy equipment—personal injury or equipment damage might result if mishandled.
- Always lower the leveling pads on the rack cabinet.
- Always install stabilizer brackets on the rack cabinet.
- To avoid hazardous conditions due to uneven mechanical loading, always install the heaviest devices in the bottom of the rack cabinet. Always install servers and optional devices starting from the bottom of the rack cabinet.
- Rack-mounted devices are not to be used as shelves or work spaces. Do not place objects on top of rack-mounted devices.



- Each rack cabinet might have more than one power cord. Be sure to disconnect all power cords in the rack cabinet when directed to disconnect power during servicing.
- Connect all devices installed in a rack cabinet to power devices installed in the same rack cabinet. Do not plug a power cord from a device installed in one rack cabinet into a power device installed in a different rack cabinet.
- An electrical outlet that is not correctly wired could place hazardous voltage on the metal parts of the system or the devices that attach to the system. It is the responsibility of the customer to ensure that the outlet is correctly wired and grounded to prevent an electrical shock.

#### CAUTION

- Do not install a unit in a rack where the internal rack ambient temperatures will exceed the manufacturer's recommended ambient temperature for all your rack-mounted devices.
- Do not install a unit in a rack where the air flow is compromised. Ensure that air flow is not blocked or reduced on any side, front, or back of a unit used for air flow through the unit.
- Consideration should be given to the connection of the equipment to the supply circuit so that overloading of the circuits does not compromise the supply wiring or overcurrent protection. To provide the correct power connection to a rack, refer to the rating labels located on the equipment in the rack to determine the total power requirement of the supply circuit.
- *(For sliding drawers.)* Do not pull out or install any drawer or feature if the rack stabilizer brackets are not attached to the rack. Do not pull out more than one drawer at a time. The rack might become unstable if you pull out more than one drawer at a time.
- *(For fixed drawers.)* This drawer is a fixed drawer and must not be moved for servicing unless specified by the manufacturer. Attempting to move the drawer partially or completely out of the rack might cause the rack to become unstable or cause the drawer to fall out of the rack.

(R001)

To place the rack-mounted system or expansion unit into the service position, follow these steps:

1. If necessary, open the front rack door.
2. Remove the two screws **(A)** that secure the system unit to the rack as shown in the following figure.
3. Release the rack latches **(B)** on both the left and right sides as shown in the following figure.

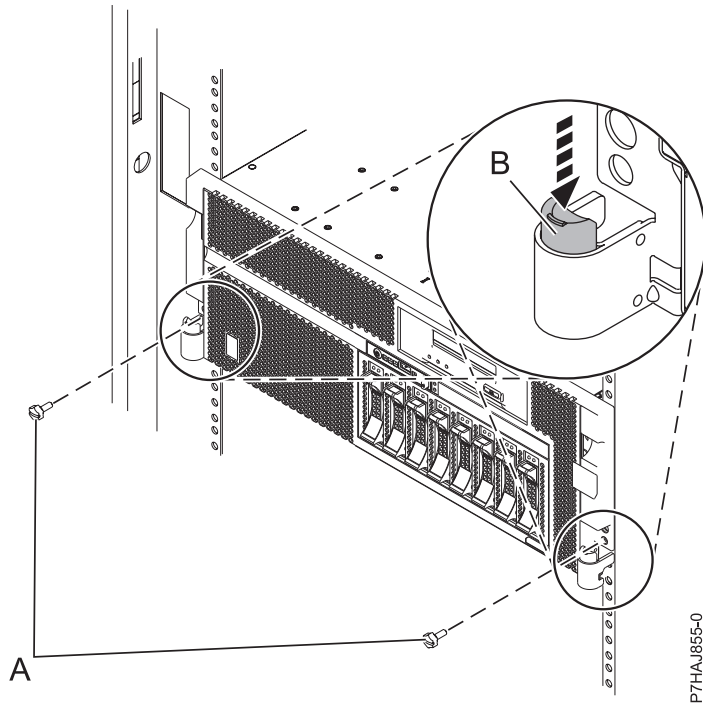

Figure 9. Releasing the rack latches

4. If required, unplug the cables from the rear of the system or expansion unit before you pull the unit out from the rack. Ensure that the cables at the rear of the system or expansion unit do not catch or bind as you pull the unit out from the rack.
5. Slowly pull the system or expansion unit out from the rack until the rails are fully extended and locked. Ensure that the rails are fully extended. When the rails are fully extended, the rail safety latches lock into place. This action prevents the system or expansion unit from being pulled out too far.

## Placing the 8233-E8B or 8236-E8C in the operating position

Use this procedure to place the system or expansion unit in the operating position to make the unit available for use.

To place the system into the operating position follow these steps:

**Tip:** Some of the figures in these procedures might not look exactly like the system or expansion unit that you have. However, the steps to perform the task are the same.

1. Simultaneously release the blue rail safety latches (**B**), located near the front of each rail, and push the system or expansion unit into the rack as shown in the following figure.

**Note:** Ensure that the cables at the rear of the system or expansion unit do not catch or bind as you push the unit back into the rack.



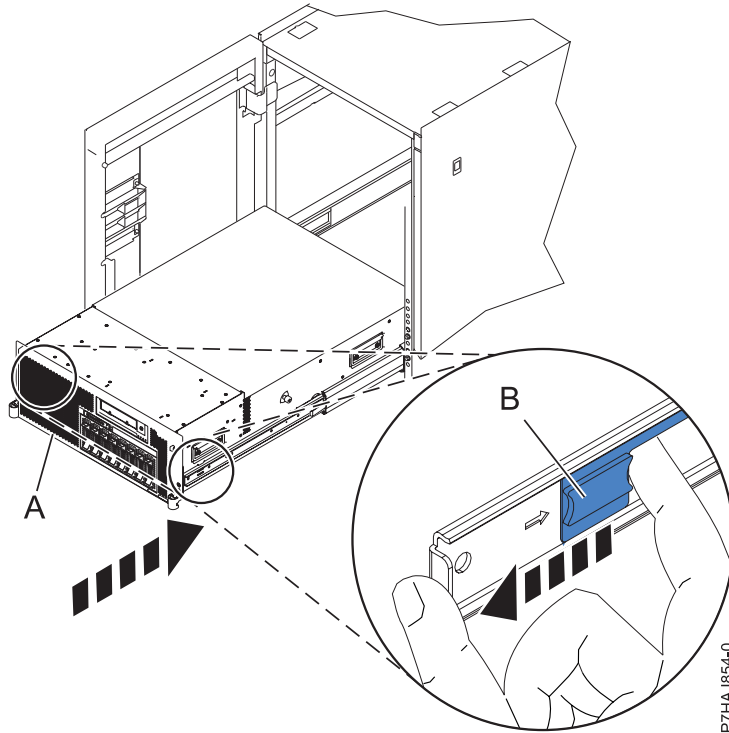

Figure 10. Releasing the rail safety latches

2. Replace and tighten the two thumbscrews (C) that secure the system or expansion unit (A) to the rack as shown in the following figure.

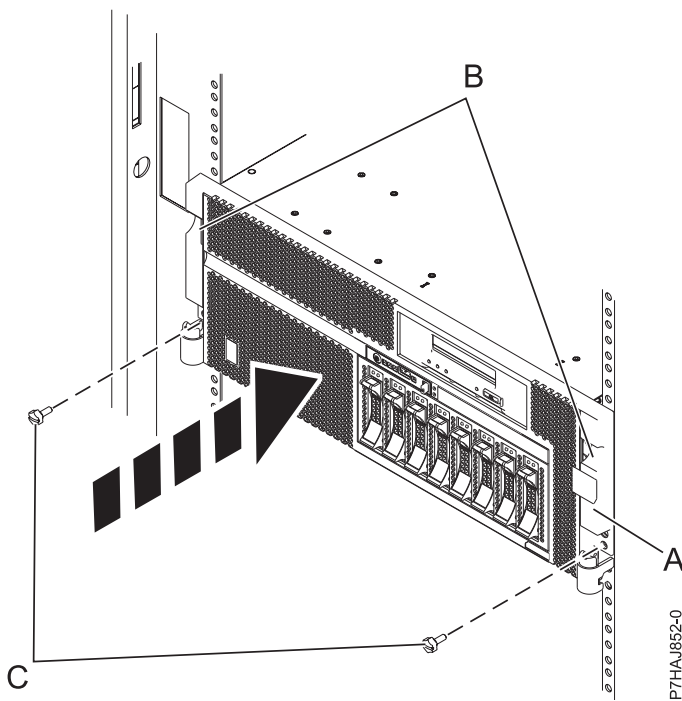

Figure 11. Replacing the thumbscrews

3. Close the front rack door.

---

## Removing a part by using the HMC

You can use the Hardware Management Console (HMC) to perform many service actions, including the removal of a field replaceable unit (FRU) or part.

To remove a part in a system or expansion unit that is managed by HMC Version 7, or later, complete the following steps:

1. In the navigation area, expand **Systems Management > Servers**.
2. Select the managed system from which you are removing a part.
3. In the **Tasks** area, expand **Serviceability > Hardware > MES Tasks > Remove FRU**
4. In the Add/Install/Remove Hardware - Remove FRU, Select FRU Type window, select the system or enclosure from which you are removing the part.
5. Select the type of part that you are removing, and click **Next**.
6. Select the location of the part that you are removing, and click **Add**.
7. After the part is listed in the **Pending Actions** section, click **Launch Procedure** and follow the instructions to remove the part.

**Note:** The HMC might open the information center instructions for removing the part. If so, follow those instructions to remove the part.

---

## Installing a part by using the HMC

You can use the Hardware Management Console (HMC) to perform many service actions, including the installation of a new feature or part.

To install a feature or part into a system or expansion unit that is managed by HMC Version 7, or later, complete the following steps:

1. In the navigation area, expand **Systems Management > Servers**.
2. Select the managed system on which you will install the part.

**Note:** If your part is in a miscellaneous equipment specification (MES), continue with step 3. If your part is contained in the install done by the system services representative (SSR) or in a ship group, go to step 8.

3. In the **Tasks** area, expand **Serviceability > Hardware > MES Tasks > Open MES**.
4. Click **Add MES Order Number**.
5. Enter the number, and click **OK**.
6. Click the newly created order number, and click **Next**. The details of the order number are displayed.
7. Click **Cancel** to close the window.
8. In the **Tasks** area, expand **Serviceability > Hardware > MES Tasks**.
9. Select **Add FRU** (field replaceable unit).
10. In the Add/Install/Remove Hardware-Add FRU, Select FRU Type window, select the system or enclosure into which you are installing the feature.
11. Select the type of feature you are installing, and click **Next**.
12. Select the location code where you will install the feature, and click **Add**.
13. After the part is listed in the **Pending Actions** section, click **Launch Procedure** and follow the instructions to install the feature.

**Note:** The HMC might open external instructions for installing the feature. If so, follow those instructions to install the feature.

---

## Replacing a part by using the HMC

You can use the Hardware Management Console (HMC) to perform many service actions, including exchanging a field replaceable unit (FRU) or part.

If you are exchanging a part to repair a serviceable event, follow those instructions. If you are exchanging a part as a part of any other procedure by using HMC Version 7, or later, complete the following steps:

1. In the navigation area, expand **Systems Management > Servers**.
2. Select the managed system in which you are exchanging a part.
3. In the **Tasks** area, expand **Serviceability > Hardware > Exchange FRU**.
4. Select the system or enclosure from which you want to exchange the part.
5. In the **Replace Hardware - Replace FRU, Select FRU Type** window, select the type of part that you will exchange from the menu, and click **Next**.
6. Select the location code of the part that you will exchange, and click **Add**.
7. After the part is listed in the **Pending Actions** section, click **Launch Procedure** and follow the instructions to exchange the part.

**Note:** The HMC might open external instructions for replacing the part. If so, follow those instructions to replace the part.

---

## Removing a part by using the SDMC

You can use the IBM Systems Director Management Console (SDMC) to perform many service actions, including the removal of a field-replaceable unit (FRU) or part.

To remove a part in a system or expansion unit that is managed by an SDMC, complete the following steps:

1. In the Power Systems Resources area, select the managed system from which you are removing a part.
2. From the **Actions** menu, expand **Service and Support > Hardware > MES Tasks > Remove FRU**.
3. On the **Remove FRU** page, select the enclosure from which you want to remove the part from the **Installed Enclosures** list.
4. Select the type of the part that you are removing, and click **Next**.
5. Select the location of the part that you are removing, and click **Add**.
6. After the part is listed in the **Pending Actions** section, click **Launch Procedure** and follow the instructions to remove the part.

**Note:** The SDMC might open external instructions for removing the part. If so, follow those instructions to remove the part.

---

## Installing a part by using the SDMC

You can use the IBM Systems Director Management Console (SDMC) to perform many service actions, including the installation of a new field-replaceable unit (FRU) or part.

To install a part into a system or expansion unit that is managed by an SDMC, complete the following steps:

1. In the Power Systems Resources area, select the system on which you want to install a part.
2. From the **Actions** menu, expand **Service and Support > Hardware > MES Tasks > Add FRU**.
3. On the **Add FRU** page, select the system or enclosure type from the **Enclosure type** list.
4. Select the FRU type that you are installing, and click **Next**.

5. Select the location code for the location to install, and click **Add**.
6. After the part is placed in the **Pending Actions** section, click **Launch Procedure** and follow the instructions to install the part.

**Note:** The SDMC might open external instructions for installing the feature. If so, follow those instructions to install the part.

---

## Replacing a part by using the SDMC

You can use the IBM Systems Director Management Console (SDMC) to perform many service actions, including exchanging a field-replaceable unit (FRU) or part.

To replace a part by using the SDMC, complete the following steps:

1. In the Power Systems Resource area, select the managed system in which you are exchanging a part.
2. Select one of the following options:
  - If you are replacing a part that is not part of a serviceable event from the **Actions** menu, expand **Service and Support > Hardware > Exchange FRU**.
  - If you are exchanging a part to repair a serviceable event, see Starting a repair action.
3. On the Exchange FRU page, select the enclosure from which you want to replace the part from the **Installed Enclosure Types** list.
4. Select the type of part that you want to exchange, and click **Next**.
5. Select the location code of the part that you want to exchange, and click **Add**.
6. After the part is listed in the **Pending Actions** section, click **Launch Procedure** and follow the instructions to exchange the part.

**Note:** The SDMC might open external instructions for replacing the part. If so, follow those instructions to replace the part.

---

## Verifying the installed part

You can verify a newly installed or replaced part on your system, logical partition, or expansion unit by using the operating system, stand-alone diagnostics, or the Hardware Management Console (HMC).

## Verifying an installed feature or replaced part in an AIX system or logical partition

If you installed feature or replaced a part, you might want to use the tools in the AIX operating system to verify that the feature or part is recognized by the system or logical partition.

To verify the operation of a newly installed feature or replacement part, select the appropriate procedure:

- Verify the installed feature using AIX
- Verifying the replaced part using AIX

Verify the installed feature by using the AIX operating system:

1. Log in as root user.
2. At the command line, type `diag` and press Enter.
3. Select **Advanced Diagnostics Routines** and press Enter.
4. From the **Diagnostic Mode Selection** menu, select **System Verification** and press Enter.
5. When the **Advanced Diagnostic Selection** menu appears, do one of the following:
  - To test a single resource, select the resource that you just installed from the list of resources and press Enter.

- To test all the resources available to the operating system, select **All Resources** and press Enter.
6. Select **Commit**, and wait until the diagnostic programs run to completion, responding to any prompts that appear.
  7. Did the diagnostics run to completion and display the message No trouble was found?
    - **No:** If a service request number (SRN) or other reference code is displayed, suspect a loose adapter or cable connection. Review the installation procedures to ensure that the new feature is installed correctly. If you cannot correct the problem, collect all SRNs or any other reference code information that you see. If the system is running in logical partitioning (LPAR) mode, note the logical partition in which you installed the feature. Contact your service provider for assistance.
    - **Yes:** The new device is installed correctly. Exit the diagnostic programs and return the system to normal operations.

Verify the replacement part by using the AIX operating system:

To verify the operation of a newly installed feature or replacement part, follow these steps:

1. Did you use either the AIX operating system or the online diagnostics service aid concurrent (hot-swap) service to replace the part?
  - No:** Go to step 2.
  - Yes:** Go to step 5.
2. Is the system powered off?
  - No:** Go to step 4.
  - Yes:** Continue with the next step.
3. Start the system and wait until the AIX operating system login prompt is displayed or until apparent system activity on the operator panel or display has stopped.
 

Did the AIX login prompt display?

  - **No:** If a service request number (SRN) or other reference code is displayed, suspect a loose adapter or cable connection. Review the procedures for the part that you replaced to ensure that the new part is installed correctly. If you cannot correct the problem, collect all SRNs or any other reference code information that you see. If the system does not start or you have no login prompt, see: Problems with loading and starting the operating system.
 

If the system is partitioned, note the logical partition in which you replaced the part. Contact your service provider for assistance.
  - **Yes:** Go to step 4.
4. At the command prompt, type `diag -a` and press Enter to check for missing resources. If you see a command prompt, go to step 5.
 

If the **Diagnostic selection** menu is shown with **M** appearing next to any resource, follow these steps:

  - a. Select the resource and press Enter.
  - b. Select **Commit**.
  - c. Follow any instructions that are shown.
  - d. If the *Do you want to review the previously displayed error?* message is shown, select **Yes** and press Enter.
  - e. If an SRN is shown, suspect a loose card or connection. If no obvious problem is shown, record the SRN and contact your service provider for assistance.
  - f. If no SRN is shown, go to step 5.
5. Test the part by doing the following steps:
  - a. At the command line, type `diag` and press Enter.
  - b. From the **Function Selection** menu, select **Advanced Diagnostics Routines** and press Enter.
  - c. From the **Diagnostic Mode Selection** menu, select **System Verification** and press Enter.

- d. Select **All Resources**, or select the diagnostics for the individual part to test only the part you replaced and any devices that are attached to the part you replaced and press Enter.

Did the **Resource Repair Action** menu appear?

**No:** Go to step 6.

**Yes:** Go to step 7.

6. Did the *Testing Complete, No trouble was found* message appear?
  - **No:** There is still a problem. Contact your service provider. **This ends the procedure.**
  - **Yes:** Select **Log Repair Action**, if not previously logged, from the **Task Selection** menu to update the AIX error log. If the repair action was reseating a cable or adapter, select the resource associated with that repair action. If the resource associated with your action is not displayed on the resource list, select **sysplanar0** and press Enter.

**Tip:** This action changes the indicator light for the part from the fault state to the normal state.

Go to step 9.

7. Select the resource for the replaced part from the **Resource Repair Action** menu. When a test is run on a resource in system verification mode, and that resource has an entry in the AIX error log, if the test on the resource was successful, the **Resource Repair Action** menu appears. Complete the following steps to update the AIX error log to indicate that a system-detectable part has been replaced.

**Note:** On systems with an indicator light for the failing part, this action changes the indicator light to the normal state.

- a. Select the resource that has been replaced from the **Resource Repair Action** menu. If the repair action was reseating a cable or adapter, select the resource associated with that repair action. If the resource associated with your action does not appear on the resource list, select **sysplanar0** and press Enter.

- b. Select **Commit** after you make your selections. Did another **Resource Repair Action** display appear?

**No:** If the **No Trouble Found** display appears, go to step 9

**Yes:** Go to step 8.

8. Select the parent or child of the resource for the replaced part from the **Resource Repair Action** menu if necessary. When a test is run on a resource in system verification mode, and that resource has an entry in the AIX error log, if the test on the resource was successful, the **Resource Repair Action** menu appears. Complete the following steps to update the AIX error log to indicate that a system-detectable part has been replaced.

**Note:** This action changes the indicator light for the part from the fault state to the normal state.

- a. From the **Resource Repair Action** menu, select the parent or child of the resource that has been replaced. If the repair action was to reseat a cable or adapter, select the resource associated with that repair action. If the resource associated with your action does not appear on the resource list, select **sysplanar0** and press Enter.

- b. Select **Commit** after you make your selections.

- c. If the **No Trouble Found** display appears, go to step 9.

9. If you changed the service processor or network settings, as instructed in previous procedures, restore the settings to the values they had prior to servicing the system.

10. Did you do any hot-plug procedures before doing this procedure?

**No:** Go to step 11.

**Yes:** Go to step 12 on page 35.

11. Start the operating system, with the system or logical partition in normal mode. Were you able to start the operating system?

**No:** Contact your service provider. **This ends the procedure.**

**Yes:** Go to step 12.

12. Are the indicator lights still on?

- **No. This ends the procedure.**
- **Yes.** Turn off the lights. See the following for instructions: Changing service indicators.

## Verifying the installed part in an IBM i system or logical partition

If you have installed a new feature or part, verify that the system recognizes the feature or part by using the IBM i system service tools.

To verify the installed part, follow these steps:

1. Deactivate the failing item indicator light. For instructions, see “Deactivating the failing-part indicator light” on page 14.
2. Sign on **with at least service level authority**.
3. On the command line of the IBM i session, type `strsst` and press Enter.

**Note:** If you cannot get to the System Service Tools display, use function 21 from the control panel. Alternatively, if the system is managed by Hardware Management Console (HMC), use the Service Focal Point Utilities to get to the Dedicated Service Tools (DST) display.

4. Type your service tools user ID and service tools password on the System Service Tools (SST) Sign On display and press Enter.

**Note:** The service tools password is case-sensitive.

5. Select **Start a service tool** from the System Service Tools (SST) display and press Enter.
6. Select **Hardware service manager** from the Start a Service Tool display and press Enter.
7. Select **Logical hardware resources (buses, IOPs, controllers)** from the Hardware Service Manager display and press Enter. This option allows you to display and work with logical resources. Logical hardware resources are the functional resources of the system used by the operating system.

With the Logical Hardware Resources display, you can show logical hardware resource status or information, and associated packaging hardware resources. Use the online Help information to better understand specific functions, fields, or symbols.

## Deactivating the failing-part indicator light

Use this procedure to turn off any indicator light that you turned on as a part of a service action.

To deactivate the indicator light, follow these steps:

1. Sign on to an IBM i session, **with at least service level authority**.
2. On the command line of the session, type `strsst` and press Enter.

**Note:** If you cannot get to the System Service Tools display, use function 21 from the control panel. Alternatively, if the system is managed by a Hardware Management Console (HMC), use the Service Focal Point utilities to get to the Dedicated Service Tools (DST) display.

3. Type your service tools user ID and service tools password on the System Service Tools (SST) Sign On display and press Enter.

**Remember:** The service tools password is case-sensitive.

4. Select **Start a service tool** from the System Service Tools (SST) display and press Enter.
5. Select **Hardware service manager** from the Start a Service Tool display and press Enter.
6. Select **Work with service action log** from the Hardware Service Manager display and press Enter.

7. On the Select Timeframe display, change the **From: Date and Time** field to a date and time prior to when the problem occurred.
8. Search for an entry that matches one or more conditions of the problem:
  - System reference code
  - Resource
  - Date and time
  - Failing item list
9. Select option 2 (Display failing item information) to display the service action log entry.
10. Select option 2 (Display details) to display location information for the failing part to be replaced. The information displayed in the date and time fields is the date and time for the first occurrence of the specific system reference code for the resource displayed during the time range selected.
11. Select option 7 (Indicator off) to turn off the indicator light.
12. Select the **Acknowledge all errors** function at the bottom of the Service Action Log display, if all problems have been resolved.
13. Close the log entry by selecting option 8 (Close new entry) on the Service Action Log Report display.

## Verifying the installed part in a Linux system or logical partition

If you have installed a new part, learn how to verify that the system recognizes the part.

To verify the newly installed or replaced part, continue with “Verifying an installed part by using stand-alone diagnostics.”

## Verifying an installed part by using stand-alone diagnostics

If you have installed or replaced a part, verify that the system recognizes the new part. You can use stand-alone diagnostics to verify an installed part in an AIX or Linux system, expansion unit, or logical partition.

- If this server is directly attached to another server or attached to a network, ensure communications with the other servers have stopped.
- The stand-alone diagnostics require use of all of the logical partition resources. No other activity can be running on the logical partition.
- The stand-alone diagnostics require access to the system console.

You access these diagnostics from a CD-ROM or from the Network Installation Management (NIM) server. This procedure describes how to use the diagnostics from a CD-ROM. For information on running diagnostics from the NIM server, see Running stand-alone diagnostics from a Network Installation Management server.

To use stand-alone diagnostics, follow these steps:

1. Stop all jobs and applications and then stop the operating system on the system or logical partition.
2. Remove all tapes, diskettes, and CD-ROM.
3. Turn off the system unit power. The next step boots the server or logical partition from the stand-alone diagnostics CD-ROM. If the optical drive is not available as a boot device on the server or logical partition on which you are working, follow these steps:
  - a. Access the ASMI. For information on using the ASMI, see Accessing the ASMI.
  - b. On the ASMI main menu, click **Power/Restart Control**.
  - c. Click **Power On/Off System**.
  - d. Select the **Service mode boot from default boot list** option in the AIX or Linux logical partition mode boot drop-down menu.
  - e. Click **Save settings and power on**. When the optical drive is powered on, insert the stand-alone diagnostic CD-ROM.



- f. Go to step 5.
4. Turn on the system unit power and immediately insert the diagnostics CD-ROM into the optical drive.
5. After the **keyboard** POST indicator displays on the system console and before the last POST indicator (**speaker**) displays, press the numeric 5 key on the system console to indicate that a service mode boot must be initiated by using the default-service mode boot list.
6. Enter any requested password.
7. At the **Diagnostic Operating Instructions** display, press Enter.

**Tip:** If a service request number (SRN) or other reference code is displayed, suspect a loose adapter or cable connection.

**Note:** If you received an SRN or any other reference code when you attempted to start the system, contact your service provider for assistance.

8. If the terminal type is requested, select the **Initialize Terminal** option on the Function Selection menu to initialize the operating system.
9. From the Function Selection menu, select **Advanced Diagnostics Routines** and press Enter.
10. From the Diagnostic Mode Selection menu, select **System Verification** and press Enter.
11. When the Advanced Diagnostic Selection menu appears, select **All Resources**, or test only the part you replaced, and any devices that are attached to the part you replaced, by selecting the diagnostics for the individual part and press Enter.
12. Did the Testing Complete, No trouble was found message appear?
  - **No:** There is still a problem. Contact your service provider.
  - **Yes:** Go to step 13.
13. If you changed the service processor or network settings, as instructed in previous procedures, restore the settings to the value they had prior to servicing the system.
14. If the indicator lights are still on, follow these steps:
  - a. Select **Identify and Attention Indicators** from the Task Selection menu to turn off the system attention and indicator lights and press Enter.
  - b. Select **Set System Attention Indicator to NORMAL** and press Enter.
  - c. Select **Set All Identify Indicators to NORMAL** and press Enter.
  - d. Choose **Commit**.

**Note:** This changes the system attention and identify indicators from the *Fault* state to the *Normal* state.

- e. Exit to the command line.

## Verifying the installed part by using the HMC

If you have installed or replaced a part, use the Hardware Management Console (HMC) to update your HMC records after you have completed a service action on your server. If you have reference codes, symptoms, or location codes that you used during the service action, locate the records for use during this procedure.

To verify the installed part, complete these steps:

1. At the HMC, examine the service action event log for any open service action events. See “Viewing serviceable events by using the HMC” on page 39 for details.
2. Are there any service action events that are open?

**No:** If the system attention LED is still on, use the HMC to turn off the LED. See “Activating and deactivating LEDs by using the HMC” on page 38. **This ends the procedure.**

**Yes:** Continue with the next step.

3. Record the list of open service action events.
4. Examine the details of the open service action event. Is the error code associated with this service action event the same as you gathered earlier.
  - **No:** Select one of the following options:
    - Review the other serviceable events, find one that does match, and continue with the next step.
    - If the log does not match what you had gathered earlier, contact your service provider.
  - **Yes:** Continue with the next step.
5. Select and highlight the service action event from the Error Associated With This Serviceable Event window.
6. Click **Close Event**.
7. Add comments for the serviceable event. Include any unique additional information. Click **OK**.
8. Did you replace, add, or modify a field replaceable unit (FRU) of the open service action event?
  - **No:** Select the **No FRU Replaced for this Serviceable Event** option, and click **OK** to close the service action event.
  - **Yes:** Perform the following steps:
    - a. From the FRU list, select a FRU that you need to update.
    - b. Double-click the FRU and update the FRU information.
    - c. Click **OK** to close the service action event.
9. If you continue to have problems, contact your service provider.

### Activating and deactivating LEDs by using the HMC

Use this procedure to activate or deactivate LEDs by using Service Focal Point from the Hardware Management Console (HMC).

#### Deactivating a system attention LED or partition LED by using the HMC:

You can deactivate the attention LED for a system or logical partition if you decide that a problem is not a high priority and you decide to repair the problem at a later time. The deactivation also allows the LED to be activated again when another problem occurs.

To deactivate a system attention LED by using HMC, complete the following steps:

1. In the navigation area, open **Systems Management**.
2. Open **Servers** and select the required system.
3. In the content area, select the required partition.
4. Select **Tasks > Operations > Deactivate Attention LED**. A confirmation window is displayed with an indication that there still might be open problems with the system.
5. Click **OK** to continue with the deactivation. A window is displayed that provides the details of the system or partition, and a confirmation that the system or logical partition attention LED was deactivated.

#### Activating or deactivating an identify LED by using the HMC:

The system provides several LEDs that help identify various components, such as enclosures or field replaceable units (FRUs), in the system. For this reason, they are called *identify LEDs*.

You can activate or deactivate the following types of identify LEDs:

- **Identify LED for an enclosure** If you want to add an adapter to a specific drawer (enclosure), you need to know the machine type, model, and serial number (MTMS) of the drawer. To determine whether you have the correct MTMS for the drawer that needs the new adapter, you can activate the LED for a drawer and verify that the MTMS corresponds to the drawer that requires the new adapter.

- **Identify LED for a FRU associated with a specified enclosure** If you want to hook up a cable to a specific I/O adapter, you can activate the LED for the adapter which is a field replaceable unit (FRU), and then physically check to see where you should hook up the cable. This is especially useful when you have several adapters with open ports.

To activate or deactivate an identify LED for an enclosure or FRU, follow these steps:

1. In the navigation area, open **Systems Management**.
2. Select **Servers**.
3. In the content area, check the box for the appropriate System.
4. Select **Tasks > Operations > LED Status > Identify LED**.
5. To activate or deactivate an identify LED for an enclosure, select an enclosure from the table, and click either **Activate LED** or **Deactivate LED**. The associated LED is either turned on or off.
6. To activate or deactivate an identify LED for a FRU, select an enclosure from the table and click **List FRUs**.
7. Select one or more FRUs from the table, and click either **Activate LED** or **Deactivate LED**. The associated LED is either turned on or off.

### Viewing serviceable events by using the HMC

Use this procedure to view a serviceable event, including details, comments, and service history.

To view serviceable events and other information about the events, you must be a member of one of the following roles:

- Super administrator
- Service representative
- Operator
- Product engineer
- Viewer

To view serviceable events, follow these steps:

1. In the navigation area, select **Service Management**.
2. Select **Manage Serviceable Events**.
3. Select the criteria for the serviceable events that you want to view, and click **OK**. The Serviceable Event Overview window opens. The list shows all serviceable events that match your selection criteria. You can use the menu options to perform actions on the serviceable events.
4. Select a line in the Serviceable Event Overview window, and select **Selected > View Details**. The Serviceable Event Details window opens, showing detailed information about the serviceable event. The upper table shows information, such as problem number and reference code. The lower table shows the field replaceable units (FRUs) associated with this event.
5. Select the error for which you want to view comments and history, and follow these steps:
  - a. Select **Actions > View Comments**.
  - b. When you are finished viewing the comments, click **Close**.
  - c. Select **Actions > View Service History**. The Service History window opens, showing service history associated with the selected error.
  - d. When you are finished viewing the service history, click **Close**.
6. When you are finished, click **Cancel** twice to close the Serviceable Event Details window and the Serviceable Event Overview window.

## Verifying the installed part by using the SDMC

If you installed or replaced a part, use the IBM Systems Director Management Console (SDMC) to update your SDMC records after you have completed a service action on your server. If you have reference codes, symptoms, or location codes that you used during the service action, locate the records for use during this procedure.

To verify the installed part, complete these steps:

1. From the SDMC, examine the service action event log for any open service action events. See “Viewing serviceable events by using the SDMC” on page 41 for details.
2. Are there any service action events that are open?
  - No:** If the system attention LED is still on, use the SDMC to turn off the LED. See “Activating and deactivating LEDs by using the SDMC.” **This ends the procedure.**
  - Yes:** Continue with the next step.
3. Record the list of open service action events.
4. Examine the details of the open service action event. Is the error code associated with this service action event the same as you gathered earlier.
  - **No:** Select one of the following options:
    - Review the other serviceable events, find one that does match, and continue with the next step.
    - If the log does not match what you had gathered earlier, contact your service provider.
  - **Yes:** Continue with the next step.
5. Select and highlight the service action event from the Error Associated With This Serviceable Event window.
6. Click **Delete** or **Ignore**.

**Note:** These options are only available from the problem event log.

## Activating and deactivating LEDs by using the SDMC

Use this procedure to activate or deactivate LEDs by using the IBM Systems Director Management Console (SDMC).

### Deactivating a system attention LED or partition LED by using the SDMC:

You can deactivate a system attention LED or a logical partition LED. For example, you might determine that a problem is not a high priority and decide to repair the problem at a later time. However, you want to be alerted if another problem occurs, so you must deactivate the system attention LED so that it can be activated again if another problem occurs.

To deactivate the system attention LED, complete the following steps:

1. On the Resources tab, select the appropriate host or virtual server.
2. Select **Actions > Service and Support > Hardware > System Attention LED**.
3. Select **Deactivate System Attention LED**. A confirmation window is displayed that provides the following information:
  - A verification that the system attention LED was deactivated.
  - An indication that there still might be open problems within the system.
  - An indication that you cannot activate the system attention LED.
4. Select one of the virtual servers, and select **Deactivate System Attention LED**. A confirmation window is displayed that provides the following information:
  - A verification that the system attention LED was deactivated.
  - An indication that there still might be open problems within the logical partition.
  - An indication that you cannot activate the virtual server LED.

### Activating or deactivating an identify LED by using the SDMC:

The system provides several LEDs that help identify various components, such as enclosures or field replaceable units (FRUs). For this reason, they are called *identify LEDs*.

You can activate or deactivate the following types of identify LEDs:

- **Identify LED for an enclosure** If you want to add an adapter to a specific drawer (enclosure), you need to know the machine type, model, and serial number (MTMS) of the drawer. To determine whether you have the correct MTMS for the drawer that needs the new adapter, you can activate the LED for a drawer and verify that the MTMS corresponds to the drawer that requires the new adapter.
- **Identify LED for a FRU associated with a specified enclosure** If you want to hook up a cable to a specific I/O adapter, you can activate the LED for the adapter which is a field replaceable unit (FRU), and then physically check to see where you should hook up the cable. This is especially useful when you have several adapters with open ports.

To activate or deactivate an identify LED for an enclosure or FRU, follow these steps:

1. On the Resources tab, select the appropriate host or virtual server.
2. Select **Actions > Service and Support > Hardware > Identify LED**.
3. In the Identify LED, Select Enclosure window, select the system unit or enclosure.
4. To activate or deactivate an identify LED, click either **Activate LED** or **Deactivate LED**. The associated LED is either turned on or off.
5. To activate or deactivate an identify LED for a FRU, select a system or enclosure from the table, and then click **List FRUs**.
6. Select one or more FRUs from the table, and click either **Activate LED** or **Deactivate LED**. The associated LED is either turned on or off.

### Viewing serviceable events by using the SDMC

Use this procedure to view a serviceable event, including details, comments, and service history.

To view serviceable events, follow these steps:

1. On the Resources tab, select the appropriate host or virtual server.
2. Select **Actions > System Status and Health > Event Log**.
3. Optional: You can narrow the event criteria by using the Event filter menu.
4. Select a line in the Events window, and select **Actions > Properties**. The Properties window opens, showing detailed information about the serviceable event. The table shows information, such as problem number, reference code, and the field replaceable units (FRUs) associated with this event.

### Verifying an installed part or replaced part on a system or logical partition by using Virtual I/O Server tools

If you installed or replaced a part, you might want to use the tools in Virtual I/O Server (VIOS) to verify that the part is recognized by the system or logical partition.

#### Verifying the installed part by using VIOS

You can verify the operation of a newly installed part or a replacement part.

Perform the following steps to verify an installed or replaced part:

1. Log in as root user.
2. At the command line, type `diagmenu` and press Enter.
3. Select **Advanced Diagnostics Routines** and press Enter.
4. From the **Diagnostic Mode Selection** menu, select **System Verification** and press Enter.
5. When the **Advanced Diagnostic Selection** menu appears, do one of the following steps:

- To test a single resource, select the resource that you just installed from the list of resources and press Enter.
  - To test all the resources available to the operating system, select **All Resources** and press Enter.
6. Select **Commit**, and wait until the diagnostic programs run to completion, responding to any prompts that appear.
  7. Did the diagnostics run to completion and display the message No trouble was found?
    - **No:** If a service request number (SRN) or other reference code is displayed, suspect a loose adapter or cable connection. Review the installation procedures to ensure that the new part is installed correctly. If you cannot correct the problem, collect all SRNs or any other reference code information that you see. If the system is running in LPAR mode, note the logical partition in which you installed the part. Contact your service provider for assistance.
    - **Yes:** The new device is installed correctly. Exit the diagnostic programs and return the system to normal operations.

### Verify the replacement part by using VIOS

To verify the operation of a newly installed part or replacement part, complete the following steps:

1. Did you replace the part by using either VIOS or the online diagnostics service aid's concurrent (hot-swap) service operation?
  - **No:** Go to step 2.
  - **Yes:** Go to step 5.
2. Is the system powered off?
  - **No:** Go to step 4.
  - **Yes:** If the system supports slow boot, set the system to perform a slow boot. For information, see *Performing a slow boot*.
3. Start the system and wait until the VIOS operating system login prompt displays or until apparent system activity on the operator panel or display has stopped. Did the VIOS login prompt display?
  - **No:** If an SRN or other reference code is displayed, suspect a loose adapter or cable connection. Review the procedures for the part that you replaced to ensure that the new part is installed correctly. If you cannot correct the problem, collect all SRNs or any other reference code information that you see. If the system does not start or you have no login prompt, see *Problems with loading and starting the operating system*.  
If the system is partitioned, note the logical partition in which you replaced the part. Contact your service provider for assistance.
  - **Yes:** Go to step 4.
4. At the command prompt, type `diag -a` and press Enter to check for missing resources. If you see a command prompt, go to step 5.  
If the **Diagnostic selection** menu is shown with **M** appearing next to any resource, follow these steps:
  - a. Select the resource and press Enter.
  - b. Select **Commit**.
  - c. Follow any instructions that are shown.
  - d. If a *Do you want to review the previously displayed error?* message is shown, select **Yes** and press Enter.
  - e. If an SRN is shown, suspect a loose card or connection. If no obvious problem is shown, record the SRN and contact your service provider for assistance.
  - f. If no SRN is shown, go to 5.
5. Test the part by doing the following:
  - a. At the command line, type `diagmenu` and press Enter.
  - b. From the **Function Selection** menu, select **Advanced Diagnostics Routines** and press Enter.

- c. From the **Diagnostic Mode Selection** menu, select **System Verification** and press Enter.
  - d. Select **All Resources**, or select the diagnostics for the individual part to test only the part you replaced, and any devices that are attached to the part you replaced and press Enter.  
Did the **Resource Repair Action** menu appear?
    - **No:** Go to step 6.
    - **Yes:** Go to step 7.
6. Did the *Testing Complete, No trouble was found* message appear?
    - **No:** There is still a problem. Contact your service provider. **This ends the procedure.**
    - **Yes:** Select **Log Repair Action**, if not previously logged, from the **Task Selection** menu to update the error log. If the repair action was reseating a cable or adapter, select the resource associated with that repair action. If the resource associated with your action is not displayed on the Resource List, select **sysplanar0** and press Enter.

**Tip:** This action changes the indicator light for the part from the fault state to the normal state.  
Go to step 9.
  7. Select the resource for the replaced part from the **Resource Repair Action** menu. When a test is run on a resource in system verification mode, and that resource has an entry in the error log, if the test on the resource was successful, the **Resource Repair Action** menu appears. Complete the following steps to update the error log to indicate that a system-detectable part has been replaced. On systems with a indicator light for the failing part, this changes the indicator light to the normal state.
    - a. Select the resource that has been replaced from the **Resource Repair Action** menu. If the repair action was reseating a cable or adapter, select the resource associated with that repair action. If the resource associated with your action does not appear on the Resource List, select **sysplanar0**. Press Enter.
    - b. Select **Commit** after you make your selections. Did another **Resource Repair Action** display appear?
      - **No:** If the **No Trouble Found** display appears, go to step 9.
      - **Yes:** Go to step 8.
  8. Select the parent or child of the resource for the replaced part from the **Resource Repair Action** menu if necessary. When a test is run on a resource in system verification mode, and that resource has an entry in the error log, if the test on the resource was successful, the **Resource Repair Action** menu appears. Complete the following steps to update the error log to indicate that a system-detectable part has been replaced. This changes the indicator light for the part from the fault state to the normal state.
    - a. From the **Resource Repair Action** menu, select the parent or child of the resource that has been replaced. If the repair action was to reseat a cable or adapter, select the resource associated with that repair action. If the resource associated with your action does not appear on the Resource List, select **sysplanar0**. Press Enter.
    - b. Select **Commit** after you make your selections.
      - a. If the **No Trouble Found** display appears, go to step 9.
  9. If you changed the service processor or network settings, as instructed in previous procedures, restore the settings to the values they had prior to servicing the system.
  10. Did you do any hot-plug procedures before doing this procedure?
    - **No:** Go to step 11.
    - **Yes:** Go to step 12.
  11. Start the operating system, with the system or logical partition in normal mode. Were you able to start the operating system?
    - **No:** Contact your service provider. **This ends the procedure.**
    - **Yes:** Go to step 12.
  12. Are the indicator lights still on?

- **No:** This ends the procedure.
  - **Yes.** Turn off the lights. For instructions, see Changing service indicators.
- 

## Verifying a repair

Use these procedures to verify hardware operation after making repairs to the system.

Choose from the following options:

- To verify the repair of a system that is currently powered off, go to step 1.
  - To verify the repair of a system that is currently powered on with no operating system loaded, go to step 3.
  - To verify the repair of a system that is currently powered on and that has an operating system loaded, go to step 5.
1. Power on the server and all attached I/O enclosures.

**Did all the enclosures power on?**

**Yes:** Go to step 3.↓ Go to step 3.

**No:** Continue with the next step.

---

2. Choose from the following options:

- If the original problem was that an enclosure would not power on and you have another FRU to replace, locate and replace the next field-replaceable unit (FRU).
  - If the next FRU in the FRU list is an isolation procedure, perform the isolation procedure.
  - If the original problem was that an enclosure would not power on and you have an isolation procedure to complete, perform the isolation procedure.
  - If the original problem was that an enclosure would not power on and there are no more FRUs or isolation procedures in the FRU list, contact your next level of support.
  - If you have a new problem, perform problem analysis and repair the new problem.
- 

3. Load the operating system.

**Did the operating system load successfully?**

**Yes:** Go to step 5.

**No:** Continue with the next step.

---

4. Choose from the following options:

- If the original problem was a failing disk drive that contained the operating system software, go to step 5.
  - If the original problem was that the operating system would not load and you have another FRU to replace, go to your FRU locations section to locate the next FRU.
  - If the next FRU in the FRU list is an isolation procedure, perform the isolation procedure.
  - If the original problem was that the operating system would not load and you have an isolation procedure to complete, perform the isolation procedure.
  - If the original problem was that the operating system would not load and there are no more FRUs or isolation procedures in the FRU list, contact your next level of support.
  - If you have a new problem, perform problem analysis and repair the new problem.
- 

5. Choose from the following options:

- “Verifying the repair in AIX” on page 45
- “Verifying the repair in Linux” on page 50
- “Verifying a repair by using an IBM i system or logical partition” on page 48



## Verifying the repair in AIX

You can use this procedure to verify that a repair is complete using the AIX operating system.

Use this maintenance analysis procedure (MAP) to check out the server after a repair is completed.

1. Did you replace a disk drive in the root volume group?

**No** Go to step 3.

**Yes** Continue with the next step.

---

2. Run stand-alone diagnostics either from a CD or from a Network Installation Management (NIM) server.

### Did you encounter any problems?

**No** Reinstall the operating system and continue with step 5.

**Yes** If the original problem still exists, replace the field-replaceable unit (FRU) or perform the isolation procedure that is next in the FRU list. If you have reached the end of the FRU list, contact your next level of support.

If a new problem has occurred, go to Beginning problem analysis.

---

3. Did you replace a FRU with the power turned on and concurrently with system operations?

**No** Go to step 5.

**Yes** Continue with the next step.

---

4. Did you use an AIX diagnostics service aid hot-swap operation to change the FRU?

**Yes** Go to step 6.

**No** Go to step 7 on page 46.

**Note:** The AIX diagnostic service aid was used if a resource was removed by using the **Hot Plug** task.

---

5. If any FRUs have been removed that should be reinstalled, reinstall them now:

1. If the system is not powered on, power it on now.

2. Perform a slow boot.

3. Wait until the AIX operating system login prompt is displayed or until system activity on the operator panel or display has stopped.

4. Did you encounter any problems?

**No** Continue at step 6.

**Yes** If the original problem still exists, replace the FRU or perform the isolation procedure that is next in the FRU list. If you have reached the end of the FRU list, contact your next level of support.

If a new problem occurs, go to Beginning problem analysis.

---

6. If the Resource Repair Action menu is already displayed, go to step 9 on page 46; otherwise, perform the following steps:

1. Log into the operating system either with root authority (if needed, ask the customer to enter the password) or use the CE login.
  2. Enter `diag -a` command and check for missing resources. Follow any instructions that are displayed. If an SRN displays, suspect a loose card or connection. If no instructions are displayed, no resources were detected as missing. Continue with the next step.
- 

7. Perform the following steps:

1. Enter `diag` at the command prompt.
2. Press Enter.
3. Select the **Diagnostics Routines** option.
4. When the Diagnostic Mode Selection menu is displayed, select **System verification**.
5. When the Diagnostic Selection menu is displayed, select the **All Resources** option or test the FRUs you exchanged and any devices that are attached to the FRUs you exchanged by selecting the diagnostics for the individual FRU.

Did the Resource Repair Action menu (801015) display?

**No** Continue with the next step.

**Yes** Go to step 9.

---

8. Did the TESTING COMPLETE, no trouble was found menu (801010) display?

**Yes** Use the **Log Repair Action** option, if not previously logged, in the TASK SELECTION menu to update the AIX error log. If the repair action was reseating a cable or adapter, select the resource associated with that repair action.

If the resource associated with your action is not displayed on the resource list, select **sysplanar0**.

**Note:** If the system attention indicator is on, this action will set it back to the normal state.

Go to step 11 on page 47.

**No** If the original problem still exists, replace the FRU or perform the isolation procedure that is next in the FRU list. If you have reached the end of the FRU list, contact your next level of support.

If a new problem occurs go to Beginning problem analysis.

---

9. When a test is run on a resource in system verification mode, that resource has an entry in the AIX error log. If the test on that resource was successful, the Resource Repair Action menu is displayed. After replacing a FRU, you must select the resource for that FRU from the Resource Repair Action menu. This updates the AIX error log to indicate that a system-detectable FRU has been replaced.

**Note:** If the system attention indicator is on, this action will set it back to the normal state.

Perform the following steps:

1. Select the resource that has been replaced from the Resource Repair Action menu. If the repair action was reseating a cable or adapter, select the resource associated with that repair action. If the resource associated with your action is not displayed on the resource list, select **sysplanar0**.
2. Press **Commit** after you make your selections.

**Did another Resource Repair Action (801015) display?**

- No** If the No Trouble Found menu displays, go to step 11.  
**Yes** Continue with the next step.
- 

10. The parent or child of the resource you just replaced might also require that you run the Resource Repair Action service aid on it.

When a test is run on a resource in system verification mode, that resource has an entry in the AIX error log. If the test on the resource was successful, the Resource Repair Action menu displays.

After replacing that FRU, you must select the resource for that FRU from the Resource Repair Action menu. This updates the AIX error log to indicate that a system-detectable FRU has been replaced.

**Note:** If the system attention indicator is on, this action will set it back to the normal state.

Perform the following steps:

1. From the RESOURCE REPAIR ACTION menu, select the parent or child of the resource that has been replaced. If the repair action was reseating a cable or adapter, select the resource associated with that repair action. If the resource associated with your action is not displayed on the resource list, select **sysplanar0**.
  2. Press **COMMIT** after you make your selections.
  3. If the No Trouble Found menu is displayed, continue with the next step.
- 

11. If you changed the service processor or network settings, as instructed in previous MAPs, restore the settings to the value they had prior to servicing the system. If you ran stand-alone diagnostics from CD-ROM, remove the stand-alone diagnostics CD-ROM from the system.

**Did you perform service on a RAID subsystem that involved changing of the PCI RAID adapter cache card or changing the configuration?**

**Note:** This information does not apply to the PCI-X RAID adapter or cache.

- No** Go to the close of call procedure.  
**Yes** Continue with the next step.
- 

12. Use the **Recover Options** selection to resolve the RAID configuration. To do this, perform the following steps:

1. On the PCI SCSI Disk Array Manager display, select **Recovery options**.
  2. If a previous configuration exists on the replacement adapter, this must be cleared. Select **Clear PCI SCSI Adapter Configuration** and press F3.
  3. On the Recovery Options screen, select **Resolve PCI SCSI RAID Adapter Configuration**.
  4. On the Resolve PCI SCSI RAID Adapter Configuration screen, select **Accept Configuration on Drives**.
  5. On the PCI SCSI RAID Adapter selections menu, select the adapter that you changed.
  6. On the next screen, press Enter.
  7. When you see the Are You Sure selection menu, press Enter to continue.
  8. If you see a Failed status message, verify that you selected the correct adapter, and then repeat this procedure. When the recovery is complete, exit the operating system.
  9. Go to the Closing a service call procedure.
- 

## Verifying a repair by using an IBM i system or logical partition

Use this procedure to verify a repair by using the IBM i operating system.

1. Was the system powered off during the repair?  
**Yes:** Continue with the next step.  
**No:** Continue with step 3.
2. Perform the following tasks:
  - a. Verify that the power cable is plugged into the power outlet.
  - b. Verify that power is available at the customer's power outlet.
3. Was the partition powered off during the repair?  
**Yes:** Continue with the next step.  
**No:** Continue with step 6.
4. Select the IPL type and mode for the system or logical partition that the customer uses (see IPL type mode and speed options in the Service functions).
5. Start an IPL by powering on the system or partition (see Powering on and powering off). Did the system complete the IPL?  
**Yes:** Continue with the next step.  
**No:** This might be a new problem. Go to the Starting a repair action. **This ends the procedure.**
6. Did the system or partition remain running throughout the repair, and was the I/O processor, I/O adapter, or storage device replaced?  
**Yes:** Continue with step 10.  
**No:** Continue with the next step.
7. Use the service action log or serviceable event view (if the system is managed by an HMC) to look for any reference codes that are related to this IPL (see Searching the service action log). Are there any reference codes that are related to this IPL?  
**Yes:** Continue with the next step.  
**No:** If the problem was related to removable media or communications, perform the verification procedures in the Service functions to verify that the problem is corrected. Then return the system to the customer and have the customer verify the system date and time. **This ends the procedure.**

8. Is the new reference code the same as the original reference code?
  - Yes:** Continue with the next step.
  - No:** A new symptom might have occurred. Go to the Start of call procedure. **This ends the procedure.**
9. Are there any other failing items that remain to be replaced?
  - Yes:** Replace the next failing item listed for this reference code. **This ends the procedure.**
  - No:** Contact your next level of support for assistance. **This ends the procedure.**
10. Was concurrent maintenance performed on an optical storage unit?
  - Yes:** The product activity log and service action log, in most cases, contain a reference code for the optical storage unit when concurrent maintenance is performed. You can ignore this reference code. Perform the following:
    - Perform the verification procedures in the Service functions topic to verify that the problem is corrected.
    - Return the system to the customer and have the customer verify the system date and time. **This ends the procedure.**
  - No:** Continue with the next step.
11. Use the service action log to look for any new reference codes (see Using the Service Action Log). Are there any new reference codes?
  - Yes:** Continue with the next step.
  - No:** Go to step 14.
12. Is the new reference code the same as the original reference code?
  - Yes:** Continue with the next step.
  - No:** A new symptom might have occurred. Go to the Start of call procedure to determine the cause of the problem. **This ends the procedure.**
13. Are there any other failing items that need to be replaced?
  - Yes:** Replace the next failing item listed for the reference code. **This ends the procedure..**
  - No:** Contact your next level of support for assistance. **This ends the procedure.**
14. Are you working with a tape device?
  - Yes:** Perform the verification procedures in the Service functions to verify that the problem is corrected. After the verification test is complete, the tape device description will be set to the failed state because a resource change was detected. Perform the following tasks:
    - Vary the tape device description off and then on.
    - Return the system to the customer and have the customer verify the system date and time. Then go to Verifying the repair from the HMC. **This ends the procedure.**
  - No:** Continue with the next step.
15. Are you working with an IOP or an IOA?
  - Yes:** Use the display hardware configuration service function to check for any missing or failed hardware:
    - On the command line, enter the STRSST (Start System Service Tools command). If you cannot get to SST, select DST. Do not IPL the system or partition to get to DST.
    - On the Start Service Tools Sign On display, enter the user ID with the service authority and password.
    - Select **Start a service tool > Hardware service manager > Logical hardware resources > System bus resources.**
    - Select the function key for **Include nonreporting resources.**
    - If the IOP and IOA that you just replaced is a failed or nonreporting resource, the problem has not been fixed. Continue to the next failing item in the failing item list. **This ends the procedure.**

**No:** Perform the verification procedures in the Service functions topics to verify that the problem is corrected. Resources that usually vary on automatically during an IPL, or that were previously varied on manually, might need to be varied on again after the verification procedures are complete. Return the system to the customer and have the customer verify the system date and time. **This ends the procedure.**

## Verifying the repair in Linux

You can use this procedure to verify that a repair is complete by using the Linux operating system.

1. Run stand-alone diagnostics from either a CD or from a Network Installation Management (NIM) server. See Running the stand-alone diagnostics from CD-ROM.

### Did you encounter any problems?

**No** Reboot the operating system and continue with the close of call procedure.

**Yes** If the original problem still exists, replace the field-replaceable unit (FRU) or perform the isolation procedure that is next in the FRU list. If you have reached the end of the FRU list, contact your next level of support.

If a new problem has occurs go to Beginning problem analysis and repair the new problem.

---

## Verifying the repair from the management console

Perform these procedures to close problem numbers, clear hardware messages, and prepare the server to return to the customer by using the management console.

Follow this checklist before performing the procedures:

- You return the server to the state that the customer normally uses, such as IPL type, IPL mode, and the way the system is configured or partitioned.

**Attention:** Before returning the system to the customer, remove the system from service mode. If the system is left in service mode, it automatically places a call for service every 2 hours.

- While you were performing the problem analysis on the original serviceable event, other serviceable-event numbers might have been opened. Close all serviceable events that were opened as a result of your service activity.
- Server verification has been performed and there are no problems that require additional service actions.
- If the repair was done by using the HMC online repair procedures, ensure that the original serviceable event is now closed.

1. Is a management console used to manage the server that you are servicing?

- **Yes:** Continue with the next step.
  - **No:** Return to the “Verifying a repair” on page 44. **This ends the procedure.**
- 

2. Are you closing a service event that was a repair on the management console personal computer?

- **Yes:** Continue with the next step.
  - **No:** Go to step 4.
- 

3. Power on the management console. Did the power-on process complete without errors?

- **Yes:** Ensure that the management console can be used to perform server management tasks, and return the management console to normal operations. Go to “Closing a service call” on page 51. **This ends the procedure.**
  - **No:** Go to the *HMC isolation procedures*. **This ends the procedure.**
- 

4. Log into the management console as the service representative. If invalid user or invalid password is displayed, get the correct login information from the system administrator.

1. If logged into the System Manager, select **Exit from the Console**, located in the System Manager window.
  2. Log in to the System Manager with the following:
    - User identification - service
    - Password - service mode
- 

#### 5. View Serviceable Event Details.

1. In the navigation area, click **Service Applications**.
  2. In the navigation area, click **Service Focal Point**.
  3. In the Contents area, click **Manage Serviceable Events**.
  4. Designate the set of Serviceable Events you want to view. When you are finished, click **OK**. The **Service Event Overview** window opens.
- 

**Note:** Only the events that match all of the criteria you specify are shown.

#### 6. Close open or delayed events.

1. Select the problem to close in the Service Event Overview window.
  2. Select the **Selected** menu, located on the menu bar.
  3. Click **Close Event**.
  4. Enter your comments in the **Serviceable Event Comments** window, and click **Close Event**.
  5. Close all events associated with the problem on which you were working.
- 

#### 7. Did the Service Event Overview window contain the event or events on which you were working?

- **Yes:** Return the HMC to normal operations. Go to "Closing a service call." **This ends the procedure.**
  - **No:** Go to Detecting problems. **This ends the procedure.**
- 

## Closing a service call

Perform these procedures to close serviceable events, clear hardware messages, and prepare the server to return to the customer.

Follow this checklist before performing the procedure:

- Return the server to the state that the customer normally uses such as IPL type, IPL mode, and the way the system is configured or partitioned.

**Attention:** Before returning the system to the customer, remove the system from service mode. If the system is left in service mode, it automatically places a call for service every two hours.
  - While you were performing the problem analysis on the original serviceable event, other serviceable events might have been opened. Close all serviceable events that were opened as a result of your service activity.
  - Ensure that server verification has been performed and no problems require additional service actions.
  - If the repair was done using the management console online repair procedures, ensure that the original serviceable event is now closed.
1. Record the system reference code (SRC), or symptom, and the location code of the field-replaceable unit (FRU) you replaced, for future reference. Is the server managed by a management console?

- **Yes:** Continue with the next step.
  - **No:** Do one of the following steps:
    - If the server is managed by Integrated Virtualization Manager (IVM), go to “Closing a service call by using Integrated Virtualization Manager” on page 60.
    - If the server is not partitioned and is running the AIX or Linux operating system, go to “Closing a service call by using AIX or Linux” on page 56.
- 

2. On the Hardware Management Console (HMC), open **Manage Serviceable Events** and examine the service action event log for any open service action events.

---

3. Are any service action events open?

- **Yes:** Continue with the next step.
  - **No:** If the system attention LED is still on, turn off the LED as described in “Activating and deactivating LEDs” on page 64. Return the system to the customer. **This completes the repair.**
- 

4. Record the list of open service action events.

---

5. From the list of serviceable events recorded in step 4, complete the following steps 6 - step 32 on page 55 for each open service action event.

---

6. Determine the error class of the serviceable event. Record for future use.

---

7. Examine the details of the open service action event.

Is the error code that is associated with this service action event the same as recorded in step 1 on page 51?

- **Yes:** Go to step 11 on page 53.
  - **No:** Continue with the next step.
- 

8. Examine the FRU list of the service action event. Are any FRUs listed for the service action event?

- **Yes:** Continue with the next step.
  - **No:** Go to step 11 on page 53.
- 

9. Is the FRU list identical that is, the same FRUs, same number of FRUs, and same order of FRUs) to the FRU list of the error code recorded in step 1 on page 51?

- **Yes:** Go to step 11 on page 53.
  - **No:** Continue with the next step.
- 

10. The FRU list is different. Is the FRU you replaced and recorded in step 1 on page 51 in the list of FRUs for this service action event?



- **Yes:** Continue with the next step.
  - **No:** Go to step 32 on page 55.  
**Note:** Some service action events will remain open when you leave this MAP. Further service actions might be required to complete the repair.
- 

11. Examine the details of this service action event, and record the partitions involved in this service action event for use in a later step.

---

12. Is the error code associated with this service action event of the form A11-xxx or A01-xxx?

- **Yes:** Continue with the next step.
  - **No:** Go to step 17.
- 

13. Have you begun a list of *Axx* partitions from prior service action events that you processed in this MAP?

- **Yes:** Go to step 15.
  - **No:** Continue with the next step.
- 

14. Begin a new list of *Axx* partitions by copying the list of partitions obtained in step 11. Go to step 16.

---

15. Add the partition list obtained in step 11 to the existing list of *Axx* partitions obtained from processing previous service action events in this maintenance analysis procedure (MAP).

---

16. Remove all entries in the list of all partitions you recorded in step 11. If you are referred to the list of partitions obtained in step 11 in future steps, the list is empty. Go to step 17.

---

17. Select and highlight the service action event from the Error Associated With This Serviceable Event window.

---

18. Click **Close Event**.

---

19. Add comments for the serviceable event. Include any unique additional information. Click **OK**. The following steps will add or update FRU information.

---

20. Did you replace, add, or modify a FRU of the open service action event?

- **Yes:** Continue with the next step.
  - **No:** Go to step 22 on page 54.
-

21. From the FRU list, select a FRU that you need to update. Double-click the FRU, and update the FRU information. Go to step 23.

---

22. Select the **No FRU Replaced for this Serviceable Event** option.

---

23. Click **OK** to close the service action event.

---

24. Is the list of all partitions you recorded in step 11 on page 53 empty?

- **Yes:** Go to step 32 on page 55.
  - **No:** Continue with the next step.
- 

25. Does the list of all partitions you recorded in step 11 on page 53 contain more than one entry?

- **Yes:** Continue with the next step.
  - **No:** Go to step 32 on page 55.
- 

26. Is the error class recorded in step 25 AIX?

- **Yes:** Continue with the next step.
  - **No:** Go to step 32 on page 55.
- 

27. Perform all the following steps for each entry in the list of all partitions you recorded in step 11 on page 53, except for the partition you were using to debug the original problem.

---

28. From the list of all partitions, open the HMC virtual terminal window of a partition, and then type `diag` at the AIX command prompt.

---

29. When the diagnostic operating instructions are displayed, complete the following steps:

1. Press Enter.
2. Select the **Task Selection** option.
3. Select the **Log Repair** option.
4. Select the resource associated with the repair action:
  - If the repair action was reseating a cable or adapter, select the resource associated with that repair action.
  - If the resource associated with your repair action is not displayed on the Resource List, select **sysplanar0**.
5. Click **Commit** after you make your selection.

**Note:** If the terminal type is not defined, you are prompted to define it before you can proceed.

---

30. Exit from diagnostics in this partition and return to the AIX command prompt.

---

31. Have all the partitions in the list of all the partitions you recorded in step 11 on page 53 been processed?

- **Yes:** Continue with the next step.
  - **No:** Go to step 24 on page 54 to process the next partition in the list you recorded in step 11 on page 53.
- 

32. Have all the serviceable events recorded in step 4 on page 52 been processed?

- **Yes:** Continue with the next step.
  - **No:** Go to step 5 on page 52 and process the next service action event in the list of serviceable events recorded in step 4 on page 52.
- 

33. While processing all service action events, were you directed to step 14 on page 53?

- **Yes:** Continue with the next step.
  - **No:** If the system attention LED is still on, turn off the LED as described in “Activating and deactivating LEDs” on page 64. Return the system to the customer. **This completes the repair.**  
**Note:** If, during the processing of the list of open service action events, some service action events remained open, further service actions might be required to complete the repair.
- 

34. Perform all the following steps for each entry in the list of Axx partitions you began recording in step 14 on page 53, except for the partition you were using to debug the original problem.

---

35. From the list of Axx partitions, open the management console virtual terminal window of a partition , and then type diag at the AIX command prompt.

---

36. When the diagnostic operating instructions are displayed, complete the following steps:

1. Press Enter.
  2. Select the **Task Selection** option.  
**Note:** If the terminal type is not defined, you are prompted to define it before you can proceed.
  3. Select the resource associated with the repair action:
    - If the repair action was reseating a cable or adapter, select the resource associated with that repair action.
    - If the resource associated with your repair action is not displayed on the Resource List, select **sysplanar0**.
  4. Click **Commit** after you make your selection.
- 

37. Exit from diagnostics in this partition and return to the AIX command prompt.

---

38. Have all the partitions in the list of Axx partitions you began recording in step 14 on page 53 been processed?

- **Yes:** Continue with the next step.
  - **No:** Go to step 34 to process the next partition in the list you recorded in step 14 on page 53.
- 

39. If the system attention LED is still on, turn off the LED as described in “Activating and deactivating LEDs” on page 64. **This completes the repair.** Return the system to the customer.

**Note:** If, during the processing of the list of open service action events, some service action events remained open, further service actions might be required to complete the repair.

---

## Closing a service call by using AIX or Linux

If the server is not connected to a management console and not using Integrated Virtualization Manager (IVM), perform these procedures to close serviceable events, clear hardware messages, and prepare the server to return to the customer.

Follow this checklist before performing the procedure:

- Return the server to the state that the customer normally uses, such as IPL type, IPL mode, and the way the system is configured or partitioned.

**Attention:** Before returning the system to the customer, remove the system from service mode. If the system is left in service mode, it automatically places a call for service every two hours.

- While you were performing the problem analysis on the original serviceable event, other serviceable-event numbers might have been opened. Close all serviceable events that were opened as a result of your service activity.
- Ensure that server verification has been performed and that no problems require additional service actions.
- If the repair was done by using the IVM online repair procedures, ensure that the original serviceable event is now closed.

1. Did you use a hot-swap operation by using an AIX diagnostics service aid to change the FRU?

- **Yes:** Go to step 4
  - **No:** Continue with the next step.
- 

2. Do you have any field-replaceable units (FRUs) (for example cards, adapters, cables, or devices) that were removed during problem analysis that you want to put back into the system?

**Note:** If the system backplane or battery has been replaced and you are loading diagnostics from a server over a network, it might be necessary for the customer to set the network boot information for this system before diagnostics can be loaded. Also, set the system time and date information after the repair is completed.

- **Yes:** Reinstall all of the FRUs that were removed during problem analysis. Go to step 3
  - **No:** Continue with the next step.
- 

3. Is the system or logical partition that you are performing a repair action on running the AIX operating system?

- **Yes:** Continue with the next step.
  - **No:** Go to step 5 on page 57.
- 

4. Does the system or logical partition you are performing a repair action on have the AIX operating system installed?

**Note:** If you have just replaced a hard disk in the root volume group, answer no to this question.

- **Yes:** Go to step 7 on page 57.
  - **No:** Continue with the next step.
-

5. Run stand-alone diagnostics in problem determination mode from either a CD-ROM or from a Network Installation Management (NIM) server.

**Note:** For instructions about running stand-alone diagnostics from a CD and not by using an HMC, go to Running the stand-alone diagnostics from CD on a server without an HMC attached.

For instructions about running stand-alone diagnostics from a NIM server, go to Running the stand-alone diagnostics from a Network Installation Management server.

Did you encounter any problems?

- **Yes:** Go to Problem analysis.
  - **No:** Continue with the next step.
- 

6. The system hardware is functioning correctly.

If the system attention LED is still on, turn off the LED as described in “Activating and deactivating LEDs” on page 64.

**This completes the repair.**

**Note:** If, during the processing of the list of open service action events, some service action events remained open, further service actions might be required to complete the repair.

Return the server to the state that the customer normally uses, such as IPL type, IPL mode, and the way the system is configured or partitioned. This might require you to reboot the operating system.

**Attention:** Before returning the system to the customer, remove the system from service mode. If the system is left in service mode, it automatically places a call for service every two hours.

---

7. Complete the following steps:

1. If the system supports, do a slow boot on the system. For instructions, see Performing a slow boot. If the system does not support a slow boot, do a normal boot.
2. Power on the system.
3. Wait until the AIX operating system login prompt is displayed or until system activity on the operator panel or display has stopped.

Did the AIX Login Prompt display?

- **Yes:** Continue with the next step.
  - **No:** Go to Problem analysis.
- 

8. If the Resource Repair Action menu is already displayed, go to 12 on page 58; otherwise, complete the following steps:

1. Log into the operating system, either with root authority (if needed, ask the customer to enter the password) or use the CE login.
  2. Enter the `diag -a` command and check for missing resources. Follow any instructions that are displayed. If a system request number (SRN) is displayed, suspect a loose card or connection. If no instructions are displayed, no resources were detected as missing. Continue with step 9.
- 

9. Complete the following steps:

1. Enter `diag` at the command prompt and press **Enter**.
2. Select the **Diagnostics Routines** option.
3. When the Diagnostic Mode Selection menu is displayed, select **Problem determination**.
4. When the Advanced Diagnostic Selection menu is displayed, select the **All Resources** option. Alternatively, test the FRUs you exchanged and any devices that are attached to the FRUs you exchanged by selecting the diagnostics for the individual FRU.

Did the Resource Repair Action menu (801015) display?

- **Yes:** Go to step 13 on page 59.
  - **No:** Continue with the next step.
- 

10. Did the TESTING COMPLETE, no trouble was found menu (801010) display?

- **Yes:** Continue with the next step.
  - **No:** There is still a problem. Go to Problem analysis.
- 

11. Select the **Log Repair Action** option, if not previously logged, in the TASK SELECTION menu to update the AIX error log. If the repair action was reseating a cable or adapter, select the resource associated with that repair action.

If the resource associated with your action is not displayed on the resource list, select **sysplanar0**.

**Note:** If the system attention indicator is on, this will set it back to the normal state. Go to step 14 on page 59.

---

12. Run a test on a resource that has an entry in the AIX error log, in the system verification mode. If the test on the resource was successful, the Resource Repair Action menu is displayed.

After replacing a FRU, select the resource for that FRU from the Resource Repair Action menu. This updates the AIX error log to indicate that a system-detectable FRU has been replaced.

**Note:** If the system attention indicator is on, this action will set it back to the normal state.

To select the resource for the replaced FRU, complete the following steps:

1. Select the resource associated with the repair action:
  - If the repair action was reseating a cable or adapter, select the resource associated with that repair action.
  - If the resource associated with your repair action is not displayed on the Resource List, select **sysplanar0**.
2. Click **Commit** after you make your selection.

Did another Resource Repair Action (801015) display?

- **Yes:** Continue with the next step.
  - **No:** If the No Trouble Found menu is displayed, go to step 14.
- 

### 13.

Run a test on a resource that has an entry in the AIX error log, in the system verification mode. If the test on the resource was successful, the Resource Repair Action menu is displayed.

**Note:** The parent or child of the resource you just replaced might also require that you run the Resource Repair Action service aid on it.

After replacing that FRU, select the resource for that FRU from the Resource Repair Action menu. This updates the AIX error log to indicate that a system-detectable FRU has been replaced.

**Note:** If the system attention indicator is on, this action will set it back to the normal state.

To select the resource for the replaced FRU, complete the following steps:

1. Select the resource associated with the repair action:
  - If the repair action was reseating a cable or adapter, select the resource associated with that repair action.
  - If the resource associated with your repair action is not displayed on the Resource List, select **sysplanar0**.
2. Click **Commit** after you make your selection.

Did the No Trouble Found menu display?

- **Yes:** Continue with the next step.
  - **No:** Go to Problem analysis.
- 

14. If you changed the service processor or network settings, as instructed in previous MAPs, restore the settings to the value they had prior to servicing the system. If you ran stand-alone diagnostics from CD-ROM, remove the stand-alone diagnostics CD-ROM from the system.

Did you perform service on a RAID subsystem that involved changing the PCI RAID adapter cache card or changing the configuration?

**Note:** This does not refer to the PCI-X RAID adapter or cache.

- **Yes:** Continue with the next step.
  - **No:** Go to step 16 on page 60.
- 

15. Use the **Recover Options** selection to resolve the RAID configuration. To do this, complete the following steps:

1. On the PCI SCSI Disk Array Manager dialog, select **Recovery options**.
  2. Select **Clear PCI SCSI Adapter Configuration** and press F3 to clear any previous configuration data that exists on the replacement adapter.
  3. On the Recovery Options dialog, select **Resolve PCI SCSI RAID Adapter Configuration**.
  4. On the Resolve PCI SCSI RAID Adapter Configuration dialog, select **Accept Configuration on Drives**.
  5. On the PCI SCSI RAID Adapter selections menu, select the adapter that you changed.
  6. On the next dialog, press Enter.
  7. When you see the Are You Sure selection menu, press Enter to continue. When the recovery action is complete, the status message of **OK** is shown.
  8. If you receive a status message of **Failed**, verify that you selected the correct adapter, and then repeat this procedure. When recovery is complete, exit the operating system.
  9. Go to step 16.
- 

16. The system hardware is functioning correctly. Return the server to the state that the customer normally uses, such as IPL type, IPL mode, and the way the system is configured or partitioned.

**Attention:** Before returning the system to the customer, remove the system from service mode. If the system is left in service mode, it automatically places a call for service every two hours.

---

## Closing a service call by using Integrated Virtualization Manager

Perform these procedures to close serviceable events, clear hardware messages, and prepare the server to return to the customer.

Follow this checklist before performing the procedure:

- Return the server to the state that the customer normally uses, such as IPL type, IPL mode, and the way the system is configured or partitioned.

**Attention:** Before returning the system to the customer, remove the system from service mode. If the system is left in service mode, it automatically places a call for service every two hours.

- While you were performing the problem analysis on the original serviceable event, other serviceable-event numbers might have been opened. Close all serviceable events that were opened as a result of your service activity.
  - Ensure that server verification has been performed and there are no problems that require additional service actions.
  - If the repair was done by using the Integrated Virtualization Manager (IVM) online repair procedures, ensure that the original serviceable event is now closed.
    1. Record the system reference code (SRC), or symptom, and the location code of the field-replaceable unit (FRU) you replaced for future reference.
- 

2. On the IVM, open **Manage Serviceable Events** and look at existing serviceable events.
- 

3. Are there any service action events that are open?

- **Yes:** Continue with the next step.
  - **No:** If the system attention LED is still on, turn off the LED as described in “Activating and deactivating LEDs” on page 64. Return the system to the customer. **This completes the repair.**
- 

4. Record the list of open service action events.



---

5. From the list of serviceable events recorded in step 4 on page 60, complete steps 6 - 30 on page 63 for each open service action event.

---

6. Determine the error class of the serviceable event. Record it for future use.

---

7. Examine the details of the open service action event.

Is the error code associated with this service action event the same as recorded in step 1 on page 60?

- **Yes:** Go to step 11.
  - **No:** Continue with the next step.
- 

8. Examine the FRU list of the service action event. Are any FRUs listed for the service action event?

- **Yes:** Continue with the next step.
  - **No:** Go to step 11.
- 

9. Is the FRU list identical that is, the same FRUs, same number of FRUs, and same order of FRUs) to the FRU list of the error code recorded in step 1 on page 60?

- **Yes:** Go to step 11.
  - **No:** Continue with the next step.
- 

10. Is the FRU you replaced and recorded in step 1 on page 60 in the list of FRUs for this service action event?

- **Yes:** Continue with the next step.
- **No:** Go to step 30 on page 63.

**Note:** Some service action events remain open when you leave this MAP. Further service actions might be required to complete the repair.

---

11. Examine the details of this service action event, and record the partitions involved in this service action event for use in a later step.

---

12. Is the error code associated with this service action event of the form A11-xxx or A01-xxx?

- **Yes:** Continue with the next step.
  - **No:** Go to step 17 on page 62.
- 

13. Have you begun a list of Axx partitions from prior service action events that you processed in this maintenance analysis procedure (MAP)?

- **Yes:** Go to step 15 on page 62.
  - **No:** Continue with the next step.
-

14. Begin a new list of Axx partitions by copying the list of partitions obtained in step 11 on page 61. Go to step 16.

---

15. Add the partition list obtained in step 11 on page 61 to the existing list of Axx partitions obtained from processing previous service action events in this MAP.

---

16. Remove all entries in the list of all partitions you recorded in step 11 on page 61. If you are referred to the list of partitions obtained in step 11 on page 61 in future steps, the list is empty. Go to step 17.

---

17. Select and highlight the service action event from the Manage Serviceable Events window.

---

18. Click **Close Event**.

---

19. Add comments for the serviceable event. Include any unique additional information. Click **OK**.

---

20. Add or update the FRU information:

Did you replace, add, or modify a FRU of the open service action event?

- **Yes:** Continue with the next step.
  - **No:** Go to step 22.
- 

21. Click **OK** to close the service action event.

---

22. Is the list of all partitions you recorded in step 11 on page 61 empty?

- **Yes:** Go to step 30 on page 63.
  - **No:** Continue with the next step.
- 

23. Does the list of all partitions you recorded in step 11 on page 61 contain more than one entry?

- **Yes:** Continue with the next step.
  - **No:** Go to step 30 on page 63.
- 

24. Is the error class recorded in step 23?

- **Yes:** Continue with the next step.
  - **No:** Go to step 30 on page 63.
- 

25. Perform all the following steps for each entry in the list of all partitions you recorded in step 11 on page 61, except for the partition you were using to debug the original problem.

**62** Power Systems: Vital product data card for the 8233-E8B or 8236-E8C

---

26. From the list of all partitions, open the IVM virtual terminal window of a partition, and then type `diag` at the AIX command prompt.

---

27. When the diagnostic operating instructions are displayed, complete the following steps:

1. Press Enter.
2. Select the **Task Selection** option.
3. Select the **Log Repair** option.
4. Select the resource associated with the repair action:
  - If the repair action was reseating a cable or adapter, select the resource associated with that repair action.
  - If the resource associated with your repair action is not displayed on the Resource List, select **sysplanar0**.
5. Click **Commit** after you make your selection.

**Note:** If the terminal type is not defined, you are prompted to define it before you can proceed.

---

28. Exit from diagnostics in this partition and return to the AIX command prompt.

---

29. Have all the partitions in the list of all partitions you recorded in step 11 on page 61 been processed?

- **Yes:** Continue with the next step.
  - **No:** Go to step 25 on page 62 to process the next partition in the list you recorded in step 11 on page 61.
- 

30. Have all the serviceable events recorded in step 4 on page 60 been processed?

- **Yes:** Continue with the next step.
  - **No:** Go to step 5 on page 61 and process the next service action event in the list of serviceable events recorded in step 4 on page 60.
- 

31. While processing all service action events, were you directed to step 14 on page 62?

- **Yes:** Continue with the next step.
  - **No:** If the system attention LED is still on, turn off the LED as described in “Activating and deactivating LEDs” on page 64. Return the system to the customer. **This completes the repair.**  
**Note:** If during the processing of the list of open service action events, some service action events remained open, further service actions might be required to complete the repair.
- 

32. Complete all the following steps for each entry in the list of `Axx` partitions you began recording in step 14 on page 62, except for the partition you were using to debug the original problem.

---

33. From the list of `Axx` partitions, open the management console virtual terminal window of a partition , and then type `diag` at the AIX command prompt.

---

34. When the diagnostic operating instructions are displayed, complete the following steps:

1. Press Enter.
  2. Select the **Task Selection** option.  
**Note:** If the terminal type is not defined, you are prompted to define it before you can proceed.
  3. Select the **Log Repair** option.
  4. Select the resource associated with the repair action:
    - If the repair action was reseating a cable or adapter, select the resource associated with that repair action.
    - If the resource associated with your repair action is not displayed on the Resource List, select **sysplanar0**.
  5. Click **Commit** after you make your selection.
- 

35. Exit from diagnostics in this partition and return to the AIX command prompt.

---

36. Have all the partitions in the list of Axx partitions you began recording in step 14 on page 62 been processed?

- **Yes:** Continue with the next step.
  - **No:** Go to step 32 on page 63 to process the next partition in the list you recorded in step 14 on page 62.
- 

37. If the system attention LED is still on, turn off the LED as described in “Activating and deactivating LEDs.” **This completes the repair.** Return the system to the customer.

**Note:** If, during the processing of the list of open service action events, some service action events remained open, further service actions might be required to complete the repair.

---

## Activating and deactivating LEDs

You can use these procedures to activate or deactivate light-emitting diodes (LEDs) by using the management console or the Advanced System Management Interface (ASMI).

The system attention LED is activated when an error that requires a service action is detected, but a fault LED is not activated. Such errors can include errors that generate a system reference code (SRC) or a service request number (SRN). On systems that support fault LEDs, a fault LED is activated for many problems that can be isolated to a specific hardware component. However, for some problems that require a service action, a fault LED might not be activated even if a problem can be isolated to a specific hardware component. For those problems, the system attention LED is activated instead.

For IBM Power Systems servers that contain the POWER7 processor, the LEDs can be used to identify or verify a part that you are servicing. The error and identify function (amber) LED indicates an error and corresponds to the location code in the system reference code (SRC). The LED is activated and deactivated automatically.

Additionally, the following procedures can also be used to activate and deactivate LEDs.

- “Deactivating a system attention LED or partition LED by using the management console” on page 65
- “Activating or deactivating an identify LED by using the management console” on page 65
- “Deactivating a system attention LED or logical partition LED by using the Advanced System Management Interface” on page 66
- “Activating or deactivating an identify LED by using the Advanced System Management Interface” on page 67

## Deactivating a system attention LED or partition LED by using the management console

You can deactivate a system attention LED or a logical partition LED if you decide that a problem is not a high priority and you decide to repair the problem at a later time. You can do this task from the Hardware Management Console (HMC) or the IBM Systems Director Management Console (SDMC).

If you want to be alerted if another problem occurs, you must deactivate the system attention LED so that it can be activated again if another problem occurs.

To deactivate a system attention LED by using the HMC, complete the following steps:

1. In the navigation area, open **Systems management**.
2. Select the server that you are working on.
3. Open **Operations > LED Status**.
4. Select **View System Attention**. The System attention LED window opens. The selected system and its LED state are displayed in the upper part of the window. The logical partition and its LED state are displayed in the lower part of the window. From the system attention LED window, you can deactivate both the System attention LED and the logical partition LED.
5. Select **Deactivate System Attention LED** from the **Action** menu. A confirmation window is displayed that provides the following information:
  - A verification that the system attention LED was deactivated.
  - An indication that there still might be open problems within the system.
  - An indication that you cannot activate the system attention LED.
6. Select one of the logical partitions in the lower table, and select **Deactivate partition LED** from the **Partition Operations** menu. A confirmation window is displayed that provides the following information:
  - A verification that the logical partition LED was deactivated.
  - An indication that there still might be open problems within the logical partition.
  - An indication that you cannot activate the logical partition LED.

To deactivate a system attention LED by using the SDMC, complete the following steps:

1. On the **Welcome** page, under the **Resources** tab, select the server.
2. Click **Actions > Service and Support > Hardware > System Attention LED**.
3. Click **OK**.

## Activating or deactivating an identify LED by using the management console

You can activate or deactivate an identify LED for components attached to the system from the Hardware Management Console (HMC) or from the IBM Systems Director Management Console (SDMC).

The system provides several LEDs that help identify various components in the system, such as enclosures or field-replaceable units (FRUs). For this reason, the LEDs are called *identify LEDs*.

You can activate or deactivate the following types of identify LEDs:

- **Identify LED for an enclosure.** If you want to add an adapter to a specific drawer (enclosure), you need to know the machine type, model, and serial number (MTMS) of the drawer. To determine whether you have the correct MTMS for the drawer that needs the new adapter, you can activate the LED for a drawer and verify that the MTMS corresponds to the drawer that requires the new adapter.

- **Identify LED for a FRU associated with a specified enclosure.** If you want to hook up a cable to a specific I/O adapter, you can activate the LED for the adapter, which is a field replaceable unit (FRU), and then physically check to see where you should connect the cable. This is especially useful when you have several adapters with open ports.

To activate or deactivate an identify LED for an enclosure or FRU by using the HMC, follow these steps:

1. In the navigation area, open **Systems management**.
2. Select the server you are working on.
3. Click **Operations > LED Status > Identify LED**. The Identify LED, Select Enclosure window opens.
4. To activate or deactivate an identify LED for an enclosure, select an enclosure from the table, and click either **Activate LED** or **Deactivate LED**. The associated LED is either turned on or off.
5. To activate or deactivate an identify LED for a FRU, select an enclosure from the table, and then select **Selected > List FRUs**.
6. Select one or more FRUs from the table, and click either **Activate LED** or **Deactivate LED**. The associated LED is either turned on or off.

To activate or deactivate an identify LED for an enclosure or FRU by using the SDMC, complete these steps:

1. On the **Welcome** page, under the **Resources** tab, select the server.
2. Click **Actions > Service and Support > Hardware > Identify LED**.
3. To activate or deactivate an identify LED for an enclosure, select an enclosure from the table, and click either **Activate LED** or **Deactivate LED**. The associated LED is either turned on or off.
4. To activate or deactivate an identify LED for a FRU, select an enclosure from the table, and then click **List FRUs**.
5. Select one or more FRUs from the table, and then click either **Activate LED** or **Deactivate LED**. The associated LED is either turned on or off.

## Deactivating a system attention LED or logical partition LED by using the Advanced System Management Interface

You can deactivate a system attention LED or a logical partition LED by using the Advanced System Management Interface (ASMI).

The system attention indicator provides a visual signal that the system as a whole requires attention or service. Each system has a single system attention indicator. When an event occurs that either needs your intervention or that of service and support, the system attention indicator lights continuously. The system attention indicator is turned on when an entry is made in the service processor error log. The error entry is transmitted to the system error log and to the operating system error log.

To perform this operation, your authority level must be one of the following levels:

- Administrator
- Authorized service provider

To turn off the system attention indicator, do the following steps:

1. In the ASMI Welcome pane, specify your user ID and password, and click **Log In**.
2. In the navigation area, expand **System Configuration > Service Indicators > System Attention Indicator**.
3. In the right pane, click **Turn off system attention indicator**. If the attempt is unsuccessful, an error message is displayed.

## Activating or deactivating an identify LED by using the Advanced System Management Interface

You can activate or deactivate an identify LED by using the Advanced System Management Interface (ASMI).

You can specify the location code of any indicator to view or modify its current state. If you provide the wrong location code, the advanced system manager attempts to go to the next higher level of the location code.

The next level is the base-level location code for that field replaceable unit (FRU). For example, a user types the location code for the FRU located on the second I/O slot of the third enclosure in the system. If the location code for the second I/O slot is incorrect (the FRU does not exist at this location), an attempt to set the indicator for the third enclosure is initiated. This process continues until a FRU is located or no other level is available.

To perform this operation, your authority level must be one of the following levels:

- Administrator
- Authorized service provider

To change the current state of an indicator, do the following steps:

1. On the ASMI Welcome pane, specify your user ID and password, and click **Log In**.
2. In the navigation area, expand **System Configuration > Service Indicators > Indicators by Location code**.
3. In the right pane, enter the location code of the FRU and click **Continue**.
4. Select the preferred state from the list.
5. Click **Save settings**.





---

## Notices

This information was developed for products and services offered in the U.S.A.

The manufacturer may not offer the products, services, or features discussed in this document in other countries. Consult the manufacturer's representative for information on the products and services currently available in your area. Any reference to the manufacturer's product, program, or service is not intended to state or imply that only that product, program, or service may be used. Any functionally equivalent product, program, or service that does not infringe any intellectual property right of the manufacturer may be used instead. However, it is the user's responsibility to evaluate and verify the operation of any product, program, or service.

The manufacturer may have patents or pending patent applications covering subject matter described in this document. The furnishing of this document does not grant you any license to these patents. You can send license inquiries, in writing, to the manufacturer.

**The following paragraph does not apply to the United Kingdom or any other country where such provisions are inconsistent with local law:** THIS PUBLICATION IS PROVIDED "AS IS" WITHOUT WARRANTY OF ANY KIND, EITHER EXPRESS OR IMPLIED, INCLUDING, BUT NOT LIMITED TO, THE IMPLIED WARRANTIES OF NON-INFRINGEMENT, MERCHANTABILITY OR FITNESS FOR A PARTICULAR PURPOSE. Some states do not allow disclaimer of express or implied warranties in certain transactions, therefore, this statement may not apply to you.

This information could include technical inaccuracies or typographical errors. Changes are periodically made to the information herein; these changes will be incorporated in new editions of the publication. The manufacturer may make improvements and/or changes in the product(s) and/or the program(s) described in this publication at any time without notice.

Any references in this information to websites not owned by the manufacturer are provided for convenience only and do not in any manner serve as an endorsement of those websites. The materials at those websites are not part of the materials for this product and use of those websites is at your own risk.

The manufacturer may use or distribute any of the information you supply in any way it believes appropriate without incurring any obligation to you.

Any performance data contained herein was determined in a controlled environment. Therefore, the results obtained in other operating environments may vary significantly. Some measurements may have been made on development-level systems and there is no guarantee that these measurements will be the same on generally available systems. Furthermore, some measurements may have been estimated through extrapolation. Actual results may vary. Users of this document should verify the applicable data for their specific environment.

Information concerning products not produced by this manufacturer was obtained from the suppliers of those products, their published announcements or other publicly available sources. This manufacturer has not tested those products and cannot confirm the accuracy of performance, compatibility or any other claims related to products not produced by this manufacturer. Questions on the capabilities of products not produced by this manufacturer should be addressed to the suppliers of those products.

All statements regarding the manufacturer's future direction or intent are subject to change or withdrawal without notice, and represent goals and objectives only.

The manufacturer's prices shown are the manufacturer's suggested retail prices, are current and are subject to change without notice. Dealer prices may vary.

This information is for planning purposes only. The information herein is subject to change before the products described become available.

This information contains examples of data and reports used in daily business operations. To illustrate them as completely as possible, the examples include the names of individuals, companies, brands, and products. All of these names are fictitious and any similarity to the names and addresses used by an actual business enterprise is entirely coincidental.

If you are viewing this information in softcopy, the photographs and color illustrations may not appear.

The drawings and specifications contained herein shall not be reproduced in whole or in part without the written permission of the manufacturer.

The manufacturer has prepared this information for use with the specific machines indicated. The manufacturer makes no representations that it is suitable for any other purpose.

The manufacturer's computer systems contain mechanisms designed to reduce the possibility of undetected data corruption or loss. This risk, however, cannot be eliminated. Users who experience unplanned outages, system failures, power fluctuations or outages, or component failures must verify the accuracy of operations performed and data saved or transmitted by the system at or near the time of the outage or failure. In addition, users must establish procedures to ensure that there is independent data verification before relying on such data in sensitive or critical operations. Users should periodically check the manufacturer's support websites for updated information and fixes applicable to the system and related software.

## **Homologation statement**

This product may not be certified in your country for connection by any means whatsoever to interfaces of public telecommunications networks. Further certification may be required by law prior to making any such connection. Contact an IBM representative or reseller for any questions.

---

## **Trademarks**

IBM, the IBM logo, and [ibm.com](http://ibm.com) are trademarks or registered trademarks of International Business Machines Corp., registered in many jurisdictions worldwide. Other product and service names might be trademarks of IBM or other companies. A current list of IBM trademarks is available on the web at [www.ibm.com/legal/copytrade.shtml](http://www.ibm.com/legal/copytrade.shtml).

Linux is a registered trademark of Linus Torvalds in the United States, other countries, or both.

---

## **Electronic emission notices**

When attaching a monitor to the equipment, you must use the designated monitor cable and any interference suppression devices supplied with the monitor.

## **Class A Notices**

The following Class A statements apply to the IBM servers that contain the POWER7 processor and its features unless designated as electromagnetic compatibility (EMC) Class B in the feature information.

## **Federal Communications Commission (FCC) statement**

**Note:** This equipment has been tested and found to comply with the limits for a Class A digital device, pursuant to Part 15 of the FCC Rules. These limits are designed to provide reasonable protection against harmful interference when the equipment is operated in a commercial environment. This equipment generates, uses, and can radiate radio frequency energy and, if not installed and used in accordance with

the instruction manual, may cause harmful interference to radio communications. Operation of this equipment in a residential area is likely to cause harmful interference, in which case the user will be required to correct the interference at his own expense.

Properly shielded and grounded cables and connectors must be used in order to meet FCC emission limits. IBM is not responsible for any radio or television interference caused by using other than recommended cables and connectors or by unauthorized changes or modifications to this equipment. Unauthorized changes or modifications could void the user's authority to operate the equipment.

This device complies with Part 15 of the FCC rules. Operation is subject to the following two conditions: (1) this device may not cause harmful interference, and (2) this device must accept any interference received, including interference that may cause undesired operation.

### **Industry Canada Compliance Statement**

This Class A digital apparatus complies with Canadian ICES-003.

### **Avis de conformité à la réglementation d'Industrie Canada**

Cet appareil numérique de la classe A est conforme à la norme NMB-003 du Canada.

### **European Community Compliance Statement**

This product is in conformity with the protection requirements of EU Council Directive 2004/108/EC on the approximation of the laws of the Member States relating to electromagnetic compatibility. IBM cannot accept responsibility for any failure to satisfy the protection requirements resulting from a non-recommended modification of the product, including the fitting of non-IBM option cards.

This product has been tested and found to comply with the limits for Class A Information Technology Equipment according to European Standard EN 55022. The limits for Class A equipment were derived for commercial and industrial environments to provide reasonable protection against interference with licensed communication equipment.

European Community contact:  
IBM Deutschland GmbH  
Technical Regulations, Department M372  
IBM-Allee 1, 71139 Ehningen, Germany  
Tele: +49 7032 15 2941  
email: lugi@de.ibm.com

**Warning:** This is a Class A product. In a domestic environment, this product may cause radio interference, in which case the user may be required to take adequate measures.

### **VCCI Statement - Japan**

この装置は、クラスA 情報技術装置です。この装置を家庭環境で使用すると電波妨害を引き起こすことがあります。この場合には使用者が適切な対策を講ずるよう要求されることがあります。

VCCI-A

The following is a summary of the VCCI Japanese statement in the box above:

This is a Class A product based on the standard of the VCCI Council. If this equipment is used in a domestic environment, radio interference may occur, in which case, the user may be required to take corrective actions.

### **Japanese Electronics and Information Technology Industries Association (JEITA) Confirmed Harmonics Guideline (products less than or equal to 20 A per phase)**

高調波ガイドライン適合品

### **Japanese Electronics and Information Technology Industries Association (JEITA) Confirmed Harmonics Guideline with Modifications (products greater than 20 A per phase)**

高調波ガイドライン準用品

### **Electromagnetic Interference (EMI) Statement - People's Republic of China**

#### **声 明**

此为 A 级产品,在生活环境中,  
该产品可能会造成无线电干扰。  
在这种情况下,可能需要用户对其  
干扰采取切实可行的措施。

Declaration: This is a Class A product. In a domestic environment this product may cause radio interference in which case the user may need to perform practical action.

### **Electromagnetic Interference (EMI) Statement - Taiwan**

#### **警告使用者：**

這是甲類的資訊產品，在  
居住的環境中使用時，可  
能會造成射頻干擾，在這  
種情況下，使用者會被要  
求採取某些適當的對策。

The following is a summary of the EMI Taiwan statement above.

Warning: This is a Class A product. In a domestic environment this product may cause radio interference in which case the user will be required to take adequate measures.

#### **IBM Taiwan Contact Information:**

台灣IBM 產品服務聯絡方式：  
台灣國際商業機器股份有限公司  
台北市松仁路7號3樓  
電話：0800-016-888

### **Electromagnetic Interference (EMI) Statement - Korea**

이 기기는 업무용(A급)으로 전자파적합기기로서 판매자 또는 사용자는 이 점을 주의하시기 바라며, 가정외의 지역에서 사용하는 것을 목적으로 합니다.

### **Germany Compliance Statement**

#### **Deutschsprachiger EU Hinweis: Hinweis für Geräte der Klasse A EU-Richtlinie zur Elektromagnetischen Verträglichkeit**

Dieses Produkt entspricht den Schutzanforderungen der EU-Richtlinie 2004/108/EG zur Angleichung der Rechtsvorschriften über die elektromagnetische Verträglichkeit in den EU-Mitgliedsstaaten und hält die Grenzwerte der EN 55022 Klasse A ein.

Um dieses sicherzustellen, sind die Geräte wie in den Handbüchern beschrieben zu installieren und zu betreiben. Des Weiteren dürfen auch nur von der IBM empfohlene Kabel angeschlossen werden. IBM übernimmt keine Verantwortung für die Einhaltung der Schutzanforderungen, wenn das Produkt ohne Zustimmung von IBM verändert bzw. wenn Erweiterungskomponenten von Fremdherstellern ohne Empfehlung von IBM gesteckt/eingebaut werden.

EN 55022 Klasse A Geräte müssen mit folgendem Warnhinweis versehen werden:

"Warnung: Dieses ist eine Einrichtung der Klasse A. Diese Einrichtung kann im Wohnbereich Funk-Störungen verursachen; in diesem Fall kann vom Betreiber verlangt werden, angemessene Maßnahmen zu ergreifen und dafür aufzukommen."

#### **Deutschland: Einhaltung des Gesetzes über die elektromagnetische Verträglichkeit von Geräten**

Dieses Produkt entspricht dem "Gesetz über die elektromagnetische Verträglichkeit von Geräten (EMVG)". Dies ist die Umsetzung der EU-Richtlinie 2004/108/EG in der Bundesrepublik Deutschland.

#### **Zulassungsbescheinigung laut dem Deutschen Gesetz über die elektromagnetische Verträglichkeit von Geräten (EMVG) (bzw. der EMC EG Richtlinie 2004/108/EG) für Geräte der Klasse A**

Dieses Gerät ist berechtigt, in Übereinstimmung mit dem Deutschen EMVG das EG-Konformitätszeichen - CE - zu führen.

Verantwortlich für die Einhaltung der EMV Vorschriften ist der Hersteller:  
International Business Machines Corp.  
New Orchard Road  
Armonk, New York 10504  
Tel: 914-499-1900

Der verantwortliche Ansprechpartner des Herstellers in der EU ist:  
IBM Deutschland GmbH  
Technical Regulations, Abteilung M372  
IBM-Allee 1, 71139 Ehningen, Germany  
Tel: +49 7032 15 2941  
email: lugi@de.ibm.com

Generelle Informationen:

Das Gerät erfüllt die Schutzanforderungen nach EN 55024 und EN 55022 Klasse A.

### **Electromagnetic Interference (EMI) Statement - Russia**

**ВНИМАНИЕ!** Настоящее изделие относится к классу А.  
В жилых помещениях оно может создавать  
радиопомехи, для снижения которых необходимы  
дополнительные меры

### **Class B Notices**

The following Class B statements apply to features designated as electromagnetic compatibility (EMC) Class B in the feature installation information.

### **Federal Communications Commission (FCC) statement**

This equipment has been tested and found to comply with the limits for a Class B digital device, pursuant to Part 15 of the FCC Rules. These limits are designed to provide reasonable protection against harmful interference in a residential installation.

This equipment generates, uses, and can radiate radio frequency energy and, if not installed and used in accordance with the instructions, may cause harmful interference to radio communications. However, there is no guarantee that interference will not occur in a particular installation.

If this equipment does cause harmful interference to radio or television reception, which can be determined by turning the equipment off and on, the user is encouraged to try to correct the interference by one or more of the following measures:

- Reorient or relocate the receiving antenna.
- Increase the separation between the equipment and receiver.
- Connect the equipment into an outlet on a circuit different from that to which the receiver is connected.
- Consult an IBM-authorized dealer or service representative for help.

Properly shielded and grounded cables and connectors must be used in order to meet FCC emission limits. Proper cables and connectors are available from IBM-authorized dealers. IBM is not responsible for

any radio or television interference caused by unauthorized changes or modifications to this equipment. Unauthorized changes or modifications could void the user's authority to operate this equipment.

This device complies with Part 15 of the FCC rules. Operation is subject to the following two conditions: (1) this device may not cause harmful interference, and (2) this device must accept any interference received, including interference that may cause undesired operation.

### **Industry Canada Compliance Statement**

This Class B digital apparatus complies with Canadian ICES-003.

### **Avis de conformité à la réglementation d'Industrie Canada**

Cet appareil numérique de la classe B est conforme à la norme NMB-003 du Canada.

### **European Community Compliance Statement**

This product is in conformity with the protection requirements of EU Council Directive 2004/108/EC on the approximation of the laws of the Member States relating to electromagnetic compatibility. IBM cannot accept responsibility for any failure to satisfy the protection requirements resulting from a non-recommended modification of the product, including the fitting of non-IBM option cards.

This product has been tested and found to comply with the limits for Class B Information Technology Equipment according to European Standard EN 55022. The limits for Class B equipment were derived for typical residential environments to provide reasonable protection against interference with licensed communication equipment.

European Community contact:  
IBM Deutschland GmbH  
Technical Regulations, Department M372  
IBM-Allee 1, 71139 Ehningen, Germany  
Tele: +49 7032 15 2941  
email: lugi@de.ibm.com

### **VCCI Statement - Japan**

この装置は、クラスB情報技術装置です。この装置は、家庭環境で使用することを目的としていますが、この装置がラジオやテレビジョン受信機に近接して使用されると、受信障害を引き起こすことがあります。

取扱説明書に従って正しい取り扱いをして下さい。 VCCI-B

### **Japanese Electronics and Information Technology Industries Association (JEITA) Confirmed Harmonics Guideline (products less than or equal to 20 A per phase)**

高調波ガイドライン適合品

**Japanese Electronics and Information Technology Industries Association (JEITA)  
Confirmed Harmonics Guideline with Modifications (products greater than 20 A per  
phase)**

高調波ガイドライン準用品

**IBM Taiwan Contact Information**

台灣IBM 產品服務聯絡方式：  
台灣國際商業機器股份有限公司  
台北市松仁路7號3樓  
電話：0800-016-888

**Electromagnetic Interference (EMI) Statement - Korea**

이 기기는 가정용(B급)으로 전자과적합기기로  
서 주로 가정에서 사용하는 것을 목적으로 하  
며, 모든 지역에서 사용할 수 있습니다.

**Germany Compliance Statement**

**Deutschsprachiger EU Hinweis: Hinweis für Geräte der Klasse B EU-Richtlinie zur  
Elektromagnetischen Verträglichkeit**

Dieses Produkt entspricht den Schutzanforderungen der EU-Richtlinie 2004/108/EG zur Angleichung der Rechtsvorschriften über die elektromagnetische Verträglichkeit in den EU-Mitgliedsstaaten und hält die Grenzwerte der EN 55022 Klasse B ein.

Um dieses sicherzustellen, sind die Geräte wie in den Handbüchern beschrieben zu installieren und zu betreiben. Des Weiteren dürfen auch nur von der IBM empfohlene Kabel angeschlossen werden. IBM übernimmt keine Verantwortung für die Einhaltung der Schutzanforderungen, wenn das Produkt ohne Zustimmung von IBM verändert bzw. wenn Erweiterungskomponenten von Fremdherstellern ohne Empfehlung von IBM gesteckt/eingebaut werden.

**Deutschland: Einhaltung des Gesetzes über die elektromagnetische Verträglichkeit von Geräten**

Dieses Produkt entspricht dem "Gesetz über die elektromagnetische Verträglichkeit von Geräten (EMVG)". Dies ist die Umsetzung der EU-Richtlinie 2004/108/EG in der Bundesrepublik Deutschland.

**Zulassungsbescheinigung laut dem Deutschen Gesetz über die elektromagnetische Verträglichkeit von  
Geräten (EMVG) (bzw. der EMC EG Richtlinie 2004/108/EG) für Geräte der Klasse B**



Dieses Gerät ist berechtigt, in Übereinstimmung mit dem Deutschen EMVG das EG-Konformitätszeichen - CE - zu führen.

Verantwortlich für die Einhaltung der EMV Vorschriften ist der Hersteller:

International Business Machines Corp.

New Orchard Road

Armonk, New York 10504

Tel: 914-499-1900

Der verantwortliche Ansprechpartner des Herstellers in der EU ist:

IBM Deutschland GmbH

Technical Regulations, Abteilung M372

IBM-Allee 1, 71139 Ehningen, Germany

Tel: +49 7032 15 2941

email: lugi@de.ibm.com

Generelle Informationen:

**Das Gerät erfüllt die Schutzanforderungen nach EN 55024 und EN 55022 Klasse B.**

---

## Terms and conditions

Permissions for the use of these publications are granted subject to the following terms and conditions.

**Applicability:** These terms and conditions are in addition to any terms of use for the IBM website.

**Personal Use:** You may reproduce these publications for your personal, noncommercial use provided that all proprietary notices are preserved. You may not distribute, display or make derivative works of these publications, or any portion thereof, without the express consent of IBM.

**Commercial Use:** You may reproduce, distribute and display these publications solely within your enterprise provided that all proprietary notices are preserved. You may not make derivative works of these publications, or reproduce, distribute or display these publications or any portion thereof outside your enterprise, without the express consent of IBM.

**Rights:** Except as expressly granted in this permission, no other permissions, licenses or rights are granted, either express or implied, to the Publications or any information, data, software or other intellectual property contained therein.

IBM reserves the right to withdraw the permissions granted herein whenever, in its discretion, the use of the publications is detrimental to its interest or, as determined by IBM, the above instructions are not being properly followed.

You may not download, export or re-export this information except in full compliance with all applicable laws and regulations, including all United States export laws and regulations.

IBM MAKES NO GUARANTEE ABOUT THE CONTENT OF THESE PUBLICATIONS. THE PUBLICATIONS ARE PROVIDED "AS-IS" AND WITHOUT WARRANTY OF ANY KIND, EITHER EXPRESSED OR IMPLIED, INCLUDING BUT NOT LIMITED TO IMPLIED WARRANTIES OF MERCHANTABILITY, NON-INFRINGEMENT, AND FITNESS FOR A PARTICULAR PURPOSE.







Printed in USA