

Power Systems

*Installing the IBM Power 710 Express  
and the Power 730 Express  
(8231-E2B)*





Power Systems

*Installing the IBM Power 710 Express  
and the Power 730 Express  
(8231-E2B)*



**Note**

Before using this information and the product it supports, read the information in “Safety notices” on page v, “Notices” on page 35, the *IBM Systems Safety Notices* manual, G229-9054, and the *IBM Environmental Notices and User Guide*, Z125-5823.

This edition applies to IBM Power Systems servers that contain the POWER7 processor and to all associated models.

© Copyright IBM Corporation 2010, 2013.

US Government Users Restricted Rights – Use, duplication or disclosure restricted by GSA ADP Schedule Contract with IBM Corp.

---

# Contents

<b>Safety notices</b>	<b>v</b>
<b>Installing the IBM Power 710 Express and the IBM Power 730 Express (8231-E2B)</b>	<b>1</b>
Prerequisites for installing the 8231-E2B	1
Before you begin	1
Installation overview	2
<b>Installing the server into a rack</b>	<b>3</b>
Determining the location	3
Marking the location	4
Attaching the 8231-E2B mounting hardware to the rack	5
Installing the 8231-E2B system into the rack	8
Installing the cable-management arm	9
Connecting the expansion units, disk drives, and PCI adapters	13
<b>Cabling the server and setting up the console</b>	<b>15</b>
Cabling the server with an ASCII terminal	15
Cabling the server to the Hardware Management Console	16
Cabling the server and accessing the Integrated Virtualization Manager	17
Cabling the server with keyboard, video, and mouse	18
Connecting the power cables to the system	19
<b>Completing the server setup</b>	<b>21</b>
Completing the server setup by using Hardware Management Console	21
Completing the server setup without using a management console	23
<b>Reference information</b>	<b>25</b>
Installing rack-mounted and factory-racked servers	25
Installing the rack-mounted server	25
Installing the factory-racked server	26
Supporting information for setting up consoles	28
Accessing the ASMI using a web browser	28
Setting the IP address on your PC or notebook	29
Windows XP and Windows 2000	29
Windows Vista	30
Correcting an IP address	30
Common system attention LEDs and system reference codes	31
Best practices for integrating cable and system placement	32
<b>Notices</b>	<b>35</b>
Trademarks	36
Electronic emission notices	36
Class A Notices	36
Class B Notices	40
Terms and conditions	43



---

## Safety notices

Safety notices may be printed throughout this guide:

- **DANGER** notices call attention to a situation that is potentially lethal or extremely hazardous to people.
- **CAUTION** notices call attention to a situation that is potentially hazardous to people because of some existing condition.
- **Attention** notices call attention to the possibility of damage to a program, device, system, or data.

### World Trade safety information

Several countries require the safety information contained in product publications to be presented in their national languages. If this requirement applies to your country, safety information documentation is included in the publications package (such as in printed documentation, on DVD, or as part of the product) shipped with the product. The documentation contains the safety information in your national language with references to the U.S. English source. Before using a U.S. English publication to install, operate, or service this product, you must first become familiar with the related safety information documentation. You should also refer to the safety information documentation any time you do not clearly understand any safety information in the U.S. English publications.

Replacement or additional copies of safety information documentation can be obtained by calling the IBM Hotline at 1-800-300-8751.

### German safety information

Das Produkt ist nicht für den Einsatz an Bildschirmarbeitsplätzen im Sinne § 2 der Bildschirmarbeitsverordnung geeignet.

### Laser safety information

IBM® servers can use I/O cards or features that are fiber-optic based and that utilize lasers or LEDs.

#### Laser compliance

IBM servers may be installed inside or outside of an IT equipment rack.

## DANGER

When working on or around the system, observe the following precautions:

Electrical voltage and current from power, telephone, and communication cables are hazardous. To avoid a shock hazard:

- Connect power to this unit only with the IBM provided power cord. Do not use the IBM provided power cord for any other product.
- Do not open or service any power supply assembly.
- Do not connect or disconnect any cables or perform installation, maintenance, or reconfiguration of this product during an electrical storm.
- The product might be equipped with multiple power cords. To remove all hazardous voltages, disconnect all power cords.
- Connect all power cords to a properly wired and grounded electrical outlet. Ensure that the outlet supplies proper voltage and phase rotation according to the system rating plate.
- Connect any equipment that will be attached to this product to properly wired outlets.
- When possible, use one hand only to connect or disconnect signal cables.
- Never turn on any equipment when there is evidence of fire, water, or structural damage.
- Disconnect the attached power cords, telecommunications systems, networks, and modems before you open the device covers, unless instructed otherwise in the installation and configuration procedures.
- Connect and disconnect cables as described in the following procedures when installing, moving, or opening covers on this product or attached devices.

To Disconnect:

1. Turn off everything (unless instructed otherwise).
2. Remove the power cords from the outlets.
3. Remove the signal cables from the connectors.
4. Remove all cables from the devices.

To Connect:

1. Turn off everything (unless instructed otherwise).
2. Attach all cables to the devices.
3. Attach the signal cables to the connectors.
4. Attach the power cords to the outlets.
5. Turn on the devices.

(D005)

## DANGER



Observe the following precautions when working on or around your IT rack system:

- Heavy equipment—personal injury or equipment damage might result if mishandled.
- Always lower the leveling pads on the rack cabinet.
- Always install stabilizer brackets on the rack cabinet.
- To avoid hazardous conditions due to uneven mechanical loading, always install the heaviest devices in the bottom of the rack cabinet. Always install servers and optional devices starting from the bottom of the rack cabinet.
- Rack-mounted devices are not to be used as shelves or work spaces. Do not place objects on top of rack-mounted devices.



- Each rack cabinet might have more than one power cord. Be sure to disconnect all power cords in the rack cabinet when directed to disconnect power during servicing.
- Connect all devices installed in a rack cabinet to power devices installed in the same rack cabinet. Do not plug a power cord from a device installed in one rack cabinet into a power device installed in a different rack cabinet.
- An electrical outlet that is not correctly wired could place hazardous voltage on the metal parts of the system or the devices that attach to the system. It is the responsibility of the customer to ensure that the outlet is correctly wired and grounded to prevent an electrical shock.

#### CAUTION

- Do not install a unit in a rack where the internal rack ambient temperatures will exceed the manufacturer's recommended ambient temperature for all your rack-mounted devices.
- Do not install a unit in a rack where the air flow is compromised. Ensure that air flow is not blocked or reduced on any side, front, or back of a unit used for air flow through the unit.
- Consideration should be given to the connection of the equipment to the supply circuit so that overloading of the circuits does not compromise the supply wiring or overcurrent protection. To provide the correct power connection to a rack, refer to the rating labels located on the equipment in the rack to determine the total power requirement of the supply circuit.
- *(For sliding drawers.)* Do not pull out or install any drawer or feature if the rack stabilizer brackets are not attached to the rack. Do not pull out more than one drawer at a time. The rack might become unstable if you pull out more than one drawer at a time.
- *(For fixed drawers.)* This drawer is a fixed drawer and must not be moved for servicing unless specified by the manufacturer. Attempting to move the drawer partially or completely out of the rack might cause the rack to become unstable or cause the drawer to fall out of the rack.

(R001)

**CAUTION:**

Removing components from the upper positions in the rack cabinet improves rack stability during relocation. Follow these general guidelines whenever you relocate a populated rack cabinet within a room or building:

- Reduce the weight of the rack cabinet by removing equipment starting at the top of the rack cabinet. When possible, restore the rack cabinet to the configuration of the rack cabinet as you received it. If this configuration is not known, you must observe the following precautions:
  - Remove all devices in the 32U position and above.
  - Ensure that the heaviest devices are installed in the bottom of the rack cabinet.
  - Ensure that there are no empty U-levels between devices installed in the rack cabinet below the 32U level.
- If the rack cabinet you are relocating is part of a suite of rack cabinets, detach the rack cabinet from the suite.
- Inspect the route that you plan to take to eliminate potential hazards.
- Verify that the route that you choose can support the weight of the loaded rack cabinet. Refer to the documentation that comes with your rack cabinet for the weight of a loaded rack cabinet.
- Verify that all door openings are at least 760 x 230 mm (30 x 80 in.).
- Ensure that all devices, shelves, drawers, doors, and cables are secure.
- Ensure that the four leveling pads are raised to their highest position.
- Ensure that there is no stabilizer bracket installed on the rack cabinet during movement.
- Do not use a ramp inclined at more than 10 degrees.
- When the rack cabinet is in the new location, complete the following steps:
  - Lower the four leveling pads.
  - Install stabilizer brackets on the rack cabinet.
  - If you removed any devices from the rack cabinet, repopulate the rack cabinet from the lowest position to the highest position.
- If a long-distance relocation is required, restore the rack cabinet to the configuration of the rack cabinet as you received it. Pack the rack cabinet in the original packaging material, or equivalent. Also lower the leveling pads to raise the casters off of the pallet and bolt the rack cabinet to the pallet.

(R002)

(L001)



(L002)



(L003)



or



All lasers are certified in the U.S. to conform to the requirements of DHHS 21 CFR Subchapter J for class 1 laser products. Outside the U.S., they are certified to be in compliance with IEC 60825 as a class 1 laser product. Consult the label on each part for laser certification numbers and approval information.

**CAUTION:**

This product might contain one or more of the following devices: CD-ROM drive, DVD-ROM drive, DVD-RAM drive, or laser module, which are Class 1 laser products. Note the following information:

- Do not remove the covers. Removing the covers of the laser product could result in exposure to hazardous laser radiation. There are no serviceable parts inside the device.
- Use of the controls or adjustments or performance of procedures other than those specified herein might result in hazardous radiation exposure.

(C026)

**CAUTION:**

Data processing environments can contain equipment transmitting on system links with laser modules that operate at greater than Class 1 power levels. For this reason, never look into the end of an optical fiber cable or open receptacle. (C027)

**CAUTION:**

This product contains a Class 1M laser. Do not view directly with optical instruments. (C028)

**CAUTION:**

Some laser products contain an embedded Class 3A or Class 3B laser diode. Note the following information: laser radiation when open. Do not stare into the beam, do not view directly with optical instruments, and avoid direct exposure to the beam. (C030)

**CAUTION:**

The battery contains lithium. To avoid possible explosion, do not burn or charge the battery.

*Do Not:*

- \_\_\_ Throw or immerse into water
- \_\_\_ Heat to more than 100°C (212°F)
- \_\_\_ Repair or disassemble

Exchange only with the IBM-approved part. Recycle or discard the battery as instructed by local regulations. In the United States, IBM has a process for the collection of this battery. For information, call 1-800-426-4333. Have the IBM part number for the battery unit available when you call. (C003)

## **Power and cabling information for NEBS (Network Equipment-Building System) GR-1089-CORE**

The following comments apply to the IBM servers that have been designated as conforming to NEBS (Network Equipment-Building System) GR-1089-CORE:

The equipment is suitable for installation in the following:

- Network telecommunications facilities
- Locations where the NEC (National Electrical Code) applies

The intrabuilding ports of this equipment are suitable for connection to intrabuilding or unexposed wiring or cabling only. The intrabuilding ports of this equipment *must not* be metallically connected to the interfaces that connect to the OSP (outside plant) or its wiring. These interfaces are designed for use as intrabuilding interfaces only (Type 2 or Type 4 ports as described in GR-1089-CORE) and require isolation from the exposed OSP cabling. The addition of primary protectors is not sufficient protection to connect these interfaces metallically to OSP wiring.

**Note:** All Ethernet cables must be shielded and grounded at both ends.

The ac-powered system does not require the use of an external surge protection device (SPD).

The dc-powered system employs an isolated DC return (DC-I) design. The DC battery return terminal *shall not* be connected to the chassis or frame ground.

---

# Installing the IBM Power 710 Express and the IBM Power 730 Express (8231-E2B)

Follow the steps outlined in this topic collection for installing your IBM Power® 710 Express and IBM Power 730 Express (8231-E2B).

You might need to read the following documents before you begin to install the server:

- The latest version of this document is maintained online, see Overview (<http://publib.boulder.ibm.com/infocenter/systems/scope/hw/topic/p7ed9/p7ed9roadmap.htm>).
- To plan your server installation, see Planning for the system ([http://publib.boulder.ibm.com/infocenter/systems/scope/hw/topic/p7had/p7hadplankickoff\\_71x\\_73x.htm](http://publib.boulder.ibm.com/infocenter/systems/scope/hw/topic/p7had/p7hadplankickoff_71x_73x.htm)).
- If you are using a Hardware Management Console (HMC), see Obtaining and applying machine code updates for the HMC with an Internet connection (<http://publib.boulder.ibm.com/infocenter/systems/scope/hw/topic/p7hai/area3fixeshmc.htm>).

---

## Prerequisites for installing the 8231-E2B

Use the information in this topic to understand the prerequisites required for installing the system.

Ensure that you have the following items before starting your installation:

- Philips screwdriver
- Flat-head screwdriver
- Rack with two units of space: If you do not have a rack installed, see Installing the rack (<http://publib.boulder.ibm.com/infocenter/systems/scope/hw/topic/p7hbf/installrack.htm>).

You also need one of the following consoles:

- Hardware Management Console (HMC): Ensure that your HMC is at Version 7 Release 7.7.0, or later.
- Graphic monitor with keyboard and mouse.
- Teletype (TTY) monitor with keyboard.

---

## Before you begin

Understand the requirements for installing the server into a rack.

Before you begin the installation process, complete the following steps:

1. Verify that you have received all the boxes that you ordered.
2. Unpack the server components as needed.
3. Complete a parts inventory before installing each server component by following these steps:
  - a. Locate the inventory list for your server.
  - b. Ensure that you have received all the parts that you ordered.

**Note:** Your order information is located is included with your product. You can also obtain order information from your marketing representative or the IBM Business Partner.

If you have incorrect, missing, or damaged parts, consult any of the following resources:

- Your IBM reseller.
- IBM Rochester manufacturing automated information line at 1-800-300-8751 (United States only).
- Directory of worldwide contacts (<http://www.ibm.com/planetwide>). Select your location to view the service and support contact information.

---

## Installation overview

Learn how to install the server into a rack by using the slide rail and cable-management arm options.

To install the server into a rack, complete the following tasks:

1. "Installing the server into a rack" on page 3
2. "Cabling the server and setting up the console" on page 15
3. "Completing the server setup" on page 21

---

## Installing the server into a rack

With the rack installed, you must install your server into the rack and set up the cable-management arm.

**Note:** If present, use the rack-mount template to perform these tasks.

---

## Determining the location

You might need to determine where to install the system in the rack. Use this procedure to perform this task.

Before installing the system unit into a rack, complete the following steps:

1. Read the Rack safety notices (<http://publib.boulder.ibm.com/infocenter/systems/scope/hw/topic/p7hbf/racksafety.htm>).

2. Plan where to place the units. Place the larger and heavier units in the lower part of the rack.

This system unit is two Electronic Industries Alliance (EIA) units high. An EIA unit is 44.45 mm (1.75 in.) in height. The rack contains three mounting holes for each EIA unit of height. This system unit therefore is 88.9 mm (3.5 in.) high and covers 6 mounting holes in the rack.

3. If necessary, remove the filler panels to allow access to the inside of the rack enclosure where you plan to place the unit, as shown in Figure 1 on page 4.

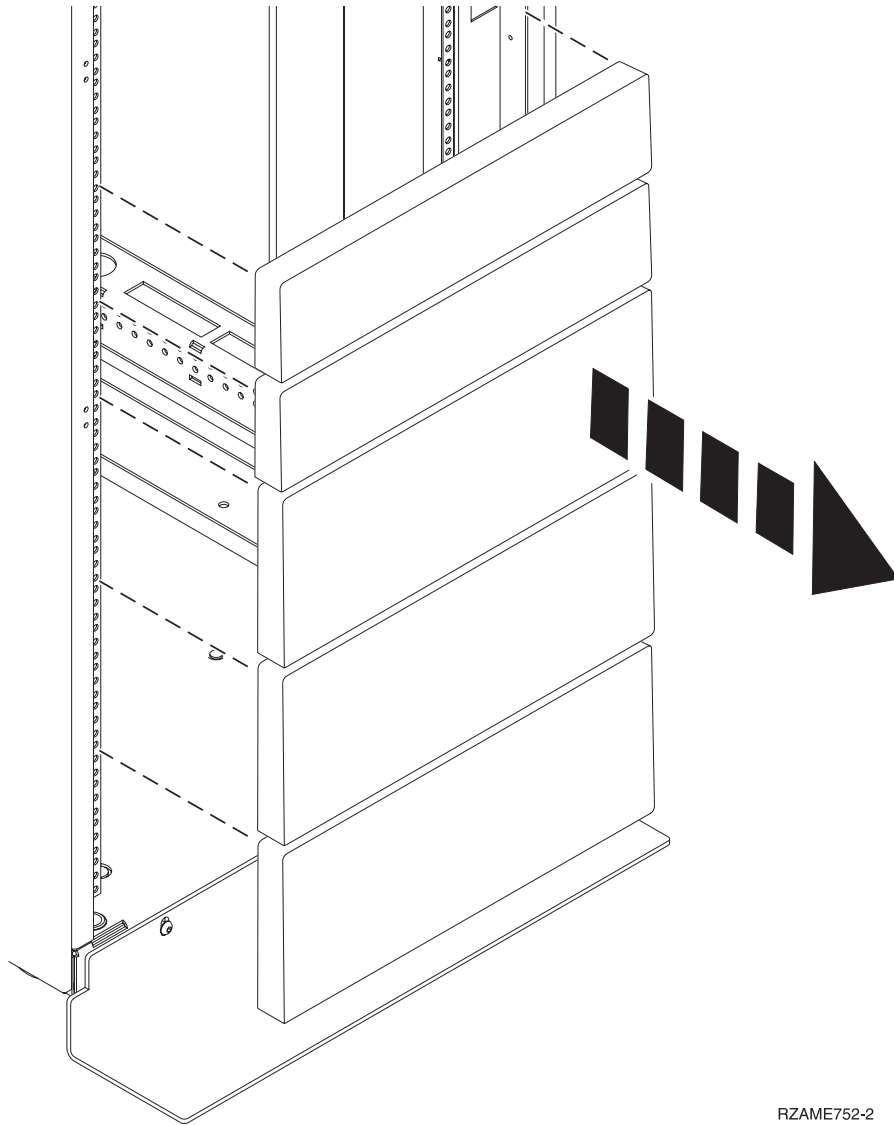

RZAME752-2

Figure 1. Removing the filler panels

4. If necessary, remove the front and rear rack doors.

## Marking the location

Learn how to mark the position on the rack for installing the slide rail.

To mark the installation location, complete the following steps:

1. Facing the front of the rack and working from the right side, locate the bottom EIA unit that your system will use. Make a note of the EIA location. Use tape, a marker, or a pencil to mark the bottom hole of this EIA unit as **A**. Mark the rack so that the mark can also be seen from the rear of the rack.

**Note:** Use the marked holes to determine where to locate the slide rails, and attach them by using the pins.



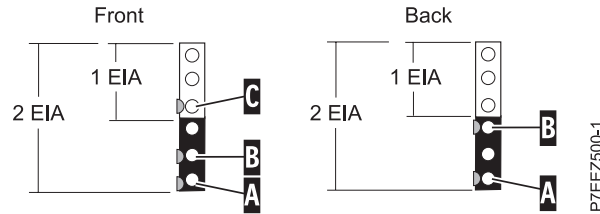

Figure 2. Marking holes on the front and rear of the rack frame

2. Beginning with the hole identified by mark **A**, count up one hole and place a second mark as **B**. Mark the rack so the mark can also be seen from the rear of the rack, as shown in Figure 2.
3. Beginning with the hole identified by mark **B**, count up two holes and place a third mark as **C**, as shown in Figure 2.
4. Facing the front of the rack and working from the left side, locate the bottom EIA unit that your expansion unit uses. Mark the bottom hole of this EIA unit as **A**.
5. Repeat steps 2 - 3 on the left side of the rack.
6. Facing the rear of the rack and working from the right side, locate the bottom EIA unit that noted in step 1 on page 4. Make a mark next to the bottom hole of this EIA unit as **A**. Mark the rack so the mark can also be seen from the front of the rack.
7. Beginning with the hole identified by mark **A**, count up two holes and place a second mark **B**, as shown in Figure 2.
8. Facing the rear of the rack and working from the left side, locate the bottom EIA unit that your expansion unit uses. Mark the bottom hole of this EIA unit as **A**.
9. Repeat step 7 on the left side of the rack.

---

## Attaching the 8231-E2B mounting hardware to the rack

You might need to attach the mounting hardware to the rack. Use the procedure in this section to perform this task. The information provided is intended to promote safety and reliable operation. This section also includes illustrations of the related hardware components and shows how these components relate to each other.

**Attention:** To avoid rail failure and potential danger to yourself and to the unit, ensure that you have the correct rails and fittings for your rack. If your rack has square support flange holes or screw-thread support flange holes, ensure that the rails and fittings match the support flange holes used on your rack. Do not install mismatched hardware using washers or spacers. If you do not have the correct rails and fittings for your rack, contact your IBM reseller.

To install the rack-mounting hardware into the rack, complete the following steps:

1. Each slide rail is marked with either an R (right) or an L (left). Select the left slide rail, bring it to the rear of the rack, and locate the selected U that was previously marked.
2. Push up on the front locking tab (1), and pull out the front latch (2) at the front of the rail. Then remove the screw from the rear of the rail (3), as shown in Figure 3 on page 6.

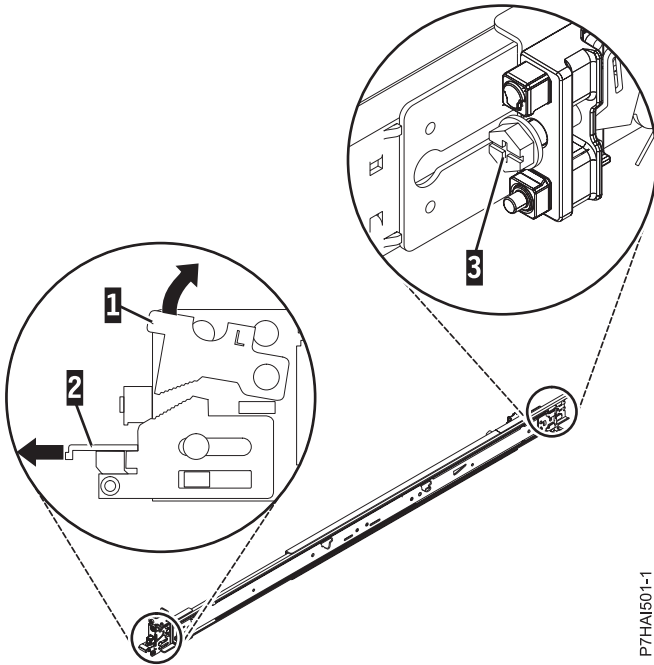

Figure 3. Opening the front latch and removing the rear screw

- Align the two pins on the rear of the slide rail with the top and bottom holes within the selected U that were previously marked. Pull the slide rail toward you to insert the two pins into the rack holes (1), and lower the slide rail down (2) to engage the hook feature on the top pin, as shown in Figure 4. Ensure the two pins protrude through the rack holes before proceeding to the next step.

**Note:** The pin fixtures of the slide rails support either round-hole or square-hole rack models.

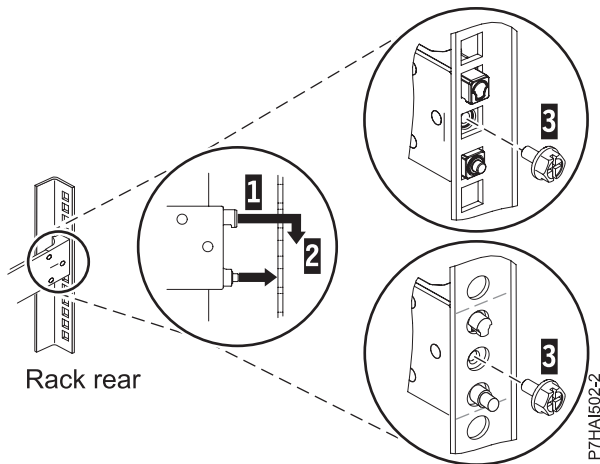

Figure 4. Aligning and engaging the pins into the holes in the rear of the rack

- Reinstall the screw that was removed in step 2 on page 5, as shown in Figure 5 on page 7.

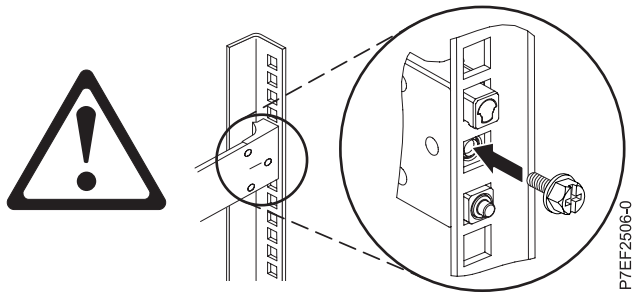

Figure 5. Reinstalling the screw

**Attention:** You must install the screw to secure the device.

5. Return to the front of the rack. Ensure the latch is still open on the front of the slide rail. Refer, step 1 on page 5.
6. Pull the slide rail forward and insert three pins on the front of the rail into the holes within the selected U that were previously marked. Lower the slide rail down **(1)** to engage the hook feature on the middle pin, as shown in Figure 6.

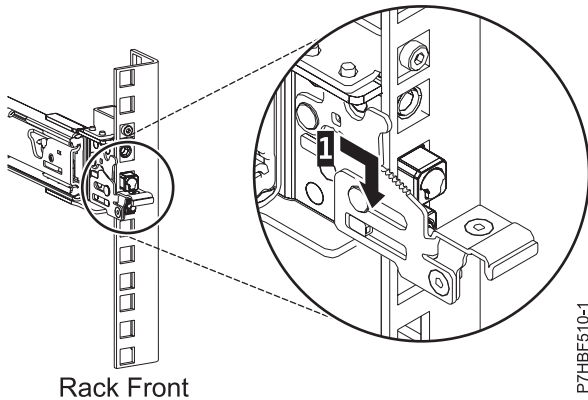

Figure 6. Front rail of the rack with pins seated

7. While pulling the slide rail forward, ensure that all three pins protrude through the rack holes, then push the front latch **(2)** all the way in, as shown in Figure 7.

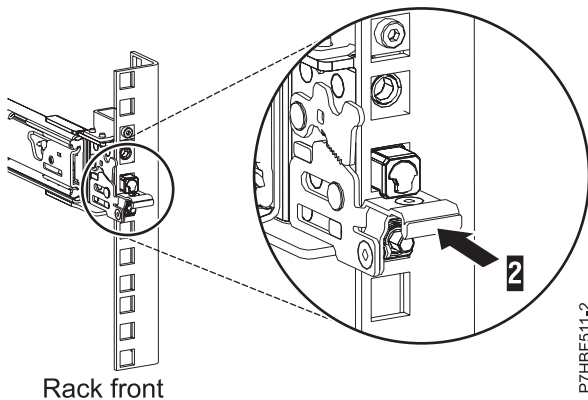

Figure 7. Front rail of the rack with latch seated

**Note:** If you need to reposition the rail, release the front latch **(2)**, and while pressing the blue pin at the bottom, push the rail toward the rear to release from the rack.

- Repeat step 1 on page 5 - 7 on page 7 to install the right rail into the rack.
- Continue with "Installing the 8231-E2B system into the rack."

---

## Installing the 8231-E2B system into the rack

Use the procedure in this topic to install the system into the rack.

### CAUTION:

**This system requires two persons to install the system into the rack.**

To install the system into the rack, complete the following steps:

- Remove the shipping cover on the rear and the front of the system, if present.
- Extend the slide rails forward (1) until they click twice into place. Carefully lift the server and tilt it into position over the slide rails so that the rear nail heads (2) on the server line up with the rear slots (3) on the slide rails. Slide the server down until the rear nail heads slip into the two rear slots, and then slowly lower the front of the server (4) until the other nail heads slip into the other slots on the slide rails. Make sure that the front latch (5) slides over the nail heads.

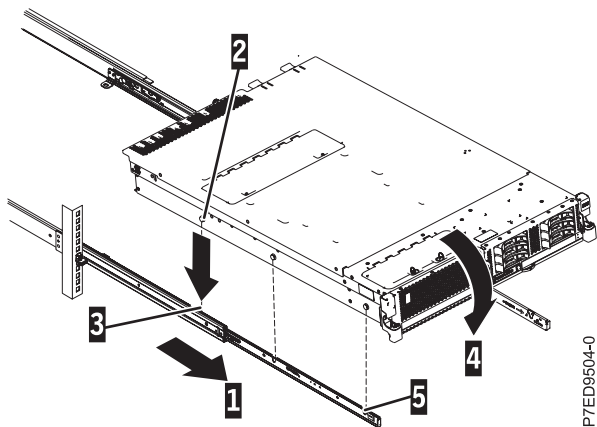

Figure 8. Extending slide rails and aligning server nail heads with the slots on the rail

- Lift the blue release latches (1) on the slide rails and push the server (2) all the way into the rack until it clicks into place.

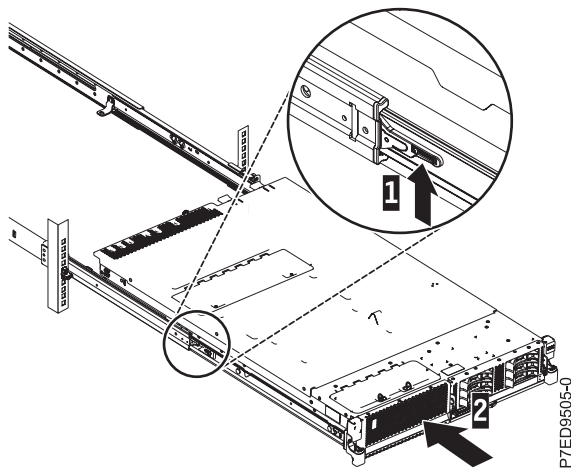

Figure 9. Release latches and server

4. Remove the shipping bracket that is on the left side of the rear of the system before you cable it. To remove the shipping bracket, complete the following steps:
  - a. Remove the two screws (A).

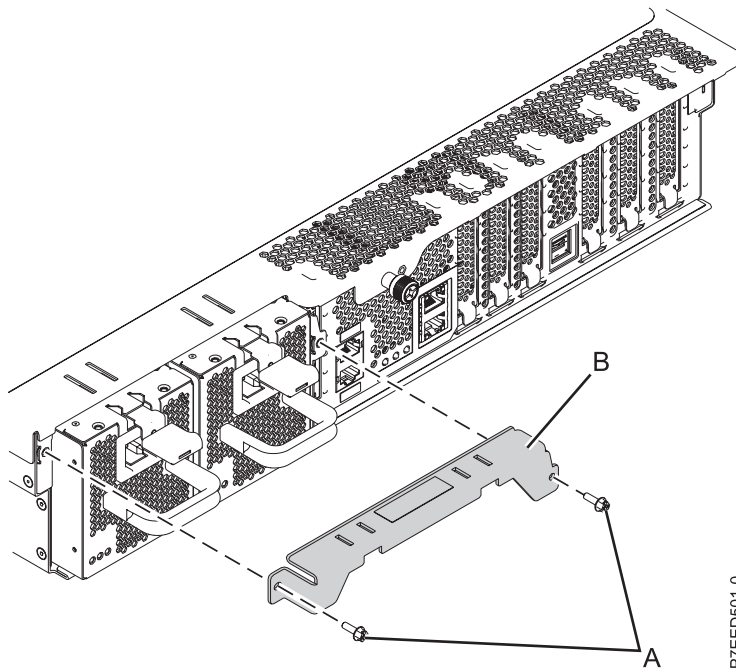

Figure 10. Removing the shipping bracket

- b. Pull the bracket off of the system (B) and discard.
  - c. Push the power supplies back into the system, ensuring that they are fully seated and latched.
5. Continue with "Installing the cable-management arm."

## Installing the cable-management arm

You might need to install the cable-management arm. Use this procedure to perform this task.

To install the cable-management arm, complete the following steps:

**Note:** The procedure for installing the cable-management arm involves the assembly of the following parts:

- A** Support arm
- B** Cable-management stop bracket
- C** Mounting bracket
- D** Cable-management arm
- E** Extension bracket

The following figure shows the parts of the cable-management arm in relative position to each other before their assembly.

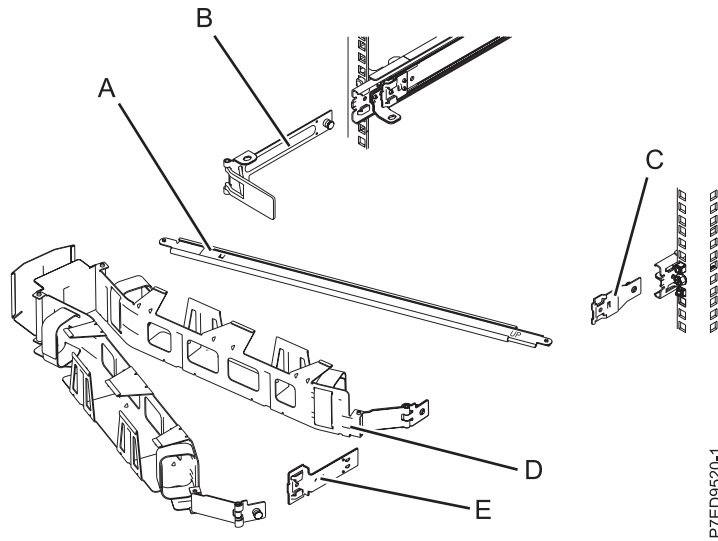

P7ED9520-1

Figure 11. Relative positions of the parts of the cable-management arm before assembly

1. The cable-management arm must be installed on the right side of the server, when you are facing it from the rear. The following figure shows it being installed on the right side. Connect one end of the support arm (A) to the right slide rail (1) so that you can swing the other end of the support arm (2) toward the left side of the rack, as shown in Figure 12.

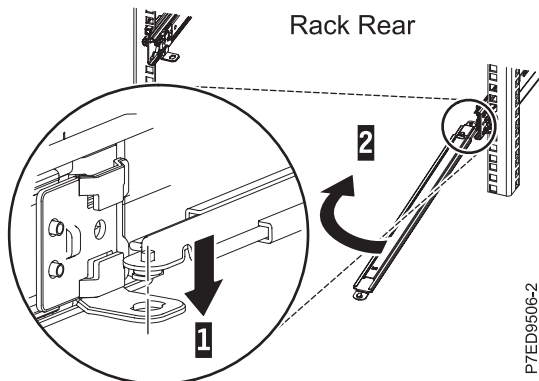

P7ED9506-2

Figure 12. Connecting the support arm

2. Locate the hole at the bottom inside corner of the L-shaped cable-management stop bracket (B). Position the unattached end of the support arm so that the locking tab on the underside of its tip aligns with the bracket hole. Insert the tab into the hole (1) and turn the bracket (2) to secure it to the support arm, as shown in Figure 13 on page 11.

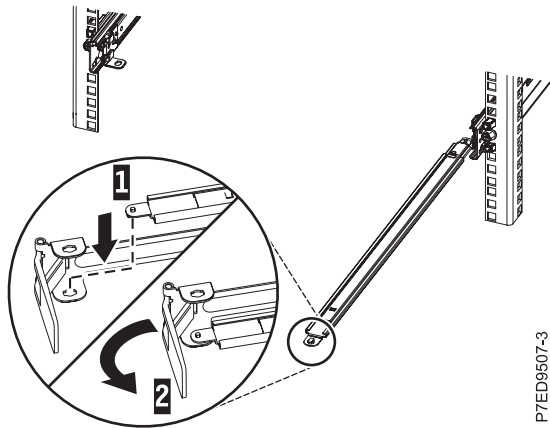

Figure 13. Securing the cable-management stop bracket to the support arm

3. To attach the other side of the support arm to the backside of the slide rail, pull the pin out (1), and then slide the bracket (B) into the left slide rail (2), as shown in Figure 14.

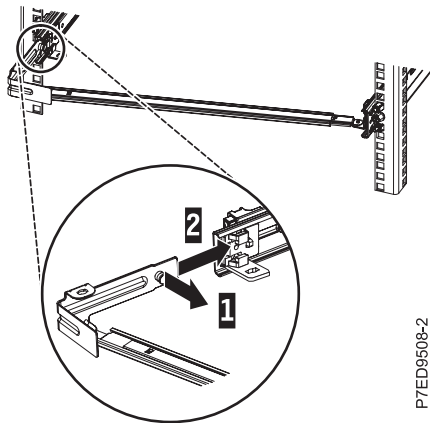

Figure 14. Extending slide rails and aligning server rail heads with the slots on the rail

4. Slide the extension bracket (E) into the right slide rail (1). Push the bracket into the slide rail until the spring-loaded latch snaps into place, as shown in Figure 15 on page 12.

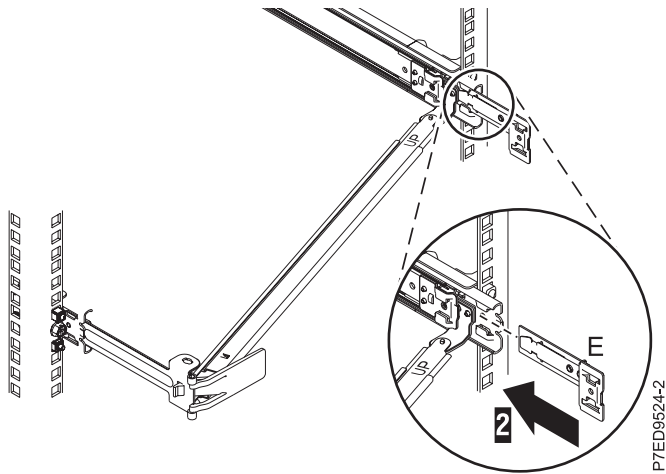

Figure 15. Installing the extension bracket into the slide rail

5. Attach the mounting bracket (C) to the slot on the inside of the right slide by pulling the pin out (1), and sliding the mounting bracket (C) into the slide rail until the spring-loaded pin snaps into place (2), as shown in Figure 16.

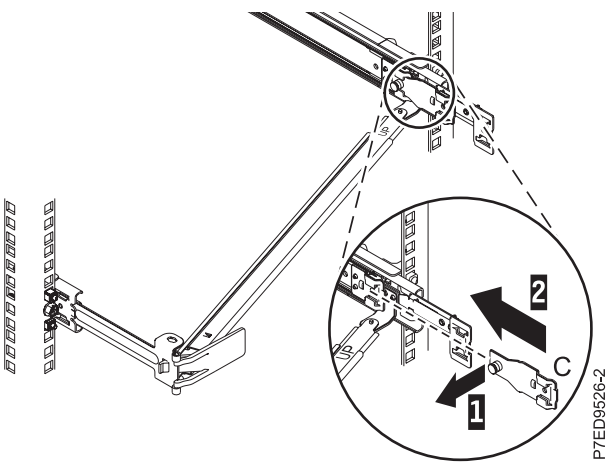

Figure 16. Installing the mounting bracket into the mounting bracket into the slide rail

6. Place the cable-management arm (D) on the support arm (A). Pull out the cable-management arm pin (1), and then slide the cable-management arm tab (2) into the slot on the mounting bracket (C). Push the tab until it snaps into place. Pull out the other cable-management arm pin (3), and then slide that cable management arm tab into the extension bracket (E) slot (4) on the outside of the right slide rail. Push the tab until it snaps into place, as shown in Figure 17 on page 13.



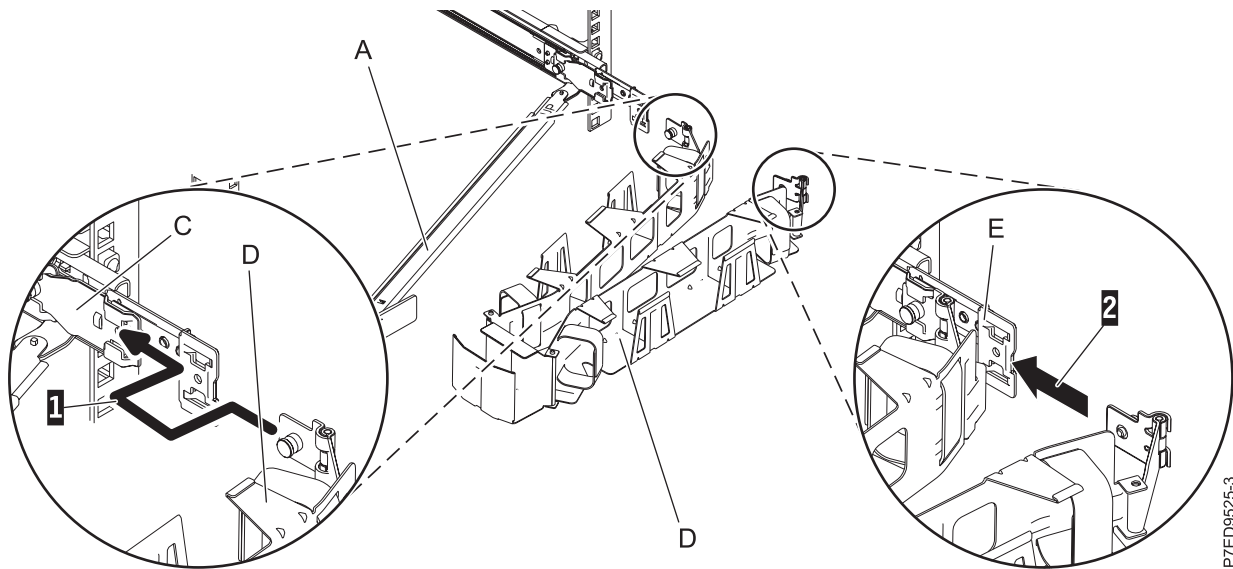

Figure 17. Connecting the cable-management arm

7. Choose an available console, interface, or terminal for installation, and cable the server. For more information, see “Cabling the server and setting up the console” on page 15.
8. Route the power cords and other cables (including keyboard, monitor, and mouse cables, if required) on the cable-management arm (1), as shown in Figure 18. Attach all cables to the rear of the server except for the power cord. Secure the cord and cables with cable ties or hook-and-loop fasteners.

**Note:** Allow slack in all cables to avoid tension in the cables as the cable-management arm moves.

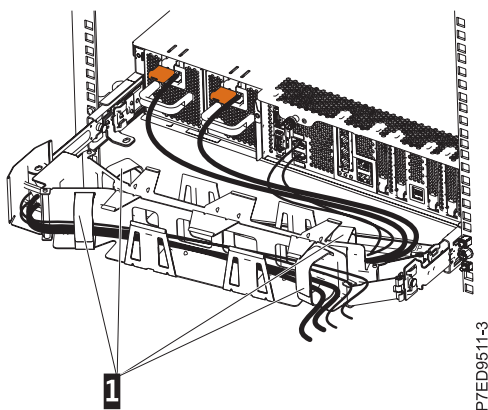

Figure 18. Attaching and routing the power cord

9. Slide the server into the rack until it snaps into place.

## Connecting the expansion units, disk drives, and PCI adapters

Use this information to learn about connecting and configuring expansion units and disk drives to system units.

1. For information on connecting expansion units, see Enclosures and expansion units (<http://publib.boulder.ibm.com/infocenter/systems/scope/hw/topic/p7ham/expansionunit.htm>).
2. For information on connecting the disk drive unit, see Disk drives (<http://publib.boulder.ibm.com/infocenter/systems/scope/hw/topic/p7hal/p7halkickoff.htm>).

3. For information on connecting PCI adapters, PCI adapter placement (<http://publib.boulder.ibm.com/infocenter/systems/scope/hw/topic/p7hak/p8231pcianddiv.htm>).

---

## Cabling the server and setting up the console

Your console, monitor, or interface choices are guided by whether you create logical partitions, which operating system you install in your primary partition, and whether you install a Virtual I/O Server in one of your logical partitions.

**Note:** If you ordered your system or expansion unit preinstalled into a rack, you must remove the shipping bracket that is on the left side of the rear of the system or expansion unit before you cable it.

Go to the instructions for the applicable console, interface, or terminal in the following table.

*Table 1. Available console types*

Console type	Operating system	Logical partitions	Cable required	Cabling and setup instructions
ASCII terminal	AIX®, Linux, or VIOS	Yes for VIOS, no for AIX and Linux	Serial cable equipped with a null modem	“Cabling the server with an ASCII terminal”
Hardware Management Console	AIX, IBM i, Linux, or VIOS	Yes	Ethernet (or cross-over cable)	“Cabling the server to the Hardware Management Console” on page 16
Integrated Virtualization Manager for VIOS	AIX, IBM i, or Linux	Yes	Ethernet cable for network connection	“Cabling the server and accessing the Integrated Virtualization Manager” on page 17
Keyboard, video, and mouse (KVM)	Linux or VIOS	Yes	Monitor and USB cables equipped with KVM	“Cabling the server with keyboard, video, and mouse” on page 18

---

### Cabling the server with an ASCII terminal

If you are not creating logical partitions, you can use an ASCII terminal to manage a server that is running the AIX, Linux, or VIOS operating systems. From the ASCII terminal, you can access the Advanced System Management Interface (ASMI) to perform additional installation tasks.

The ASCII terminal is connected to the server through a serial link. The ASCII interface to the ASMI provides a subset of the Web interface functions. The ASCII terminal is available only when the system is in the standby state. It is not available during the initial program load (IPL) or run time.

**Note:** If you are using a serial connection to the ASMI terminal, you must use a conversion cable. This cable (part number 46K5108) is used to convert the ASCII terminal 9-pin Dshell connector to an RJ45 serial port connector on the system. For more information about the locations of the connectors on the system, see 8231-E2B Locations ([http://publib.boulder.ibm.com/infocenter/systems/scope/hw/topic/p7ecs/p7ecslcodes\\_71x\\_73x.htm](http://publib.boulder.ibm.com/infocenter/systems/scope/hw/topic/p7ecs/p7ecslcodes_71x_73x.htm)).

To cable an ASCII terminal to the server, complete the following steps:

1. By using a serial cable that is equipped with a null modem, connect the ASCII terminal to system connector 1 (P1-T1, which is the default) or 2 (P1-T2) on the rear of the server.
2. Connect the power cord from the server to a power source.

3. Wait for the green light on the control panel to start flashing.
4. Ensure that your ASCII terminal is set to the following general attributes.  
These attributes are the default settings for the diagnostic programs. Be sure that your terminal is set according to these attributes before proceeding to the next step.

Table 2. Default settings for the diagnostic programs

General setup attributes	3151 /11/31/41 settings	3151 /51/61 settings	3161 /64 settings	Description
Line speed	19,200	19,200	19,200	Uses the 19,200 (bits per second) line speed to communicate with the system unit.
Word length (bits)	8	8	8	Selects 8 bits as a data word length (byte).
Parity	No	No	No	Does not add a parity bit and is used together with the word length attribute to form the 8-bit data word (byte).
Stop bit	1	1	1	Places a bit after a data word (byte).

5. Press a key on the ASCII terminal to allow the service processor to confirm the presence of the ASCII terminal.
6. When the login display appears for the ASMI, enter admin for the user ID and password.
7. Change the default password when you are prompted.  
You have completed the setup for an ASCII terminal, and have started the ASMI.
8. Continue with “Completing the server setup without using a management console” on page 23.

---

## Cabling the server to the Hardware Management Console

The Hardware Management Console (HMC) controls managed systems, including the management of logical partitions and the use of capacity on demand. Using service applications, the HMC communicates with managed systems to detect, consolidate, and forward information to IBM service for analysis.

If you have not already done so, install and configure your HMC. For instructions about installing and configuring the HMC, see Installation and configuration scenarios (<http://publib.boulder.ibm.com/infocenter/systems/scope/hw/topic/p7hai/basichmcinstallationandconfigurationtaskflow.htm>).

To manage POWER7<sup>®</sup> processor-based servers, the HMC must be at Version 7 Release 7.7.0, or later. To view the HMC version and release, complete the following steps:

1. In the navigation area, click **Updates**.
2. In the work area, view and record the information that appears in the HMC Code Level section, including the HMC version, release, maintenance level, build level, and base versions.

To cable the server to the HMC, complete the following steps:

1. If you want to directly attach your HMC to the managed system, connect **Ethernet Connector 1** on the HMC to the **LINK HMC1** port on the managed system.

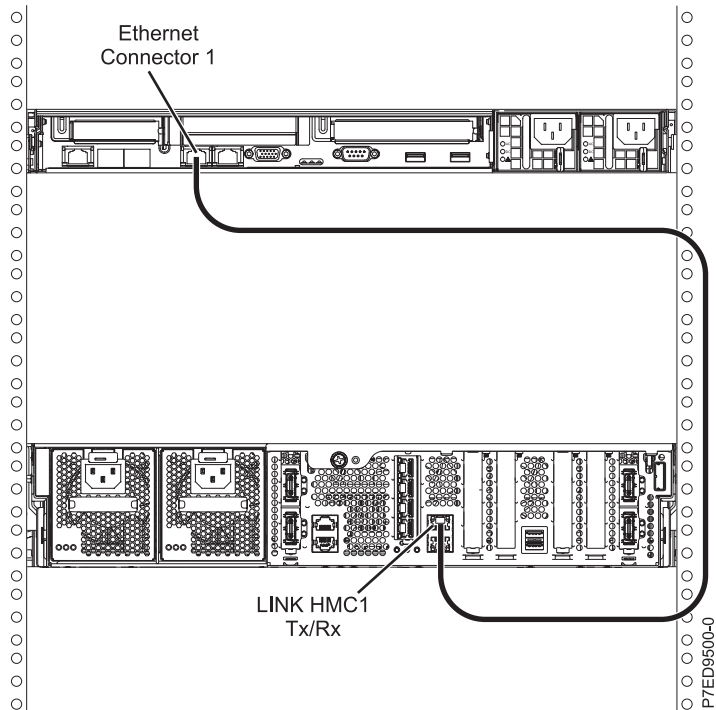

Figure 19. Attaching the HMC to the managed system

2. To learn more about connecting an HMC to a private network so that it can manage more than one managed system, see HMC network connections (<http://publib.boulder.ibm.com/infocenter/systems/scope/hw/topic/p7hai/netconhmc.htm>)

**Notes:**

- You can also have multiple systems attached to a switch that is then connected to the HMC. For more information, see HMC network connections.
  - If you are using a switch, ensure that the speed in the switch is set to **auto/auto**. If the server is directly attached to the HMC, ensure the HMC's Ethernet adapter speed is set to **auto/auto**. For more information about setting media speeds, see Setting the media speed.
3. If you are connecting a second HMC to your managed server, connect to the Ethernet port that is labeled **LINK HMC2** on the managed server.
  4. Complete your server setup. For instructions, see “Completing the server setup by using Hardware Management Console” on page 21.

---

## Cabling the server and accessing the Integrated Virtualization Manager

When you install the Virtual I/O Server in an environment where no Hardware Management Console (HMC) is present, the Virtual I/O Server automatically creates a management partition whose interface is the Integrated Virtualization Manager.

To prepare for and install the Virtual I/O Server and enable the IVM, complete the following steps:

1. Connect a serial cable from a PC or ASCII terminal to a system port on the server.
2. Do the following steps:
  - Verify that you have access to the Advanced System Management Interface (ASMI) by using the web interface. For details, see “Accessing the ASMI using a web browser” on page 28.
  - Verify that you have administrator or authorized service provider authority in ASMI.

- Using the Web-based ASMI, change the following settings as appropriate for the type of partition on which you are installing the Integrated Virtualization Manager:  
For an AIX or Linux partition, complete the following steps to change the partition boot mode:
    - a. In the navigation area, expand **Power/Restart Control**.
    - b. Click **Power On/Off System**.
    - c. Select **Boot to SMS menu** in the **AIX or Linux partition mode** by boot field.
    - d. If you are installing the Integrated Virtualization Manager on an IBM System i® model, select **AIX or Linux** in the **Default partition environment** field.
    - e. Click **Save settings and power on**.
  - Open a terminal session on the PC, using an application such as HyperTerminal, and wait for the SMS menu to appear. Be sure that the line speed is set to 19,200 bits per second to communicate with the system unit.
  - Using the Web-based ASMI, change the partition boot mode back so that the server loads the operating environment during startup:
    - a. Expand **Power/Restart Control**.
    - b. Click **Power On/Off System**.
    - c. Select **Continue to operating system** in the **AIX or Linux partition mode** boot field.
    - d. Click **Save settings**.
3. Insert the *Virtual I/O Server* CD or DVD into the optical drive.
  4. In SMS, select the CD or DVD as the boot device:
    - a. Select **Select Boot Options**, and press Enter.
    - b. Select **Select Install/Boot Device**, and press Enter.
    - c. Select **CD/DVD**, and press Enter.
    - d. Select the media type that corresponds to the optical device, and press Enter.
    - e. Select the device number that corresponds to the optical device, and press Enter.
    - f. Select **Normal Boot**, and confirm that you want to exit SMS.
  5. Install the Virtual I/O Server:
    - a. Select the console, and press Enter.
    - b. Select a language for the BOS menus, and press Enter.
    - c. Select **Start Install Now with Default Settings**.
    - d. Select **Continue with Install**. The managed system restarts after the installation is complete, and the login prompt is displayed on the ASCII terminal.
  6. After you install the IVM, finish the installation by accepting the license agreement, checking for updates, and configuring the TCP/IP connection.

Next, you need to install an operating system and enable service and support functions for your server. For instructions, see “Completing the server setup” on page 21.

---

## Cabling the server with keyboard, video, and mouse

Before booting the system, you might need to connect the keyboard, video, and mouse (KVM) to the system, if a graphics card is present.

To connect the KVM, complete the following steps:

1. Locate the graphics card and USB ports at the rear of the system. You may need a connector converter.
2. Connect the monitor cable to the graphics card.
3. Connect a keyboard and mouse to the USB ports.

4. Power on the console.
5. Connect the power cables for the server and wait for the green light on the operator panel to start flashing. For more information, see “Connecting the power cables to the system.”
6. Install an operating system and update the operating system, if required.

---

## Connecting the power cables to the system

You might need to connect power cables to the system. Use this procedure to perform this task.

**Note:** Cable the system and set up a console, interface, or terminal. To cable the system, see “Cabling the server and setting up the console” on page 15.

To connect power cables to the system, complete the following steps:

1. Remove the power-supply shipping bracket (if present), as shown in Figure 20. Ensure that the power supplies have been reseated.

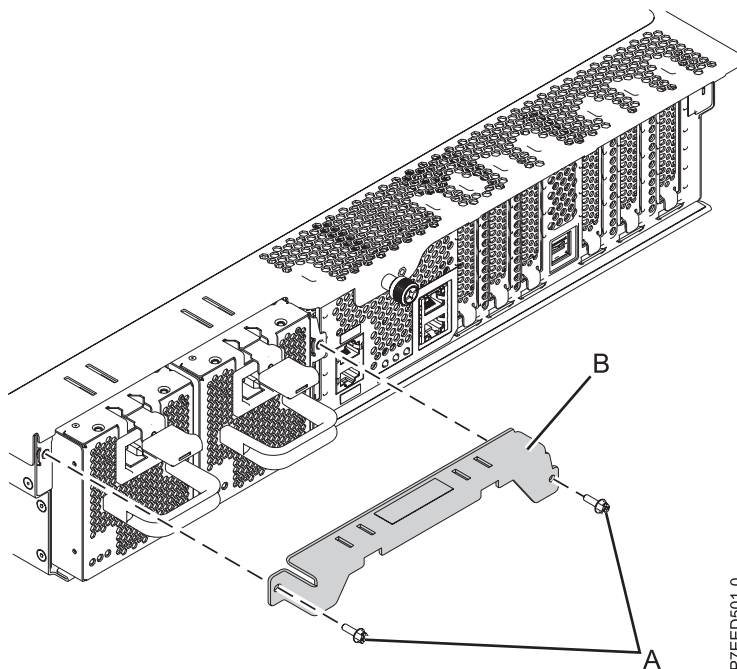
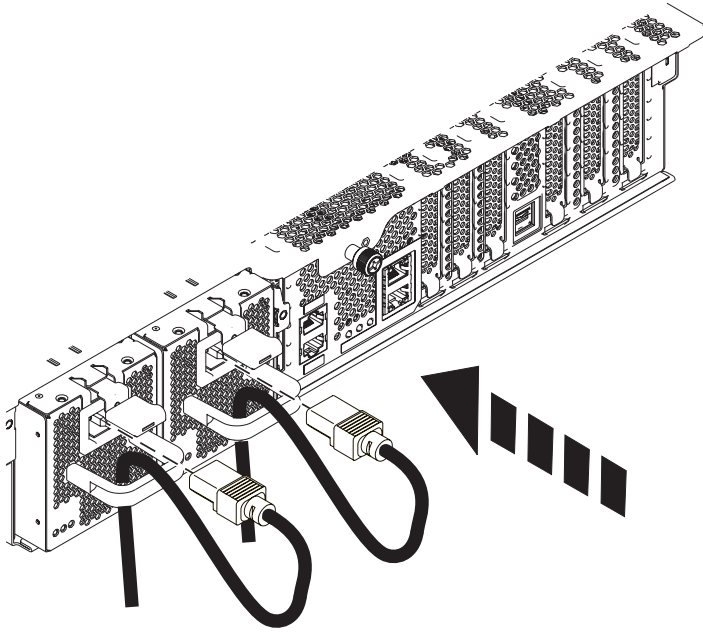

Figure 20. Removing the shipping bracket

2. While facing the rear of the system unit, route the system power cord through the cable retention bracket, as shown in Figure 21 on page 20.

**Note:** You might need to pull the power supply out slightly to route the cable through the retention bracket. After you route the cable through the retention bracket, reseal the power supply.



P7EEB502-0

Figure 21. Routing and attaching the power cord

3. Plug the power cord into the power supply.

**Note:** This system is equipped with two power supplies. If you want to configure the system with redundant power supplies, you must connect each power cable to its own power source.

4. Plug the system power cords and the power cords for any other attached devices into the alternating current (ac) power source.

**Note:** Confirm that the system is in standby mode. The green power status indicator on the front control panel is flashing slowly, and the dc out indicator lights on the power supplies are flashing. If neither indicator is flashing, check the power cord connections. For detailed information, see “Common system attention LEDs and system reference codes” on page 31.

5. If your system uses a power distribution unit (PDU), complete the following steps:
  - a. Connect the system power cords from the server and I/O drawers to the PDU with an IEC 320 type receptacle.
  - b. Attach the PDU input power cord and plug it into the alternating current (ac) power source.



---

## Completing the server setup

Learn more about the tasks that you must perform to complete your managed system installation.

If you have an Hardware Management Console (HMC), perform the following tasks:

1. Update the time of day on the managed system by using the Advanced System Management Interface (ASMI).
2. Check the firmware level on the managed system.
3. If required, update the managed system firmware levels.
4. Confirm that the system is in standby mode. The green power status indicator on the front control panel is flashing slowly, and the dc out indicator lights on the power supplies are flashing. If none of the indicators are flashing, check the power cord connections.
5. Power on the managed system.
6. Create partitions or deploy an imported system plan.
7. Install an operating system, if it is not already installed.

For instructions, see “Completing the server setup by using Hardware Management Console.”

If you do not have an HMC, perform the following tasks:

1. Check the firmware level on the managed system and update the time of day by using the ASMI.
2. Confirm that the system is in standby mode. The green power status indicator on the front control panel is flashing slowly, and the dc out indicator lights on the power supplies are flashing. If none of the indicators are flashing, check the power cord connections.
3. Power on the managed system.
4. Install and update an operating system, if it is not already installed.
5. Update the system firmware, if required.

For instructions, see “Completing the server setup without using a management console” on page 23.

---

## Completing the server setup by using Hardware Management Console

You must perform these tasks to complete the server setup by using a Hardware Management Console (HMC).

To manage POWER7 systems, the HMC must be at Version 7 Release 7.7.0, or later.

To complete the server setup by using an HMC, complete the following steps:

1. Plug in the power cords. For more information, see “Connecting the power cables to the system” on page 19.
2. Confirm that the system is in standby mode. The green power status indicator on the front control panel is flashing slowly, and the dc out indicator lights on the power supplies are flashing. If none of the indicators are flashing, check the power cord connections. For more information, see “Common system attention LEDs and system reference codes” on page 31.
3. Change the managed system passwords by completing the following steps:
  - a. In the navigation area, expand **Systems Management > Servers**.
  - b. In the content area, select the managed system.
  - c. In the operations area, select **Update passwords**.

4. Update the time of day on the managed system using the Advanced System Management Interface (ASMI).

To set up and access the ASMI, complete the following steps:

- a. In the navigation area, expand **Systems Management > Servers**.
- b. In the content area, select the managed system.
- c. In the task area, expand **Operations**.
- d. Select **Launch Advanced System Management (ASM)**.

To change the time of day by using the ASMI, complete the following steps:

- a. On the ASMI Welcome pane, specify your admin user ID and password, and click **Log In**.
  - b. In the navigation area, expand **System Configuration**.
  - c. Select **Time of Day**. The right pane displays a form that shows the current date (month, day, and year) and time (hours, minutes, and seconds).
  - d. Change the date value, the time value, or both, and click **Save settings**.
5. Check the firmware level on the managed system.

To check the firmware level on the managed system, in the navigation area, select **Updates**. Firmware information is displayed in the contents area.

6. Compare your installed firmware level with available firmware levels. If required, update your firmware levels:
  - a. Compare your installed firmware level with available firmware levels. For more information, see Fix Central website at Fix Central (<http://www.ibm.com/support/fixcentral/>).
  - b. If required, update your managed system firmware levels. In the navigation area, select **Updates**.
  - c. In the content area, select your managed system.
  - d. Select **Change Licensed Internal Code for the current release**.

7. Power on your managed system by using the correct Power-On Parameter. To power on your managed system by using the HMC, complete the following steps:

- a. View your managed system's properties and verify that the logical partition start policy is set to **User-Initiated**. To verify that the logical partition start policy is set to **User-Initiated**, do the following:
  - 1) In the navigation area, expand **Systems Management > Servers**.
  - 2) In the content area, select the managed system.
  - 3) In the tasks area, click **Properties**.
  - 4) Click the **Power-On Parameters** tab.
  - 5) Ensure that the **Partition start policy** field is set to **User-Initiated**.
- b. Power on the managed system. To power on the managed system, do the following:
  - 1) In the navigation area, expand **Systems Management > Servers**.
  - 2) In the content area, select the managed system.
  - 3) Select **Operations > Power On**.
  - 4) Select a power on option and click **OK**.

8. Create partitions or deploy an imported system plan.

For instructions about creating partitions, see Partitioning with the HMC (<http://publib.boulder.ibm.com/infocenter/systems/scope/hw/topic/p7hat/iphblparwithhmc6.htm>).

For instructions about deploying system plans, see Deploying a system plan by using an HMC (<http://publib.boulder.ibm.com/infocenter/systems/scope/hw/topic/p7hc6/iphc6deploysysplan6.htm>).

9. Install an operating system and update the operating system.

For instructions to install the VIOS operating system, see Installing VIOS (<http://publib.boulder.ibm.com/infocenter/systems/scope/hw/topic/p7hch/iphchinstallvios.htm>).

---

## Completing the server setup without using a management console

You must perform these tasks to complete the server setup if you do not have a Hardware Management Console (HMC).

1. Plug in the power cords. For more information, see “Connecting the power cables to the system” on page 19.
2. Confirm that the system is in standby mode. The green power status indicator on the front control panel is flashing slowly, and the dc out indicator lights on the power supplies are flashing. If none of the indicators are flashing, check the power cord connections. For more information, see “Common system attention LEDs and system reference codes” on page 31.
3. To check the firmware level on the managed system and to update the time of day, complete the following steps:
  - a. Access the Advanced System Management Interface (ASMI). For more information, see Accessing the ASMI without an HMC ([http://publib.boulder.ibm.com/infocenter/systems/scope/hw/topic/p7hby/connect\\_asmi.htm](http://publib.boulder.ibm.com/infocenter/systems/scope/hw/topic/p7hby/connect_asmi.htm)).
  - b. On the ASMI Welcome pane, note the existing level of server firmware in the upper-right corner under the copyright statement.
  - c. Update the time of day. In the navigation area, expand **System Configuration**.
  - d. Select **Time of Day**. The right pane displays a form that shows the current date (month, day, and year) and time (hours, minutes, and seconds).
  - e. Change the date value, the time value, or both, and click **Save settings**.
4. Connect your disk drives, and PCI adapters, if applicable. For more information, see Disk drives (<http://publib.boulder.ibm.com/infocenter/systems/scope/hw/topic/p7hal/p7halkickoff.htm>), and PCI adapters ([http://publib.boulder.ibm.com/infocenter/systems/scope/hw/topic/p7hak/p7hak\\_pciadapters\\_front.htm](http://publib.boulder.ibm.com/infocenter/systems/scope/hw/topic/p7hak/p7hak_pciadapters_front.htm)).
5. See Power on (<http://publib.boulder.ibm.com/infocenter/systems/scope/hw/topic/p7hby/poweronoff.htm>).
6. To start a system that is not managed by an HMC or ASMI, complete the following steps:
  - a. Open the front door of the managed system.
  - b. Press the power button on the control panel.
7. Install an operating system and update the operating system, if required.

For instructions to install the VIOS operating system, see Installing VIOS (<http://publib.boulder.ibm.com/infocenter/systems/scope/hw/topic/p7hch/iphchinstallvios.htm>).
8. Update the system firmware, if required.
  - For instructions to get firmware fixes through the AIX or Linux operating system, see Getting server firmware fixes through AIX or Linux without a management console ([http://publib.boulder.ibm.com/infocenter/systems/scope/hw/topic/p7ha5/fix\\_firm\\_no\\_hmc\\_aix.htm](http://publib.boulder.ibm.com/infocenter/systems/scope/hw/topic/p7ha5/fix_firm_no_hmc_aix.htm)).
  - If you are using VIOS, see Updating the Virtual I/O Server's firmware and device microcode with an Internet connection ([http://publib.boulder.ibm.com/infocenter/systems/scope/hw/topic/p7ha5/fix\\_virtual\\_firm\\_ivm.htm](http://publib.boulder.ibm.com/infocenter/systems/scope/hw/topic/p7ha5/fix_virtual_firm_ivm.htm)).



---

## Reference information

Use this information to learn more about the tasks associated with a system installation.

---

### Installing rack-mounted and factory-racked servers

Use this information to learn about installing rack-mounted and factory-racked servers.

**Note:** The screws included in the shipment are used to secure the drawer to the rack. Use these screws if you are moving the rack and drawer to another location, or if you are in an area prone to vibrations or earthquakes.

### Installing the rack-mounted server

You might need to install a rack-mounted server. Use this procedure to perform this task.

To install the rack-mounted server, complete the following high-level tasks:

*Table 3. Tasks to install the server into a rack*

Task	Where to find associated information
Check the prerequisites.	For more information, see "Prerequisites for installing the 8231-E2B" on page 1.
Perform the inventory.	For more information, see "Before you begin" on page 1.
Verify that you have a rack.	You must first have a rack installed. If you do not have a rack installed, see Installing the rack ( <a href="http://publib.boulder.ibm.com/infocenter/systems/scope/hw/topic/p7hbf/installrack.htm">http://publib.boulder.ibm.com/infocenter/systems/scope/hw/topic/p7hbf/installrack.htm</a> ).
Determine where you want to install the rails and mark the location.	To determine and mark the location, see "Determining the location" on page 3 and "Marking the location" on page 4.
Attach the mounting hardware to the rack.	To install the mounting hardware to the rack, see "Attaching the 8231-E2B mounting hardware to the rack" on page 5.
Install the system into the rack.	To install the system into the rack, see "Installing the 8231-E2B system into the rack" on page 8.
Install the cable management arm.	To install the cable management arm, see "Installing the cable-management arm" on page 9.

Table 3. Tasks to install the server into a rack (continued)

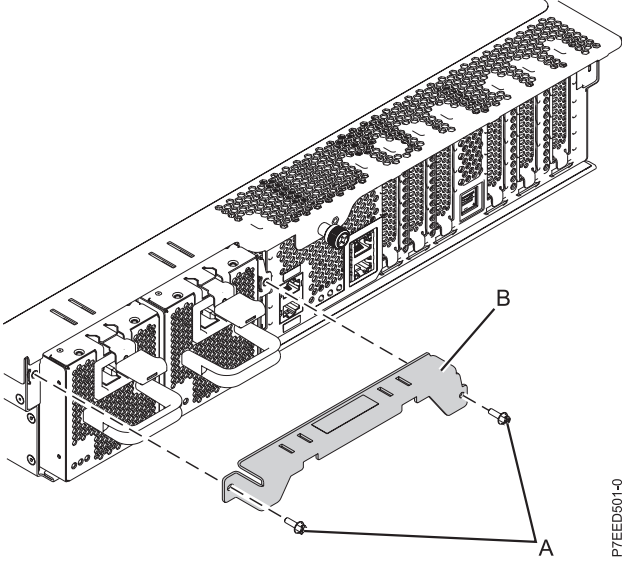
Task	Where to find associated information
<p>Remove the shipping bracket on the rear of the system that protects the power supplies. This is not needed for installation.</p> <p><b>Note:</b> Depending on your configuration, there might be orange shipping brackets on either side of the rear of the system and also covering the power supplies. Both the shipping bracket must be removed.</p>	<p>To remove the shipping bracket, do the following:</p> <ol style="list-style-type: none"> <li>1. Remove the screws.</li> <li>2. Pull the power supplies out slightly so that you can remove the shipping bracket.</li> <li>3. Reseat the power supplies.</li> <li>4. If expansion units are present, remove the shipping brackets that cover the power supplies.</li> </ol>  <p style="text-align: right; font-size: small;">P7EED001-0</p>
<p>Connect your expansion unit, disk drives, and PCI adapters, if applicable.</p> <p><b>Notes:</b></p> <ul style="list-style-type: none"> <li>• Consult your project manager or read the system plans before moving or installing any disk drives and PCI adapters.</li> <li>• Do not power on your system. You will be instructed to power on the system when you set up the console.</li> </ul>	<p>For more information, see Enclosures and expansion units (<a href="http://publib.boulder.ibm.com/infocenter/systems/scope/hw/topic/p7ham/expansionunit.htm">http://publib.boulder.ibm.com/infocenter/systems/scope/hw/topic/p7ham/expansionunit.htm</a>), Disk drives (<a href="http://publib.boulder.ibm.com/infocenter/systems/scope/hw/topic/p7hal/p7halkickoff_71x_73x.htm">http://publib.boulder.ibm.com/infocenter/systems/scope/hw/topic/p7hal/p7halkickoff_71x_73x.htm</a>), and <a href="http://publib.boulder.ibm.com/infocenter/systems/scope/hw/topic/p7hak/p8231pcianddiv.htm">http://publib.boulder.ibm.com/infocenter/systems/scope/hw/topic/p7hak/p8231pcianddiv.htm</a> (<a href="http://publib.boulder.ibm.com/infocenter/systems/scope/hw/topic/p7hak/p8231pcianddiv.htm">http://publib.boulder.ibm.com/infocenter/systems/scope/hw/topic/p7hak/p8231pcianddiv.htm</a>).</p>
<p>Cable the mouse, keyboard, and monitor, if required.</p>	<p>For more information, see “Cabling the server with keyboard, video, and mouse” on page 18.</p>
<p>Cable the system and set up a console, interface, or terminal.</p>	<p>For more information, see “Cabling the server and setting up the console” on page 15.</p>
<p>Connect the power cables to the system and apply power.</p>	<p>For more information, see “Connecting the power cables to the system” on page 19.</p>
<p>Complete the server setup.</p>	<p>For more information, see “Completing the server setup” on page 21.</p>

## Installing the factory-racked server

You might need to install the factory-racked server. Use this procedure to perform this task.

To install a server that is already in a factory-installed rack, complete the following high-level tasks:

Table 4. Tasks to install the factory-racked server

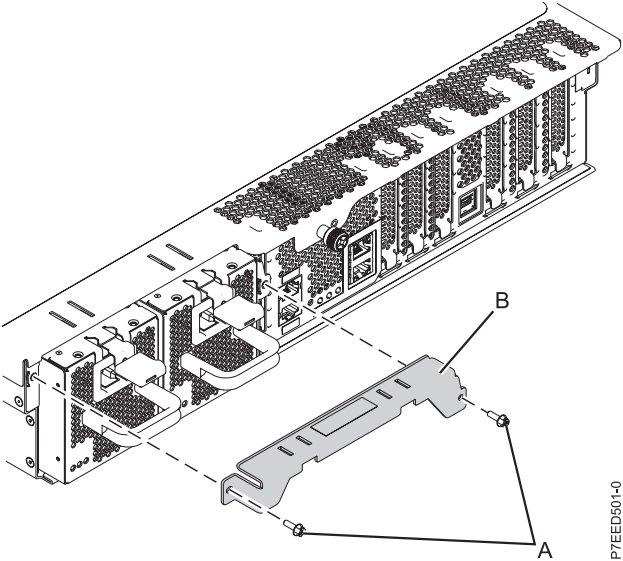
Task	Where to find associated information
Check the prerequisites.	For more information, see “Prerequisites for installing the 8231-E2B” on page 1.
Perform the inventory.	For more information, see “Before you begin” on page 1.
<p>Remove the shipping bracket on the rear of the system that protects the power supplies. This is not needed for installation.</p> <p><b>Note:</b> Depending on your configuration, there might be orange shipping brackets on either side of the rear of the system and also covering the power supplies. Both the shipping bracket must be removed.</p>	<p>To remove the shipping bracket, do the following:</p> <ol style="list-style-type: none"> <li>1. Remove the screws.</li> <li>2. Pull the power supplies out slightly so that you can remove the shipping bracket.</li> <li>3. Reseat the power supplies.</li> <li>4. If expansion units are present, remove the shipping brackets that cover the power supplies.</li> </ol>  <p style="text-align: right; font-size: small;">P7EED501-0</p>
<p>Connect your expansion unit, disk drives, and PCI adapters, if applicable.</p> <p><b>Notes:</b></p> <ul style="list-style-type: none"> <li>• Consult your project manager or read the system plans before moving or installing any disk drives and PCI adapters.</li> <li>• Do not power on your system. You will be instructed to power on the system when you set up the console.</li> </ul>	<p>For more information, see Enclosures and expansion units (<a href="http://publib.boulder.ibm.com/infocenter/systems/scope/hw/topic/p7ham/expansionunit.htm">http://publib.boulder.ibm.com/infocenter/systems/scope/hw/topic/p7ham/expansionunit.htm</a>), Disk drives (<a href="http://publib.boulder.ibm.com/infocenter/systems/scope/hw/topic/p7hal/p7halkickoff_71x_73x.htm">http://publib.boulder.ibm.com/infocenter/systems/scope/hw/topic/p7hal/p7halkickoff_71x_73x.htm</a>), and <a href="http://publib.boulder.ibm.com/infocenter/systems/scope/hw/topic/p7hak/p8231pcianddiv.htm">http://publib.boulder.ibm.com/infocenter/systems/scope/hw/topic/p7hak/p8231pcianddiv.htm</a> (<a href="http://publib.boulder.ibm.com/infocenter/systems/scope/hw/topic/p7hak/p8231pcianddiv.htm">http://publib.boulder.ibm.com/infocenter/systems/scope/hw/topic/p7hak/p8231pcianddiv.htm</a>).</p>
Cable the mouse, keyboard, and monitor, if required.	For more information, see “Cabling the server with keyboard, video, and mouse” on page 18.
Cable the system and set up a console, interface, or terminal.	For more information, see “Cabling the server and setting up the console” on page 15.
Connect the power cables to the system and apply power.	For more information, see “Connecting the power cables to the system” on page 19.
Complete the server setup.	For more information, see “Completing the server setup” on page 21.



---

## Supporting information for setting up consoles

Use this information if you need to access the Advanced System Management Interface using a web browser, need to set IP addresses on your notebook, or need to troubleshoot a connection.

### Accessing the ASMI using a web browser

If your system is not managed by an HMC, you can connect a PC or notebook to the server to access the Advanced System Management Interface (ASMI). You need to configure the Web browser address on the PC or notebook to match the manufacturing default address on the server.

To set up the Web browser for direct or remote access to the ASMI, complete the following steps:

1. If the server is not powered on, perform the following steps:
  - a. Connect your power cord or cords to the server.
  - b. Plug the power cord or cords into the power source.
  - c. Wait for the control panel to display 01. A series of progress codes are shown before 01 appears.

**Notes:**

- The system is powered on if the light on the control panel is green.
- To view the control panel, press the blue switch to the left, then pull out the control panel all the way, and then pull it down.

**Important:** Do not connect an Ethernet cable to either the HMC1 port or the HMC2 port until you are directed to do so later in this procedure.

2. Select a PC or notebook that has Netscape 9.0.0.4, Microsoft Internet Explorer 7.0, Opera 9.24, or Mozilla Firefox 2.0.0.11 to connect to your server.

**Note:** If the PC or notebook on which you are viewing this document does not have two Ethernet connections, another PC or notebook needs to be connected to your server to access the ASMI.

If you do not plan to connect your server to your network, this PC or notebook is your ASMI console.

If you plan to connect your server to your network, this PC or notebook temporarily connects directly to the server for setup purposes only. After setup, you can use any PC or notebook on your network that is running Netscape 9.0.0.4, Microsoft Internet Explorer 7.0, Opera 9.24, or Mozilla Firefox 2.0.0.11 as your ASMI console.

**Note:** Complete the following steps to disable the TLS 1.0 option in Microsoft Internet Explorer to access the ASMI using Microsoft Internet Explorer 7.0 running on Windows XP:

- a. From the **Tools** menu in Microsoft Internet Explorer, select **Internet Options**.
  - b. From the Internet Options window, click the **Advanced** tab.
  - c. Clear the **Use TLS 1.0** check box (in the Security category) and click **OK**.
3. Connect an Ethernet cable from the PC or notebook to the Ethernet port labeled HMC1 on the back of the managed system. If HMC1 is occupied, connect an Ethernet cable from the PC or notebook to the Ethernet port labeled HMC2 on the back of the managed system.

**Important:** If you attach an Ethernet cable to the service processor before the system reaches power off standby, the IP address shown in Table 5 on page 29 might not be valid. For details, see “Correcting an IP address” on page 30.

4. Determine the current IP address. If the network link is not active, then zero configuration networking automatically creates a usable IP network address without manual operator intervention or special configuration servers.
5. Use Table 5 on page 29 to help you determine and record the information needed to set the IP address of the service processor on the PC or notebook. The Ethernet interface on the PC or



notebook needs to be configured within the same subnet mask as the service processor so that they can communicate with each other. For example, if you connected your PC or notebook to HMC1, the IP address for your PC or notebook could be 169.254.2.140 and the subnet mask would be 255.255.255.0. Set the gateway IP address to the same IP address as the PC or notebook

Table 5. Network configuration information for the service processor in a POWER7 processor-based system

POWER7 processor-based systems	Server connector	Subnet mask	IP address of the service processor	Example of an IP address for your PC or notebook
Service processor A	HMC1	255.255.255.0	169.254.2.147	169.254.2.140
	HMC2	255.255.255.0	169.254.3.147	169.254.3.140
Service processor B (if installed)	HMC1	255.255.255.0	169.254.2.146	169.254.2.140
	HMC2	255.255.255.0	169.254.3.146	169.254.3.140

6. Set the IP address on your PC or notebook by using the values from the table. For details, see “Setting the IP address on your PC or notebook.”
7. To access the ASMI using a Web browser, perform the following steps:
  - a. Use Table 5 to determine the IP address of the service processor Ethernet port that your PC or notebook is connected to.
  - b. Type the IP address in the **Address** field on the Web browser of your PC or notebook and press Enter. For example, if you connected your PC or notebook to HMC1, type `https://169.254.2.147` in the Web browser on your PC or notebook.

**Note:** It might take up to 2 minutes for the ASMI login display to be shown in the Web browser after the Ethernet cable is plugged into the service processor in step 3 on page 28. During this time, if you use control panel function 30 to view the IP addresses on the service processor, incomplete or inaccurate data is shown.

8. When the Login display appears, enter admin for the user ID and password.
9. Change the default password when prompted.
10. Choose from the following options:
  - If you do not plan to connect your PC or notebook to your network, this ends this procedure. You can now perform tasks such as changing the time of day or changing the altitude setting.
  - If you plan to connect your PC or notebook to your network, see Accessing the ASMI without an HMC ([http://publib.boulder.ibm.com/infocenter/systems/scope/hw/topic/p7hby/connect\\_asmi.htm](http://publib.boulder.ibm.com/infocenter/systems/scope/hw/topic/p7hby/connect_asmi.htm)).

## Setting the IP address on your PC or notebook

To access the ASMI through a Web browser, you first need to set the IP address on a PC or notebook. The following procedures describe setting the IP address on a PC or notebook running the Microsoft Windows XP, 2000, and Vista operating systems.

You will need the information you recorded in step 5 on page 28 in “Accessing the ASMI using a web browser” on page 28 to complete the following procedure.

### Windows XP and Windows 2000

To set the IP address within Windows XP and Windows 2000, do the following steps:

1. Click **Start > Control Panel**.
2. On the control panel, double-click **Network Connections**.
3. Right-click **Local Area Connection**.
4. Click **Properties**.
5. Select **Internet Protocol (TCP/IP)**, and then click **Properties**.

**Attention:** Record the current settings before making any changes. Use this information to restore these settings if you disconnect the PC or notebook after setting up the ASMI Web interface.

**Note:** If Internet Protocol (TCP/IP) does not appear in the list, do the following steps:

- a. Click **Install**.
  - b. Select **Protocol**, and then click **Add**.
  - c. Select **Internet Protocol (TCP/IP)**.
  - d. Click **OK** to return to the Local Area Connection Properties window.
6. Select **Use the Following IP Address**.
  7. Complete the **IP address**, **Subnet mask**, and **Default gateway** fields by using the values you recorded in “Accessing the ASMI using a web browser” on page 28 task.
  8. Click **OK** on the Local Area Connection Properties window. It is not necessary to restart your PC.

## Windows Vista

To set the IP address within Windows Vista, do the following steps:

1. Click **Start > Control Panel**.
2. Ensure **Classic View** is selected.
3. Select **Network and Sharing Center**.
4. Select **View status** in the Public network area.
5. Click **Properties**.
6. If the Security window is shown, click **Continue**.
7. Highlight **Internet Protocol Version 4** and click **Properties**.
8. Select **Use the following IP address**.
9. Complete the **IP address**, **Subnet mask**, and **Default gateway** fields by using the values you recorded in “Accessing the ASMI using a web browser” on page 28 procedure.
10. Click **OK > Close > Close**.

## Correcting an IP address

If you attach an Ethernet cable to the service processor before the system reaches power off standby, the IP address shown in the service processor network configuration table might not be valid.

If a cable is attached and not connected to anything, nothing happens. The address could potentially change if an Ethernet cable that is attached to a network is connected to that port and the system is turned on. If you are unable to access the ASMI using a network connection, you must perform one of the following tasks:

- Attach an ASCII terminal to the service processor using a serial cable. For details, see “Cabling the server with an ASCII terminal” on page 15.
- Determine the current IP address. For more information about determining the current service processor IP address, see Function 30: Service processor IP address and port location.
- Move the reset toggle switches on the service processor from their current position to the opposite position. To perform this task, you must remove and replace the service processor. For details, contact your next level of support.

## Common system attention LEDs and system reference codes

Learn more about how to recover from common installation problems.

The following table describes LED status behaviors and describes the meaning of each behavior.

*Table 6. Common installation system attention LEDs*

Front power status LED (green)	ac in (green)	dc out (green)	Fault (yellow)	Description
On	On	On	Off	Power is being supplied to the system and the system is powered on.
Flashing	On	Flashing	Off	Power is being supplied to the system.
Flashing	Off	Flashing	Off	Power is not being supplied to one of the power supplies, but power is being supplied to the second power supply, and the system is in standby mode.
On	Off	Flashing	Off	Power is not being supplied to one of the power supplies, but power is being supplied to the second power supply, and the system is powered on.
Off	Off	Off	Off	Power is not being supplied to either power supply.
Flashing	On	Off or flashing	On	Power is being applied, but the power supply is not functioning properly and the system is in standby mode.
On	On	Off or flashing	On	Power is being applied, but the power supply is not functioning properly and the system is powered on.
Flashing	On	On	On	110 volts are being applied. This system requires 220 volts.

The following table describes system reference codes (SRCs) that you might encounter during installation.

*Table 7. Common installation SRCs*

SRC	Error description	Recovery steps
1000xxx 1100xxx 509Axxx 509Dxxx 50A4xxx 50ADxxx 50B1xxx	ac input and power supply connections	<ol style="list-style-type: none"> <li>Verify that line cords are plugged in correctly in the following locations: <ul style="list-style-type: none"> <li>Drawer</li> <li>Power distribution unit (PDU), if applicable</li> <li>Battery backup unit (BBU), if applicable</li> <li>Input source power receptacle</li> </ul> </li> <li>Verify that the power supplies are seated and latched into position.</li> </ol>
11002613	Your power voltages do not match	Ensure that you are using the correct power voltage. Refer to your server's specifications to learn more about the power voltage that your server requires.

Table 7. Common installation SRCs (continued)

SRC	Error description	Recovery steps
Starts with 27xxx, 28xx, 57xxx  and ends with xxxx3120, xxxx3121	Fibre Channel port failure	These errors are often caused by ports that are not used. Every port must have a cable or wrap plug installed. Whenever a cable is not installed, ensure that a wrap plug is installed for each unused port. Wrap plugs are shipped automatically when a Fibre Channel feature code is ordered.
B1A38B24	Network configuration	Ensure that you have entered the correct IP address.

## Best practices for integrating cable and system placement

These guidelines ensure that your system and its cables have optimal clearance for maintenance and other operations. The guidelines also provide guidance in correctly cabling your system and using the appropriate cables.

The following guidelines provide cabling information for installing, migrating, relocating, or upgrading your system:

- Position drawers in racks to allow enough space, where possible, for cable routing on the bottom and top of the rack, and between drawers.
- Shorter drawers should not be placed between longer drawers in the rack (for example, placing a 19-inch drawer between two 24-inch drawers).
- When a specific cable plugging sequence is required, for example, for concurrent maintenance (symmetric multiprocessing cables), label the cables appropriately and note the sequence order.
- To facilitate cable routing, install cables in the following order:
  1. System power control network (SPCN) cables
  2. Power cables
  3. Communications (serial attached SCSI, InfiniBand, remote input/output, and peripheral component interconnect express) cables

**Note:** Install and route the communications cables, starting with the smallest diameter first and then progressing to the largest diameter. This applies to installing them into the cable management arm and retaining them to the rack, brackets, and other features that may be provided for cable management.

- Install and route the communications cables, starting with smallest diameter first and then progressing to the largest diameter.
- Use the innermost cable-management bridge lances for SPCN cables.
- Use the middle cable-management bridge lances for power and communications cables.
- The outermost row of cable-management bridge lances are available for use when routing cables.
- Use the cable raceways on the sides of the rack to manage excess SPCN and power cables.
- There are four cable-management bridge lances on the top of the rack. Use these bridge lances to route the cables from one side of the rack to the other, by routing to the top of the rack, where possible. This routing helps to avoid having a cable bundle that blocks the cable exit opening at the bottom of the rack.
- Use the cable management brackets provided with the system to maintain concurrent maintenance routing.
- Maintain a minimum bend diameter of 101.6 mm (4 in.) for communications (SAS, IB, RIO, and PCIe) cables.
- Maintain a minimum bend diameter of 50.8 mm (2 in.) for power cables.
- Maintain a minimum bend diameter of 25.4 mm (1 in.) for SPCN cables.

- Use the shortest-length cable available for each point-to-point connection.
- If cables have to be routed across the rear of a drawer, leave enough slack to reduce the tension on the cables for maintenance of the drawer.
- When routing cables, leave enough slack around the power connection on the power distribution unit (PDU) so that the wall-to-PDU line cord can be attached to the PDU.
- Use hook-and-loop fasteners where necessary.

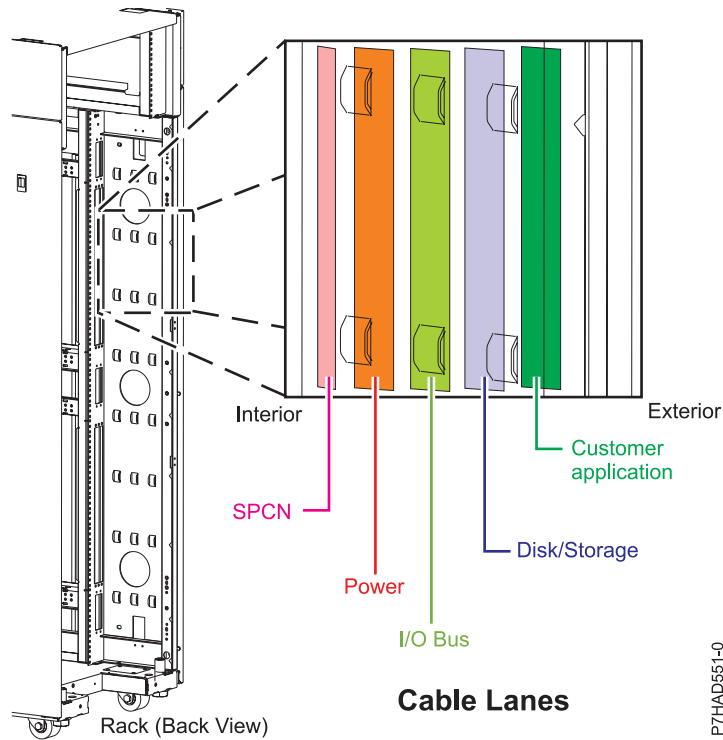

Figure 22. Cable management bridge lances

## Cable bend radius

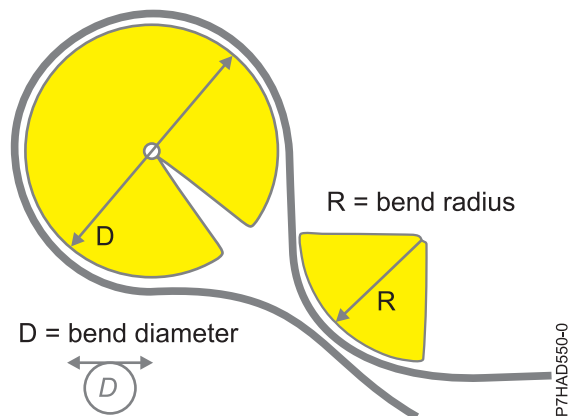

Figure 23. Cable bend radius

**Related information:**

 [POWER7 770/780 Cabling guide](#)

---

## Notices

This information was developed for products and services offered in the U.S.A.

The manufacturer may not offer the products, services, or features discussed in this document in other countries. Consult the manufacturer's representative for information on the products and services currently available in your area. Any reference to the manufacturer's product, program, or service is not intended to state or imply that only that product, program, or service may be used. Any functionally equivalent product, program, or service that does not infringe any intellectual property right of the manufacturer may be used instead. However, it is the user's responsibility to evaluate and verify the operation of any product, program, or service.

The manufacturer may have patents or pending patent applications covering subject matter described in this document. The furnishing of this document does not grant you any license to these patents. You can send license inquiries, in writing, to the manufacturer.

**The following paragraph does not apply to the United Kingdom or any other country where such provisions are inconsistent with local law:** THIS PUBLICATION IS PROVIDED "AS IS" WITHOUT WARRANTY OF ANY KIND, EITHER EXPRESS OR IMPLIED, INCLUDING, BUT NOT LIMITED TO, THE IMPLIED WARRANTIES OF NON-INFRINGEMENT, MERCHANTABILITY OR FITNESS FOR A PARTICULAR PURPOSE. Some states do not allow disclaimer of express or implied warranties in certain transactions, therefore, this statement may not apply to you.

This information could include technical inaccuracies or typographical errors. Changes are periodically made to the information herein; these changes will be incorporated in new editions of the publication. The manufacturer may make improvements and/or changes in the product(s) and/or the program(s) described in this publication at any time without notice.

Any references in this information to websites not owned by the manufacturer are provided for convenience only and do not in any manner serve as an endorsement of those websites. The materials at those websites are not part of the materials for this product and use of those websites is at your own risk.

The manufacturer may use or distribute any of the information you supply in any way it believes appropriate without incurring any obligation to you.

Any performance data contained herein was determined in a controlled environment. Therefore, the results obtained in other operating environments may vary significantly. Some measurements may have been made on development-level systems and there is no guarantee that these measurements will be the same on generally available systems. Furthermore, some measurements may have been estimated through extrapolation. Actual results may vary. Users of this document should verify the applicable data for their specific environment.

Information concerning products not produced by this manufacturer was obtained from the suppliers of those products, their published announcements or other publicly available sources. This manufacturer has not tested those products and cannot confirm the accuracy of performance, compatibility or any other claims related to products not produced by this manufacturer. Questions on the capabilities of products not produced by this manufacturer should be addressed to the suppliers of those products.

All statements regarding the manufacturer's future direction or intent are subject to change or withdrawal without notice, and represent goals and objectives only.

The manufacturer's prices shown are the manufacturer's suggested retail prices, are current and are subject to change without notice. Dealer prices may vary.

This information is for planning purposes only. The information herein is subject to change before the products described become available.

This information contains examples of data and reports used in daily business operations. To illustrate them as completely as possible, the examples include the names of individuals, companies, brands, and products. All of these names are fictitious and any similarity to the names and addresses used by an actual business enterprise is entirely coincidental.

If you are viewing this information in softcopy, the photographs and color illustrations may not appear.

The drawings and specifications contained herein shall not be reproduced in whole or in part without the written permission of the manufacturer.

The manufacturer has prepared this information for use with the specific machines indicated. The manufacturer makes no representations that it is suitable for any other purpose.

The manufacturer's computer systems contain mechanisms designed to reduce the possibility of undetected data corruption or loss. This risk, however, cannot be eliminated. Users who experience unplanned outages, system failures, power fluctuations or outages, or component failures must verify the accuracy of operations performed and data saved or transmitted by the system at or near the time of the outage or failure. In addition, users must establish procedures to ensure that there is independent data verification before relying on such data in sensitive or critical operations. Users should periodically check the manufacturer's support websites for updated information and fixes applicable to the system and related software.

## **Homologation statement**

This product may not be certified in your country for connection by any means whatsoever to interfaces of public telecommunications networks. Further certification may be required by law prior to making any such connection. Contact an IBM representative or reseller for any questions.

---

## **Trademarks**

IBM, the IBM logo, and [ibm.com](http://ibm.com) are trademarks or registered trademarks of International Business Machines Corp., registered in many jurisdictions worldwide. Other product and service names might be trademarks of IBM or other companies. A current list of IBM trademarks is available on the web at [www.ibm.com/legal/copytrade.shtml](http://www.ibm.com/legal/copytrade.shtml).

INFINIBAND, InfiniBand Trade Association, and the INFINIBAND design marks are trademarks and/or service marks of the INFINIBAND Trade Association.

Linux is a registered trademark of Linus Torvalds in the United States, other countries, or both.

Microsoft and Windows are trademarks of Microsoft Corporation in the United States, other countries, or both.

---

## **Electronic emission notices**

When attaching a monitor to the equipment, you must use the designated monitor cable and any interference suppression devices supplied with the monitor.

## **Class A Notices**

The following Class A statements apply to the IBM servers that contain the POWER7 processor and its features unless designated as electromagnetic compatibility (EMC) Class B in the feature information.



## **Federal Communications Commission (FCC) statement**

**Note:** This equipment has been tested and found to comply with the limits for a Class A digital device, pursuant to Part 15 of the FCC Rules. These limits are designed to provide reasonable protection against harmful interference when the equipment is operated in a commercial environment. This equipment generates, uses, and can radiate radio frequency energy and, if not installed and used in accordance with the instruction manual, may cause harmful interference to radio communications. Operation of this equipment in a residential area is likely to cause harmful interference, in which case the user will be required to correct the interference at his own expense.

Properly shielded and grounded cables and connectors must be used in order to meet FCC emission limits. IBM is not responsible for any radio or television interference caused by using other than recommended cables and connectors or by unauthorized changes or modifications to this equipment. Unauthorized changes or modifications could void the user's authority to operate the equipment.

This device complies with Part 15 of the FCC rules. Operation is subject to the following two conditions: (1) this device may not cause harmful interference, and (2) this device must accept any interference received, including interference that may cause undesired operation.

## **Industry Canada Compliance Statement**

This Class A digital apparatus complies with Canadian ICES-003.

## **Avis de conformité à la réglementation d'Industrie Canada**

Cet appareil numérique de la classe A est conforme à la norme NMB-003 du Canada.

## **European Community Compliance Statement**

This product is in conformity with the protection requirements of EU Council Directive 2004/108/EC on the approximation of the laws of the Member States relating to electromagnetic compatibility. IBM cannot accept responsibility for any failure to satisfy the protection requirements resulting from a non-recommended modification of the product, including the fitting of non-IBM option cards.

This product has been tested and found to comply with the limits for Class A Information Technology Equipment according to European Standard EN 55022. The limits for Class A equipment were derived for commercial and industrial environments to provide reasonable protection against interference with licensed communication equipment.

European Community contact:  
IBM Deutschland GmbH  
Technical Regulations, Department M372  
IBM-Allee 1, 71139 Ehningen, Germany  
Tele: +49 7032 15 2941  
email: lugi@de.ibm.com

**Warning:** This is a Class A product. In a domestic environment, this product may cause radio interference, in which case the user may be required to take adequate measures.

## VCCI Statement - Japan

この装置は、クラスA 情報技術装置です。この装置を家庭環境で使用すると電波妨害を引き起こすことがあります。この場合には使用者が適切な対策を講ずるよう要求されることがあります。

VCCI-A

The following is a summary of the VCCI Japanese statement in the box above:

This is a Class A product based on the standard of the VCCI Council. If this equipment is used in a domestic environment, radio interference may occur, in which case, the user may be required to take corrective actions.

### Japanese Electronics and Information Technology Industries Association (JEITA) Confirmed Harmonics Guideline (products less than or equal to 20 A per phase)

高調波ガイドライン適合品

### Japanese Electronics and Information Technology Industries Association (JEITA) Confirmed Harmonics Guideline with Modifications (products greater than 20 A per phase)

高調波ガイドライン準用品

## Electromagnetic Interference (EMI) Statement - People's Republic of China

### 声 明

此为 A 级产品, 在生活环境中, 该产品可能会造成无线电干扰。在这种情况下, 可能需要用户对其干扰采取切实可行的措施。

Declaration: This is a Class A product. In a domestic environment this product may cause radio interference in which case the user may need to perform practical action.

## Electromagnetic Interference (EMI) Statement - Taiwan

警告使用者：  
這是甲類的資訊產品，在居住的環境中使用時，可能會造成射頻干擾，在這種情況下，使用者會被要求採取某些適當的對策。

The following is a summary of the EMI Taiwan statement above.

Warning: This is a Class A product. In a domestic environment this product may cause radio interference in which case the user will be required to take adequate measures.

### IBM Taiwan Contact Information:

台灣IBM 產品服務聯絡方式：  
台灣國際商業機器股份有限公司  
台北市松仁路7號3樓  
電話：0800-016-888

## Electromagnetic Interference (EMI) Statement - Korea

이 기기는 업무용(A급)으로 전자파적합기기로서 판매자 또는 사용자는 이 점을 주의하시기 바라며, 가정외의 지역에서 사용하는 것을 목적으로 합니다.

## Germany Compliance Statement

### Deutschsprachiger EU Hinweis: Hinweis für Geräte der Klasse A EU-Richtlinie zur Elektromagnetischen Verträglichkeit

Dieses Produkt entspricht den Schutzanforderungen der EU-Richtlinie 2004/108/EG zur Angleichung der Rechtsvorschriften über die elektromagnetische Verträglichkeit in den EU-Mitgliedsstaaten und hält die Grenzwerte der EN 55022 Klasse A ein.

Um dieses sicherzustellen, sind die Geräte wie in den Handbüchern beschrieben zu installieren und zu betreiben. Des Weiteren dürfen auch nur von der IBM empfohlene Kabel angeschlossen werden. IBM übernimmt keine Verantwortung für die Einhaltung der Schutzanforderungen, wenn das Produkt ohne Zustimmung von IBM verändert bzw. wenn Erweiterungskomponenten von Fremdherstellern ohne Empfehlung von IBM gesteckt/eingebaut werden.

EN 55022 Klasse A Geräte müssen mit folgendem Warnhinweis versehen werden:  
"Warnung: Dieses ist eine Einrichtung der Klasse A. Diese Einrichtung kann im Wohnbereich Funk-Störungen verursachen; in diesem Fall kann vom Betreiber verlangt werden, angemessene Maßnahmen zu ergreifen und dafür aufzukommen."

#### **Deutschland: Einhaltung des Gesetzes über die elektromagnetische Verträglichkeit von Geräten**

Dieses Produkt entspricht dem "Gesetz über die elektromagnetische Verträglichkeit von Geräten (EMVG)". Dies ist die Umsetzung der EU-Richtlinie 2004/108/EG in der Bundesrepublik Deutschland.

#### **Zulassungsbescheinigung laut dem Deutschen Gesetz über die elektromagnetische Verträglichkeit von Geräten (EMVG) (bzw. der EMC EG Richtlinie 2004/108/EG) für Geräte der Klasse A**

Dieses Gerät ist berechtigt, in Übereinstimmung mit dem Deutschen EMVG das EG-Konformitätszeichen - CE - zu führen.

Verantwortlich für die Einhaltung der EMV Vorschriften ist der Hersteller:  
International Business Machines Corp.  
New Orchard Road  
Armonk, New York 10504  
Tel: 914-499-1900

Der verantwortliche Ansprechpartner des Herstellers in der EU ist:  
IBM Deutschland GmbH  
Technical Regulations, Abteilung M372  
IBM-Allee 1, 71139 Ehningen, Germany  
Tel: +49 7032 15 2941  
email: lugi@de.ibm.com

Generelle Informationen:

**Das Gerät erfüllt die Schutzanforderungen nach EN 55024 und EN 55022 Klasse A.**

#### **Electromagnetic Interference (EMI) Statement - Russia**

**ВНИМАНИЕ! Настоящее изделие относится к классу А.  
В жилых помещениях оно может создавать  
радиопомехи, для снижения которых необходимы  
дополнительные меры**

#### **Class B Notices**

The following Class B statements apply to features designated as electromagnetic compatibility (EMC) Class B in the feature installation information.

#### **Federal Communications Commission (FCC) statement**

This equipment has been tested and found to comply with the limits for a Class B digital device, pursuant to Part 15 of the FCC Rules. These limits are designed to provide reasonable protection against harmful interference in a residential installation.

This equipment generates, uses, and can radiate radio frequency energy and, if not installed and used in accordance with the instructions, may cause harmful interference to radio communications. However, there is no guarantee that interference will not occur in a particular installation.

If this equipment does cause harmful interference to radio or television reception, which can be determined by turning the equipment off and on, the user is encouraged to try to correct the interference by one or more of the following measures:

- Reorient or relocate the receiving antenna.
- Increase the separation between the equipment and receiver.
- Connect the equipment into an outlet on a circuit different from that to which the receiver is connected.
- Consult an IBM-authorized dealer or service representative for help.

Properly shielded and grounded cables and connectors must be used in order to meet FCC emission limits. Proper cables and connectors are available from IBM-authorized dealers. IBM is not responsible for any radio or television interference caused by unauthorized changes or modifications to this equipment. Unauthorized changes or modifications could void the user's authority to operate this equipment.

This device complies with Part 15 of the FCC rules. Operation is subject to the following two conditions: (1) this device may not cause harmful interference, and (2) this device must accept any interference received, including interference that may cause undesired operation.

### **Industry Canada Compliance Statement**

This Class B digital apparatus complies with Canadian ICES-003.

### **Avis de conformité à la réglementation d'Industrie Canada**

Cet appareil numérique de la classe B est conforme à la norme NMB-003 du Canada.

### **European Community Compliance Statement**

This product is in conformity with the protection requirements of EU Council Directive 2004/108/EC on the approximation of the laws of the Member States relating to electromagnetic compatibility. IBM cannot accept responsibility for any failure to satisfy the protection requirements resulting from a non-recommended modification of the product, including the fitting of non-IBM option cards.

This product has been tested and found to comply with the limits for Class B Information Technology Equipment according to European Standard EN 55022. The limits for Class B equipment were derived for typical residential environments to provide reasonable protection against interference with licensed communication equipment.

European Community contact:  
IBM Deutschland GmbH  
Technical Regulations, Department M372  
IBM-Allee 1, 71139 Ehningen, Germany  
Tele: +49 7032 15 2941  
email: [lugi@de.ibm.com](mailto:lugi@de.ibm.com)

## VCCI Statement - Japan

この装置は、クラスB情報技術装置です。この装置は、家庭環境で使用することを目的としていますが、この装置がラジオやテレビジョン受信機に近接して使用されると、受信障害を引き起こすことがあります。

取扱説明書に従って正しい取り扱いをして下さい。 VCCI-B

## Japanese Electronics and Information Technology Industries Association (JEITA) Confirmed Harmonics Guideline (products less than or equal to 20 A per phase)

高調波ガイドライン適合品

## Japanese Electronics and Information Technology Industries Association (JEITA) Confirmed Harmonics Guideline with Modifications (products greater than 20 A per phase)

高調波ガイドライン準用品

## IBM Taiwan Contact Information

台灣IBM 產品服務聯絡方式：  
台灣國際商業機器股份有限公司  
台北市松仁路7號3樓  
電話：0800-016-888

## Electromagnetic Interference (EMI) Statement - Korea

이 기기는 가정용(B급)으로 전자파적합기기로서 주로 가정에서 사용하는 것을 목적으로 하며, 모든 지역에서 사용할 수 있습니다.

## Germany Compliance Statement

Deutschsprachiger EU Hinweis: Hinweis für Geräte der Klasse B EU-Richtlinie zur Elektromagnetischen Verträglichkeit

Dieses Produkt entspricht den Schutzanforderungen der EU-Richtlinie 2004/108/EG zur Angleichung der Rechtsvorschriften über die elektromagnetische Verträglichkeit in den EU-Mitgliedsstaaten und hält die Grenzwerte der EN 55022 Klasse B ein.

Um dieses sicherzustellen, sind die Geräte wie in den Handbüchern beschrieben zu installieren und zu betreiben. Des Weiteren dürfen auch nur von der IBM empfohlene Kabel angeschlossen werden. IBM übernimmt keine Verantwortung für die Einhaltung der Schutzanforderungen, wenn das Produkt ohne Zustimmung von IBM verändert bzw. wenn Erweiterungskomponenten von Fremdherstellern ohne Empfehlung von IBM gesteckt/eingebaut werden.

#### **Deutschland: Einhaltung des Gesetzes über die elektromagnetische Verträglichkeit von Geräten**

Dieses Produkt entspricht dem "Gesetz über die elektromagnetische Verträglichkeit von Geräten (EMVG)". Dies ist die Umsetzung der EU-Richtlinie 2004/108/EG in der Bundesrepublik Deutschland.

#### **Zulassungsbescheinigung laut dem Deutschen Gesetz über die elektromagnetische Verträglichkeit von Geräten (EMVG) (bzw. der EMC EG Richtlinie 2004/108/EG) für Geräte der Klasse B**

Dieses Gerät ist berechtigt, in Übereinstimmung mit dem Deutschen EMVG das EG-Konformitätszeichen - CE - zu führen.

Verantwortlich für die Einhaltung der EMV Vorschriften ist der Hersteller:  
International Business Machines Corp.  
New Orchard Road  
Armonk, New York 10504  
Tel: 914-499-1900

Der verantwortliche Ansprechpartner des Herstellers in der EU ist:  
IBM Deutschland GmbH  
Technical Regulations, Abteilung M372  
IBM-Allee 1, 71139 Ehningen, Germany  
Tel: +49 7032 15 2941  
email: lugi@de.ibm.com

Generelle Informationen:

**Das Gerät erfüllt die Schutzanforderungen nach EN 55024 und EN 55022 Klasse B.**

---

## **Terms and conditions**

Permissions for the use of these publications are granted subject to the following terms and conditions.

**Applicability:** These terms and conditions are in addition to any terms of use for the IBM website.

**Personal Use:** You may reproduce these publications for your personal, noncommercial use provided that all proprietary notices are preserved. You may not distribute, display or make derivative works of these publications, or any portion thereof, without the express consent of IBM.

**Commercial Use:** You may reproduce, distribute and display these publications solely within your enterprise provided that all proprietary notices are preserved. You may not make derivative works of these publications, or reproduce, distribute or display these publications or any portion thereof outside your enterprise, without the express consent of IBM.

**Rights:** Except as expressly granted in this permission, no other permissions, licenses or rights are granted, either express or implied, to the Publications or any information, data, software or other intellectual property contained therein.

IBM reserves the right to withdraw the permissions granted herein whenever, in its discretion, the use of the publications is detrimental to its interest or, as determined by IBM, the above instructions are not being properly followed.

You may not download, export or re-export this information except in full compliance with all applicable laws and regulations, including all United States export laws and regulations.

IBM MAKES NO GUARANTEE ABOUT THE CONTENT OF THESE PUBLICATIONS. THE PUBLICATIONS ARE PROVIDED "AS-IS" AND WITHOUT WARRANTY OF ANY KIND, EITHER EXPRESSED OR IMPLIED, INCLUDING BUT NOT LIMITED TO IMPLIED WARRANTIES OF MERCHANTABILITY, NON-INFRINGEMENT, AND FITNESS FOR A PARTICULAR PURPOSE.







Part Number: 00L5065

Printed in USA

GI11-9820-04



(1P) P/N: 00L5065

