

Power Systems

*Installing the 5802 and 5877
expansion units*



Power Systems

*Installing the 5802 and 5877
expansion units*



Note

Before using this information and the product it supports, read the information in “Safety notices” on page v, “Notices” on page 41, the *IBM Systems Safety Notices* manual, G229-9054, and the *IBM Environmental Notices and User Guide*, Z125-5823.

This edition applies to IBM Power Systems™ servers that contain the POWER7 processor and to all associated models.

© Copyright IBM Corporation 2010, 2013.

US Government Users Restricted Rights – Use, duplication or disclosure restricted by GSA ADP Schedule Contract with IBM Corp.

Contents

Safety notices	v
Installing the 5802 and 5877 expansion units.	1
Installing the 5802 and 5877 expansion units: Details	3
Reference information	27
Connector locations	27
Server connectors	27
Model 8202-E4B connector locations	27
Model 8202-E4C connector locations	28
Model 8202-E4D connector locations	29
Model 8205-E6B connector locations	30
Model 8205-E6C connector locations	30
Model 8205-E6D connector locations	31
Model 8231-E1C connector locations	32
Model 8231-E2C connector locations	32
Model 8231-E2D connector locations	33
Model 8233-E8B connector locations	34
Model 8246-L1S connector locations	35
Model 8246-L2S connector locations	35
Model 8248-L4T, 8408-E8D, or 9109-RMD connector locations.	35
Model 8412-EAD connector locations	36
Model 9117-MMB or 9179-MHB connector locations	37
Model 9117-MMC or 9179-MHC connector locations.	38
Model 9117-MMD or 9179-MHD connector locations	38
Enclosure connectors	39
Model 5802 and 5877 connector locations	39
Notices	41
Trademarks	42
Electronic emission notices	42
Class A Notices	42
Class B Notices	46
Terms and conditions	49

Safety notices

Safety notices may be printed throughout this guide:

- **DANGER** notices call attention to a situation that is potentially lethal or extremely hazardous to people.
- **CAUTION** notices call attention to a situation that is potentially hazardous to people because of some existing condition.
- **Attention** notices call attention to the possibility of damage to a program, device, system, or data.

World Trade safety information

Several countries require the safety information contained in product publications to be presented in their national languages. If this requirement applies to your country, safety information documentation is included in the publications package (such as in printed documentation, on DVD, or as part of the product) shipped with the product. The documentation contains the safety information in your national language with references to the U.S. English source. Before using a U.S. English publication to install, operate, or service this product, you must first become familiar with the related safety information documentation. You should also refer to the safety information documentation any time you do not clearly understand any safety information in the U.S. English publications.

Replacement or additional copies of safety information documentation can be obtained by calling the IBM Hotline at 1-800-300-8751.

German safety information

Das Produkt ist nicht für den Einsatz an Bildschirmarbeitsplätzen im Sinne § 2 der Bildschirmarbeitsverordnung geeignet.

Laser safety information

IBM® servers can use I/O cards or features that are fiber-optic based and that utilize lasers or LEDs.

Laser compliance

IBM servers may be installed inside or outside of an IT equipment rack.

DANGER

When working on or around the system, observe the following precautions:

Electrical voltage and current from power, telephone, and communication cables are hazardous. To avoid a shock hazard:

- Connect power to this unit only with the IBM provided power cord. Do not use the IBM provided power cord for any other product.
- Do not open or service any power supply assembly.
- Do not connect or disconnect any cables or perform installation, maintenance, or reconfiguration of this product during an electrical storm.
- The product might be equipped with multiple power cords. To remove all hazardous voltages, disconnect all power cords.
- Connect all power cords to a properly wired and grounded electrical outlet. Ensure that the outlet supplies proper voltage and phase rotation according to the system rating plate.
- Connect any equipment that will be attached to this product to properly wired outlets.
- When possible, use one hand only to connect or disconnect signal cables.
- Never turn on any equipment when there is evidence of fire, water, or structural damage.
- Disconnect the attached power cords, telecommunications systems, networks, and modems before you open the device covers, unless instructed otherwise in the installation and configuration procedures.
- Connect and disconnect cables as described in the following procedures when installing, moving, or opening covers on this product or attached devices.

To Disconnect:

1. Turn off everything (unless instructed otherwise).
2. Remove the power cords from the outlets.
3. Remove the signal cables from the connectors.
4. Remove all cables from the devices.

To Connect:

1. Turn off everything (unless instructed otherwise).
2. Attach all cables to the devices.
3. Attach the signal cables to the connectors.
4. Attach the power cords to the outlets.
5. Turn on the devices.

(D005)

DANGER

Observe the following precautions when working on or around your IT rack system:

- Heavy equipment—personal injury or equipment damage might result if mishandled.
- Always lower the leveling pads on the rack cabinet.
- Always install stabilizer brackets on the rack cabinet.
- To avoid hazardous conditions due to uneven mechanical loading, always install the heaviest devices in the bottom of the rack cabinet. Always install servers and optional devices starting from the bottom of the rack cabinet.
- Rack-mounted devices are not to be used as shelves or work spaces. Do not place objects on top of rack-mounted devices.



- Each rack cabinet might have more than one power cord. Be sure to disconnect all power cords in the rack cabinet when directed to disconnect power during servicing.
- Connect all devices installed in a rack cabinet to power devices installed in the same rack cabinet. Do not plug a power cord from a device installed in one rack cabinet into a power device installed in a different rack cabinet.
- An electrical outlet that is not correctly wired could place hazardous voltage on the metal parts of the system or the devices that attach to the system. It is the responsibility of the customer to ensure that the outlet is correctly wired and grounded to prevent an electrical shock.

CAUTION

- Do not install a unit in a rack where the internal rack ambient temperatures will exceed the manufacturer's recommended ambient temperature for all your rack-mounted devices.
- Do not install a unit in a rack where the air flow is compromised. Ensure that air flow is not blocked or reduced on any side, front, or back of a unit used for air flow through the unit.
- Consideration should be given to the connection of the equipment to the supply circuit so that overloading of the circuits does not compromise the supply wiring or overcurrent protection. To provide the correct power connection to a rack, refer to the rating labels located on the equipment in the rack to determine the total power requirement of the supply circuit.
- *(For sliding drawers.)* Do not pull out or install any drawer or feature if the rack stabilizer brackets are not attached to the rack. Do not pull out more than one drawer at a time. The rack might become unstable if you pull out more than one drawer at a time.
- *(For fixed drawers.)* This drawer is a fixed drawer and must not be moved for servicing unless specified by the manufacturer. Attempting to move the drawer partially or completely out of the rack might cause the rack to become unstable or cause the drawer to fall out of the rack.

(R001)

CAUTION:

Removing components from the upper positions in the rack cabinet improves rack stability during relocation. Follow these general guidelines whenever you relocate a populated rack cabinet within a room or building:

- Reduce the weight of the rack cabinet by removing equipment starting at the top of the rack cabinet. When possible, restore the rack cabinet to the configuration of the rack cabinet as you received it. If this configuration is not known, you must observe the following precautions:
 - Remove all devices in the 32U position and above.
 - Ensure that the heaviest devices are installed in the bottom of the rack cabinet.
 - Ensure that there are no empty U-levels between devices installed in the rack cabinet below the 32U level.
- If the rack cabinet you are relocating is part of a suite of rack cabinets, detach the rack cabinet from the suite.
- Inspect the route that you plan to take to eliminate potential hazards.
- Verify that the route that you choose can support the weight of the loaded rack cabinet. Refer to the documentation that comes with your rack cabinet for the weight of a loaded rack cabinet.
- Verify that all door openings are at least 760 x 230 mm (30 x 80 in.).
- Ensure that all devices, shelves, drawers, doors, and cables are secure.
- Ensure that the four leveling pads are raised to their highest position.
- Ensure that there is no stabilizer bracket installed on the rack cabinet during movement.
- Do not use a ramp inclined at more than 10 degrees.
- When the rack cabinet is in the new location, complete the following steps:
 - Lower the four leveling pads.
 - Install stabilizer brackets on the rack cabinet.
 - If you removed any devices from the rack cabinet, repopulate the rack cabinet from the lowest position to the highest position.
- If a long-distance relocation is required, restore the rack cabinet to the configuration of the rack cabinet as you received it. Pack the rack cabinet in the original packaging material, or equivalent. Also lower the leveling pads to raise the casters off of the pallet and bolt the rack cabinet to the pallet.

(R002)

(L001)



(L002)



(L003)



or



All lasers are certified in the U.S. to conform to the requirements of DHHS 21 CFR Subchapter J for class 1 laser products. Outside the U.S., they are certified to be in compliance with IEC 60825 as a class 1 laser product. Consult the label on each part for laser certification numbers and approval information.

CAUTION:

This product might contain one or more of the following devices: CD-ROM drive, DVD-ROM drive, DVD-RAM drive, or laser module, which are Class 1 laser products. Note the following information:

- Do not remove the covers. Removing the covers of the laser product could result in exposure to hazardous laser radiation. There are no serviceable parts inside the device.
- Use of the controls or adjustments or performance of procedures other than those specified herein might result in hazardous radiation exposure.

(C026)

CAUTION:

Data processing environments can contain equipment transmitting on system links with laser modules that operate at greater than Class 1 power levels. For this reason, never look into the end of an optical fiber cable or open receptacle. (C027)

CAUTION:

This product contains a Class 1M laser. Do not view directly with optical instruments. (C028)

CAUTION:

Some laser products contain an embedded Class 3A or Class 3B laser diode. Note the following information: laser radiation when open. Do not stare into the beam, do not view directly with optical instruments, and avoid direct exposure to the beam. (C030)

CAUTION:

The battery contains lithium. To avoid possible explosion, do not burn or charge the battery.

Do Not:

- ___ Throw or immerse into water
- ___ Heat to more than 100°C (212°F)
- ___ Repair or disassemble

Exchange only with the IBM-approved part. Recycle or discard the battery as instructed by local regulations. In the United States, IBM has a process for the collection of this battery. For information, call 1-800-426-4333. Have the IBM part number for the battery unit available when you call. (C003)

Power and cabling information for NEBS (Network Equipment-Building System) GR-1089-CORE

The following comments apply to the IBM servers that have been designated as conforming to NEBS (Network Equipment-Building System) GR-1089-CORE:

The equipment is suitable for installation in the following:

- Network telecommunications facilities
- Locations where the NEC (National Electrical Code) applies

The intrabuilding ports of this equipment are suitable for connection to intrabuilding or unexposed wiring or cabling only. The intrabuilding ports of this equipment *must not* be metallically connected to the interfaces that connect to the OSP (outside plant) or its wiring. These interfaces are designed for use as intrabuilding interfaces only (Type 2 or Type 4 ports as described in GR-1089-CORE) and require isolation from the exposed OSP cabling. The addition of primary protectors is not sufficient protection to connect these interfaces metallically to OSP wiring.

Note: All Ethernet cables must be shielded and grounded at both ends.

The ac-powered system does not require the use of an external surge protection device (SPD).

The dc-powered system employs an isolated DC return (DC-I) design. The DC battery return terminal *shall not* be connected to the chassis or frame ground.

Installing the 5802 and 5877 expansion units

Use this overview as a guide to the tasks required for installing the 5802 and 5877 expansion units (12X I/O Drawer PCIe) into a rack and cabling it to a server.

You can use the following table to read about and complete the high-level tasks for installing the 5802 and 5877 expansion units.

Table 1. Tasks to install the expansion unit into a rack

Task	Where to find associated information
<p>Preinstalled enclosures only</p> <p>Remove the bracing bracket.</p> <p>After you have removed the bracing bracket, choose one of the following options:</p> <ul style="list-style-type: none"> • If you are installing the 5802 expansion unit, go to the task 5802 only: Connect the disk subsystem. • If you are installing the 5877 expansion unit, go to the task Add the expansion unit to the system and verify that the configuration is functional. 	<p>To remove the bracing bracket, see step 2 on page 3.</p>
<p>Perform inventory.</p> <p>Ensure that you have the rails.</p> <p>Ensure that you have both a Philips-head and flat-head screwdriver.</p>	<p>Locate the inventory list for your expansion unit, and verify that you received all of the parts that you ordered.</p> <p>Each order contains, at a minimum, the following items:</p> <ul style="list-style-type: none"> • Left and right rack-mounting rails • Mounting screws • Power supply cables <p>If your shipment contains parts that are not required to complete the installation procedure, store those parts until they are required to be used.</p> <p>If you have incorrect, missing, or damaged parts, consult any of the following resources:</p> <ul style="list-style-type: none"> • Your IBM reseller. • IBM Rochester manufacturing automated information at 1-800-300-8751 (United States only). • Directory of worldwide contacts (http://www.ibm.com/planetwide). Select your location to view the service and support contact information. <p>You can also obtain order information from your marketing representative or IBM Business Partner.</p>
<p>Check the firmware level for the server to which you are connecting the expansion unit.</p>	<p>To ensure that server firmware has been updated to a level that supports this expansion unit, see the IBM Prerequisite (https://www-912.ibm.com/e_dir/eserverprereq.nsf).</p>
<p>Verify that you have a rack.</p>	<p>You must have a rack installed. If you do not have a rack installed, see Installing the rack (http://publib.boulder.ibm.com/infocenter/systems/scope/hw/topic/p7hbf/installrack.htm).</p>

Table 1. Tasks to install the expansion unit into a rack (continued)

Task	Where to find associated information
Prepare to install the expansion unit.	To ensure that you have taken all preparatory steps to install this expansion unit, see Installing the 5802 or 5877 in a rack (http://publib.boulder.ibm.com/infocenter/systems/scope/hw/topic/p7ham/p7ham_5802_prepare.htm).
Determine where to install the expansion unit in the rack.	For suggestions about how to organize the hardware in your rack and to assign a location for the expansion unit, see step 5 on page 4.
Mark the location on the rack where the expansion unit will be installed.	If you have a rack-mounting template for the disk drive enclosure, use it to mark the location. If you do not have a rack-mounting template, see step 5d2 on page 5.
Install the rail assembly in the rack.	To install the mounting hardware in the rack, see step 6 on page 6.
Install the expansion unit on the rail assembly.	To install the expansion unit on the rail assembly, see step 7 on page 8.
5802 only Connect the disk subsystem.	To connect a SAS adapter to the disk drive enclosure as follows, see step 8c on page 16.
Add the expansion unit to the system and verify that the configuration is functional.	Add the expansion unit to the system by completing the following steps: 1. Read important information about expansion units at Overview for I/O expansion units (http://publib.boulder.ibm.com/infocenter/systems/scope/hw/topic/p7ham/p7ham_expunit_concepts.htm). 2. Complete the procedure for adding the expansion unit at Adding I/O expansion units (http://publib.boulder.ibm.com/infocenter/systems/scope/hw/topic/p7ham/iphamssetup_5802.htm).

Installing the 5802 and 5877 expansion units: Details

The detailed installation procedure includes information from online references that are specified in the overview. You can use the expanded instructions in this procedure to install your expansion unit into a rack and to cable it to a server.

- This information is provided in printed form as list of basic tasks for installing the 5802 and 5877 expansion units. For the most current version, use the online information: Installing the 5802 and 5877 expansion units (<http://publib.boulder.ibm.com/infocenter/systems/scope/hw/topic/p7ecy/p7ecy.pdf>).
- To ensure that server firmware has been updated to a level that supports this expansion unit, see the IBM Prerequisite (https://www-912.ibm.com/e_dir/eserverprereq.nsf).
- This procedure supports the following installation scenarios:
 - Your 5802 or 5877 expansion unit was delivered already mounted in a rack, and you must complete the installation.
 - Your 5802 or 5877 expansion unit was delivered separately from a rack, and you must mount the enclosure in an existing rack and complete the installation.

Note: If the rack is not yet installed, you must first complete the procedure for Installing the rack (<http://publib.boulder.ibm.com/infocenter/systems/scope/hw/topic/p7hbf/installrack.htm>).

- Before you install the expansion unit into a rack, read the Rack safety notices (<http://publib.boulder.ibm.com/infocenter/systems/scope/hw/topic/p7hbf/racksafety.htm>).

To install the 5802 or 5877 expansion unit, complete the following tasks:

1. Choose the type of installation you are completing:
 - To complete the installation of a 5802 or 5877 expansion unit that was delivered already mounted in a rack, go to step 2.
 - To complete the installation of a 5802 or 5877 expansion unit that was delivered separately from a rack, go to step 4 on page 4.
2. Remove the bracing bracket that is attached at the rear of the expansion unit as follows:
 - a. Loosen the captive thumbscrew on the retention bracket **(B)** that secures the shipping bracket **(A)** to the 5802 or 5877 expansion unit. Remove the retention bracket.

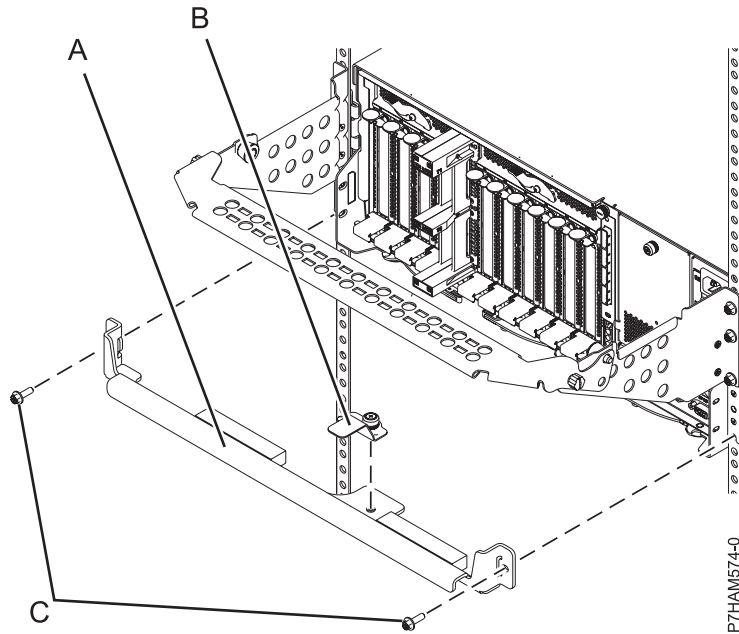

Figure 1. Removing the shipping and retention brackets

- b. Using a screwdriver, remove the screws (C) that attach the shipping bracket (A) to the left and right flanges of the rack frame. Lift the bracket out and away from the rack frame.

Tip: Save all of the bracket parts that you have removed for any future reinstallation and for shipping of the 5802 or 5877 expansion unit that might be required.

3. Go to step 8 on page 15.
4. Unpack the expansion unit as follows:
 - a. Refer to the kitting list provided with the rack installation kit, and complete a parts inventory.
 - b. Locate the rack-mounting hardware kit and the system rail assemblies that were included with your expansion unit.
5. Determine where to install the expansion unit into the rack as follows:
 - a. Determine where in the rack to place the expansion unit in relation to other system hardware. As you plan, keep the following steps in mind:
 - 1) Organize larger and heavier units into the lower part of the rack.
 - 2) Plan to install units into the lower part of the rack first.
 - 3) Record the EIA locations in your plan.

Note: The expansion unit is four Electronic Industries Alliance (EIA) units high. An EIA unit is 44.50 mm (1.75 in.) in height. The rack contains three mounting holes for each EIA unit of height. This enclosure, therefore, is 177.8 mm (7 in.) high and covers 12 mounting holes in the rack.

- b. If necessary, remove the filler panels to allow access to the inside of the rack enclosure where you plan to place the expansion unit.

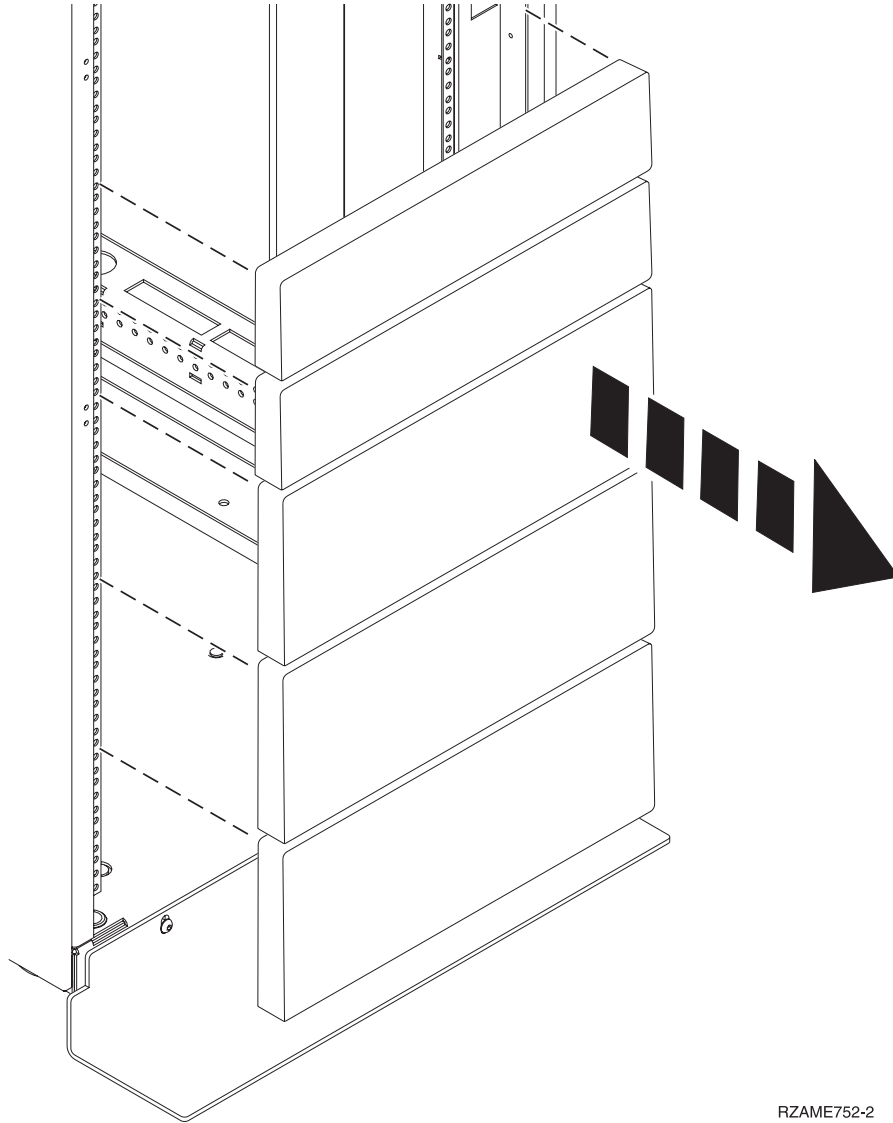

RZAME752-2

Figure 2. Removing the filler panels

- c. If necessary, remove the front and rear rack doors.
- d. Mark the rack location where you will install the expansion unit, by using one of the following methods:
 - 1) If you have a rack-mounting template, use it to mark the location.
 - 2) If you do not have a rack-mounting template, complete the following steps:
 - a) Face the front of the rack and work from the left side. Make a note of both the lowest and highest EIA units to be used for the expansion unit. Use tape, a marker, or a pencil to mark the bottom mounting hole (**A**) of the highest EIA unit. Mark the rack so that the mark can also be seen from the rear of the rack.

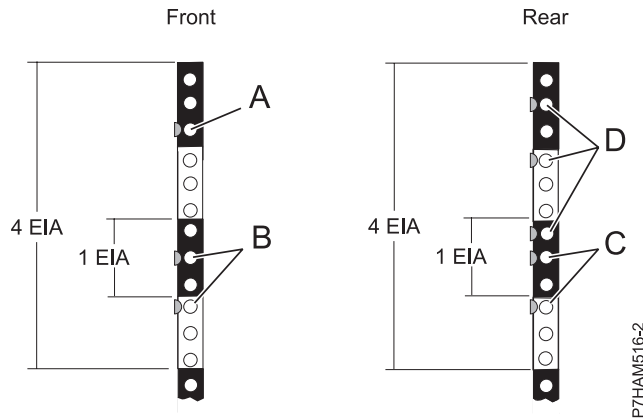

Figure 3. Marking the installation locations

- b) Mark the top mounting hole of the lowest EIA unit. Count up two holes and place another mark beside that mounting hole. Mark the rack so that these marks can also be seen from the rear of the rack. You now have two **(B)** marks on the rack, with one mounting hole between the marks.
 - c) Repeat the last two steps to place three marks on the corresponding mounting holes on the front-right side of the rack.
 - d) Go to the rear of the rack. On the left side, find the EIA unit that corresponds to the lowest EIA unit marked on the front of the rack.
 - e) Mark the top mounting hole of this EIA unit. Count up two holes and place another mark beside that mounting hole. You now have two **(C)** marks on the rack, with one mounting hole between the marks.
 - f) Count up one mounting hole from where you placed your last mark, and place another mark next to that mounting hole. Then count up three holes and place another mark beside that mounting hole. Then count up two holes and place another mark beside that mounting hole. You now have three **(D)** marks on the rack.
 - g) Repeat the last two steps to place five marks on the corresponding mounting holes on the rear-right side of the rack.
6. Install the rail assembly into the rack as follows:

Important: To complete this procedure, use two people to attach the rail assembly to the rack. Position one person in front of the rack and one person at the rear of the rack.

CAUTION:

Installing the rails in the rack is a complex procedure. To install the rails correctly, you must complete each task in the following order. Failure to do so might cause rail failure and potential danger to yourself and the system unit.

- a. Rotate down the front and back clamps **(C)** on the left and right rails, as shown in the following figure.
- b. On each rail, remove the tape holding the spring **(B)** to the rail. Hook the end of the spring around the circular standoff on the rail.
- c. Start at the front of the rack. Extend the right rail and insert the rail pins **(D)** into the two lowest mounting holes marked on the rack so that the rail is facing upward. Rotate up the front clamp **(C)** to secure the rail in place.

Notes:

- If your rack has the square mounting holes, remove the rail pins **(D)** from the rail. Install the larger rail pins provided with the rack installation kit.

- The rail installation can be completed by one person. However, the installation is easier if one person is positioned at the front of the rack and one person is positioned at the rear of the rack.

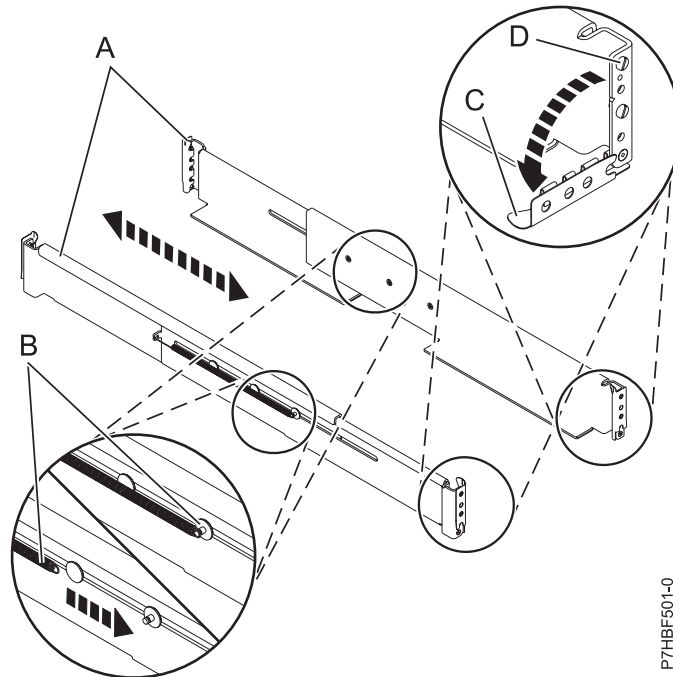

Figure 4. Installing the rails

- Extend the left rail and insert the rail pins (**D**) into the two lowest mounting holes marked on the rack. Rotate up the front clamp (**C**) to secure the rail in place.
- Move to the rear of the rack, extend the right rail, and insert the rail pins (**D**) into the two lowest mounting holes marked on the rack. Rotate up the back clamp (**C**) to secure the rail in place.
- Extend the left rail and insert the rail pins (**D**) into the two lowest mounting holes marked on the rack. Rotate up the back clamp (**C**) to secure the rail in place.
- At the rear of the rack, use two M5 screws (**E**), one below each rail pin (**D**), to secure the left rail to the back of the rack.
- Use two M5 screws (**E**), one below each rail pin (**D**), to secure the right rail to the back of the rack.
- Move to the front of the rack. Use one M5 screw (**E**) below the top rail pin to secure the left rail to the front of the rack.

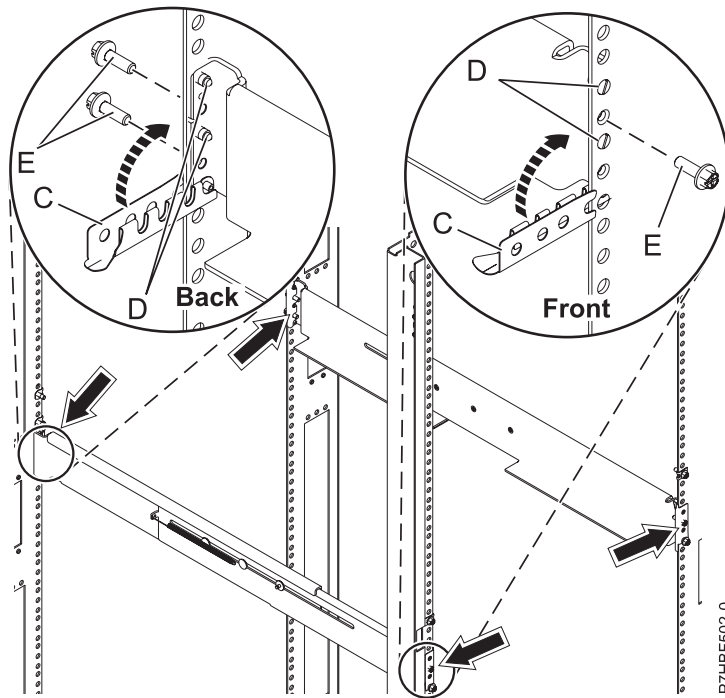

Figure 5. Attaching the rails

- j. Use one M5 screw (E), below the top rail pin (D), to secure the right rail to the front of the rack. See the previous figure.
 - k. Locate the remaining marks made previously on the front Electronic Industries Alliance (EIA) strips of the rack cabinet. Each side contains one mark. Insert a nut clip at these two locations.
 - l. From the back of the rack cabinet, locate the remaining marks made previously on the rear EIA strips. Each side contains three marks. Insert a nut clip these six locations.
7. Install the expansion unit onto the rails as follows:
- a. Remove the four thumb screws (B) that are used to secure the shipping cover (A) to the rear of the expansion unit, as shown in the following figure. Remove the shipping cover.

Note: The shipping cover is secured to the expansion unit by two thumb screws on the top of the cover and one thumb screw on each side.

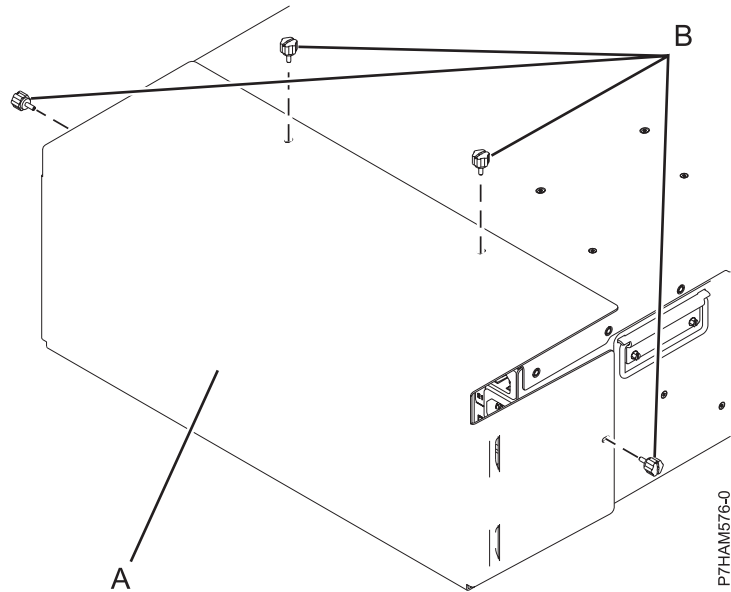

Figure 6. Removing the shipping cover

Tip: Save the shipping cover and screws that you have removed for any future shipping of the expansion unit that might be required.

- b. If the bezel is installed on the front of the system, remove it by completing the following steps:
 - 1) Remove the two M5 securing screws (A) as shown in Figure 7.
 - 2) Remove the service information holder from the slot in the bezel.
 - 3) Using the two blue touch points on each side of the expansion unit, pull the bezel straight out to remove the bezel from the front of the expansion unit.
 - 4) Remove the two nut clips that were used to secure the bezel to the expansion unit from the Electronic Industries Alliance (EIA) flange.

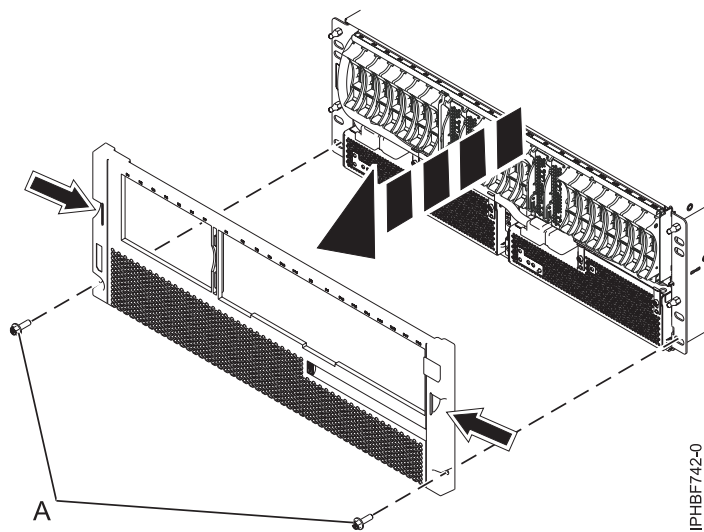

Figure 7. Removing the service information holder and bezel

- c. Using three people, hold onto the four handles (I), as shown in the following figure, to lift the expansion unit and position it over the front of the rails.

Attention: Three people are required to safely lift the expansion unit. Using fewer than three people to lift the expansion unit can result in injury.

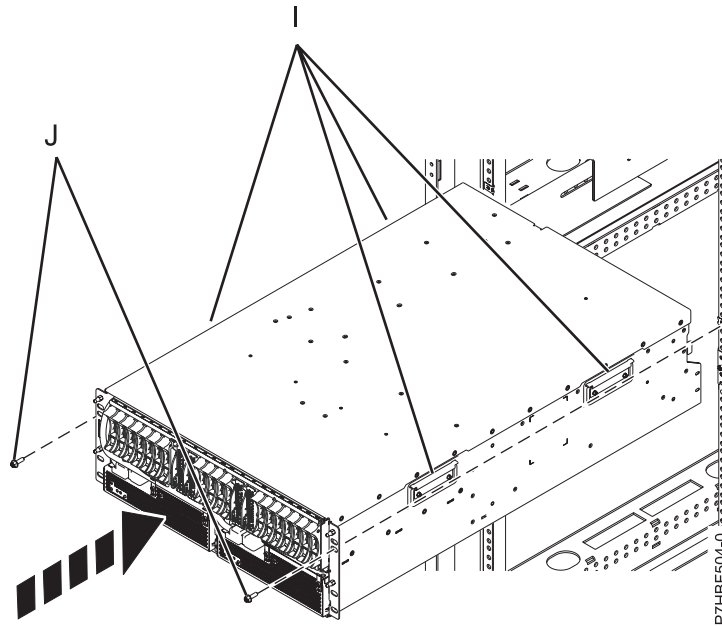

Figure 8. Installing the expansion unit into a rack

- d. Slide the expansion unit into the rack.
- e. Install the two M5 securing screws (**J**) through the expansion unit and into the nut clips on the left and right rails. See the previous figure.
- f. Install the bezel (**L**) onto the expansion unit. Press the bezel into place and secure it with two M5 screws (**M**) on the left and right rails. See the following figure.
- g. Insert the service information holder (**N**) into the slot in the bezel.

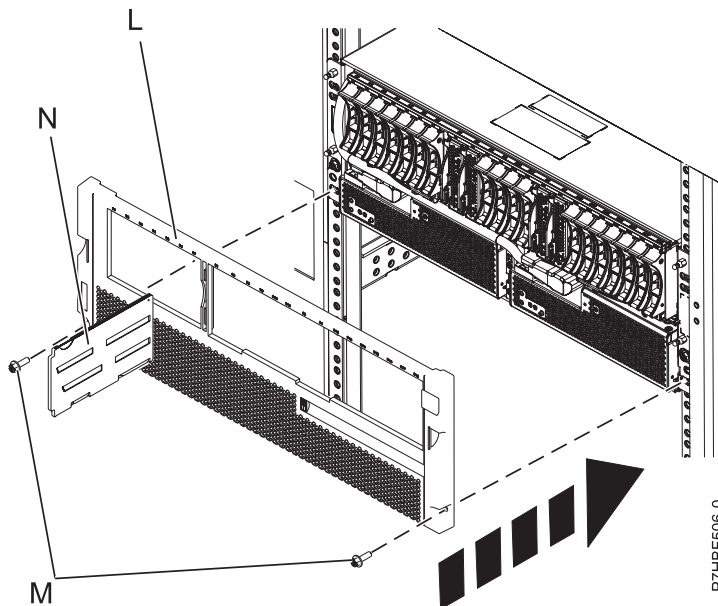

Figure 9. Installing the bezel and service information holder

- h. You must install either the cable management bracket or the retention brackets. Determine whether to install the cable management bracket or the retention bracket by reviewing the following information:
- Use the cable management bracket to secure the 5802 or 5877 expansion unit to the rack if you intend to provide extensive organization for the cables and cords connecting to the expansion unit. The cable management bracket contains a shelf that rotates into the following positions, as shown in Figure 10.
 - The shelf is rotated up to the highest position (1) to permit service of the 5802 or 5877 expansion unit. Since this position requires that the top edge of the shelf side brackets (A) be rotated fully below the plungers on the stationary arms (B), the shelf is not locked in this position.
 - The shelf is rotated to a level position (2) when no hardware service is being performed on the 5802 or 5877 expansion unit or adjacent hardware. The shelf side brackets (A) contain holes into which the plungers on the stationary arms (B) are inserted, enabling the shelf to lock in this position.
 - The shelf is rotated down to the next lower position (3) to permit service of hardware installed in the space directly above the 5802 or 5877 expansion unit. The shelf side brackets (A) contain holes into which the plungers on the stationary arms (B) are inserted, enabling the shelf to lock in this position.
 - The shelf is rotated down to the lowest position (4) if additional clearance space is needed to close the rear door of the rack. Since this position requires that the bottom edge of the shelf side brackets (A) be rotated fully above the plungers on the stationary arms (B), the shelf is not locked in this position.

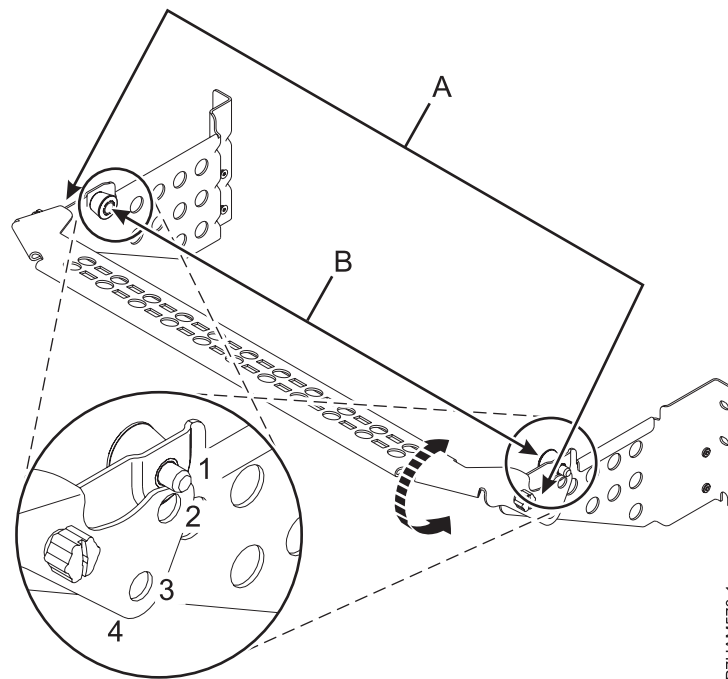

Figure 10. Positions of the cable management bracket rotation

Note: The cable management bracket is designed to function in racks with limited rear space. Following installation, it is normal for there to be limited clearance space between the bracket shelf and the rear door when the door is closed. It is normal for some contact to occur when doors containing shock padding are closed. However, if the door is prevented from full closure due to the thickness of certain padding features, such as the acoustic rear door, the shelf must be rotated to the lowest position (4) to allow the door to close.

Attention: The following situations might prevent the installation of the cable management bracket:

- The cable management bracket cannot be installed in the 25-EIA rack model (7014-S25) due to insufficient clearance space between the bracket shelf and door.
 - The cable management bracket cannot be installed with IBM features that require the same physical space, such as the earthquake kit.
 - The cable management bracket might not be able to be installed in racks containing additional customer hardware.
- Use the retention brackets to secure the 5802 or 5877 expansion unit to the rack when the use of the cable management bracket is restricted or not desired.
- i. Select one of the following options:
- If you are installing the cable management bracket, continue with step 7j.
 - If you are installing the retention brackets, continue with step 7m on page 13.
- j. The cable management bracket must be assembled before it can be installed. To assemble the cable management bracket, complete the following steps:
- 1) Locate the center shelf section (**B**) shown in the following figure, and identify the attachment hole that appears at each end of the piece.

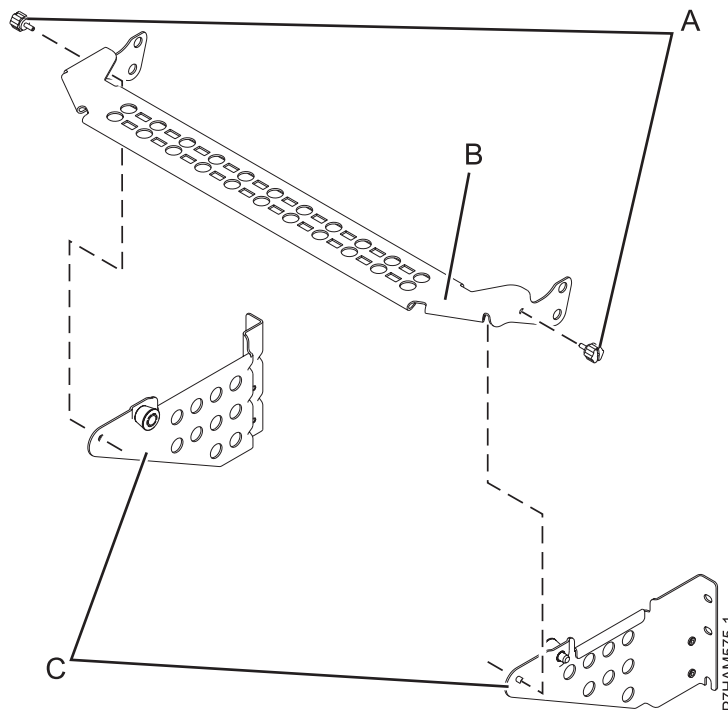

Figure 11. Assembling the cable management bracket

- 2) Choose one of the bracket side pieces (**C**), and identify the attachment point at its rounded tip. Use the previous figure to determine the end of the center shelf section to which it attaches.
 - 3) Align the attachment point of the bracket side piece to the inner side of the attachment hole of the center shelf section. Use one of the provided thumb screws (**A**) to secure the bracket side piece to the center shelf section.
 - 4) Use the remaining thumb screw to attach the second bracket side piece to the center shelf section.
- k. At the rear of the rack, hold the assembled cable management bracket so that its mounting flanges (**A**) align with holes in the rack flanges directly above the expansion unit rail clamps, as shown in Figure 12 on page 13. Attach each bracket mounting flange by applying M5 screws (**B**) to the three

locations above the rail clamp where nut clips have been installed.

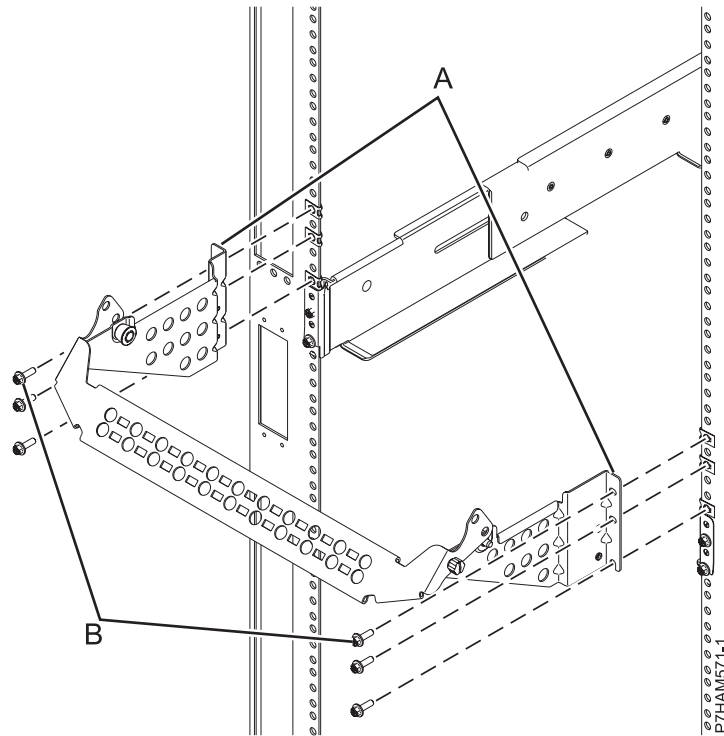

Figure 12. Installing the cable management bracket

- l. Continue with step 7n on page 14.
- m. At the rear of the rack, install retention brackets (**A**) on the left and right rack flanges, as shown in Figure 13 on page 14. Attach each bracket by applying M5 screws (**B**) to the two locations directly above the rail clamp where nut clips have been installed.

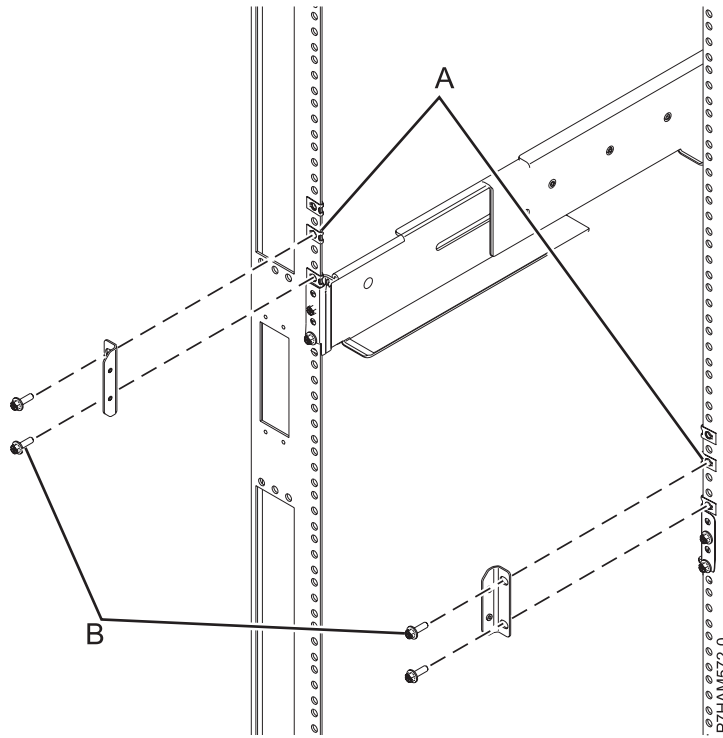

Figure 13. Installing the retention brackets

- n. Use one of the following options to secure the expansion unit to the rack:
- If you have installed the retention brackets, apply the four securing screws (**A**) as shown in Figure 14 on page 15.
 - If you have installed the cable management bracket, apply the four securing screws (**B**), as shown in Figure 14 on page 15.

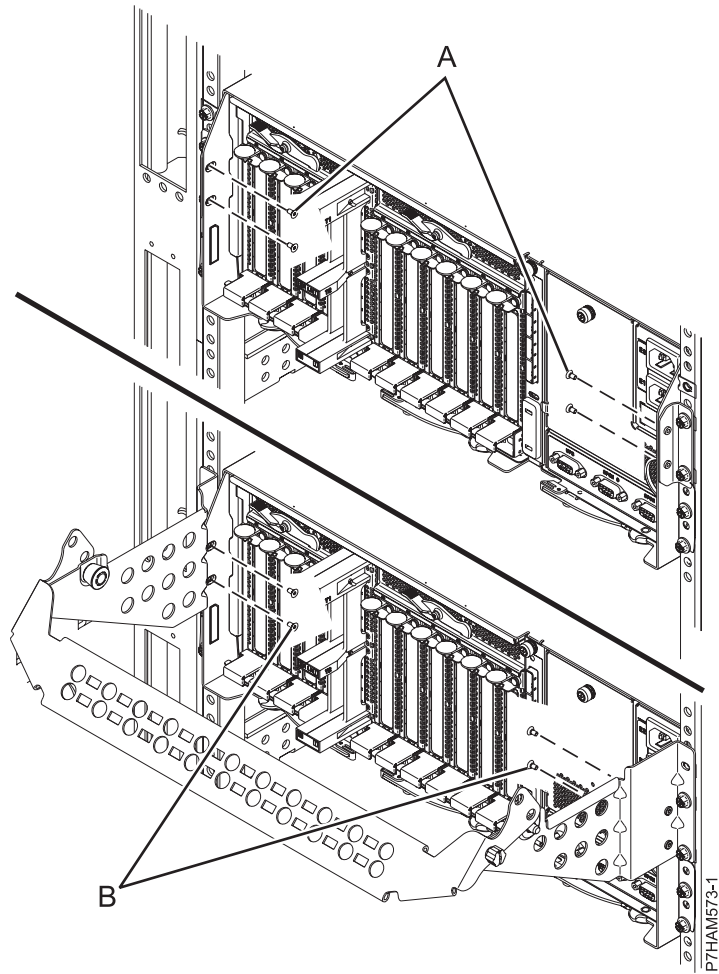

Figure 14. Applying the securing screws

8. Review the following information before connecting and configuring the hardware in your configuration:
 - a. Review the following connector locations figure for the 5802 and 5877.

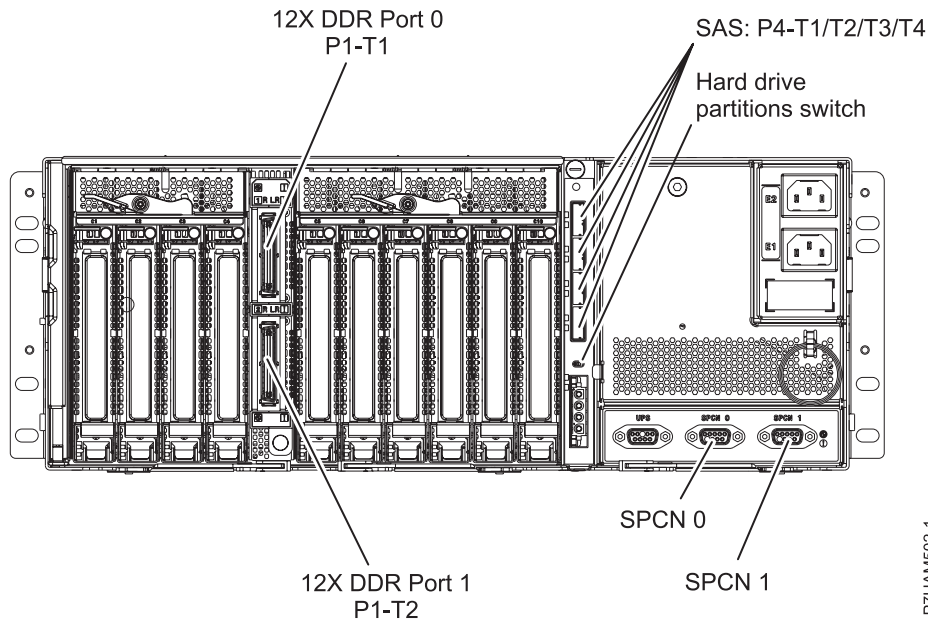

Figure 15. Model 5802 and 5877 connector locations

- b. Review connector information for the system. For details on systems connector locations, see “Server connectors” on page 27.
- c. **5802 only:** Review the following information about configuring the disk drive subsystem:
 - 1) The SAS disk subsystem in the 5802 expansion unit can hold up to 18 disk drives. The disks in this subsystem can be organized in several different configurations depending on the operating system used, the type of SAS adapter, and the position of the hard-disk-drive partitions switch.

Notes:

- The hard-disk-drive partitions switch is located at the rear of the 5802 expansion unit, just below the SAS connectors.
- If the hard-disk-drive partitions switch position is changed, you must power the 5802 expansion unit off and on in order for the 5802 to sense the new position of the hard-disk-drive partitions switch.

The SAS disk subsystem in the 5802 expansion unit is supported by the following operating systems:

- AIX®
- IBM i
- Linux
- VIOS

To determine the level of software you need to support the SAS disk subsystem in the 5802 expansion unit, see IBM Prerequisite (http://www-912.ibm.com/e_dir/eServerPrereq.nsf).

Table 2. Positions of the hard-disk-drive toggle switch

Operating system	Position 1	Position 2	Position 4
AIX	<p>Options:</p> <ul style="list-style-type: none"> • One FC 5901 adapter (PCIe Dual - x4 SAS) • One FC ESA1 adapter (PCIe2 RAID SAS Dual-port 6 Gb) • Two FC 5903/5805 adapters (PCIe Dual - x4 3 Gb SAS RAID) • Two FC ESA1 adapters (PCIe2 RAID SAS Dual-port 6 Gb) • Two FC 5913 adapters (PCIe2 1.8 GB cache RAID SAS Tri-port 6 Gb) <p>Note: The top ports of the FC 5913 pair must attach by a high-density (HD) SAS AA cable.</p>	<p>Options:</p> <ul style="list-style-type: none"> • Two FC 5901 adapters (PCIe Dual - x4 SAS) • Two FC 5903/5805 adapters (PCIe Dual - x4 3 Gb SAS RAID) • Two FC ESA1 adapters (PCIe2 RAID SAS Dual-port 6 Gb) • Two FC 5913 adapters (PCIe2 1.8 GB cache RAID SAS Tri-port 6 Gb) <p>Note: The top ports of the FC 5913 pair must attach by an HD SAS AA cable.</p>	<p>Options:</p> <ul style="list-style-type: none"> • Four single FC 5901 adapters (PCIe Dual - x4 SAS) • Four single FC ESA1 adapters (PCIe2 RAID SAS Dual-port 6 Gb)
IBM i	Not supported	<p>Options:</p> <ul style="list-style-type: none"> • Two single FC 5901 adapters (PCIe Dual - x4 SAS) • Two FC 5903/5805 adapters (PCIe Dual - x4 3 Gb SAS RAID) • Two FC ESA1 adapters (PCIe2 RAID SAS Dual-port 6 Gb) • Two FC 5913 adapters (PCIe2 1.8 GB cache RAID SAS Tri-port 6 Gb) <p>Note: The top ports of the FC 5913 pair must attach by an HD SAS AA cable.</p>	Not supported

Table 2. Positions of the hard-disk-drive toggle switch (continued)

Operating system	Position 1	Position 2	Position 4
Linux	<p>Options:</p> <ul style="list-style-type: none"> One FC 5901 adapter (PCIe Dual - x4 SAS) One FC ESA1 adapter (PCIe2 RAID SAS Dual-port 6 Gb) Two FC 5903/5805 adapters (PCIe Dual - x4 3 Gb SAS RAID) Two FC ESA1 adapters (PCIe2 RAID SAS Dual-port 6 Gb) Two FC 5913 adapters (PCIe2 1.8 GB cache RAID SAS Tri-port 6 Gb) <p>Note: The top ports of the FC 5913 pair must attach by an HD SAS AA cable.</p>	<p>Options:</p> <ul style="list-style-type: none"> Two FC 5901 adapters (PCIe Dual - x4 SAS) Two FC 5903/5805 adapters (PCIe Dual - x4 3 Gb SAS RAID) Two FC ESA1 adapters (PCIe2 RAID SAS Dual-port 6 Gb) Two FC 5913 adapters (PCIe2 1.8 GB cache RAID SAS Tri-port 6 Gb) <p>Note: The top ports of the FC 5913 pair must attach by an HD SAS AA cable.</p>	<p>Options:</p> <ul style="list-style-type: none"> Four single FC 5901 adapters (PCIe Dual - x4 SAS) Four single FC ESA1 adapters (PCIe2 RAID SAS Dual-port 6 Gb)
<p>Note: FC means feature code.</p>			

Tip: If you are planning to configure RAID arrays, ensure that you have the minimum number of available disks for each RAID level:

RAID 0

Minimum of one drive per array

RAID 5

Minimum of three drives per array

RAID 6

Minimum of four drives per array

RAID 10

Minimum of two drives per array

For additional SAS RAID controller information for the AIX operating system, see SAS RAID controller for AIX (<http://publib.boulder.ibm.com/infocenter/systems/scope/hw/topic/p7ebj/p7ebjkickoff.htm>).

For additional SAS RAID controller information for the IBM i operating system, see SAS RAID controllers for IBM i (<http://publib.boulder.ibm.com/infocenter/systems/scope/hw/topic/p7ed5/p7ed5kickoff.htm>).

For additional SAS RAID controller information for the Linux operating system, see SAS RAID controller for Linux (<http://publib.boulder.ibm.com/infocenter/systems/scope/hw/topic/p7ebk/p7ebkkickoff.htm>).

For information related to device parity protection, see Device parity protection (<http://publib.boulder.ibm.com/infocenter/systems/scope/i5os/topic/rzaly/rzalydpy.htm>).

- a. Select one of the following configurations to cable the disk subsystem in the 5802 expansion unit.

Note: When connecting any multi-initiator configuration that includes dual SAS adapters, ensure that all of the same disk devices are attached to both adapters and that the disk devices are cabled to the same numbered ports on each adapter.

- To cable a configuration that includes two hard-disk-drive partitions, nine disks per hard-disk-drive partition, and a dual SAS adapter pair with connectivity to all drives, go to step 1b.

Notes:

- This is a multi-initiator high-availability configuration.
- This configuration can be used with the following operating systems: AIX, IBM i, Linux
- To cable a configuration that includes one hard-disk-drive partition, 18 disks, and one SAS adapter, go to step 1c on page 20.

Note: This configuration can be used with the following operating systems: AIX, Linux

- To cable a configuration that includes two hard-disk-drive partitions, nine disks per hard-disk-drive partition, and one SAS adapter, go to step 1d on page 21.

Note: This configuration can be used with the following operating systems: AIX, IBM i, Linux

- To cable a configuration that includes two hard-disk-drive partitions, nine disks per hard-disk-drive partition, and two SAS adapters, go to step 1e on page 22.

Note: This configuration can be used with the following operating systems: AIX, IBM i, Linux

- To cable a configuration that includes two hard-disk-drive partitions, nine disks per hard-disk-drive partition, a dual SAS adapter pair per hard-disk-drive partition that controls the disks in the partition, and dual SAS connectivity to all drives, go to step 1f on page 22.

Notes:

- This is a multi-initiator high-availability configuration.
- This configuration can be used with the following operating systems: AIX, IBM i, Linux
- To cable a configuration that includes one hard-disk-drive partition, 18 disks, and a dual SAS adapter pair with connectivity to all drives, go to step 1g on page 23.

Notes:

- This is a multi-initiator high-availability configuration.
- This configuration can be used with the following operating systems: AIX, Linux
- To cable a configuration that includes four hard-disk-drive partitions, 18 disks, and one SAS adapter per hard-disk-drive partition, go to step 1h on page 24.

Notes:

- The 18 disks in this configuration are divided among the four hard-disk-drive partitions as follows:
 - Partition 1: Disk drives 01 - 05.
 - Partition 2: Disk drives 06 - 09.
 - Partition 3: Disk drives 10 - 14.
 - Partition 4: Disk drives 15 - 18.
- This configuration is optimized for boot partitions.
- This configuration can be used with the following operating systems: AIX, Linux

- b. Complete the following steps to cable a configuration that includes two hard-disk-drive partitions, nine disks per hard-disk-drive partition, and a dual SAS adapter pair with connectivity to all drives.

Notes:

- For the following operating systems, this must be a RAID configuration: AIX, Linux
 - You must have a minimum of one disk drive per hard-disk-drive partition.
- 1) Set the hard-disk-drive partitions switch to position 2. The hard-disk-drive partitions switch is located at the rear of the 5802 expansion unit, just below the SAS connectors.
 - 2) Choose one of the following SAS adapter and cable combination options:
 - Two FC ESA1 adapters (PCIe2 RAID SAS Dual-port 6 Gb) cabled with four FC 3689 cables (AT 0.6 meter - HD SAS)
 - Two FC 5805 or FC 5903 adapters (PCIe Dual - x4 3 Gb SAS RAID) cabled with four FC 3688 cables (AT 0.6 meter - Mini SAS)
 - Two FC 5901 adapters (PCIe Dual - x4 SAS) cabled with four FC 3688 cables (AT 0.6 meter - Mini SAS)

Note: Dual FC 5901 adapters are not supported in IBM i.

- Two FC 5913 adapters (PCIe2 1.8 GB cache RAID SAS Tri-port 6 Gb) cabled with four FC 3689 cables (AT 0.6 meter - HD SAS)

Note: The top ports of the FC 5913 pair must attach by an HD SAS AA cable.

- 3) Attach an AT cable (**B**) from the same numbered port on each SAS adapter (**A**) of a dual SAS adapter pair to SAS connectors 1 and 2 on the 5802 SAS conduit card (**C**), as shown in the following figure.

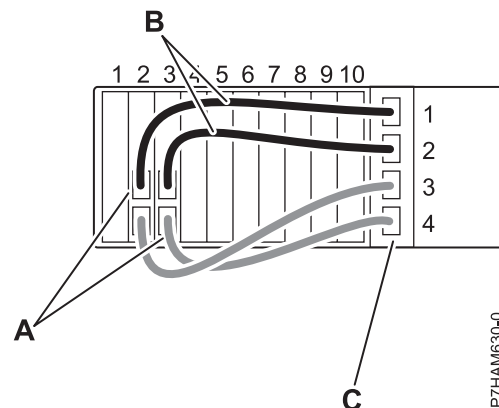

Figure 16. Configuration with two hard-disk-drive partitions that have dual SAS connectivity in a multi-initiator high-availability configuration

- 4) Attach an AT cable (**B**) from other same numbered ports on the same adapter pair (**A**) to SAS connectors 3 and 4 on the 5802 SAS conduit card (**C**).
 - 5) Go to step 1i on page 25.
- c. Complete the following steps to cable a configuration that includes one hard-disk-drive partition, 18 disks, and one SAS adapter.
- 1) Set the hard-disk-drive partitions switch to position 1. The hard-disk-drive partitions switch is located at the rear of the 5802 expansion unit, just below the SAS connectors.
 - 2) Choose one of the following SAS adapter and cable combination options:
 - One FC ESA1 adapter (PCIe2 RAID SAS Dual-port 6 Gb) cabled with one FC 3689 cable (AT 0.6 meter - HD SAS)
 - One FC 5901 adapter (PCIe Dual - x4 SAS) cabled with one FC 3688 cable (AT 0.6 meter - Mini SAS)

- 3) Attach an AT cable (B) from a port on a SAS adapter (A) to SAS connector 1 on the 5802 SAS conduit card (C), as shown in the following figure.

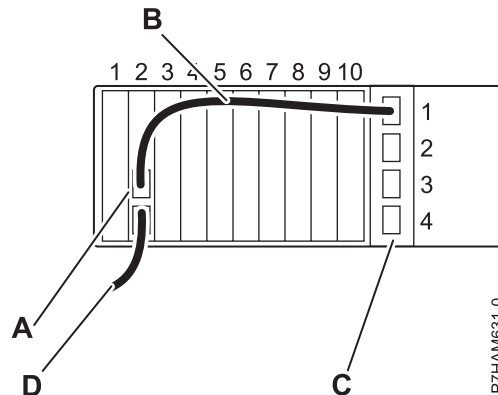

Figure 17. Configuration with one hard-disk-drive partition and one SAS adapter

- 4) Optional: Use another port on the same SAS adapter to connect a 5886 disk drive enclosure or 5887 disk drive enclosure by using a SAS YO cable (D).
 - 5) Go to step 1i on page 25.
- d. Complete the following steps to cable a configuration that includes two hard-disk-drive partitions, nine disks per hard-disk-drive partition, and one SAS adapter.

Note: You must have a minimum of one disk drive per hard-disk-drive partition.

- 1) Set the hard-disk-drive partitions switch to position 2. The hard-disk-drive partitions switch is located at the rear of the 5802 expansion unit, just below the SAS connectors.
- 2) Choose one of the following SAS adapter and cable combination options:
 - One FC ESA1 adapter (PCIe2 RAID SAS Dual-port 6 Gb) cabled with two FC 3689 cables (AT 0.6 meter - HD SAS)
 - One FC 5901 adapter (PCIe Dual - x4 SAS) cabled with two FC 3688 cables (AT 0.6 meter - Mini SAS)
- 3) Attach an AT cable (B) from one port on the SAS adapter (A) to SAS connector 1 on the 5802 SAS conduit card (C), as shown in the following figure.

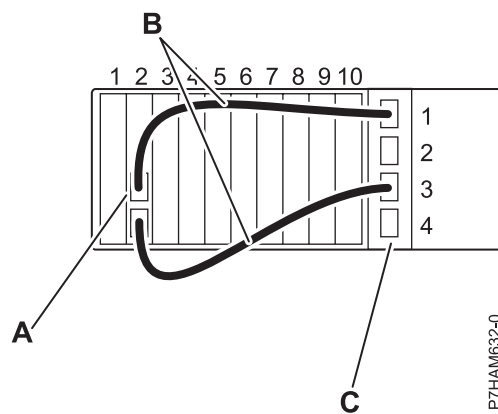

Figure 18. Configuration with two hard-disk-drive partitions and one SAS adapter

- 4) Attach an AT cable (B) from another port on the SAS adapter (A) to SAS connector 1 on the 5802 SAS conduit card (C).
- 5) Go to step 1i on page 25.

- e. Complete the following steps to cable a configuration that includes two hard-disk-drive partitions, nine disks per hard-disk-drive partition, and two SAS adapters.

Note: You must have a minimum of one disk drive per hard-disk-drive partition.

- 1) Set the hard-disk-drive partitions switch to position 2. The hard-disk-drive partitions switch is located at the rear of the 5802 expansion unit, just below the SAS connectors.
- 2) Choose one of the following SAS adapter and cable combination options:
 - Two FC ESA1 adapters (PCIe2 RAID SAS Dual-port 6 Gb) cabled with two FC 3689 cables (AT 0.6 meter - HD SAS)
 - Two FC 5901 adapters (PCIe Dual - x4 SAS) cabled with two FC 3688 cables (AT 0.6 meter - Mini SAS)
- 3) Attach an AT cable (**B**) from one port on one SAS adapter (**A**) to SAS connector 1 on the 5802 SAS conduit card (**C**), as shown in the following figure.

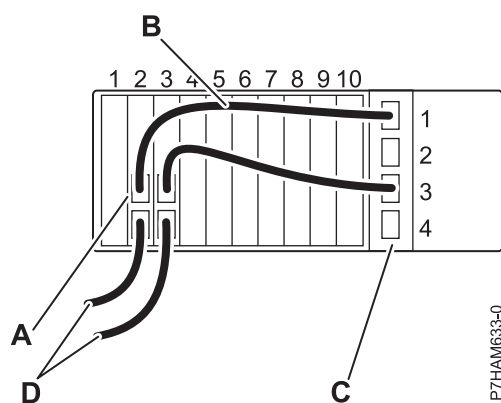

Figure 19. Configuration with two hard-disk-drive partitions and two SAS adapters

- 4) Attach an AT cable (**B**) from one port on the other SAS adapter (**A**) to SAS connector 3 on the 5802 SAS conduit card (**C**).
 - 5) Optional: Use other ports on the same SAS adapters to connect a 5886 disk drive enclosure or 5887 disk drive enclosure by using SAS YO cables (**D**).
 - 6) Go to step 1i on page 25.
- f. Complete the following steps to cable a configuration that includes two hard-disk-drive partitions, nine disks per hard-disk-drive partition, a dual SAS adapter pair per hard-disk-drive partition that controls the disks in the partition, and dual SAS connectivity to all drives.

Notes:

- For the following operating systems, this configuration must be a RAID configuration: AIX, Linux
 - You must have a minimum of one disk drive per hard-disk-drive partition.
- 1) Set the hard-disk-drive partitions switch to position 2. The hard-disk-drive partitions switch is located at the rear of the 5802 expansion unit, just below the SAS connectors.
 - 2) Choose one of the following SAS adapter and cable combination options:
 - Four FC ESA1 adapters (PCIe2 RAID SAS Dual-port 6 Gb) cabled with four FC 3689 cables (AT 0.6 meter - HD SAS)
 - Four FC 5805 or FC 5903 adapters (PCIe Dual - x4 3 Gb SAS RAID) cabled with four FC 3688 cables (AT 0.6 meter - Mini SAS)
 - Four FC 5901 adapters (PCIe Dual - x4 SAS) cabled with four FC 3688 cables (AT 0.6 meter - Mini SAS)

Note: Dual FC 5901 adapters are not supported in IBM i.

- Four FC 5913 adapters (PCIe2 1.8 GB cache RAID SAS Tri-port 6 Gb) cabled with four FC 3689 cables (AT 0.6 meter - HD SAS)

Note: The top ports of the FC 5913 pair must attach by an HD SAS AA cable.

- 3) Attach an AT cable (**B**) from the same numbered port on each SAS adapter (**A**) of the first dual SAS adapter pair to SAS connectors 1 and 2 on the 5802 SAS conduit card (**C**), as shown in the following figure.

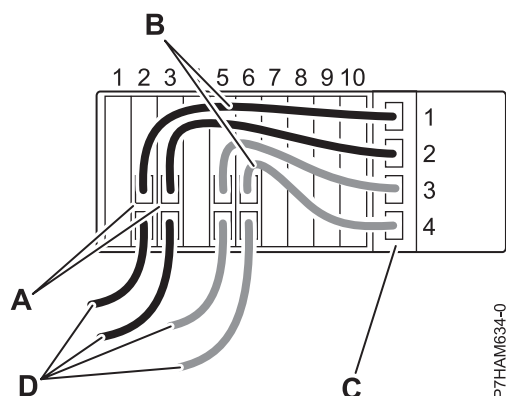

Figure 20. Configuration with two hard-disk-drive partitions that have dual SAS connectivity in a multi-initiator high-availability configuration

- 4) Attach an AT cable (**B**) from the same numbered port on each SAS adapter of the second dual SAS adapter pair to SAS connectors 3 and 4 on the 5802 SAS conduit card (**C**).
 - 5) Optional: Use other ports on the same SAS adapter pair to connect a 5886 disk drive enclosure by using SAS X cables or to connect a 5887 disk drive enclosure by using SAS YO cables (**D**). Both ports from the same adapter pair must be connected to the same disk drive enclosure.
 - 6) Go to step 1i on page 25.
- g. Complete the following steps to cable a configuration that includes one hard-disk-drive partition, 18 disks, and a dual SAS adapter pair with connectivity to all drives.

Note: For the following operating systems, this must be a RAID configuration: AIX, Linux

- 1) Set the hard-disk-drive partitions switch to position 1. The hard-disk-drive partitions switch is located at the rear of the 5802 expansion unit, just below the SAS connectors.
- 2) Choose one of the following SAS adapter and cable combination options:
 - Two FC ESA1 adapters (PCIe2 RAID SAS Dual-port 6 Gb) cabled with two FC 3689 cables (AT 0.6 meter - HD SAS)
 - Two FC 5805 or FC 5903 adapters (PCIe Dual - x4 3 Gb SAS RAID) cabled with two FC 3688 cables (AT 0.6 meter - Mini SAS)
 - Two FC 5901 adapters (PCIe Dual - x4 SAS) cabled with two FC 3688 cables (AT 0.6 meter - Mini SAS)
 - Two FC 5913 adapters (PCIe2 1.8 GB cache RAID SAS Tri-port 6 Gb) cabled with two FC 3689 cables (AT 0.6 meter - HD SAS)

Note: The top ports of the FC 5913 pair must attach by an HD SAS AA cable.

- 3) Attach an AT cable (**B**) from the same numbered port on each SAS adapter (**A**) of a dual SAS adapter pair to SAS connectors 1 and 2 on the 5802 SAS conduit card (**C**), as shown in the following figure.

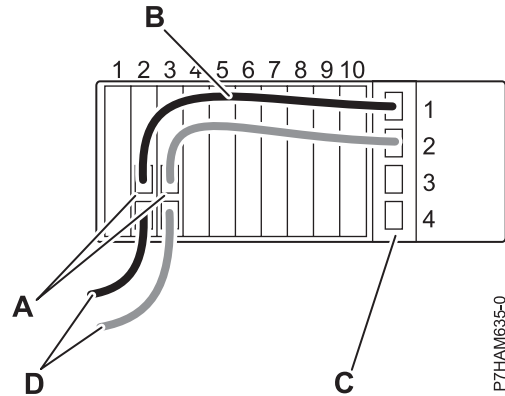

Figure 21. Configuration with a hard-disk-drive partition that has dual SAS connectivity in a multi-initiator high-availability configuration

- 4) Optional: Use other ports on the same SAS adapter pair to connect a 5886 disk drive enclosure by using a SAS X cable or to connect a 5887 disk drive enclosure by using SAS YO cables (**D**). Both ports from the same adapter pair must be connected to the same disk drive enclosure.
- 5) Go to step 1i on page 25.
- h. Complete the following steps to cable a configuration that includes four hard-disk-drive partitions, 18 disks, and one SAS adapter per hard-disk-drive partition.

Note: The 18 disks in this configuration are divided among the four hard-disk-drive partitions as follows:

- Partition 1: Disk drives 01 - 05.
- Partition 2: Disk drives 06 - 09.
- Partition 3: Disk drives 10 - 14.
- Partition 4: Disk drives 15 - 18.

- 1) Set the hard-disk-drive partitions switch to position 4. The hard-disk-drive partitions switch is located at the rear of the 5802 expansion unit, just below the SAS connectors.
- 2) Choose one of the following SAS adapter and cable combination options:

Note: You must provide an adapter and cable combination for each of the four disk partitions that has an installed disk drive.

- One FC ESA1 adapter (PCIe2 RAID SAS Dual-port 6 Gb) cabled with one FC 3689 cable (AT 0.6 meter - HD SAS)
 - One FC 5901 adapter (PCIe Dual - x4 SAS) cabled with one FC 3688 cable (AT 0.6 meter - Mini SAS)
- 3) Attach an AT cable (**B**) from one port on each SAS adapter (**A**) to a SAS connector on the 5802 SAS conduit card (**C**), as shown in the following figure.

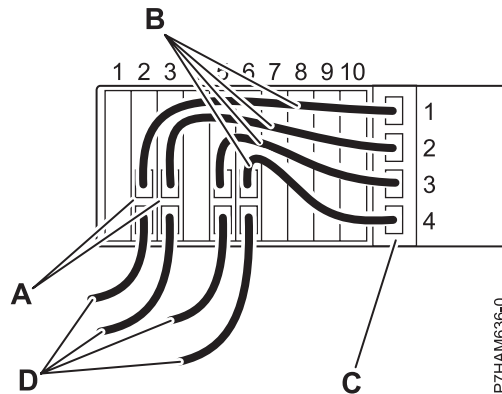

Figure 22. Configuration with four hard-disk-drive partitions that have four SAS adapters

- 4) Optional: Use other ports on the SAS adapters to connect a 5886 disk drive enclosure or a 5887 disk drive enclosure by using SAS YO cables (**D**).
- 5) Go to step 1i.
 - i. If the configuration that you chose required the hard-disk-drive partitions switch to be set to a different position, activate the new setting by powering off and powering on the 5802 expansion unit.
9. Add the expansion unit to the system by completing the following steps:
 - a. Read important information about expansion units at Overview for I/O expansion units (http://publib.boulder.ibm.com/infocenter/systems/scope/hw/topic/p7ham/p7ham_expunit_concepts.htm).
 - b. Complete the procedure for adding the expansion unit at Adding I/O expansion units (http://publib.boulder.ibm.com/infocenter/systems/scope/hw/topic/p7ham/iphamssetup_5802.htm).

Reference information

Use the information in this section as needed to complete enclosure installation and configuration tasks.

Connector locations

Learn about 12X, system power control network (SPCN), and PCIe connector locations.

Server connectors

Learn about connector locations for servers.

Model 8202-E4B connector locations

Learn about connector locations on rack-mounted and stand-alone models.

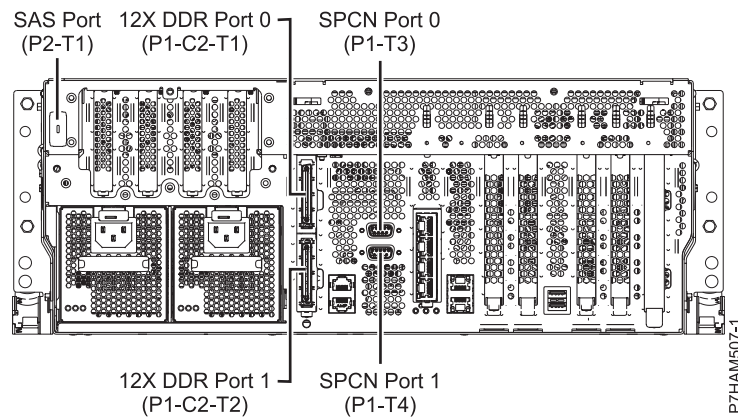

Figure 23. Model 8202-E4B connector locations on a rack-mounted model

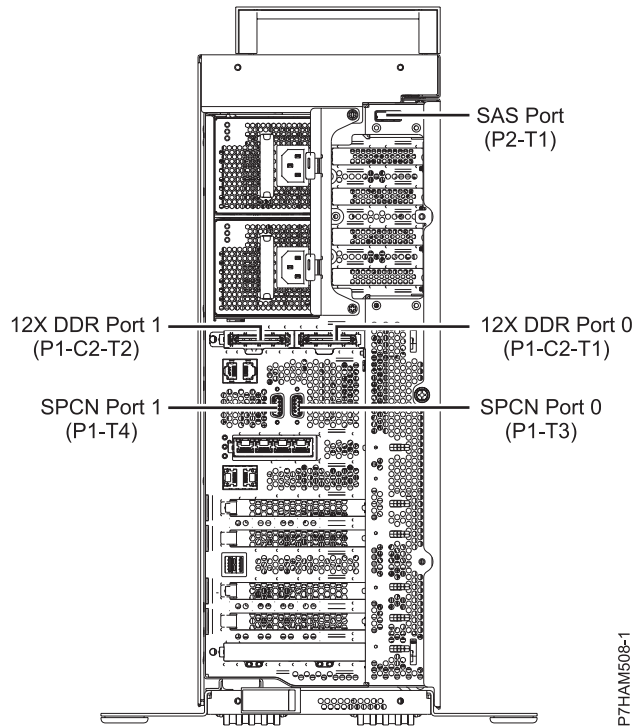

Figure 24. Model 8202-E4B connector locations on a stand-alone model

Model 8202-E4C connector locations

Learn about connector locations on rack-mounted models.

The 8202-E4C server provides cable connector locations for the following enclosures:

- Support for expansion units, as shown in the following figure, is as follows:
 - The card installed in the C1 slot can contain two 12X double data rate (DDR) cable ports. However, the C1 slot cannot provide both 12X DDR and PCIe cable ports.
 - The server contains a serial-attached SCSI (SAS) port.
- Support for disk drive enclosures, as shown in the following figure, is as follows:
 - The server contains a SAS port.
- Support for PCIe storage enclosures, as shown in the following figure, is as follows:
 - The card installed in the C1 slot can contain two PCIe cable ports. However, the C1 slot cannot provide both PCIe and 12X DDR cable ports.
 - The server contains a SAS port.

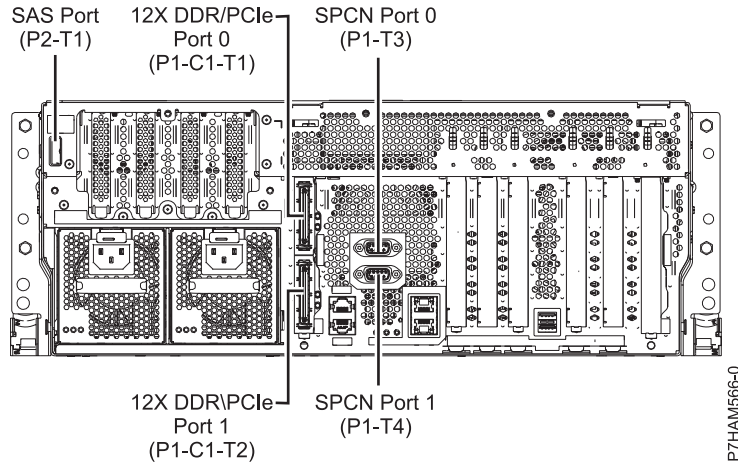

Figure 25. Model 8202-E4C connections for expansion units, disk drive enclosures, and PCIe storage enclosures

Model 8202-E4D connector locations

Learn about connector locations on rack-mounted models.

The 8202-E4D server provides cable connector locations for the following enclosures:

- Support for expansion units, as shown in the following figure, is as follows:
 - The card installed in the C1 slot can contain two 12X double data rate (DDR) cable ports. However, the C1 slot cannot provide both 12X DDR and PCIe cable ports.
 - The server contains a serial-attached SCSI (SAS) port.
- Support for disk drive enclosures, as shown in the following figure, is as follows:
 - The server contains a SAS port.
- Support for PCIe storage enclosures, as shown in the following figure, is as follows:
 - The card installed in the C1 slot can contain two PCIe cable ports. However, the C1 slot cannot provide both PCIe and 12X DDR cable ports.
 - The server contains a SAS port.

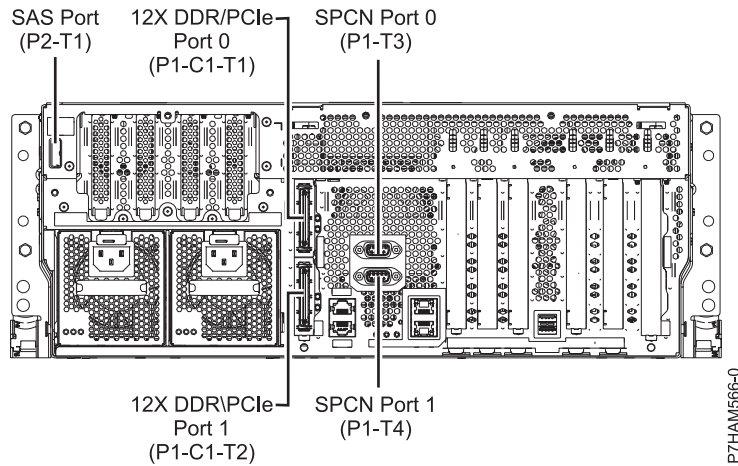

Figure 26. Model 8202-E4D connections for expansion units, disk drive enclosures, and PCIe storage enclosures

Model 8205-E6B connector locations

Learn about connector locations on rack-mounted and stand-alone models.

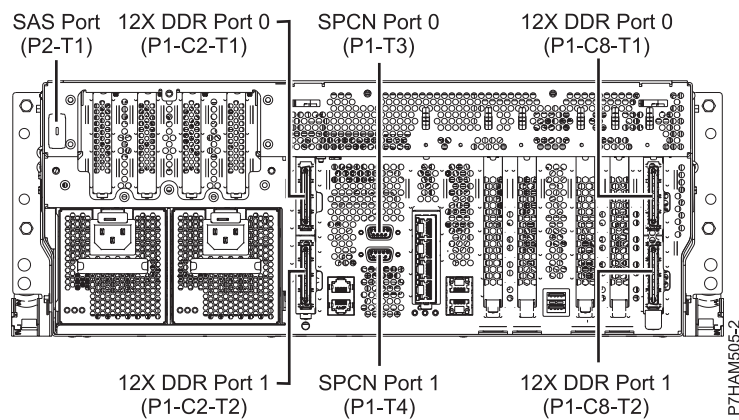

Figure 27. Model 8205-E6B connector locations on a rack-mounted model

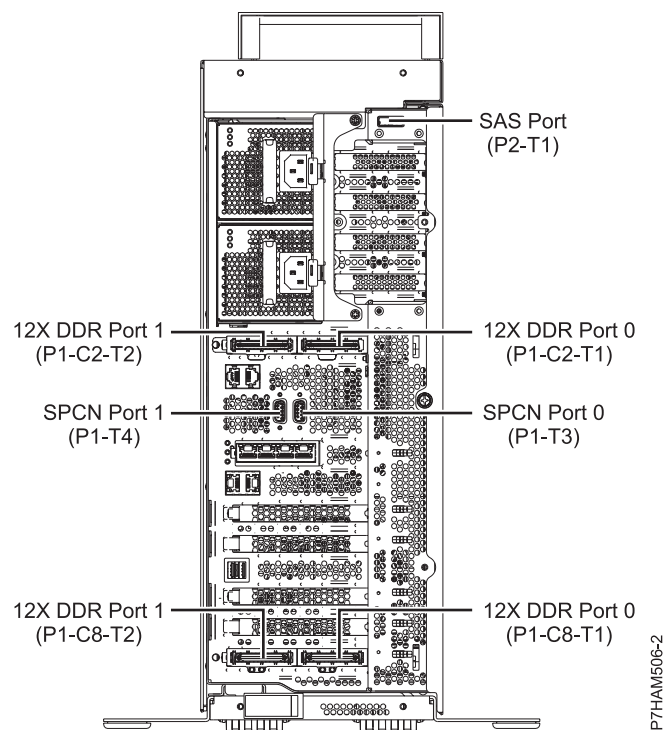

Figure 28. Model 8205-E6B connector locations on a stand-alone model

Model 8205-E6C connector locations

Learn about connector locations on rack-mounted models.

The 8205-E6C server provides cable connector locations for the following enclosures:

- Support for expansion units, as shown in the following figure, is as follows:
 - The card installed in the C1 slot can contain two 12X double data rate (DDR) cable ports. However, the C1 slot cannot provide both 12X DDR and PCIe cable ports.

- The card installed in the C8 slot can contain two 12X DDR cable ports. However, the C8 slot cannot provide both 12X DDR and PCIe cable ports.
- The port card type installed in the C1 slot can differ from the port card type installed in the C8 slot.
- The server contains a serial-attached SCSI (SAS) port.
- Support for disk drive enclosures, as shown in the following figure, is as follows:
 - The server contains a SAS port.
- Support for PCIe storage enclosures, as shown in the following figure, is as follows:
 - The card installed in the C1 slot can contain two PCIe cable ports. However, the C1 slot cannot provide both PCIe and 12X DDR cable ports.
 - The card installed in the C8 slot can contain two PCIe cable ports. However, the C8 slot cannot provide both PCIe and 12X DDR cable ports.
 - The port card type installed in the C1 slot can differ from the port card type installed in the C8 slot.
 - The server contains a SAS port.

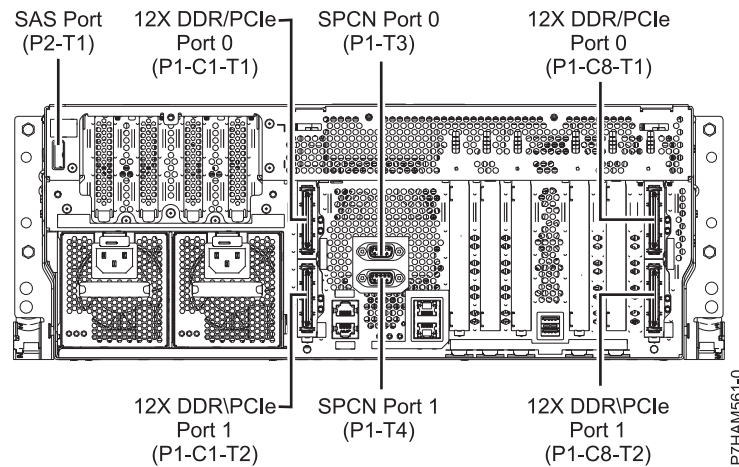

Figure 29. Model 8205-E6C connections for expansion units, disk drive enclosures, and PCIe storage enclosures

Model 8205-E6D connector locations

Learn about connector locations on rack-mounted models.

The 8205-E6D server provides cable connector locations for the following enclosures:

- Support for expansion units, as shown in the following figure, is as follows:
 - The card installed in the C1 slot can contain two 12X double data rate (DDR) cable ports. However, the C1 slot cannot provide both 12X DDR and PCIe cable ports.
 - The card installed in the C8 slot can contain two 12X DDR cable ports. However, the C8 slot cannot provide both 12X DDR and PCIe cable ports.
 - The port card type installed in the C1 slot can differ from the port card type installed in the C8 slot.
 - The server contains a serial-attached SCSI (SAS) port.
- Support for disk drive enclosures, as shown in the following figure, is as follows:
 - The server contains a SAS port.
- Support for PCIe storage enclosures, as shown in the following figure, is as follows:
 - The card installed in the C1 slot can contain two PCIe cable ports. However, the C1 slot cannot provide both PCIe and 12X DDR cable ports.
 - The card installed in the C8 slot can contain two PCIe cable ports. However, the C8 slot cannot provide both PCIe and 12X DDR cable ports.
 - The port card type installed in the C1 slot can differ from the port card type installed in the C8 slot.

- The server contains a SAS port.

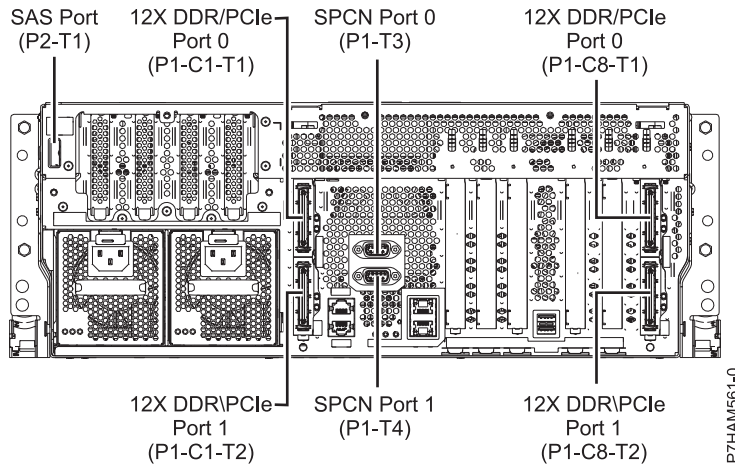

Figure 30. Model 8205-E6D connections for expansion units, disk drive enclosures, and PCIe storage enclosures

Model 8231-E1C connector locations

Learn about connector locations.

The 8231-E1C server provides cable connector locations for the following enclosures:

- Support for disk drive enclosures, as shown in the following figure, is as follows:
 - The server contains a serial-attached SCSI (SAS) port.
- Support for PCIe storage enclosures, as shown in the following figure, is as follows:
 - The card installed in the C1 slot can contain one PCIe cable port.
 - The server contains a SAS port.

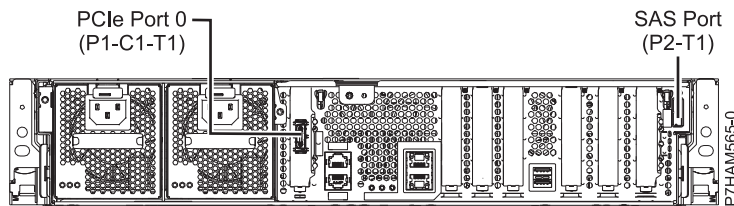

Figure 31. Model 8231-E1C connections for disk drive enclosures and PCIe storage enclosures

Model 8231-E2C connector locations

Learn about connector locations.

The 8231-E2C server provides cable connector locations for the following enclosures:

- Support for expansion units, as shown in the following figure, is as follows:
 - The C1 slot must contain the system power control network (SPCN) card, and the C8 slot must contain the card with two 12X double data rate (DDR) cable ports.

Note: Installing the 12X DDR cable ports at this location causes both the C8 and C6 slot space to be occupied.

- The server cannot support both 12X DDR cable ports and PCIe cable ports at the same time.
- The server contains a serial-attached SCSI (SAS) port.
- Support for disk drive enclosures, as shown in the following figure, is as follows:

- The server contains a SAS port.

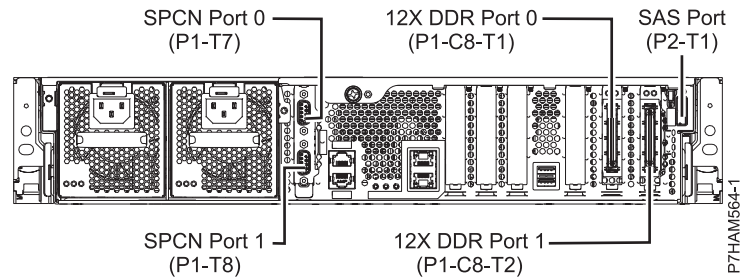

Figure 32. Model 8231-E2C connections for expansion units and disk drive enclosures

- Support for PCIe storage enclosures, as shown in the following figure, is as follows:
 - The card installed in the C1 slot can contain one PCIe cable port, and the card installed in the C8 slot can contain one PCIe cable port.
 - The server cannot support both PCIe cable ports and 12X DDR cable ports at the same time.
 - The server contains a SAS port.

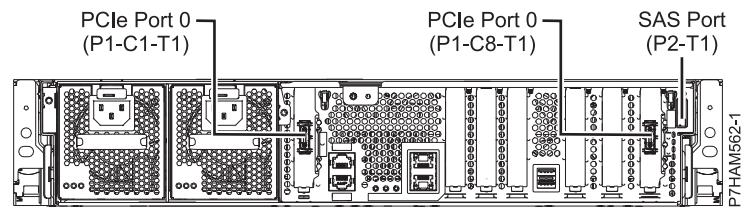

Figure 33. Model 8231-E2C connections for PCIe storage enclosures

Model 8231-E2D connector locations

Learn about connector locations.

The 8231-E2D server provides cable connector locations for the following enclosures:

- Support for expansion units, as shown in the following figure, is as follows:
 - The C1 slot must contain the system power control network (SPCN) card, and the C8 slot must contain the card with two 12X double data rate (DDR) cable ports.

Note: Installing the 12X DDR cable ports at this location causes both the C8 and C6 slot space to be occupied.

- The server cannot support both 12X DDR cable ports and PCIe cable ports at the same time.
- The server contains a serial-attached SCSI (SAS) port.
- Support for disk drive enclosures, as shown in the following figure, is as follows:
 - The server contains a SAS port.

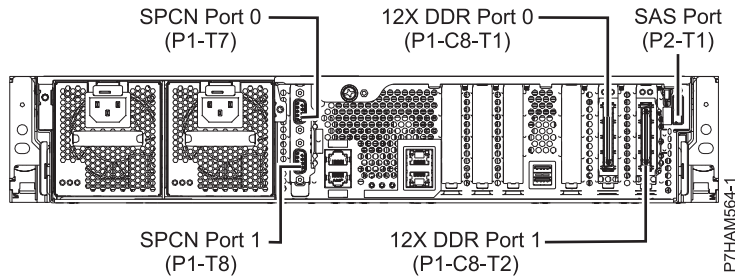

Figure 34. Model 8231-E2D connections for expansion units and disk drive enclosures

- Support for PCIe storage enclosures, as shown in the following figure, is as follows:
 - The card installed in the C1 slot can contain one PCIe cable port, and the card installed in the C8 slot can contain one PCIe cable port.
 - The server cannot support both PCIe cable ports and 12X DDR cable ports at the same time.
 - The server contains a SAS port.

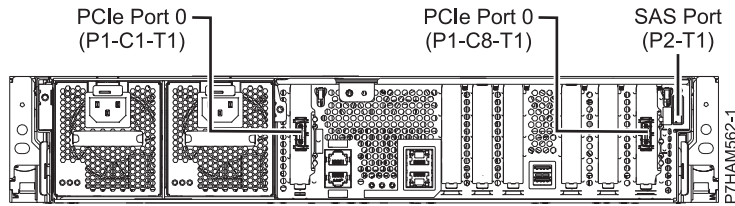

Figure 35. Model 8231-E2D connections for PCIe storage enclosures

Model 8233-E8B connector locations

Learn about connector locations on rack-mounted models.

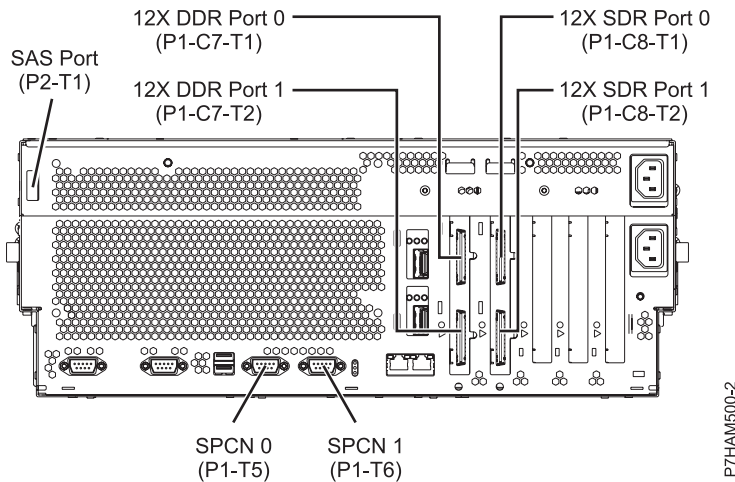

Figure 36. Model 8233-E8B connector locations on a rack-mounted model

Model 8246-L1S connector locations

Learn about connector locations.

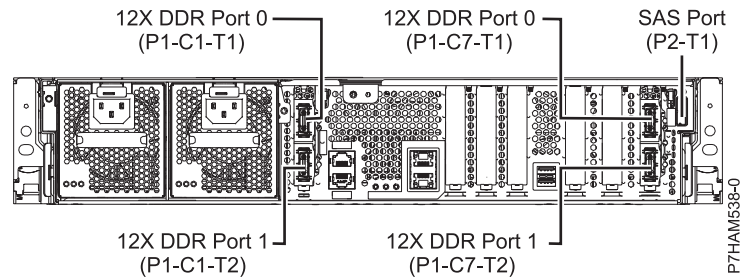

Figure 37. Model 8246-L1S connector locations

Model 8246-L2S connector locations

Learn about connector locations.

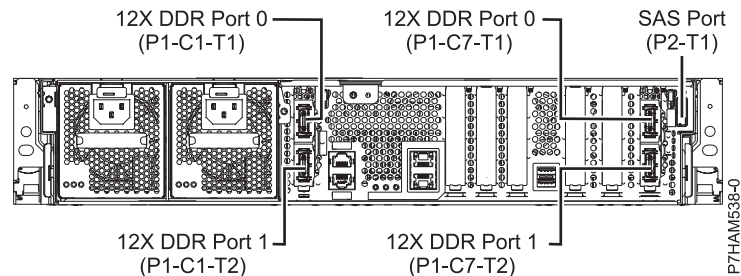

Figure 38. Model 8246-L2S connector locations

Model 8248-L4T, 8408-E8D, or 9109-RMD connector locations

Learn about connector locations.

The 8248-L4T, 8408-E8D, and 9109-RMD servers provide cable connector locations for the following enclosures:

- Support for expansion units, as shown in the following figure, is as follows:
 - The card installed in the C2 slot can contain two 12X double data rate (DDR) cable ports. However, the C2 slot cannot provide both 12X DDR and PCIe cable ports.
 - The card installed in the C3 slot can contain two 12X DDR cable ports. However, the C3 slot cannot provide both 12X DDR and PCIe cable ports.
- Support for disk drive enclosures, as shown in the following figure, is as follows:
 - The server contains a SAS port.
- Support for PCIe storage enclosures, as shown in the following figure, is as follows:
 - The card installed in the C2 slot can contain two PCIe cable ports. However, the C2 slot cannot provide both PCIe and 12X DDR cable ports.
 - The card installed in the C3 slot can contain two PCIe cable ports. However, the C3 slot cannot provide both PCIe and 12X DDR cable ports.

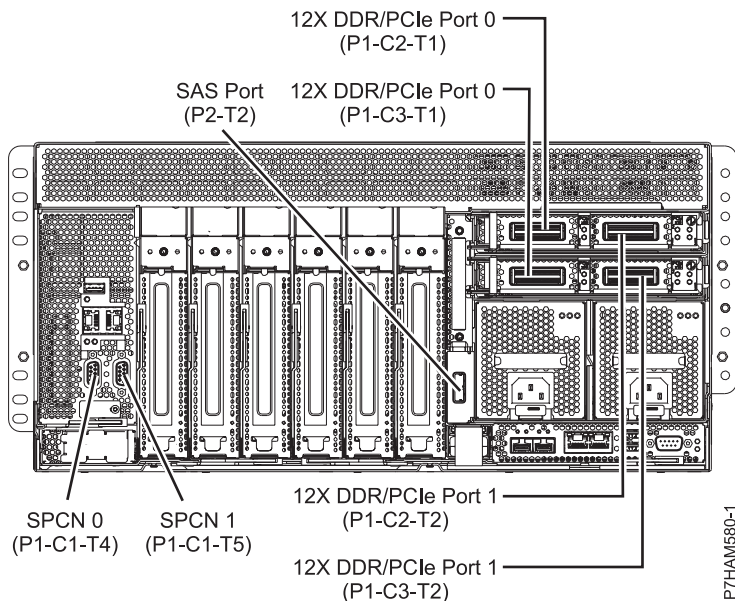

Figure 39. Model 8248-L4T, 8408-E8D, or 9109-RMD connector locations for expansion units, disk drive enclosures, and PCIe storage enclosures

Model 8412-EAD connector locations

Learn about connector locations.

The 8412-EAD server provides cable connector locations for the following enclosures:

- Support for expansion units, as shown in the following figure, is as follows:
 - The card installed in the C2 slot can contain two 12X double data rate (DDR) cable ports. However, the C2 slot cannot provide both 12X DDR and PCIe cable ports.
 - The card installed in the C3 slot can contain two 12X DDR cable ports. However, the C3 slot cannot provide both 12X DDR and PCIe cable ports.
- Support for disk drive enclosures, as shown in the following figure, is as follows:
 - The server contains a SAS port.
- Support for PCIe storage enclosures, as shown in the following figure, is as follows:
 - The card installed in the C2 slot can contain two PCIe cable ports. However, the C2 slot cannot provide both PCIe and 12X DDR cable ports.
 - The card installed in the C3 slot can contain two PCIe cable ports. However, the C3 slot cannot provide both PCIe and 12X DDR cable ports.

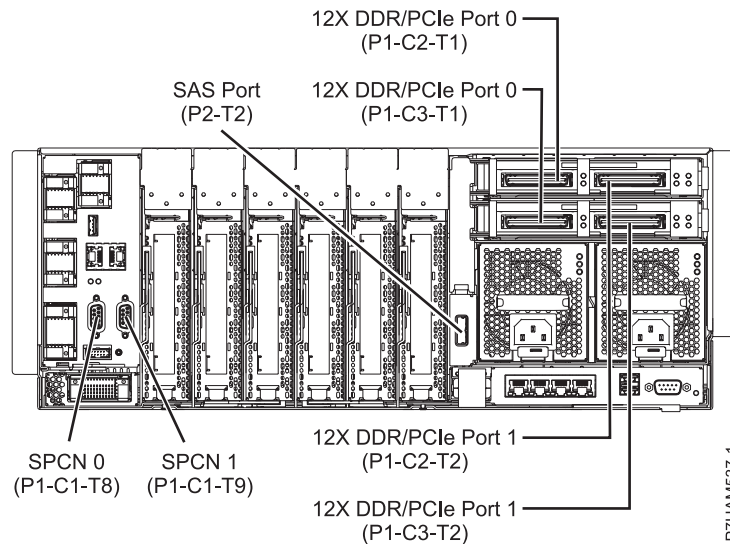

Figure 40. Model 8412-EAD connector locations for expansion units, disk drive enclosures, and PCIe storage enclosures

Model 9117-MMB or 9179-MHB connector locations

Learn about connector locations.

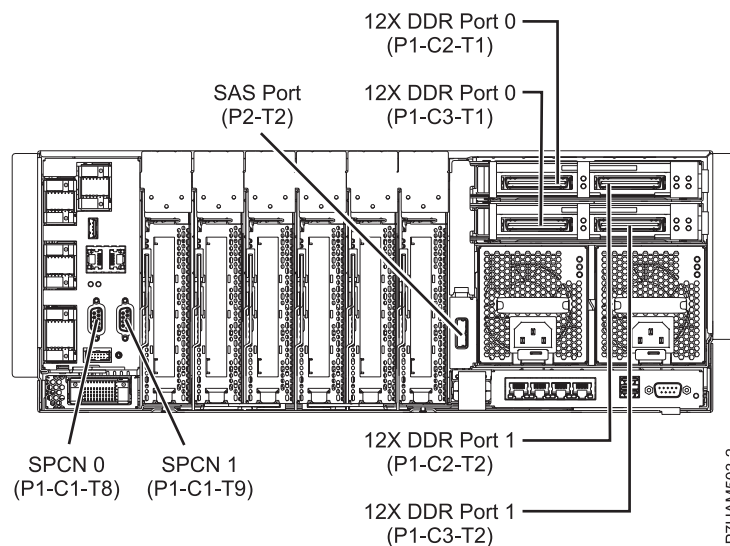

Figure 41. Model 9117-MMB or 9179-MHB connector locations

Model 9117-MMC or 9179-MHC connector locations

Learn about connector locations.

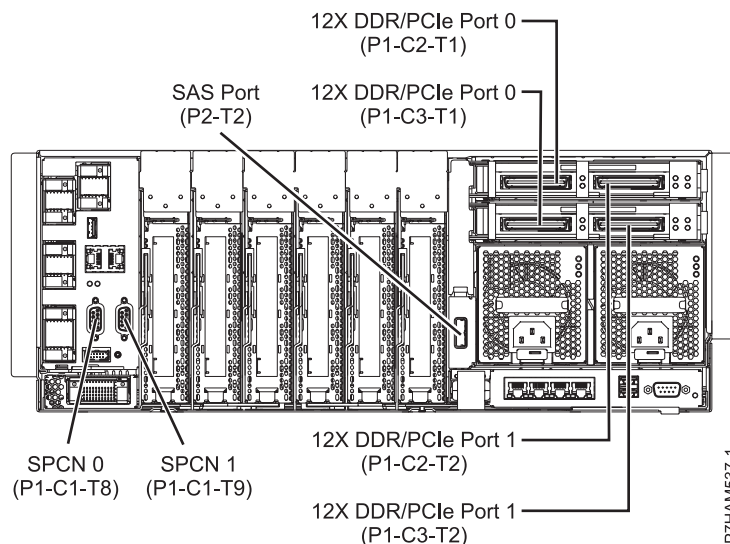

Figure 42. Model 9117-MMC or 9179-MHC connector locations

Model 9117-MMD or 9179-MHD connector locations

Learn about connector locations.

The 9117-MMD and 9179-MHD servers provide cable connector locations for the following enclosures:

- Support for expansion units, as shown in the following figure, is as follows:
 - The card installed in the C2 slot can contain two 12X double data rate (DDR) cable ports. However, the C2 slot cannot provide both 12X DDR and PCIe cable ports.
 - The card installed in the C3 slot can contain two 12X DDR cable ports. However, the C3 slot cannot provide both 12X DDR and PCIe cable ports.
- Support for disk drive enclosures, as shown in the following figure, is as follows:
 - The server contains a SAS port.
- Support for PCIe storage enclosures, as shown in the following figure, is as follows:
 - The card installed in the C2 slot can contain two PCIe cable ports. However, the C2 slot cannot provide both PCIe and 12X DDR cable ports.
 - The card installed in the C3 slot can contain two PCIe cable ports. However, the C3 slot cannot provide both PCIe and 12X DDR cable ports.

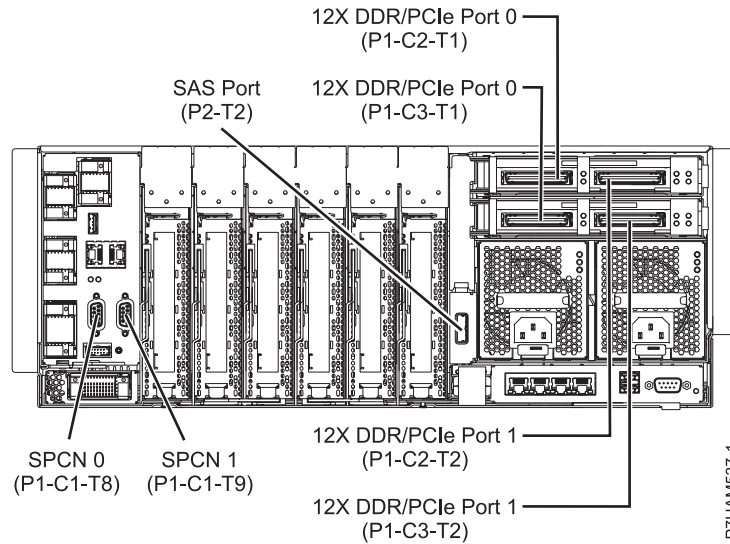

Figure 43. Model 9117-MMD or 9179-MHD connector locations for expansion units, disk drive enclosures, and PCIe storage enclosures

Enclosure connectors

Learn about connector locations for I/O enclosures.

Model 5802 and 5877 connector locations

Learn about connector locations.

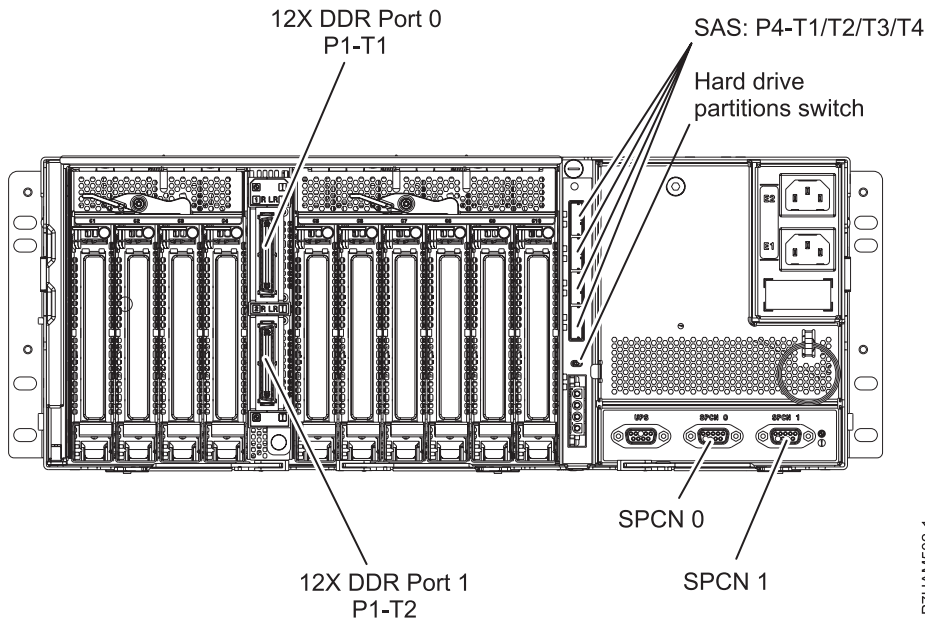

Figure 44. Model 5802 and 5877 connector locations

Notices

This information was developed for products and services offered in the U.S.A.

The manufacturer may not offer the products, services, or features discussed in this document in other countries. Consult the manufacturer's representative for information on the products and services currently available in your area. Any reference to the manufacturer's product, program, or service is not intended to state or imply that only that product, program, or service may be used. Any functionally equivalent product, program, or service that does not infringe any intellectual property right of the manufacturer may be used instead. However, it is the user's responsibility to evaluate and verify the operation of any product, program, or service.

The manufacturer may have patents or pending patent applications covering subject matter described in this document. The furnishing of this document does not grant you any license to these patents. You can send license inquiries, in writing, to the manufacturer.

The following paragraph does not apply to the United Kingdom or any other country where such provisions are inconsistent with local law: THIS PUBLICATION IS PROVIDED "AS IS" WITHOUT WARRANTY OF ANY KIND, EITHER EXPRESS OR IMPLIED, INCLUDING, BUT NOT LIMITED TO, THE IMPLIED WARRANTIES OF NON-INFRINGEMENT, MERCHANTABILITY OR FITNESS FOR A PARTICULAR PURPOSE. Some states do not allow disclaimer of express or implied warranties in certain transactions, therefore, this statement may not apply to you.

This information could include technical inaccuracies or typographical errors. Changes are periodically made to the information herein; these changes will be incorporated in new editions of the publication. The manufacturer may make improvements and/or changes in the product(s) and/or the program(s) described in this publication at any time without notice.

Any references in this information to websites not owned by the manufacturer are provided for convenience only and do not in any manner serve as an endorsement of those websites. The materials at those websites are not part of the materials for this product and use of those websites is at your own risk.

The manufacturer may use or distribute any of the information you supply in any way it believes appropriate without incurring any obligation to you.

Any performance data contained herein was determined in a controlled environment. Therefore, the results obtained in other operating environments may vary significantly. Some measurements may have been made on development-level systems and there is no guarantee that these measurements will be the same on generally available systems. Furthermore, some measurements may have been estimated through extrapolation. Actual results may vary. Users of this document should verify the applicable data for their specific environment.

Information concerning products not produced by this manufacturer was obtained from the suppliers of those products, their published announcements or other publicly available sources. This manufacturer has not tested those products and cannot confirm the accuracy of performance, compatibility or any other claims related to products not produced by this manufacturer. Questions on the capabilities of products not produced by this manufacturer should be addressed to the suppliers of those products.

All statements regarding the manufacturer's future direction or intent are subject to change or withdrawal without notice, and represent goals and objectives only.

The manufacturer's prices shown are the manufacturer's suggested retail prices, are current and are subject to change without notice. Dealer prices may vary.

This information is for planning purposes only. The information herein is subject to change before the products described become available.

This information contains examples of data and reports used in daily business operations. To illustrate them as completely as possible, the examples include the names of individuals, companies, brands, and products. All of these names are fictitious and any similarity to the names and addresses used by an actual business enterprise is entirely coincidental.

If you are viewing this information in softcopy, the photographs and color illustrations may not appear.

The drawings and specifications contained herein shall not be reproduced in whole or in part without the written permission of the manufacturer.

The manufacturer has prepared this information for use with the specific machines indicated. The manufacturer makes no representations that it is suitable for any other purpose.

The manufacturer's computer systems contain mechanisms designed to reduce the possibility of undetected data corruption or loss. This risk, however, cannot be eliminated. Users who experience unplanned outages, system failures, power fluctuations or outages, or component failures must verify the accuracy of operations performed and data saved or transmitted by the system at or near the time of the outage or failure. In addition, users must establish procedures to ensure that there is independent data verification before relying on such data in sensitive or critical operations. Users should periodically check the manufacturer's support websites for updated information and fixes applicable to the system and related software.

Homologation statement

This product may not be certified in your country for connection by any means whatsoever to interfaces of public telecommunications networks. Further certification may be required by law prior to making any such connection. Contact an IBM representative or reseller for any questions.

Trademarks

IBM, the IBM logo, and ibm.com are trademarks or registered trademarks of International Business Machines Corp., registered in many jurisdictions worldwide. Other product and service names might be trademarks of IBM or other companies. A current list of IBM trademarks is available on the web at www.ibm.com/legal/copytrade.shtml.

Linux is a registered trademark of Linus Torvalds in the United States, other countries, or both.

Electronic emission notices

When attaching a monitor to the equipment, you must use the designated monitor cable and any interference suppression devices supplied with the monitor.

Class A Notices

The following Class A statements apply to the IBM servers that contain the POWER7[®] processor and its features unless designated as electromagnetic compatibility (EMC) Class B in the feature information.

Federal Communications Commission (FCC) statement

Note: This equipment has been tested and found to comply with the limits for a Class A digital device, pursuant to Part 15 of the FCC Rules. These limits are designed to provide reasonable protection against harmful interference when the equipment is operated in a commercial environment. This equipment generates, uses, and can radiate radio frequency energy and, if not installed and used in accordance with

the instruction manual, may cause harmful interference to radio communications. Operation of this equipment in a residential area is likely to cause harmful interference, in which case the user will be required to correct the interference at his own expense.

Properly shielded and grounded cables and connectors must be used in order to meet FCC emission limits. IBM is not responsible for any radio or television interference caused by using other than recommended cables and connectors or by unauthorized changes or modifications to this equipment. Unauthorized changes or modifications could void the user's authority to operate the equipment.

This device complies with Part 15 of the FCC rules. Operation is subject to the following two conditions: (1) this device may not cause harmful interference, and (2) this device must accept any interference received, including interference that may cause undesired operation.

Industry Canada Compliance Statement

This Class A digital apparatus complies with Canadian ICES-003.

Avis de conformité à la réglementation d'Industrie Canada

Cet appareil numérique de la classe A est conforme à la norme NMB-003 du Canada.

European Community Compliance Statement

This product is in conformity with the protection requirements of EU Council Directive 2004/108/EC on the approximation of the laws of the Member States relating to electromagnetic compatibility. IBM cannot accept responsibility for any failure to satisfy the protection requirements resulting from a non-recommended modification of the product, including the fitting of non-IBM option cards.

This product has been tested and found to comply with the limits for Class A Information Technology Equipment according to European Standard EN 55022. The limits for Class A equipment were derived for commercial and industrial environments to provide reasonable protection against interference with licensed communication equipment.

European Community contact:
IBM Deutschland GmbH
Technical Regulations, Department M372
IBM-Allee 1, 71139 Ehningen, Germany
Tele: +49 7032 15 2941
email: lugi@de.ibm.com

Warning: This is a Class A product. In a domestic environment, this product may cause radio interference, in which case the user may be required to take adequate measures.

VCCI Statement - Japan

この装置は、クラスA情報技術装置です。この装置を家庭環境で使用すると電波妨害を引き起こすことがあります。この場合には使用者が適切な対策を講ずるよう要求されることがあります。

VCCI-A

The following is a summary of the VCCI Japanese statement in the box above:

This is a Class A product based on the standard of the VCCI Council. If this equipment is used in a domestic environment, radio interference may occur, in which case, the user may be required to take corrective actions.

Japanese Electronics and Information Technology Industries Association (JEITA) Confirmed Harmonics Guideline (products less than or equal to 20 A per phase)

高調波ガイドライン適合品

Japanese Electronics and Information Technology Industries Association (JEITA) Confirmed Harmonics Guideline with Modifications (products greater than 20 A per phase)

高調波ガイドライン準用品

Electromagnetic Interference (EMI) Statement - People's Republic of China

声 明

此为 A 级产品,在生活环境
中,该产品可能会造成无线电干
扰。在这种情况下,可能需要用
户对其干扰采取切实可行的措
施。

Declaration: This is a Class A product. In a domestic environment this product may cause radio interference in which case the user may need to perform practical action.

Electromagnetic Interference (EMI) Statement - Taiwan

警告使用者：

這是甲類的資訊產品，在居住的環境中使用時，可能會造成射頻干擾，在這種情況下，使用者會被要求採取某些適當的對策。

The following is a summary of the EMI Taiwan statement above.

Warning: This is a Class A product. In a domestic environment this product may cause radio interference in which case the user will be required to take adequate measures.

IBM Taiwan Contact Information:

台灣IBM 產品服務聯絡方式：
台灣國際商業機器股份有限公司
台北市松仁路7號3樓
電話：0800-016-888

Electromagnetic Interference (EMI) Statement - Korea

이 기기는 업무용(A급)으로 전자파적합기기로서 판매자 또는 사용자는 이 점을 주의하시기 바라며, 가정외의 지역에서 사용하는 것을 목적으로 합니다.

Germany Compliance Statement

Deutschsprachiger EU Hinweis: Hinweis für Geräte der Klasse A EU-Richtlinie zur Elektromagnetischen Verträglichkeit

Dieses Produkt entspricht den Schutzanforderungen der EU-Richtlinie 2004/108/EG zur Angleichung der Rechtsvorschriften über die elektromagnetische Verträglichkeit in den EU-Mitgliedsstaaten und hält die Grenzwerte der EN 55022 Klasse A ein.

Um dieses sicherzustellen, sind die Geräte wie in den Handbüchern beschrieben zu installieren und zu betreiben. Des Weiteren dürfen auch nur von der IBM empfohlene Kabel angeschlossen werden. IBM übernimmt keine Verantwortung für die Einhaltung der Schutzanforderungen, wenn das Produkt ohne Zustimmung von IBM verändert bzw. wenn Erweiterungskomponenten von Fremdherstellern ohne Empfehlung von IBM gesteckt/eingebaut werden.

EN 55022 Klasse A Geräte müssen mit folgendem Warnhinweis versehen werden:

"Warnung: Dieses ist eine Einrichtung der Klasse A. Diese Einrichtung kann im Wohnbereich Funk-Störungen verursachen; in diesem Fall kann vom Betreiber verlangt werden, angemessene Maßnahmen zu ergreifen und dafür aufzukommen."

Deutschland: Einhaltung des Gesetzes über die elektromagnetische Verträglichkeit von Geräten

Dieses Produkt entspricht dem "Gesetz über die elektromagnetische Verträglichkeit von Geräten (EMVG)". Dies ist die Umsetzung der EU-Richtlinie 2004/108/EG in der Bundesrepublik Deutschland.

Zulassungsbescheinigung laut dem Deutschen Gesetz über die elektromagnetische Verträglichkeit von Geräten (EMVG) (bzw. der EMC EG Richtlinie 2004/108/EG) für Geräte der Klasse A

Dieses Gerät ist berechtigt, in Übereinstimmung mit dem Deutschen EMVG das EG-Konformitätszeichen - CE - zu führen.

Verantwortlich für die Einhaltung der EMV Vorschriften ist der Hersteller:
International Business Machines Corp.
New Orchard Road
Armonk, New York 10504
Tel: 914-499-1900

Der verantwortliche Ansprechpartner des Herstellers in der EU ist:
IBM Deutschland GmbH
Technical Regulations, Abteilung M372
IBM-Allee 1, 71139 Ehningen, Germany
Tel: +49 7032 15 2941
email: lugi@de.ibm.com

Generelle Informationen:

Das Gerät erfüllt die Schutzanforderungen nach EN 55024 und EN 55022 Klasse A.

Electromagnetic Interference (EMI) Statement - Russia

ВНИМАНИЕ! Настоящее изделие относится к классу А.
В жилых помещениях оно может создавать
радиопомехи, для снижения которых необходимы
дополнительные меры

Class B Notices

The following Class B statements apply to features designated as electromagnetic compatibility (EMC) Class B in the feature installation information.

Federal Communications Commission (FCC) statement

This equipment has been tested and found to comply with the limits for a Class B digital device, pursuant to Part 15 of the FCC Rules. These limits are designed to provide reasonable protection against harmful interference in a residential installation.

This equipment generates, uses, and can radiate radio frequency energy and, if not installed and used in accordance with the instructions, may cause harmful interference to radio communications. However, there is no guarantee that interference will not occur in a particular installation.

If this equipment does cause harmful interference to radio or television reception, which can be determined by turning the equipment off and on, the user is encouraged to try to correct the interference by one or more of the following measures:

- Reorient or relocate the receiving antenna.
- Increase the separation between the equipment and receiver.
- Connect the equipment into an outlet on a circuit different from that to which the receiver is connected.
- Consult an IBM-authorized dealer or service representative for help.

Properly shielded and grounded cables and connectors must be used in order to meet FCC emission limits. Proper cables and connectors are available from IBM-authorized dealers. IBM is not responsible for

any radio or television interference caused by unauthorized changes or modifications to this equipment. Unauthorized changes or modifications could void the user's authority to operate this equipment.

This device complies with Part 15 of the FCC rules. Operation is subject to the following two conditions: (1) this device may not cause harmful interference, and (2) this device must accept any interference received, including interference that may cause undesired operation.

Industry Canada Compliance Statement

This Class B digital apparatus complies with Canadian ICES-003.

Avis de conformité à la réglementation d'Industrie Canada

Cet appareil numérique de la classe B est conforme à la norme NMB-003 du Canada.

European Community Compliance Statement

This product is in conformity with the protection requirements of EU Council Directive 2004/108/EC on the approximation of the laws of the Member States relating to electromagnetic compatibility. IBM cannot accept responsibility for any failure to satisfy the protection requirements resulting from a non-recommended modification of the product, including the fitting of non-IBM option cards.

This product has been tested and found to comply with the limits for Class B Information Technology Equipment according to European Standard EN 55022. The limits for Class B equipment were derived for typical residential environments to provide reasonable protection against interference with licensed communication equipment.

European Community contact:
IBM Deutschland GmbH
Technical Regulations, Department M372
IBM-Allee 1, 71139 Ehningen, Germany
Tele: +49 7032 15 2941
email: lugi@de.ibm.com

VCCI Statement - Japan

この装置は、クラスB情報技術装置です。この装置は、家庭環境で使用することを目的としていますが、この装置がラジオやテレビジョン受信機に近接して使用されると、受信障害を引き起こすことがあります。

取扱説明書に従って正しい取り扱いをして下さい。 VCCI-B

Japanese Electronics and Information Technology Industries Association (JEITA) Confirmed Harmonics Guideline (products less than or equal to 20 A per phase)

高調波ガイドライン適合品

**Japanese Electronics and Information Technology Industries Association (JEITA)
Confirmed Harmonics Guideline with Modifications (products greater than 20 A per
phase)**

高調波ガイドライン準用品

IBM Taiwan Contact Information

台灣IBM 產品服務聯絡方式：
台灣國際商業機器股份有限公司
台北市松仁路7號3樓
電話：0800-016-888

Electromagnetic Interference (EMI) Statement - Korea

이 기기는 가정용(B급)으로 전자파적합기기로서 주로 가정에서 사용하는 것을 목적으로 하며, 모든 지역에서 사용할 수 있습니다.

Germany Compliance Statement

**Deutschsprachiger EU Hinweis: Hinweis für Geräte der Klasse B EU-Richtlinie zur
Elektromagnetischen Verträglichkeit**

Dieses Produkt entspricht den Schutzanforderungen der EU-Richtlinie 2004/108/EG zur Angleichung der Rechtsvorschriften über die elektromagnetische Verträglichkeit in den EU-Mitgliedsstaaten und hält die Grenzwerte der EN 55022 Klasse B ein.

Um dieses sicherzustellen, sind die Geräte wie in den Handbüchern beschrieben zu installieren und zu betreiben. Des Weiteren dürfen auch nur von der IBM empfohlene Kabel angeschlossen werden. IBM übernimmt keine Verantwortung für die Einhaltung der Schutzanforderungen, wenn das Produkt ohne Zustimmung von IBM verändert bzw. wenn Erweiterungskomponenten von Fremdherstellern ohne Empfehlung von IBM gesteckt/eingebaut werden.

Deutschland: Einhaltung des Gesetzes über die elektromagnetische Verträglichkeit von Geräten

Dieses Produkt entspricht dem "Gesetz über die elektromagnetische Verträglichkeit von Geräten (EMVG)". Dies ist die Umsetzung der EU-Richtlinie 2004/108/EG in der Bundesrepublik Deutschland.

**Zulassungsbescheinigung laut dem Deutschen Gesetz über die elektromagnetische Verträglichkeit von
Geräten (EMVG) (bzw. der EMC EG Richtlinie 2004/108/EG) für Geräte der Klasse B**

Dieses Gerät ist berechtigt, in Übereinstimmung mit dem Deutschen EMVG das EG-Konformitätszeichen - CE - zu führen.

Verantwortlich für die Einhaltung der EMV Vorschriften ist der Hersteller:
International Business Machines Corp.
New Orchard Road
Armonk, New York 10504
Tel: 914-499-1900

Der verantwortliche Ansprechpartner des Herstellers in der EU ist:
IBM Deutschland GmbH
Technical Regulations, Abteilung M372
IBM-Allee 1, 71139 Ehningen, Germany
Tel: +49 7032 15 2941
email: lugi@de.ibm.com

Generelle Informationen:

Das Gerät erfüllt die Schutzanforderungen nach EN 55024 und EN 55022 Klasse B.

Terms and conditions

Permissions for the use of these publications are granted subject to the following terms and conditions.

Applicability: These terms and conditions are in addition to any terms of use for the IBM website.

Personal Use: You may reproduce these publications for your personal, noncommercial use provided that all proprietary notices are preserved. You may not distribute, display or make derivative works of these publications, or any portion thereof, without the express consent of IBM.

Commercial Use: You may reproduce, distribute and display these publications solely within your enterprise provided that all proprietary notices are preserved. You may not make derivative works of these publications, or reproduce, distribute or display these publications or any portion thereof outside your enterprise, without the express consent of IBM.

Rights: Except as expressly granted in this permission, no other permissions, licenses or rights are granted, either express or implied, to the Publications or any information, data, software or other intellectual property contained therein.

IBM reserves the right to withdraw the permissions granted herein whenever, in its discretion, the use of the publications is detrimental to its interest or, as determined by IBM, the above instructions are not being properly followed.

You may not download, export or re-export this information except in full compliance with all applicable laws and regulations, including all United States export laws and regulations.

IBM MAKES NO GUARANTEE ABOUT THE CONTENT OF THESE PUBLICATIONS. THE PUBLICATIONS ARE PROVIDED "AS-IS" AND WITHOUT WARRANTY OF ANY KIND, EITHER EXPRESSED OR IMPLIED, INCLUDING BUT NOT LIMITED TO IMPLIED WARRANTIES OF MERCHANTABILITY, NON-INFRINGEMENT, AND FITNESS FOR A PARTICULAR PURPOSE.



Part Number: 00L5079

Printed in USA

GI11-4307-09



(1P) P/N: 00L5079

