

Power Systems

*Installing the 5886
disk drive enclosure*



Power Systems

*Installing the 5886
disk drive enclosure*



Note

Before using this information and the product it supports, read the information in “Safety notices” on page v, “Notices” on page 27, the *IBM Systems Safety Notices* manual, G229-9054, and the *IBM Environmental Notices and User Guide*, Z125-5823.

This edition applies to IBM Power Systems™ servers that contain the POWER7 processor and to all associated models.

This edition replaces GI11-2910-07.

© **Copyright IBM Corporation 2010, 2013.**

US Government Users Restricted Rights – Use, duplication or disclosure restricted by GSA ADP Schedule Contract with IBM Corp.

Contents

| | |
|---|-----------|
| Safety notices | v |
| Installing the 5886 disk drive enclosure | 1 |
| Installing the 5886 disk drive enclosure: Details | 3 |
| Reference information | 15 |
| Connector locations | 15 |
| Server connectors | 15 |
| Model 8202-E4B connector locations | 15 |
| Model 8202-E4C connector locations | 16 |
| Model 8202-E4D connector locations | 17 |
| Model 8205-E6B connector locations | 18 |
| Model 8205-E6C connector locations | 18 |
| Model 8205-E6D connector locations | 19 |
| Model 8231-E1C connector locations | 20 |
| Model 8231-E2B connector locations | 20 |
| Model 8231-E2C connector locations | 21 |
| Model 8233-E8B connector locations | 22 |
| Model 8248-L4T, 8408-E8D, or 9109-RMD connector locations | 22 |
| Model 8412-EAD connector locations | 23 |
| Model 9117-MMB or 9179-MHB connector locations | 24 |
| Model 9117-MMC or 9179-MHC connector locations | 25 |
| Model 9117-MMD or 9179-MHD connector locations | 25 |
| Enclosure connectors | 26 |
| Model 5886 connector locations | 26 |
| Notices | 27 |
| Trademarks | 28 |
| Electronic emission notices | 28 |
| Class A Notices | 28 |
| Class B Notices | 32 |
| Terms and conditions | 35 |

Safety notices

Safety notices may be printed throughout this guide:

- **DANGER** notices call attention to a situation that is potentially lethal or extremely hazardous to people.
- **CAUTION** notices call attention to a situation that is potentially hazardous to people because of some existing condition.
- **Attention** notices call attention to the possibility of damage to a program, device, system, or data.

World Trade safety information

Several countries require the safety information contained in product publications to be presented in their national languages. If this requirement applies to your country, safety information documentation is included in the publications package (such as in printed documentation, on DVD, or as part of the product) shipped with the product. The documentation contains the safety information in your national language with references to the U.S. English source. Before using a U.S. English publication to install, operate, or service this product, you must first become familiar with the related safety information documentation. You should also refer to the safety information documentation any time you do not clearly understand any safety information in the U.S. English publications.

Replacement or additional copies of safety information documentation can be obtained by calling the IBM Hotline at 1-800-300-8751.

German safety information

Das Produkt ist nicht für den Einsatz an Bildschirmarbeitsplätzen im Sinne § 2 der Bildschirmarbeitsverordnung geeignet.

Laser safety information

IBM® servers can use I/O cards or features that are fiber-optic based and that utilize lasers or LEDs.

Laser compliance

IBM servers may be installed inside or outside of an IT equipment rack.

DANGER

When working on or around the system, observe the following precautions:

Electrical voltage and current from power, telephone, and communication cables are hazardous. To avoid a shock hazard:

- Connect power to this unit only with the IBM provided power cord. Do not use the IBM provided power cord for any other product.
- Do not open or service any power supply assembly.
- Do not connect or disconnect any cables or perform installation, maintenance, or reconfiguration of this product during an electrical storm.
- The product might be equipped with multiple power cords. To remove all hazardous voltages, disconnect all power cords.
- Connect all power cords to a properly wired and grounded electrical outlet. Ensure that the outlet supplies proper voltage and phase rotation according to the system rating plate.
- Connect any equipment that will be attached to this product to properly wired outlets.
- When possible, use one hand only to connect or disconnect signal cables.
- Never turn on any equipment when there is evidence of fire, water, or structural damage.
- Disconnect the attached power cords, telecommunications systems, networks, and modems before you open the device covers, unless instructed otherwise in the installation and configuration procedures.
- Connect and disconnect cables as described in the following procedures when installing, moving, or opening covers on this product or attached devices.

To Disconnect:

1. Turn off everything (unless instructed otherwise).
2. Remove the power cords from the outlets.
3. Remove the signal cables from the connectors.
4. Remove all cables from the devices.

To Connect:

1. Turn off everything (unless instructed otherwise).
2. Attach all cables to the devices.
3. Attach the signal cables to the connectors.
4. Attach the power cords to the outlets.
5. Turn on the devices.

(D005)

DANGER

Observe the following precautions when working on or around your IT rack system:

- Heavy equipment—personal injury or equipment damage might result if mishandled.
- Always lower the leveling pads on the rack cabinet.
- Always install stabilizer brackets on the rack cabinet.
- To avoid hazardous conditions due to uneven mechanical loading, always install the heaviest devices in the bottom of the rack cabinet. Always install servers and optional devices starting from the bottom of the rack cabinet.
- Rack-mounted devices are not to be used as shelves or work spaces. Do not place objects on top of rack-mounted devices.



- Each rack cabinet might have more than one power cord. Be sure to disconnect all power cords in the rack cabinet when directed to disconnect power during servicing.
- Connect all devices installed in a rack cabinet to power devices installed in the same rack cabinet. Do not plug a power cord from a device installed in one rack cabinet into a power device installed in a different rack cabinet.
- An electrical outlet that is not correctly wired could place hazardous voltage on the metal parts of the system or the devices that attach to the system. It is the responsibility of the customer to ensure that the outlet is correctly wired and grounded to prevent an electrical shock.

CAUTION

- Do not install a unit in a rack where the internal rack ambient temperatures will exceed the manufacturer's recommended ambient temperature for all your rack-mounted devices.
- Do not install a unit in a rack where the air flow is compromised. Ensure that air flow is not blocked or reduced on any side, front, or back of a unit used for air flow through the unit.
- Consideration should be given to the connection of the equipment to the supply circuit so that overloading of the circuits does not compromise the supply wiring or overcurrent protection. To provide the correct power connection to a rack, refer to the rating labels located on the equipment in the rack to determine the total power requirement of the supply circuit.
- *(For sliding drawers.)* Do not pull out or install any drawer or feature if the rack stabilizer brackets are not attached to the rack. Do not pull out more than one drawer at a time. The rack might become unstable if you pull out more than one drawer at a time.
- *(For fixed drawers.)* This drawer is a fixed drawer and must not be moved for servicing unless specified by the manufacturer. Attempting to move the drawer partially or completely out of the rack might cause the rack to become unstable or cause the drawer to fall out of the rack.

(R001)

CAUTION:

Removing components from the upper positions in the rack cabinet improves rack stability during relocation. Follow these general guidelines whenever you relocate a populated rack cabinet within a room or building:

- Reduce the weight of the rack cabinet by removing equipment starting at the top of the rack cabinet. When possible, restore the rack cabinet to the configuration of the rack cabinet as you received it. If this configuration is not known, you must observe the following precautions:
 - Remove all devices in the 32U position and above.
 - Ensure that the heaviest devices are installed in the bottom of the rack cabinet.
 - Ensure that there are no empty U-levels between devices installed in the rack cabinet below the 32U level.
- If the rack cabinet you are relocating is part of a suite of rack cabinets, detach the rack cabinet from the suite.
- Inspect the route that you plan to take to eliminate potential hazards.
- Verify that the route that you choose can support the weight of the loaded rack cabinet. Refer to the documentation that comes with your rack cabinet for the weight of a loaded rack cabinet.
- Verify that all door openings are at least 760 x 230 mm (30 x 80 in.).
- Ensure that all devices, shelves, drawers, doors, and cables are secure.
- Ensure that the four leveling pads are raised to their highest position.
- Ensure that there is no stabilizer bracket installed on the rack cabinet during movement.
- Do not use a ramp inclined at more than 10 degrees.
- When the rack cabinet is in the new location, complete the following steps:
 - Lower the four leveling pads.
 - Install stabilizer brackets on the rack cabinet.
 - If you removed any devices from the rack cabinet, repopulate the rack cabinet from the lowest position to the highest position.
- If a long-distance relocation is required, restore the rack cabinet to the configuration of the rack cabinet as you received it. Pack the rack cabinet in the original packaging material, or equivalent. Also lower the leveling pads to raise the casters off of the pallet and bolt the rack cabinet to the pallet.

(R002)

(L001)



(L002)



(L003)



or



All lasers are certified in the U.S. to conform to the requirements of DHHS 21 CFR Subchapter J for class 1 laser products. Outside the U.S., they are certified to be in compliance with IEC 60825 as a class 1 laser product. Consult the label on each part for laser certification numbers and approval information.

CAUTION:

This product might contain one or more of the following devices: CD-ROM drive, DVD-ROM drive, DVD-RAM drive, or laser module, which are Class 1 laser products. Note the following information:

- Do not remove the covers. Removing the covers of the laser product could result in exposure to hazardous laser radiation. There are no serviceable parts inside the device.
- Use of the controls or adjustments or performance of procedures other than those specified herein might result in hazardous radiation exposure.

(C026)

CAUTION:

Data processing environments can contain equipment transmitting on system links with laser modules that operate at greater than Class 1 power levels. For this reason, never look into the end of an optical fiber cable or open receptacle. (C027)

CAUTION:

This product contains a Class 1M laser. Do not view directly with optical instruments. (C028)

CAUTION:

Some laser products contain an embedded Class 3A or Class 3B laser diode. Note the following information: laser radiation when open. Do not stare into the beam, do not view directly with optical instruments, and avoid direct exposure to the beam. (C030)

CAUTION:

The battery contains lithium. To avoid possible explosion, do not burn or charge the battery.

Do Not:

- ___ Throw or immerse into water
- ___ Heat to more than 100°C (212°F)
- ___ Repair or disassemble

Exchange only with the IBM-approved part. Recycle or discard the battery as instructed by local regulations. In the United States, IBM has a process for the collection of this battery. For information, call 1-800-426-4333. Have the IBM part number for the battery unit available when you call. (C003)

Power and cabling information for NEBS (Network Equipment-Building System) GR-1089-CORE

The following comments apply to the IBM servers that have been designated as conforming to NEBS (Network Equipment-Building System) GR-1089-CORE:

The equipment is suitable for installation in the following:

- Network telecommunications facilities
- Locations where the NEC (National Electrical Code) applies

The intrabuilding ports of this equipment are suitable for connection to intrabuilding or unexposed wiring or cabling only. The intrabuilding ports of this equipment *must not* be metallically connected to the interfaces that connect to the OSP (outside plant) or its wiring. These interfaces are designed for use as intrabuilding interfaces only (Type 2 or Type 4 ports as described in GR-1089-CORE) and require isolation from the exposed OSP cabling. The addition of primary protectors is not sufficient protection to connect these interfaces metallically to OSP wiring.

Note: All Ethernet cables must be shielded and grounded at both ends.

The ac-powered system does not require the use of an external surge protection device (SPD).

The dc-powered system employs an isolated DC return (DC-I) design. The DC battery return terminal *shall not* be connected to the chassis or frame ground.

Installing the 5886 disk drive enclosure

Use this overview as a guide to the tasks required for installing the 5886 disk drive enclosure (EXP12S Expansion Drawer) into a rack and cabling it to a server.

You can use the following table to read about and complete the high-level tasks for installing the 5886 disk drive enclosure.

Table 1. Tasks to install the disk drive enclosure into a rack

| Task | Where to find associated information |
|--|--|
| Perform inventory. Ensure that you have the rails. Ensure that you have both a Philips-head and flat-head screwdriver. | Locate the inventory list for your disk drive enclosure, and verify that you received all of the parts that you ordered. Each order contains, at a minimum, the following items: <ul style="list-style-type: none">• Left and right rack-mounting rails• Mounting screws• Power supply cables If your shipment contains parts that are not required to complete the installation procedure, store those parts until they are required to be used. If you have incorrect, missing, or damaged parts, consult any of the following resources: <ul style="list-style-type: none">• Your IBM reseller.• IBM Rochester manufacturing automated information at 1-800-300-8751 (United States only).• Directory of worldwide contacts at http://www.ibm.com/planetwide. (Select your location to view the service and support contact information.) You can also obtain order information from your marketing representative or IBM Business Partner. |
| Verify that you have a rack. | You must have a rack installed. If you do not have a rack installed, see <i>Installing the rack</i> (http://publib.boulder.ibm.com/infocenter/systems/scope/hw/topic/p7hbf/installrack.htm). |
| Prepare to install the disk drive enclosure. | To ensure that you have taken all other preparatory steps to install this disk drive enclosure, see <i>Installing the 5886 in a rack</i> (http://publib.boulder.ibm.com/infocenter/systems/scope/hw/topic/p7ham/p7ham_5886_prepare.htm). |
| Power off the system, if required, to install the disk drive enclosure. | For requirements and procedures related to shutting down and powering off the system, see <i>Overview for I/O expansion units</i> (http://publib.boulder.ibm.com/infocenter/systems/scope/hw/topic/p7ham/p7ham_expunit_concepts.htm). |
| Determine where to install the disk drive enclosure in the rack. | For suggestions about how to organize the hardware in your rack and to assign a location for the disk drive enclosure, see step 2 on page 3. |

Table 1. Tasks to install the disk drive enclosure into a rack (continued)

| Task | Where to find associated information |
|--|---|
| Mark the location on the rack where the disk drive enclosure will be installed. | To mark the rack location where you will install the disk drive enclosure, see step 2d on page 4. |
| Install the rail assembly in the rack. | To install the mounting hardware in the rack, see step 3 on page 5. |
| Install the disk drive enclosure on the rail assembly. | To install the disk drive enclosure on the rail assembly, see step 4 on page 6. |
| If you have disk drive units that require installation to the disk drive enclosure, install them now. | To install disk drive units to the disk drive enclosure, see step 5 on page 8. |
| Review information about the drive units of the disk drive enclosure, and cable the enclosure to the server. | <p>To learn about the drive units of the disk drive enclosure, see step 6 on page 9.</p> <p>To connect the disk drive enclosure to the server, see step 8 on page 10.</p> |
| Apply power to the hardware. | <p>Connect power cables, and apply power to the disk drive enclosure.</p> <p>If you powered down either the server or the partition before connecting the disk drive enclosure cables to it, apply power to it.</p> |

Installing the 5886 disk drive enclosure: Details

The detailed installation procedure includes information from online references that are specified in the overview. You can use the expanded instructions in this procedure to install your disk drive enclosure into a rack and to cable it to a server.

- This information is provided in printed form as a list of basic tasks for installing the 5886 disk drive enclosure. For the most current version, use the online information: Installing the 5886 disk drive enclosure (<http://publib.boulder.ibm.com/infocenter/systems/scope/hw/topic/p7ecj/p7ecj.pdf>).
- This procedure assumes that you are installing the 5886 disk drive enclosure into an existing rack. If the rack is not yet installed, you must first complete the procedure for Installing the rack (<http://publib.boulder.ibm.com/infocenter/systems/scope/hw/topic/p7hbf/installrack.htm>).
- Before installing the disk drive enclosure into a rack, read the Rack safety notices (<http://publib.boulder.ibm.com/infocenter/systems/scope/hw/topic/p7hbf/racksafety.htm>).

To install the 5886 disk drive enclosure, complete the following tasks:

1. Unpack the disk drive enclosure as follows:
 - a. Refer to the kitting list provided with the rack installation kit, and complete a parts inventory.
 - b. Locate the rack-mounting hardware kit and the system rail assemblies that were included with your disk drive enclosure.

The rails are front-to-back and left-to-right side dependent.

2. Determine where to install the disk drive enclosure into the rack as follows:
 - a. Determine where in the rack to place the disk drive enclosure in relation to other system hardware. As you plan, keep the following steps in mind:
 - 1) Organize larger and heavier units into the lower part of the rack.
 - 2) Plan to install units into the lower part of the rack first.
 - 3) Record the EIA locations in your plan.

Note: The disk drive enclosure is two Electronic Industries Alliance (EIA) units high. An EIA unit is 44.50 mm (1.75 in.) in height. The rack contains three mounting holes for each EIA unit of height. This enclosure, therefore, is 89 mm (3.5 in.) high and covers 6 mounting holes in the rack.

- b. If necessary, remove the filler panels to allow access to the inside of the rack enclosure where you plan to place the disk drive enclosure.

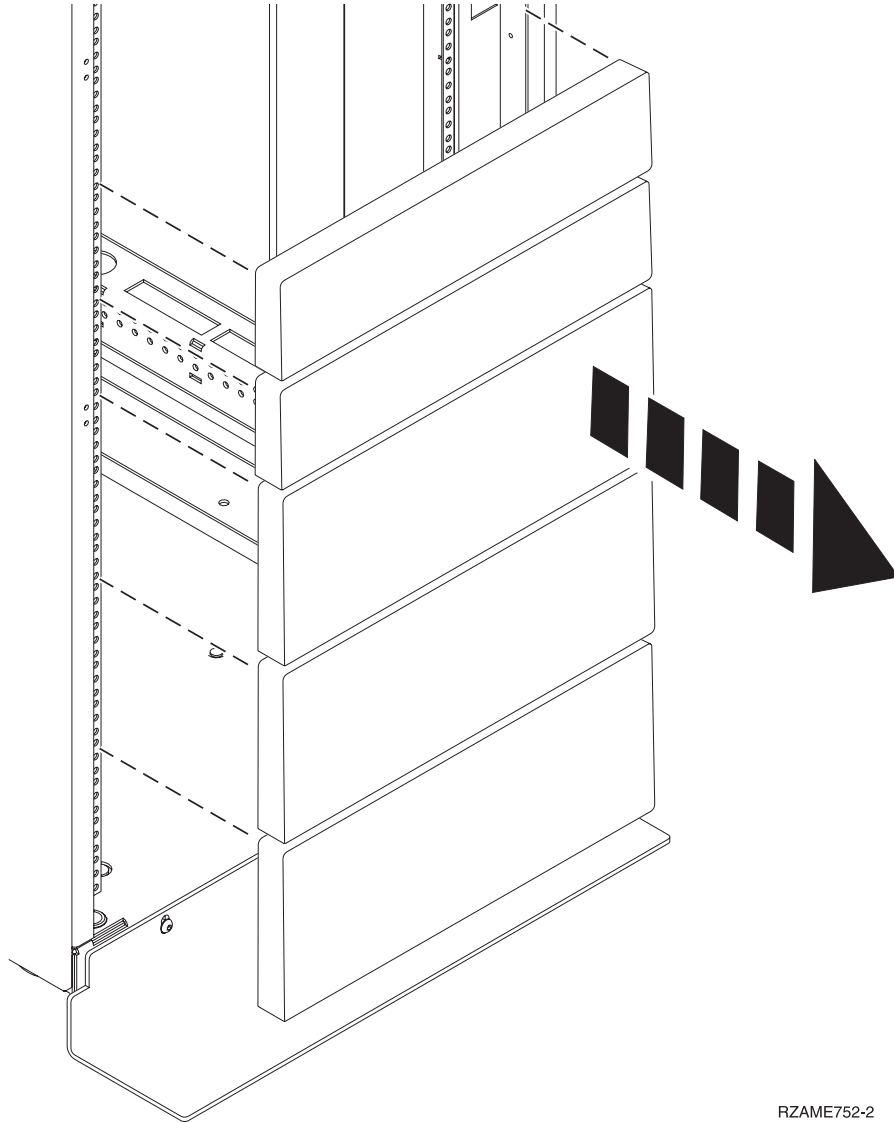

RZAME752-2

Figure 1. Removing the filler panels

- c. If necessary, remove the front and back rack doors.
- d. Mark the rack location where you will install the disk drive enclosure by completing the following steps:
 - 1) Face the front of the rack and work from the left side. Make a note of the lowest EIA unit to be used for the disk drive enclosure. Use tape, a marker, or a pencil to mark the middle mounting hole **(A)** of the lowest EIA unit. Count up two holes and place another mark beside that mounting hole **(B)**. Mark the rack so that these marks can also be seen from the rear of the rack.

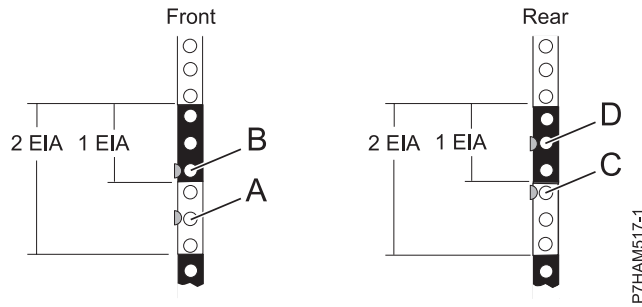

Figure 2. Marking the installation locations

- 2) Repeat the last step to place two marks on the corresponding mounting holes on the front-right side of the rack.
 - 3) Go to the back of the rack. On the left side, find the EIA unit that corresponds to the lowest EIA unit marked on the front of the rack.
 - 4) Mark the top mounting hole (C) of this EIA unit. Count up two holes and place another mark beside that mounting hole (D).
 - 5) Repeat the last step to place two marks on the corresponding mounting holes on the rear-right side of the rack.
3. Install the rail assembly into the rack as follows:

Important: To complete this procedure, use two people to attach the rail assembly to the rack. Position one person in front of the rack and one person at the back of the rack.

CAUTION:

Installing the rails in the rack is a complex procedure. To install the rails correctly, you must perform each task in the following order. Failure to do so might cause rail failure and potential danger to yourself and the system unit.

- a. Loosen the two rail-adjustment screws on one rail just enough to enable the rails to slide.

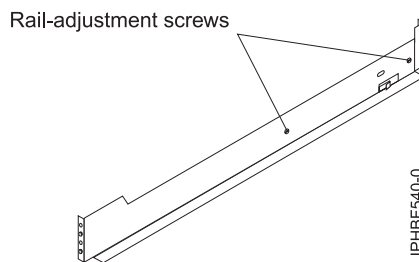

Figure 3. Extending the rails

- b. Locate the marks previously made on the Electronic Industries Alliance (EIA) strips at the front and back of the rack cabinet. Use the **L** or **R** imprinted on the front bracket of your first rail to align it with these marks within the matching side of the rack cabinet. The bottom of the rail support ledge should be slightly above the U mark on the rack flange.

The rail comes with two spacers in the front bracket and two spacers in the rear bracket. If the rack has round holes, the spacers on the rail brackets fit into the round holes in the rack flanges. If the rack has square holes, replace the set of small spacers on the front and rear of the rail with the larger spacers that are included with the rail kit.

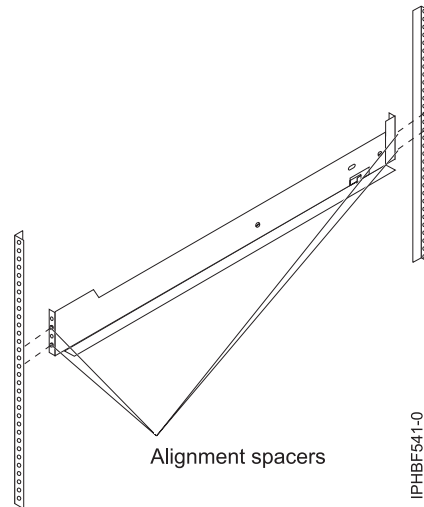

Figure 4. Setting the spacers in place

- c. Secure the rail to the front of the rack cabinet with one M5 screw in the top hole of the bracket. For racks with square holes, add one washer between the M5 screw and the rail bracket.

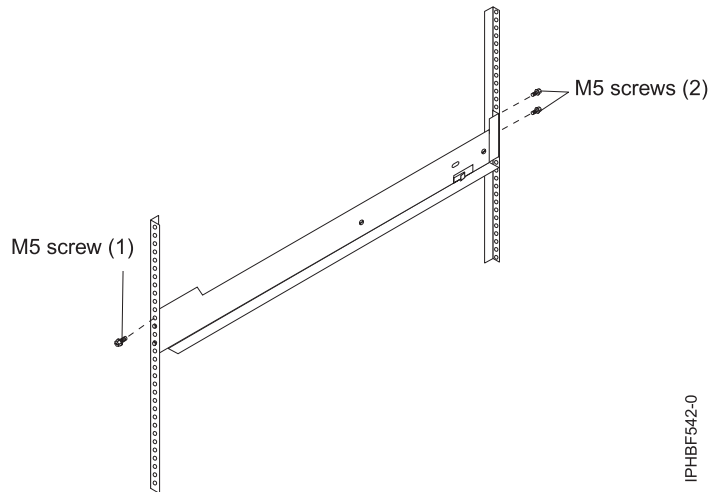

Figure 5. Attaching the rails

- d. Secure the rail to the rear of the rack cabinet with two M5 screws in the top and bottom holes in the rear rail bracket. For racks with square holes, add one washer between each M5 screw and the rail bracket.
 - e. Tighten the rail-adjustment screws.
 - f. Repeat step 3a on page 5 through step 3e for the other rail.
4. Install the disk drive enclosure onto the rails as follows:
 - a. Using two people, lift the disk drive enclosure and position it over the front of the rails.

Attention: Two people are required to safely lift the disk drive enclosure. Using fewer than two people to lift the disk drive enclosure can result in injury.
 - b. Slide the disk drive enclosure into the rack cabinet, making sure that it slides into the tabs on the rear of the rail.

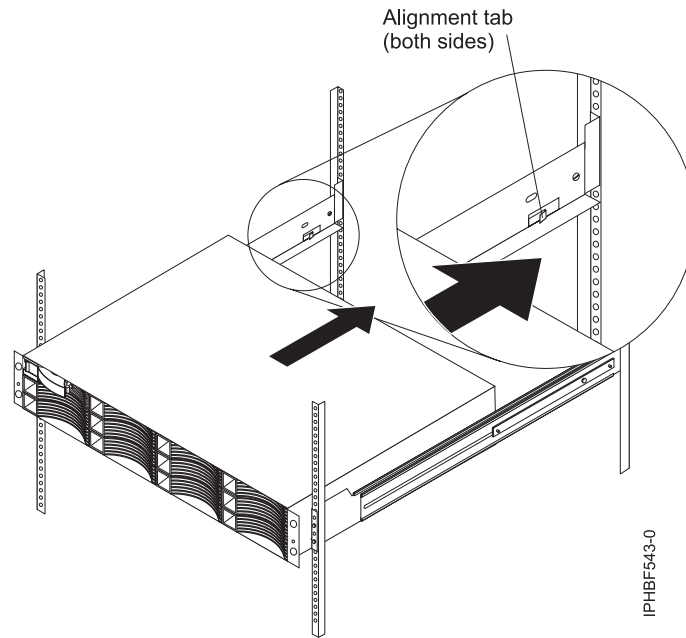

Figure 6. Installing the enclosure on the rails

- c. Secure the front of the disk drive enclosure to the rack cabinet with one M5 screw in the open hole in each bracket (no washer is required).

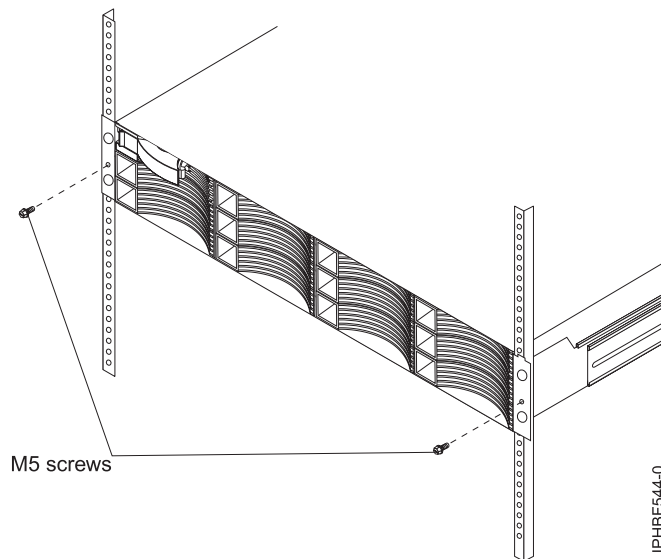

Figure 7. Installing the securing screws

- d. Secure the rear of the disk drive enclosure to each rail assembly with one M4 pan-head screw in the slotted hole on the outside of the storage enclosure chassis wall.
- e. Connect a power cord to each power supply. Use the power cord retention brackets (A) for strain relief to prevent the power cords from disconnecting accidentally.

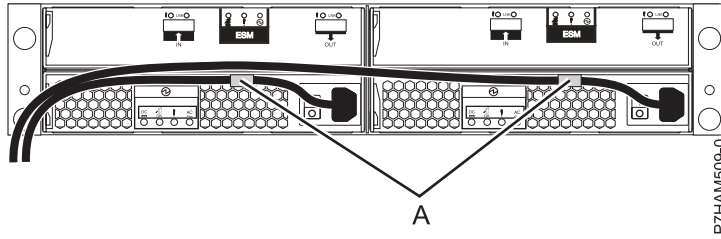

Figure 8. Routing the power cords through the cord retention brackets

- f. Install the left bezel, which contains the service indicators, and the right bezel. Fit the cutout on the top of the bezel over the tab on the chassis flange. Rotate the bezel down until it snaps into place. Make sure that the inside surface of the bezel is flush with the chassis.

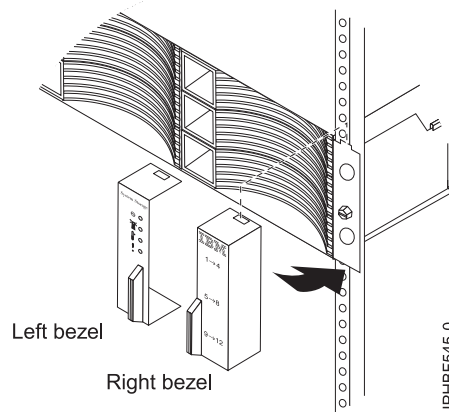

Figure 9. Attaching the side bezels

5. If you have disk units that require installation to the disk drive enclosure, repeat this step now for each disk unit to be installed into the enclosure.

Attention: Use the following precautions whenever you handle electronic components:

- Attach a wrist strap to an unpainted metal surface of your hardware to prevent electrostatic discharge from damaging your hardware.
- If you do not have a wrist strap, just prior to removing the product from ESD packaging and installing or replacing hardware, touch an unpainted metal surface of the system for a minimum of 5 seconds.
- Keep all electronic components in the shipping container or envelope until you are ready to install them.
- If you remove, then reinstall an electronic component, temporarily place the component on an ESD pad or blanket, if available.

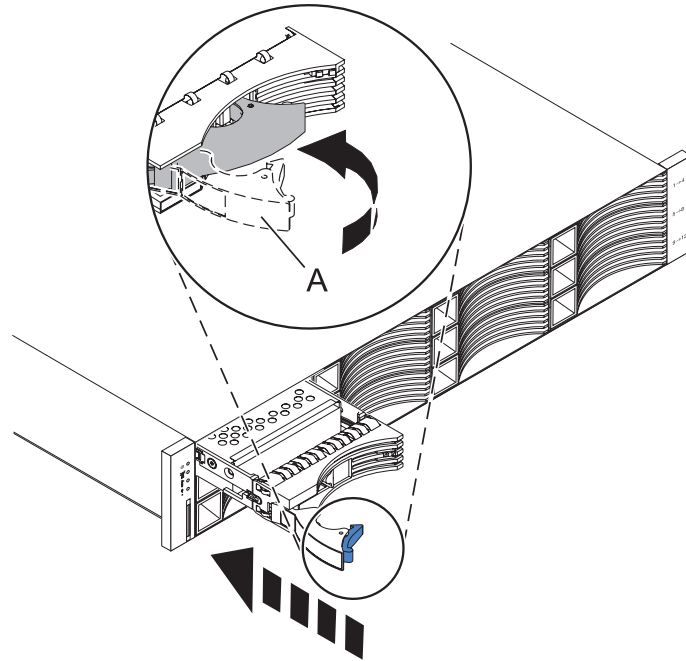

Figure 10. Installing a disk unit in the disk drive enclosure

- a. With the handle (**A**) in the unlocked position, support the bottom of the disk unit as you align it with the guide rails in the enclosure, as shown in the preceding figure.
- Note:** Do not hold the disk unit only by the handle.
- b. Slide the disk unit into the enclosure.
- c. Push the handle towards the disk unit to lock it into place.
6. Review information related to connecting this device:
 - a. Review the following information:

The SAS disk drive enclosure can hold up to 12 disk drives. The enclosure cannot be split into two independent groups.

The SAS disk drive enclosure supports the following operating systems:

- AIX®
- IBM i
- Linux
- VIOS

To determine the level of software that you need to support the SAS disk drive enclosure, see IBM Prerequisite (http://www-912.ibm.com/e_dir/eServerPrereq.nsf).

Tip: If you are planning to configure RAID arrays, ensure that you have the minimum number of available disks for each RAID level:

RAID 0

Minimum of one drive per array

RAID 5

Minimum of three drives per array

RAID 6

Minimum of four drives per array

RAID 10

Minimum of two drives per array

7. Review connector information pertaining to the hardware in your configuration as follows:
 - a. Adapter cables attach to ports at the rear of the systems in which the adapters are installed. To identify port locations for the system in your configuration, see “Server connectors” on page 15.
 - b. Adapters are cabled to the 5886 by using ports at the rear of the enclosure. To learn about the enclosure ports used in the following options, see “Enclosure connectors” on page 26.
8. Cable the disk drive enclosure to the server as follows:
 - a. Confirm that all adapters that you need to connect to the 5886 disk drive enclosure have been installed in the system. If the adapters have not been installed, complete the adapter installation procedure for your system before continuing with this task.
 - b. If the server requires an internal cable to be installed to produce an external SAS port for connection with the 5886 disk drive enclosure, confirm that the installation has been performed. Review the following list of systems that require the installation of an external SAS port, and then complete the action for your system, if required:

Remember: When installing or confirming the use of an external SAS port, record the location of the external SAS port on the server. Later in this procedure, you are instructed to install the external SAS cable to this server connector location.

- For installing the external SAS port on the IBM Power[®] 710 Express (8231-E2B and 8231-E1C) or IBM Power 730 Express (8231-E2B and 8231-E2C), see Installing the external SAS port in the 8231-E2B, 8231-E1C, 8231-E1D, 8231-E2C, or 8231-E2D (http://publib.boulder.ibm.com/infocenter/systems/scope/hw/topic/p7hal/installsasport_71x_73x.htm).
 - For installing the external SAS port on the IBM Power 720 Express (8202-E4B, 8202-E4C, and 8202-E4D) or IBM Power 740 Express (8205-E6B, 8205-E6C, and 8205-E6D), see Installing the external SAS port in the 8202-E4B, 8202-E4C, 8202-E4D, 8205-E6B, 8205-E6C, or 8205-E6D system (http://publib.boulder.ibm.com/infocenter/systems/scope/hw/topic/p7hal/installsasport_72x_74x.htm).
 - For installing the external SAS port on the IBM Power 750 Express (8233-E8B) or IBM Power 755 (8236-E8C), see Installing the external SAS port on an 8233-E8B or 8236-E8C (<http://publib.boulder.ibm.com/infocenter/systems/scope/hw/topic/p7hal/dasd550backplanesasfeature.htm>).
 - For installing the external SAS port on the IBM Power 770 (9117-MMB, 9117-MMC, and 9117-MMD) or IBM Power 780 (9179-MHB, 9179-MHC, and 9179-MHD), see Installing the external SAS port in the 9117-MMB, 9117-MMC, 9117-MMD, 9179-MHB, 9179-MHC, or 9179-MHD (<http://publib.boulder.ibm.com/infocenter/systems/scope/hw/topic/p7hal/9117installsasport.htm>).
- c. Locate the connection for each adapter for which you are using an external SAS cable to connect the 5886.

Note: The configuration figures in step 8d use adapter cards to represent the external server connections. The adapter card can represent one of the following connection types:

- The external port of an adapter that you confirmed in step 8a.
 - The external port of an internal adapter cable that you confirmed in step 8b.
- d. Choose one of the following options to cable the SAS adapter:
 - To perform a connection of one 5886 disk drive enclosure to a single SAS adapter by using a YO cable, go to step 8e on page 11.

- To perform a connection of two 5886 disk drive enclosures to a single SAS adapter by using YO cables, where each enclosure can be attached to an additional 5886 disk drive enclosure by using an EE cable, go to step 8f.
- To perform a connection of two 5886 disk drive enclosures to a SAS adapter pair by using X cables, where each enclosure can be attached to an additional 5886 disk drive enclosure by using an EE cable, go to step 8g on page 12.
- To perform a connection of one 5886 disk drive enclosure by using a YI cable to a system with support for a single SAS drawer, go to step 8h on page 13.

If your SAS configuration requirements are not supported by any of these options, go to step 8i on page 14.

- Perform the connection of one 5886 disk drive enclosure (**A**) to a single SAS adapter (**C**) by using a YO cable (**B**) as shown in Figure 11.

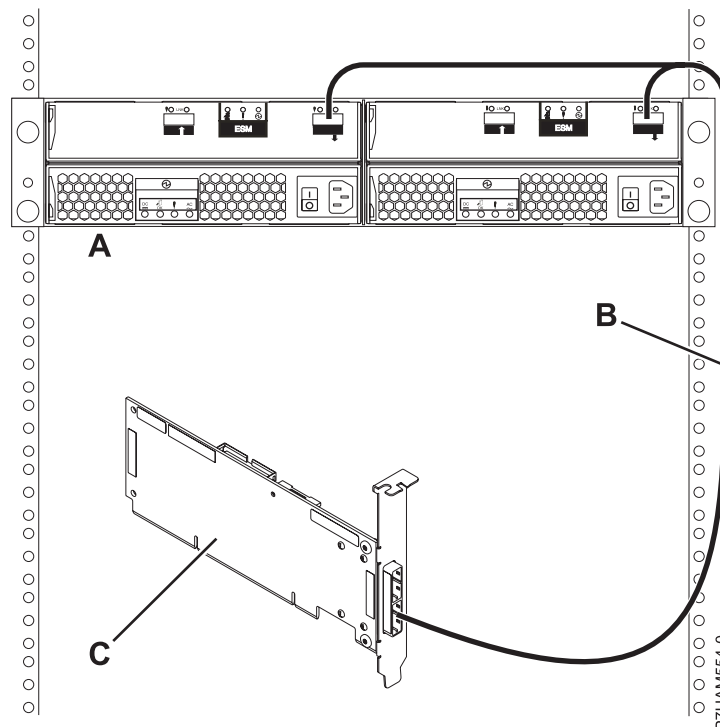

Figure 11. Connection of one 5886 disk drive enclosure to a single SAS adapter by using a YO cable

Go to step 8i on page 14.

- Perform the connection of two 5886 disk drive enclosures (**A and C**) to a single SAS adapter (**I**) by using YO cables (**G and H**), where each enclosure can be attached to an additional 5886 disk drive enclosure (**B and D**) by using two EE cables (**E and F**) as shown in Figure 12 on page 12.

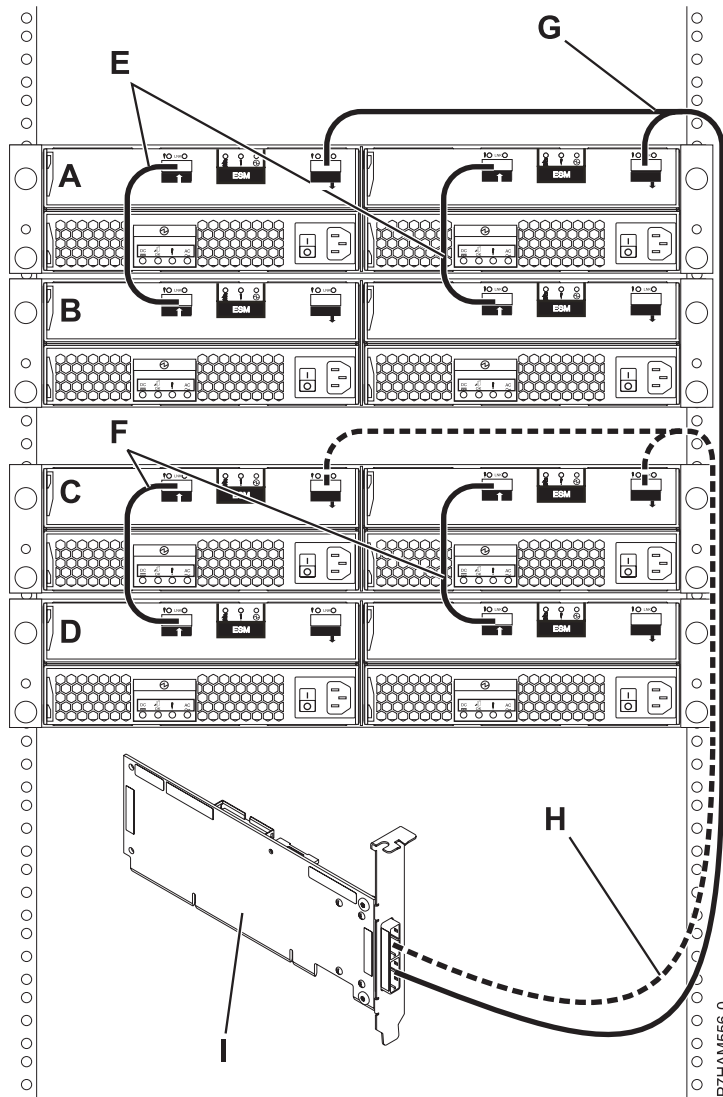

Figure 12. Connection of two 5886 disk drive enclosures to a single SAS adapter by using YO cables, where each enclosure can be attached to an additional 5886 disk drive enclosure by using two EE cables

Go to step 8i on page 14.

- g. Perform the connection of two 5886 disk drive enclosures (**A and C**) to a SAS adapter pair (**I**) by using X cables (**G and H**), where each enclosure can be attached to an additional 5886 disk drive enclosure (**B and D**) by using two EE cables (**E and F**) as shown in Figure 13 on page 13.

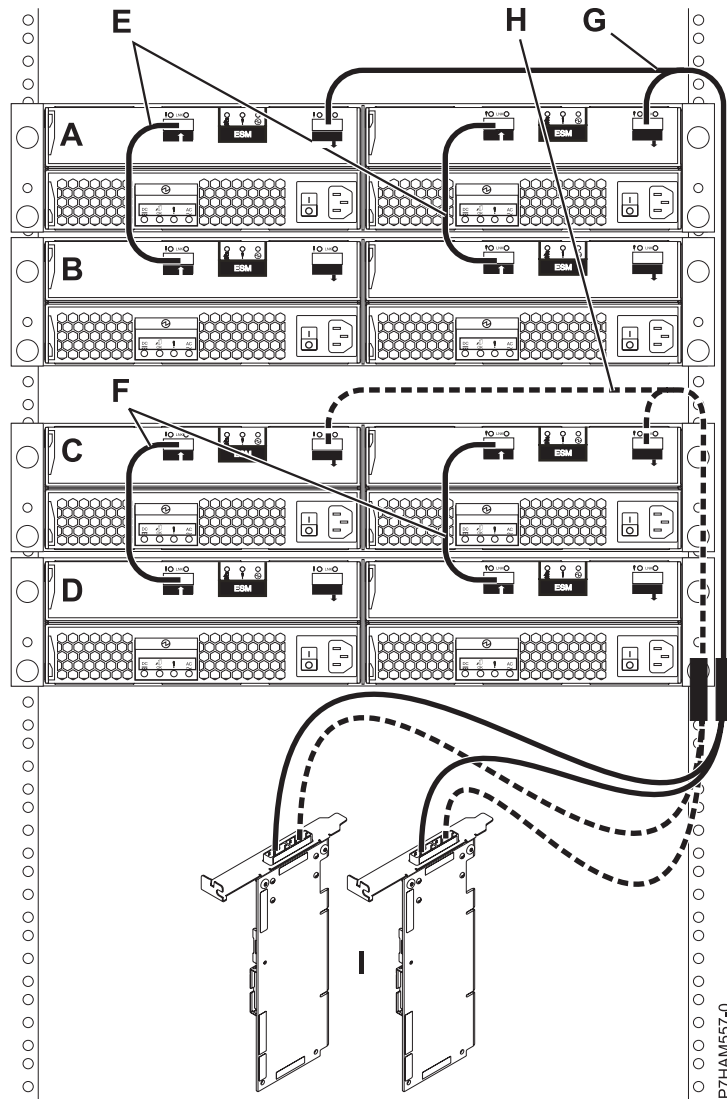

Figure 13. Connection of two 5886 disk drive enclosures to a SAS adapter pair by using X cables, where each enclosure can be attached to an additional 5886 disk drive enclosure by using two EE cables

Go to step 8i on page 14.

- h. Perform the connection of one 5886 disk drive enclosure (A) by using a YI cable (B) to a system with support for a single SAS drawer (C) as shown in Figure 14 on page 14.

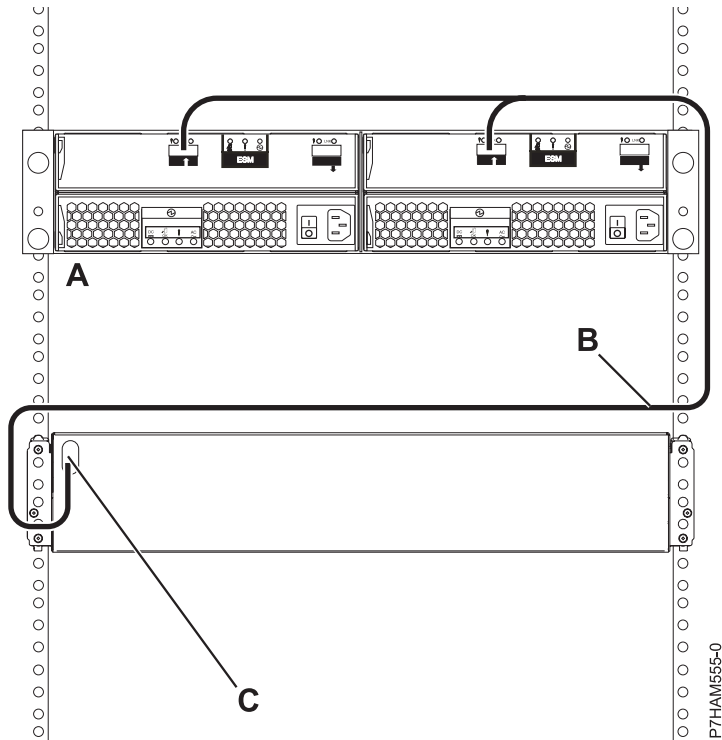

Figure 14. Connection of one 5886 disk drive enclosure by using a YI cable to a system with support for a single SAS drawer

Go to step 8i.

- i. For additional information to plan or complete your SAS cable installation, see Serial-attached SCSI cable planning (<http://publib.boulder.ibm.com/infocenter/systems/scope/hw/topic/p7had/p7hadsascabling.htm>).
9. Connect power cables and apply power to the 5886 disk drive enclosure.
10. Add the disk drives to the operating system you are using.
11. Verify the new configuration. To verify that the system or logical partition recognizes the disk drive enclosure, see Verifying the installed part (<http://publib.boulder.ibm.com/infocenter/systems/scope/hw/topic/p7haj/p7hajsmverify.htm>).

Reference information

Use the information in this section as needed to complete enclosure installation and configuration tasks.

Connector locations

Learn about 12X, system power control network (SPCN), and PCIe connector locations.

Server connectors

Learn about connector locations for servers.

Model 8202-E4B connector locations

Learn about connector locations on rack-mounted and stand-alone models.

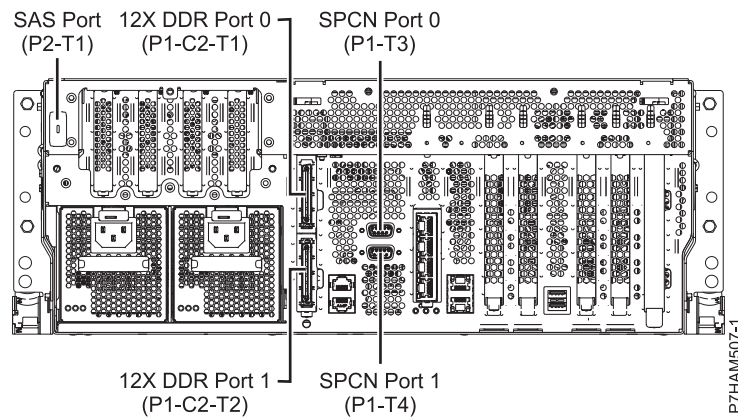

Figure 15. Model 8202-E4B connector locations on a rack-mounted model

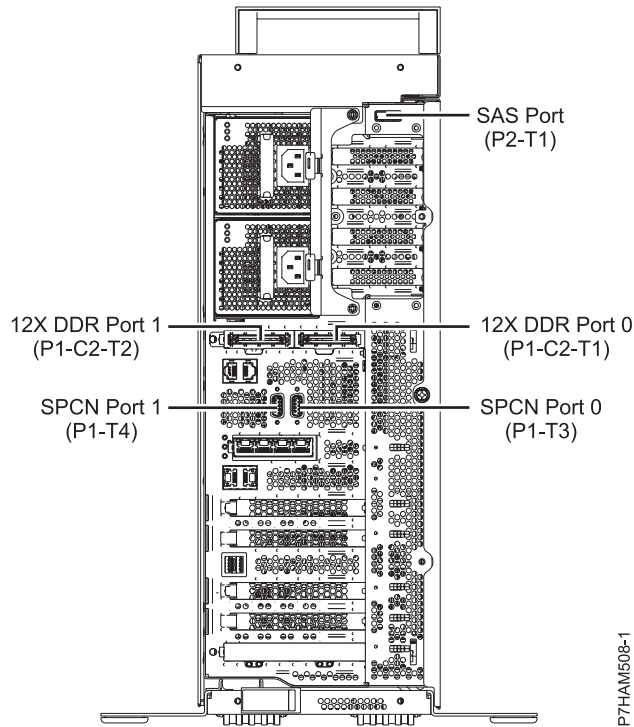

Figure 16. Model 8202-E4B connector locations on a stand-alone model

Model 8202-E4C connector locations

Learn about connector locations on rack-mounted models.

The 8202-E4C server provides cable connector locations for the following enclosures:

- Support for expansion units, as shown in the following figure, is as follows:
 - The card installed in the C1 slot can contain two 12X double data rate (DDR) cable ports. However, the C1 slot cannot provide both 12X DDR and PCIe cable ports.
 - The server contains a serial-attached SCSI (SAS) port.
- Support for disk drive enclosures, as shown in the following figure, is as follows:
 - The server contains a SAS port.
- Support for PCIe storage enclosures, as shown in the following figure, is as follows:
 - The card installed in the C1 slot can contain two PCIe cable ports. However, the C1 slot cannot provide both PCIe and 12X DDR cable ports.
 - The server contains a SAS port.

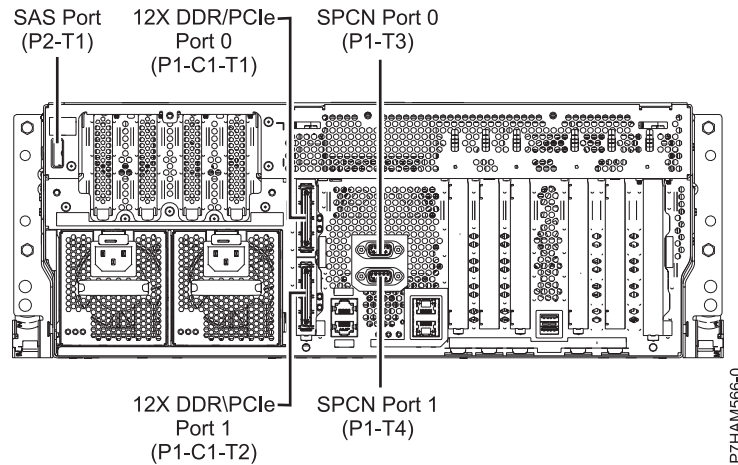

Figure 17. Model 8202-E4C connections for expansion units, disk drive enclosures, and PCIe storage enclosures

Model 8202-E4D connector locations

Learn about connector locations on rack-mounted models.

The 8202-E4D server provides cable connector locations for the following enclosures:

- Support for expansion units, as shown in the following figure, is as follows:
 - The card installed in the C1 slot can contain two 12X double data rate (DDR) cable ports. However, the C1 slot cannot provide both 12X DDR and PCIe cable ports.
 - The server contains a serial-attached SCSI (SAS) port.
- Support for disk drive enclosures, as shown in the following figure, is as follows:
 - The server contains a SAS port.
- Support for PCIe storage enclosures, as shown in the following figure, is as follows:
 - The card installed in the C1 slot can contain two PCIe cable ports. However, the C1 slot cannot provide both PCIe and 12X DDR cable ports.
 - The server contains a SAS port.

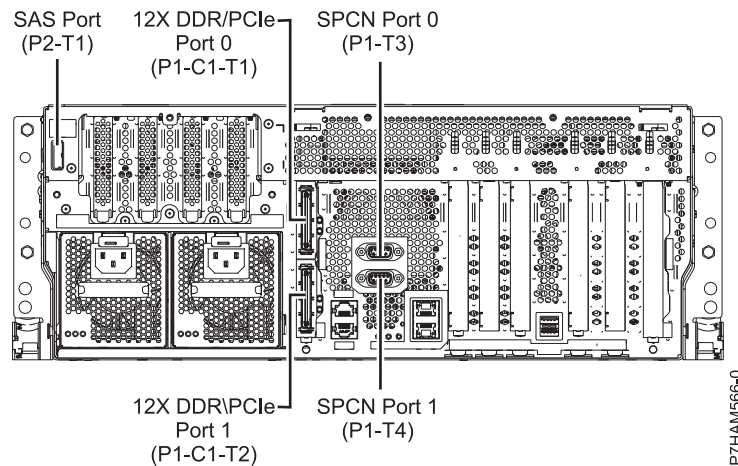

Figure 18. Model 8202-E4D connections for expansion units, disk drive enclosures, and PCIe storage enclosures

Model 8205-E6B connector locations

Learn about connector locations on rack-mounted and stand-alone models.

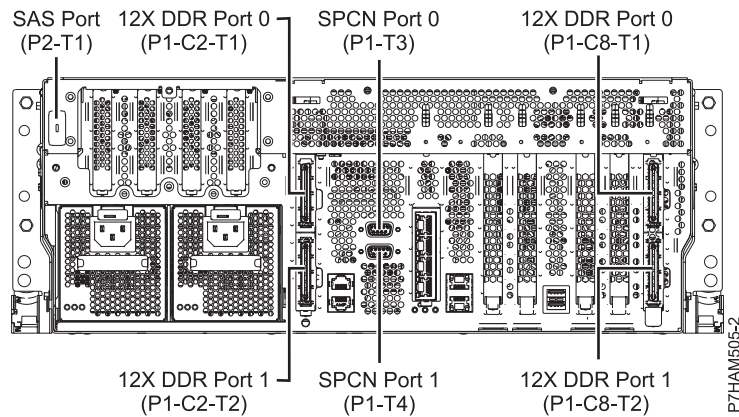

Figure 19. Model 8205-E6B connector locations on a rack-mounted model

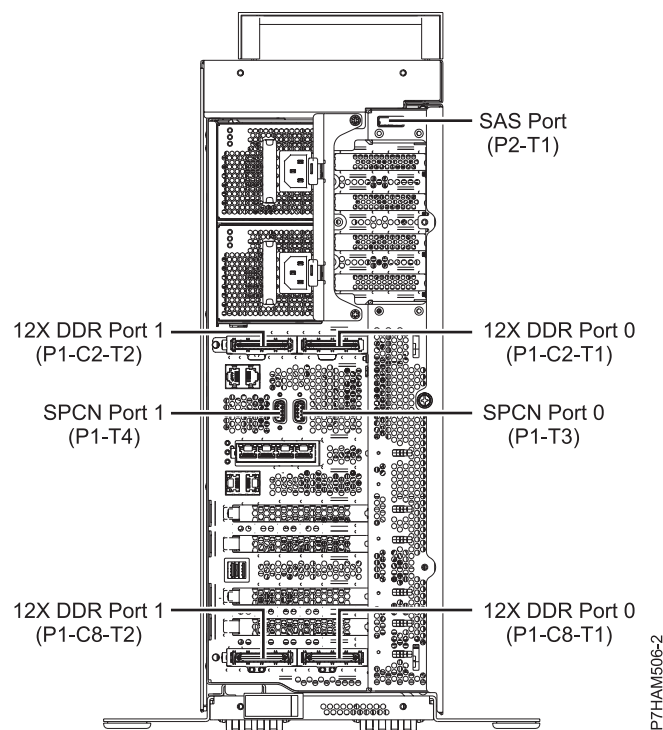

Figure 20. Model 8205-E6B connector locations on a stand-alone model

Model 8205-E6C connector locations

Learn about connector locations on rack-mounted models.

The 8205-E6C server provides cable connector locations for the following enclosures:

- Support for expansion units, as shown in the following figure, is as follows:
 - The card installed in the C1 slot can contain two 12X double data rate (DDR) cable ports. However, the C1 slot cannot provide both 12X DDR and PCIe cable ports.

- The card installed in the C8 slot can contain two 12X DDR cable ports. However, the C8 slot cannot provide both 12X DDR and PCIe cable ports.
- The port card type installed in the C1 slot can differ from the port card type installed in the C8 slot.
- The server contains a serial-attached SCSI (SAS) port.
- Support for disk drive enclosures, as shown in the following figure, is as follows:
 - The server contains a SAS port.
- Support for PCIe storage enclosures, as shown in the following figure, is as follows:
 - The card installed in the C1 slot can contain two PCIe cable ports. However, the C1 slot cannot provide both PCIe and 12X DDR cable ports.
 - The card installed in the C8 slot can contain two PCIe cable ports. However, the C8 slot cannot provide both PCIe and 12X DDR cable ports.
 - The port card type installed in the C1 slot can differ from the port card type installed in the C8 slot.
 - The server contains a SAS port.

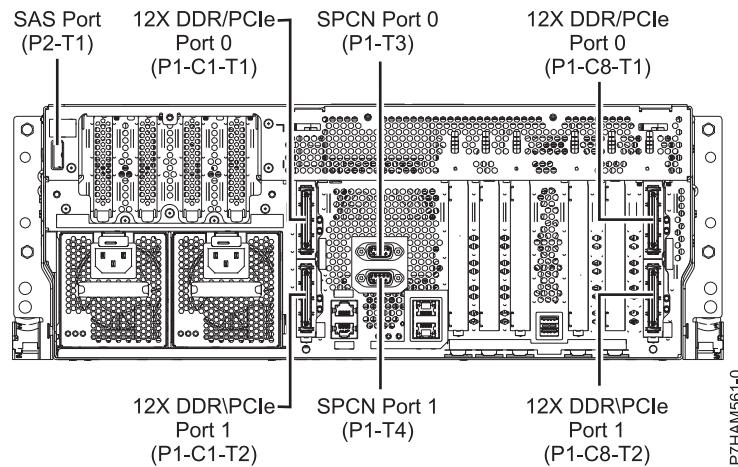

Figure 21. Model 8205-E6C connections for expansion units, disk drive enclosures, and PCIe storage enclosures

Model 8205-E6D connector locations

Learn about connector locations on rack-mounted models.

The 8205-E6D server provides cable connector locations for the following enclosures:

- Support for expansion units, as shown in the following figure, is as follows:
 - The card installed in the C1 slot can contain two 12X double data rate (DDR) cable ports. However, the C1 slot cannot provide both 12X DDR and PCIe cable ports.
 - The card installed in the C8 slot can contain two 12X DDR cable ports. However, the C8 slot cannot provide both 12X DDR and PCIe cable ports.
 - The port card type installed in the C1 slot can differ from the port card type installed in the C8 slot.
 - The server contains a serial-attached SCSI (SAS) port.
- Support for disk drive enclosures, as shown in the following figure, is as follows:
 - The server contains a SAS port.
- Support for PCIe storage enclosures, as shown in the following figure, is as follows:
 - The card installed in the C1 slot can contain two PCIe cable ports. However, the C1 slot cannot provide both PCIe and 12X DDR cable ports.
 - The card installed in the C8 slot can contain two PCIe cable ports. However, the C8 slot cannot provide both PCIe and 12X DDR cable ports.
 - The port card type installed in the C1 slot can differ from the port card type installed in the C8 slot.

- The server contains a SAS port.

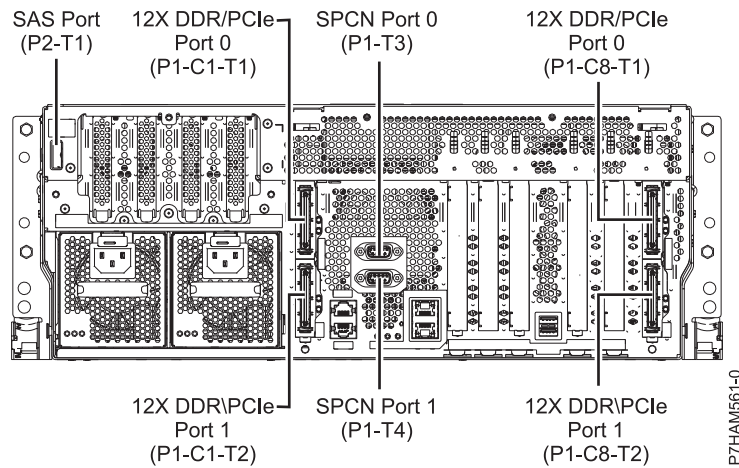

Figure 22. Model 8205-E6D connections for expansion units, disk drive enclosures, and PCIe storage enclosures

Model 8231-E1C connector locations

Learn about connector locations.

The 8231-E1C server provides cable connector locations for the following enclosures:

- Support for disk drive enclosures, as shown in the following figure, is as follows:
 - The server contains a serial-attached SCSI (SAS) port.
- Support for PCIe storage enclosures, as shown in the following figure, is as follows:
 - The card installed in the C1 slot can contain one PCIe cable port.
 - The server contains a SAS port.

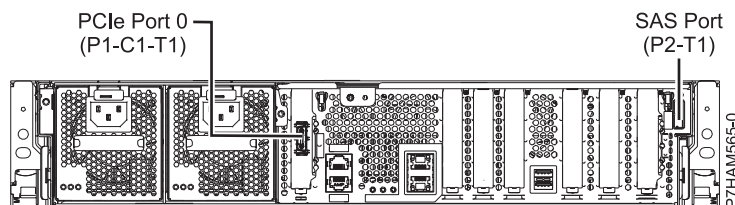

Figure 23. Model 8231-E1C connections for disk drive enclosures and PCIe storage enclosures

Model 8231-E2B connector locations

Learn about connector locations on rack-mounted models.

The 8231-E2B server provides cable connector locations for the following enclosures:

- Support for disk drive enclosures, as shown in the following figure, is as follows:
 - The server contains a SAS port.

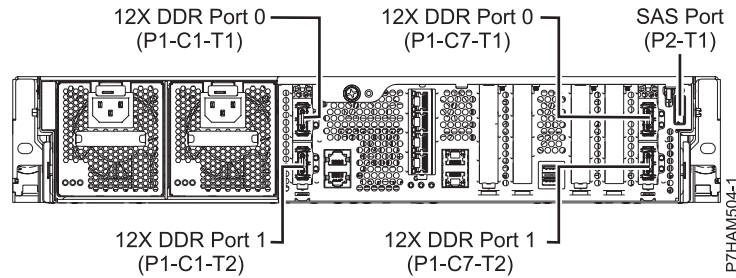

Figure 24. Model 8231-E2B connections for disk drive enclosures

- The 8231-E2B server provides no support for expansion units. The 12X DDR cable ports are for high speed system-to-system interconnection only.

Model 8231-E2C connector locations

Learn about connector locations.

The 8231-E2C server provides cable connector locations for the following enclosures:

- Support for expansion units, as shown in the following figure, is as follows:
 - The C1 slot must contain the system power control network (SPCN) card, and the C8 slot must contain the card with two 12X double data rate (DDR) cable ports.

Note: Installing the 12X DDR cable ports at this location causes both the C8 and C6 slot space to be occupied.

- The server cannot support both 12X DDR cable ports and PCIe cable ports at the same time.
- The server contains a serial-attached SCSI (SAS) port.
- Support for disk drive enclosures, as shown in the following figure, is as follows:
 - The server contains a SAS port.

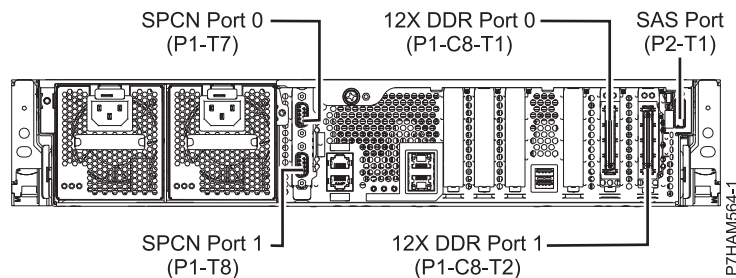

Figure 25. Model 8231-E2C connections for expansion units and disk drive enclosures

- Support for PCIe storage enclosures, as shown in the following figure, is as follows:
 - The card installed in the C1 slot can contain one PCIe cable port, and the card installed in the C8 slot can contain one PCIe cable port.
 - The server cannot support both PCIe cable ports and 12X DDR cable ports at the same time.
 - The server contains a SAS port.

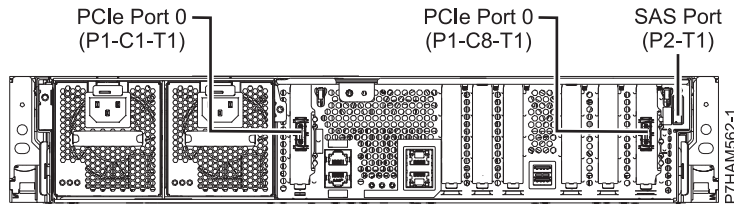

Figure 26. Model 8231-E2C connections for PCIe storage enclosures

Model 8233-E8B connector locations

Learn about connector locations on rack-mounted models.

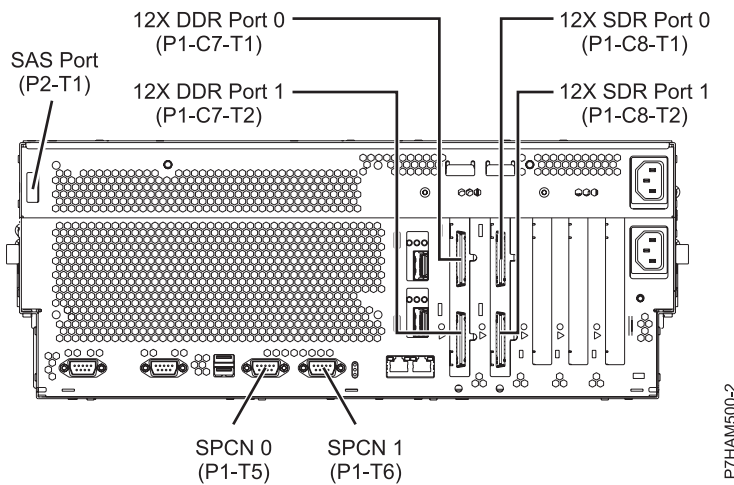

Figure 27. Model 8233-E8B connector locations on a rack-mounted model

Model 8248-L4T, 8408-E8D, or 9109-RMD connector locations

Learn about connector locations.

The 8248-L4T, 8408-E8D, and 9109-RMD servers provide cable connector locations for the following enclosures:

- Support for expansion units, as shown in the following figure, is as follows:
 - The card installed in the C2 slot can contain two 12X double data rate (DDR) cable ports. However, the C2 slot cannot provide both 12X DDR and PCIe cable ports.
 - The card installed in the C3 slot can contain two 12X DDR cable ports. However, the C3 slot cannot provide both 12X DDR and PCIe cable ports.
- Support for disk drive enclosures, as shown in the following figure, is as follows:
 - The server contains a SAS port.
- Support for PCIe storage enclosures, as shown in the following figure, is as follows:
 - The card installed in the C2 slot can contain two PCIe cable ports. However, the C2 slot cannot provide both PCIe and 12X DDR cable ports.
 - The card installed in the C3 slot can contain two PCIe cable ports. However, the C3 slot cannot provide both PCIe and 12X DDR cable ports.

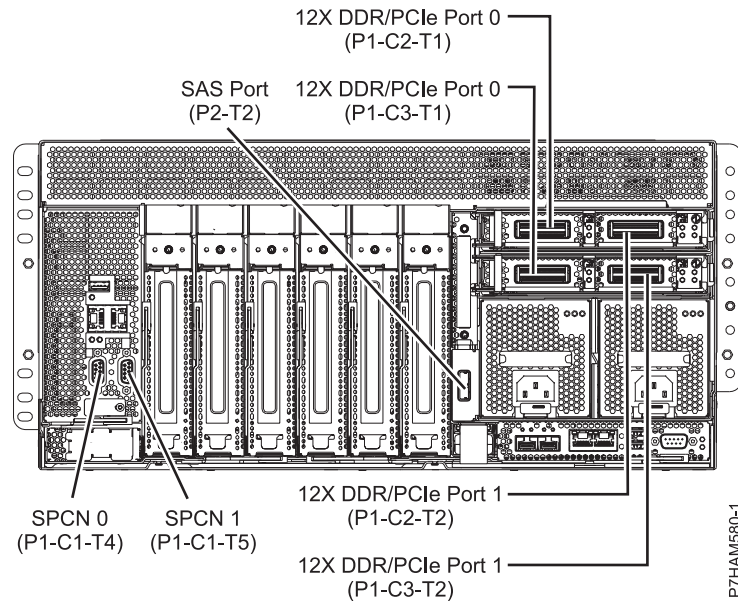

Figure 28. Model 8248-L4T, 8408-E8D, or 9109-RMD connector locations for expansion units, disk drive enclosures, and PCIe storage enclosures

Model 8412-EAD connector locations

Learn about connector locations.

The 8412-EAD server provides cable connector locations for the following enclosures:

- Support for expansion units, as shown in the following figure, is as follows:
 - The card installed in the C2 slot can contain two 12X double data rate (DDR) cable ports. However, the C2 slot cannot provide both 12X DDR and PCIe cable ports.
 - The card installed in the C3 slot can contain two 12X DDR cable ports. However, the C3 slot cannot provide both 12X DDR and PCIe cable ports.
- Support for disk drive enclosures, as shown in the following figure, is as follows:
 - The server contains a SAS port.
- Support for PCIe storage enclosures, as shown in the following figure, is as follows:
 - The card installed in the C2 slot can contain two PCIe cable ports. However, the C2 slot cannot provide both PCIe and 12X DDR cable ports.
 - The card installed in the C3 slot can contain two PCIe cable ports. However, the C3 slot cannot provide both PCIe and 12X DDR cable ports.

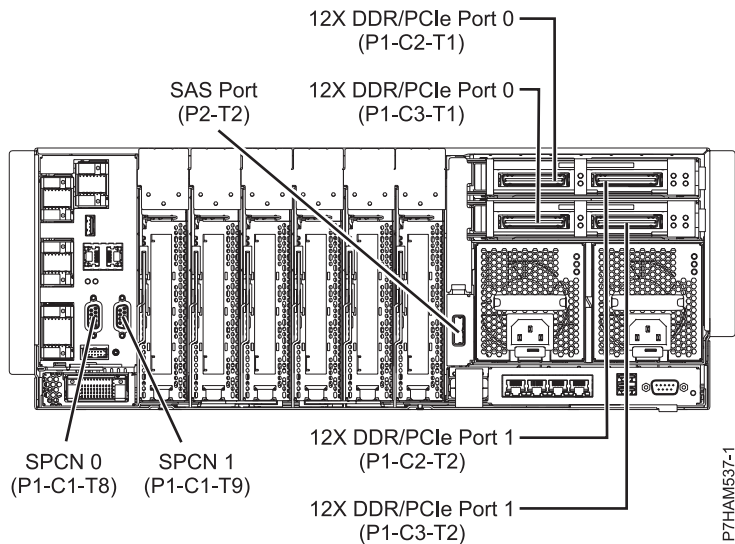

Figure 29. Model 8412-EAD connector locations for expansion units, disk drive enclosures, and PCIe storage enclosures

Model 9117-MMB or 9179-MHB connector locations

Learn about connector locations.

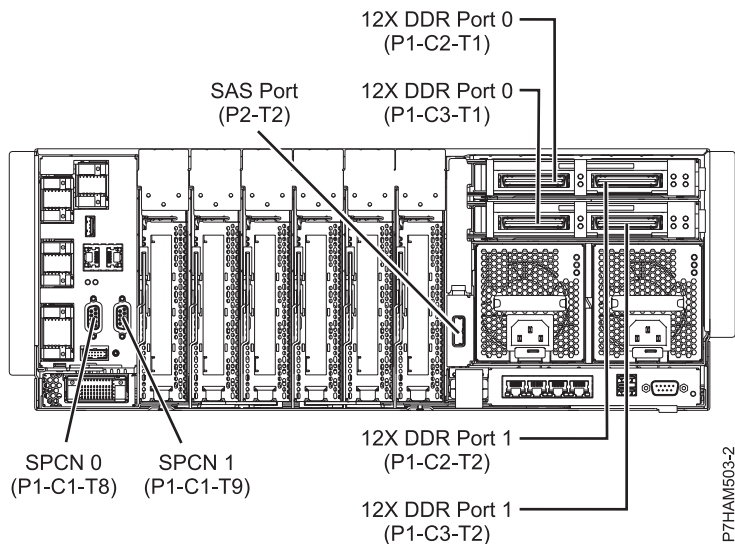

Figure 30. Model 9117-MMB or 9179-MHB connector locations

Model 9117-MMC or 9179-MHC connector locations

Learn about connector locations.

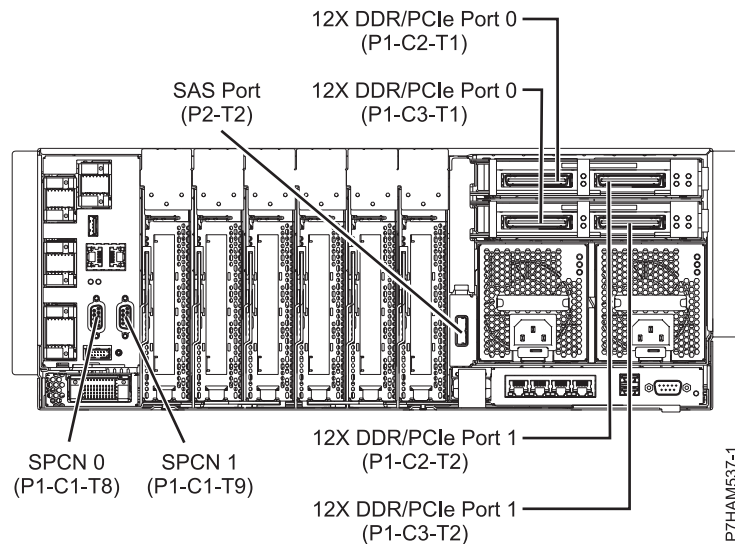

Figure 31. Model 9117-MMC or 9179-MHC connector locations

Model 9117-MMD or 9179-MHD connector locations

Learn about connector locations.

The 9117-MMD and 9179-MHD servers provide cable connector locations for the following enclosures:

- Support for expansion units, as shown in the following figure, is as follows:
 - The card installed in the C2 slot can contain two 12X double data rate (DDR) cable ports. However, the C2 slot cannot provide both 12X DDR and PCIe cable ports.
 - The card installed in the C3 slot can contain two 12X DDR cable ports. However, the C3 slot cannot provide both 12X DDR and PCIe cable ports.
- Support for disk drive enclosures, as shown in the following figure, is as follows:
 - The server contains a SAS port.
- Support for PCIe storage enclosures, as shown in the following figure, is as follows:
 - The card installed in the C2 slot can contain two PCIe cable ports. However, the C2 slot cannot provide both PCIe and 12X DDR cable ports.
 - The card installed in the C3 slot can contain two PCIe cable ports. However, the C3 slot cannot provide both PCIe and 12X DDR cable ports.

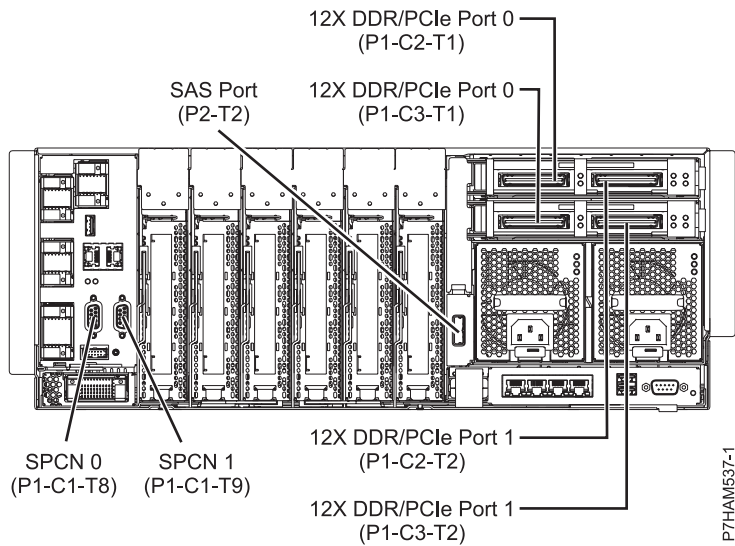

Figure 32. Model 9117-MMD or 9179-MHD connector locations for expansion units, disk drive enclosures, and PCIe storage enclosures

Enclosure connectors

Learn about connector locations for I/O enclosures.

Model 5886 connector locations

Learn about connector locations.

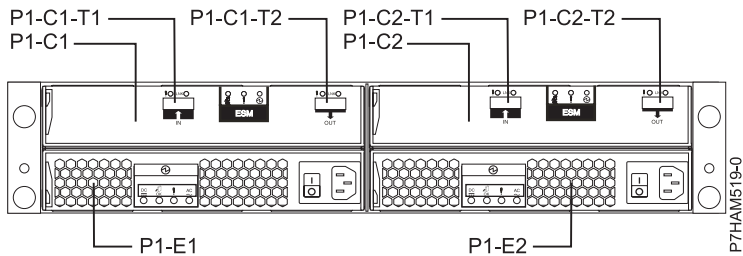

Figure 33. Model 5886 connector locations

Notices

This information was developed for products and services offered in the U.S.A.

The manufacturer may not offer the products, services, or features discussed in this document in other countries. Consult the manufacturer's representative for information on the products and services currently available in your area. Any reference to the manufacturer's product, program, or service is not intended to state or imply that only that product, program, or service may be used. Any functionally equivalent product, program, or service that does not infringe any intellectual property right of the manufacturer may be used instead. However, it is the user's responsibility to evaluate and verify the operation of any product, program, or service.

The manufacturer may have patents or pending patent applications covering subject matter described in this document. The furnishing of this document does not grant you any license to these patents. You can send license inquiries, in writing, to the manufacturer.

The following paragraph does not apply to the United Kingdom or any other country where such provisions are inconsistent with local law: THIS PUBLICATION IS PROVIDED "AS IS" WITHOUT WARRANTY OF ANY KIND, EITHER EXPRESS OR IMPLIED, INCLUDING, BUT NOT LIMITED TO, THE IMPLIED WARRANTIES OF NON-INFRINGEMENT, MERCHANTABILITY OR FITNESS FOR A PARTICULAR PURPOSE. Some states do not allow disclaimer of express or implied warranties in certain transactions, therefore, this statement may not apply to you.

This information could include technical inaccuracies or typographical errors. Changes are periodically made to the information herein; these changes will be incorporated in new editions of the publication. The manufacturer may make improvements and/or changes in the product(s) and/or the program(s) described in this publication at any time without notice.

Any references in this information to websites not owned by the manufacturer are provided for convenience only and do not in any manner serve as an endorsement of those websites. The materials at those websites are not part of the materials for this product and use of those websites is at your own risk.

The manufacturer may use or distribute any of the information you supply in any way it believes appropriate without incurring any obligation to you.

Any performance data contained herein was determined in a controlled environment. Therefore, the results obtained in other operating environments may vary significantly. Some measurements may have been made on development-level systems and there is no guarantee that these measurements will be the same on generally available systems. Furthermore, some measurements may have been estimated through extrapolation. Actual results may vary. Users of this document should verify the applicable data for their specific environment.

Information concerning products not produced by this manufacturer was obtained from the suppliers of those products, their published announcements or other publicly available sources. This manufacturer has not tested those products and cannot confirm the accuracy of performance, compatibility or any other claims related to products not produced by this manufacturer. Questions on the capabilities of products not produced by this manufacturer should be addressed to the suppliers of those products.

All statements regarding the manufacturer's future direction or intent are subject to change or withdrawal without notice, and represent goals and objectives only.

The manufacturer's prices shown are the manufacturer's suggested retail prices, are current and are subject to change without notice. Dealer prices may vary.

This information is for planning purposes only. The information herein is subject to change before the products described become available.

This information contains examples of data and reports used in daily business operations. To illustrate them as completely as possible, the examples include the names of individuals, companies, brands, and products. All of these names are fictitious and any similarity to the names and addresses used by an actual business enterprise is entirely coincidental.

If you are viewing this information in softcopy, the photographs and color illustrations may not appear.

The drawings and specifications contained herein shall not be reproduced in whole or in part without the written permission of the manufacturer.

The manufacturer has prepared this information for use with the specific machines indicated. The manufacturer makes no representations that it is suitable for any other purpose.

The manufacturer's computer systems contain mechanisms designed to reduce the possibility of undetected data corruption or loss. This risk, however, cannot be eliminated. Users who experience unplanned outages, system failures, power fluctuations or outages, or component failures must verify the accuracy of operations performed and data saved or transmitted by the system at or near the time of the outage or failure. In addition, users must establish procedures to ensure that there is independent data verification before relying on such data in sensitive or critical operations. Users should periodically check the manufacturer's support websites for updated information and fixes applicable to the system and related software.

Homologation statement

This product may not be certified in your country for connection by any means whatsoever to interfaces of public telecommunications networks. Further certification may be required by law prior to making any such connection. Contact an IBM representative or reseller for any questions.

Trademarks

IBM, the IBM logo, and ibm.com are trademarks or registered trademarks of International Business Machines Corp., registered in many jurisdictions worldwide. Other product and service names might be trademarks of IBM or other companies. A current list of IBM trademarks is available on the web at Copyright and trademark information at www.ibm.com/legal/copytrade.shtml.

Linux is a registered trademark of Linus Torvalds in the United States, other countries, or both.

Electronic emission notices

When attaching a monitor to the equipment, you must use the designated monitor cable and any interference suppression devices supplied with the monitor.

Class A Notices

The following Class A statements apply to the IBM servers that contain the POWER7[®] processor and its features unless designated as electromagnetic compatibility (EMC) Class B in the feature information.

Federal Communications Commission (FCC) statement

Note: This equipment has been tested and found to comply with the limits for a Class A digital device, pursuant to Part 15 of the FCC Rules. These limits are designed to provide reasonable protection against harmful interference when the equipment is operated in a commercial environment. This equipment generates, uses, and can radiate radio frequency energy and, if not installed and used in accordance with

the instruction manual, may cause harmful interference to radio communications. Operation of this equipment in a residential area is likely to cause harmful interference, in which case the user will be required to correct the interference at his own expense.

Properly shielded and grounded cables and connectors must be used in order to meet FCC emission limits. IBM is not responsible for any radio or television interference caused by using other than recommended cables and connectors or by unauthorized changes or modifications to this equipment. Unauthorized changes or modifications could void the user's authority to operate the equipment.

This device complies with Part 15 of the FCC rules. Operation is subject to the following two conditions: (1) this device may not cause harmful interference, and (2) this device must accept any interference received, including interference that may cause undesired operation.

Industry Canada Compliance Statement

This Class A digital apparatus complies with Canadian ICES-003.

Avis de conformité à la réglementation d'Industrie Canada

Cet appareil numérique de la classe A est conforme à la norme NMB-003 du Canada.

European Community Compliance Statement

This product is in conformity with the protection requirements of EU Council Directive 2004/108/EC on the approximation of the laws of the Member States relating to electromagnetic compatibility. IBM cannot accept responsibility for any failure to satisfy the protection requirements resulting from a non-recommended modification of the product, including the fitting of non-IBM option cards.

This product has been tested and found to comply with the limits for Class A Information Technology Equipment according to European Standard EN 55022. The limits for Class A equipment were derived for commercial and industrial environments to provide reasonable protection against interference with licensed communication equipment.

European Community contact:
IBM Deutschland GmbH
Technical Regulations, Department M372
IBM-Allee 1, 71139 Ehningen, Germany
Tele: +49 7032 15 2941
email: lugi@de.ibm.com

Warning: This is a Class A product. In a domestic environment, this product may cause radio interference, in which case the user may be required to take adequate measures.

VCCI Statement - Japan

この装置は、クラスA 情報技術装置です。この装置を家庭環境で使用すると電波妨害を引き起こすことがあります。この場合には使用者が適切な対策を講ずるよう要求されることがあります。

VCCI-A

The following is a summary of the VCCI Japanese statement in the box above:

This is a Class A product based on the standard of the VCCI Council. If this equipment is used in a domestic environment, radio interference may occur, in which case, the user may be required to take corrective actions.

Japanese Electronics and Information Technology Industries Association (JEITA) Confirmed Harmonics Guideline (products less than or equal to 20 A per phase)

高調波ガイドライン適合品

Japanese Electronics and Information Technology Industries Association (JEITA) Confirmed Harmonics Guideline with Modifications (products greater than 20 A per phase)

高調波ガイドライン準用品

Electromagnetic Interference (EMI) Statement - People's Republic of China

声 明

此为 A 级产品,在生活环境中,
该产品可能会造成无线电干扰。
在这种情况下,可能需要用户对其
干扰采取切实可行的措施。

Declaration: This is a Class A product. In a domestic environment this product may cause radio interference in which case the user may need to perform practical action.

Electromagnetic Interference (EMI) Statement - Taiwan

警告使用者：

這是甲類的資訊產品，在
居住的環境中使用時，可
能會造成射頻干擾，在這
種情況下，使用者會被要
求採取某些適當的對策。

The following is a summary of the EMI Taiwan statement above.

Warning: This is a Class A product. In a domestic environment this product may cause radio interference in which case the user will be required to take adequate measures.

IBM Taiwan Contact Information:

台灣IBM 產品服務聯絡方式：
台灣國際商業機器股份有限公司
台北市松仁路7號3樓
電話：0800-016-888

Electromagnetic Interference (EMI) Statement - Korea

이 기기는 업무용(A급)으로 전자파적합기기로서 판매자 또는 사용자는 이 점을 주의하시기 바라며, 가정외의 지역에서 사용하는 것을 목적으로 합니다.

Germany Compliance Statement

Deutschsprachiger EU Hinweis: Hinweis für Geräte der Klasse A EU-Richtlinie zur Elektromagnetischen Verträglichkeit

Dieses Produkt entspricht den Schutzanforderungen der EU-Richtlinie 2004/108/EG zur Angleichung der Rechtsvorschriften über die elektromagnetische Verträglichkeit in den EU-Mitgliedsstaaten und hält die Grenzwerte der EN 55022 Klasse A ein.

Um dieses sicherzustellen, sind die Geräte wie in den Handbüchern beschrieben zu installieren und zu betreiben. Des Weiteren dürfen auch nur von der IBM empfohlene Kabel angeschlossen werden. IBM übernimmt keine Verantwortung für die Einhaltung der Schutzanforderungen, wenn das Produkt ohne Zustimmung von IBM verändert bzw. wenn Erweiterungskomponenten von Fremdherstellern ohne Empfehlung von IBM gesteckt/eingebaut werden.

EN 55022 Klasse A Geräte müssen mit folgendem Warnhinweis versehen werden:

"Warnung: Dieses ist eine Einrichtung der Klasse A. Diese Einrichtung kann im Wohnbereich Funk-Störungen verursachen; in diesem Fall kann vom Betreiber verlangt werden, angemessene Maßnahmen zu ergreifen und dafür aufzukommen."

Deutschland: Einhaltung des Gesetzes über die elektromagnetische Verträglichkeit von Geräten

Dieses Produkt entspricht dem "Gesetz über die elektromagnetische Verträglichkeit von Geräten (EMVG)". Dies ist die Umsetzung der EU-Richtlinie 2004/108/EG in der Bundesrepublik Deutschland.

Zulassungsbescheinigung laut dem Deutschen Gesetz über die elektromagnetische Verträglichkeit von Geräten (EMVG) (bzw. der EMC EG Richtlinie 2004/108/EG) für Geräte der Klasse A

Dieses Gerät ist berechtigt, in Übereinstimmung mit dem Deutschen EMVG das EG-Konformitätszeichen - CE - zu führen.

Verantwortlich für die Einhaltung der EMV Vorschriften ist der Hersteller:
International Business Machines Corp.
New Orchard Road
Armonk, New York 10504
Tel: 914-499-1900

Der verantwortliche Ansprechpartner des Herstellers in der EU ist:
IBM Deutschland GmbH
Technical Regulations, Abteilung M372
IBM-Allee 1, 71139 Ehningen, Germany
Tel: +49 7032 15 2941
email: lugi@de.ibm.com

Generelle Informationen:

Das Gerät erfüllt die Schutzanforderungen nach EN 55024 und EN 55022 Klasse A.

Electromagnetic Interference (EMI) Statement - Russia

ВНИМАНИЕ! Настоящее изделие относится к классу А.
В жилых помещениях оно может создавать
радиопомехи, для снижения которых необходимы
дополнительные меры

Class B Notices

The following Class B statements apply to features designated as electromagnetic compatibility (EMC) Class B in the feature installation information.

Federal Communications Commission (FCC) statement

This equipment has been tested and found to comply with the limits for a Class B digital device, pursuant to Part 15 of the FCC Rules. These limits are designed to provide reasonable protection against harmful interference in a residential installation.

This equipment generates, uses, and can radiate radio frequency energy and, if not installed and used in accordance with the instructions, may cause harmful interference to radio communications. However, there is no guarantee that interference will not occur in a particular installation.

If this equipment does cause harmful interference to radio or television reception, which can be determined by turning the equipment off and on, the user is encouraged to try to correct the interference by one or more of the following measures:

- Reorient or relocate the receiving antenna.
- Increase the separation between the equipment and receiver.
- Connect the equipment into an outlet on a circuit different from that to which the receiver is connected.
- Consult an IBM-authorized dealer or service representative for help.

Properly shielded and grounded cables and connectors must be used in order to meet FCC emission limits. Proper cables and connectors are available from IBM-authorized dealers. IBM is not responsible for

any radio or television interference caused by unauthorized changes or modifications to this equipment. Unauthorized changes or modifications could void the user's authority to operate this equipment.

This device complies with Part 15 of the FCC rules. Operation is subject to the following two conditions: (1) this device may not cause harmful interference, and (2) this device must accept any interference received, including interference that may cause undesired operation.

Industry Canada Compliance Statement

This Class B digital apparatus complies with Canadian ICES-003.

Avis de conformité à la réglementation d'Industrie Canada

Cet appareil numérique de la classe B est conforme à la norme NMB-003 du Canada.

European Community Compliance Statement

This product is in conformity with the protection requirements of EU Council Directive 2004/108/EC on the approximation of the laws of the Member States relating to electromagnetic compatibility. IBM cannot accept responsibility for any failure to satisfy the protection requirements resulting from a non-recommended modification of the product, including the fitting of non-IBM option cards.

This product has been tested and found to comply with the limits for Class B Information Technology Equipment according to European Standard EN 55022. The limits for Class B equipment were derived for typical residential environments to provide reasonable protection against interference with licensed communication equipment.

European Community contact:
IBM Deutschland GmbH
Technical Regulations, Department M372
IBM-Allee 1, 71139 Ehningen, Germany
Tele: +49 7032 15 2941
email: lugi@de.ibm.com

VCCI Statement - Japan

この装置は、クラスB情報技術装置です。この装置は、家庭環境で使用することを目的としていますが、この装置がラジオやテレビジョン受信機に近接して使用されると、受信障害を引き起こすことがあります。

取扱説明書に従って正しい取り扱いをして下さい。 VCCI-B

Japanese Electronics and Information Technology Industries Association (JEITA) Confirmed Harmonics Guideline (products less than or equal to 20 A per phase)

高調波ガイドライン適合品

**Japanese Electronics and Information Technology Industries Association (JEITA)
Confirmed Harmonics Guideline with Modifications (products greater than 20 A per
phase)**

高調波ガイドライン準用品

IBM Taiwan Contact Information

台灣IBM 產品服務聯絡方式：
台灣國際商業機器股份有限公司
台北市松仁路7號3樓
電話：0800-016-888

Electromagnetic Interference (EMI) Statement - Korea

이 기기는 가정용(B급)으로 전자파적합기기로서 주로 가정에서 사용하는 것을 목적으로 하며, 모든 지역에서 사용할 수 있습니다.

Germany Compliance Statement

**Deutschsprachiger EU Hinweis: Hinweis für Geräte der Klasse B EU-Richtlinie zur
Elektromagnetischen Verträglichkeit**

Dieses Produkt entspricht den Schutzanforderungen der EU-Richtlinie 2004/108/EG zur Angleichung der Rechtsvorschriften über die elektromagnetische Verträglichkeit in den EU-Mitgliedsstaaten und hält die Grenzwerte der EN 55022 Klasse B ein.

Um dieses sicherzustellen, sind die Geräte wie in den Handbüchern beschrieben zu installieren und zu betreiben. Des Weiteren dürfen auch nur von der IBM empfohlene Kabel angeschlossen werden. IBM übernimmt keine Verantwortung für die Einhaltung der Schutzanforderungen, wenn das Produkt ohne Zustimmung von IBM verändert bzw. wenn Erweiterungskomponenten von Fremdherstellern ohne Empfehlung von IBM gesteckt/eingebaut werden.

Deutschland: Einhaltung des Gesetzes über die elektromagnetische Verträglichkeit von Geräten

Dieses Produkt entspricht dem "Gesetz über die elektromagnetische Verträglichkeit von Geräten (EMVG)". Dies ist die Umsetzung der EU-Richtlinie 2004/108/EG in der Bundesrepublik Deutschland.

**Zulassungsbescheinigung laut dem Deutschen Gesetz über die elektromagnetische Verträglichkeit von
Geräten (EMVG) (bzw. der EMC EG Richtlinie 2004/108/EG) für Geräte der Klasse B**

Dieses Gerät ist berechtigt, in Übereinstimmung mit dem Deutschen EMVG das EG-Konformitätszeichen - CE - zu führen.

Verantwortlich für die Einhaltung der EMV Vorschriften ist der Hersteller:

International Business Machines Corp.

New Orchard Road

Armonk, New York 10504

Tel: 914-499-1900

Der verantwortliche Ansprechpartner des Herstellers in der EU ist:

IBM Deutschland GmbH

Technical Regulations, Abteilung M372

IBM-Allee 1, 71139 Ehningen, Germany

Tel: +49 7032 15 2941

email: lugi@de.ibm.com

Generelle Informationen:

Das Gerät erfüllt die Schutzanforderungen nach EN 55024 und EN 55022 Klasse B.

Terms and conditions

Permissions for the use of these publications are granted subject to the following terms and conditions.

Applicability: These terms and conditions are in addition to any terms of use for the IBM website.

Personal Use: You may reproduce these publications for your personal, noncommercial use provided that all proprietary notices are preserved. You may not distribute, display or make derivative works of these publications, or any portion thereof, without the express consent of IBM.

Commercial Use: You may reproduce, distribute and display these publications solely within your enterprise provided that all proprietary notices are preserved. You may not make derivative works of these publications, or reproduce, distribute or display these publications or any portion thereof outside your enterprise, without the express consent of IBM.

Rights: Except as expressly granted in this permission, no other permissions, licenses or rights are granted, either express or implied, to the Publications or any information, data, software or other intellectual property contained therein.

IBM reserves the right to withdraw the permissions granted herein whenever, in its discretion, the use of the publications is detrimental to its interest or, as determined by IBM, the above instructions are not being properly followed.

You may not download, export or re-export this information except in full compliance with all applicable laws and regulations, including all United States export laws and regulations.

IBM MAKES NO GUARANTEE ABOUT THE CONTENT OF THESE PUBLICATIONS. THE PUBLICATIONS ARE PROVIDED "AS-IS" AND WITHOUT WARRANTY OF ANY KIND, EITHER EXPRESSED OR IMPLIED, INCLUDING BUT NOT LIMITED TO IMPLIED WARRANTIES OF MERCHANTABILITY, NON-INFRINGEMENT, AND FITNESS FOR A PARTICULAR PURPOSE.



Part Number: 00L4945

Printed in USA

GI11-2910-08



(1P) P/N: 00L4945

