

Power Systems

*Serial-attached SCSI RAID enablement  
and cache battery pack*

**IBM**



Power Systems

*Serial-attached SCSI RAID enablement  
and cache battery pack*

**IBM**

**Note**

Before using this information and the product it supports, read the information in "Safety notices" on page v, "Notices" on page 65, the *IBM Systems Safety Notices* manual, G229-9054, and the *IBM Environmental Notices and User Guide*, Z125-5823.

This edition applies to IBM Power Systems servers that contain the POWER7 processor and to all associated models.

© **Copyright IBM Corporation 2010.**

US Government Users Restricted Rights – Use, duplication or disclosure restricted by GSA ADP Schedule Contract with IBM Corp.



---

# Contents

<b>Safety notices</b> . . . . .	<b>v</b>
<b>SAS RAID enablement</b> . . . . .	<b>1</b>
<b>What's new in SAS RAID enablement</b> . . . . .	<b>3</b>
<b>RAID enablement card and auxiliary cache card in a model 8233-E8B</b> . . . . .	<b>5</b>
Installing the model 8233-E8B Redundant Array of Independent Disks enablement card . . . . .	5
Preparing the system . . . . .	5
Installing the RAID enablement card . . . . .	6
Installing the model 8233-E8B auxiliary cache card. . . . .	8
Preparing the system . . . . .	8
Installing the auxiliary cache card . . . . .	9
Removing the model 8233-E8B auxiliary cache card . . . . .	11
Preparing the system . . . . .	11
Removing the auxiliary cache card . . . . .	12
Replacing the model 8233-E8B auxiliary cache card . . . . .	13
Removing the model 8233-E8B Redundant Array of Independent Disks enablement card . . . . .	15
Preparing the system . . . . .	15
Removing the RAID enablement card . . . . .	16
Replacing the model 8233-E8B Redundant Array of Independent Disks enablement card . . . . .	17
Managing the cache battery pack . . . . .	19
Removing and installing the cache battery pack . . . . .	19
<b>Common procedures for installable features</b> . . . . .	<b>25</b>
<b>Before you begin</b> . . . . .	<b>27</b>
<b>Identifying a part</b> . . . . .	<b>31</b>
Control panel LEDs. . . . .	31
Identifying a failing part in an AIX system or logical partition . . . . .	32
Locating a failing part in an AIX system or logical partition . . . . .	32
Activating the indicator light for the failing part . . . . .	33
Deactivating the failing-part indicator light. . . . .	33
Identifying a failing part in an IBM i system or logical partition. . . . .	33
Activating the failing-part indicator light . . . . .	33
Deactivating the failing-part indicator light. . . . .	34
Identifying a failing part in a Linux system or logical partition . . . . .	35
Locating a failing part in a Linux system or logical partition . . . . .	35
Finding the location code of a failing part in a Linux system or logical partition . . . . .	35
Activating the indicator light for the failing part . . . . .	35
Deactivating the failing-part indicator light. . . . .	35
Locating a failing part in a Virtual I/O Server system or logical partition. . . . .	36
Identifying a part by using the Virtual I/O Server . . . . .	36
<b>Starting the system or logical partition</b> . . . . .	<b>37</b>
Starting a system that is not managed by an HMC or an SDMC. . . . .	37
Starting a system or logical partition by using the HMC . . . . .	38
Starting a system or virtual server by using the SDMC . . . . .	38
<b>Stopping a system or logical partition</b> . . . . .	<b>41</b>
Stopping a system that is not managed by an HMC or an SDMC . . . . .	41
Stopping a system by using the HMC . . . . .	42

Stopping a system by using the SDMC . . . . .	43
<b>Removing and replacing covers for the 8233-E8B or 8236-E8C system . . . . .</b>	<b>45</b>
Removing the front cover from an 8233-E8B or 8236-E8C system . . . . .	45
Installing the front cover on an 8233-E8B or 8236-E8C system . . . . .	45
Removing the service access cover from an 8233-E8B or 8236-E8C system . . . . .	46
Installing the service access cover on an 8233-E8B or 8236-E8C system. . . . .	47
<b>Placing the rack-mounted 8233-E8B or 8236-E8C system into the service position or operating position . . . . .</b>	<b>49</b>
Placing the 8233-E8B or 8236-E8C in the service position . . . . .	49
Placing the 8233-E8B or 8236-E8C in the operating position . . . . .	51
<b>Verifying the installed part . . . . .</b>	<b>53</b>
Verifying an installed feature or replaced part in an AIX system or logical partition . . . . .	53
Verifying the installed part in an IBM i system or logical partition . . . . .	55
Deactivating the failing-part indicator light . . . . .	56
Verifying the installed part in a Linux system or logical partition . . . . .	56
Verifying an installed part by using stand-alone diagnostics . . . . .	57
Verifying the installed part by using the HMC. . . . .	58
Activating and deactivating LEDs by using the HMC . . . . .	59
Deactivating a system attention LED or partition LED by using the HMC . . . . .	59
Activating or deactivating an identify LED by using the HMC . . . . .	59
Viewing serviceable events by using the HMC. . . . .	59
Verifying the installed part by using the SDMC . . . . .	60
Activating and deactivating LEDs by using the SDMC . . . . .	61
Deactivating a system attention LED or partition LED by using the SDMC . . . . .	61
Activating or deactivating an identify LED by using the SDMC . . . . .	61
Viewing serviceable events by using the SDMC . . . . .	62
Verifying an installed part or replaced part on a system or logical partition by using Virtual I/O Server tools . . . . .	62
Verifying the installed part by using VIOS . . . . .	62
Verify the replacement part by using VIOS . . . . .	62
<b>Notices . . . . .</b>	<b>65</b>
Trademarks . . . . .	66
Electronic emission notices . . . . .	66
Class A Notices . . . . .	66
Terms and conditions . . . . .	70

---

## Safety notices

Safety notices may be printed throughout this guide:

- **DANGER** notices call attention to a situation that is potentially lethal or extremely hazardous to people.
- **CAUTION** notices call attention to a situation that is potentially hazardous to people because of some existing condition.
- **Attention** notices call attention to the possibility of damage to a program, device, system, or data.

### World Trade safety information

Several countries require the safety information contained in product publications to be presented in their national languages. If this requirement applies to your country, safety information documentation is included in the publications package (such as in printed documentation, on DVD, or as part of the product) shipped with the product. The documentation contains the safety information in your national language with references to the U.S. English source. Before using a U.S. English publication to install, operate, or service this product, you must first become familiar with the related safety information documentation. You should also refer to the safety information documentation any time you do not clearly understand any safety information in the U.S. English publications.

Replacement or additional copies of safety information documentation can be obtained by calling the IBM Hotline at 1-800-300-8751.

### German safety information

Das Produkt ist nicht für den Einsatz an Bildschirmarbeitsplätzen im Sinne § 2 der Bildschirmarbeitsverordnung geeignet.

### Laser safety information

IBM® servers can use I/O cards or features that are fiber-optic based and that utilize lasers or LEDs.

#### Laser compliance

IBM servers may be installed inside or outside of an IT equipment rack.

## DANGER

When working on or around the system, observe the following precautions:

Electrical voltage and current from power, telephone, and communication cables are hazardous. To avoid a shock hazard:

- Connect power to this unit only with the IBM provided power cord. Do not use the IBM provided power cord for any other product.
- Do not open or service any power supply assembly.
- Do not connect or disconnect any cables or perform installation, maintenance, or reconfiguration of this product during an electrical storm.
- The product might be equipped with multiple power cords. To remove all hazardous voltages, disconnect all power cords.
- Connect all power cords to a properly wired and grounded electrical outlet. Ensure that the outlet supplies proper voltage and phase rotation according to the system rating plate.
- Connect any equipment that will be attached to this product to properly wired outlets.
- When possible, use one hand only to connect or disconnect signal cables.
- Never turn on any equipment when there is evidence of fire, water, or structural damage.
- Disconnect the attached power cords, telecommunications systems, networks, and modems before you open the device covers, unless instructed otherwise in the installation and configuration procedures.
- Connect and disconnect cables as described in the following procedures when installing, moving, or opening covers on this product or attached devices.

To Disconnect:

1. Turn off everything (unless instructed otherwise).
2. Remove the power cords from the outlets.
3. Remove the signal cables from the connectors.
4. Remove all cables from the devices.

To Connect:

1. Turn off everything (unless instructed otherwise).
2. Attach all cables to the devices.
3. Attach the signal cables to the connectors.
4. Attach the power cords to the outlets.
5. Turn on the devices.

(D005)

## DANGER

Observe the following precautions when working on or around your IT rack system:

- Heavy equipment—personal injury or equipment damage might result if mishandled.
- Always lower the leveling pads on the rack cabinet.
- Always install stabilizer brackets on the rack cabinet.
- To avoid hazardous conditions due to uneven mechanical loading, always install the heaviest devices in the bottom of the rack cabinet. Always install servers and optional devices starting from the bottom of the rack cabinet.
- Rack-mounted devices are not to be used as shelves or work spaces. Do not place objects on top of rack-mounted devices.



- Each rack cabinet might have more than one power cord. Be sure to disconnect all power cords in the rack cabinet when directed to disconnect power during servicing.
- Connect all devices installed in a rack cabinet to power devices installed in the same rack cabinet. Do not plug a power cord from a device installed in one rack cabinet into a power device installed in a different rack cabinet.
- An electrical outlet that is not correctly wired could place hazardous voltage on the metal parts of the system or the devices that attach to the system. It is the responsibility of the customer to ensure that the outlet is correctly wired and grounded to prevent an electrical shock.

#### CAUTION

- Do not install a unit in a rack where the internal rack ambient temperatures will exceed the manufacturer's recommended ambient temperature for all your rack-mounted devices.
- Do not install a unit in a rack where the air flow is compromised. Ensure that air flow is not blocked or reduced on any side, front, or back of a unit used for air flow through the unit.
- Consideration should be given to the connection of the equipment to the supply circuit so that overloading of the circuits does not compromise the supply wiring or overcurrent protection. To provide the correct power connection to a rack, refer to the rating labels located on the equipment in the rack to determine the total power requirement of the supply circuit.
- *(For sliding drawers.)* Do not pull out or install any drawer or feature if the rack stabilizer brackets are not attached to the rack. Do not pull out more than one drawer at a time. The rack might become unstable if you pull out more than one drawer at a time.
- *(For fixed drawers.)* This drawer is a fixed drawer and must not be moved for servicing unless specified by the manufacturer. Attempting to move the drawer partially or completely out of the rack might cause the rack to become unstable or cause the drawer to fall out of the rack.

(R001)

**CAUTION:**

Removing components from the upper positions in the rack cabinet improves rack stability during relocation. Follow these general guidelines whenever you relocate a populated rack cabinet within a room or building:

- Reduce the weight of the rack cabinet by removing equipment starting at the top of the rack cabinet. When possible, restore the rack cabinet to the configuration of the rack cabinet as you received it. If this configuration is not known, you must observe the following precautions:
  - Remove all devices in the 32U position and above.
  - Ensure that the heaviest devices are installed in the bottom of the rack cabinet.
  - Ensure that there are no empty U-levels between devices installed in the rack cabinet below the 32U level.
- If the rack cabinet you are relocating is part of a suite of rack cabinets, detach the rack cabinet from the suite.
- Inspect the route that you plan to take to eliminate potential hazards.
- Verify that the route that you choose can support the weight of the loaded rack cabinet. Refer to the documentation that comes with your rack cabinet for the weight of a loaded rack cabinet.
- Verify that all door openings are at least 760 x 230 mm (30 x 80 in.).
- Ensure that all devices, shelves, drawers, doors, and cables are secure.
- Ensure that the four leveling pads are raised to their highest position.
- Ensure that there is no stabilizer bracket installed on the rack cabinet during movement.
- Do not use a ramp inclined at more than 10 degrees.
- When the rack cabinet is in the new location, complete the following steps:
  - Lower the four leveling pads.
  - Install stabilizer brackets on the rack cabinet.
  - If you removed any devices from the rack cabinet, repopulate the rack cabinet from the lowest position to the highest position.
- If a long-distance relocation is required, restore the rack cabinet to the configuration of the rack cabinet as you received it. Pack the rack cabinet in the original packaging material, or equivalent. Also lower the leveling pads to raise the casters off of the pallet and bolt the rack cabinet to the pallet.

(R002)

(L001)



(L002)



(L003)



or



All lasers are certified in the U.S. to conform to the requirements of DHHS 21 CFR Subchapter J for class 1 laser products. Outside the U.S., they are certified to be in compliance with IEC 60825 as a class 1 laser product. Consult the label on each part for laser certification numbers and approval information.

**CAUTION:**

This product might contain one or more of the following devices: CD-ROM drive, DVD-ROM drive, DVD-RAM drive, or laser module, which are Class 1 laser products. Note the following information:

- Do not remove the covers. Removing the covers of the laser product could result in exposure to hazardous laser radiation. There are no serviceable parts inside the device.
- Use of the controls or adjustments or performance of procedures other than those specified herein might result in hazardous radiation exposure.

(C026)

**CAUTION:**

Data processing environments can contain equipment transmitting on system links with laser modules that operate at greater than Class 1 power levels. For this reason, never look into the end of an optical fiber cable or open receptacle. (C027)

**CAUTION:**

This product contains a Class 1M laser. Do not view directly with optical instruments. (C028)

**CAUTION:**

Some laser products contain an embedded Class 3A or Class 3B laser diode. Note the following information: laser radiation when open. Do not stare into the beam, do not view directly with optical instruments, and avoid direct exposure to the beam. (C030)

**CAUTION:**

The battery contains lithium. To avoid possible explosion, do not burn or charge the battery.

*Do Not:*

- \_\_\_ Throw or immerse into water
- \_\_\_ Heat to more than 100°C (212°F)
- \_\_\_ Repair or disassemble

Exchange only with the IBM-approved part. Recycle or discard the battery as instructed by local regulations. In the United States, IBM has a process for the collection of this battery. For information, call 1-800-426-4333. Have the IBM part number for the battery unit available when you call. (C003)

## **Power and cabling information for NEBS (Network Equipment-Building System) GR-1089-CORE**

The following comments apply to the IBM servers that have been designated as conforming to NEBS (Network Equipment-Building System) GR-1089-CORE:

The equipment is suitable for installation in the following:

- Network telecommunications facilities
- Locations where the NEC (National Electrical Code) applies

The intrabuilding ports of this equipment are suitable for connection to intrabuilding or unexposed wiring or cabling only. The intrabuilding ports of this equipment *must not* be metallically connected to the interfaces that connect to the OSP (outside plant) or its wiring. These interfaces are designed for use as intrabuilding interfaces only (Type 2 or Type 4 ports as described in GR-1089-CORE) and require isolation from the exposed OSP cabling. The addition of primary protectors is not sufficient protection to connect these interfaces metallically to OSP wiring.

**Note:** All Ethernet cables must be shielded and grounded at both ends.

The ac-powered system does not require the use of an external surge protection device (SPD).

The dc-powered system employs an isolated DC return (DC-I) design. The DC battery return terminal *shall not* be connected to the chassis or frame ground.



---

## SAS RAID enablement

You might need to configure redundant array of independent disks (RAID) on your serial-attached SCSI (SAS) disk drives in your system enclosure. Use these instructions to install features to enable RAID on your system.

The following instructions will enable you to install SAS RAID Enablement cards to prepare your system to use SAS disk drives in a RAID configuration.

To find information on installing adapters or configuring RAID on your system see the following links:

- To view the PDF file of PCI adapters, approximately 40 MB in size, see <http://publib.boulder.ibm.com/infocenter/systems/scope/hw/topic/p7hak/p7hak.pdf>
- To view the PDF file of SAS RAID controllers for Linux, approximately 2 MB in size, see <http://publib.boulder.ibm.com/infocenter/systems/scope/hw/topic/p7ebk/p7ebk.pdf>
- To view the PDF file of SAS RAID controllers for AIX®, approximately 2 MB in size, see <http://publib.boulder.ibm.com/infocenter/systems/scope/hw/topic/p7ebj/p7ebj.pdf>
- To view the PDF file of SAS RAID controllers for IBM i, approximately 2 MB in size, see <http://publib.boulder.ibm.com/infocenter/systems/scope/hw/topic/p7ed5/p7ed5.pdf>
- IBM i Information Center website at <http://www.ibm.com/systems/i/infocenter>



---

## What's new in SAS RAID enablement

Read about new or significantly changed information in SAS RAID enablement since the previous update of this topic collection.

### February 2010

- Added information for IBM Power Systems™ servers that contain the POWER7® processor.



---

## RAID enablement card and auxiliary cache card in a model 8233-E8B

Installing these features will allow you to set up Redundant Array of Independent Disks (RAID) protection for your system.

The SAS RAID Enablement feature code 5679 consists of two separate adapters. The SAS RAID Enablement card and the SAS Auxiliary Cache card. These cards must always be installed together for this feature.

Replacing this feature is a customer task. You can perform this task yourself, or contact an authorized service provider to perform the task for you. You might be charged a fee by the authorized service provider for this service.

---

### Installing the model 8233-E8B Redundant Array of Independent Disks enablement card

You might need to install a Redundant Array of Independent Disks (RAID) enablement card in the server. Use the procedure in this section to perform this task.

**Attention:** You must disconnect the power source from the system by disconnecting all power cords to prevent system damage during this procedure.

#### Preparing the system

You might need to prepare your system before you install the RAID enablement card. Use the procedure in this section to perform this task.

To prepare the system for the installation of a RAID enablement card, perform the following steps:

1. Perform prerequisite tasks as described in “Before you begin” on page 27.
2. Stop the system. For instructions, see “Stopping a system or logical partition” on page 41.
3. Disconnect the power source from the system by unplugging the system.

**Attention:** You must disconnect the power source from the system by disconnecting all power cords to prevent system damage during this procedure.

**Note:** This system is equipped with a second power supply. Before continuing with this procedure, ensure that all power sources to the system have been completely disconnected.

(L003)

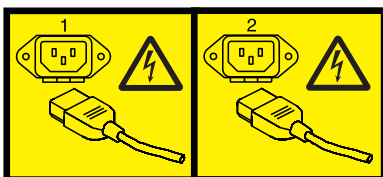

or



4. Place the system in the service position. See “Placing the 8233-E8B or 8236-E8C in the service position” on page 49.
5. Remove the access cover. See “Removing the service access cover from an 8233-E8B or 8236-E8C system” on page 46
6. Attach the wrist strap

**Attention:**

- Attach a wrist strap to an unpainted metal surface of your hardware to prevent electrostatic discharge (ESD) from damaging your hardware.
- When using a wrist strap, follow all electrical safety procedures. A wrist strap is for static control. It does not increase or decrease your risk of receiving electric shock when using or working on electrical equipment.
- If you do not have a wrist strap, just prior to removing the product from ESD packaging and installing or replacing hardware, touch an unpainted metal surface of the system for a minimum of 5 seconds.

## Installing the RAID enablement card

You will need to install the RAID enablement card to support RAID protection on your system. Use this procedure to install a RAID enablement card.

To install a RAID enablement card, perform the following steps:

1. Locate the RAID enablement card slot (P1-C11). Remove the filler if present.

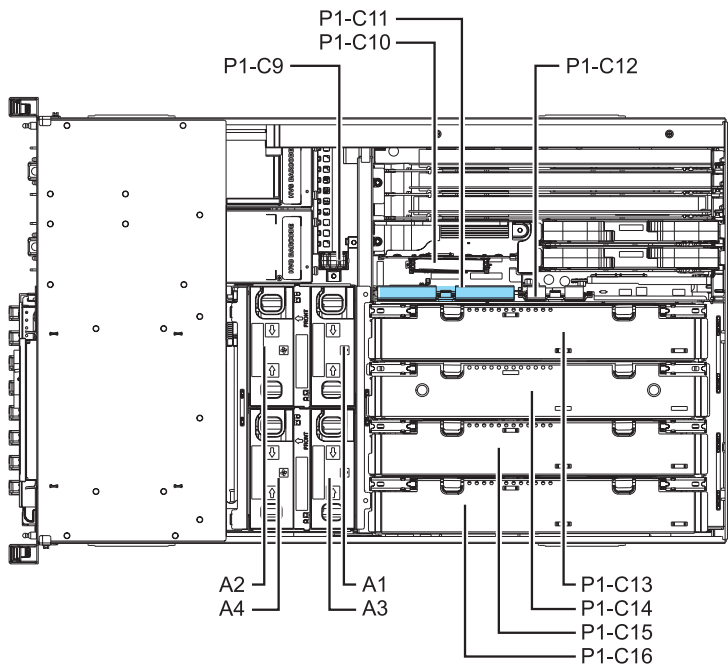

Figure 1. Slot location for RAID enablement card installation

2. Align the RAID enablement card with the slot in the system. The RAID enablement card has a metal plate **(B)** attached to it as shown in the following figures.
3. Slide the RAID enablement card into the system until the tab **(A)** locks into place as shown in the following figures.

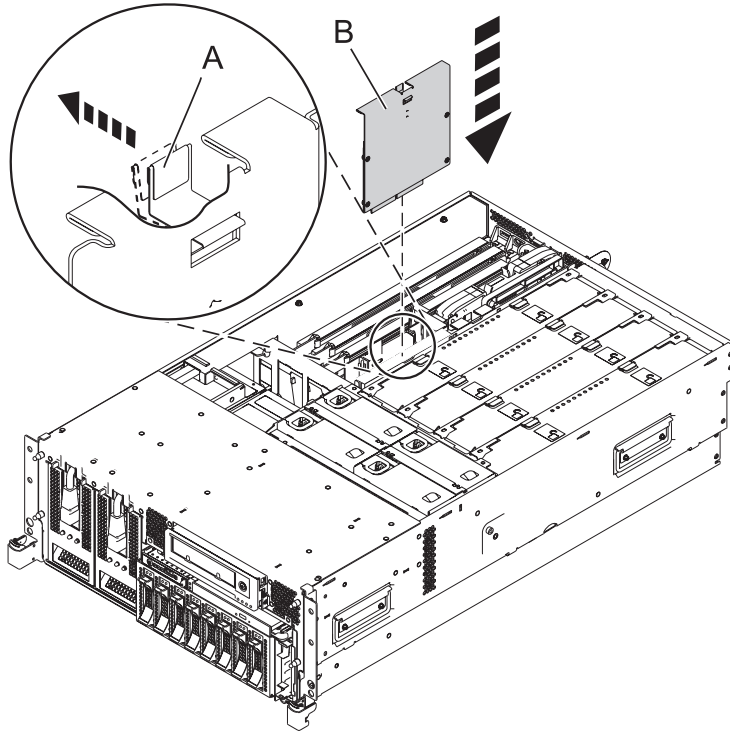

Figure 2. Rack-mounted model RAID enablement card replacement

4. Replace the service access cover. See “Installing the service access cover on an 8233-E8B or 8236-E8C system” on page 47
5. Place the system in the operating position. See “Placing the 8233-E8B or 8236-E8C in the operating position” on page 51.
6. Start the system. For instructions, see “Starting the system or logical partition” on page 37.
7. Verify that the new resource is functional. For instructions, see “Verifying the installed part” on page 53.

---

## Installing the model 8233-E8B auxiliary cache card

You might need to install an auxiliary cache card in the server. Use the procedure in this section to perform this task.

**Attention:** You must disconnect the power source from the system by disconnecting all power cords to prevent system damage during this procedure.

### Preparing the system

You might need to prepare your system before you install the auxiliary cache card. Use the procedure in this section to perform this task.

To prepare the system for the installation of an auxiliary cache card, perform the following steps:

1. Perform prerequisite tasks as described in “Before you begin” on page 27.
2. Stop the system. For instructions, see “Stopping a system or logical partition” on page 41.
3. Disconnect the power source from the system by unplugging the system.

**Attention:** You must disconnect the power source from the system by disconnecting all power cords to prevent system damage during this procedure.



**Note:** This system might be equipped with a second power supply. Before continuing with this procedure, ensure that all power sources to the system have been completely disconnected.

(L003)

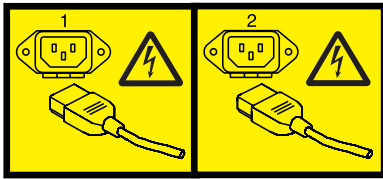

or



4. Place the system in the service position. See “Placing the 8233-E8B or 8236-E8C in the service position” on page 49.
5. Remove the access cover. See “Removing the service access cover from an 8233-E8B or 8236-E8C system” on page 46.
6. Attach the wrist strap

**Attention:**

- Attach a wrist strap to an unpainted metal surface of your hardware to prevent electrostatic discharge (ESD) from damaging your hardware.
- When using a wrist strap, follow all electrical safety procedures. A wrist strap is for static control. It does not increase or decrease your risk of receiving electric shock when using or working on electrical equipment.
- If you do not have a wrist strap, just prior to removing the product from ESD packaging and installing or replacing hardware, touch an unpainted metal surface of the system for a minimum of 5 seconds.

## Installing the auxiliary cache card

You might need to install an auxiliary cache card. Use this procedure to install an auxiliary cache card.

To install an auxiliary cache card, perform the following steps:

1. Locate the auxiliary cache card slot (P1-C10). Remove the filler if present.

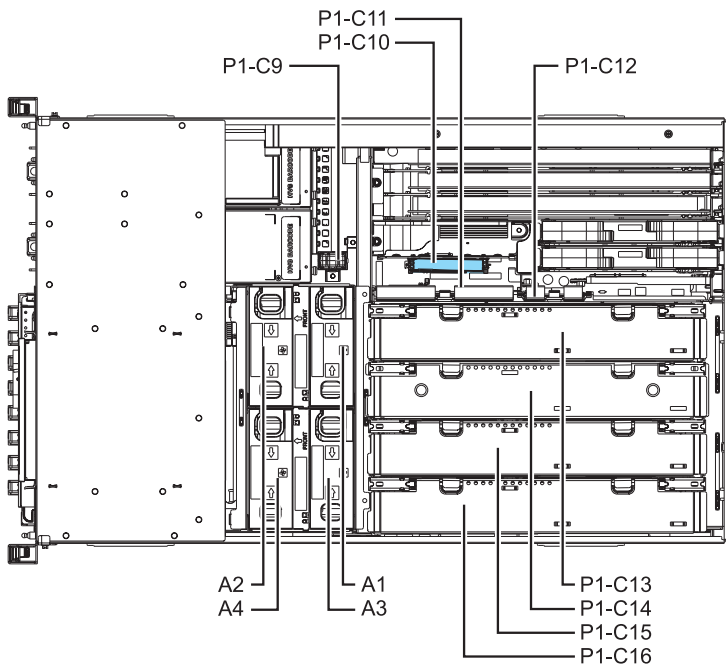

Figure 3. Slot location for the auxiliary cache card installation

2. Align the auxiliary cache card with the slot in the system.
3. Slide the auxiliary cache card (**A**) fully into the system until the tab (**B**) locks into place, as shown in the following figures. If you will also be installing the SAS RAID enablement card, refer to the "Installing the RAID enablement card" on page 6 section now.

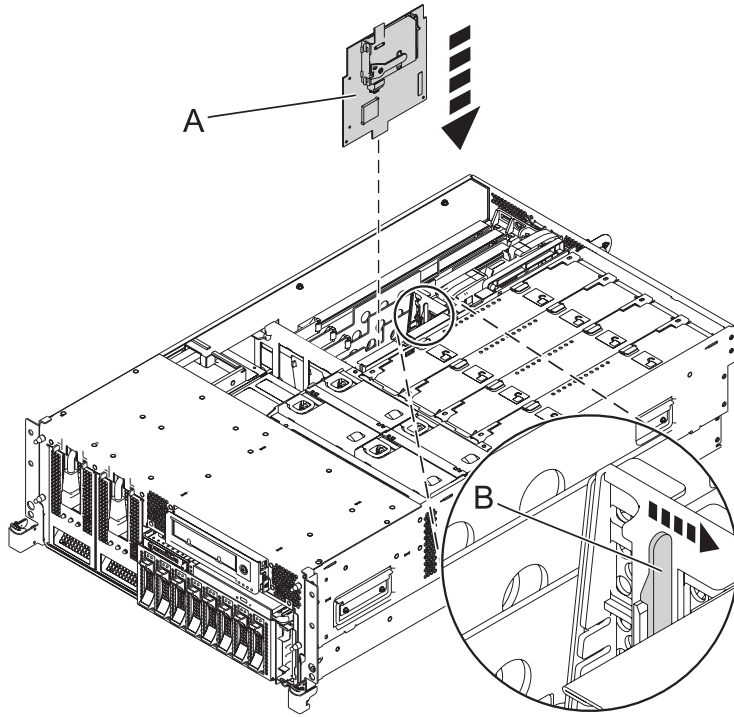

Figure 4. Rack-mounted model - RAID auxiliary cache card replacement

4. Replace the service access cover. See “Installing the service access cover on an 8233-E8B or 8236-E8C system” on page 47.
5. Place the system in the operating position. See “Placing the 8233-E8B or 8236-E8C in the operating position” on page 51.
6. Start the system. For instructions, see “Starting the system or logical partition” on page 37.
7. Verify that the new resource is functional. For instructions, see “Verifying the installed part” on page 53.

---

## Removing the model 8233-E8B auxiliary cache card

You might need to remove an auxiliary cache card from the server. Use the procedure in this section to perform this task.

**Attention:** You must disconnect the power source from the system by disconnecting all power cords to prevent system damage during this procedure.

### Preparing the system

You might need to prepare your server for removal of the auxiliary cache card. Use the procedure in this section to perform this task.

To prepare the system for the removal of a auxiliary cache card, perform the following steps:

1. Perform prerequisite tasks as described in “Before you begin” on page 27.
2. Identify the auxiliary cache card that you need to remove. For instructions, see “Identifying a part” on page 31.
3. Stop the system. For instructions, see “Stopping a system or logical partition” on page 41.
4. Disconnect the power source from the system by unplugging the system.

**Attention:** You must disconnect the power source from the system by disconnecting all power cords to prevent system damage during this procedure.

**Note:** This system might be equipped with a second power supply. Before continuing with this procedure, ensure that all power sources to the system have been completely disconnected.

(L003)

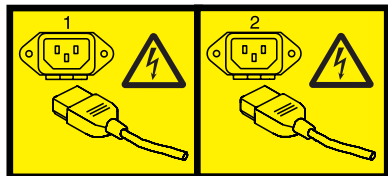

or



5. Place the system in the service position. See “Placing the 8233-E8B or 8236-E8C in the service position” on page 49.
6. Remove the access cover. See “Removing the service access cover from an 8233-E8B or 8236-E8C system” on page 46
7. Attach the wrist strap

**Attention:**

- Attach a wrist strap to an unpainted metal surface of your hardware to prevent electrostatic discharge (ESD) from damaging your hardware.
- When using a wrist strap, follow all electrical safety procedures. A wrist strap is for static control. It does not increase or decrease your risk of receiving electric shock when using or working on electrical equipment.
- If you do not have a wrist strap, just prior to removing the product from ESD packaging and installing or replacing hardware, touch an unpainted metal surface of the system for a minimum of 5 seconds.

## Removing the auxiliary cache card

You might need to remove the auxiliary cache card from your server. Use the procedure in this section to perform this task.

To remove an auxiliary cache card, perform the following steps:

1. Press the tab (A) and lift the cache card (B) up and out of the system, as shown in the following figure.

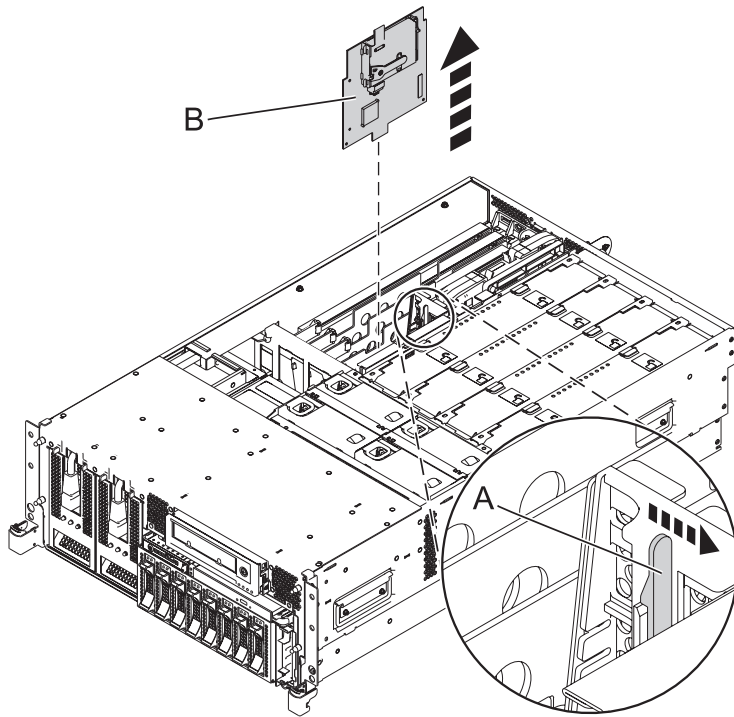

Figure 5. RAID cache card removal from a rack-mounted system unit

2. Replace the RAID enablement card. For instructions, see “Replacing the model 8233-E8B auxiliary cache card.”

---

## Replacing the model 8233-E8B auxiliary cache card

If you removed the auxiliary cache card as a part of another procedure, you might need to replace the card. Use the procedure in this section to perform this task.

You must have already completed the procedure “Removing the model 8233-E8B auxiliary cache card” on page 11.

To replace an auxiliary cache card, complete the following steps:

1. Align the auxiliary cache card with the slot in the system.

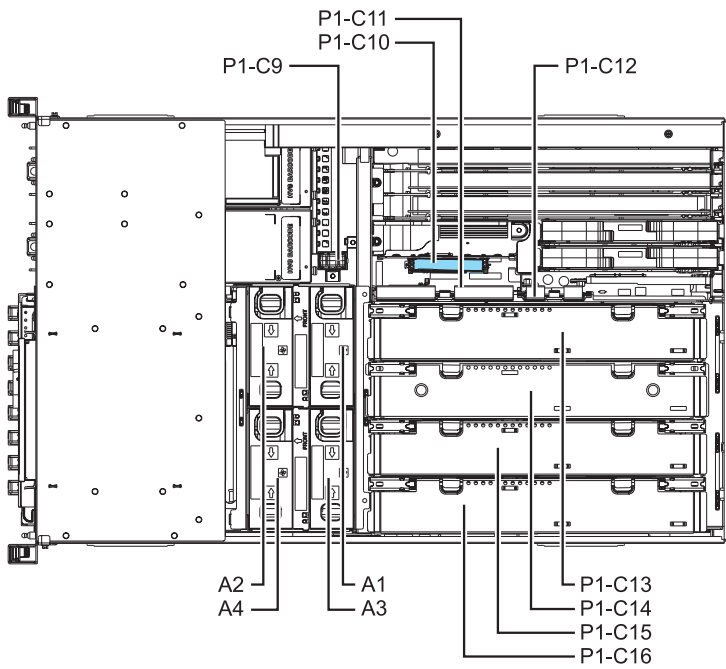

Figure 6. Slot location for the RAID auxiliary cache card

- Slide the auxiliary cache card(A) into the system until the tab (B) locks into place.

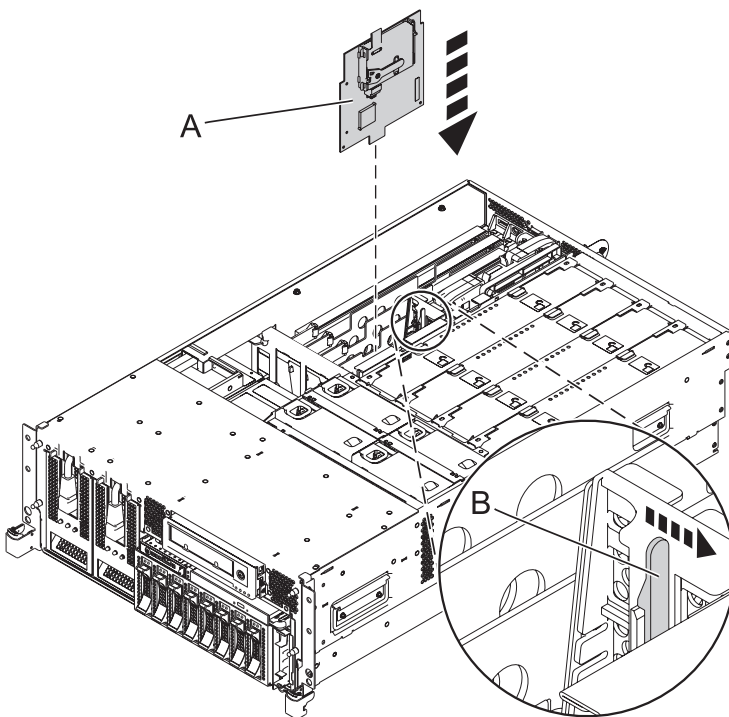

Figure 7. Rack-mounted RAID auxiliary cache card replacement

3. Replace the service access cover. See “Installing the service access cover on an 8233-E8B or 8236-E8C system” on page 47
4. Place the system in the operating position. See “Placing the 8233-E8B or 8236-E8C in the operating position” on page 51.
5. Start the system. For instructions, see “Starting the system or logical partition” on page 37.
6. Verify that the new resource is functional. For instructions, see “Verifying the installed part” on page 53.

---

## Removing the model 8233-E8B Redundant Array of Independent Disks enablement card

You might need to remove a Redundant Array of Independent Disks (RAID) enablement card from the server. Use the procedure in this section to perform this task.

**Attention:** You must disconnect the power source from the system by disconnecting all power cords to prevent system damage during this procedure.

### Preparing the system

You might need to prepare your server for removal of the RAID enablement card. Use the procedure in this section to perform this task.

To prepare the system for the removal of a RAID enablement card, perform the following steps:

1. Perform prerequisite tasks as described in “Before you begin” on page 27.
2. Identify the auxiliary cache card that you need to remove. For instructions, see “Identifying a part” on page 31.
3. Stop the system. For instructions, see “Stopping a system or logical partition” on page 41.
4. Disconnect the power source from the system by unplugging the system.

**Attention:** You must disconnect the power source from the system by disconnecting all power cords to prevent system damage during this procedure.

**Note:** This system might be equipped with a second power supply. Before continuing with this procedure, ensure that all power sources to the system have been completely disconnected.

(L003)

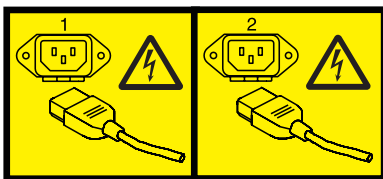

or



5. If you have a rack-mounted system, place it in the service position. See “Placing the 8233-E8B or 8236-E8C in the service position” on page 49.
6. Remove the access cover. See “Removing the service access cover from an 8233-E8B or 8236-E8C system” on page 46.
7. Attach the wrist strap

**Attention:**

- Attach a wrist strap to an unpainted metal surface of your hardware to prevent electrostatic discharge (ESD) from damaging your hardware.
- When using a wrist strap, follow all electrical safety procedures. A wrist strap is for static control. It does not increase or decrease your risk of receiving electric shock when using or working on electrical equipment.
- If you do not have a wrist strap, just prior to removing the product from ESD packaging and installing or replacing hardware, touch an unpainted metal surface of the system for a minimum of 5 seconds.

## Removing the RAID enablement card

You might need to remove the RAID enablement card from your server. Use the procedure in this section to perform this task.

To remove a RAID enablement card, perform the following steps:

1. Locate the RAID enablement card you want to remove.
2. Press the tab **(B)** and slide the card out of the system as shown in the following figures. The RAID enablement card is attached to a metal plate **(A)**. You will slide the metal plate out of the system to remove the RAID enablement card.



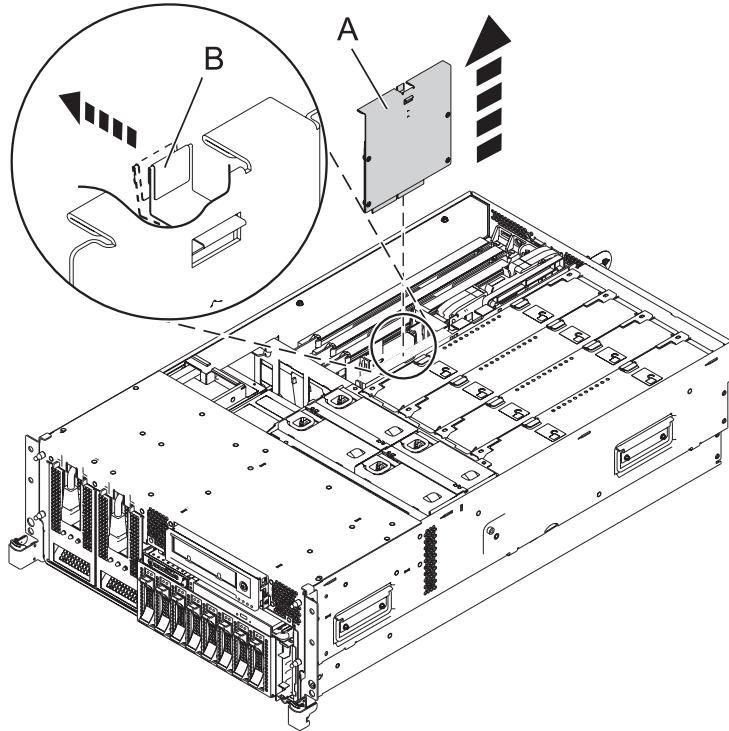

Figure 8. RAID enablement card removal from a rack-mounted system unit

3. Replace the RAID enablement card. For instructions, see “Replacing the model 8233-E8B Redundant Array of Independent Disks enablement card.”

---

## Replacing the model 8233-E8B Redundant Array of Independent Disks enablement card

If you removed the Redundant Array of Independent Disks (RAID) enablement card as a part of another procedure, you might need to replace the card. Use the procedure in this section to perform this task.

You must have already completed the procedure “Removing the model 8233-E8B Redundant Array of Independent Disks enablement card” on page 15.

To replace a RAID enablement card, complete the following steps:

1. Locate the slot for the RAID enablement card

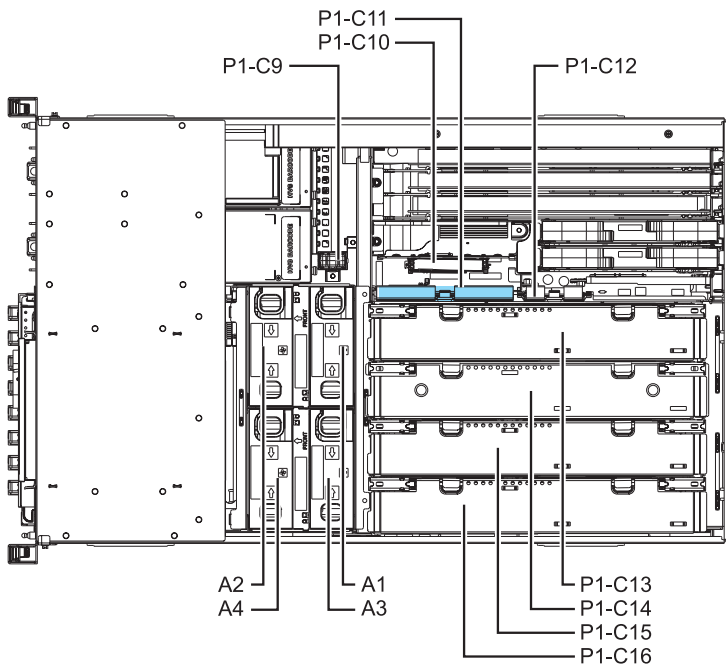

Figure 9. Slot location for the RAID enablement card installation

2. Align the RAID enablement card with the slot in the system.
3. Slide the RAID enablement card fully into the system until the tab (A) locks into place.

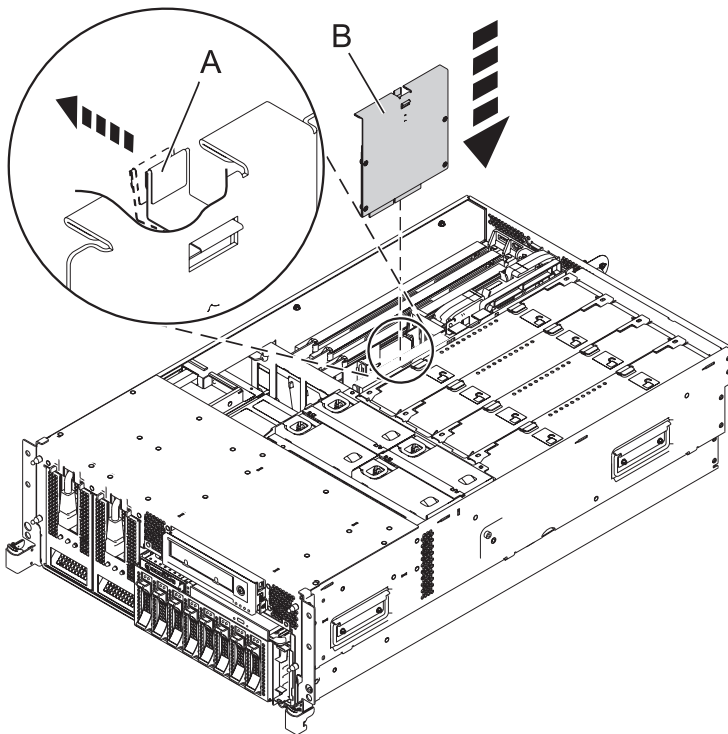

Figure 10. RAID enablement card replacement in a rack-mounted system unit

4. Replace the service access cover. See “Installing the service access cover on an 8233-E8B or 8236-E8C system” on page 47
5. Place the system in the operating position. See “Placing the 8233-E8B or 8236-E8C in the operating position” on page 51.
6. Start the system. For instructions, see “Starting the system or logical partition” on page 37.
7. If you replaced the RAID enablement card as part of another procedure, return to that procedure now. If you replaced the RAID enablement card because it was not operational, verify that the new resource is functional. For instructions, see “Verifying the installed part” on page 53.

---

## Managing the cache battery pack

You might need to remove or replace the cache battery from its controller. This section includes procedures so that you can perform these tasks.

**Note:** Replacing this feature is a customer task. You can perform this task yourself, or contact an authorized service provider to perform the task for you. You might be charged a fee by the authorized service provider for this service.

## Removing and installing the cache battery pack

To service the cache battery pack, complete the following procedure:

1. Begin with power on.  
To prevent data loss, the cache battery pack must be in an error state before it is removed from the system.  
If you have powered the system off, power it on before you continue.
  2. Select your operating system:
    - AIX: Go to step 3
    - Linux: Go to step 5
    - IBM i: Go to step 7
  3. Force the cache battery pack into an error state on AIX (to prevent possible data loss), as follows:
    - a. Navigate to the IBM SAS Disk Array Manager by using the following steps:
      - 1) At the command prompt, type `smit`, and press Enter.
      - 2) Select **Devices**.
      - 3) Select **Disk Array**.
      - 4) Select **IBM SAS Disk Array**.
      - 5) Select **IBM SAS Disk Array Manager** from the menu with options for configuring and managing the IBM SAS RAID Controller.
    - b. Select **Diagnostics and Recovery Options**.
    - c. Select **Controller Rechargeable Battery Maintenance**.
    - d. Select **Force Controller Rechargeable Battery Error**.
    - e. Select the **IBM SAS RAID Controller** whose battery you want to replace.
    - f. This option places the battery into the error state, which requires it to be replaced.
    - g. Determine that it is safe to replace the cache battery pack. See the following Displaying Rechargeable Battery Information procedure. It is safe to replace the cache battery pack when **Yes** is displayed next to **Battery pack can be safely replaced**. You might need to reselect the option **Display Controller Rechargeable Battery Information** multiple times as it might take several minutes before it is safe to replace the cache battery pack.
    - h. Verify that the Cache Present LED is not flashing.
- Displaying Rechargeable Battery Information
- a. Navigate to the **IBM SAS Disk Array Manager** by using the previous procedure.

- b. Select **Diagnostics and Recovery Options**.
  - c. Select **Controller Rechargeable Battery Maintenance**.
  - d. Select **Display Controller Rechargeable Battery Information**.
  - e. Select **IBM SAS RAID Controller**.
4. Go to step 8.
  5. Force the cache battery pack into an error state on Linux (to prevent possible data loss), as follows:
    - a. Run the iprconfig utility by typing iprconfig.
    - b. Select **Work with disk unit recovery**.
    - c. Select **Work with resources containing cache battery packs**.
    - d. Select your adapter and type 2. Then press Enter to force the battery error.
 

**Note:** This option places the battery into the error state, which requires it to be replaced.
    - e. If you are sure you want to force a battery error, type c to confirm. If you do not want to force a battery error, type q to cancel.
    - f. Determine that it is safe to replace the cache battery pack. See Displaying Rechargeable Battery Information.
    - g. It is safe to replace the cache battery pack when **Yes** is displayed next to **Battery pack can be safely replaced**. You might need to reselect the option **Display Controller Rechargeable Battery Information** multiple times as it might take several minutes before it is safe to replace the cache battery pack.
  6. Go to step 8.
  7. Force the cache battery pack into an error state on IBM i (to prevent possible data loss), as follows on the system or partition that contains the adapter:
    - a. Be sure that you are signed on to the system with at least service level authority.
    - b. Type strsst on the command line and press Enter.
    - c. Type your service tools user ID and service tools password on the System Service Tools (SST) Sign On display. Press Enter.
    - d. Select **Start a Service Tool** from the System Service Tools (SST) display and press Enter.
    - e. Select **Hardware Service Manager** from the Start a Service Tool display and press Enter.
    - f. Select **Work with resources containing cache battery packs** from the Hardware Service Manager display and press Enter.
    - g. Select **Force battery pack into error state** for the I/O card that you are working with from the **Work with Resources containing cache battery packs** display and press Enter.
    - h. On the **Force Battery Packs Into Error State** display, verify that the correct I/O adapter has been selected and press the function key that confirms your choice.
    - i. Return to the Work with Resources containing cache battery packs display and select **Display battery information**. Ensure that the field **Safe to replace cache battery** is set to **Yes**. This might take several minutes and you might need to press the refresh key to see the field update.
  8. Place a rack-mounted system into service position. Go to “Placing the 8233-E8B or 8236-E8C in the service position” on page 49
  9. Remove the service access cover. Go to “Removing the service access cover from an 8233-E8B or 8236-E8C system” on page 46
  10. Check cache battery LED by examining the LED on the cache battery pack (C).

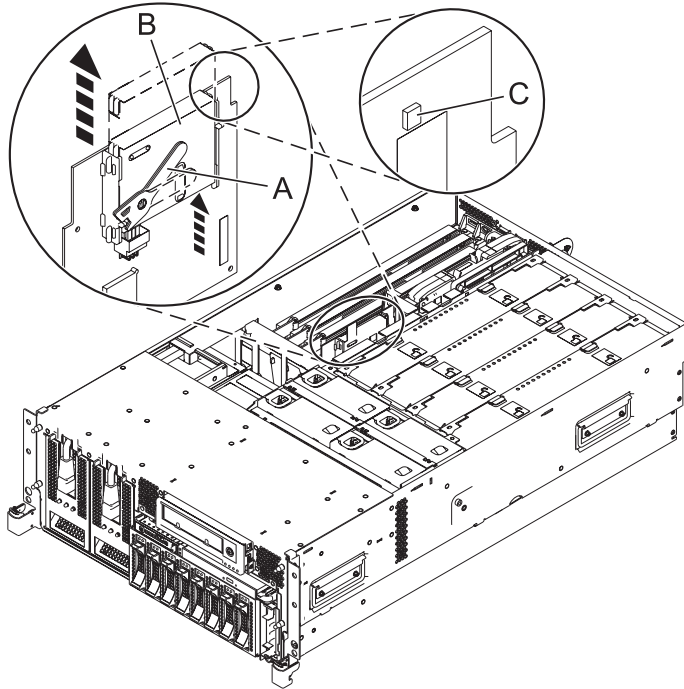

**Is the cache battery LED flashing?**

Yes, the LED is flashing

↓

No, the LED is not flashing.

Go to step 12.

**11. Stop removing the cache battery pack**

The flashing LED indicates that there is cached data on the battery that has not been saved. This data will be lost if the battery is removed at this time. Complete this service procedure without replacing the battery, and then retry it to ensure all cache data is saved before the battery is replaced.

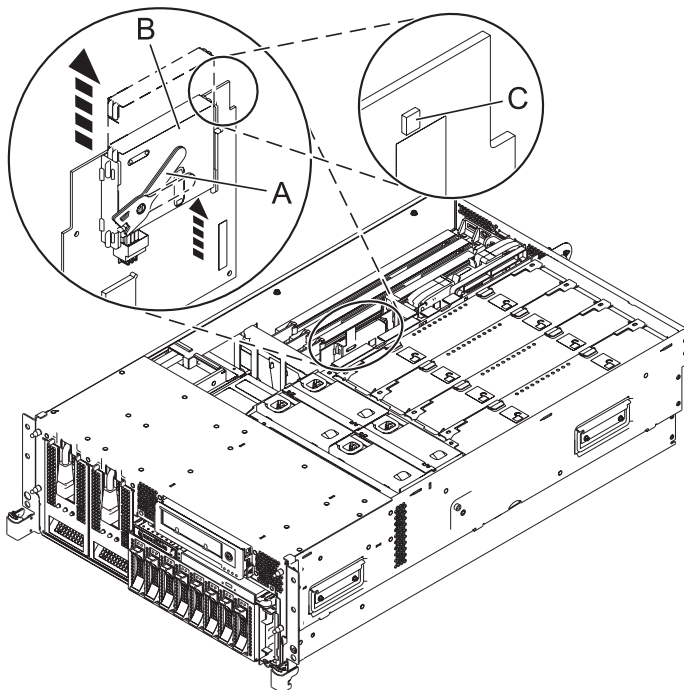

Go to step 18.

12. Remove the cache battery pack as follows:

**Attention:** Do not remove the cache battery if the LED (C) is flashing because this indicates cache data exists.

- a. While applying pressure downward on the card to ensure that it remains seated, move the cache battery lever (A) away from the connector to disengage the battery from the connector.
- b. Slide the cache battery pack (B) out of the mounting guides and remove it from the controller.

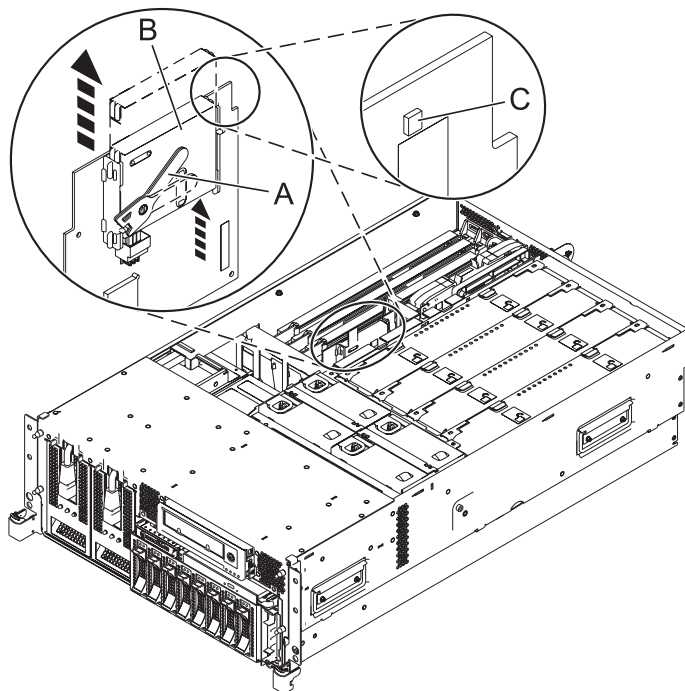

13. Install the cache battery pack as follows:

**Attention:**

Ensure that the cache battery pack is disconnected for at least 60 seconds before you connect the new battery. This is the minimum amount of time needed for the card to recognize that the battery has been replaced.

- a. Slide the cache battery pack (**B**) into the mounting guides on the controller until it is seated in the battery connector (**C**).
- b. After the battery is seated in the connector, move the lever (**A**) to the latched position to fully seat the battery into the connector.

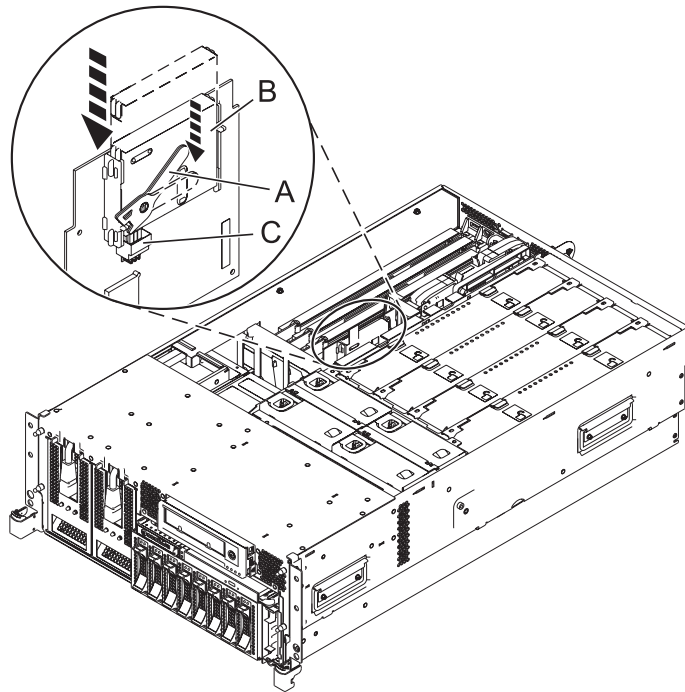

14. Restart the adapter's write cache by doing the following steps:  
Select your operating system:
  - AIX: Go to step 15
  - Linux: 16
  - IBM i: Go to step 17
15. Perform the following steps:
  - a. Navigate to the IBM SAS Disk Array Manager by using the information in step 3a.
  - b. Select **Diagnostics and Recovery Options**.
  - c. Select **Controller Rechargeable Battery Maintenance**.
  - d. Select **Start Adapter Cache**.
  - e. Select the controller with the battery you just replaced and press Enter.
  - f. Go to step 18.
16. Perform the following steps:
  - a. Run the iprconfig utility by typing iprconfig.
  - b. Select **Work with disk unit recovery**.
  - c. Select **Work with resources containing cache battery packs**.
  - d. Start the I/O adapter cache on the adapter for the battery that you just replaced by typing 3 and press Enter.

- e. Go to step 18.
17. Perform the following steps:
    - a. Return to the Work with Resources containing Cache Battery Packs display using the information in step 7a to 7f and select the **Start IOA cache**. Press Enter.
    - b. Ensure that you get the message Cache was started.
    - c. Go to step 18.
  18. Install the service access cover. Go to “Installing the service access cover on an 8233-E8B or 8236-E8C system” on page 47
  19. Place into operating position. Go to u
  20. Close the back door on the unit you are servicing.
  21. Verify that the new resource is working correctly, as described in “Verifying the installed part” on page 53.



---

## **Common procedures for installable features**

This section contains all the common procedures that are related to installing, removing, and replacing features.



---

## Before you begin

Observe these precautions when you are installing, removing, or replacing features and parts.

These precautions are intended to create a safe environment to service your system and do not provide steps for servicing your system. The installation, removal, and replacement procedures provide the step-by-step processes required to service your system.

### DANGER

When working on or around the system, observe the following precautions:

Electrical voltage and current from power, telephone, and communication cables are hazardous. To avoid a shock hazard:

- Connect power to this unit only with the IBM provided power cord. Do not use the IBM provided power cord for any other product.
- Do not open or service any power supply assembly.
- Do not connect or disconnect any cables or perform installation, maintenance, or reconfiguration of this product during an electrical storm.
- The product might be equipped with multiple power cords. To remove all hazardous voltages, disconnect all power cords.
- Connect all power cords to a properly wired and grounded electrical outlet. Ensure that the outlet supplies proper voltage and phase rotation according to the system rating plate.
- Connect any equipment that will be attached to this product to properly wired outlets.
- When possible, use one hand only to connect or disconnect signal cables.
- Never turn on any equipment when there is evidence of fire, water, or structural damage.
- Disconnect the attached power cords, telecommunications systems, networks, and modems before you open the device covers, unless instructed otherwise in the installation and configuration procedures.
- Connect and disconnect cables as described in the following procedures when installing, moving, or opening covers on this product or attached devices.

To Disconnect:

1. Turn off everything (unless instructed otherwise).
2. Remove the power cords from the outlets.
3. Remove the signal cables from the connectors.
4. Remove all cables from the devices.

To Connect:

1. Turn off everything (unless instructed otherwise).
2. Attach all cables to the devices.
3. Attach the signal cables to the connectors.
4. Attach the power cords to the outlets.
5. Turn on the devices.

(D005)

### DANGER

Observe the following precautions when working on or around your IT rack system:

- Heavy equipment—personal injury or equipment damage might result if mishandled.
- Always lower the leveling pads on the rack cabinet.
- Always install stabilizer brackets on the rack cabinet.
- To avoid hazardous conditions due to uneven mechanical loading, always install the heaviest devices in the bottom of the rack cabinet. Always install servers and optional devices starting from the bottom of the rack cabinet.
- Rack-mounted devices are not to be used as shelves or work spaces. Do not place objects on top of rack-mounted devices.



- Each rack cabinet might have more than one power cord. Be sure to disconnect all power cords in the rack cabinet when directed to disconnect power during servicing.
- Connect all devices installed in a rack cabinet to power devices installed in the same rack cabinet. Do not plug a power cord from a device installed in one rack cabinet into a power device installed in a different rack cabinet.
- An electrical outlet that is not correctly wired could place hazardous voltage on the metal parts of the system or the devices that attach to the system. It is the responsibility of the customer to ensure that the outlet is correctly wired and grounded to prevent an electrical shock.

#### CAUTION

- Do not install a unit in a rack where the internal rack ambient temperatures will exceed the manufacturer's recommended ambient temperature for all your rack-mounted devices.
- Do not install a unit in a rack where the air flow is compromised. Ensure that air flow is not blocked or reduced on any side, front, or back of a unit used for air flow through the unit.
- Consideration should be given to the connection of the equipment to the supply circuit so that overloading of the circuits does not compromise the supply wiring or overcurrent protection. To provide the correct power connection to a rack, refer to the rating labels located on the equipment in the rack to determine the total power requirement of the supply circuit.
- *(For sliding drawers.)* Do not pull out or install any drawer or feature if the rack stabilizer brackets are not attached to the rack. Do not pull out more than one drawer at a time. The rack might become unstable if you pull out more than one drawer at a time.
- *(For fixed drawers.)* This drawer is a fixed drawer and must not be moved for servicing unless specified by the manufacturer. Attempting to move the drawer partially or completely out of the rack might cause the rack to become unstable or cause the drawer to fall out of the rack.

(R001)

Before you begin a replacement or installation procedure, perform these tasks:

1. If you are installing a new feature, ensure that you have the software required to support the new feature. See IBM Prerequisite.
2. If you are performing an installation or replacement procedure that might put your data at risk, ensure, wherever possible, that you have a current backup of your system or logical partition (including operating systems, licensed programs, and data).
3. Review the installation or replacement procedure for the feature or part.
4. Note the significance of color on your system.

Blue or terra-cotta on a part of the hardware indicates a touch point where you can grip the hardware to remove it from or install it in the system, open or close a latch, and so on. Terra-cotta might also indicate that the part can be removed and replaced with the system or logical partition power on.

5. Ensure that you have access to a medium flat-blade screwdriver, a Phillips screwdriver, and a pair of scissors.
6. If parts are incorrect, missing, or visibly damaged, do the following:
  - If you are replacing a part, contact the provider of your parts or next level of support.
  - If you are installing a feature, contact one of the following service organizations:
    - The provider of your parts or next level of support.
    - In the United States, the IBM Rochester Manufacturing Automated Information Line (R-MAIL) at 1-800-300-8751.

In countries and regions outside of the United States, use the following website to locate your service and support telephone numbers:

<http://www.ibm.com/planetwide>

7. If you encounter difficulties during the installation, contact your service provider, your IBM reseller, or your next level of support.
8. If you are installing new hardware in a logical partition, you need to understand and plan for the implications of partitioning your system. For information, see Logical Partitioning.



---

## Identifying a part

Use these instructions to learn how to identify the location of a failed part, the location of a part to be removed, or the location to install a new part on your system or expansion unit using the appropriate method for your system.

For IBM Power Systems servers that contain the POWER7 processor, the light-emitting diodes (LEDs) can be used to identify or verify the location of a part that you are removing, servicing, or installing.

The combination identify and fault LED (amber color) shows the location of a field replaceable unit (FRU). When removing a FRU, first verify whether you are working on the correct FRU by using the identify function in the management console or other user interface. When removing a FRU by using the hardware management console, the identify function is activated and deactivated automatically at the correct times.

The identify function causes the amber LED to flash. When you turn off the identify function, the LED returns to the state it was previously. For parts that have a blue service button, the identify function sets LED information for the service button so that when the button is pressed, the correct LEDs on that part flash.

If you need to use the identify function, use the following procedures.

---

## Control panel LEDs

Use this information as a guide to the control panel LEDs and buttons.

The control panel has LEDs that indicate various system status.

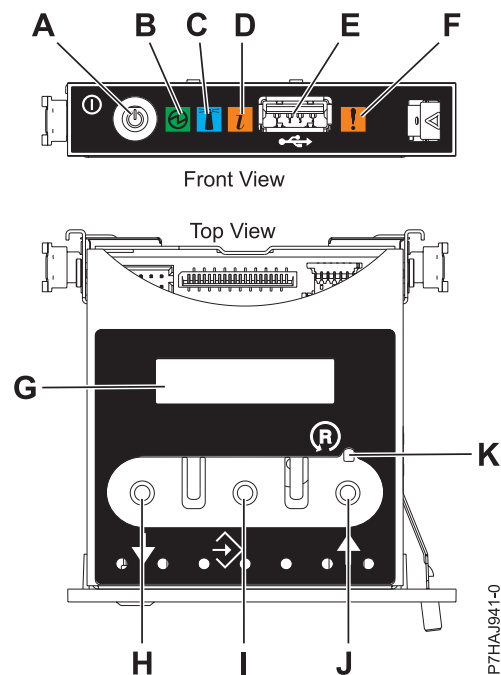

Figure 11. Control panel

- **A:** Power-on button
- **B:** Power LED
  - A constant light indicates full system power to the unit.
  - A flashing light indicates standby power to the unit.

**Note:** There is approximately a 30-second transition period from the time the power-on button is pressed to when the power LED goes from flashing to solid. During the transition period, the LED might flash faster.

- **C:** Enclosure identify light
  - A constant light indicates the identify state, which is used to identify a part.
  - No light indicates that the system is operating normally.
- **D:** System information light
  - No light indicates that the system is operating normally.
  - Light on indicates that the system requires attention.
- **E:** USB port
- **F:** Enclosure fault roll-up light
  - A constant light indicates a fault in the system unit.
  - No light indicates that the system is operating normally.
- **G:** Function/Data display
- **H:** Decrement button
- **I:** Enter button
- **J:** Increment button
- **K:** Pinhole reset button

**Related concepts:**

Identifying a failing part

Use these instructions to learn how to locate and identify a failing part on your system or expansion unit using the appropriate method for your system.

## Identifying a failing part in an AIX system or logical partition

Use these instructions to learn how to locate a failing part, and then activate the indicator light for that part on a system or logical partition running the AIX operating system.

## Locating a failing part in an AIX system or logical partition

You might need to use AIX tools, before activating the indicator light, to locate a part that is failing.

1. Log in as root user or celogin-.
2. At the command line, type `diag` and press Enter.
3. From the Function Selection menu, select **Task Selection** and press Enter.
4. Select **Display Previous Diagnostic Results** and press Enter.
5. From the Display Previous Diagnostic Results display, select **Display Diagnostic Log Summary**. The Display Diagnostic Log display shows a chronological list of events.
6. Look in the **T** column for the most recent **S** entry. Select this row in the table and press Enter.
7. Select **Commit**. The details of this log entry are shown.
8. Record the location information and the SRN value shown near the end of the entry.
9. Exit to the command line.

Use the location information for the failing part to activate the indicator light that identifies the failing part. See “Activating the indicator light for the failing part” on page 33.



## Activating the indicator light for the failing part

Use these instructions to help physically identify the location of a part you are servicing.

To activate the indicator light for a failing part, complete the following steps:

1. Log in as root user.
2. At the command line, type `diag` and press Enter.
3. From the **Function Selection** menu, select **Task Selection** and press Enter.
4. From the **Task Selection** menu, select **Identify and Attention Indicators** and press Enter.
5. From the list of lights, select the location code for the failing part and press Enter.
6. Select **Commit**. This turns on the system attention and indicator light for the failing part.
7. Exit to the command line.

## Deactivating the failing-part indicator light

Use this procedure to turn off any indicator light that you turned on as a part of a service action.

To deactivate the indicator light, complete the following steps:

1. Log in as root user.
2. At the command line, type `diag` and press Enter.
3. From the **Function Selection** menu, select **Task Selection** and press Enter.
4. From the **Task Selection** menu, select **Identify and Attention Indicators** and press Enter.
5. From the list of lights, select the location code for the failing part and press Enter. When a light is activated for a failing part, an I character precedes the location code.
6. Select **Commit**. This turns off the system attention and indicator light for the failing part.
7. Exit to the command line.

---

## Identifying a failing part in an IBM i system or logical partition

You can activate or deactivate the indicator light by using IBM i to assist in locating a failing part.

### Activating the failing-part indicator light

You can search the service action log for an entry that matches the time, reference code, or resource of a problem, and then activate the indicator light for a failing part.

1. Sign on to an IBM i session, **with at least service level authority**.
2. On the command line of the session, type `strsst` and press Enter.

**Note:** If you cannot get to the System Service Tools display, use function 21 from the control panel. Alternatively, if the system is managed by a Hardware Management Console (HMC), use the Service Focal Point™ utilities to get to the Dedicated Service Tools (DST) display.

3. Type your service tools user ID and service tools password on the System Service Tools (SST) Sign On display and press Enter.

**Remember:** The service tools password is case-sensitive.

4. Select **Start a service tool** from the System Service Tools (SST) display and press Enter.
5. Select **Hardware service manager** from the Start a Service Tool display and press Enter.
6. Select **Work with service action log** from the Hardware Service Manager display and press Enter.
7. On the Select Timeframe display, change the **From: Date and Time** field to a date and time prior to when the problem occurred.
8. Search for an entry that matches one or more conditions of the problem:
  - System reference code

- Resource
  - Date and time
  - Failing item list
9. Select option 2 (Display failing item information) to display the service action log entry.
  10. Select option 2 (Display details) to display location information for the failing part to be replaced. The information displayed in the date and time fields is the date and time for the first occurrence of the specific system reference code for the resource displayed during the time range selected.
  11. If location information is available, select option 6 (Indicator on) to turn on the failing part's indicator light.

**Tip:** If the failing part does not contain a physical indicator light, a higher-level indicator light is activated. For example, the indicator light for the backplane or unit that contains the failing part might be lit. In this case, use the location information to locate the actual failing part.

12. Look for the enclosure indicator light to locate the enclosure that contains the failing part.

## Deactivating the failing-part indicator light

Use this procedure to turn off any indicator light that you turned on as a part of a service action.

To deactivate the indicator light, follow these steps:

1. Sign on to an IBM i session, **with at least service level authority**.
2. On the command line of the session, type `strsst` and press Enter.

**Note:** If you cannot get to the System Service Tools display, use function 21 from the control panel. Alternatively, if the system is managed by a Hardware Management Console (HMC), use the Service Focal Point utilities to get to the Dedicated Service Tools (DST) display.

3. Type your service tools user ID and service tools password on the System Service Tools (SST) Sign On display and press Enter.

**Remember:** The service tools password is case-sensitive.

4. Select **Start a service tool** from the System Service Tools (SST) display and press Enter.
5. Select **Hardware service manager** from the Start a Service Tool display and press Enter.
6. Select **Work with service action log** from the Hardware Service Manager display and press Enter.
7. On the Select Timeframe display, change the **From: Date and Time** field to a date and time prior to when the problem occurred.
8. Search for an entry that matches one or more conditions of the problem:
  - System reference code
  - Resource
  - Date and time
  - Failing item list
9. Select option 2 (Display failing item information) to display the service action log entry.
10. Select option 2 (Display details) to display location information for the failing part to be replaced. The information displayed in the date and time fields is the date and time for the first occurrence of the specific system reference code for the resource displayed during the time range selected.
11. Select option 7 (Indicator off) to turn off the indicator light.
12. Select the **Acknowledge all errors** function at the bottom of the Service Action Log display, if all problems have been resolved.
13. Close the log entry by selecting option 8 (Close new entry) on the Service Action Log Report display.

---

## Identifying a failing part in a Linux system or logical partition

If the service aids have been installed on a system or logical partition, you can activate or deactivate the indicator lights to locate a part or complete a service action.

## Locating a failing part in a Linux system or logical partition

If the service aids have been installed on a system or logical partition, you need to activate the indicator lights to locate a part.

To activate the indicator light, follow these steps:

1. Log in as root user.
2. At the command line, type `/usr/sbin/usysident -s identify -l location_code` and press Enter.
3. Look for the system attention light to identify the enclosure that contains the failing part.

### Related information:

 Service and productivity tools for PowerLinux servers from IBM  
IBM provides hardware diagnostic aids and productivity tools, and installation aids for Linux operating systems on IBM Power Systems servers.

## Finding the location code of a failing part in a Linux system or logical partition

To retrieve the location code of the failing part, if you do not know the location code, use the procedure in this topic.

To locate the failing part in a system or logical partition, follow these steps:

1. Log in as root user.
2. At the command line, type `grep diagela /var/log/platform` and press Enter.
3. Look for the most recent entry that contains a system reference code (SRC).
4. Record the location information.

### Related information:

 Service and productivity tools for PowerLinux servers from IBM  
IBM provides hardware diagnostic aids and productivity tools, and installation aids for Linux operating systems on IBM Power Systems servers.

## Activating the indicator light for the failing part

If you know the location code of the failing part, activate the indicator light to help you locate which part to replace.

To activate the indicator light, follow these steps:

1. Log in as root user.
2. At the command line, type `/usr/sbin/usysident -s identify -l location_code` and press Enter.
3. Look for the system attention light to identify the enclosure that contains the failing part.

### Related information:

 Service and productivity tools for PowerLinux servers from IBM  
IBM provides hardware diagnostic aids and productivity tools, and installation aids for Linux operating systems on IBM Power Systems servers.

## Deactivating the failing-part indicator light

After you complete a removal and replacement procedure, you must deactivate the failing-part indicator light.

To deactivate the indicator light, follow these steps:

1. Log in as root user.
2. At the command line, type `/usr/sbin/usysident -s normal -l location_code` and press Enter.

**Related information:**

 Service and productivity tools for PowerLinux servers from IBM  
IBM provides hardware diagnostic aids and productivity tools, and installation aids for Linux operating systems on IBM Power Systems servers.

---

## Locating a failing part in a Virtual I/O Server system or logical partition

You can use Virtual I/O Server (VIOS) tools, before activating the indicator light, to locate a part that is failing.

To locate the failing part, follow these steps:

1. Log in as root user or `celogin-`.
2. At the command line, type `diagmenu` and press Enter.
3. From the **Function Selection** menu, select **Task Selection** and press Enter.
4. Select **Display Previous Diagnostic Results** and press Enter.
5. From the **Display Previous Diagnostic Results** display, select **Display Diagnostic Log Summary**. A **Display Diagnostic Log** display appears. This display contains a chronological list of events.
6. Look in the **T** column for the most recent **S** entry. Select this row in the table and press Enter.
7. Choose **Commit**. The details of this log entry are shown.
8. Record the location information and the SRN value shown near the end of the entry.
9. Exit to the command line.

Use the location information for the failing part to activate the indicator light that identifies the failing part. For instructions, see “Identifying a part by using the Virtual I/O Server.”

## Identifying a part by using the Virtual I/O Server

You can use Virtual I/O Server (VIOS) tools to physically locate a part.

To turn on the indicator light for identifying a part, follow these steps:

1. Log in as root user.
2. At the command line, type `diagmenu` and press Enter.
3. From the **Function Selection** menu, select **Task Selection** and press Enter.
4. From the **Task Selection** menu, select **Identify and Attention Indicators** and press Enter.
5. From the list of lights, select the location code for the failing part and press Enter.
6. Select **Commit**. This turns on the system attention and indicator light for the failing part.
7. Exit to the command line.

---

## Starting the system or logical partition

Learn how to start a system or logical partition after performing a service action or system upgrade.

---

### Starting a system that is not managed by an HMC or an SDMC

You can use the power button or the Advanced System Management Interface (ASMI) to start a system that is not managed by a Hardware Management Console (HMC) or an IBM Systems Director Management Console (SDMC).

To start a system that is not managed by a HMC or SDMC, follow these steps:

1. Open the front rack door, if necessary.
2. Before you press the power button on the control panel, ensure that power is connected to the system unit as follows:
  - All system power cables are connected to a power source.
  - The power LED, as shown in the following figure, is slowly flashing.
  - The top of the display, as shown in the following figure, shows 01 V=F.
3. Press the power button (**A**), as shown in the following figure, on the control panel.

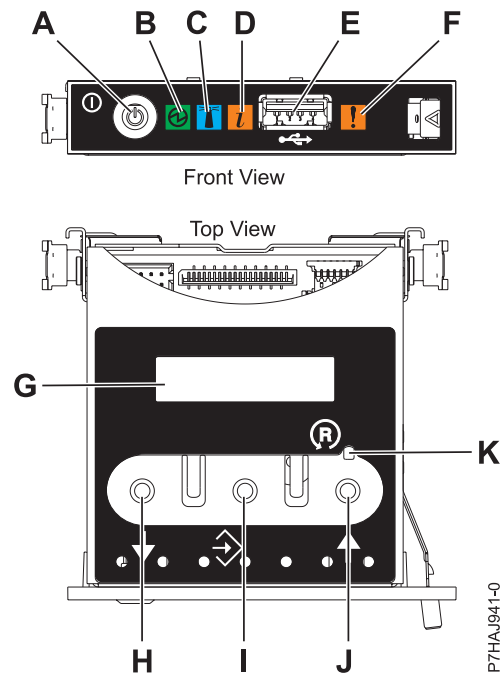

Figure 12. Control panel

- **A:** Power-on button
- **B:** Power LED
  - A constant light indicates full system power to the unit.
  - A flashing light indicates standby power to the unit.

**Note:** There is approximately a 30-second transition period from the time the power-on button is pressed to when the power LED goes from flashing to solid. During the transition period, the LED might flash faster.

- **C:** Enclosure identify light
    - A constant light indicates the identify state for the enclosure or for a resource within the enclosure.
    - No light indicates that no resources in the enclosure are being identified.
  - **D:** Attention light
    - No light indicates that the system is operating normally.
    - A solid light indicates that the system requires attention.
  - **E:** USB port
  - **F:** Enclosure fault roll-up light
    - A constant light indicates a fault indicator active in the system.
    - No light indicates that the system is operating normally.
  - **G:** Function/Data display
  - **H:** Decrement button
  - **I:** Enter button
  - **J:** Increment button
  - **K:** Pinhole reset button
4. Observe the following aspects after pressing the power button:
- The power-on light begins to flash faster.
  - The system cooling fans are activated after approximately 30 seconds and begin to accelerate to operating speed.
  - Progress indicators, also referred to as checkpoints, appear on the control panel display while the system is being started. The power-on light on the control panel stops flashing and remains on, indicating that the system power is on.

**Tip:** If pressing the power button does not start the system, do the following steps to start the system by using the Advanced System Management Interface (ASMI):

1. Access the ASMI. For instructions, see *Accessing the ASMI without an HMC*.
2. Start the system by using the ASMI. For instructions, see *Powering the system on and off*.

---

## Starting a system or logical partition by using the HMC

You can use the Hardware Management Console (HMC) to start the system or logical partition after the required cables are installed and the power cables are connected to a power source.

For instructions on working with the HMC, see *Managing the Hardware Management Console*. For instructions on starting a logical partition, see *Logical partitioning*. For instructions on starting the system, see *Powering on the managed system*.

Progress indicators, also referred to as checkpoints, appear on the control panel display while the system is being started. When the power-on light on the control panel stops blinking and remains on, the system power is on.

---

## Starting a system or virtual server by using the SDMC

You can use the IBM Systems Director Management Console (SDMC) to start the system or virtual server after the required cables are installed and the power cables are connected to a power source.

For instructions on working with the SDMC, see *Managing and configuring the SDMC*. For instructions on starting a virtual server, see *Managing virtual servers*. For instructions on shutting down and restarting virtual servers, see *Shutting down and restarting virtual servers*.

Progress indicators, also known as checkpoints, display on the control panel while the system is being started. When the power-on light on the control panel stops flashing and remains on, the system power is on.





---

## Stopping a system or logical partition

Learn how to stop a system or logical partition as a part of a system upgrade or service action.

**Attention:** Using either the power-on button on the control panel or entering commands at the Hardware Management Console (HMC) to stop the system can cause unpredictable results in the data files. Also, the next time you start the system, it might take longer if all applications are not ended before stopping the system.

To stop the system or logical partition, select the appropriate procedure.

---

### Stopping a system that is not managed by an HMC or an SDMC

You might need to stop the system to perform another task. If your system is not managed by the Hardware Management Console (HMC) or the IBM Systems Director Management Console (SDMC), use these instructions to stop the system by using the power button or the Advanced System Management Interface (ASMI).

Before you stop the system, follow these steps:

1. If an Integrated xSeries Adapter (IXA) is present on the system, shut it down using IBM i options.
2. Ensure that all jobs are completed and end all applications.
3. Ensure that the operating system is stopped.

**Attention:** Failure to do so can result in the loss of data.

4. If a Virtual I/O Server (VIOS) logical partition is running, ensure that all clients are shut down or that the clients have access to their devices by using an alternate method.

The following procedure describes how to stop a system that is not managed by the HMC or the SDMC.

1. Log in to the system as a user with the authority to run the **shutdown** or **pwrdownsys** (Power Down System) command.
2. At the command line, enter one of the following commands:
  - If your system is running the AIX operating system, type **shutdown**.
  - If your system is running the Linux operating system, type **shutdown -h now**.
  - If your system is running the IBM i operating system, type **PWRDWN SYS**. If your system is partitioned, use the **PWRDWN SYS** command to power down each of the secondary partitions. Then, use the **PWRDWN SYS** command to power down the primary partition.

The command stops the operating system. The system power turns off, the power-on light begins to slowly flash, and the system goes into a standby state.

3. At the Linux command line, type **shutdown -h now**.

The command stops the operating system. The system power turns off, the power-on light begins to slowly flash, and the system goes into a standby state.

4. Record the IPL type and the IPL mode from the control panel display to help you return the system to this state when the installation or replacement procedure is completed.
5. Set the power switches of any devices connected to the system to off.
6. Unplug any power cables that are attached to the peripheral devices, such as printers and expansion units.

**Important:** The system may be equipped with a second power supply. Before continuing with this procedure, ensure that all power sources to the system have been disconnected.

(L003)

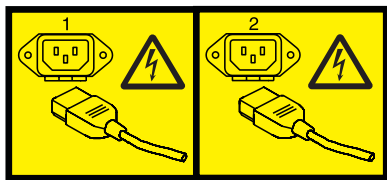

or



---

## Stopping a system by using the HMC

You can use the Hardware Management Console (HMC) to stop the system or a logical partition.

By default, the managed system is set to power off automatically when you shut down the last running logical partition on the managed system. If you set the managed system properties on the HMC so that the managed system does not power off automatically, you must use this procedure to power off your managed system.

**Attention:** If possible, shut down the running logical partitions on the managed system before powering off the managed system. Powering off the managed system without shutting down the logical partitions first causes the logical partitions to shut down abnormally and can cause data loss. If you use a Virtual I/O Server (VIOS) logical partition, ensure that all clients are shut down or that the clients have access to their devices using an alternate method.

To power off a managed system, you must be a member of one of the following roles:

- Super administrator
- Service representative
- Operator
- Product engineer

Use the following steps to stop the system by using the HMC:

1. In the navigation area, expand the **Systems Management** folder.
2. Click the **Servers** icon.
3. In the Contents area, select the managed system.

4. Select **Tasks > Operations > Power Off**.
5. Select the appropriate power-off mode and click **OK**.

**Related information:**

Shutting down and restarting logical partitions

---

## Stopping a system by using the SDMC

You can use the IBM Systems Director Management Console (SDMC) to stop the system or a virtual server.

By default, the managed system is set to power off automatically when you shut down the last running virtual server on the managed system. If you set the managed system properties on the SDMC so that the managed system does not power off automatically, you must use this procedure to power off your managed system.

**Attention:** If possible, shut down the running virtual servers on the managed system before powering off the managed system. Powering off the managed system without shutting down the virtual servers first causes the virtual servers to shut down abnormally and can cause data loss. If you use a Virtual I/O Server (VIOS) logical partition, ensure that all clients are shut down or that the clients have access to their devices with an alternate method.

To power off a managed system, you must be a member of one of the following roles:

- Super administrator
- Service representative
- Operator
- Product engineer

Use the following steps to stop the system by using the SDMC.

1. In the Power Systems Resource area, select the managed system you want to power off.
2. From the **Actions** menu, select **Operations > Power Off**.
3. Select the appropriate power-off mode and click **OK**.



---

## Removing and replacing covers for the 8233-E8B or 8236-E8C system

Use these instructions to remove, replace, or install covers so that you can access the hardware parts or perform service.

---

### Removing the front cover from an 8233-E8B or 8236-E8C system

Use this procedure to remove the cover to access components or perform service.

To remove the front cover, follow these steps:

1. Remove the two screws **(A)** that secure the system to the rack **(B)** as shown in the following figure.
2. Pull the cover away from the system. The cover has an indentation where you can hold onto it more easily.

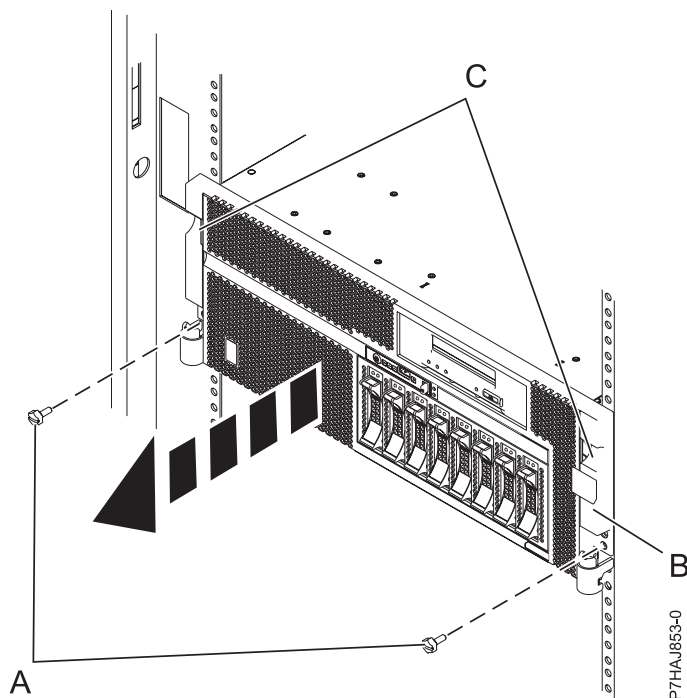

Figure 13. Removing the front cover

---

### Installing the front cover on an 8233-E8B or 8236-E8C system

Use this procedure to install the cover after accessing components or performing service.

To install the front cover, follow these steps:

1. Align the cover with the system.
2. Gently push the cover in until the four cover clips are seated in their respective mounting posts **(B)** on the system.
3. Replace the two screws **(C)** that secure the system to the rack **(A)**.

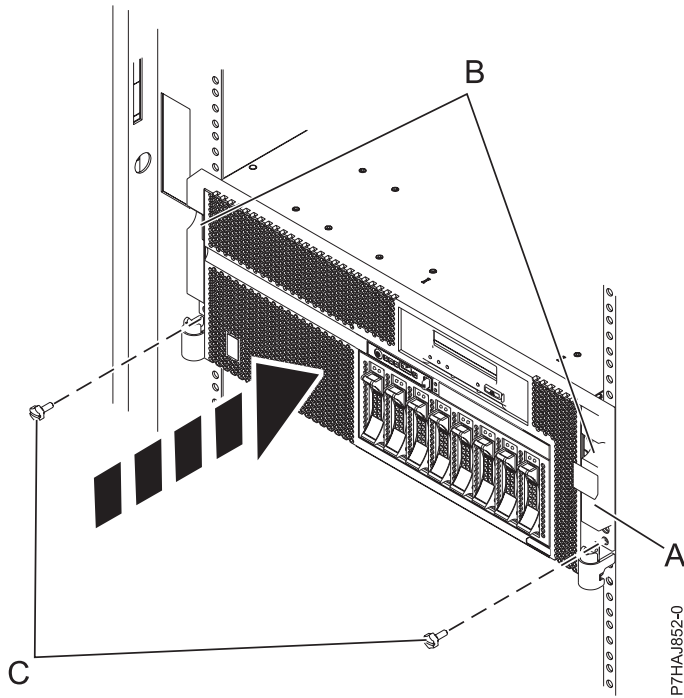

Figure 14. Installing the front cover

## Removing the service access cover from an 8233-E8B or 8236-E8C system

Use this procedure to remove the service access cover to perform service or to gain access to internal components.

To remove the service access cover, follow these steps:

1. Place the system into the service position. For instructions, see *Placing the 8233-E8B or 8236-E8C in the service position*.
2. Loosen the two thumbscrews (A) located at the rear of the cover.
3. Slide the cover (B) toward the rear of the system unit. When the front of the service access cover clears the upper frame ledge, lift the cover up and off the system unit.

**Attention:** For proper cooling and airflow, install the cover before starting the system. Operating the system without the cover for more than 30 minutes could damage the system components.

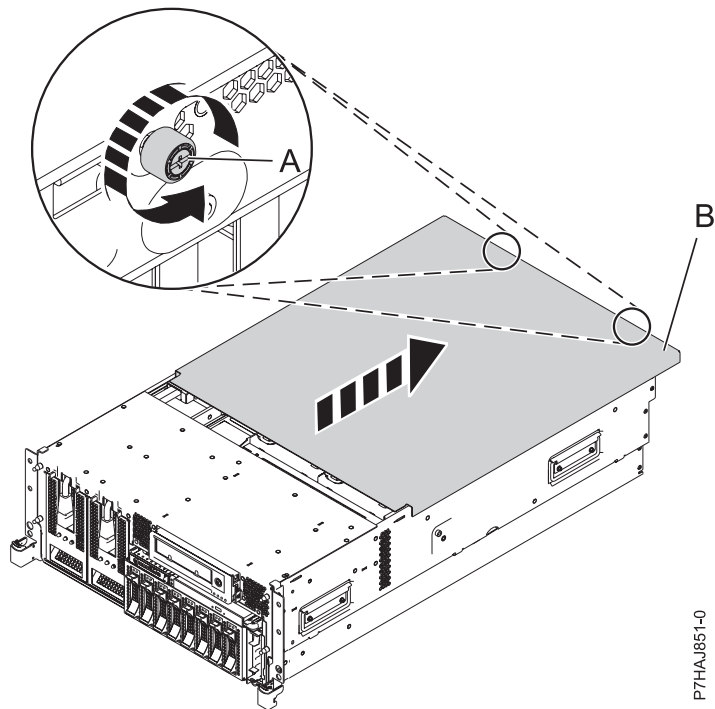

P7HAJ851-0

Figure 15. Removing the service access cover

**Related tasks:**

“Placing the 8233-E8B or 8236-E8C in the service position” on page 49

Use this procedure to perform service or gain access to internal components by placing the rack-mounted system or expansion unit in the service position.

---

## Installing the service access cover on an 8233-E8B or 8236-E8C system

Use this procedure to install the service access cover after performing service or accessing internal components.

To install the service access cover, follow these steps:

1. Place the service access cover (A) on the top of the system unit, approximately 25 mm (1 in.) from the front of the system unit.
2. Hold the service access cover against the system unit, and slide it toward the front of the system. The tabs on the service access cover slide beneath the upper chassis ledge, and the two screws align with the screw holes at the rear of the system unit.

**Important:** Ensure that the fan LED cables do not get caught on the front edge of the service access cover as you move it forward.

3. Tighten the screws (B) located at the rear of the cover.

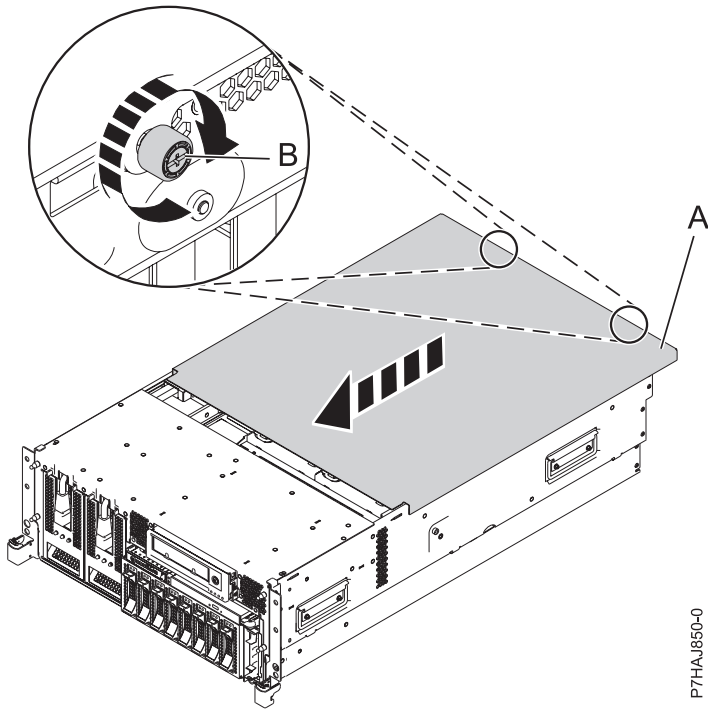

P7HAJ850-0

Figure 16. Installing the service access cover



---

## Placing the rack-mounted 8233-E8B or 8236-E8C system into the service position or operating position

Use these procedures to place a system into the service position or operating position to perform service or to gain access to internal components.

---

### Placing the 8233-E8B or 8236-E8C in the service position

Use this procedure to perform service or gain access to internal components by placing the rack-mounted system or expansion unit in the service position.

**Note:** Some of the figures in these procedures might not look exactly like the system or expansion unit that you have. However, the steps to perform the task are the same.

#### DANGER

When working on or around the system, observe the following precautions:

Electrical voltage and current from power, telephone, and communication cables are hazardous. To avoid a shock hazard:

- Connect power to this unit only with the IBM provided power cord. Do not use the IBM provided power cord for any other product.
- Do not open or service any power supply assembly.
- Do not connect or disconnect any cables or perform installation, maintenance, or reconfiguration of this product during an electrical storm.
- The product might be equipped with multiple power cords. To remove all hazardous voltages, disconnect all power cords.
- Connect all power cords to a properly wired and grounded electrical outlet. Ensure that the outlet supplies proper voltage and phase rotation according to the system rating plate.
- Connect any equipment that will be attached to this product to properly wired outlets.
- When possible, use one hand only to connect or disconnect signal cables.
- Never turn on any equipment when there is evidence of fire, water, or structural damage.
- Disconnect the attached power cords, telecommunications systems, networks, and modems before you open the device covers, unless instructed otherwise in the installation and configuration procedures.
- Connect and disconnect cables as described in the following procedures when installing, moving, or opening covers on this product or attached devices.

#### To Disconnect:

1. Turn off everything (unless instructed otherwise).
2. Remove the power cords from the outlets.
3. Remove the signal cables from the connectors.
4. Remove all cables from the devices.

#### To Connect:

1. Turn off everything (unless instructed otherwise).
2. Attach all cables to the devices.
3. Attach the signal cables to the connectors.
4. Attach the power cords to the outlets.
5. Turn on the devices.

(D005)

#### DANGER

Observe the following precautions when working on or around your IT rack system:

- Heavy equipment—personal injury or equipment damage might result if mishandled.
- Always lower the leveling pads on the rack cabinet.
- Always install stabilizer brackets on the rack cabinet.
- To avoid hazardous conditions due to uneven mechanical loading, always install the heaviest devices in the bottom of the rack cabinet. Always install servers and optional devices starting from the bottom of the rack cabinet.
- Rack-mounted devices are not to be used as shelves or work spaces. Do not place objects on top of rack-mounted devices.



- Each rack cabinet might have more than one power cord. Be sure to disconnect all power cords in the rack cabinet when directed to disconnect power during servicing.
- Connect all devices installed in a rack cabinet to power devices installed in the same rack cabinet. Do not plug a power cord from a device installed in one rack cabinet into a power device installed in a different rack cabinet.
- An electrical outlet that is not correctly wired could place hazardous voltage on the metal parts of the system or the devices that attach to the system. It is the responsibility of the customer to ensure that the outlet is correctly wired and grounded to prevent an electrical shock.

#### CAUTION

- Do not install a unit in a rack where the internal rack ambient temperatures will exceed the manufacturer's recommended ambient temperature for all your rack-mounted devices.
- Do not install a unit in a rack where the air flow is compromised. Ensure that air flow is not blocked or reduced on any side, front, or back of a unit used for air flow through the unit.
- Consideration should be given to the connection of the equipment to the supply circuit so that overloading of the circuits does not compromise the supply wiring or overcurrent protection. To provide the correct power connection to a rack, refer to the rating labels located on the equipment in the rack to determine the total power requirement of the supply circuit.
- *(For sliding drawers.)* Do not pull out or install any drawer or feature if the rack stabilizer brackets are not attached to the rack. Do not pull out more than one drawer at a time. The rack might become unstable if you pull out more than one drawer at a time.
- *(For fixed drawers.)* This drawer is a fixed drawer and must not be moved for servicing unless specified by the manufacturer. Attempting to move the drawer partially or completely out of the rack might cause the rack to become unstable or cause the drawer to fall out of the rack.

(R001)

To place the rack-mounted system or expansion unit into the service position, follow these steps:

1. If necessary, open the front rack door.
2. Remove the two screws **(A)** that secure the system unit to the rack as shown in the following figure.
3. Release the rack latches **(B)** on both the left and right sides as shown in the following figure.

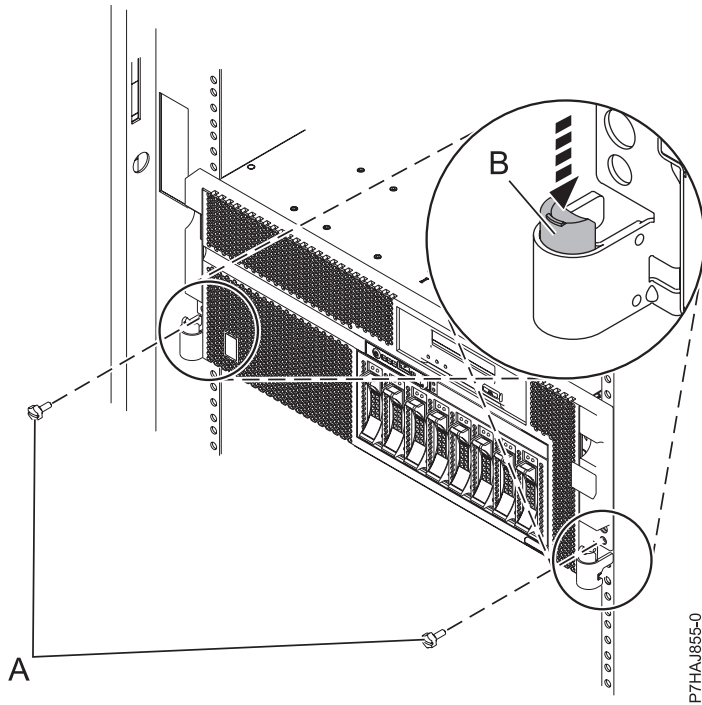

Figure 17. Releasing the rack latches

4. If required, unplug the cables from the rear of the system or expansion unit before you pull the unit out from the rack. Ensure that the cables at the rear of the system or expansion unit do not catch or bind as you pull the unit out from the rack.
5. Slowly pull the system or expansion unit out from the rack until the rails are fully extended and locked. Ensure that the rails are fully extended. When the rails are fully extended, the rail safety latches lock into place. This action prevents the system or expansion unit from being pulled out too far.

---

## Placing the 8233-E8B or 8236-E8C in the operating position

Use this procedure to place the system or expansion unit in the operating position to make the unit available for use.

To place the system into the operating position follow these steps:

**Tip:** Some of the figures in these procedures might not look exactly like the system or expansion unit that you have. However, the steps to perform the task are the same.

1. Simultaneously release the blue rail safety latches (**B**), located near the front of each rail, and push the system or expansion unit into the rack as shown in the following figure.

**Note:** Ensure that the cables at the rear of the system or expansion unit do not catch or bind as you push the unit back into the rack.

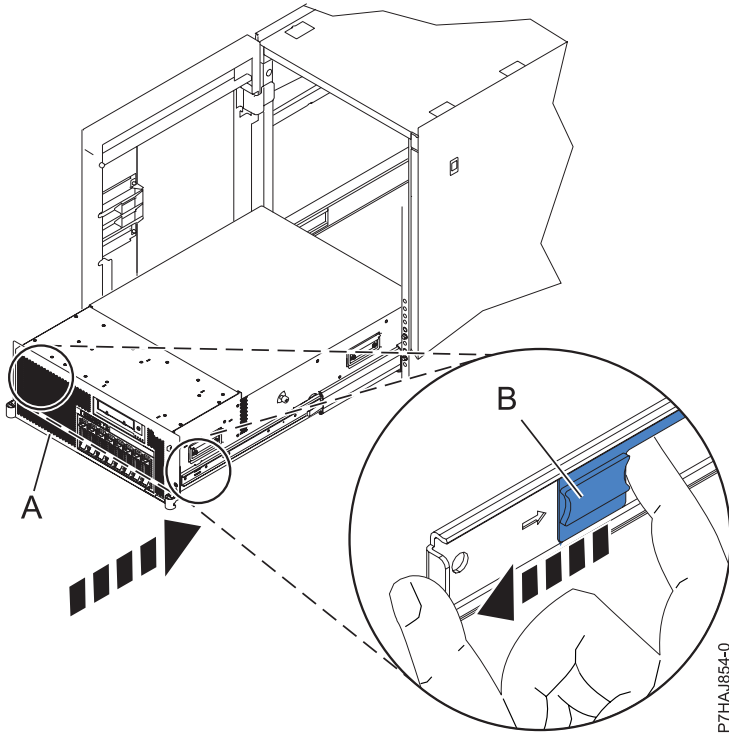

PTHAJ854-0

Figure 18. Releasing the rail safety latches

2. Replace and tighten the two thumbscrews (C) that secure the system or expansion unit (A) to the rack as shown in the following figure.

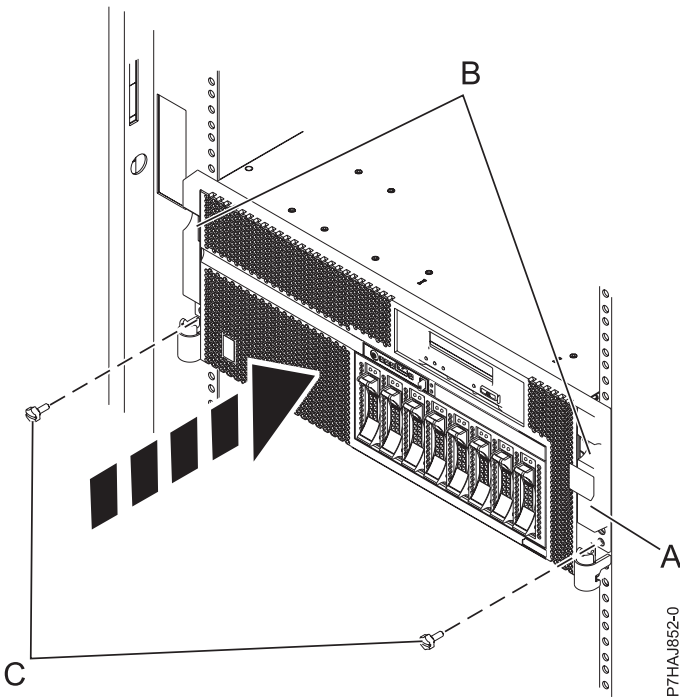

PTHAJ852-0

Figure 19. Replacing the thumbscrews

3. Close the front rack door.

---

## Verifying the installed part

You can verify a newly installed or replaced part on your system, logical partition, or expansion unit by using the operating system, stand-alone diagnostics, or the Hardware Management Console (HMC).

---

### Verifying an installed feature or replaced part in an AIX system or logical partition

If you installed feature or replaced a part, you might want to use the tools in the AIX operating system to verify that the feature or part is recognized by the system or logical partition.

To verify the operation of a newly installed feature or replacement part, select the appropriate procedure:

- Verify the installed feature using AIX
- Verifying the replaced part using AIX

Verify the installed feature by using the AIX operating system:

1. Log in as root user.
2. At the command line, type `diag` and press Enter.
3. Select **Advanced Diagnostics Routines** and press Enter.
4. From the **Diagnostic Mode Selection** menu, select **System Verification** and press Enter.
5. When the **Advanced Diagnostic Selection** menu appears, do one of the following:
  - To test a single resource, select the resource that you just installed from the list of resources and press Enter.
  - To test all the resources available to the operating system, select **All Resources** and press Enter.
6. Select **Commit**, and wait until the diagnostic programs run to completion, responding to any prompts that appear.
7. Did the diagnostics run to completion and display the message `No trouble was found`?
  - **No:** If a service request number (SRN) or other reference code is displayed, suspect a loose adapter or cable connection. Review the installation procedures to ensure that the new feature is installed correctly. If you cannot correct the problem, collect all SRNs or any other reference code information that you see. If the system is running in logical partitioning (LPAR) mode, note the logical partition in which you installed the feature. Contact your service provider for assistance.
  - **Yes:** The new device is installed correctly. Exit the diagnostic programs and return the system to normal operations.

Verify the replacement part by using the AIX operating system:

To verify the operation of a newly installed feature or replacement part, follow these steps:

1. Did you use either the AIX operating system or the online diagnostics service aid concurrent (hot-swap) service to replace the part?
  - No:** Go to step 2.
  - Yes:** Go to step 5 on page 54.
2. Is the system powered off?
  - No:** Go to step 4 on page 54.
  - Yes:** Continue with the next step.
3. Start the system and wait until the AIX operating system login prompt is displayed or until apparent system activity on the operator panel or display has stopped.

Did the AIX login prompt display?

- **No:** If a service request number (SRN) or other reference code is displayed, suspect a loose adapter or cable connection. Review the procedures for the part that you replaced to ensure that the new part is installed correctly. If you cannot correct the problem, collect all SRNs or any other reference code information that you see. If the system does not start or you have no login prompt, see: Problems with loading and starting the operating system.

If the system is partitioned, note the logical partition in which you replaced the part. Contact your service provider for assistance.

- **Yes:** Go to step 4.

4. At the command prompt, type `diag -a` and press Enter to check for missing resources. If you see a command prompt, go to step 5.

If the **Diagnostic selection** menu is shown with **M** appearing next to any resource, follow these steps:

- a. Select the resource and press Enter.
  - b. Select **Commit**.
  - c. Follow any instructions that are shown.
  - d. If the *Do you want to review the previously displayed error?* message is shown, select **Yes** and press Enter.
  - e. If an SRN is shown, suspect a loose card or connection. If no obvious problem is shown, record the SRN and contact your service provider for assistance.
  - f. If no SRN is shown, go to step 5.
5. Test the part by doing the following steps:
- a. At the command line, type `diag` and press Enter.
  - b. From the **Function Selection** menu, select **Advanced Diagnostics Routines** and press Enter.
  - c. From the **Diagnostic Mode Selection** menu, select **System Verification** and press Enter.
  - d. Select **All Resources**, or select the diagnostics for the individual part to test only the part you replaced and any devices that are attached to the part you replaced and press Enter.

Did the **Resource Repair Action** menu appear?

**No:** Go to step 6.

**Yes:** Go to step 7.

6. Did the *Testing Complete, No trouble was found* message appear?
  - **No:** There is still a problem. Contact your service provider. **This ends the procedure.**
  - **Yes:** Select **Log Repair Action**, if not previously logged, from the **Task Selection** menu to update the AIX error log. If the repair action was reseating a cable or adapter, select the resource associated with that repair action. If the resource associated with your action is not displayed on the resource list, select `sysplanar0` and press Enter.

**Tip:** This action changes the indicator light for the part from the fault state to the normal state.

Go to step 9 on page 55.

7. Select the resource for the replaced part from the **Resource Repair Action** menu. When a test is run on a resource in system verification mode, and that resource has an entry in the AIX error log, if the test on the resource was successful, the **Resource Repair Action** menu appears. Complete the following steps to update the AIX error log to indicate that a system-detectable part has been replaced.

**Note:** On systems with an indicator light for the failing part, this action changes the indicator light to the normal state.

- a. Select the resource that has been replaced from the **Resource Repair Action** menu. If the repair action was reseating a cable or adapter, select the resource associated with that repair action. If the resource associated with your action does not appear on the resource list, select **sysplanar0** and press Enter.
  - b. Select **Commit** after you make your selections. Did another **Resource Repair Action** display appear?
    - No:** If the **No Trouble Found** display appears, go to step 9
    - Yes:** Go to step 8.
8. Select the parent or child of the resource for the replaced part from the **Resource Repair Action** menu if necessary. When a test is run on a resource in system verification mode, and that resource has an entry in the AIX error log, if the test on the resource was successful, the **Resource Repair Action** menu appears. Complete the following steps to update the AIX error log to indicate that a system-detectable part has been replaced.
- Note:** This action changes the indicator light for the part from the fault state to the normal state.
- a. From the **Resource Repair Action** menu, select the parent or child of the resource that has been replaced. If the repair action was to reseat a cable or adapter, select the resource associated with that repair action. If the resource associated with your action does not appear on the resource list, select **sysplanar0** and press Enter.
  - b. Select **Commit** after you make your selections.
  - c. If the **No Trouble Found** display appears, go to step 9.
9. If you changed the service processor or network settings, as instructed in previous procedures, restore the settings to the values they had prior to servicing the system.
10. Did you do any hot-plug procedures before doing this procedure?
  - No:** Go to step 11.
  - Yes:** Go to step 12.
11. Start the operating system, with the system or logical partition in normal mode. Were you able to start the operating system?
  - No:** Contact your service provider. **This ends the procedure.**
  - Yes:** Go to step 12.
12. Are the indicator lights still on?
  - **No. This ends the procedure.**
  - **Yes.** Turn off the lights. See the following for instructions: Changing service indicators.

---

## Verifying the installed part in an IBM i system or logical partition

If you have installed a new feature or part, verify that the system recognizes the feature or part by using the IBM i system service tools.

To verify the installed part, follow these steps:

1. Deactivate the failing item indicator light. For instructions, see “Deactivating the failing-part indicator light” on page 34.
2. Sign on **with at least service level authority**.
3. On the command line of the IBM i session, type **strsst** and press Enter.

**Note:** If you cannot get to the System Service Tools display, use function 21 from the control panel. Alternatively, if the system is managed by Hardware Management Console (HMC), use the Service Focal Point Utilities to get to the Dedicated Service Tools (DST) display.

4. Type your service tools user ID and service tools password on the System Service Tools (SST) Sign On display and press Enter.



**Note:** The service tools password is case-sensitive.

5. Select **Start a service tool** from the System Service Tools (SST) display and press Enter.
6. Select **Hardware service manager** from the Start a Service Tool display and press Enter.
7. Select **Logical hardware resources (buses, IOPs, controllers)** from the Hardware Service Manager display and press Enter. This option allows you to display and work with logical resources. Logical hardware resources are the functional resources of the system used by the operating system.

With the Logical Hardware Resources display, you can show logical hardware resource status or information, and associated packaging hardware resources. Use the online Help information to better understand specific functions, fields, or symbols.

## Deactivating the failing-part indicator light

Use this procedure to turn off any indicator light that you turned on as a part of a service action.

To deactivate the indicator light, follow these steps:

1. Sign on to an IBM i session, **with at least service level authority**.
2. On the command line of the session, type `strsst` and press Enter.

**Note:** If you cannot get to the System Service Tools display, use function 21 from the control panel. Alternatively, if the system is managed by a Hardware Management Console (HMC), use the Service Focal Point utilities to get to the Dedicated Service Tools (DST) display.

3. Type your service tools user ID and service tools password on the System Service Tools (SST) Sign On display and press Enter.

**Remember:** The service tools password is case-sensitive.

4. Select **Start a service tool** from the System Service Tools (SST) display and press Enter.
5. Select **Hardware service manager** from the Start a Service Tool display and press Enter.
6. Select **Work with service action log** from the Hardware Service Manager display and press Enter.
7. On the Select Timeframe display, change the **From: Date and Time** field to a date and time prior to when the problem occurred.
8. Search for an entry that matches one or more conditions of the problem:
  - System reference code
  - Resource
  - Date and time
  - Failing item list
9. Select option 2 (Display failing item information) to display the service action log entry.
10. Select option 2 (Display details) to display location information for the failing part to be replaced. The information displayed in the date and time fields is the date and time for the first occurrence of the specific system reference code for the resource displayed during the time range selected.
11. Select option 7 (Indicator off) to turn off the indicator light.
12. Select the **Acknowledge all errors** function at the bottom of the Service Action Log display, if all problems have been resolved.
13. Close the log entry by selecting option 8 (Close new entry) on the Service Action Log Report display.

---

## Verifying the installed part in a Linux system or logical partition

If you have installed a new part, learn how to verify that the system recognizes the part.

To verify the newly installed or replaced part, continue with “Verifying an installed part by using stand-alone diagnostics” on page 57.



---

## Verifying an installed part by using stand-alone diagnostics

If you have installed or replaced a part, verify that the system recognizes the new part. You can use stand-alone diagnostics to verify an installed part in an AIX or Linux system, expansion unit, or logical partition.

- If this server is directly attached to another server or attached to a network, ensure communications with the other servers have stopped.
- The stand-alone diagnostics require use of all of the logical partition resources. No other activity can be running on the logical partition.
- The stand-alone diagnostics require access to the system console.

You access these diagnostics from a CD-ROM or from the Network Installation Management (NIM) server. This procedure describes how to use the diagnostics from a CD-ROM. For information on running diagnostics from the NIM server, see *Running stand-alone diagnostics from a Network Installation Management server*.

To use stand-alone diagnostics, follow these steps:

1. Stop all jobs and applications and then stop the operating system on the system or logical partition.
2. Remove all tapes, diskettes, and CD-ROM.
3. Turn off the system unit power. The next step boots the server or logical partition from the stand-alone diagnostics CD-ROM. If the optical drive is not available as a boot device on the server or logical partition on which you are working, follow these steps:
  - a. Access the ASMI. For information on using the ASMI, see *Accessing the ASMI*.
  - b. On the ASMI main menu, click **Power/Restart Control**.
  - c. Click **Power On/Off System**.
  - d. Select the **Service mode boot from default boot list** option in the AIX or Linux logical partition mode boot drop-down menu.
  - e. Click **Save settings and power on**. When the optical drive is powered on, insert the stand-alone diagnostic CD-ROM.
  - f. Go to step 5.
4. Turn on the system unit power and immediately insert the diagnostics CD-ROM into the optical drive.
5. After the **keyboard** POST indicator displays on the system console and before the last POST indicator (**speaker**) displays, press the numeric 5 key on the system console to indicate that a service mode boot must be initiated by using the default-service mode boot list.
6. Enter any requested password.
7. At the **Diagnostic Operating Instructions** display, press Enter.

**Tip:** If a service request number (SRN) or other reference code is displayed, suspect a loose adapter or cable connection.

**Note:** If you received an SRN or any other reference code when you attempted to start the system, contact your service provider for assistance.

8. If the terminal type is requested, select the **Initialize Terminal** option on the Function Selection menu to initialize the operating system.
9. From the Function Selection menu, select **Advanced Diagnostics Routines** and press Enter.
10. From the Diagnostic Mode Selection menu, select **System Verification** and press Enter.
11. When the Advanced Diagnostic Selection menu appears, select **All Resources**, or test only the part you replaced, and any devices that are attached to the part you replaced, by selecting the diagnostics for the individual part and press Enter.
12. Did the Testing Complete, No trouble was found message appear?

- **No:** There is still a problem. Contact your service provider.
  - **Yes:** Go to step 13.
13. If you changed the service processor or network settings, as instructed in previous procedures, restore the settings to the value they had prior to servicing the system.
  14. If the indicator lights are still on, follow these steps:
    - a. Select **Identify and Attention Indicators** from the Task Selection menu to turn off the system attention and indicator lights and press Enter.
    - b. Select **Set System Attention Indicator to NORMAL** and press Enter.
    - c. Select **Set All Identify Indicators to NORMAL** and press Enter.
    - d. Choose **Commit**.

**Note:** This changes the system attention and identify indicators from the *Fault* state to the *Normal* state.

- e. Exit to the command line.

---

## Verifying the installed part by using the HMC

If you have installed or replaced a part, use the Hardware Management Console (HMC) to update your HMC records after you have completed a service action on your server. If you have reference codes, symptoms, or location codes that you used during the service action, locate the records for use during this procedure.

To verify the installed part, complete these steps:

1. At the HMC, examine the service action event log for any open service action events. See “Viewing serviceable events by using the HMC” on page 59 for details.
2. Are there any service action events that are open?
  - No:** If the system attention LED is still on, use the HMC to turn off the LED. See “Activating and deactivating LEDs by using the HMC” on page 59. **This ends the procedure.**
  - Yes:** Continue with the next step.
3. Record the list of open service action events.
4. Examine the details of the open service action event. Is the error code associated with this service action event the same as you gathered earlier.
  - **No:** Select one of the following options:
    - Review the other serviceable events, find one that does match, and continue with the next step.
    - If the log does not match what you had gathered earlier, contact your service provider.
  - **Yes:** Continue with the next step.
5. Select and highlight the service action event from the Error Associated With This Serviceable Event window.
6. Click **Close Event**.
7. Add comments for the serviceable event. Include any unique additional information. Click **OK**.
8. Did you replace, add, or modify a field replaceable unit (FRU) of the open service action event?
  - **No:** Select the **No FRU Replaced for this Serviceable Event** option, and click **OK** to close the service action event.
  - **Yes:** Perform the following steps:
    - a. From the FRU list, select a FRU that you need to update.
    - b. Double-click the FRU and update the FRU information.
    - c. Click **OK** to close the service action event.
9. If you continue to have problems, contact your service provider.

## Activating and deactivating LEDs by using the HMC

Use this procedure to activate or deactivate LEDs by using Service Focal Point from the Hardware Management Console (HMC).

### Deactivating a system attention LED or partition LED by using the HMC

You can deactivate the attention LED for a system or logical partition if you decide that a problem is not a high priority and you decide to repair the problem at a later time. The deactivation also allows the LED to be activated again when another problem occurs.

To deactivate a system attention LED by using HMC, complete the following steps:

1. In the navigation area, open **Systems Management**.
2. Open **Servers** and select the required system.
3. In the content area, select the required partition.
4. Select **Tasks > Operations > Deactivate Attention LED**. A confirmation window is displayed with an indication that there still might be open problems with the system.
5. Click **OK** to continue with the deactivation. A window is displayed that provides the details of the system or partition, and a confirmation that the system or logical partition attention LED was deactivated.

### Activating or deactivating an identify LED by using the HMC

The system provides several LEDs that help identify various components, such as enclosures or field replaceable units (FRUs), in the system. For this reason, they are called *identify LEDs*.

You can activate or deactivate the following types of identify LEDs:

- **Identify LED for an enclosure** If you want to add an adapter to a specific drawer (enclosure), you need to know the machine type, model, and serial number (MTMS) of the drawer. To determine whether you have the correct MTMS for the drawer that needs the new adapter, you can activate the LED for a drawer and verify that the MTMS corresponds to the drawer that requires the new adapter.
- **Identify LED for a FRU associated with a specified enclosure** If you want to hook up a cable to a specific I/O adapter, you can activate the LED for the adapter which is a field replaceable unit (FRU), and then physically check to see where you should hook up the cable. This is especially useful when you have several adapters with open ports.

To activate or deactivate an identify LED for an enclosure or FRU, follow these steps:

1. In the navigation area, open **Systems Management**.
2. Select **Servers**.
3. In the content area, check the box for the appropriate System.
4. Select **Tasks > Operations > LED Status > Identify LED**.
5. To activate or deactivate an identify LED for an enclosure, select an enclosure from the table, and click either **Activate LED** or **Deactivate LED**. The associated LED is either turned on or off.
6. To activate or deactivate an identify LED for a FRU, select an enclosure from the table and click **List FRUs**.
7. Select one or more FRUs from the table, and click either **Activate LED** or **Deactivate LED**. The associated LED is either turned on or off.

## Viewing serviceable events by using the HMC

Use this procedure to view a serviceable event, including details, comments, and service history.

To view serviceable events and other information about the events, you must be a member of one of the following roles:

- Super administrator

- Service representative
- Operator
- Product engineer
- Viewer

To view serviceable events, follow these steps:

1. In the navigation area, select **Service Management**.
2. Select **Manage Serviceable Events**.
3. Select the criteria for the serviceable events that you want to view, and click **OK**. The Serviceable Event Overview window opens. The list shows all serviceable events that match your selection criteria. You can use the menu options to perform actions on the serviceable events.
4. Select a line in the Serviceable Event Overview window, and select **Selected > View Details**. The Serviceable Event Details window opens, showing detailed information about the serviceable event. The upper table shows information, such as problem number and reference code. The lower table shows the field replaceable units (FRUs) associated with this event.
5. Select the error for which you want to view comments and history, and follow these steps:
  - a. Select **Actions > View Comments**.
  - b. When you are finished viewing the comments, click **Close**.
  - c. Select **Actions > View Service History**. The Service History window opens, showing service history associated with the selected error.
  - d. When you are finished viewing the service history, click **Close**.
6. When you are finished, click **Cancel** twice to close the Serviceable Event Details window and the Serviceable Event Overview window.

---

## Verifying the installed part by using the SDMC

If you installed or replaced a part, use the IBM Systems Director Management Console (SDMC) to update your SDMC records after you have completed a service action on your server. If you have reference codes, symptoms, or location codes that you used during the service action, locate the records for use during this procedure.

To verify the installed part, complete these steps:

1. From the SDMC, examine the service action event log for any open service action events. See “Viewing serviceable events by using the SDMC” on page 62 for details.
2. Are there any service action events that are open?
  - No:** If the system attention LED is still on, use the SDMC to turn off the LED. See “Activating and deactivating LEDs by using the SDMC” on page 61. **This ends the procedure.**
  - Yes:** Continue with the next step.
3. Record the list of open service action events.
4. Examine the details of the open service action event. Is the error code associated with this service action event the same as you gathered earlier.
  - **No:** Select one of the following options:
    - Review the other serviceable events, find one that does match, and continue with the next step.
    - If the log does not match what you had gathered earlier, contact your service provider.
  - **Yes:** Continue with the next step.
5. Select and highlight the service action event from the Error Associated With This Serviceable Event window.
6. Click **Delete** or **Ignore**.

**Note:** These options are only available from the problem event log.

## Activating and deactivating LEDs by using the SDMC

Use this procedure to activate or deactivate LEDs by using the IBM Systems Director Management Console (SDMC).

### Deactivating a system attention LED or partition LED by using the SDMC

You can deactivate a system attention LED or a logical partition LED. For example, you might determine that a problem is not a high priority and decide to repair the problem at a later time. However, you want to be alerted if another problem occurs, so you must deactivate the system attention LED so that it can be activated again if another problem occurs.

To deactivate the system attention LED, complete the following steps:

1. On the Resources tab, select the appropriate host or virtual server.
2. Select **Actions > Service and Support > Hardware > System Attention LED**.
3. Select **Deactivate System Attention LED**. A confirmation window is displayed that provides the following information:
  - A verification that the system attention LED was deactivated.
  - An indication that there still might be open problems within the system.
  - An indication that you cannot activate the system attention LED.
4. Select one of the virtual servers, and select **Deactivate System Attention LED**. A confirmation window is displayed that provides the following information:
  - A verification that the system attention LED was deactivated.
  - An indication that there still might be open problems within the logical partition.
  - An indication that you cannot activate the virtual server LED.

### Activating or deactivating an identify LED by using the SDMC

The system provides several LEDs that help identify various components, such as enclosures or field replaceable units (FRUs). For this reason, they are called *identify LEDs*.

You can activate or deactivate the following types of identify LEDs:

- **Identify LED for an enclosure** If you want to add an adapter to a specific drawer (enclosure), you need to know the machine type, model, and serial number (MTMS) of the drawer. To determine whether you have the correct MTMS for the drawer that needs the new adapter, you can activate the LED for a drawer and verify that the MTMS corresponds to the drawer that requires the new adapter.
- **Identify LED for a FRU associated with a specified enclosure** If you want to hook up a cable to a specific I/O adapter, you can activate the LED for the adapter which is a field replaceable unit (FRU), and then physically check to see where you should hook up the cable. This is especially useful when you have several adapters with open ports.

To activate or deactivate an identify LED for an enclosure or FRU, follow these steps:

1. On the Resources tab, select the appropriate host or virtual server.
2. Select **Actions > Service and Support > Hardware > Identify LED**.
3. In the Identify LED, Select Enclosure window, select the system unit or enclosure.
4. To activate or deactivate an identify LED, click either **Activate LED** or **Deactivate LED**. The associated LED is either turned on or off.
5. To activate or deactivate an identify LED for a FRU, select a system or enclosure from the table, and then click **List FRUs**.
6. Select one or more FRUs from the table, and click either **Activate LED** or **Deactivate LED**. The associated LED is either turned on or off.

## Viewing serviceable events by using the SDMC

Use this procedure to view a serviceable event, including details, comments, and service history.

To view serviceable events, follow these steps:

1. On the Resources tab, select the appropriate host or virtual server.
2. Select **Actions > System Status and Health > Event Log**.
3. Optional: You can narrow the event criteria by using the Event filter menu.
4. Select a line in the Events window, and select **Actions > Properties**. The Properties window opens, showing detailed information about the serviceable event. The table shows information, such as problem number, reference code, and the field replaceable units (FRUs) associated with this event.

---

## Verifying an installed part or replaced part on a system or logical partition by using Virtual I/O Server tools

If you installed or replaced a part, you might want to use the tools in Virtual I/O Server (VIOS) to verify that the part is recognized by the system or logical partition.

### Verifying the installed part by using VIOS

You can verify the operation of a newly installed part or a replacement part.

Perform the following steps to verify an installed or replaced part:

1. Log in as root user.
2. At the command line, type `diagmenu` and press Enter.
3. Select **Advanced Diagnostics Routines** and press Enter.
4. From the **Diagnostic Mode Selection** menu, select **System Verification** and press Enter.
5. When the **Advanced Diagnostic Selection** menu appears, do one of the following steps:
  - To test a single resource, select the resource that you just installed from the list of resources and press Enter.
  - To test all the resources available to the operating system, select **All Resources** and press Enter.
6. Select **Commit**, and wait until the diagnostic programs run to completion, responding to any prompts that appear.
7. Did the diagnostics run to completion and display the message No trouble was found?
  - **No:** If a service request number (SRN) or other reference code is displayed, suspect a loose adapter or cable connection. Review the installation procedures to ensure that the new part is installed correctly. If you cannot correct the problem, collect all SRNs or any other reference code information that you see. If the system is running in LPAR mode, note the logical partition in which you installed the part. Contact your service provider for assistance.
  - **Yes:** The new device is installed correctly. Exit the diagnostic programs and return the system to normal operations.

### Verify the replacement part by using VIOS

To verify the operation of a newly installed part or replacement part, complete the following steps:

1. Did you replace the part by using either VIOS or the online diagnostics service aid's concurrent (hot-swap) service operation?
  - **No:** Go to step 2.
  - **Yes:** Go to step 5 on page 63.
2. Is the system powered off?
  - **No:** Go to step 4 on page 63.



- **Yes:** If the system supports slow boot, set the system to perform a slow boot. For information, see Performing a slow boot.
3. Start the system and wait until the VIOS operating system login prompt displays or until apparent system activity on the operator panel or display has stopped. Did the VIOS login prompt display?
    - **No:** If an SRN or other reference code is displayed, suspect a loose adapter or cable connection. Review the procedures for the part that you replaced to ensure that the new part is installed correctly. If you cannot correct the problem, collect all SRNs or any other reference code information that you see. If the system does not start or you have no login prompt, see Problems with loading and starting the operating system.  
If the system is partitioned, note the logical partition in which you replaced the part. Contact your service provider for assistance.
    - **Yes:** Go to step 4.
  4. At the command prompt, type `diag -a` and press Enter to check for missing resources. If you see a command prompt, go to step 5.  
If the **Diagnostic selection** menu is shown with **M** appearing next to any resource, follow these steps:
    - a. Select the resource and press Enter.
    - b. Select **Commit**.
    - c. Follow any instructions that are shown.
    - d. If a *Do you want to review the previously displayed error?* message is shown, select **Yes** and press Enter.
    - e. If an SRN is shown, suspect a loose card or connection. If no obvious problem is shown, record the SRN and contact your service provider for assistance.
    - f. If no SRN is shown, go to 5.
  5. Test the part by doing the following:
    - a. At the command line, type `diagmenu` and press Enter.
    - b. From the **Function Selection** menu, select **Advanced Diagnostics Routines** and press Enter.
    - c. From the **Diagnostic Mode Selection** menu, select **System Verification** and press Enter.
    - d. Select **All Resources**, or select the diagnostics for the individual part to test only the part you replaced, and any devices that are attached to the part you replaced and press Enter.  
Did the **Resource Repair Action** menu appear?
      - **No:** Go to step 6.
      - **Yes:** Go to step 7.
  6. Did the *Testing Complete, No trouble was found* message appear?
    - **No:** There is still a problem. Contact your service provider. **This ends the procedure.**
    - **Yes:** Select **Log Repair Action**, if not previously logged, from the **Task Selection** menu to update the error log. If the repair action was reseating a cable or adapter, select the resource associated with that repair action. If the resource associated with your action is not displayed on the Resource List, select `sysplanar0` and press Enter.  
  
**Tip:** This action changes the indicator light for the part from the fault state to the normal state. Go to step 9 on page 64.
  7. Select the resource for the replaced part from the **Resource Repair Action** menu. When a test is run on a resource in system verification mode, and that resource has an entry in the error log, if the test on the resource was successful, the **Resource Repair Action** menu appears. Complete the following steps to update the error log to indicate that a system-detectable part has been replaced. On systems with a indicator light for the failing part, this changes the indicator light to the normal state.

- a. Select the resource that has been replaced from the **Resource Repair Action** menu. If the repair action was reseating a cable or adapter, select the resource associated with that repair action. If the resource associated with your action does not appear on the Resource List, select **sysplanar0**. Press Enter.
- b. Select **Commit** after you make your selections. Did another **Resource Repair Action** display appear?
  - **No:** If the **No Trouble Found** display appears, go to step 9.
  - **Yes:** Go to step 8.
8. Select the parent or child of the resource for the replaced part from the **Resource Repair Action** menu if necessary. When a test is run on a resource in system verification mode, and that resource has an entry in the error log, if the test on the resource was successful, the **Resource Repair Action** menu appears. Complete the following steps to update the error log to indicate that a system-detectable part has been replaced. This changes the indicator light for the part from the fault state to the normal state.
  - a. From the **Resource Repair Action** menu, select the parent or child of the resource that has been replaced. If the repair action was to reseat a cable or adapter, select the resource associated with that repair action. If the resource associated with your action does not appear on the Resource List, select **sysplanar0**. Press Enter.
  - b. Select **Commit** after you make your selections.
    - a. If the **No Trouble Found** display appears, go to step 9.
9. If you changed the service processor or network settings, as instructed in previous procedures, restore the settings to the values they had prior to servicing the system.
10. Did you do any hot-plug procedures before doing this procedure?
  - **No:** Go to step 11.
  - **Yes:** Go to step 12.
11. Start the operating system, with the system or logical partition in normal mode. Were you able to start the operating system?
  - **No:** Contact your service provider. **This ends the procedure.**
  - **Yes:** Go to step 12.
12. Are the indicator lights still on?
  - **No:** This ends the procedure.
  - **Yes.** Turn off the lights. For instructions, see Changing service indicators.



---

## Notices

This information was developed for products and services offered in the U.S.A.

The manufacturer may not offer the products, services, or features discussed in this document in other countries. Consult the manufacturer's representative for information on the products and services currently available in your area. Any reference to the manufacturer's product, program, or service is not intended to state or imply that only that product, program, or service may be used. Any functionally equivalent product, program, or service that does not infringe any intellectual property right of the manufacturer may be used instead. However, it is the user's responsibility to evaluate and verify the operation of any product, program, or service.

The manufacturer may have patents or pending patent applications covering subject matter described in this document. The furnishing of this document does not grant you any license to these patents. You can send license inquiries, in writing, to the manufacturer.

**The following paragraph does not apply to the United Kingdom or any other country where such provisions are inconsistent with local law:** THIS PUBLICATION IS PROVIDED "AS IS" WITHOUT WARRANTY OF ANY KIND, EITHER EXPRESS OR IMPLIED, INCLUDING, BUT NOT LIMITED TO, THE IMPLIED WARRANTIES OF NON-INFRINGEMENT, MERCHANTABILITY OR FITNESS FOR A PARTICULAR PURPOSE. Some states do not allow disclaimer of express or implied warranties in certain transactions, therefore, this statement may not apply to you.

This information could include technical inaccuracies or typographical errors. Changes are periodically made to the information herein; these changes will be incorporated in new editions of the publication. The manufacturer may make improvements and/or changes in the product(s) and/or the program(s) described in this publication at any time without notice.

Any references in this information to websites not owned by the manufacturer are provided for convenience only and do not in any manner serve as an endorsement of those websites. The materials at those websites are not part of the materials for this product and use of those websites is at your own risk.

The manufacturer may use or distribute any of the information you supply in any way it believes appropriate without incurring any obligation to you.

Any performance data contained herein was determined in a controlled environment. Therefore, the results obtained in other operating environments may vary significantly. Some measurements may have been made on development-level systems and there is no guarantee that these measurements will be the same on generally available systems. Furthermore, some measurements may have been estimated through extrapolation. Actual results may vary. Users of this document should verify the applicable data for their specific environment.

Information concerning products not produced by this manufacturer was obtained from the suppliers of those products, their published announcements or other publicly available sources. This manufacturer has not tested those products and cannot confirm the accuracy of performance, compatibility or any other claims related to products not produced by this manufacturer. Questions on the capabilities of products not produced by this manufacturer should be addressed to the suppliers of those products.

All statements regarding the manufacturer's future direction or intent are subject to change or withdrawal without notice, and represent goals and objectives only.

The manufacturer's prices shown are the manufacturer's suggested retail prices, are current and are subject to change without notice. Dealer prices may vary.

This information is for planning purposes only. The information herein is subject to change before the products described become available.

This information contains examples of data and reports used in daily business operations. To illustrate them as completely as possible, the examples include the names of individuals, companies, brands, and products. All of these names are fictitious and any similarity to the names and addresses used by an actual business enterprise is entirely coincidental.

If you are viewing this information in softcopy, the photographs and color illustrations may not appear.

The drawings and specifications contained herein shall not be reproduced in whole or in part without the written permission of the manufacturer.

The manufacturer has prepared this information for use with the specific machines indicated. The manufacturer makes no representations that it is suitable for any other purpose.

The manufacturer's computer systems contain mechanisms designed to reduce the possibility of undetected data corruption or loss. This risk, however, cannot be eliminated. Users who experience unplanned outages, system failures, power fluctuations or outages, or component failures must verify the accuracy of operations performed and data saved or transmitted by the system at or near the time of the outage or failure. In addition, users must establish procedures to ensure that there is independent data verification before relying on such data in sensitive or critical operations. Users should periodically check the manufacturer's support websites for updated information and fixes applicable to the system and related software.

## Homologation statement

This product may not be certified in your country for connection by any means whatsoever to interfaces of public telecommunications networks. Further certification may be required by law prior to making any such connection. Contact an IBM representative or reseller for any questions.

---

## Trademarks

IBM, the IBM logo, and [ibm.com](http://ibm.com) are trademarks or registered trademarks of International Business Machines Corp., registered in many jurisdictions worldwide. Other product and service names might be trademarks of IBM or other companies. A current list of IBM trademarks is available on the web at Copyright and trademark information at [www.ibm.com/legal/copytrade.shtml](http://www.ibm.com/legal/copytrade.shtml).

Linux is a registered trademark of Linus Torvalds in the United States, other countries, or both.

---

## Electronic emission notices

When attaching a monitor to the equipment, you must use the designated monitor cable and any interference suppression devices supplied with the monitor.

## Class A Notices

The following Class A statements apply to the IBM servers that contain the POWER7 processor and its features unless designated as electromagnetic compatibility (EMC) Class B in the feature information.

## Federal Communications Commission (FCC) statement

**Note:** This equipment has been tested and found to comply with the limits for a Class A digital device, pursuant to Part 15 of the FCC Rules. These limits are designed to provide reasonable protection against harmful interference when the equipment is operated in a commercial environment. This equipment generates, uses, and can radiate radio frequency energy and, if not installed and used in accordance with

the instruction manual, may cause harmful interference to radio communications. Operation of this equipment in a residential area is likely to cause harmful interference, in which case the user will be required to correct the interference at his own expense.

Properly shielded and grounded cables and connectors must be used in order to meet FCC emission limits. IBM is not responsible for any radio or television interference caused by using other than recommended cables and connectors or by unauthorized changes or modifications to this equipment. Unauthorized changes or modifications could void the user's authority to operate the equipment.

This device complies with Part 15 of the FCC rules. Operation is subject to the following two conditions: (1) this device may not cause harmful interference, and (2) this device must accept any interference received, including interference that may cause undesired operation.

### **Industry Canada Compliance Statement**

This Class A digital apparatus complies with Canadian ICES-003.

### **Avis de conformité à la réglementation d'Industrie Canada**

Cet appareil numérique de la classe A est conforme à la norme NMB-003 du Canada.

### **European Community Compliance Statement**

This product is in conformity with the protection requirements of EU Council Directive 2004/108/EC on the approximation of the laws of the Member States relating to electromagnetic compatibility. IBM cannot accept responsibility for any failure to satisfy the protection requirements resulting from a non-recommended modification of the product, including the fitting of non-IBM option cards.

This product has been tested and found to comply with the limits for Class A Information Technology Equipment according to European Standard EN 55022. The limits for Class A equipment were derived for commercial and industrial environments to provide reasonable protection against interference with licensed communication equipment.

European Community contact:  
IBM Deutschland GmbH  
Technical Regulations, Department M372  
IBM-Allee 1, 71139 Ehningen, Germany  
Tele: +49 7032 15 2941  
email: lugi@de.ibm.com

**Warning:** This is a Class A product. In a domestic environment, this product may cause radio interference, in which case the user may be required to take adequate measures.

### **VCCI Statement - Japan**

この装置は、クラスA 情報技術装置です。この装置を家庭環境で使用すると電波妨害を引き起こすことがあります。この場合には使用者が適切な対策を講ずるよう要求されることがあります。

VCCI-A

The following is a summary of the VCCI Japanese statement in the box above:

This is a Class A product based on the standard of the VCCI Council. If this equipment is used in a domestic environment, radio interference may occur, in which case, the user may be required to take corrective actions.

### **Japanese Electronics and Information Technology Industries Association (JEITA) Confirmed Harmonics Guideline (products less than or equal to 20 A per phase)**

高調波ガイドライン適合品

### **Japanese Electronics and Information Technology Industries Association (JEITA) Confirmed Harmonics Guideline with Modifications (products greater than 20 A per phase)**

高調波ガイドライン準用品

### **Electromagnetic Interference (EMI) Statement - People's Republic of China**

#### **声 明**

此为 A 级产品,在生活环境中,  
该产品可能会造成无线电干扰。  
在这种情况下,可能需要用户对其  
干扰采取切实可行的措施。

Declaration: This is a Class A product. In a domestic environment this product may cause radio interference in which case the user may need to perform practical action.

### **Electromagnetic Interference (EMI) Statement - Taiwan**

#### **警告使用者：**

這是甲類的資訊產品，在  
居住的環境中使用時，可  
能會造成射頻干擾，在這  
種情況下，使用者會被要  
求採取某些適當的對策。

The following is a summary of the EMI Taiwan statement above.

Warning: This is a Class A product. In a domestic environment this product may cause radio interference in which case the user will be required to take adequate measures.

#### **IBM Taiwan Contact Information:**

台灣IBM 產品服務聯絡方式：  
台灣國際商業機器股份有限公司  
台北市松仁路7號3樓  
電話：0800-016-888

### **Electromagnetic Interference (EMI) Statement - Korea**

이 기기는 업무용(A급)으로 전자파적합기기로서 판매자 또는 사용자는 이 점을 주의하시기 바라며, 가정외의 지역에서 사용하는 것을 목적으로 합니다.

### **Germany Compliance Statement**

#### **Deutschsprachiger EU Hinweis: Hinweis für Geräte der Klasse A EU-Richtlinie zur Elektromagnetischen Verträglichkeit**

Dieses Produkt entspricht den Schutzanforderungen der EU-Richtlinie 2004/108/EG zur Angleichung der Rechtsvorschriften über die elektromagnetische Verträglichkeit in den EU-Mitgliedsstaaten und hält die Grenzwerte der EN 55022 Klasse A ein.

Um dieses sicherzustellen, sind die Geräte wie in den Handbüchern beschrieben zu installieren und zu betreiben. Des Weiteren dürfen auch nur von der IBM empfohlene Kabel angeschlossen werden. IBM übernimmt keine Verantwortung für die Einhaltung der Schutzanforderungen, wenn das Produkt ohne Zustimmung von IBM verändert bzw. wenn Erweiterungskomponenten von Fremdherstellern ohne Empfehlung von IBM gesteckt/eingebaut werden.

EN 55022 Klasse A Geräte müssen mit folgendem Warnhinweis versehen werden:

"Warnung: Dieses ist eine Einrichtung der Klasse A. Diese Einrichtung kann im Wohnbereich Funk-Störungen verursachen; in diesem Fall kann vom Betreiber verlangt werden, angemessene Maßnahmen zu ergreifen und dafür aufzukommen."

#### **Deutschland: Einhaltung des Gesetzes über die elektromagnetische Verträglichkeit von Geräten**

Dieses Produkt entspricht dem "Gesetz über die elektromagnetische Verträglichkeit von Geräten (EMVG)". Dies ist die Umsetzung der EU-Richtlinie 2004/108/EG in der Bundesrepublik Deutschland.

#### **Zulassungsbescheinigung laut dem Deutschen Gesetz über die elektromagnetische Verträglichkeit von Geräten (EMVG) (bzw. der EMC EG Richtlinie 2004/108/EG) für Geräte der Klasse A**

Dieses Gerät ist berechtigt, in Übereinstimmung mit dem Deutschen EMVG das EG-Konformitätszeichen - CE - zu führen.

Verantwortlich für die Einhaltung der EMV Vorschriften ist der Hersteller:  
International Business Machines Corp.  
New Orchard Road  
Armonk, New York 10504  
Tel: 914-499-1900

Der verantwortliche Ansprechpartner des Herstellers in der EU ist:  
IBM Deutschland GmbH  
Technical Regulations, Abteilung M372  
IBM-Allee 1, 71139 Ehningen, Germany  
Tel: +49 7032 15 2941  
email: lugi@de.ibm.com

Generelle Informationen:

Das Gerät erfüllt die Schutzanforderungen nach EN 55024 und EN 55022 Klasse A.

### **Electromagnetic Interference (EMI) Statement - Russia**

**ВНИМАНИЕ!** Настоящее изделие относится к классу А.  
В жилых помещениях оно может создавать  
радиопомехи, для снижения которых необходимы  
дополнительные меры

---

## **Terms and conditions**

Permissions for the use of these publications are granted subject to the following terms and conditions.

**Applicability:** These terms and conditions are in addition to any terms of use for the IBM website.

**Personal Use:** You may reproduce these publications for your personal, noncommercial use provided that all proprietary notices are preserved. You may not distribute, display or make derivative works of these publications, or any portion thereof, without the express consent of IBM.

**Commercial Use:** You may reproduce, distribute and display these publications solely within your enterprise provided that all proprietary notices are preserved. You may not make derivative works of these publications, or reproduce, distribute or display these publications or any portion thereof outside your enterprise, without the express consent of IBM.

**Rights:** Except as expressly granted in this permission, no other permissions, licenses or rights are granted, either express or implied, to the Publications or any information, data, software or other intellectual property contained therein.

IBM reserves the right to withdraw the permissions granted herein whenever, in its discretion, the use of the publications is detrimental to its interest or, as determined by IBM, the above instructions are not being properly followed.

You may not download, export or re-export this information except in full compliance with all applicable laws and regulations, including all United States export laws and regulations.

IBM MAKES NO GUARANTEE ABOUT THE CONTENT OF THESE PUBLICATIONS. THE PUBLICATIONS ARE PROVIDED "AS-IS" AND WITHOUT WARRANTY OF ANY KIND, EITHER

EXPRESSED OR IMPLIED, INCLUDING BUT NOT LIMITED TO IMPLIED WARRANTIES OF MERCHANTABILITY, NON-INFRINGEMENT, AND FITNESS FOR A PARTICULAR PURPOSE.









Printed in USA