

Power Systems

*5796 and 7314 model G30 removal  
and replacement procedures*

**IBM**



Power Systems

*5796 and 7314 model G30 removal  
and replacement procedures*

**IBM**

**Note**

Before using this information and the product it supports, read the information in “Notices” on page 23, “Safety notices” on page v, the *IBM Systems Safety Notices* manual, G229-9054, and the *IBM Environmental Notices and User Guide*, Z125-5823.

This edition applies to IBM Power Systems™ servers that contain the POWER7 processor and to all associated models.

© Copyright IBM Corporation 2008, 2010.

US Government Users Restricted Rights – Use, duplication or disclosure restricted by GSA ADP Schedule Contract with IBM Corp.

---

# Contents

<b>Safety notices</b> . . . . .	<b>v</b>
<b>Removal and replacement procedures</b> . . . . .	<b>1</b>
Removal and replacement procedures . . . . .	1
GX Dual-Port 12X Channel Attach adapter . . . . .	3
PCI adapter. . . . .	7
PCI shuttle assembly . . . . .	7
Power supply . . . . .	14
SPCN card . . . . .	18
<b>Notices</b> . . . . .	<b>23</b>
Trademarks . . . . .	24
Electronic emission notices . . . . .	24
Class A Notices . . . . .	24
Terms and conditions . . . . .	28



---

## Safety notices

Safety notices may be printed throughout this guide:

- **DANGER** notices call attention to a situation that is potentially lethal or extremely hazardous to people.
- **CAUTION** notices call attention to a situation that is potentially hazardous to people because of some existing condition.
- **Attention** notices call attention to the possibility of damage to a program, device, system, or data.

### World Trade safety information

Several countries require the safety information contained in product publications to be presented in their national languages. If this requirement applies to your country, safety information documentation is included in the publications package (such as in printed documentation, on DVD, or as part of the product) shipped with the product. The documentation contains the safety information in your national language with references to the U.S. English source. Before using a U.S. English publication to install, operate, or service this product, you must first become familiar with the related safety information documentation. You should also refer to the safety information documentation any time you do not clearly understand any safety information in the U.S. English publications.

Replacement or additional copies of safety information documentation can be obtained by calling the IBM Hotline at 1-800-300-8751.

### German safety information

Das Produkt ist nicht für den Einsatz an Bildschirmarbeitsplätzen im Sinne § 2 der Bildschirmarbeitsverordnung geeignet.

### Laser safety information

IBM® servers can use I/O cards or features that are fiber-optic based and that utilize lasers or LEDs.

### Laser compliance

IBM servers may be installed inside or outside of an IT equipment rack.

## DANGER

When working on or around the system, observe the following precautions:

Electrical voltage and current from power, telephone, and communication cables are hazardous. To avoid a shock hazard:

- Connect power to this unit only with the IBM provided power cord. Do not use the IBM provided power cord for any other product.
- Do not open or service any power supply assembly.
- Do not connect or disconnect any cables or perform installation, maintenance, or reconfiguration of this product during an electrical storm.
- The product might be equipped with multiple power cords. To remove all hazardous voltages, disconnect all power cords.
- Connect all power cords to a properly wired and grounded electrical outlet. Ensure that the outlet supplies proper voltage and phase rotation according to the system rating plate.
- Connect any equipment that will be attached to this product to properly wired outlets.
- When possible, use one hand only to connect or disconnect signal cables.
- Never turn on any equipment when there is evidence of fire, water, or structural damage.
- Disconnect the attached power cords, telecommunications systems, networks, and modems before you open the device covers, unless instructed otherwise in the installation and configuration procedures.
- Connect and disconnect cables as described in the following procedures when installing, moving, or opening covers on this product or attached devices.

To Disconnect:

1. Turn off everything (unless instructed otherwise).
2. Remove the power cords from the outlets.
3. Remove the signal cables from the connectors.
4. Remove all cables from the devices.

To Connect:

1. Turn off everything (unless instructed otherwise).
2. Attach all cables to the devices.
3. Attach the signal cables to the connectors.
4. Attach the power cords to the outlets.
5. Turn on the devices.

(D005)

## DANGER



Observe the following precautions when working on or around your IT rack system:

- Heavy equipment—personal injury or equipment damage might result if mishandled.
- Always lower the leveling pads on the rack cabinet.
- Always install stabilizer brackets on the rack cabinet.
- To avoid hazardous conditions due to uneven mechanical loading, always install the heaviest devices in the bottom of the rack cabinet. Always install servers and optional devices starting from the bottom of the rack cabinet.
- Rack-mounted devices are not to be used as shelves or work spaces. Do not place objects on top of rack-mounted devices.



- Each rack cabinet might have more than one power cord. Be sure to disconnect all power cords in the rack cabinet when directed to disconnect power during servicing.
- Connect all devices installed in a rack cabinet to power devices installed in the same rack cabinet. Do not plug a power cord from a device installed in one rack cabinet into a power device installed in a different rack cabinet.
- An electrical outlet that is not correctly wired could place hazardous voltage on the metal parts of the system or the devices that attach to the system. It is the responsibility of the customer to ensure that the outlet is correctly wired and grounded to prevent an electrical shock.

#### CAUTION

- Do not install a unit in a rack where the internal rack ambient temperatures will exceed the manufacturer's recommended ambient temperature for all your rack-mounted devices.
- Do not install a unit in a rack where the air flow is compromised. Ensure that air flow is not blocked or reduced on any side, front, or back of a unit used for air flow through the unit.
- Consideration should be given to the connection of the equipment to the supply circuit so that overloading of the circuits does not compromise the supply wiring or overcurrent protection. To provide the correct power connection to a rack, refer to the rating labels located on the equipment in the rack to determine the total power requirement of the supply circuit.
- *(For sliding drawers.)* Do not pull out or install any drawer or feature if the rack stabilizer brackets are not attached to the rack. Do not pull out more than one drawer at a time. The rack might become unstable if you pull out more than one drawer at a time.
- *(For fixed drawers.)* This drawer is a fixed drawer and must not be moved for servicing unless specified by the manufacturer. Attempting to move the drawer partially or completely out of the rack might cause the rack to become unstable or cause the drawer to fall out of the rack.

(R001)

**CAUTION:**

Removing components from the upper positions in the rack cabinet improves rack stability during relocation. Follow these general guidelines whenever you relocate a populated rack cabinet within a room or building:

- Reduce the weight of the rack cabinet by removing equipment starting at the top of the rack cabinet. When possible, restore the rack cabinet to the configuration of the rack cabinet as you received it. If this configuration is not known, you must observe the following precautions:
  - Remove all devices in the 32U position and above.
  - Ensure that the heaviest devices are installed in the bottom of the rack cabinet.
  - Ensure that there are no empty U-levels between devices installed in the rack cabinet below the 32U level.
- If the rack cabinet you are relocating is part of a suite of rack cabinets, detach the rack cabinet from the suite.
- Inspect the route that you plan to take to eliminate potential hazards.
- Verify that the route that you choose can support the weight of the loaded rack cabinet. Refer to the documentation that comes with your rack cabinet for the weight of a loaded rack cabinet.
- Verify that all door openings are at least 760 x 230 mm (30 x 80 in.).
- Ensure that all devices, shelves, drawers, doors, and cables are secure.
- Ensure that the four leveling pads are raised to their highest position.
- Ensure that there is no stabilizer bracket installed on the rack cabinet during movement.
- Do not use a ramp inclined at more than 10 degrees.
- When the rack cabinet is in the new location, complete the following steps:
  - Lower the four leveling pads.
  - Install stabilizer brackets on the rack cabinet.
  - If you removed any devices from the rack cabinet, repopulate the rack cabinet from the lowest position to the highest position.
- If a long-distance relocation is required, restore the rack cabinet to the configuration of the rack cabinet as you received it. Pack the rack cabinet in the original packaging material, or equivalent. Also lower the leveling pads to raise the casters off of the pallet and bolt the rack cabinet to the pallet.

(R002)

(L001)



(L002)



(L003)



or



All lasers are certified in the U.S. to conform to the requirements of DHHS 21 CFR Subchapter J for class 1 laser products. Outside the U.S., they are certified to be in compliance with IEC 60825 as a class 1 laser product. Consult the label on each part for laser certification numbers and approval information.

**CAUTION:**

This product might contain one or more of the following devices: CD-ROM drive, DVD-ROM drive, DVD-RAM drive, or laser module, which are Class 1 laser products. Note the following information:

- Do not remove the covers. Removing the covers of the laser product could result in exposure to hazardous laser radiation. There are no serviceable parts inside the device.
- Use of the controls or adjustments or performance of procedures other than those specified herein might result in hazardous radiation exposure.

(C026)

**CAUTION:**

Data processing environments can contain equipment transmitting on system links with laser modules that operate at greater than Class 1 power levels. For this reason, never look into the end of an optical fiber cable or open receptacle. (C027)

**CAUTION:**

This product contains a Class 1M laser. Do not view directly with optical instruments. (C028)

**CAUTION:**

Some laser products contain an embedded Class 3A or Class 3B laser diode. Note the following information: laser radiation when open. Do not stare into the beam, do not view directly with optical instruments, and avoid direct exposure to the beam. (C030)

**CAUTION:**

The battery contains lithium. To avoid possible explosion, do not burn or charge the battery.

*Do Not:*

- \_\_\_ Throw or immerse into water
- \_\_\_ Heat to more than 100°C (212°F)
- \_\_\_ Repair or disassemble

Exchange only with the IBM-approved part. Recycle or discard the battery as instructed by local regulations. In the United States, IBM has a process for the collection of this battery. For information, call 1-800-426-4333. Have the IBM part number for the battery unit available when you call. (C003)

## **Power and cabling information for NEBS (Network Equipment-Building System) GR-1089-CORE**

The following comments apply to the IBM servers that have been designated as conforming to NEBS (Network Equipment-Building System) GR-1089-CORE:

The equipment is suitable for installation in the following:

- Network telecommunications facilities
- Locations where the NEC (National Electrical Code) applies

The intrabuilding ports of this equipment are suitable for connection to intrabuilding or unexposed wiring or cabling only. The intrabuilding ports of this equipment *must not* be metallically connected to the interfaces that connect to the OSP (outside plant) or its wiring. These interfaces are designed for use as intrabuilding interfaces only (Type 2 or Type 4 ports as described in GR-1089-CORE) and require isolation from the exposed OSP cabling. The addition of primary protectors is not sufficient protection to connect these interfaces metallically to OSP wiring.

**Note:** All Ethernet cables must be shielded and grounded at both ends.

The ac-powered system does not require the use of an external surge protection device (SPD).

The dc-powered system employs an isolated DC return (DC-I) design. The DC battery return terminal *shall not* be connected to the chassis or frame ground.

---

## Removal and replacement procedures

Here you will find installation and maintenance information for the 5796 and 7314-G30 expansion units.

---

### Removal and replacement procedures

Use the removal and replacement procedures when you repair, maintain, or exchange your system parts.

Before you begin a replacement, perform these tasks:

1. If you are performing a replacement procedure that might put your data at risk, ensure, if possible, that you have a current backup of your system or logical partition (including operating systems, licensed programs, and data).
2. Review the installation or replacement procedure for the feature or part.
3. Note the significance of color on your system. Blue or Terra-cotta on a part of the hardware indicates a touch point where you can grip the hardware to remove it from or install it in the system, open or close a latch, and so on. **Terra-cotta** might also indicate that the part can be removed and replaced with the system or logical partition power on.
4. Ensure that you have access to a medium, flat-blade screwdriver.
5. If parts are incorrect, missing, or visibly damaged, contact your service provider or next level of support.

## DANGER

When working on or around the system, observe the following precautions:

Electrical voltage and current from power, telephone, and communication cables are hazardous. To avoid a shock hazard:

- Connect power to this unit only with the IBM provided power cord. Do not use the IBM provided power cord for any other product.
- Do not open or service any power supply assembly.
- Do not connect or disconnect any cables or perform installation, maintenance, or reconfiguration of this product during an electrical storm.
- The product might be equipped with multiple power cords. To remove all hazardous voltages, disconnect all power cords.
- Connect all power cords to a properly wired and grounded electrical outlet. Ensure that the outlet supplies proper voltage and phase rotation according to the system rating plate.
- Connect any equipment that will be attached to this product to properly wired outlets.
- When possible, use one hand only to connect or disconnect signal cables.
- Never turn on any equipment when there is evidence of fire, water, or structural damage.
- Disconnect the attached power cords, telecommunications systems, networks, and modems before you open the device covers, unless instructed otherwise in the installation and configuration procedures.
- Connect and disconnect cables as described in the following procedures when installing, moving, or opening covers on this product or attached devices.

To Disconnect:

1. Turn off everything (unless instructed otherwise).
2. Remove the power cords from the outlets.
3. Remove the signal cables from the connectors.
4. Remove all cables from the devices.

To Connect:

1. Turn off everything (unless instructed otherwise).
2. Attach all cables to the devices.
3. Attach the signal cables to the connectors.
4. Attach the power cords to the outlets.
5. Turn on the devices.

(D005)

### Attention:

Failure to follow the step-by-step sequence for FRU removal and/or installation may result in FRU or system damage.

Use the following precautions whenever you handle electronic components or cables.

- The electrostatic discharge (ESD) kit and the ESD wrist strap must be used when handling logic cards, SCMs, MCMs, electronic boards, and disk drives.
- Keep all electronic components in the shipping container or envelope until you are ready to install them.
- If you remove, then reinstall an electronic component, temporarily place the component on an ESD pad or blanket.

## GX Dual-Port 12X Channel Attach adapter

Use this procedure to service the GX Dual-Port 12X Channel Attach adapter.

This unit will be serviced nonconcurrently.

Power should be removed from the unit containing the FRU in the location field above. If this unit is powered on, power it off now. When the unit is completely powered off, disconnect the ac input source by removing the power cord from the unit. Do not apply power to the unit until directed to do so in this procedure.

You must also power down the server connected to the 7314-G30 or feature code 5796 if the server and system firmware combination is one of the following:

- 9406-MMA or 9117-MMA with system firmware level equal to or less than EM320\_040\_031 or EM310\_069\_048.
  - 8204-E8A with system firmware level equal to or less than EL320\_040\_031.
- 

### 1. Remove the cable-management bracket

1. Label, then disconnect the ac power cords from the back of the system.
2. Remove the cable-management bracket retaining screw (A).

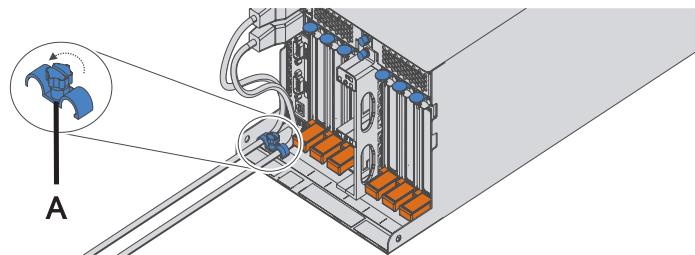

---

### 2. Remove the power supplies

1. Rotate the power supply handle (A) in the direction shown to unseat the power supply.
2. Pull the power supply straight out from the I/O subsystem.
3. Repeat these steps to remove the other power supply.
4. Turn the blue thumbscrews (B) in the direction shown to unlock the PCI shuttle assembly.

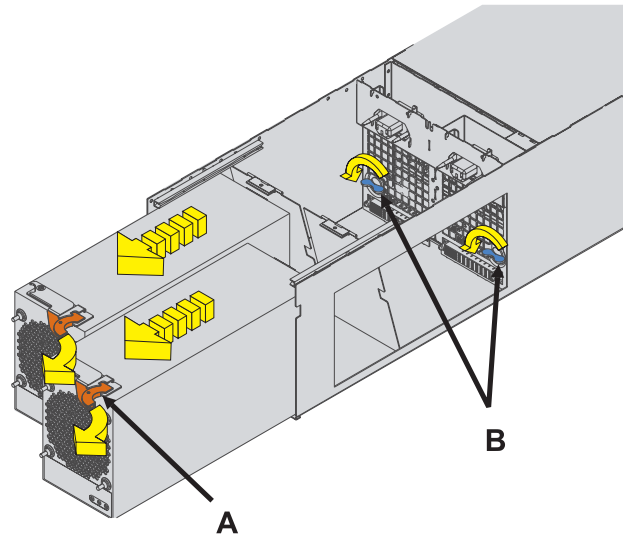

---

### 3. Remove the PCI shuttle assembly

Slide the PCI shuttle assembly from the I/O subsystem as shown in the diagram.

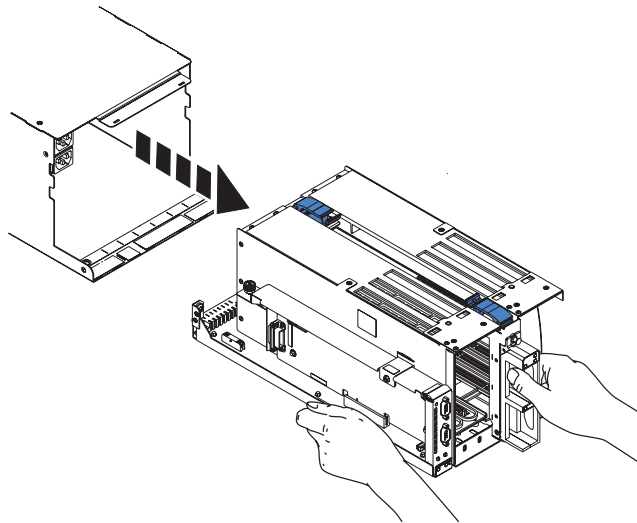

---

### 4. Remove the GX Card



1. Pull out the locking knob **(A)** and remove the front GX card cover.
2. Squeeze the release latches **(B)** to release them from the card and rotate in the direction shown.
3. Carefully pull the card out of the slot.

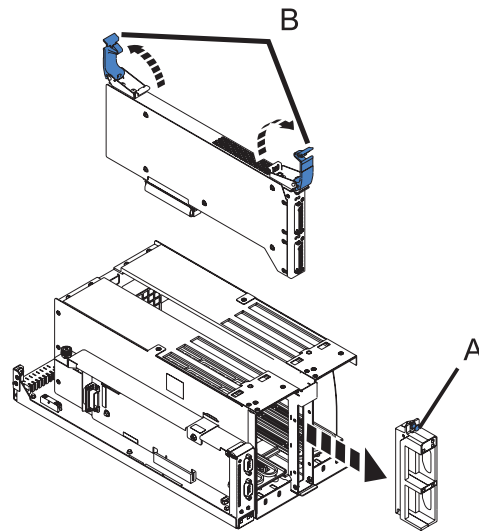

---

## 5. Install the GX Card

1. Carefully push the card into the slot.
2. Rotate the release latches **(A)** in the direction shown, then push them down to secure the card.
3. Install the front GX card cover and push in the locking knob **(B)**.

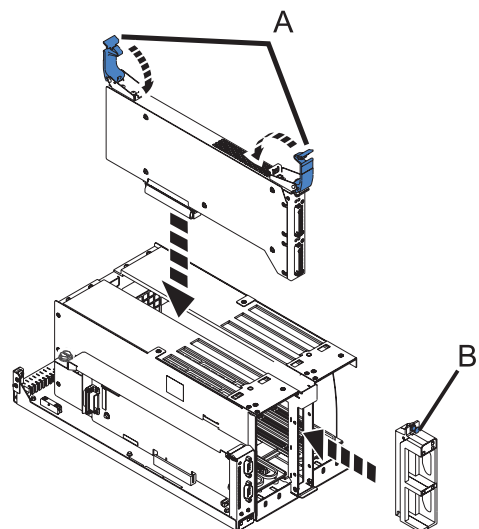

---

## 6. Install the PCI shuttle assembly

1. Slide the PCI shuttle assembly into the I/O subsystem as shown in the diagram.
2. Reconnect all PCI and SPCN cables previously removed from their adapters.
3. Connect the cable that was previously removed to the GX card.

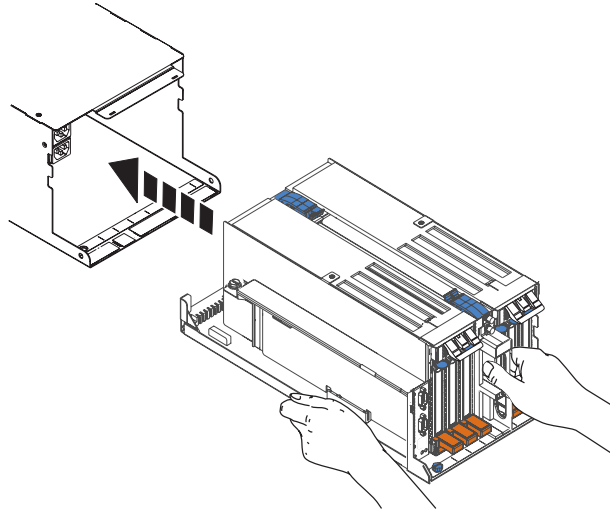

---

## 7. Install the power supplies

1. Turn the blue thumbscrews (A) in the direction shown to lock the PCI shuttle assembly.
2. Push the power supply straight into the I/O subsystem.
3. Rotate the power supply handle (B) in the direction shown to seat the power supply.
4. Repeat the steps to install the other power supply.

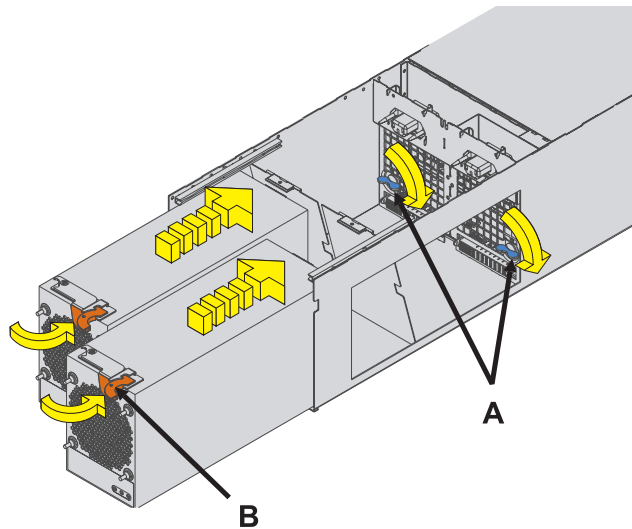

---

## 8. Install the cable-management bracket

1. From the back of the rack, install the cable-management bracket retaining screw (A).
2. Reconnect the ac power cords to the back of the system.

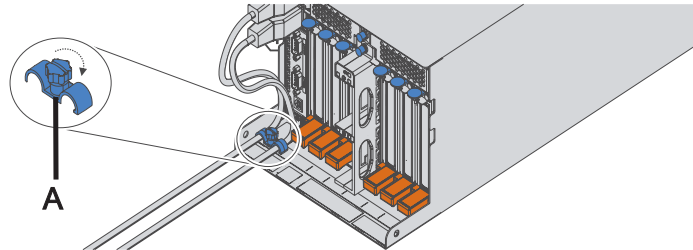

---

## 9. Verify the repair

Go to Verification Procedures.

---

## PCI adapter

Use this procedure to service a PCI adapter.

If your system is managed by the Hardware Management Console (HMC), use the HMC to complete the steps for removing and replacing a PCI adapter. For instructions, see *Removing a part by using the Hardware Management Console*.

The PCI adapter is serviced concurrently. Select the procedure below based on your operating system.

If you are doing a concurrent repair by using the AIX® operating system, go to *Removing and replacing a PCI adapter contained in a cassette in an AIX partition that is powered on*.

If you are doing a concurrent repair by using the IBM i operating system, go to *Removing and replacing a PCI adapter contained in a cassette in an IBM i partition that is powered on*.

If you are doing a concurrent repair by using the Linux operating system, go to *Removing and replacing a PCI adapter contained in a cassette in a Linux partition that is powered on*.

---

## PCI shuttle assembly

Use this procedure to service the PCI shuttle assembly.

- 1.

This unit will be serviced nonconcurrently.

Before you replace this field-replaceable unit (FRU), record Vital Product Data information since you might need to update the system after you replace this FRU. This update can be done through the ASMI

Power should be removed from the unit containing the FRU in the location field above. If this unit is powered on, power it off now. When the unit is completely powered off, disconnect the ac input source by removing the power cord from the unit. Do not apply power to the unit until directed to do so in this procedure.

Access the Advanced System Management Interface (ASMI). To access the ASMI, see Accessing the Advanced System Management Interface.

Record system configuration settings:

1. In the navigation area, select **System Configuration** settings > **Configure I/O Enclosures**.
  - a. Manually record the location code, rack address, unit address, power control network identifier, type-model, and serial number.

You must also power down the server connected to the 7314-G30 or feature code 5796 if the server and system firmware combination is one of the following:

- 9406-MMA or 9117-MMA with system firmware level equal to or less than EM320\_040\_031 or EM310\_069\_048.
  - 8204-E8A with system firmware level equal to or less than EL320\_040\_031.
- 

## 2. Remove the cable-management bracket

1. Label, then disconnect the ac power cords from the back of the system.
2. Remove the cable-management bracket retaining screw (A).

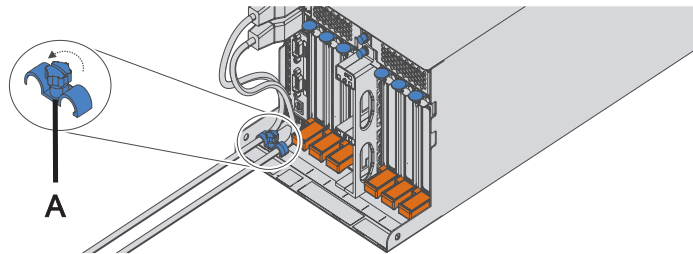

---

## 3. Remove all PCI Adapters

1. Remove both EMC Shields (if present) by pressing the tabs **(A)** while sliding them out.
2. Label, then disconnect all GX, PCI, and SPCN cables from their adapters.
3. Lift up the PCI handles **(B)** and pull the PCI adapter straight out from the PCI shuttle assembly.
4. Repeat these steps until all PCI adapters have been removed.

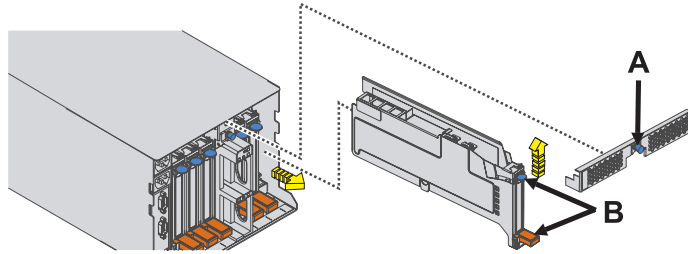

---

#### 4. Remove the power supplies

1. Rotate the power supply handle **(A)** in the direction shown to unseat the power supply.
2. Pull the power supply straight out from the I/O subsystem.
3. Repeat these steps to remove the other power supply.
4. Turn the blue thumbscrews **(B)** in the direction shown to unlock the PCI shuttle assembly.

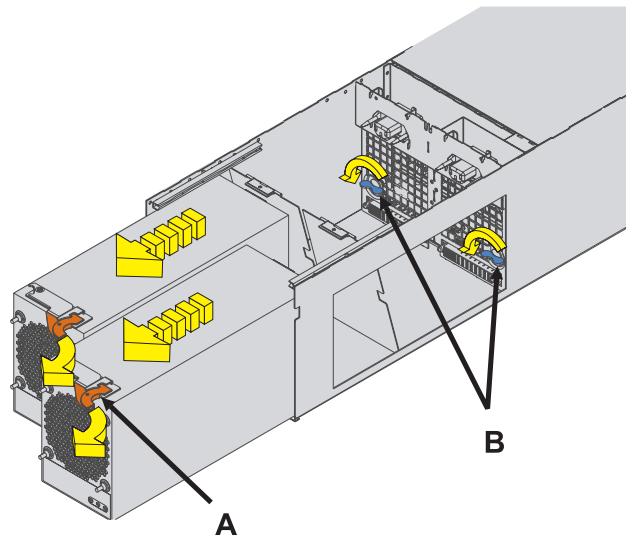

---

#### 5. Remove the PCI shuttle assembly

Slide the PCI shuttle assembly from the I/O subsystem as shown in the diagram.

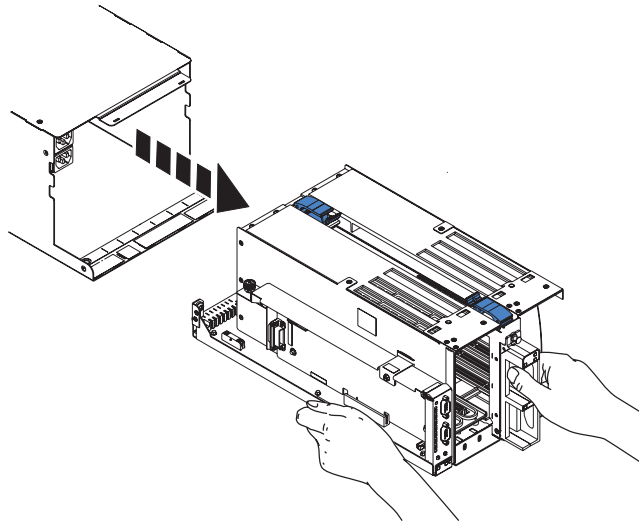

---

## 6. Remove the GX Card

1. Pull out the locking knob (A) and remove the front GX card cover.
2. Squeeze the release latches (B) to release them from the card and rotate in the direction shown.
3. Carefully pull the card out of the slot.

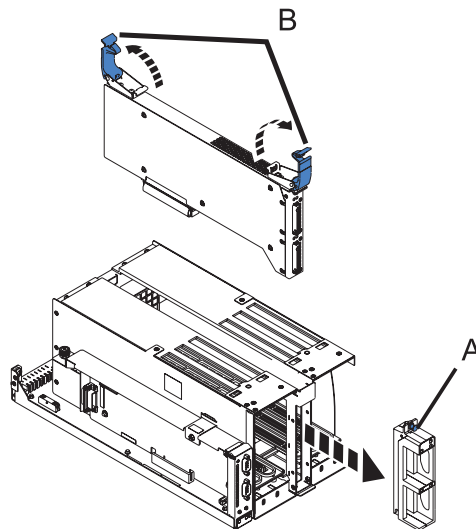

---

## 7. Remove the SPCN card

If the new PCI shuttle assembly includes a new SPCN card then go to step 10.

1. Remove the screw (A).
2. Carefully pull the SPCN card from the PCI shuttle assembly.
3. Set the failed shuttle to the side and position the new shuttle nearby, so you can reinstall the parts into the new shuttle.

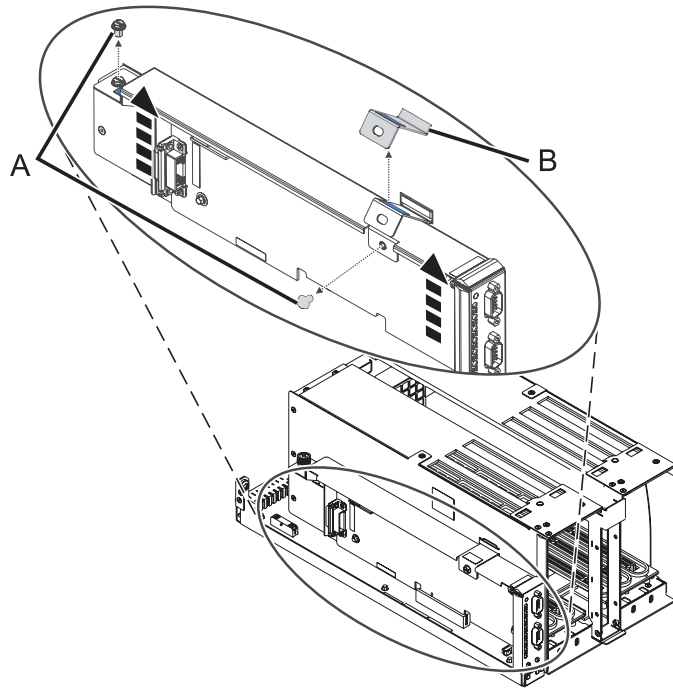

## 8. Install the SPCN card

**Note:** Discard the hold-down bracket and the screw, for installing a new SPCN card. The hold-down bracket and the screw is used for shipping the product.

1. Remove the screws (A) and (C), and then remove the clip (B).
2. Carefully install the SPCN card.
3. Tighten the screw (A).

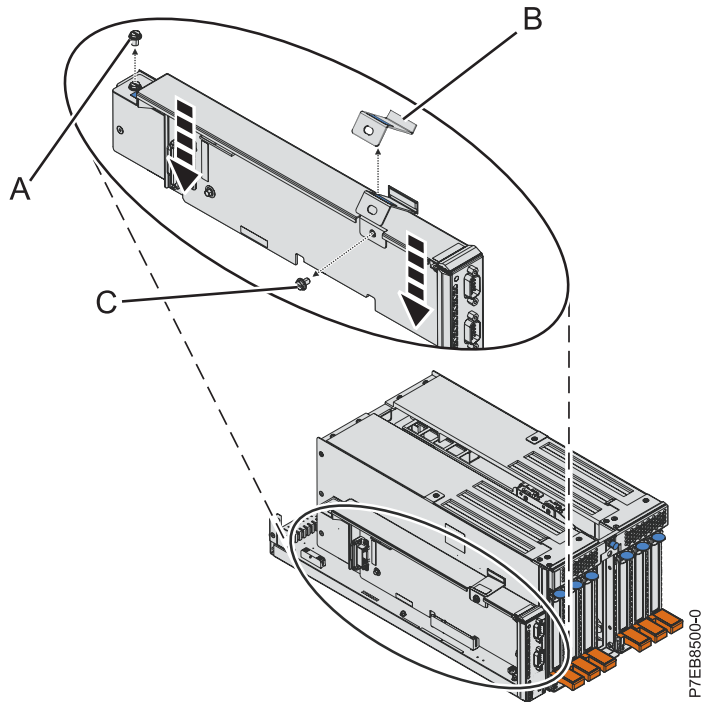

## 9. Install the GX Card in the new shuttle

1. Carefully push the card into the slot.
2. Rotate the release latches **(A)** in the direction shown, then push them down to secure the card.
3. Install the front GX card cover and push in the locking knob **(B)**.

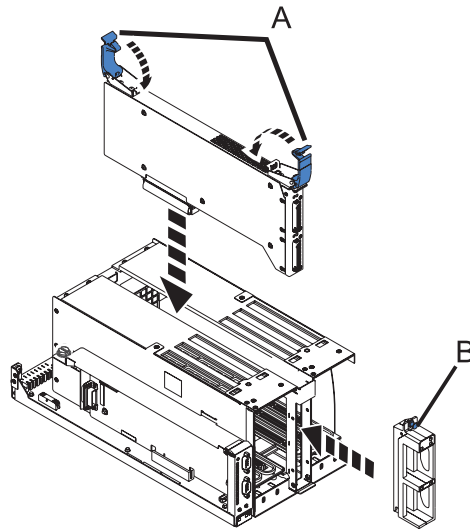

---

## 10. Install the PCI shuttle assembly

Slide the PCI shuttle assembly into the I/O subsystem.

---

## 11. Update the Vital Product Data

Perform the procedures to update the Vital Product Data (VPD) information with the machine type, model, and serial number for the management console.

1. In the navigation area, select **System Configuration** settings > **Configure I/O Enclosures**.
  - a. Select **Change settings**.
  - b. Manually check and record the location code, rack address, unit address, power control network identifier, type-model, and serial number.
  - c. Select **Save settings**.

For more information, see [Setting the system enclosure type](#).

---

## 12. Install the power supplies



1. Turn the blue thumbscrews (**A**) in the direction shown to lock the PCI shuttle assembly.
2. Push the power supply straight into the I/O subsystem.
3. Rotate the power supply handle (**B**) in the direction shown to seat the power supply.
4. Repeat the steps to install the other power supply.

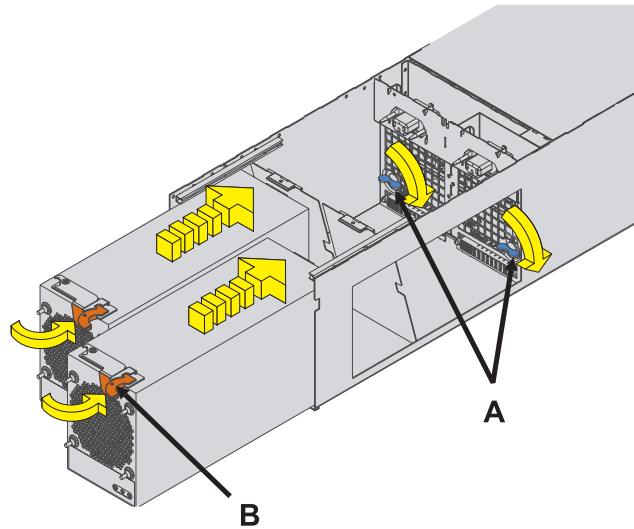

### 13. Install all PCI Adapters

1. Slide the PCI Adapter straight into its slot in the PCI shuttle assembly.
2. Push down on the PCI handles (**A**) to secure the adapter in place.
3. Repeat these steps to install the other PCI adapters.
4. Install the EMC Shields (**B**) by sliding them into their slots near the top of the shuttle assembly.
5. Reconnect all GX, PCI, and SPCN cables previously removed from their adapters.

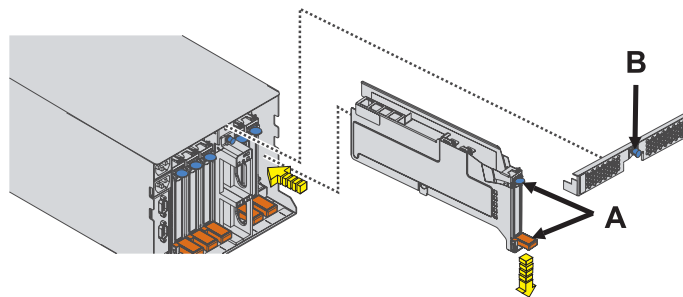

### 14. Install the cable-management bracket

1. From the back of the rack, install the cable-management bracket retaining screw (A).
2. Reconnect the ac power cords to the back of the system.

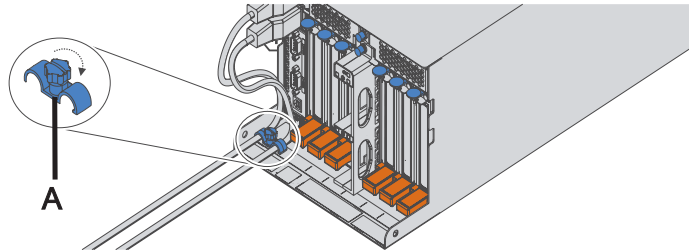

## 15. Verify the repair

Go to Verifying a repair.

## Power supply

Use this procedure to service the power supply.

### 1. Determine if this procedure can continue concurrently

To continue the repair concurrently, the following conditions must be true:

- A properly functioning power supply must already be installed in the system. This power supply has three LEDs, which must be set as follows:
- ac Input - on, not blinking
- dc Output - on, not blinking
- Fault/Identify - off

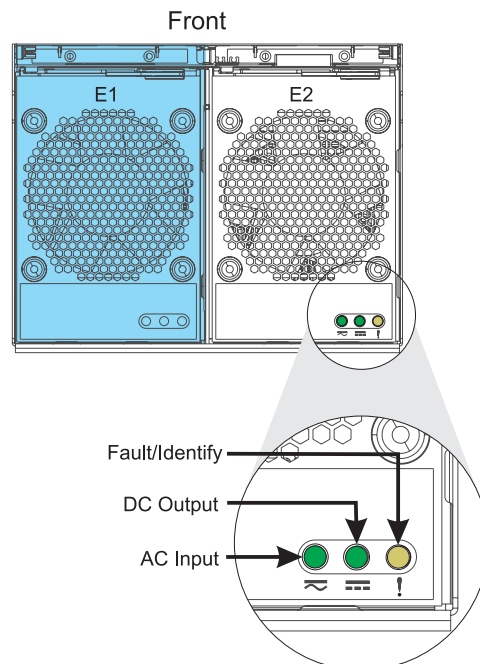

**Is there a functioning power supply meeting these conditions?**

Yes	No
↓	Go to step 4

---

**2. Determine if you are able to exchange concurrently**

**Attention:** If you are performing this procedure concurrently, from the moment the power cord is disconnected, the exchange of the power supply must be completed in *less than two minutes*. If you cannot replace the power supply in less than two minutes, the system will automatically shut down.

READ the following steps, have the replacement power supply ready, then decide if you are ready and able to continue this repair within the two-minute limit.

Remove the power supply:

Read the following steps. *Do not* perform them yet.

1. At the back of the system, disconnect the power cord that corresponds to the power supply being serviced.
2. Rotate the power supply handle (A) in the direction shown to unseat the power supply.
3. Pull the power supply straight out from the I/O subsystem.

Install the new Power Supply:

1. Push the power supply straight into the I/O subsystem.
2. Rotate the power supply handle (A) in the direction shown to seat the power supply.
3. At the back of the system, reconnect the power cord to the corresponding power supply.

**Are you ready to perform this repair in less than two minutes?**

Yes, continue concurrently	No, continue with power off	No
↓	Go to step 4	<b>This ends the procedure.</b>

---

**3.**

The power supply will be serviced concurrently. The unit will stay powered on while the power cord that corresponds to the power supply is removed. The unit can only run for a couple minutes with one power supply. Do not remove the power cord until instructed to do so.

Go to step 7 - Concurrent.

---

**4.**

The procedure can only be performed with power off.

**Select an action**

Non-concurrent repair.  
Power off the unit and continue the repair.

↓	<b>This ends the procedure.</b>
---	---------------------------------

---

**5.**

1. Rotate the power supply handle (A) in the direction shown to unseat the power supply.
2. Pull the power supply straight out from the I/O subsystem.
3. Repeat these steps to remove the other power supply.
4. Turn the blue thumbscrews (B) in the direction shown to unlock the PCI shuttle assembly.

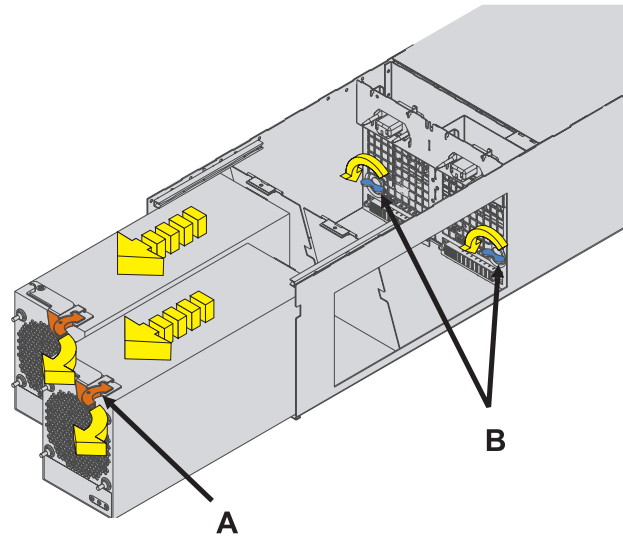

---

6.

Are you performing a miscellaneous equipment specification (MES) install operation?

Yes

No

↓

Go to step 7

---

## 7. Remove the Power Supply

Non-concurrent

1. Rotate the power supply handle (A) in the direction shown to unseat the power supply.
2. Pull the power supply straight out from the I/O subsystem.
3. Repeat these steps to remove the other power supply.
4. Turn the blue thumbscrews (B) in the direction shown to unlock the PCI shuttle assembly.

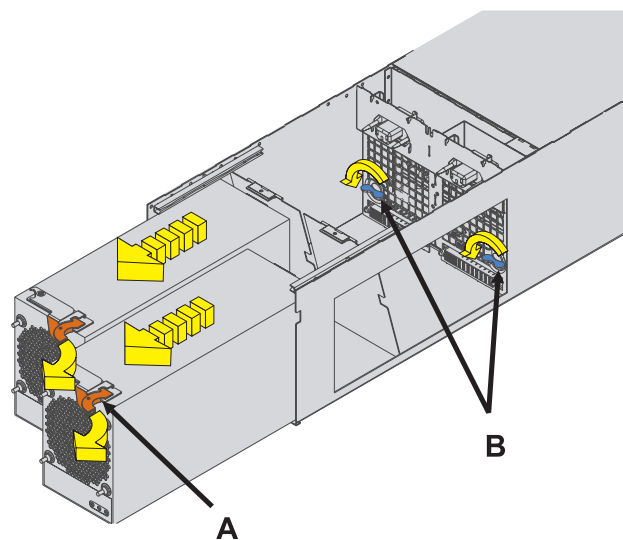

## Concurrent

1. At the back of the system, disconnect the power cord that corresponds to the power supply being serviced. This action begins the two-minute time limit to exchange the power supply.
2. Rotate the power supply handle (A) in the direction shown to unseat the power supply.
3. Pull the power supply straight out from the I/O subsystem.

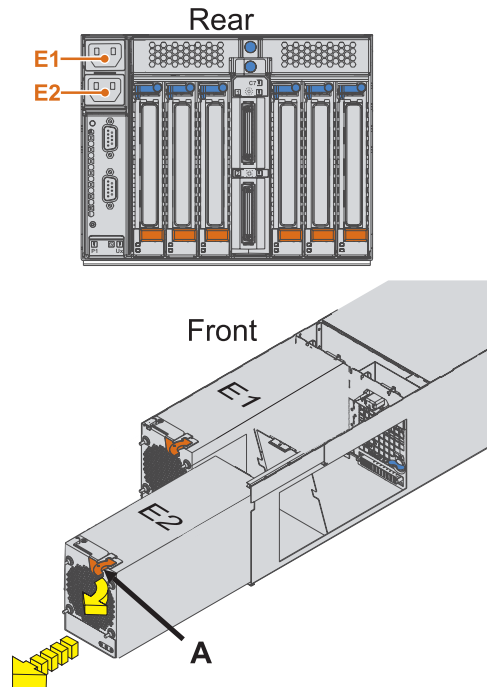

## 8. Exchange the Power Supply

1. At the back of the system, disconnect the power cord that corresponds to the power supply being serviced. This begins the two-minute time limit to exchange the power supply concurrently.
2. Rotate the power supply handle (A) in the direction shown to unseat the power supply.
3. Pull the power supply straight out from the I/O subsystem.
4. Push the replacement power supply straight into the I/O subsystem.
5. Rotate the power supply handle (B) in the direction shown to seat the power supply.
6. At the back of the system, reconnect the power cord to the corresponding power supply. This action ends the two-minute time limit to exchange the power supply concurrently.

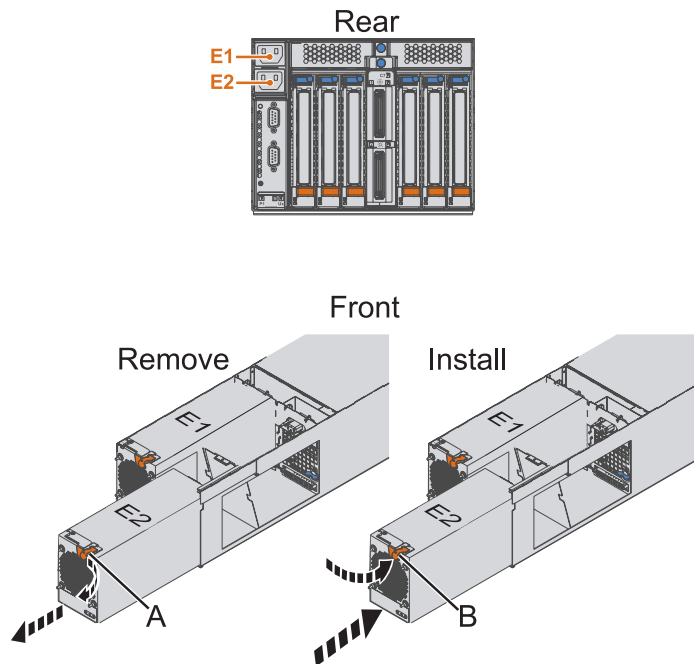

## 9. Install the Power Supply

1. Push the power supply straight into the I/O subsystem.
2. Rotate the power supply handle (A) in the direction shown to seat the power supply.
3. At the back of the system, reconnect the power cord to the corresponding power supply.

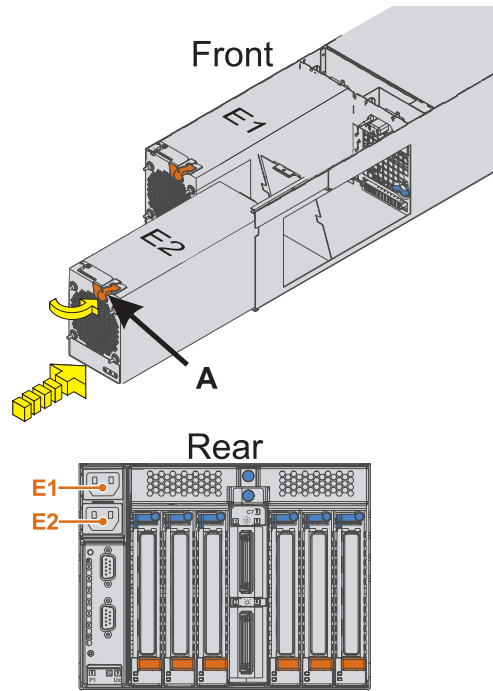

---

## 10. Verify the repair

Go to Verifying a repair.

---

## SPCN card

Use this procedure to service the system power control network (SPCN) card.

1.

This unit will be serviced nonconcurrently.

Power should be removed from the unit containing the FRU in the location field above. If this unit is powered on, power it off now. When the unit is completely powered off, disconnect the ac input source by removing the power cord from the unit. Do not apply power to the unit until directed to do so in this procedure.

---

2. **Remove the cable-management bracket**

1. Label, then disconnect the ac power cords from the back of the system.
2. Remove the cable-management bracket retaining screw (A).

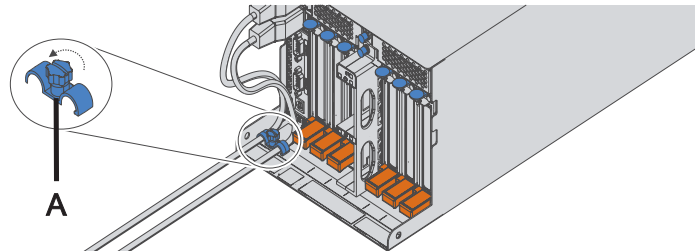

---

### 3. Remove the power supplies

1. Rotate the power supply handle (A) in the direction shown to unseat the power supply.
2. Pull the power supply straight out from the I/O subsystem.
3. Repeat these steps to remove the other power supply.
4. Turn the blue thumbscrews (B) in the direction shown to unlock the PCI shuttle assembly.

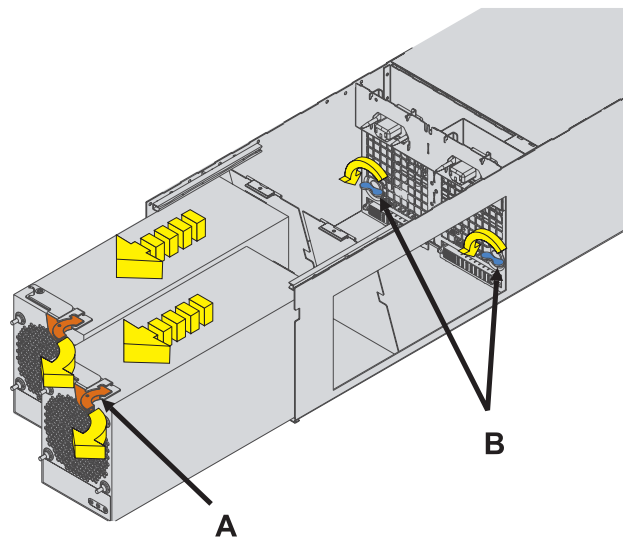

---

### 4. Remove the PCI shuttle assembly

1. Label, then disconnect all GX, PCI, and SPCN cables from their adapters.
2. Slide the PCI shuttle assembly from the I/O subsystem as shown in the diagram.

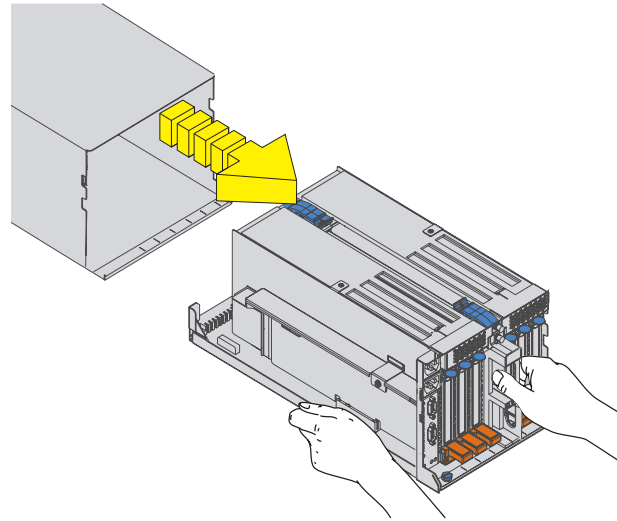

---

### 5. Remove the SPCN card

1. Remove the screw (A).
2. Carefully pull the SPCN card from the PCI shuttle assembly, retaining clip (B) by lifting it, as shown in the figure.

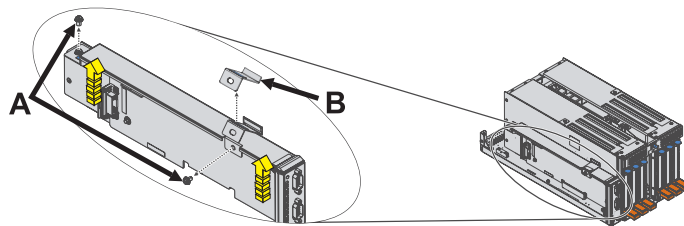

---

### 6. Install the SPCN card



1. Carefully push the SPCN card into its slot in the PCI shuttle assembly.
2. Install the screw (B).
3. Reinstall the SPCN card retaining clip (A) by pushing it down, as shown in the figure.

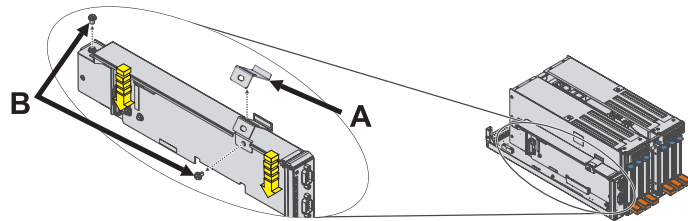

---

## 7. Install the PCI shuttle assembly

1. Slide the PCI shuttle assembly into the I/O subsystem as shown in the diagram.
2. Connect all GX, PCI, and SPCN cables that were previously removed from their adapters.

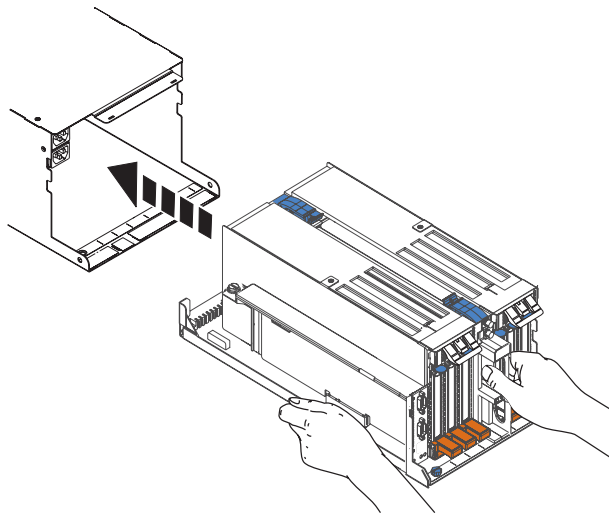

---

## 8. Install the power supplies

1. Turn the blue thumbscrews (**A**) in the direction shown to lock the PCI shuttle assembly.
2. Push the power supply straight into the I/O subsystem.
3. Rotate the power supply handle (**B**) in the direction shown to seat the power supply.
4. Repeat the steps to install the other power supply.

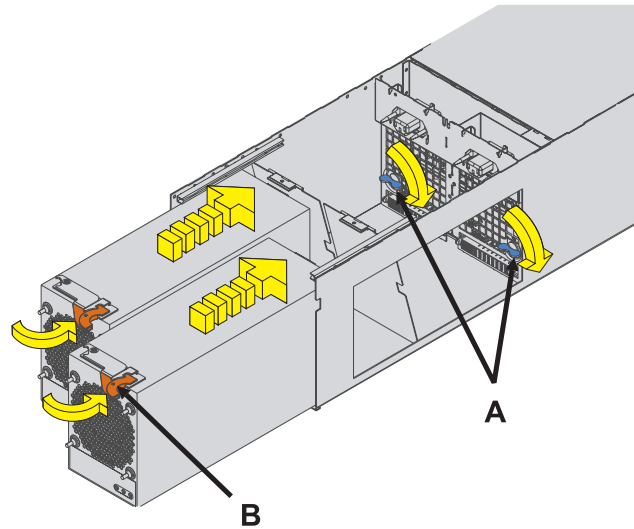

---

## 9. Install the cable-management bracket

1. From the back of the rack, install the cable-management bracket retaining screw (**A**).
2. Reconnect the ac power cords to the back of the system.

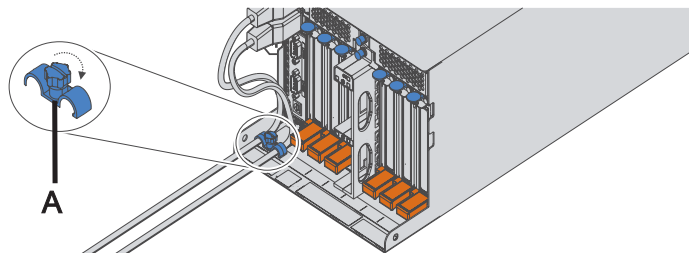

---

## 10. Verify the repair

Go to Verification Procedures.

---

---

## Notices

This information was developed for products and services offered in the U.S.A.

The manufacturer may not offer the products, services, or features discussed in this document in other countries. Consult the manufacturer's representative for information on the products and services currently available in your area. Any reference to the manufacturer's product, program, or service is not intended to state or imply that only that product, program, or service may be used. Any functionally equivalent product, program, or service that does not infringe any intellectual property right of the manufacturer may be used instead. However, it is the user's responsibility to evaluate and verify the operation of any product, program, or service.

The manufacturer may have patents or pending patent applications covering subject matter described in this document. The furnishing of this document does not grant you any license to these patents. You can send license inquiries, in writing, to the manufacturer.

**The following paragraph does not apply to the United Kingdom or any other country where such provisions are inconsistent with local law:** THIS PUBLICATION IS PROVIDED "AS IS" WITHOUT WARRANTY OF ANY KIND, EITHER EXPRESS OR IMPLIED, INCLUDING, BUT NOT LIMITED TO, THE IMPLIED WARRANTIES OF NON-INFRINGEMENT, MERCHANTABILITY OR FITNESS FOR A PARTICULAR PURPOSE. Some states do not allow disclaimer of express or implied warranties in certain transactions, therefore, this statement may not apply to you.

This information could include technical inaccuracies or typographical errors. Changes are periodically made to the information herein; these changes will be incorporated in new editions of the publication. The manufacturer may make improvements and/or changes in the product(s) and/or the program(s) described in this publication at any time without notice.

Any references in this information to websites not owned by the manufacturer are provided for convenience only and do not in any manner serve as an endorsement of those websites. The materials at those websites are not part of the materials for this product and use of those websites is at your own risk.

The manufacturer may use or distribute any of the information you supply in any way it believes appropriate without incurring any obligation to you.

Any performance data contained herein was determined in a controlled environment. Therefore, the results obtained in other operating environments may vary significantly. Some measurements may have been made on development-level systems and there is no guarantee that these measurements will be the same on generally available systems. Furthermore, some measurements may have been estimated through extrapolation. Actual results may vary. Users of this document should verify the applicable data for their specific environment.

Information concerning products not produced by this manufacturer was obtained from the suppliers of those products, their published announcements or other publicly available sources. This manufacturer has not tested those products and cannot confirm the accuracy of performance, compatibility or any other claims related to products not produced by this manufacturer. Questions on the capabilities of products not produced by this manufacturer should be addressed to the suppliers of those products.

All statements regarding the manufacturer's future direction or intent are subject to change or withdrawal without notice, and represent goals and objectives only.

The manufacturer's prices shown are the manufacturer's suggested retail prices, are current and are subject to change without notice. Dealer prices may vary.

This information is for planning purposes only. The information herein is subject to change before the products described become available.

This information contains examples of data and reports used in daily business operations. To illustrate them as completely as possible, the examples include the names of individuals, companies, brands, and products. All of these names are fictitious and any similarity to the names and addresses used by an actual business enterprise is entirely coincidental.

If you are viewing this information in softcopy, the photographs and color illustrations may not appear.

The drawings and specifications contained herein shall not be reproduced in whole or in part without the written permission of the manufacturer.

The manufacturer has prepared this information for use with the specific machines indicated. The manufacturer makes no representations that it is suitable for any other purpose.

The manufacturer's computer systems contain mechanisms designed to reduce the possibility of undetected data corruption or loss. This risk, however, cannot be eliminated. Users who experience unplanned outages, system failures, power fluctuations or outages, or component failures must verify the accuracy of operations performed and data saved or transmitted by the system at or near the time of the outage or failure. In addition, users must establish procedures to ensure that there is independent data verification before relying on such data in sensitive or critical operations. Users should periodically check the manufacturer's support websites for updated information and fixes applicable to the system and related software.

## Homologation statement

This product may not be certified in your country for connection by any means whatsoever to interfaces of public telecommunications networks. Further certification may be required by law prior to making any such connection. Contact an IBM representative or reseller for any questions.

---

## Trademarks

IBM, the IBM logo, and [ibm.com](http://ibm.com) are trademarks or registered trademarks of International Business Machines Corp., registered in many jurisdictions worldwide. Other product and service names might be trademarks of IBM or other companies. A current list of IBM trademarks is available on the web at Copyright and trademark information at [www.ibm.com/legal/copytrade.shtml](http://www.ibm.com/legal/copytrade.shtml).

Linux is a registered trademark of Linus Torvalds in the United States, other countries, or both.

---

## Electronic emission notices

When attaching a monitor to the equipment, you must use the designated monitor cable and any interference suppression devices supplied with the monitor.

## Class A Notices

The following Class A statements apply to the IBM servers that contain the POWER7<sup>®</sup> processor and its features unless designated as electromagnetic compatibility (EMC) Class B in the feature information.

## Federal Communications Commission (FCC) statement

**Note:** This equipment has been tested and found to comply with the limits for a Class A digital device, pursuant to Part 15 of the FCC Rules. These limits are designed to provide reasonable protection against harmful interference when the equipment is operated in a commercial environment. This equipment generates, uses, and can radiate radio frequency energy and, if not installed and used in accordance with

the instruction manual, may cause harmful interference to radio communications. Operation of this equipment in a residential area is likely to cause harmful interference, in which case the user will be required to correct the interference at his own expense.

Properly shielded and grounded cables and connectors must be used in order to meet FCC emission limits. IBM is not responsible for any radio or television interference caused by using other than recommended cables and connectors or by unauthorized changes or modifications to this equipment. Unauthorized changes or modifications could void the user's authority to operate the equipment.

This device complies with Part 15 of the FCC rules. Operation is subject to the following two conditions: (1) this device may not cause harmful interference, and (2) this device must accept any interference received, including interference that may cause undesired operation.

### **Industry Canada Compliance Statement**

This Class A digital apparatus complies with Canadian ICES-003.

### **Avis de conformité à la réglementation d'Industrie Canada**

Cet appareil numérique de la classe A est conforme à la norme NMB-003 du Canada.

### **European Community Compliance Statement**

This product is in conformity with the protection requirements of EU Council Directive 2004/108/EC on the approximation of the laws of the Member States relating to electromagnetic compatibility. IBM cannot accept responsibility for any failure to satisfy the protection requirements resulting from a non-recommended modification of the product, including the fitting of non-IBM option cards.

This product has been tested and found to comply with the limits for Class A Information Technology Equipment according to European Standard EN 55022. The limits for Class A equipment were derived for commercial and industrial environments to provide reasonable protection against interference with licensed communication equipment.

European Community contact:  
IBM Deutschland GmbH  
Technical Regulations, Department M372  
IBM-Allee 1, 71139 Ehningen, Germany  
Tele: +49 7032 15 2941  
email: lugi@de.ibm.com

**Warning:** This is a Class A product. In a domestic environment, this product may cause radio interference, in which case the user may be required to take adequate measures.

### **VCCI Statement - Japan**

この装置は、クラスA 情報技術装置です。この装置を家庭環境で使用すると電波妨害を引き起こすことがあります。この場合には使用者が適切な対策を講ずるよう要求されることがあります。

VCCI-A

The following is a summary of the VCCI Japanese statement in the box above:

This is a Class A product based on the standard of the VCCI Council. If this equipment is used in a domestic environment, radio interference may occur, in which case, the user may be required to take corrective actions.

### **Japanese Electronics and Information Technology Industries Association (JEITA) Confirmed Harmonics Guideline (products less than or equal to 20 A per phase)**

高調波ガイドライン適合品

### **Japanese Electronics and Information Technology Industries Association (JEITA) Confirmed Harmonics Guideline with Modifications (products greater than 20 A per phase)**

高調波ガイドライン準用品

### **Electromagnetic Interference (EMI) Statement - People's Republic of China**

#### **声 明**

此为 A 级产品,在生活环境中,  
该产品可能会造成无线电干扰。  
在这种情况下,可能需要用户对其  
干扰采取切实可行的措施。

Declaration: This is a Class A product. In a domestic environment this product may cause radio interference in which case the user may need to perform practical action.

### **Electromagnetic Interference (EMI) Statement - Taiwan**

#### **警告使用者：**

這是甲類的資訊產品，在  
居住的環境中使用時，可  
能會造成射頻干擾，在這  
種情況下，使用者會被要  
求採取某些適當的對策。

The following is a summary of the EMI Taiwan statement above.

Warning: This is a Class A product. In a domestic environment this product may cause radio interference in which case the user will be required to take adequate measures.

**IBM Taiwan Contact Information:**

台灣IBM 產品服務聯絡方式：  
台灣國際商業機器股份有限公司  
台北市松仁路7號3樓  
電話：0800-016-888

### **Electromagnetic Interference (EMI) Statement - Korea**

이 기기는 업무용(A급)으로 전자파적합기기로서 판매자 또는 사용자는 이 점을 주의하시기 바라며, 가정외의 지역에서 사용하는 것을 목적으로 합니다.

### **Germany Compliance Statement**

#### **Deutschsprachiger EU Hinweis: Hinweis für Geräte der Klasse A EU-Richtlinie zur Elektromagnetischen Verträglichkeit**

Dieses Produkt entspricht den Schutzanforderungen der EU-Richtlinie 2004/108/EG zur Angleichung der Rechtsvorschriften über die elektromagnetische Verträglichkeit in den EU-Mitgliedsstaaten und hält die Grenzwerte der EN 55022 Klasse A ein.

Um dieses sicherzustellen, sind die Geräte wie in den Handbüchern beschrieben zu installieren und zu betreiben. Des Weiteren dürfen auch nur von der IBM empfohlene Kabel angeschlossen werden. IBM übernimmt keine Verantwortung für die Einhaltung der Schutzanforderungen, wenn das Produkt ohne Zustimmung von IBM verändert bzw. wenn Erweiterungskomponenten von Fremdherstellern ohne Empfehlung von IBM gesteckt/eingebaut werden.

EN 55022 Klasse A Geräte müssen mit folgendem Warnhinweis versehen werden:

"Warnung: Dieses ist eine Einrichtung der Klasse A. Diese Einrichtung kann im Wohnbereich Funk-Störungen verursachen; in diesem Fall kann vom Betreiber verlangt werden, angemessene Maßnahmen zu ergreifen und dafür aufzukommen."

#### **Deutschland: Einhaltung des Gesetzes über die elektromagnetische Verträglichkeit von Geräten**

Dieses Produkt entspricht dem "Gesetz über die elektromagnetische Verträglichkeit von Geräten (EMVG)". Dies ist die Umsetzung der EU-Richtlinie 2004/108/EG in der Bundesrepublik Deutschland.

#### **Zulassungsbescheinigung laut dem Deutschen Gesetz über die elektromagnetische Verträglichkeit von Geräten (EMVG) (bzw. der EMC EG Richtlinie 2004/108/EG) für Geräte der Klasse A**

Dieses Gerät ist berechtigt, in Übereinstimmung mit dem Deutschen EMVG das EG-Konformitätszeichen - CE - zu führen.

Verantwortlich für die Einhaltung der EMV Vorschriften ist der Hersteller:  
International Business Machines Corp.  
New Orchard Road  
Armonk, New York 10504  
Tel: 914-499-1900

Der verantwortliche Ansprechpartner des Herstellers in der EU ist:  
IBM Deutschland GmbH  
Technical Regulations, Abteilung M372  
IBM-Allee 1, 71139 Ehningen, Germany  
Tel: +49 7032 15 2941  
email: lugi@de.ibm.com

Generelle Informationen:

Das Gerät erfüllt die Schutzanforderungen nach EN 55024 und EN 55022 Klasse A.

### **Electromagnetic Interference (EMI) Statement - Russia**

**ВНИМАНИЕ!** Настоящее изделие относится к классу А.  
В жилых помещениях оно может создавать  
радиопомехи, для снижения которых необходимы  
дополнительные меры

---

## **Terms and conditions**

Permissions for the use of these publications are granted subject to the following terms and conditions.

**Applicability:** These terms and conditions are in addition to any terms of use for the IBM website.

**Personal Use:** You may reproduce these publications for your personal, noncommercial use provided that all proprietary notices are preserved. You may not distribute, display or make derivative works of these publications, or any portion thereof, without the express consent of IBM.

**Commercial Use:** You may reproduce, distribute and display these publications solely within your enterprise provided that all proprietary notices are preserved. You may not make derivative works of these publications, or reproduce, distribute or display these publications or any portion thereof outside your enterprise, without the express consent of IBM.

**Rights:** Except as expressly granted in this permission, no other permissions, licenses or rights are granted, either express or implied, to the Publications or any information, data, software or other intellectual property contained therein.

IBM reserves the right to withdraw the permissions granted herein whenever, in its discretion, the use of the publications is detrimental to its interest or, as determined by IBM, the above instructions are not being properly followed.

You may not download, export or re-export this information except in full compliance with all applicable laws and regulations, including all United States export laws and regulations.

IBM MAKES NO GUARANTEE ABOUT THE CONTENT OF THESE PUBLICATIONS. THE PUBLICATIONS ARE PROVIDED "AS-IS" AND WITHOUT WARRANTY OF ANY KIND, EITHER



EXPRESSED OR IMPLIED, INCLUDING BUT NOT LIMITED TO IMPLIED WARRANTIES OF MERCHANTABILITY, NON-INFRINGEMENT, AND FITNESS FOR A PARTICULAR PURPOSE.







Printed in USA