

Power775

Disk Enclosure Rails Service Procedure

Last Modified 11/03/2011

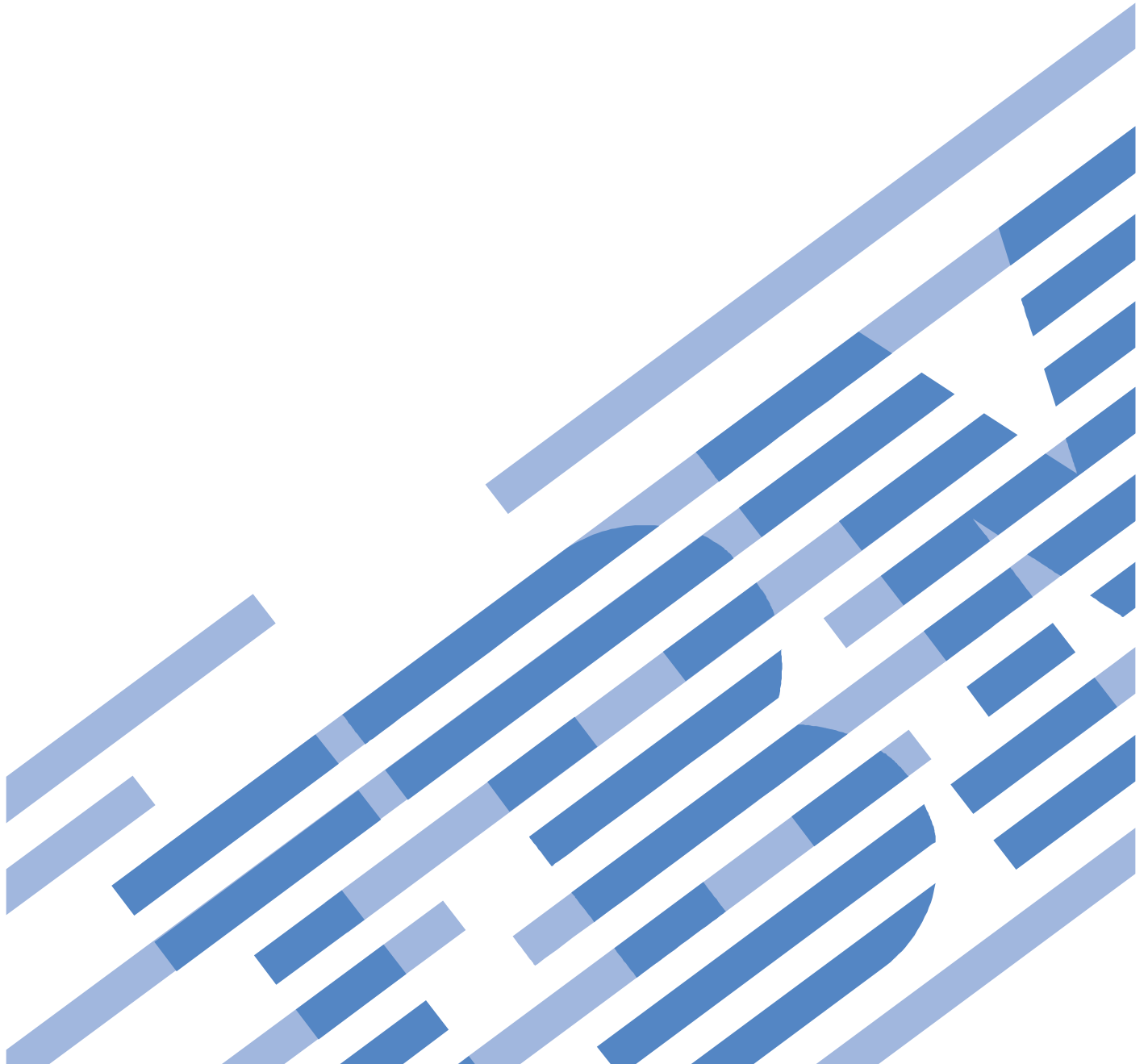

Power775 Disk Enclosure Rail Service Procedure

CONTENTS

1	GENERAL	5
1.1	RELEASE / REVISION HISTORY	5
1.2	WHERE TO FIND THIS DOCUMENT	5
1.3	REQUIRED DOCUMENTS	5
1.4	RELATED DOCUMENTS	5
1.5	ABBREVIATIONS	6
2	OVERVIEW	7
2.1	SAFETY NOTICES	7
2.2	ATTENTION: FILE SYSTEM RISK STATEMENT	9
2.3	CONFIRM HOW YOU GOT TO THIS POWER775 DISK ENCLOSURE RAIL SERVICE PROCEDURE	9
2.4	DE RAILS DESCRIPTION	9
2.4.1	Enclosure VPD label and Location Code	12
2.5	CONCURRENCY	12
2.6	DE RAIL WEIGHT	12
2.7	REQUIRED SSRS AND ROLES	12
2.8	ESTIMATED SERVICE TIME	13
2.9	REQUIRED TOOLS	13
2.10	PREREQUISITES FOR THIS PROCEDURE	13
2.11	SERVICE PROCEDURE OVERVIEW	13
3	SERVICE PROCEDURE	14
3.1	ASSESS SHUTDOWN OF FILE SYSTEM <= CUSTOMER TASK	14
3.2	SHUT DOWN THE FILE SYSTEM <= CUSTOMER TASK	14
3.3	IDENTIFY THE FRAME <= SSR TASK	15
3.4	POWER OFF THE DISK ENCLOSURE <= CUSTOMER TASK	22
3.5	CONFIRM THAT 350V IS OFF TO THE DISK ENCLOSURE <= SSR TASK	22
3.6	REMOVE FRONT DOOR AND LATCH PLATE, MOVE UEPO PANEL <= SSR TASK	24
3.7	DISCONNECT CABLES, HOSES, AND RETENTION SCREWS <= SSR TASK	29
3.8	ATTACH THE LIFT TOOL TO THE FRAME <= SSR TASK	36
3.9	MOVE THE DISK ENCLOSURE ONTO THE LIFT TOOL <= SSR TASK	41
3.10	REMOVE DEFECTIVE DE RAILS <= SSR TASK	47
3.11	INSTALL NEW DE RAILS <= SSR TASK	48
3.12	INSTALL DE BACK INTO FRAME <= SSR TASK	50
3.13	STORE ALL TOOLS. <= SSR TASK	52
3.14	POWER ON THE DISK ENCLOSURE <= CUSTOMER TASK	52
3.15	CONFIRM WITH THE CUSTOMER <= SSR TASK	53
4	END OF POWER775 DISK ENCLOSURE RAILS SERVICE PROCEDURE	54
5	APPENDIX A: POWER775 BPC FSP COMMAND LINE PROCEDURE	55
5.1	PROCEDURE TO ACCESS THE BPC FSP COMMAND LINE	55
5.2	END OF APPENDIX A: POWER775 BPC FSP COMMAND LINE PROCEDURE	57

Figure List

Figure 1: DE Rail Assembly Front & Back Views	9
Figure 2: Typical 12-Node, 1-DE Rack Configuration	10
Figure 3: Typical 2-Node, 6-DE Rack Configuration	11
Figure 4: DE Enclosure VPD Label Location	12
Figure 5 Disk Enclosure HEX Cage ID	16
Figure 6 Frame Photo showing UEPO location.....	17
Figure 7 UEPO assembly showing frame Identify Amber LED.....	18
Figure 8 Door Latch	19
Figure 9 Door Latch handle shown extended.....	19
Figure 10 The Front Enclosure ID LED is located on the DE DCCAs.....	20
Figure 11 Rear Enclosure ID LED is located on the bottom right side of the DE	21
Figure 12: T1 and T4 Input Power LEDs on the DE DCCAs.....	23
Figure 13 Removal of Front Door	24
Figure 14 Door Hinge Pin.....	24
Figure 15: Disk Enclosure and UEPO Location Info.....	25
Figure 16: Frame UEPO Service Position.....	26
Figure 17: Disk Enclosure and Door Latch Plate Location Info.....	27
Figure 18: Door Latch Plate Screw Location	27
Figure 19: Door Latch Plate Removal	28
Figure 20: DCCA Service Network Communications (E/NET) Cable	29
Figure 21 DE cabling.....	29
Figure 22: Disk Enclosure DCCA Power Cables (HPIC)	30
Figure 23: Disk Enclosure Port Card Cabling	31
Figure 24 Photo of Front Rail Block Captive Screw	32
Figure 25: Front Rail Block Screws.....	33
Figure 26 Water Hose Connector	34
Figure 27: Disk Enclosure Rear Rail Block Captive Screws.....	35
Figure 28 Lift Tool attachment Bracket.....	36
Figure 29 Lift Tool Anchor Holes	36
Figure 30: Lift Tool against Front Side of Frame.....	37
Figure 31 Lift Tool attached to frame.....	37
Figure 32: Front Table Stop	38
Figure 33: Lift Table Movement Path.....	38
Figure 34: Secure Cables	39
Figure 35 Power Drill Operation – Correct Technique.....	39
Figure 36 Power Drill Operation – Correct Settings for Use.....	40
Figure 37 Relocate the DCCA cables	42
Figure 38 Cable Protector Sheet.....	42
Figure 39 Fold Cable Protector Sheet.....	42
Figure 40 Cable protector sheet shown in upper left position	43
Figure 41 Blue-purple Recessed Touch Points.....	43
Figure 42 Front of DE resting on lift tool	44
Figure 43 DE slid out slowly to point of latch engagement	44
Figure 44 Disengage the right latch first.....	45
Figure 45 Side view of latching system of DE out of frame	45
Figure 46 DE removed from frame.....	46
Figure 47 DE supported by Lift Tool and cage stop bracket.....	46
Figure 48: Disk Enclosure Drawer Rail Mounting Screws.....	47
Figure 49: Disk Enclosure Drawer Rails.....	47
Figure 50: Rack Key Slot Locations	48
Figure 51: Align Mushroom Pins in Rack.....	48
Figure 52: Rack Outer Side View of Installed Rail	49
Figure 53: Rail Block Rail Block Interfering with Drive Carrier	51
Figure 54: Rail Block Correctly Installed	51

Power775 Disk Enclosure Rail Service Procedure

Table List

Table 1: Release / Revision History.....	5
Table 2: Required Documents.....	5
Table 3: Related Documents.....	5
Table 4: Abbreviations.....	6

1 GENERAL

1.1 Release / Revision History

File Name	Date	Description
"p775_de_rails.pdf"	11/03/2011	Initial Release

Table 1: Release / Revision History

1.2 Where to find this document

The current "Power775 Disk Enclosure Rail Service Procedure" document is "p775_de_rails.pdf" which is to be downloaded from: InfoCenter Website: <http://publib.boulder.ibm.com/infocenter/powersys/v3r1m5/topic/p7ee2/p7ee2kickoff.htm>

Click "PDF files for the IBM Power 775 (9125-F2C) removing and replacing parts"

Under "Disk Enclosure", click "Disk Enclosure Rails" to download PDF "p775_de_rails.pdf"

This is the only valid source for the latest Power775 Disk Enclosure Rails Service Procedure.

1.3 Required Documents

Document	P/N	Location
Safety Notices http://publib.boulder.ibm.com/infocenter/powersys/v3r1m5/topic/p7hdx/G229-9054.pdf	Doc# G229-9054	Infocenter*

Table 2: Required Documents

*InfoCenter Website: <http://publib.boulder.ibm.com/infocenter/powersys/v3r1m5/topic/p7ee2/p7ee2kickoff.htm>

1.4 Related Documents

Document	PN	Location
GPFS Native RAID Administration and Programming Reference	Document # SA23-1354	InfoCenter *
Power775 Disk Enclosure Fan Service Procedure		InfoCenter *

Table 3: Related Documents

*InfoCenter Website: <http://publib.boulder.ibm.com/infocenter/powersys/v3r1m5/topic/p7ee2/p7ee2kickoff.htm>

1.5 Abbreviations

Abbreviation	Definition	Details
BPA	Bulk Power Assembly	
CEC	Central Electronic Complex	Also referred to as the “node”.
DCCA	Distributed Conversion and Control Assembly	The power supplies for the CEC and DE are called the CEC DCCA and DE DCCA respectively.
DE	Disk Enclosure	
GPFS	Global Parallel File System	IBM’s file system utilizing software RAID
HDD	Hard Disk Drive	This also means hard drive
HPIC	High Power Interface Cable	DCCA power cable
LED	Light Emitting Diode	
LIC	Licensed Internal Code	
PCB	Printed Circuit Board	
RAID	Redundant Array of Inexpensive Disks	
SAS	Serial Attached SCSI	Protocol used for direct attached storage
SSR	Systems Services Representative	IBM Service personnel
SSD	Solid State Drive	
UEPO	Unit Emergency Power Off	

Table 4: Abbreviations

2 OVERVIEW

This section is an overview only. Do not start the service procedure until Section 3 which contains the detailed steps.

2.1 Safety Notices

Read “Safety_Notices “ available from InfoCenter – see Section 1.3.

<http://publib.boulder.ibm.com/infocenter/powersys/v3r1m5/topic/p7hdx/G229-9054.pdf>

The following cautions apply to all Power775 service procedures:

CAUTION:

Energy hazard present. Shorting might result in system outage and possible physical injury. Remove all metallic jewelry before servicing. (C001)

CAUTION:

The doors and covers to the product are to be closed at all times except for service by trained service personnel. All covers must be replaced and doors locked at the conclusion of the service operation. (C013)

CAUTION:

Servicing of this product or unit is to be performed by trained service personnel only. (C032)

The following notices specifically pertain to this Power775 service procedure:

DANGER: Heavy equipment — personal injury or equipment damage might result if mishandled. (D006)

CAUTION:



The weight of this part or unit is more than 55 kg (121.2 lb). It takes specially trained persons, a lifting device, or both to safely lift this part or unit. (C011)

CAUTION: Do not remove or install this unit without using the provided lift tool. (C017)

CAUTION: The water-based coolant solution may contain an additive intended to inhibit corrosion (or provide other functions). The solution may cause irritation to the skin or eyes. Avoid direct contact with the solution. Employ appropriate Personal Protective Equipment when performing operations involving the coolant or which may potentially expose you to the coolant. Refer to the MSDS for more information. (C037)

CAUTION: This unit must not be left running unattended, service personnel should always be overseeing the process. (C038)

Power775 Disk Enclosure Rail Service Procedure



DANGER: Hazardous voltage present. Voltages present constitute a shock hazard, which can cause severe injury or death. (L004)



CAUTION: Sharp edges, corners, or joints nearby. (L006)



CAUTION: System or part is heavy. The label is accompanied by a specific weight range. (L009)



CAUTION: Protective eyewear is needed for the procedure. (L011)



CAUTION: Pinch hazard. (L012)



DANGER: Heavy equipment—personal injury or equipment damage might result if mishandled. (L013)



CAUTION: Chemical resistant gloves are needed for this procedure. (L014)

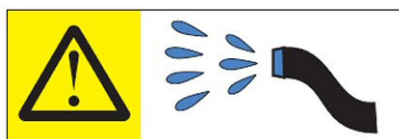

DANGER: Risk of electric shock due to water or a water solution which is present in this product. Avoid working on or near energized equipment with wet hands or when spilled water is present. (L016)

2.2 ATTENTION: File System Risk Statement

The Global Parallel File System (GPFS) implementation of software RAID stripes data across all the Disk Enclosures in the cluster. **If a single Disk Enclosure is powered off while GPFS is active, the file system will go into panic and become unavailable.**

This service procedure requires powering off a Disk Enclosure and because of this requires interaction with GPFS in order to limit impact to performance.

2.3 Confirm how you got to this Power775 Disk Enclosure Rail Service Procedure

You should be performing this procedure if you have determined a Disk Enclosure Rail has failed and needs replacement.

You should have downloaded this procedure from:

InfoCenter Website: <http://publib.boulder.ibm.com/infocenter/powersys/v3r1m5/topic/p7ee2/p7ee2kickoff.htm>

This is the only valid source for the latest Power775 Disk Enclosure Rail Service Procedure.

2.4 DE Rails Description

The Power775 Disk Enclosure is supported in the Rack on 2 rail assemblies, one on the left and one on the right of the Disk Enclosure unit. Figure 1 shows a photograph of the Rail assembly. These Rail assemblies include integrated SAS cable channels to assist in routing SAS cables from the front of the DE to the back (as shown in Figure 1 (“D”)). Disk Enclosures can be located in up to six positions in the Rack. Figure 2 shows a typical 12-Node, 1-DE configuration and Figure 3 shows a typical 2-Node, 6-DE configuration.

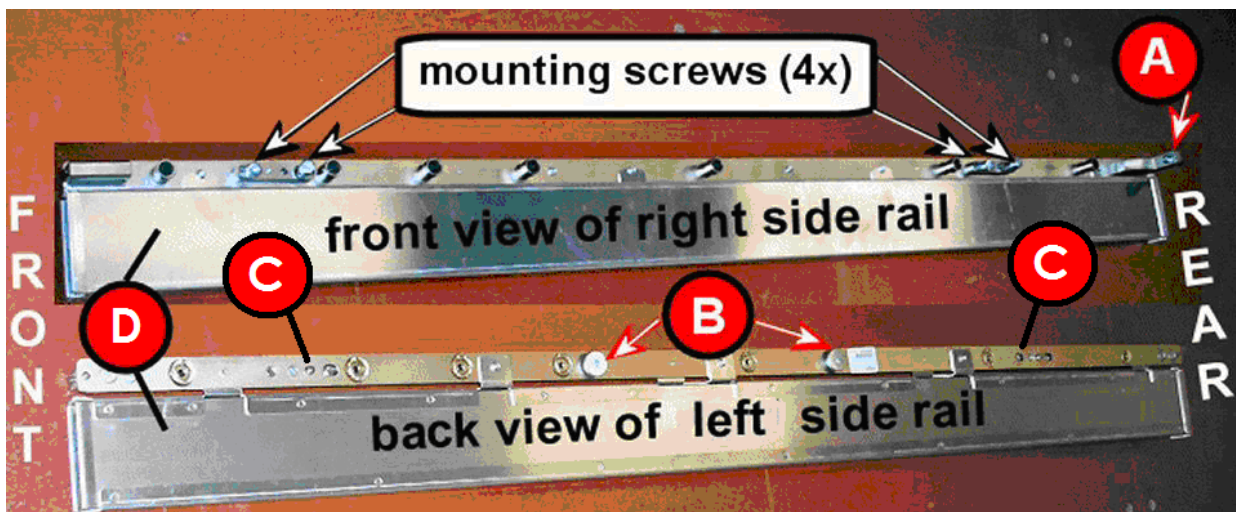

Figure 1: DE Rail Assembly Front & Back Views

Power775 Disk Enclosure Rail Service Procedure

Front View

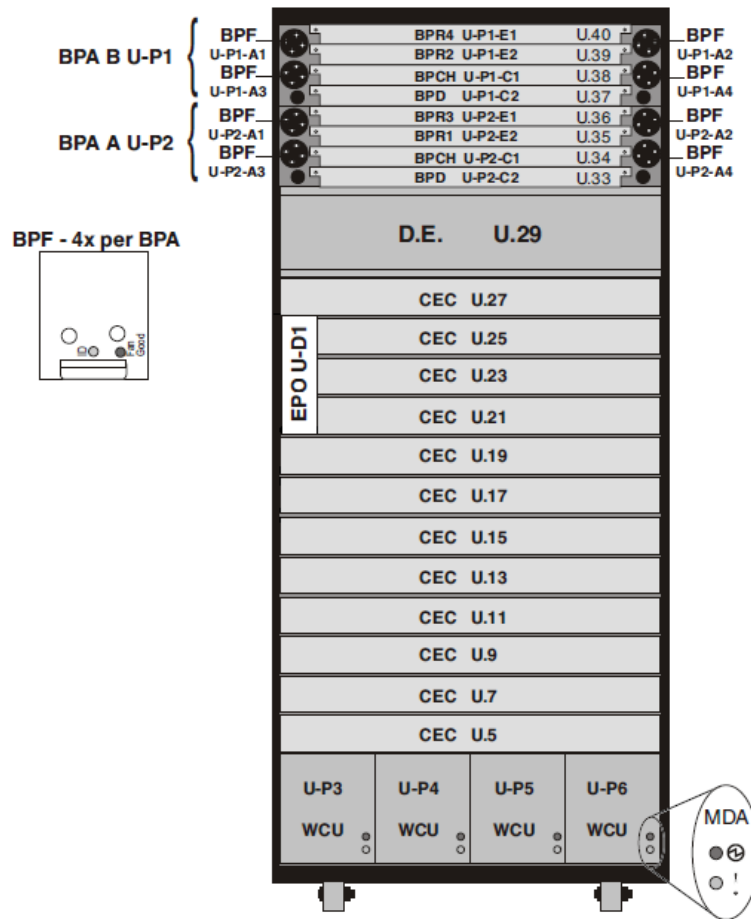

Figure 2: Typical 12-Node, 1-DE Rack Configuration

Power775 Disk Enclosure Rail Service Procedure

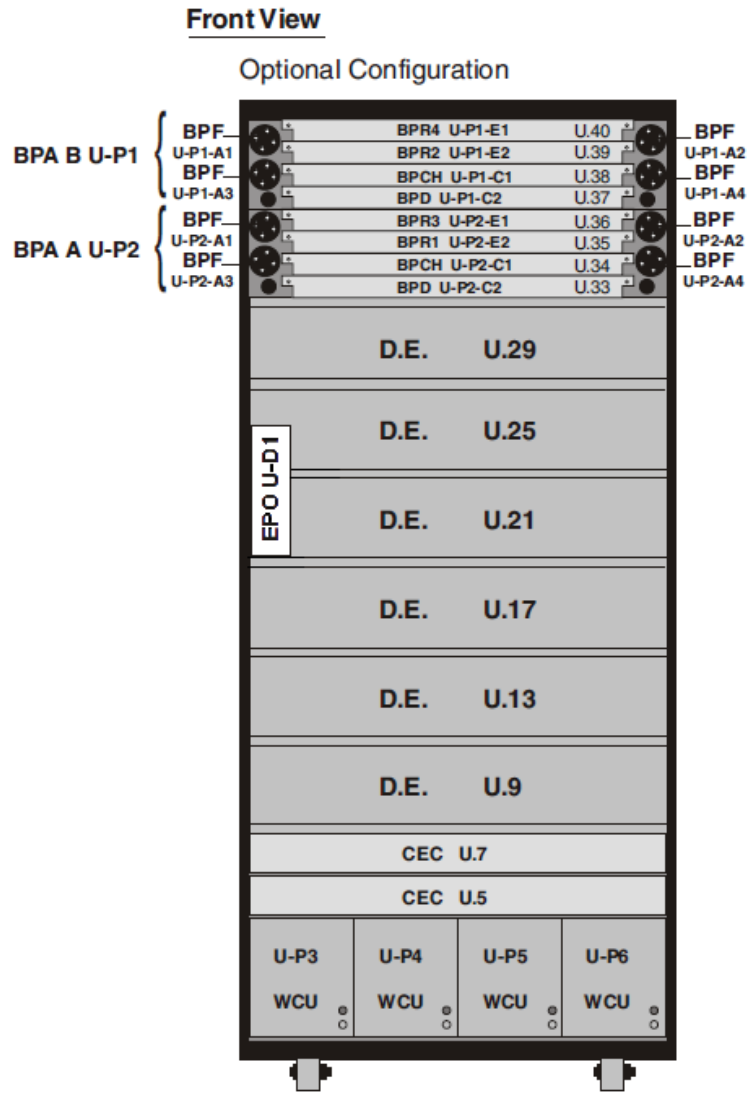

Figure 3: Typical 2-Node, 6-DE Rack Configuration

2.4.1 Enclosure VPD label and Location Code

The enclosure VPD label is placed on the rear of a Disk Enclosure just above the enclosure LEDs as shown in Figure 4.



Figure 4: DE Enclosure VPD Label Location

2.5 Concurrency

The DE Rails are NOT concurrently maintainable. This procedure requires the customer to stop all client applications and shut down the file system.

2.6 DE Rail Weight

Each DE Rail assembly weighs about 5 lbs (2.3 kg)

2.7 Required SSRs and Roles

This service procedure requires two SSRs.

This service procedure contains steps to be performed by a customer system administrator and two IBM SSRs (System Service Representatives).

- The customer system administrator performs the STEPs in Sections marked with “<= CUSTOMER TASK”
- The SSR performs the STEPs in Sections marked with “<= SSR TASK”

2.8 Estimated Service Time

The estimated service time for this procedure is about 1 hour.

2.9 Required Tools

Service card (shipped in the Power 775 frame)

Lift Tool Kit 74Y1087

- Ladder PN 46G5947 may be required for upper DE locations (shipped in the Power 775 Lift Tool Kit)

Hand Tool Kit P/N 74Y0988

- Torque Clutch P/N 74Y0985 (shipped in the Hand Tool Kit)
 - Ratchet handle P/N 6428240 (shipped in the Hand Tool Kit)
 - Extension (18") P/N 46K2707 (shipped in the Hand Tool Kit)
 - 2 mm Hex Torque Driver P/N 74Y0983 (shipped in the Hand Tool Kit)
 - 3 mm Hex Torque Driver P/N 74Y0998 (shipped in the Hand Tool Kit)
 - 4mm Hex Torque Driver PN 41V1059 (shipped in the Hand Tool Kit)
 - 5 mm Hex tool P/N 74Y0986 (shipped in the Hand Tool Kit)
 - 10 mm Socket P/N 02F3582 (shipped in the Hand Tool Kit)
-

2.10 Prerequisites for this Procedure

In order to perform this procedure, you will need the following information:

- The location code of the DE where the Rails are to be serviced.
 - The cage location of the DE where the Rails are to be serviced.
 - The frame number and frame serial number of the Rack containing the DE where the Rails are to be serviced.
-

2.11 Service Procedure Overview

This is an overview of the tasks to be performed. Read this overview but do not perform any of the tasks yet.

3.1	ASSESS SHUTDOWN OF FILE SYSTEM <= CUSTOMER TASK	14
3.2	SHUT DOWN THE FILE SYSTEM <= CUSTOMER TASK	14
3.3	IDENTIFY THE FRAME <= SSR TASK	15
3.4	POWER OFF THE DISK ENCLOSURE <= CUSTOMER TASK	22
3.5	CONFIRM THAT 350V IS OFF TO THE DISK ENCLOSURE <= SSR TASK	22
3.6	REMOVE FRONT DOOR AND LATCH PLATE, MOVE UEPO PANEL <= SSR TASK	24
3.7	DISCONNECT CABLES, HOSES, AND RETENTION SCREWS <= SSR TASK	29
3.8	ATTACH THE LIFT TOOL TO THE FRAME <= SSR TASK	36
3.9	MOVE THE DISK ENCLOSURE ONTO THE LIFT TOOL <= SSR TASK	41
3.10	REMOVE DEFECTIVE DE RAILS <= SSR TASK	47
3.11	INSTALL NEW DE RAILS <= SSR TASK	48
3.12	INSTALL DE BACK INTO FRAME <= SSR TASK	50
3.13	STORE ALL TOOLS. <= SSR TASK	52
3.14	POWER ON THE DISK ENCLOSURE <= CUSTOMER TASK	52
3.15	CONFIRM WITH THE CUSTOMER <= SSR TASK	53

3 SERVICE PROCEDURE

STOP – Do not proceed unless you have read “Safety Notices” which is available from InfoCenter; see Section 1.3.

3.1 Assess Shutdown of File System <= CUSTOMER TASK

STEP 1 The customer must assess whether all client applications can be stopped at this time and whether the Global Parallel File System (GPFS) can be shut down at this time.

This procedure requires powering off a Disk Enclosure, which under most conditions, if the file system is active, will result in putting the file system into panic and making it unavailable. While it is technically possible to drain all the data from a Disk Enclosure before shutting it down and leave the file system active for this procedure, it is assumed impractical due to the excessive time required to move all the data.

For more details, see related document “GPFS Native RAID Administration and Programming Reference”, which can be found in InfoCenter.

If all client applications can be stopped and if GPFS can be shut down, proceed to STEP 2.

If you cannot stop the applications and file system at this time, you must wait to perform this procedure until a time when the file system can be shut down. The Disk Enclosure should continue to operate as long as the Rails are not severely damaged and that all connections (water, power, comm. etc.) are still intact.

3.2 Shut Down the File System <= CUSTOMER TASK

Steps 2 through 3 are to be performed by the Customer.

STEP 2 Stop all client applications.

STEP 3 Shut down GPFS. Wait for complete shutdown before proceeding to STEP 4.

3.3 Identify the frame <= SSR TASK

- STEP 4 Use the procedure “Appendix A: Power775 BPC FSP Command Line Procedure” (included in Section 5 of this document) to access the BPC FSP command line of the frame with the Disk Enclosure needing its rails replaced.
- STEP 5 Blink the Enclosure Identify LEDs of the DE with the FRU needing replacement by using the following command from the BPC Command Line:

This is the command syntax:

```
bpccmd -c 27<blank>0000<cage ID><FRU ID><LED blink state 00=off, 02=blink>
```

<blank>	= “11”
<cage ID>	= see Figure 5
<FRU ID>	= “01” for the DE Identify LED.
<LED state>	= “02” for this step

Type in the following, inserting the correct Cage ID DE chassis location:

```
bpccmd -c 27110000xx0102
```

Where “xx” is the Cage ID of the DE you are servicing.

This field will be 05,07,09,0B,0D, or 0F (see Figure 5).

The correct return code is 001100. If you do not receive this, contact the next level of support.

Below is an example assuming Cage ID=0f

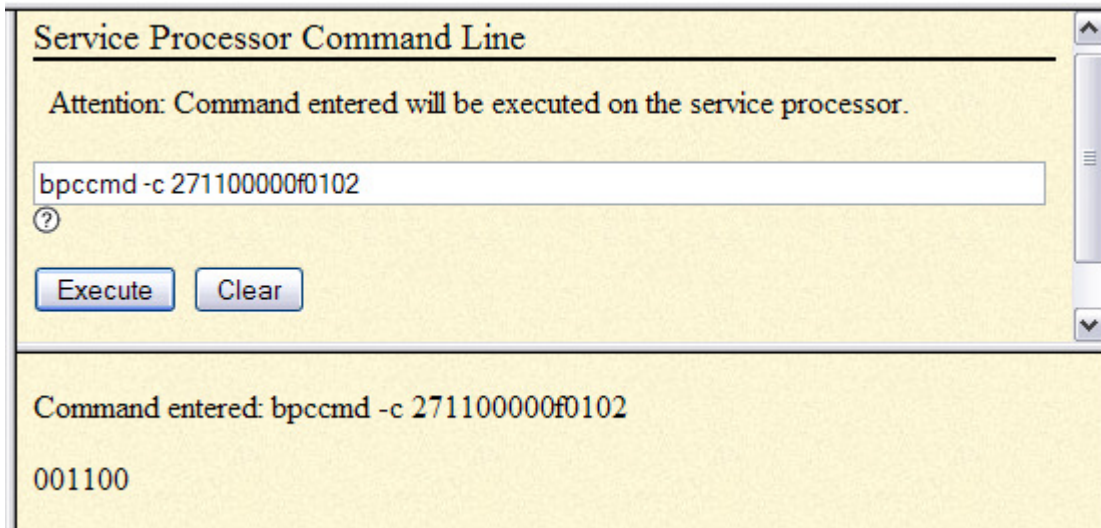

Power775 Disk Enclosure Rail Service Procedure

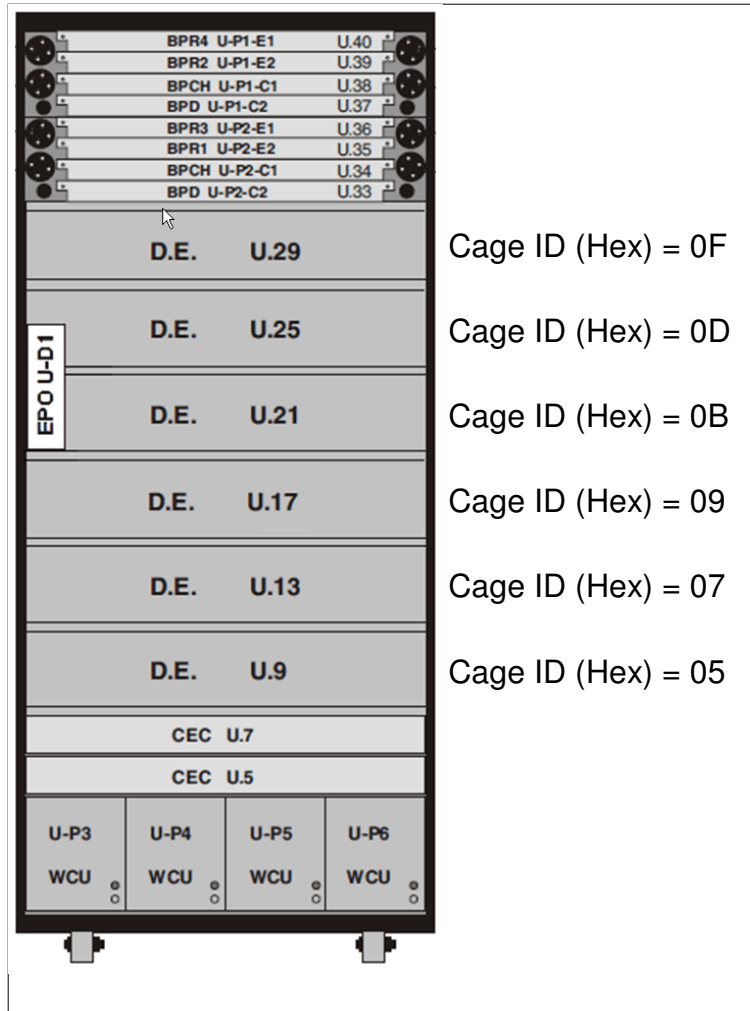

Figure 5 Disk Enclosure HEX Cage ID

Power775 Disk Enclosure Rail Service Procedure

- STEP 6 Locate the frame. Confirm that it is the correct frame by checking that its UEPO Panel Identify LED is blinking. This LED is located on the UEPO panel and it is marked by the “!” symbol (see Figure 6 and Figure 7).

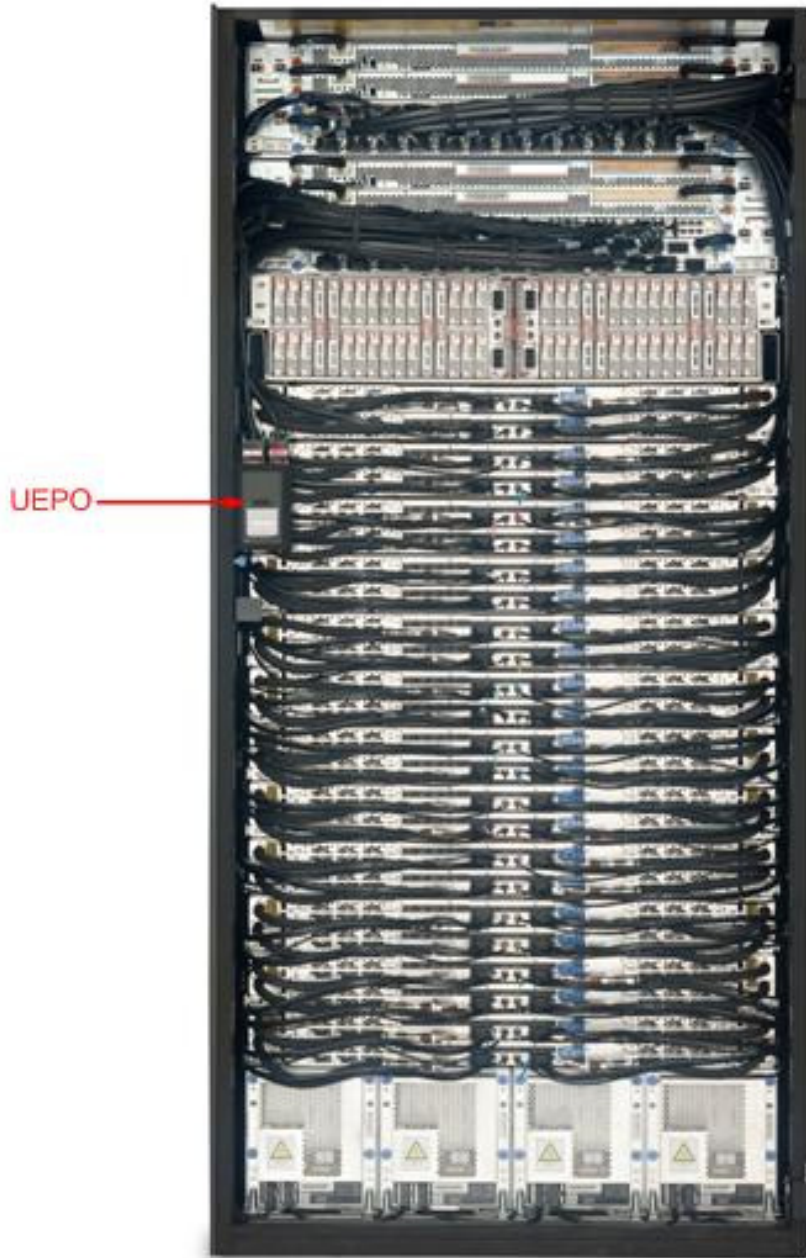

Figure 6 Frame Photo showing UEPO location

Power775 Disk Enclosure Rail Service Procedure

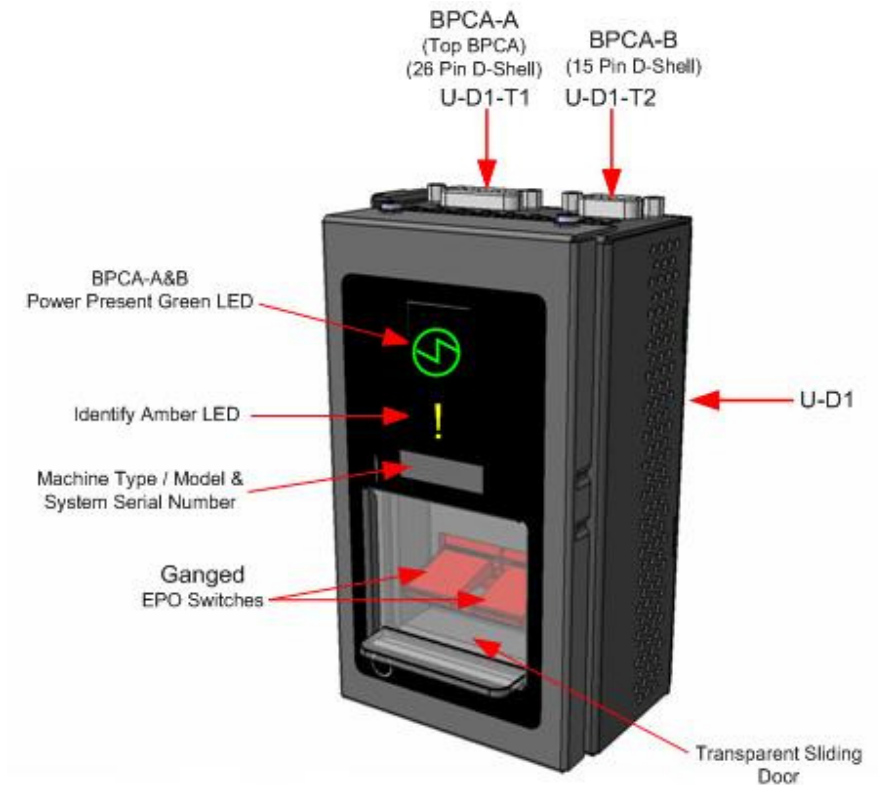

Figure 7 UEPO assembly showing frame Identify Amber LED

STEP 7 Open the front and rear doors



DANGER: Hazardous voltage present. Voltages present constitute a shock hazard, which can cause severe injury or death. (L004)

Locate the latch along the left side of the door; push in on the X button, the latch handle will pop out, extended out from the latch pocket. Grasp the latch handle and swing the door to the right (see Figure 8 and Figure 9).

Power775 Disk Enclosure Rail Service Procedure



Figure 8 Door Latch



Figure 9 Door Latch handle shown extended

Power775 Disk Enclosure Rail Service Procedure

STEP 8 If it will be needed for service, bring over the Ladder PN 46G5947 (shipped in the Power 775 Lift Tool Kit).

STEP 9 Identify the Disk Enclosure

Identify the Disk Enclosure with the failed fans by looking for the blinking amber Enclosure ID LEDs on the DE DCCAs on the front side of the Disk Enclosure (see Figure 10) OR on the right side of the rear of the Disk Enclosure (see Figure 11).

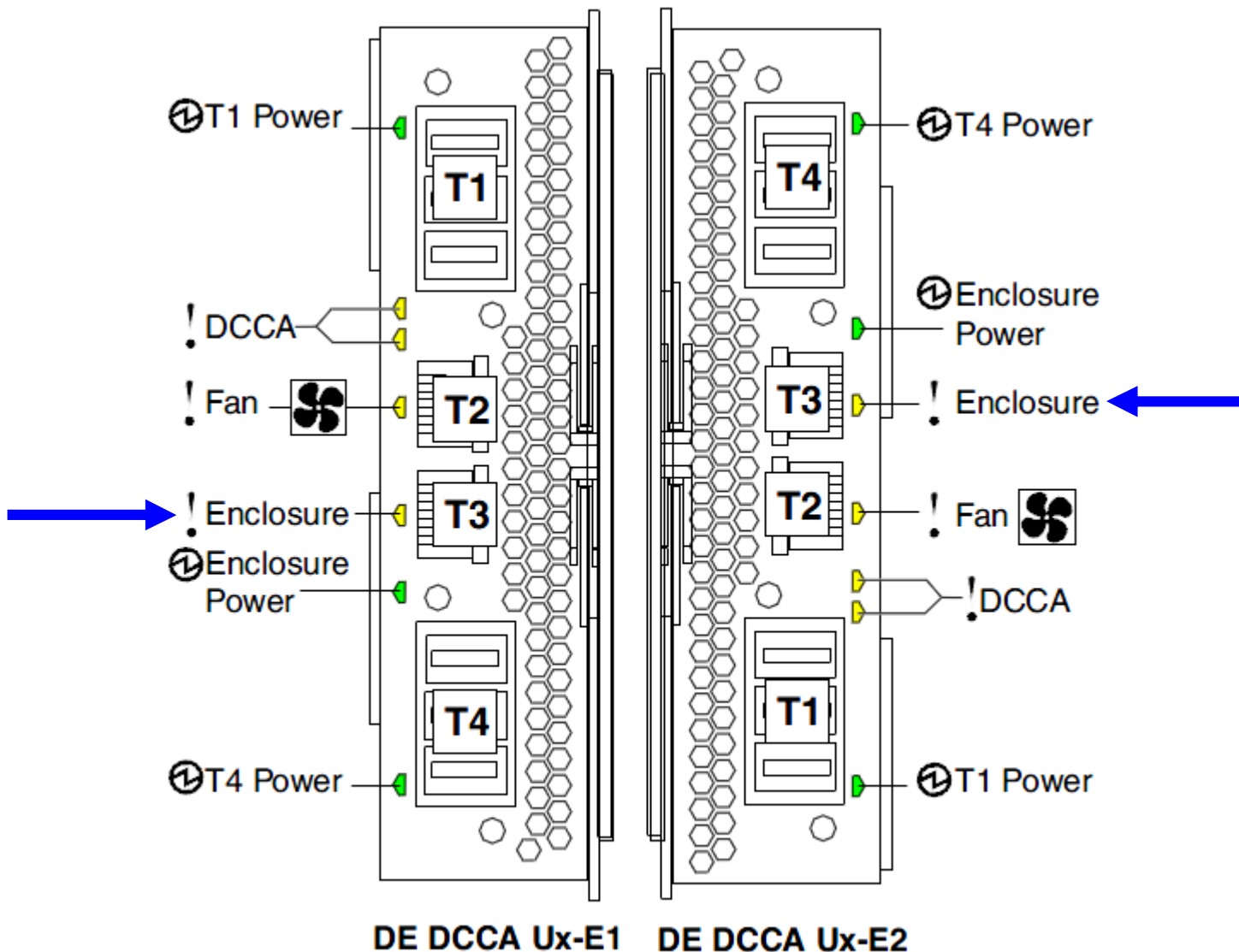

Figure 10 The Front Enclosure ID LED is located on the DE DCCAs

Power775 Disk Enclosure Rail Service Procedure

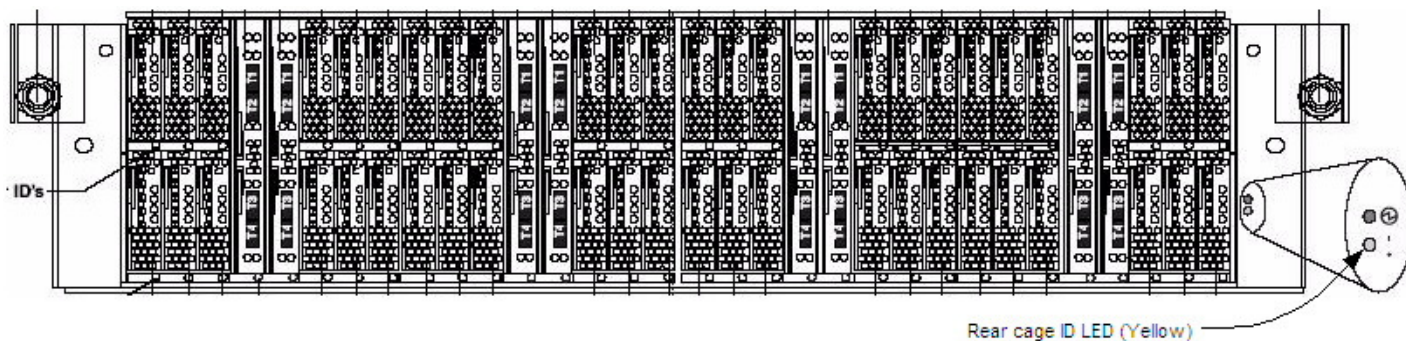

Figure 11 Rear Enclosure ID LED is located on the bottom right side of the DE

STEP 10 Check the Enclosure VPD Label

Verify that the location codes of the Fans to be replaced match the enclosure VPD Label of the DE you have identified (see Figure 5).

STEP 11 Turn off the Enclosure Identify LEDs of the DE by using the following command from the BPC FSP Command Line:

This is the command syntax:

```
bpccmd -c 27<blank>0000<cage ID><FRU ID><LED blink state 00=off, 02=blink>
```

<blank>	= "11"
<cage ID>	= see table below
<FRU ID>	= "01" for the DE Identify LED.
<LED state>	= "00" for this step

Type in the following, inserting the correct cage ID DE chassis location:

```
bpccmd -c 27110000xx0100
```

Where "xx" is the cage ID of the DE you are replacing.

This field will be 05,07,09,0B,0D, or 0F (see Figure 5).

The correct return code is 001100. If you do not receive this, contact the next level of support.

Below is an example assuming Cage ID=0f

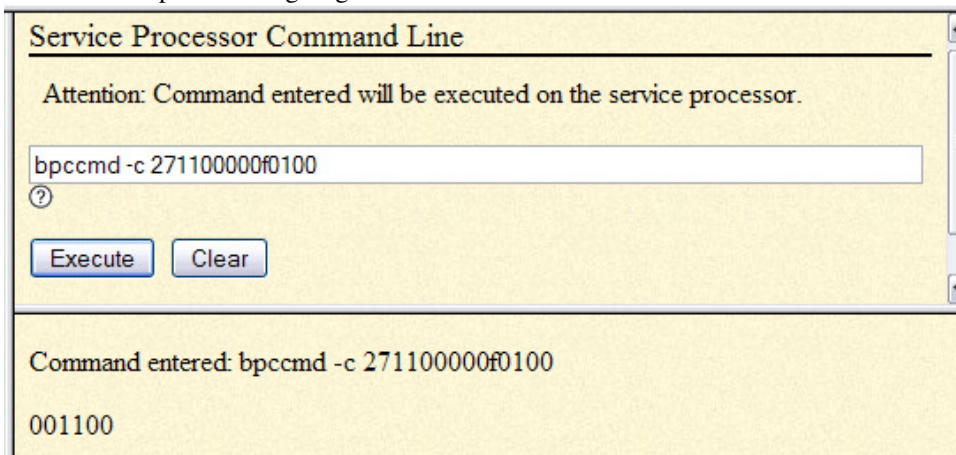

3.4 Power off the Disk Enclosure <= CUSTOMER TASK

STEP 12 Power Off the Disk Enclosure by using the following command from the BPC Command Line:

This is the command syntax:

```
bpccmd -c 40<blank>0000<cage ID>
```

<blank> = "11"
<cage ID> = see Figure 5

Type in the following, inserting the correct Cage ID for the DE you are servicing:

```
bpccmd -c 40110000xx
```

Where "xx" is the Cage ID of the DE you are servicing. This field will be 05,07,09,0B,0D, or 0F (see Figure 5).

The correct return code is 001100. If you do not receive this, contact the next level of support.

ATTENTION: Be very careful that you are in the correct frame and that you type this command exactly as it will power off the cage you type. If you are off by just one digit, you can easily power off a CEC or DE in another cage of the frame.

3.5 Confirm that 350V is off to the Disk Enclosure <= SSR TASK

STEP 13 Confirm that 350V is off

All LEDs in the DE should now be off. If they are not, **do not proceed**. Have the customer attempt the power off again or contact the next level of support.

It is possible for the DE to have its outputs off, but the 350V still on.

Check to make sure the green T1 and T4 350V Input Power LEDs have turned off on both DE DCCAs before proceeding (see Figure 12).

Power775 Disk Enclosure Rail Service Procedure

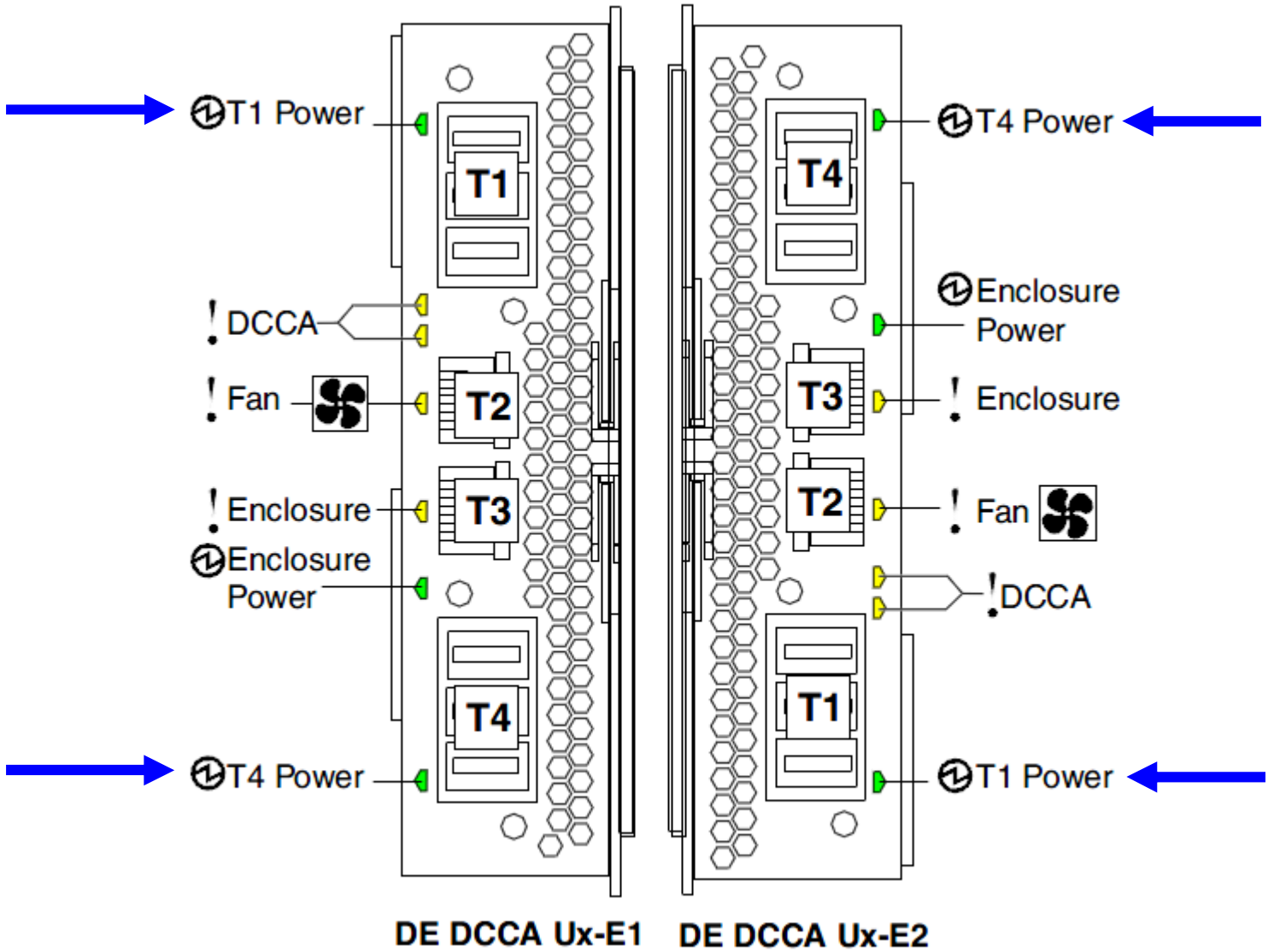

Figure 12: T1 and T4 Input Power LEDs on the DE DCCAs

3.6 Remove Front Door and Latch Plate, Move UEPO Panel <= SSR TASK

STEP 14 Remove the front door. The front door weighs 37lbs (16.8 kg).



CAUTION: Sharp edges, corners, or joints nearby. (L006)

- Face the inside of the door and place hands on the cross bars (see Figure 13 Removal of Front Door)
- Lift straight up off the hinge pins (see Figure 14 Door Hinge Pin)



Figure 13 Removal of Front Door

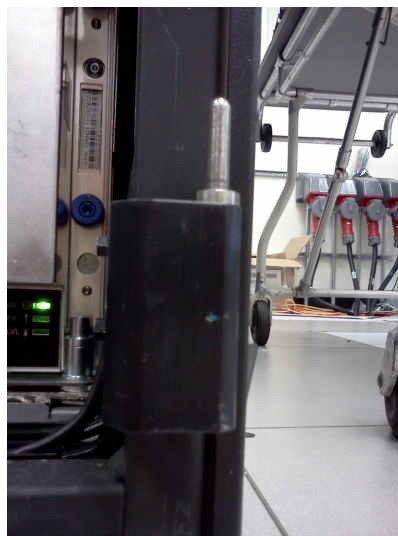

Figure 14 Door Hinge Pin

Power775 Disk Enclosure Rail Service Procedure

- STEP 15 Is the Disk Enclosure being serviced located in U21 or U25 (see Figure 15)?
- If “YES”, then go to STEP 16.
 - If “NO”, then go to STEP 20.

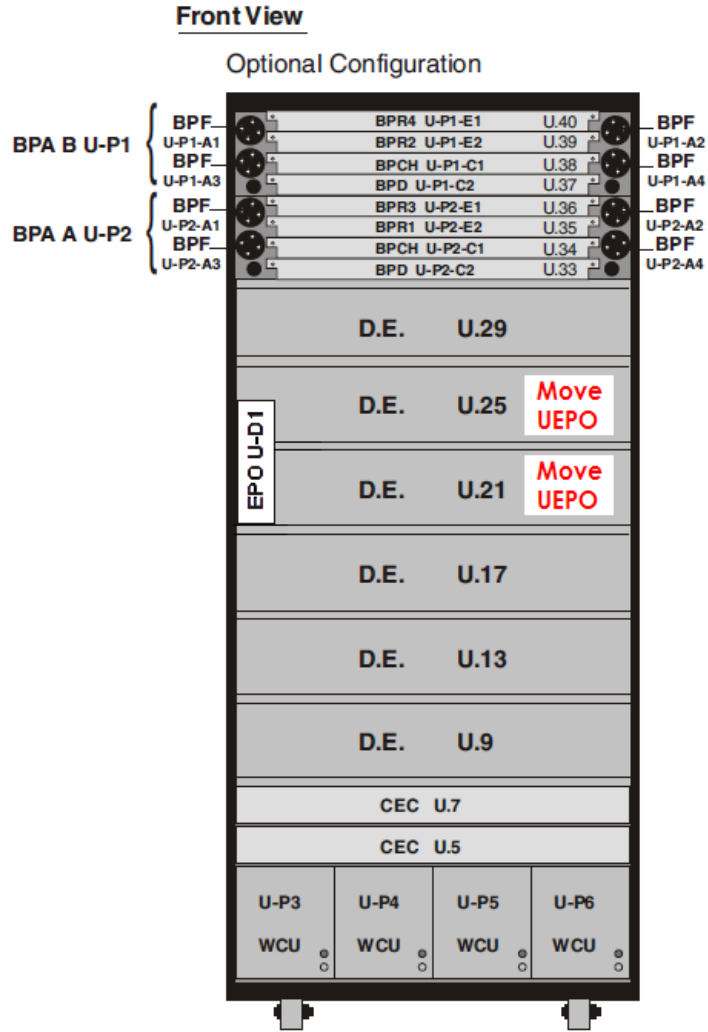

Figure 15: Disk Enclosure and UEPO Location Info.

STEP 16 **DO NOT** disconnect the UEPO cables and **DO NOT** put the UEPO switch in the “OFF” position. Loosen the blue-colored thumb screw located at the bottom of the UEPO using the Hex Driver torque tool PN 41V1059 (4mm Hex Driver 1.5-1.75 Nm) provided in the tool kit.

STEP 17 Unhook the UEPO switch assembly from the Rack by sliding it upward and then away from the Rack.

Power775 Disk Enclosure Rail Service Procedure

STEP 18 Place the UEPO in the “Frame UEPO Service Position” in the Rack (see Figure 16).

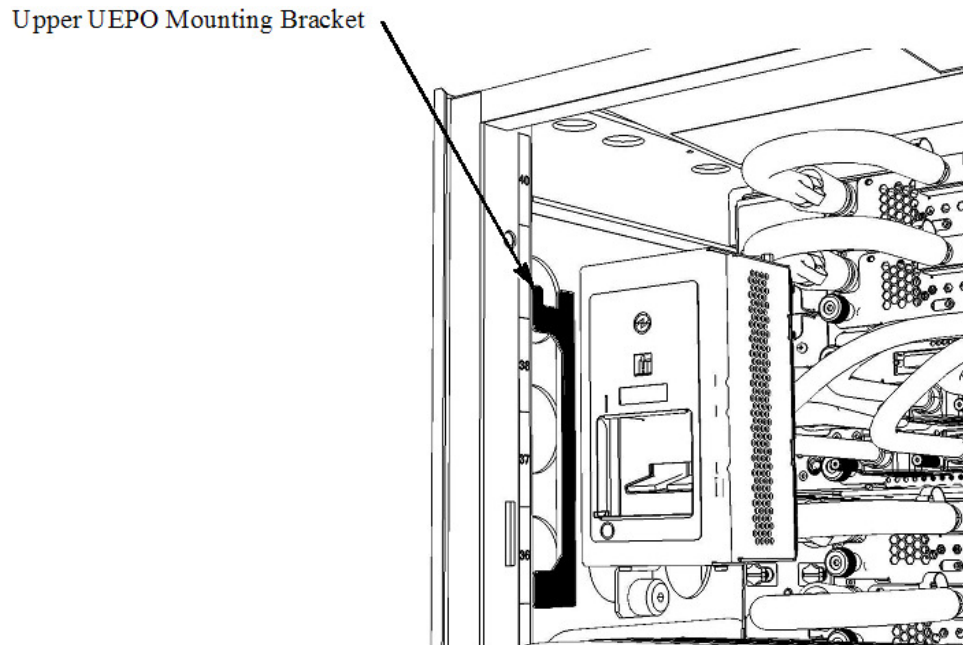

Figure 16: Frame UEPO Service Position

STEP 19 Hand tighten the UEPO blue thumb screw to secure the UEPO in the Rack.

STEP 20 Do the Disk Enclosure Rails being serviced reside in a DE located in U17 (see Figure 16)?

- If “YES”, then go to step 27.
- If “NO”, then go to step 29.

Power775 Disk Enclosure Rail Service Procedure

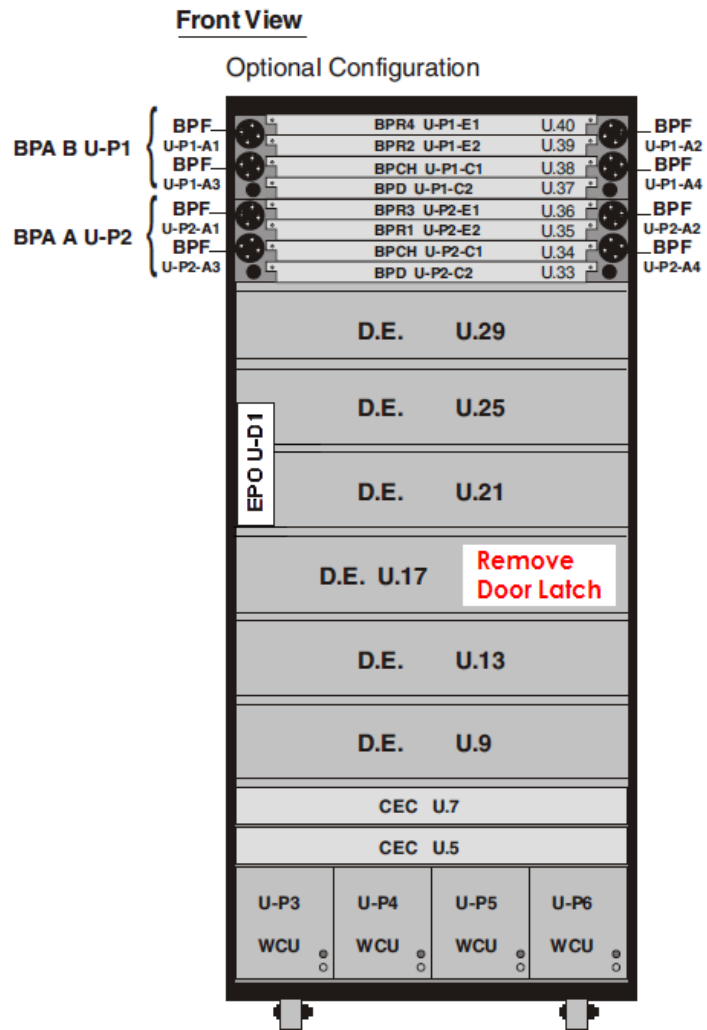

Figure 17: Disk Enclosure and Door Latch Plate Location Info.

STEP 21 Remove the door latch plate before proceeding. Unscrew the plate using the Hex Driver torque tool PN 41V1059 (4mm Hex Driver 1.5-1.75 Nm) provided in the tool kit using Figure 16 for reference.

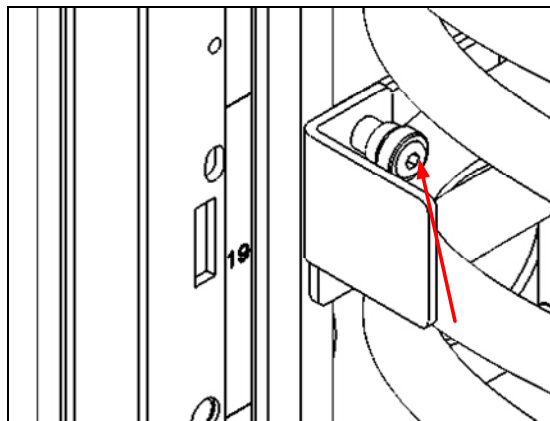

Figure 18: Door Latch Plate Screw Location

Power775 Disk Enclosure Rail Service Procedure

STEP 22 Remove latch plate from Rack per Figure 17.

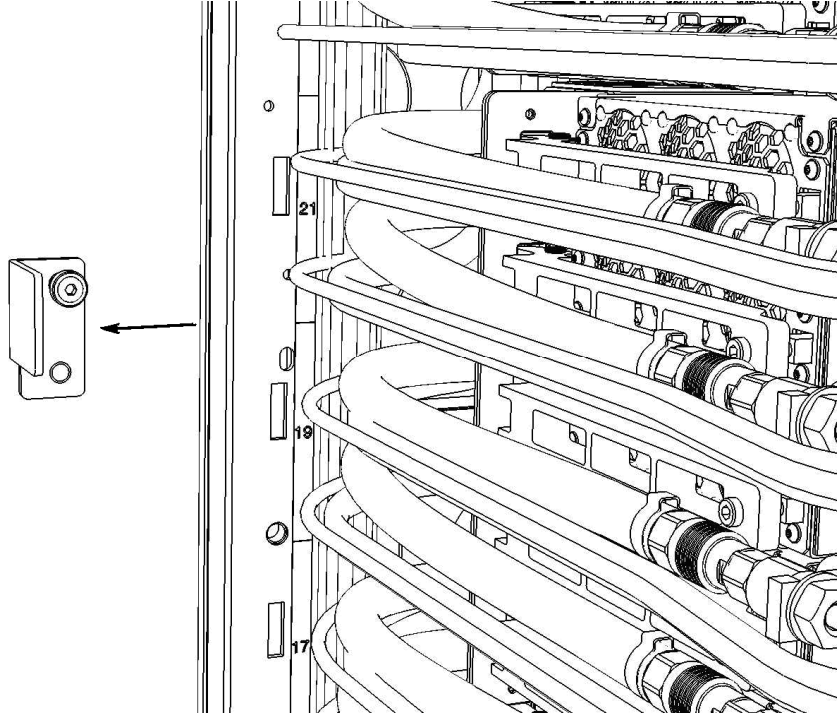

Figure 19: Door Latch Plate Removal

3.7 Disconnect Cables, Hoses, and Retention Screws <= SSR TASK

STEP 23 Disconnect the four DCCA Service Network Communications (E/NET) cables from both DE DCCAs by depressing the “retention clip” (see Figure 20 and Figure 21). **All cables should be labeled to help when re-cabling the DE.** If any of these cables are not labeled, label them now.

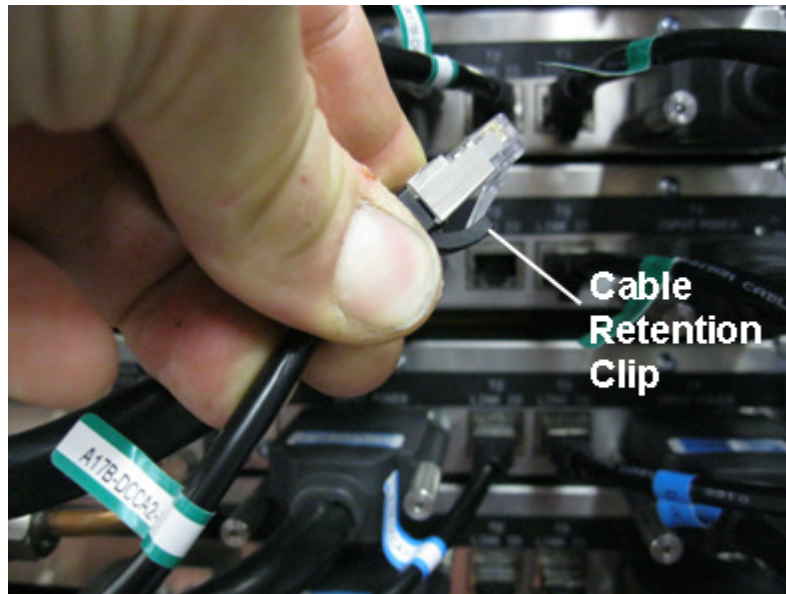

Figure 20: DCCA Service Network Communications (E/NET) Cable

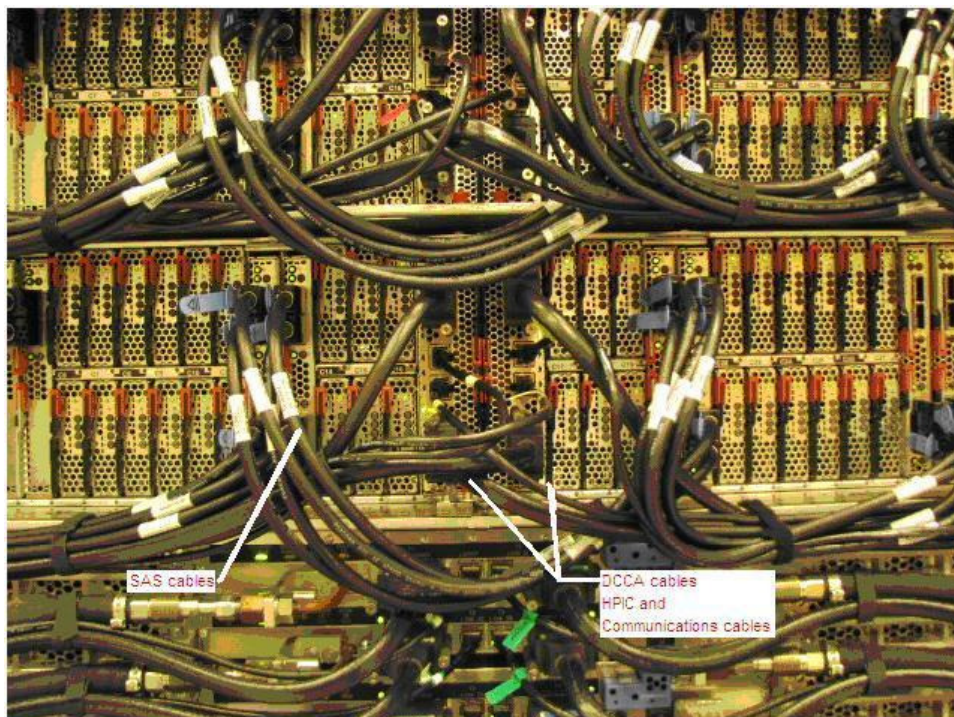

Figure 21 DE cabling

Power775 Disk Enclosure Rail Service Procedure

STEP 24 CAUTION: Following the service procedure assures power is removed from 350 VDC power distribution connectors before they are unplugged. However, unplugging 350 VDC power distribution connectors while powered on, should not be done because it can cause connector damage and could result in burn and/or shock injury from electrical arcing. (C039)

Using the 2mm Hex Torque Driver P/N 74Y0983, disconnect the four DCCA Power Cables (HPICs) from the DE DCCAs (see Figure 22). **All cables should be labeled to help when re-cabling the DE.** If any of these cables are not labeled, label them now.

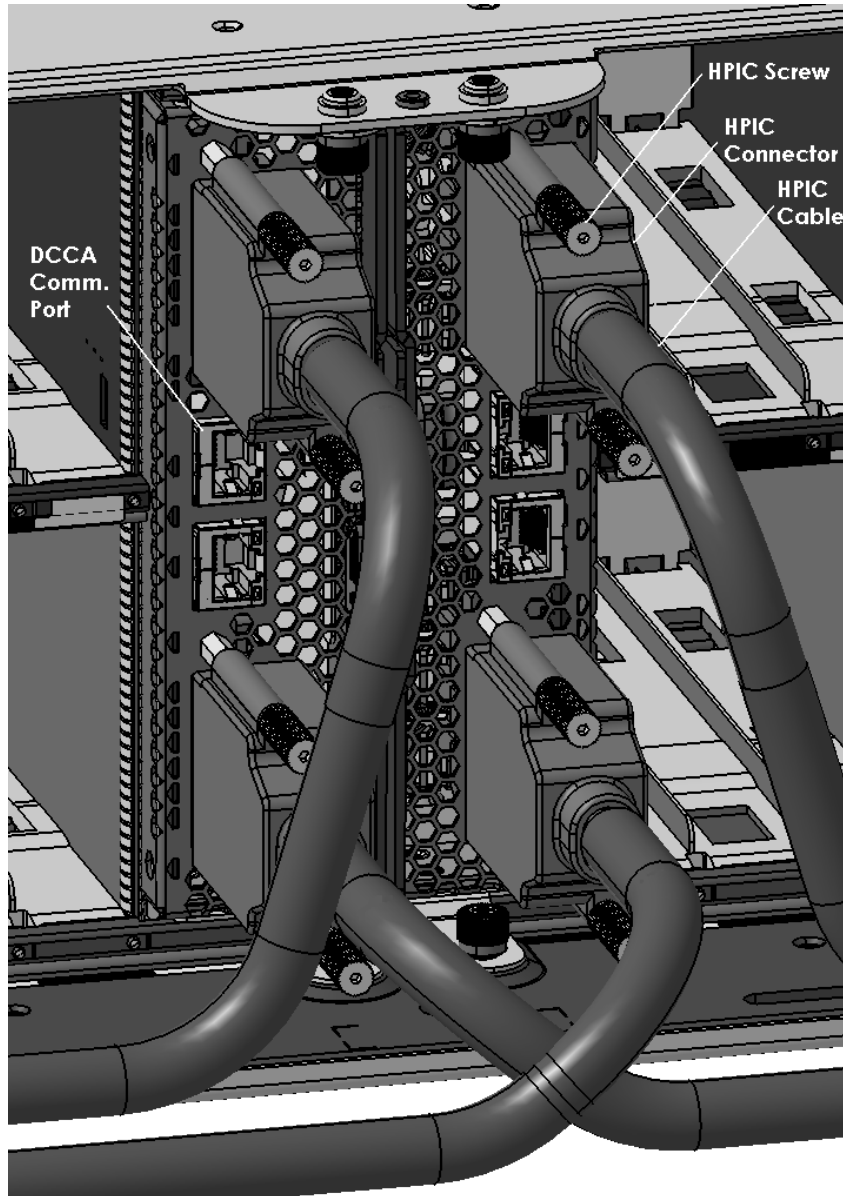

Figure 22: Disk Enclosure DCCA Power Cables (HPIC)

Power775 Disk Enclosure Rail Service Procedure

STEP 25 Identify the SAS cables that need to be disconnected and disconnect them.

The SAS cables connect to Port Card in the front and rear of the DE. All cables should be labeled to help when re-cabling the DE. Find the SAS cables that connect the DE to CECs. **If any of these cables are not labeled, label them now.** Disconnect these cables from the DE. There will be up to 32 such cables (see Figure 23). You may have to remove some of the velcro ties in order to disconnect the cables.

There may also be SAS cables that connect Port Cards in the DE to other Port Cards in the same DE; e.g. if the DE is cascaded. Do not disconnect these cables. Make sure they are dressed sufficiently that they do not get stuck on anything when you slide out the DE in a later step.

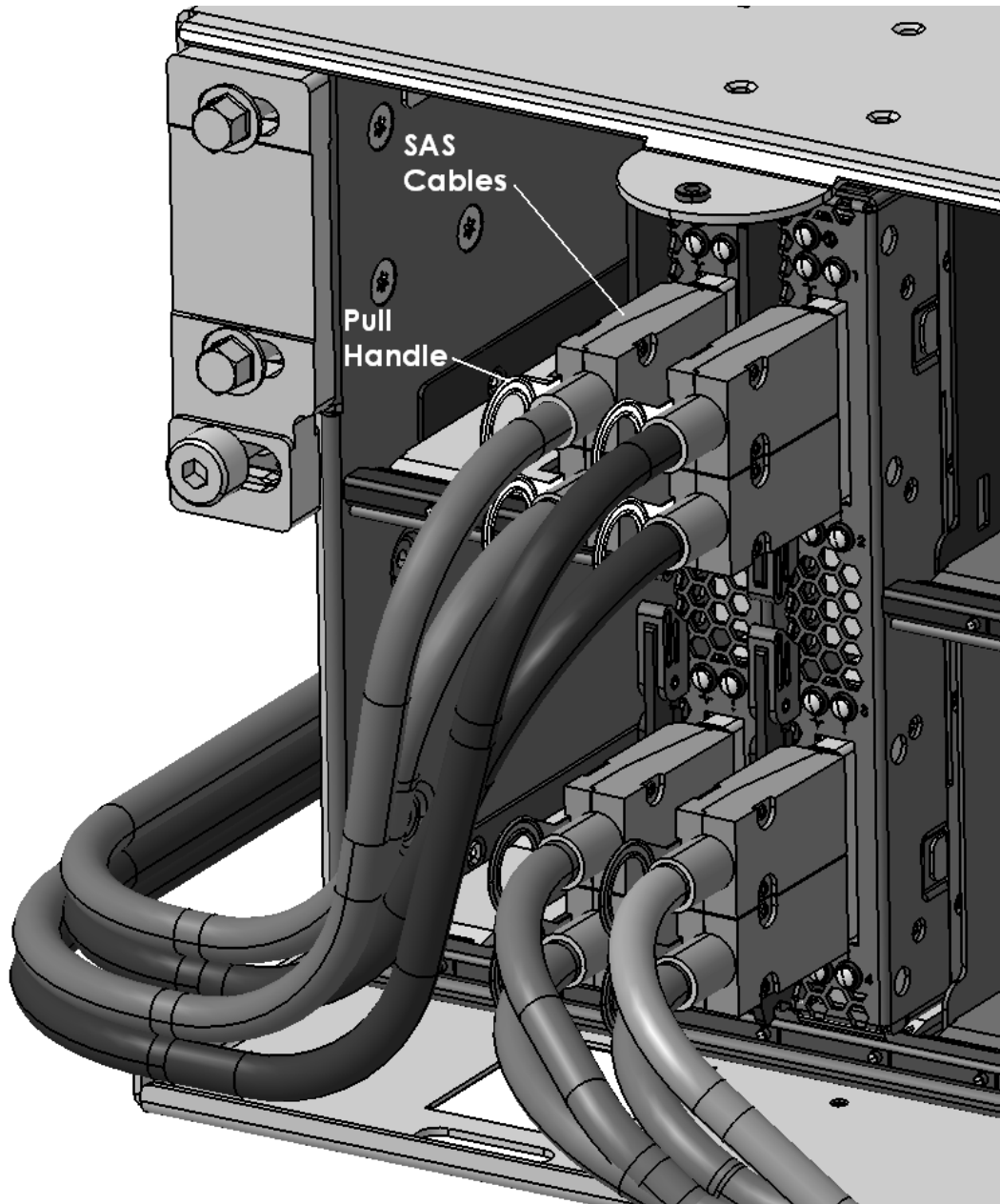

Figure 23: Disk Enclosure Port Card Cabling

Power775 Disk Enclosure Rail Service Procedure

STEP 26 Locate the two Front Rail Block Captive Allen head screws (one on the left side and one on the right side of the DE) which hold the Front Rail Block to the DE Rails (see Figure 25).

Loosen these screws using the 5mm Hex Torque Tool PN 74Y0986 (shipped in the Hand Tool Kit). Rotate the 4 screws counterclockwise until they are free from the DE.

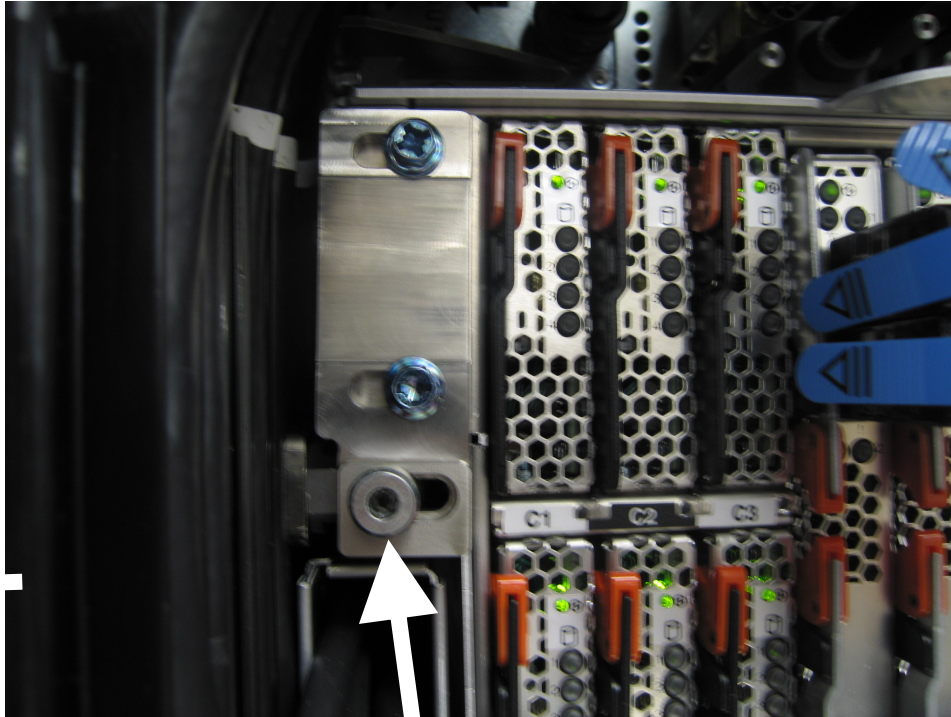

Figure 24 Photo of Front Rail Block Captive Screw

STEP 27 Determine if the Front Rail Blocks will interfere with any cables (which will damage the cables). If you are sure they will not interfere, you can leave them attached.

If they will interfere with any cables, remove the Front Rail Blocks by loosening the four Front Rail Block Hex Screws (two on the left side, and two on the right side of the DE) (see Figure 25) using the following tools:

- Ratchet handle P/N 6428240 (shipped in the Hand Tool Kit)
- Extension (18") P/N 46K2707 (shipped in the Hand Tool Kit)
- 10 mm Socket P/N 02F3582 (shipped in the Hand Tool Kit)

If you have removed the Front Rail Blocks, store the blocks and hex screws for reinstalling later.

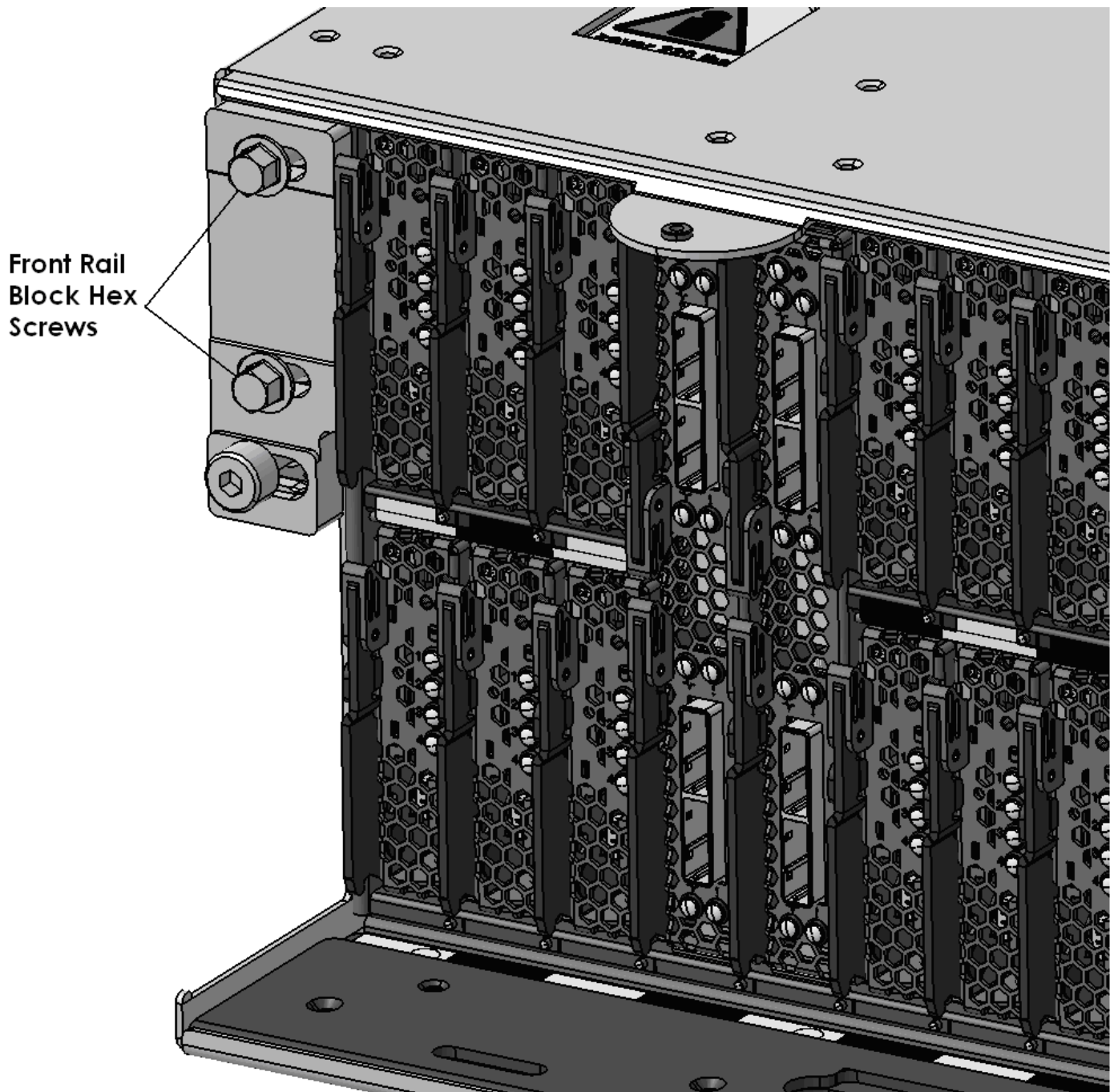

Figure 25: Front Rail Block Screws

Power775 Disk Enclosure Rail Service Procedure

STEP 28 Disconnect the 2 Water Hoses from the rear of the Disk Enclosure by pulling the retaining ring on the hose (see Figure 26 Water Hose Connector).

CAUTION: The water-based coolant solution may contain an additive intended to inhibit corrosion (or provide other functions). The solution may cause irritation to the skin or eyes. Avoid direct contact with the solution. Employ appropriate Personal Protective Equipment when performing operations involving the coolant or which may potentially expose you to the coolant. Refer to the MSDS for more information. (C037)



CAUTION: Protective eyewear is needed for the procedure. (L011)



CAUTION: Chemical resistant gloves are needed for this procedure. (L014)

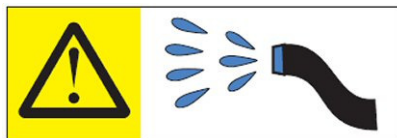

DANGER: Risk of electric shock due to water or a water solution which is present in this product. Avoid working on or near energized equipment with wet hands or when spilled water is present. (L016)

ATTENTION: Observe the 4 safety notices above for all future steps involving attaching or disconnecting water hoses.

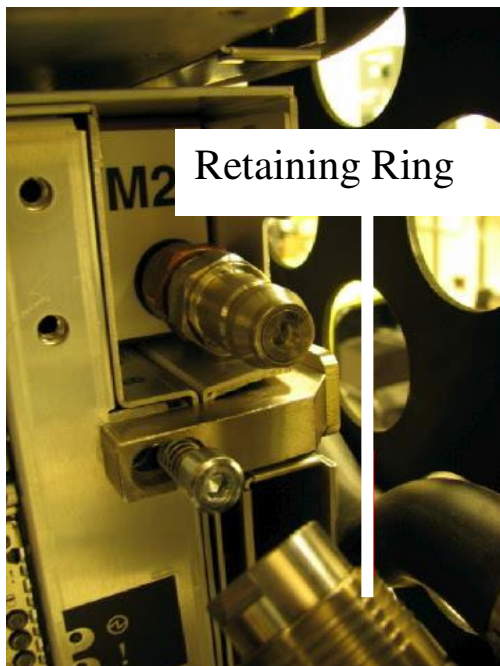

Figure 26 Water Hose Connector

Power775 Disk Enclosure Rail Service Procedure

- STEP 29 Locate the two Rear Rail Block Captive Allen head screws (one on the left side and one on the right side of the DE) which hold the Rear Rail Block to the Rack Slide-Rails (see Figure 27).

Loosen these screws using the 5mm Hex Torque Tool PN 74Y0986 (shipped in the Hand Tool Kit). Rotate the 4 screws counterclockwise until they are free from the DE.

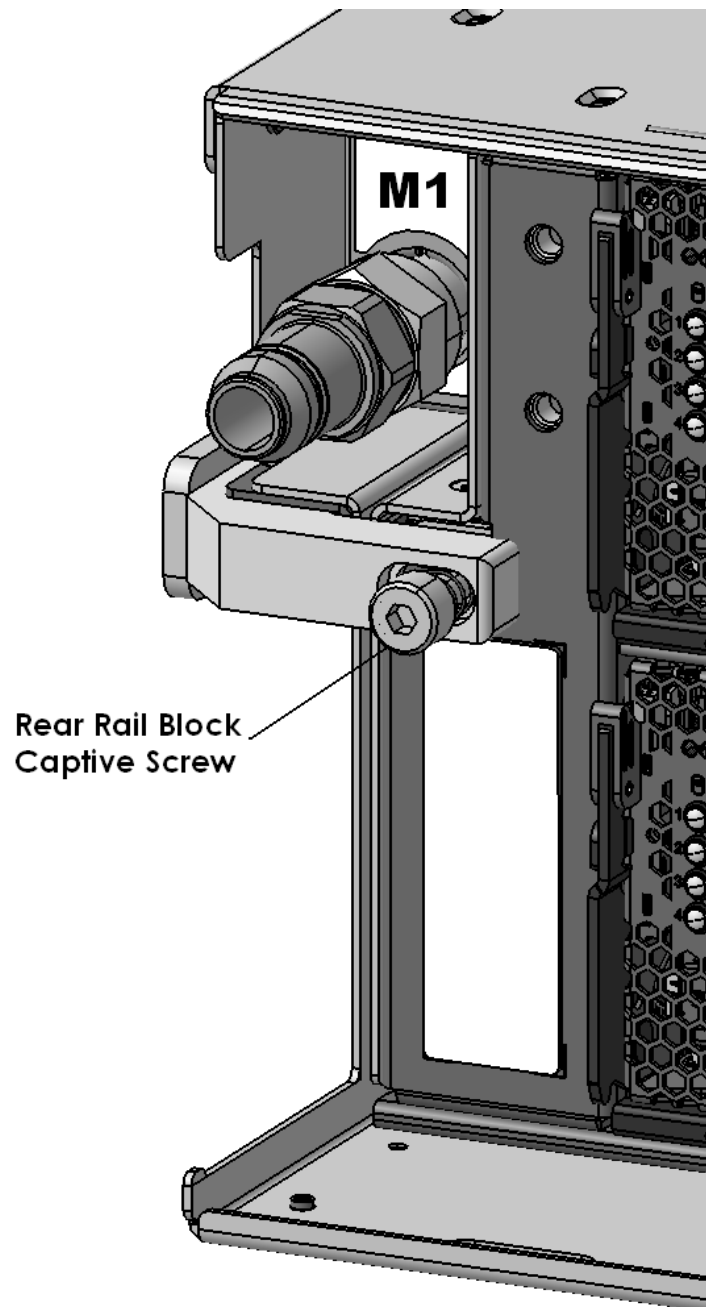

Figure 27: Disk Enclosure Rear Rail Block Captive Screws

3.8 Attach the Lift Tool to the frame <= SSR TASK

- STEP 30 Find the frame attachment bracket on the lift tool (see Figure 28).
Find the lift tool anchor locations on the front side of the Power 775 frame (see Figure 29).
Slide the Lift Tool up against the frame (see Figure 30).

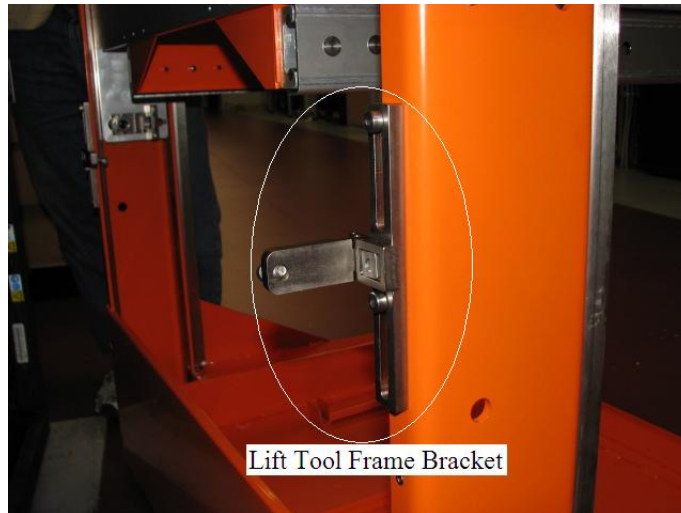

Figure 28 Lift Tool attachment Bracket

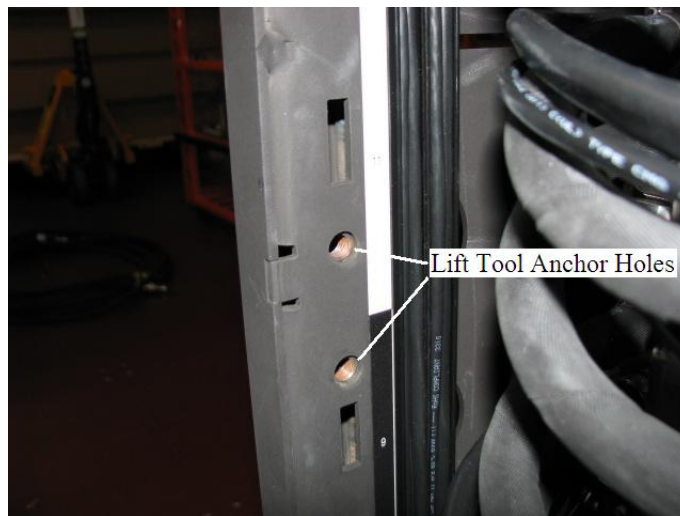

Figure 29 Lift Tool Anchor Holes

Power775 Disk Enclosure Rail Service Procedure

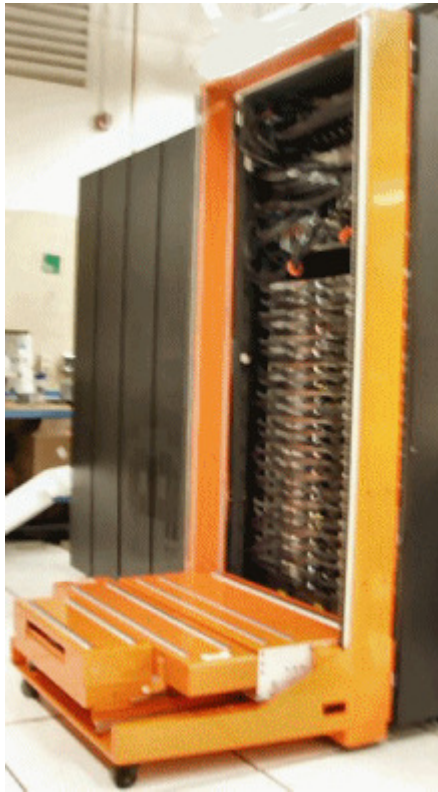

Figure 30: Lift Tool against Front Side of Frame

- STEP 31 Using the 5 mm Hex tool P/N 74Y0986 and 3/8in-ratchet handle 23-31 Nm torque clutch P/N 74Y0985 (shipped in the Hand Tool Kit), screw the attachment screws into the Lift Tool anchor holes in the frame and torque screws until seated (see Figure 31).



Figure 31 Lift Tool attached to frame

Power775 Disk Enclosure Rail Service Procedure

STEP 32 Extend and flip up the lift tool Front Table Stop (see Figure 32).

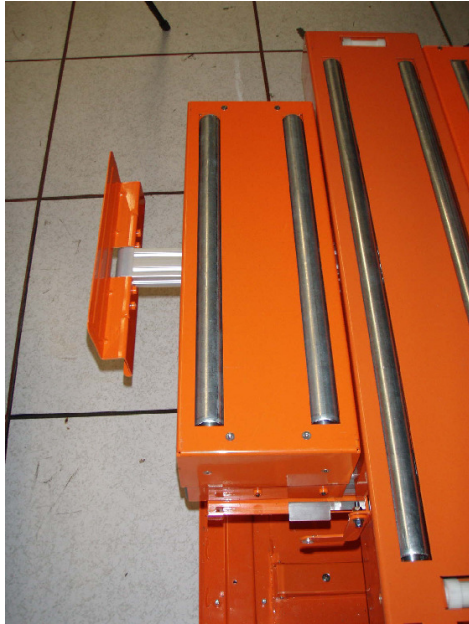

Figure 32: Front Table Stop

STEP 33 Ensure that all the cables of the rack are dressed such that the lift table will not catch on cables as it is moved up and down across the face of the rack (see Figure 33 and Figure 34).

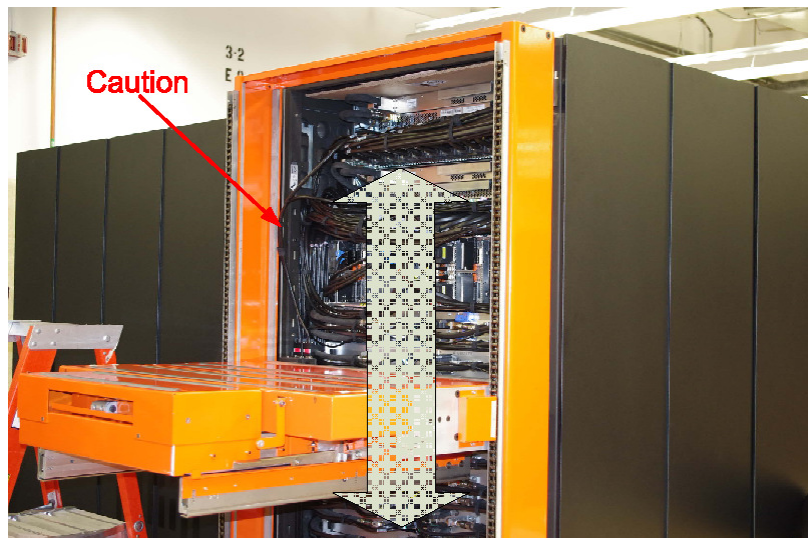

Figure 33: Lift Table Movement Path

Power775 Disk Enclosure Rail Service Procedure



Figure 34: Secure Cables

- STEP 34 Ensure that the UEPO will not be hit as the table moves up and down. Also ensure that the UEPO is secured to the frame so it does not move during the service procedure.
- STEP 35 Raise the lift tool table just below the DE to be removed. The platform is raised via the Table Lift Drive, using the battery powered drill shipped with the Lift Tool.

ATTENTION:

- Use two hands to operate the battery powered drill as it is a high torque tool (see Figure 35).
- Use the “Drill” setting on speed “LOW (1)” (Figure 36).
- Be aware that when lowering the tool, as you approach the bottom of the lift table range, reduce the speed of the drill to avoid high torque to the hands and drill slippage from the tool.

Required Tools:

Milwaukee Cordless Drill 2602-20 & Milwaukee 18V Lithium-ION Battery 48-11-1828

Power Drill Operation – Correct Technique

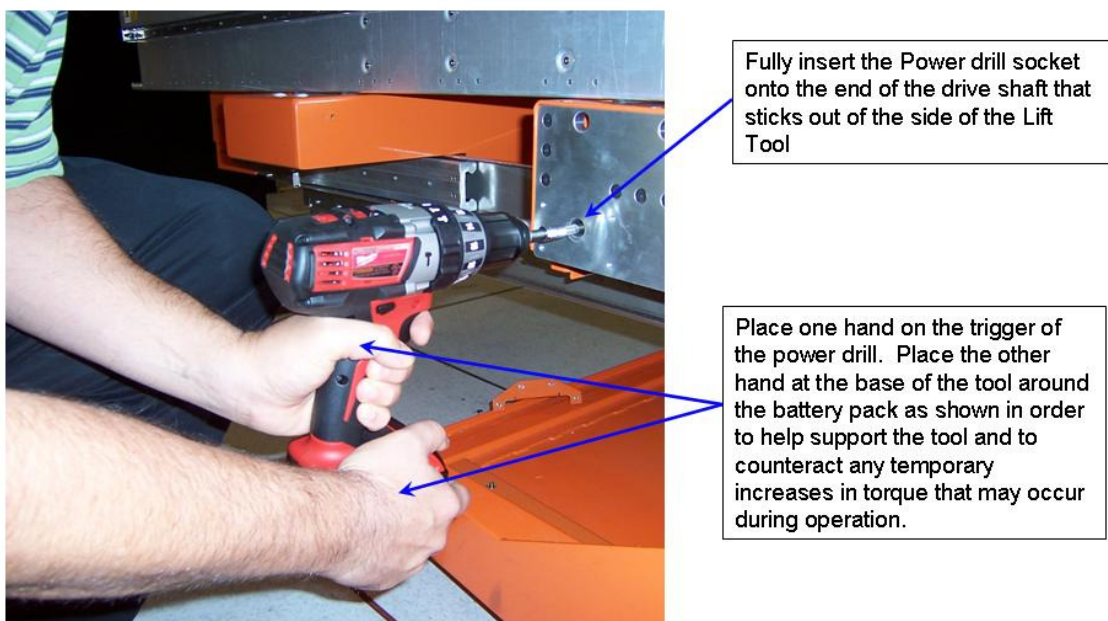

Figure 35 Power Drill Operation – Correct Technique

Power Drill Operation – Correct Settings For Use

Set the operating mode to the **DRILL** setting, as depicted in the image shown

NOTE: Tool cannot generate enough torque to use with the Lift Tool when set to the **SCREW** operating mode

NOTE: Tool *can* be used in the **HAMMER** mode, but this is *not recommended* since it makes the tool a bit more difficult to handle

Set the speed switch for use at the **LOW (1)** speed setting

NOTE: The drill may not be capable of developing enough torque to lift / lower heavy payloads if the speed switch is set for use at the **HIGH (2)** spread setting

NOTE: The **ADJUSTABLE TORQUE** settings only work in **SCREW** mode, which is not supported for use with the Lift Tool

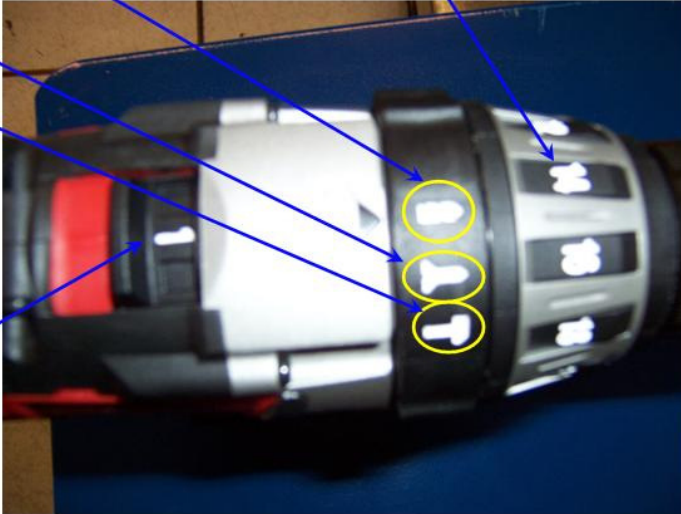

The image shows a close-up of a power drill's handle. Three yellow circles are drawn around the mode selector (top), the speed switch (middle), and the adjustable torque ring (bottom). Blue arrows point from the text boxes to these specific controls. The mode selector is currently set to the 'DRILL' position. The speed switch is set to the 'LOW (1)' position. The adjustable torque ring is also visible, with an arrow pointing to it from the top-right note.

Figure 36 Power Drill Operation – Correct Settings for Use

STEP 36 If necessary bring over Ladder P/N 46G5947 shipped with the POWER 775 Lift Tool Kit.

3.9 Move the Disk Enclosure onto the Lift Tool <= SSR TASK

CAUTION: Do not remove or install this unit without using the provided lift tool. (C017)



DANGER: Hazardous voltage present. Voltages present constitute a shock hazard, which can cause severe injury or death. (L004)



CAUTION: Sharp edges, corners, or joints nearby. (L006)



CAUTION: System or part is heavy. The label is accompanied by a specific weight range. (L009)
ATTENTION: The DE weighs about 550 lbs (250 kg) when full.



CAUTION: Pinch hazard. (L012)
ATTENTION: Small gaps exist that could pinch body parts if care is not exercised.



DANGER: Heavy equipment—personal injury or equipment damage might result if mishandled. (L013)

STEP 37 Ensure the DE will clear all cables.

Lift the DCCA cables that were connected to the DE out of the left raceway to create clearance for the DE to slide out of the frame (see Figure 37). Make sure the DE, especially the corners, will clear all cables.

For some DE locations it may be necessary to use the cable protector sheet P/N 41U8226 shipped with the hand tool kit 74Y0988 (see Figure 38). Fold the cable protector sheet (see Figure 39) and slide the folded sheet between the DE chassis and any interfering cables (see Figure 40).

Power775 Disk Enclosure Rail Service Procedure



Figure 37 Relocate the DCCA cables

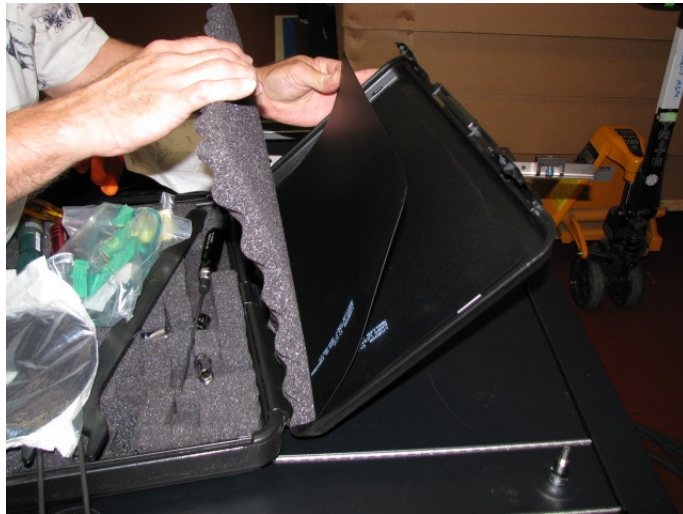

Figure 38 Cable Protector Sheet



Figure 39 Fold Cable Protector Sheet

Power775 Disk Enclosure Rail Service Procedure



Figure 40 Cable protector sheet shown in upper left position

STEP 38 Grasping the blue-purple recessed touch points on the front DE cable tray, pull the DE out of the frame a few inches until the front cable tray is just above the first Lift Tool roller (see Figure 41).

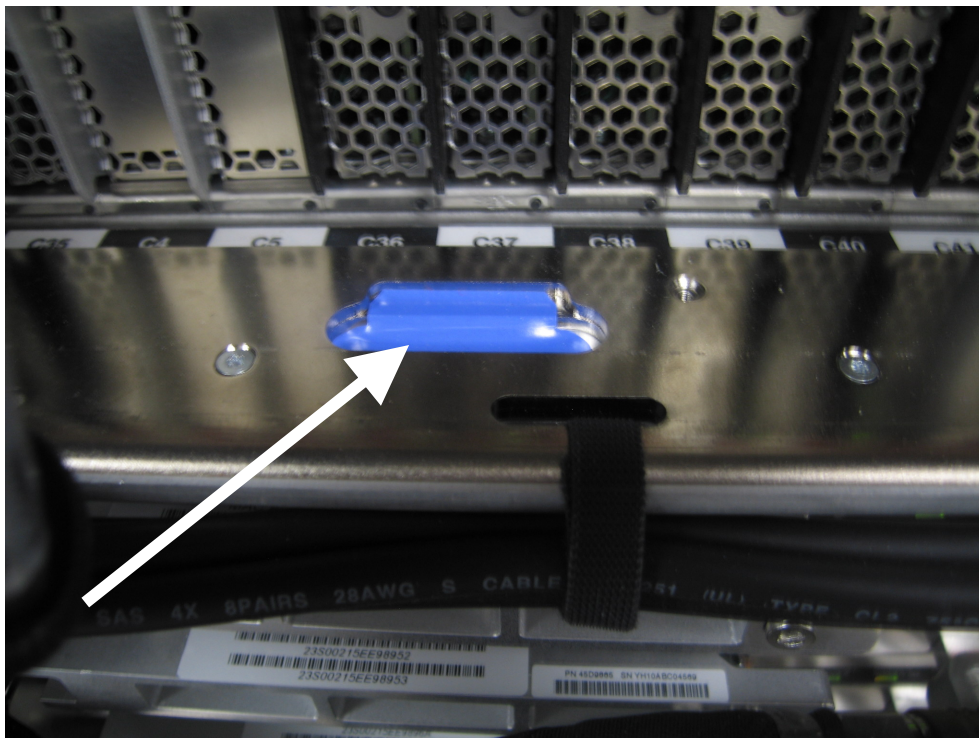

Figure 41 Blue-purple Recessed Touch Points

STEP 39 Raise the Lift Tool until the roller contacts the DE.

- Using the *Manual Drive* raise the lift tool table so it contacts the DE and then slightly further to transfer the DE weight to the lift tool table. *Do not raise the lift tool table too high as this will result in the DE being driven into the CEC or BPA above which can cause damage* (see Figure 42).

Power775 Disk Enclosure Rail Service Procedure

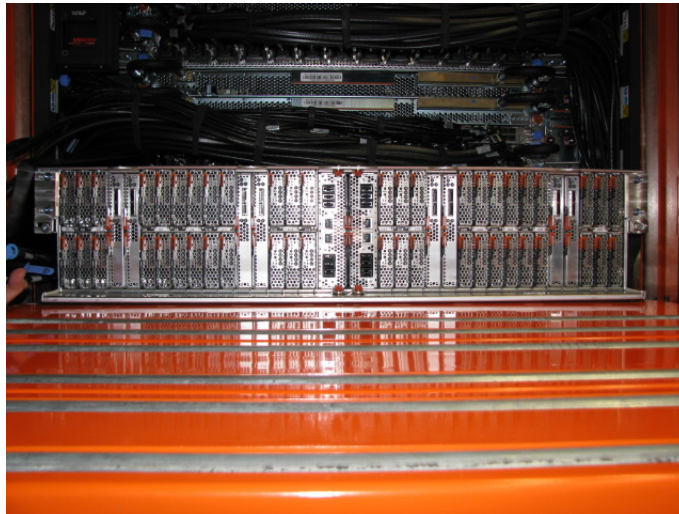

Figure 42 Front of DE resting on lift tool

- STEP 40 Grasping the recessed touch points on the DE cable tray, slide the DE forward onto the Lift Tool **slowly** so that the Safety Latches do not get damaged when they engage on the rack rails (see Figure 43).
- The DE should slide about half way out and then the right side safety latch will engage on the Rack rail to stop the DE from sliding out any further.



Figure 43 DE slid out slowly to point of latch engagement

ATTENTION: Do not go under the DE while it is partially or fully out of the frame

- STEP 41 Using the 4mm Hex driver P/N 41V1059 (shipped in Hand Tool Kit P/N 74Y0988), release the DE safety latches (see Figure 44 and Figure 45).
- a. Hold the right latch up with the tool while pulling the drawer forward until the left latch is engaged.
 - b. Release the right latch
 - c. Lift the left latch up with the tool, slide the DE forward, and then release the left latch.

Power775 Disk Enclosure Rail Service Procedure

NOTE: When releasing latches it may be necessary to slide the DE back toward the frame slightly ($< 1\text{mm}$) to release the tension on the latch.

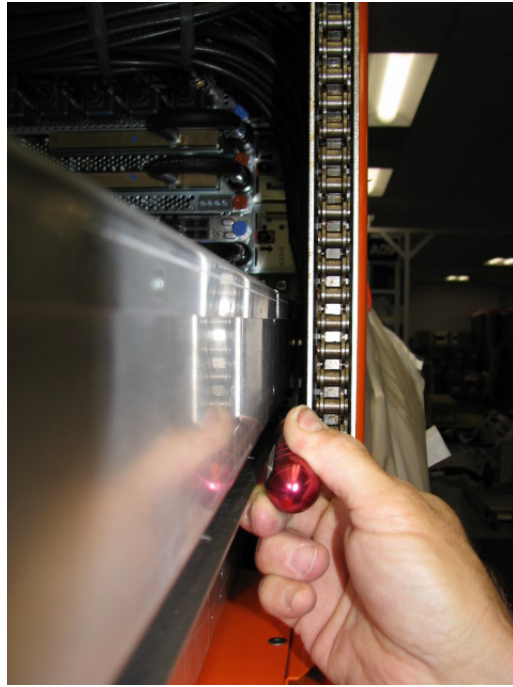

Figure 44 Disengage the right latch first

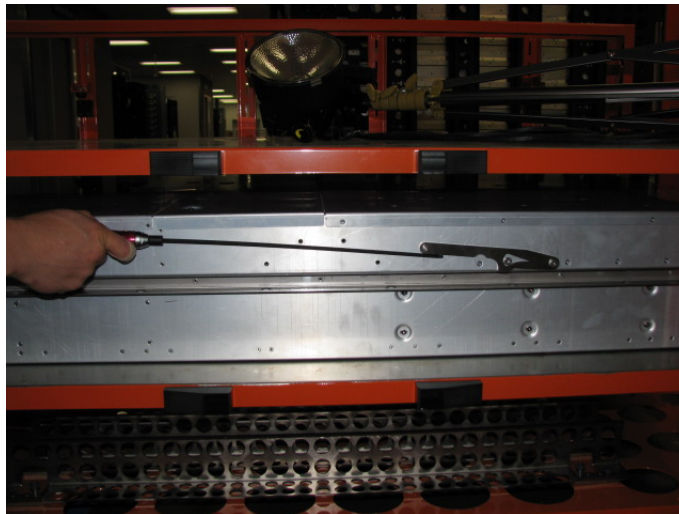

Figure 45 Side view of latching system of DE out of frame

Power775 Disk Enclosure Rail Service Procedure

- STEP 42 Slide the DE out of frame until it is completely supported by the lift tool and will not interfere with the frame when the Lift Tool is raised or lowered (see Figure 46 and Figure 47).



Figure 46 DE removed from frame



Figure 47 DE supported by Lift Tool and cage stop bracket

- STEP 43 Using Battery powered drill shipped with the Lift Tool, 5/16 inch socket , ¼ inch drive adapter P/N 39F8449 lower the Lift Tool Table so that the DE is out of the way and you have access to the DE Rails.

ATTENTION: Do not go under or reach under the DE while it is on the Lift Tool.

3.10 Remove defective DE Rails <= SSR Task

- STEP 44 Carefully remove any SAS cables by pulling them through the defective Rail cable channels and towards the back of the frame.
- STEP 45 Perform STEPS 44,45 and 46 on both the right and left DE rails. Using 3/8in-ratchet handle 23-31 Nm torque clutch P/N 74Y0985, 30cm (12in) socket extension, 5mm hex socket bit (PN 74Y0986), loosen the four rail mounting captive screws (see “A” in Figure 48 and see Figure 49).



Figure 48: Disk Enclosure Drawer Rail Mounting Screws

- STEP 46 Slide the rail assembly gently towards the front of the Rack to disengage the “mushroom” pins (see “B” in Figure 49).

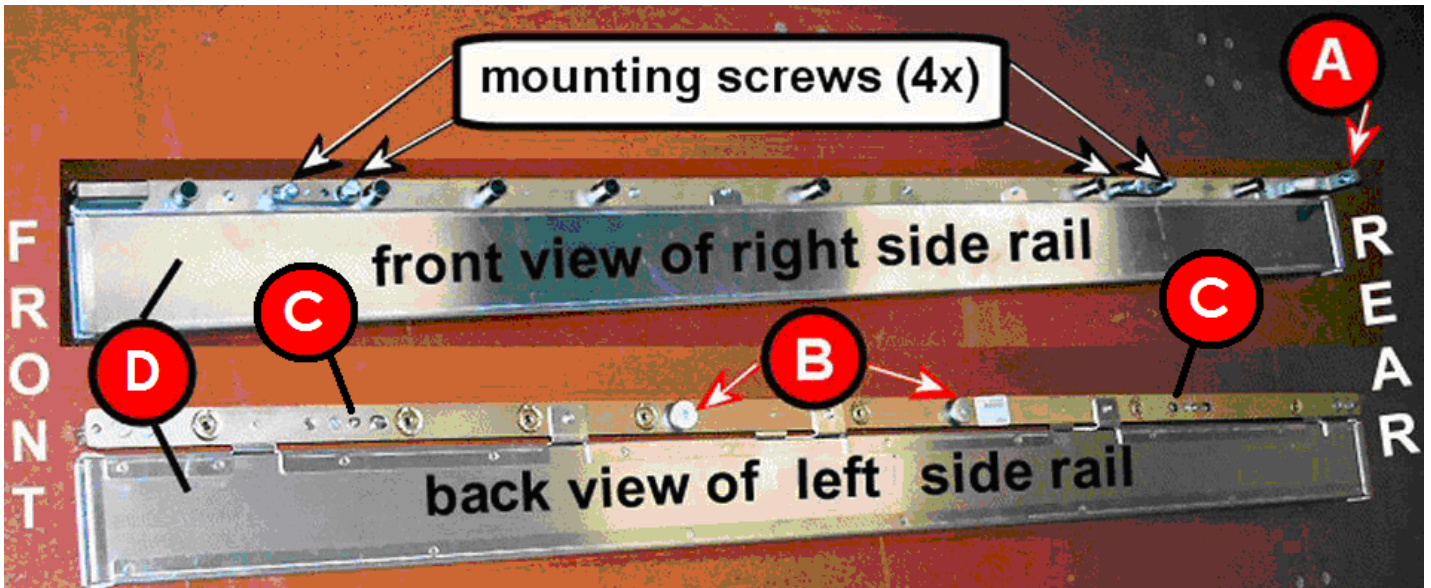

Figure 49: Disk Enclosure Drawer Rails

- STEP 47 Remove DE Rail assembly from the frame.

3.11 Install new DE Rails <= SSR Task

STEP 48 Review that the Rails are properly oriented for Rack installation (Figure 50).

- The rail end with the thumbscrew (A) is installed at rear of the Rack.
- The two “mushroom” pins (B) and two guide pins (C) face in toward the Rack key holes.
- The side conduits (D) will be used for routing SAS cables.

STEP 49 Facing the front of the Rack, position the left side rail “mushroom” pins with the appropriate slots (B) and guide pins with the appropriate key slots (C) on the Rack (see Figure 50 and Figure 51).

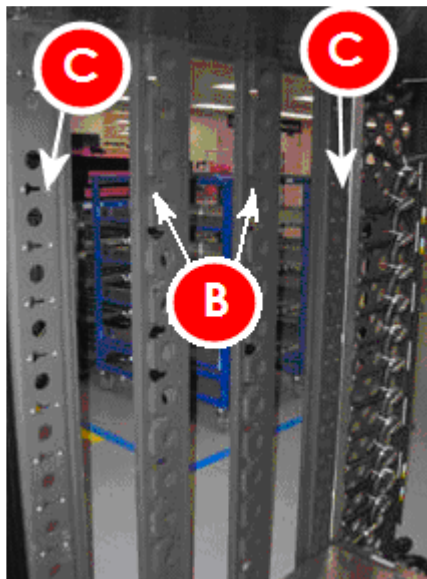

Figure 50: Rack Key Slot Locations

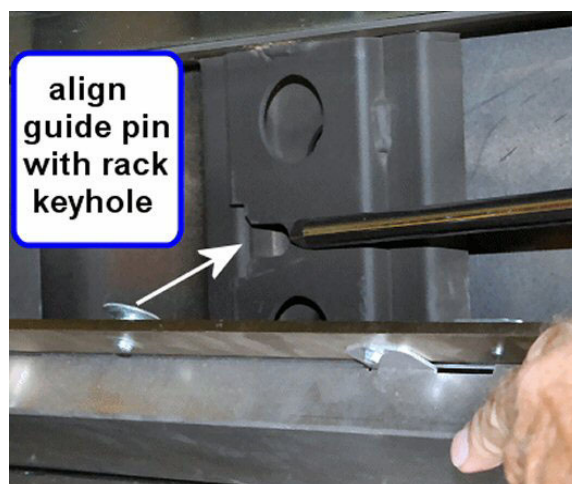

Figure 51: Align Mushroom Pins in Rack

Power775 Disk Enclosure Rail Service Procedure

- STEP 50 Align and insert the two guide pins on the back of the rail into the key holes in the frame.
- STEP 51 As you position the rail, you will need to slide it towards the rear of the frame in order to engage the “mushroom” pins into their appropriate slots.
- Note the rail guide pins will sit in the Rack key hole (see Figure 52).

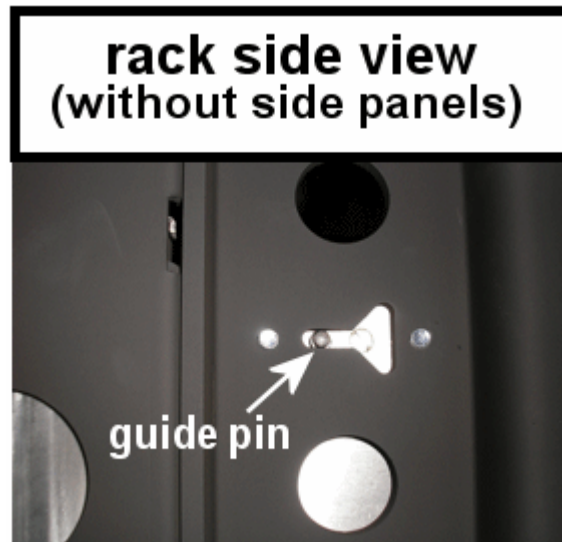

Figure 52: Rack Outer Side View of Installed Rail

- STEP 52 Locate the four Rail mounting captive screws
- First, start to fasten the captive screws by hand to prevent cross-threading of the screw and threaded hole.
 - Second, tighten the rail mounting captive screws using 3/8in-ratchet handle 23-31 Nm torque clutch P/N 74Y0985, 30cm (12in) socket extension, 5mm hex socket bit (PN 74Y0986),
- STEP 53 Carefully pull SAS cables through the Rail cable channels (see “D” in Figure 49) , towards the front of the Rack.

3.12 Install DE back into frame <= SSR Task

CAUTION: Do not remove or install this unit without using the provided lift tool. (C017)



DANGER: Hazardous voltage present. Voltages present constitute a shock hazard, which can cause severe injury or death. (L004)

- STEP 54 **Attention: Ensure that all the cables of the frame are clear** so that the Lift Tool table will not catch on cables as it is moved up and down across the face of the frame. Also ensure that the UEPO Panel is still out of the way.
- STEP 55 Using Battery powered drill shipped with the Lift Tool, 5/16 inch socket , ¼ inch drive adapter P/N 39F8449, raise the Lift Tool table until the DE is lined up with the frame location that it was removed from.
- STEP 56 Align the DE channels with the DE rail rollers and applying force to the cable tray, slide the DE back into the frame carefully. Be careful not to damage any cables.

ATTENTION: Do not push on any FRUs. Apply force only to the cable tray.

- STEP 57 Install the two Rear Rail Block Captive Allen head screws (see Figure 27).
- STEP 58 Attach the water hoses by pushing the quick connects onto the DE water connectors.
- STEP 59 Reconnect the rear SAS cables. Using the Location Codes labels, install the cables to the correct Port Card connectors. Each cable end should have two labels. The label closest to the connector (between the SN label and the connector) tells you the location to plug that end. The label on the other side of the SN label tells you where the other end of the cable is plugged. The convention for the label is like the location code of the port: <frame location> <card location><connector location>.

If velcro ties were removed, reinstall them.

When complete, all the Port Card connectors should be populated; there should be no open connectors.

- STEP 60 Close the rear door of the frame.
- STEP 61 Lower the Lift Tool, detach it from the frame, and store it.
- Retract the table extensions and stop plate extended in STEP 36 and STEP 37.
 - Detach the Lift Tool brackets that were installed in STEP 32. Be sure to completely disengage brackets from frame before attempting to move Lift Tool.
 - Using the battery powered drill lower the Lift Tool table to its lowest most stable position. Attention: Watch to ensure cables are clear during this operation!
 - Store the winch with Lift Tool for future use.

Power775 Disk Enclosure Rail Service Procedure

- STEP 62 If you removed the Front Rail Blocks, reinstall them using the Front Rail Block hex screws (see Figure 25).
NOTE: Make sure the Rail Blocks will not interfere with removal of the adjacent Drive Carriers

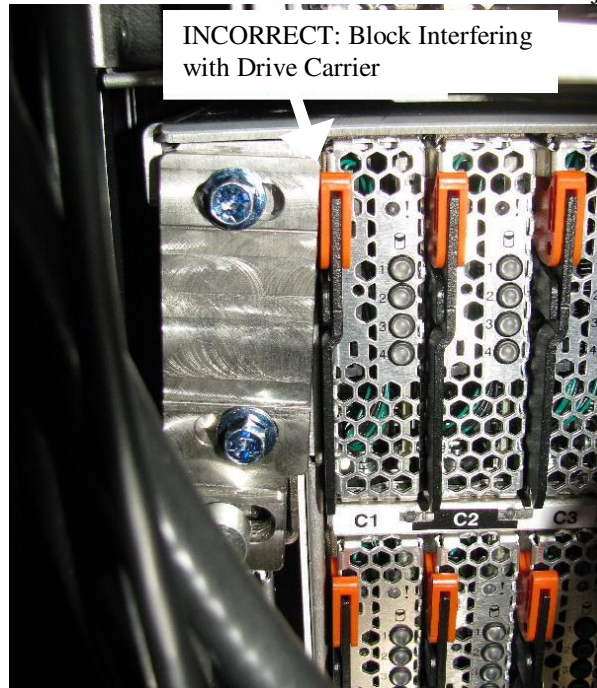

Figure 53: Rail Block Interfering with Drive Carrier

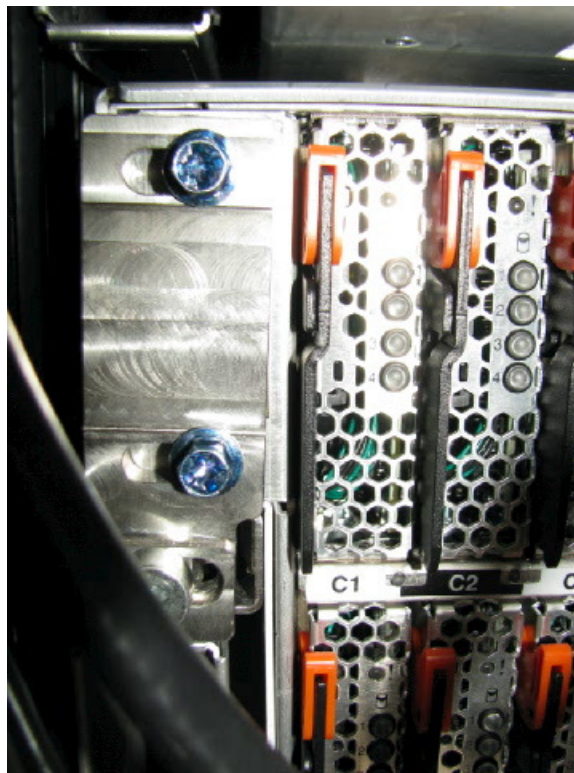

Figure 54: Rail Block Correctly Installed

Power775 Disk Enclosure Rail Service Procedure

- STEP 63 Install the two Front Rail Block Captive Allen head screws (one on the left side and one on the right side of the DE) (see Figure 25).
- STEP 64 Using the 2mm Hex Torque Driver P/N 74Y0983 with torque setting of 0.07Nm, reconnect the four DCCA Power Cables (HPICs) to the DE DCCAs.
- STEP 65 Reconnect the four DCCA Service Network Communications (E/NET) cables to the DE DCCAs (see Figure 20 and Figure 21).
- STEP 66 Reconnect the front SAS cables. Using the Location Codes labels, install the cables to the correct Port Card connectors. If velcro ties were removed, reinstall them.
- STEP 67 Reattach front door latch if removed in an earlier step.
- STEP 68 Reposition UEPO assembly if moved in an earlier step.
- STEP 69 Reattach and close the front door of the frame.

3.13 Store all tools. <= SSR TASK

- STEP 70 Return all hand tools to hand tool kit.
- STEP 71 Store the ladder.
- STEP 72 Store the Lift Tool and all other tools for future use.

3.14 Power on the Disk Enclosure <= CUSTOMER TASK

- STEP 73 If you are running AIX, remove the appropriate mpt2sas devices (those attached to the DE) from the Operating Systems owning the DE now before the DE is turned back on so that there is not time wasted in spinning down the drives.

If you are running Linux, no action is necessary.

- STEP 74 Power On the Disk Enclosure from the BPC FSP command line by using the following command:

This is the command syntax:

```
bpccmd -c 41<blank>0000<Cage ID>
```

```
<blank>      = "11"  
<Cage ID>    = see Figure 5
```

Type in the following, inserting the correct Cage ID for the DE you are servicing:

```
bpccmd -c 41110000xx
```

Where "xx" is the Cage ID of the DE you are servicing. This field will be 05,07,09,0B,0D, or 0F (see Figure 5).

The correct return code is 001100. If you do not receive this, contact the next level of support.

Power775 Disk Enclosure Rail Service Procedure

ATTENTION: Be very careful that you are in the correct frame and that you type this command exactly as it will power on the cage you type. If you are off by just one digit, you can easily power on a CEC or DE in another cage of the frame.

- STEP 75 Turn on the Disk Enclosure levels (5V and 12V) from the BPC FSP command line by using the following command:
This is the command syntax:

```
bpccmd -c 82<blank>0000<Cage ID>
```

```
<blank>      = "11"  
<Cage ID>    = see
```

Type in the following, inserting the correct Cage ID for the DE you are servicing:

```
bpccmd -c 82110000xx
```

Where "xx" is the Cage ID of the DE you are servicing. This field will be 05,07,09,0B,0D, or 0F (see Figure 5).

The correct return code is 001100. If you do not receive this, contact the next level of support.

- STEP 76 From the BPC FSP command line, make sure all the fans are functional with the following command:
"bpcmd -b -f"

If a fan is not functional, use "Power775 Disk Enclosure Fan Service Procedure" from InfoCenter and instead of replacing the fan, check to make sure that it is fully seated.

- STEP 77 Log out of ASM.

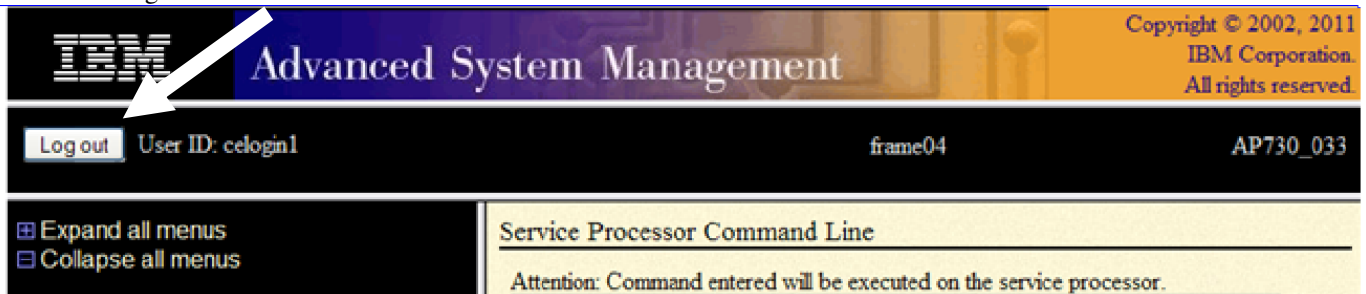

- STEP 78 If you are running AIX, wait until the Disk Enclosure is finished booting up (10 minutes will be sufficient) and then run "cfgmgr".
If you are running Linux, skip this step.
- STEP 79 You are now ready to turn GPFS back on.

3.15 Confirm with the customer <= SSR Task

- STEP 80 Confirm with the customer that the Disk Enclosure is fully operational and the problem has been fixed.

4 END OF POWER775 DISK ENCLOSURE RAILS SERVICE PROCEDURE

5 APPENDIX A: POWER775 BPC FSP COMMAND LINE PROCEDURE

5.1 Procedure to Access the BPC FSP Command Line

1. The HMC can be accessed via the keyboard/display that resides in the network management rack.
2. Login to the HMC if not done already.
3. In the HMC navigation pane, expand 'Systems Management' + sign and then click 'Frames':

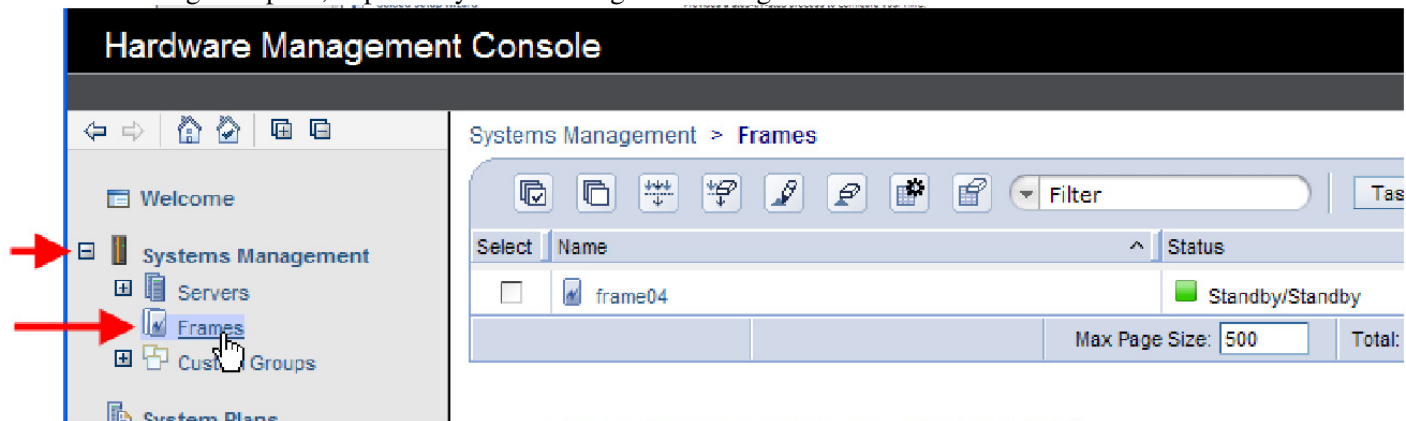

4. From the Tasks Menu right-arrow pull-down menu, click **Operations** → **Launch Frame Advanced Systems Management (ASM)**

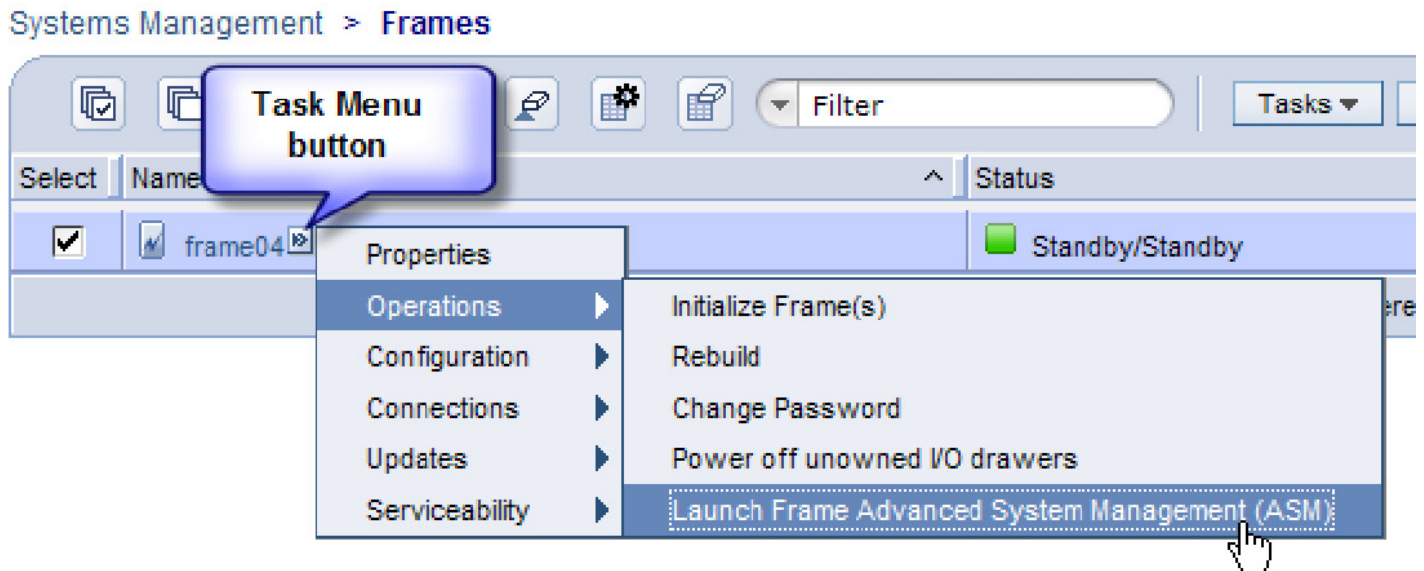

Power775 Disk Enclosure Rail Service Procedure

- From the Launch ASM Interface window, select **SIDE_A** for the 'Frame IP Address' then click the **OK** button.

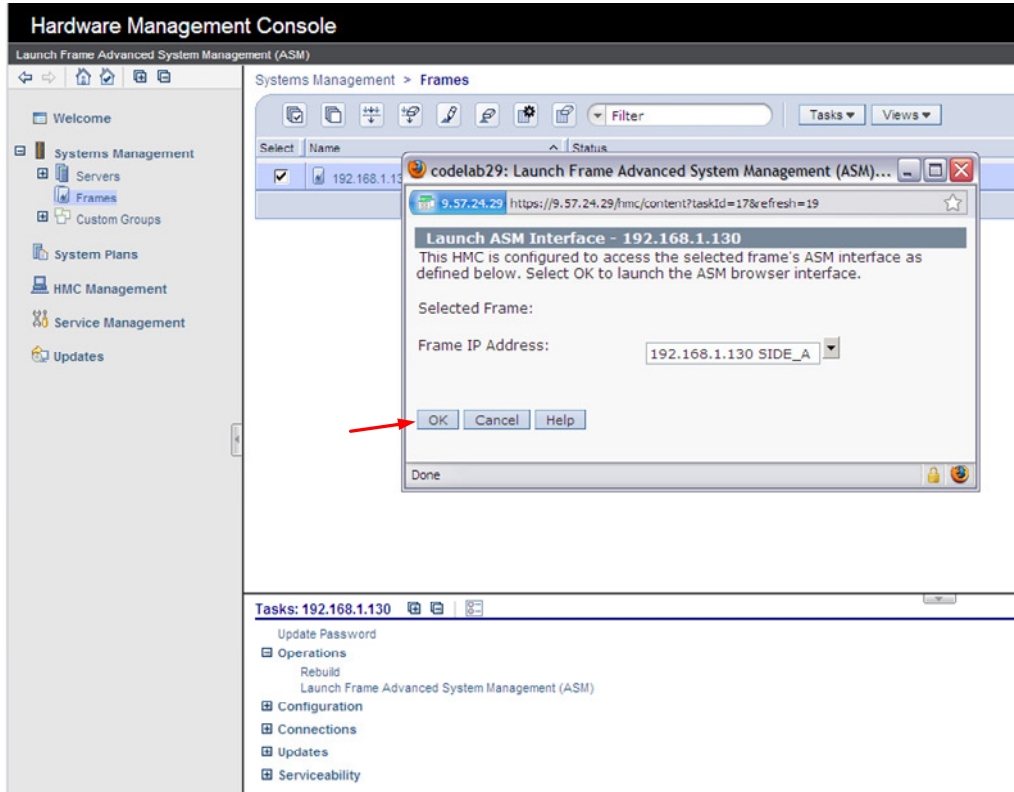

- The ASM login window is presented. Acquire the necessary User ID and Password.

“celogin” requires Daily PW from the IBM Support Center.

“celogin1” might be has enabled by the customer. If so, obtain the password from the customer.

- Enter User ID
- Enter Password
- Click **Log in** button

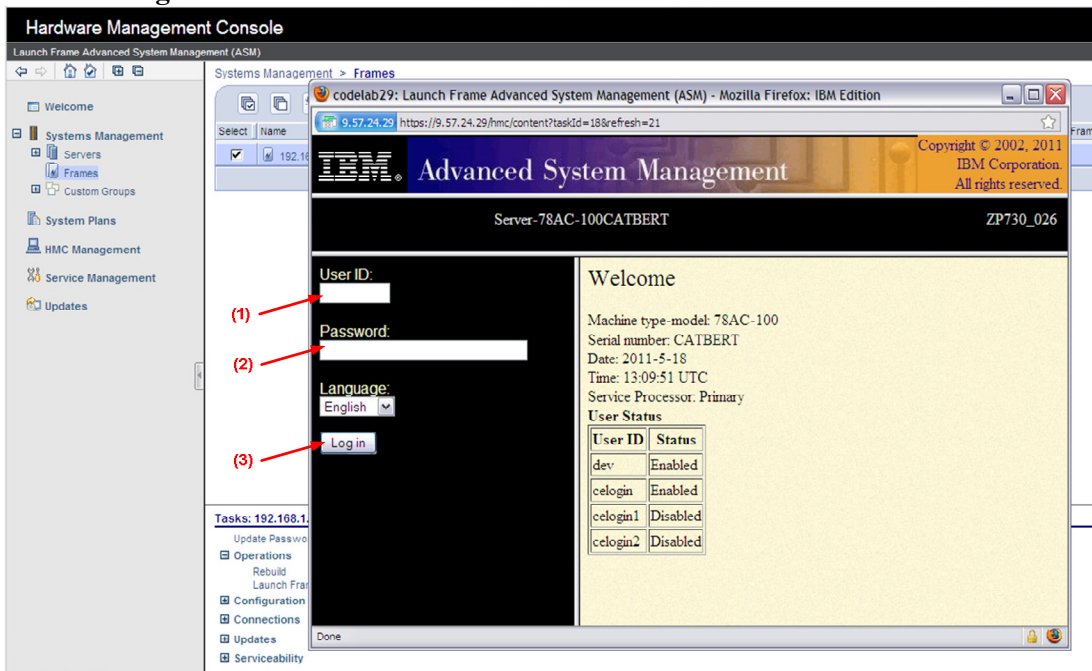

Power775 Disk Enclosure Rail Service Procedure

- Expand 'System Service Aids' + sign and Select 'Service Processor Command Line'.

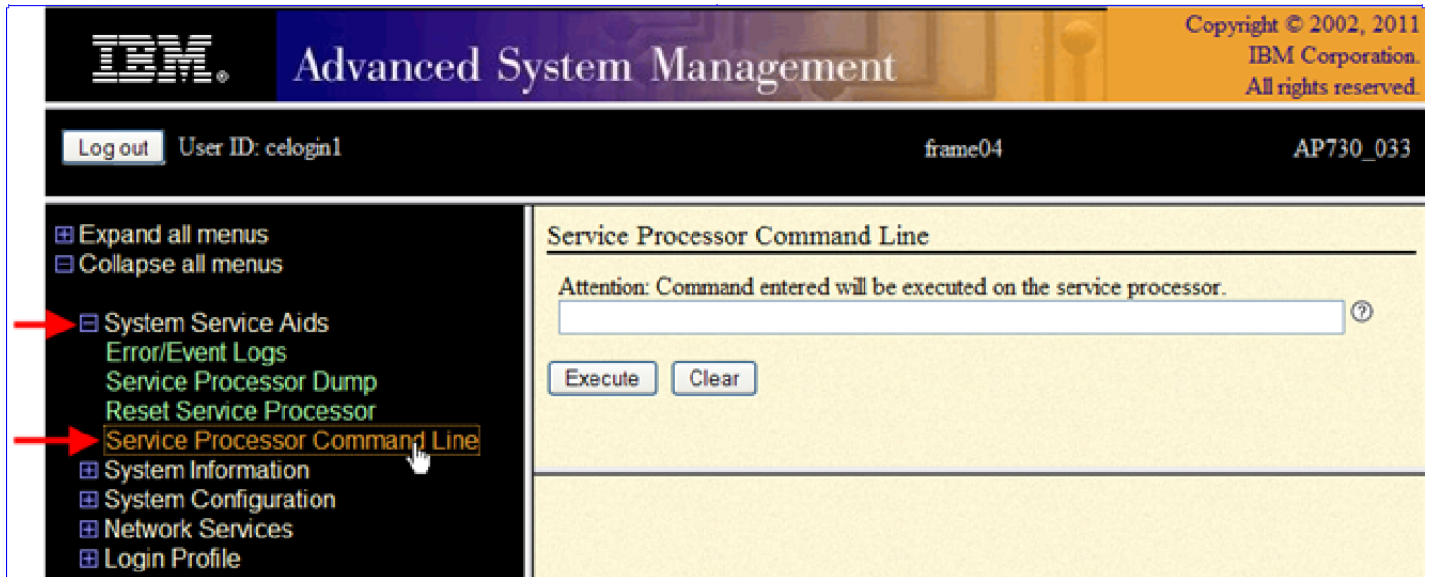

- The ASM BPC FSP Command line will be presented. Enter the commands defined in the paper service procedures at this command line and press the Enter key (or click the **Execute** button).
- Return to the step of the paper service procedure that directed you to this Appendix.

5.2 End of Appendix A: Power775 BPC FSP Command Line Procedure