

Power775
Distributed Converter and Control Assembly (DCCA) Power
Cable Service Procedure
Last Modified 10/6/2011



Power775 Distributed Converter and Control Assembly (DCCA) Power Cable Service
Procedure
PN: 41U8492, EC N44172

CONTENTS

1 GENERAL4

1.1 RELEASE / REVISION HISTORY.....4

1.2 WHERE TO FIND THIS DOCUMENT, AND CONTENTS OF THE PARENT PDF.....4

1.3 REQUIRED DOCUMENTS.....4

1.4 RELATED DOCUMENTS4

1.5 ABBREVIATIONS5

2 OVERVIEW6

2.1 SAFETY NOTICES6

2.2 FILE SYSTEM RISK STATEMENT.....6

2.3 CONFIRM HOW YOU GOT TO THIS POWER 775 DISTRIBUTED CONVERTER AND CONTROL ASSEMBLY (DCCA)
POWER CABLE SERVICE PROCEDURE6

2.4 DISTRIBUTED CONVERTER AND CONTROL ASSEMBLY (DCCA) POWER CABLE DESCRIPTION7

2.5 BACKGROUND7

2.6 CONCURRENCY8

2.7 DISTRIBUTED CONVERTER AND CONTROL ASSEMBLY (DCCA) POWER CABLE WEIGHT.....8

2.8 REQUIRED SSRs AND ROLES8

2.9 ESTIMATED SERVICE TIME9

2.10 P7IH HAND TOOL KIT REQUIRED TOOLS.....9

2.11 PREREQUISITES FOR THIS PROCEDURE9

2.12 OVERVIEW OF PROCEDURE.....9

3 SERVICE PROCEDURE.....10

3.1 IDENTIFY CEC DRAWER OR DISK ENCLOSURE REQUIRING POWER CABLE SERVICE <= SSR TASK.....10

3.2 REMOVAL OF MECHANICALS AND DCCA POWER CABLE <= SSR TASK.....15

3.3 RE-INSTALLATION OF MECHANICALS AND INSTALLATION OF NEW DCCA POWER CABLE <= SSR TASK.....24

**4 END OF POWER775 DISTRIBUTED CONVERTER AND CONTROL ASSEMBLY POWER CABLE
SERVICE PROCEDURE28**

5 APPENDIX A: POWER775 BPC FSP COMMAND LINE PROCEDURE.....29

5.1 PROCEDURE TO ACCESS THE BPC FSP COMMAND LINE29

5.2 END OF APPENDIX A: POWER775 BPC FSP COMMAND LINE PROCEDURE31

Power775 Distributed Converter and Control Assembly (DCCA) Power Cable Service Procedure

PN: 41U8492, EC N44172

Figure List

Figure 1 DCCA Power Cable Locations	7
Figure 2 Typical Raceway Cross Section.....	8
Figure 3 Identify LED Selection	11
Figure 4 System Unit, Model F2C Selection.....	11
Figure 5 DCCA Identify LED Selection	12
Figure 6 Disk Enclosure HEX Cage ID	13
Figure 7 CEC Drawer HEX Cage ID	17
Figure 8 TT Chart for Static Circuit Breaker Translation	18
Figure 9 Disk Enclosure DCCA cable connections.....	19
Figure 10 UEPO Service Position	20
Figure 11 Remove Cover Latch Bracket.....	20
Figure 12 Backshell.....	21
Figure 13 Raceway Retention Screw	22
Figure 14 UPIC Raceway Removal	22
Figure 15 DCCA Power Cable Raceway Removal	23
Figure 16 DCCA Power Cable Removal	23
Figure 17 BPE Mounting Bracket Removal.....	24

Table List

Table 1 Release / Revision History	4
Table 2 Required Documents	4
Table 3 Related Documents	4
Table 4 Abbreviations	5

1 GENERAL

1.1 Release / Revision History

Document Name	Date	PDF name	Description
Power775 Distributed Converter and Control Assembly Power Cable Service Procedure	10/6/2011	"p775_dcca_pwr_cable.pdf"	Initial Release

Table 1 Release / Revision History

1.2 Where to find this document, and contents of the parent PDF

The current Power775 Distributed Converter and Control Assembly Power Cable Service Procedure document is "p775_dcca_pwr_cable.pdf" which is to be downloaded from:

InfoCenter Website: <http://publib.boulder.ibm.com/infocenter/powersys/v3r1m5/topic/p7ee2/p7ee2kickoff.htm>

Click "PDF files for the IBM Power 775 (9125-F2C) removing and replacing parts"

Under "Frame Power Components", click "Power775 Distributed Converter and Control Assembly Power Cable Service Procedure" to download PDF "p775_dcca_pwr_cable.pdf"

This is the only valid source for the latest Power775 Distributed Converter and Control Assembly Power Cable Service Procedure.

1.3 Required Documents

Document	Doc Number	Location
Safety Notices http://publib.boulder.ibm.com/infocenter/powersys/v3r1m5/topic/p7hdx/G229-9054.pdf	Doc# G229-9054	InfoCenter *

Table 2 Required Documents

*InfoCenter Website: <http://publib.boulder.ibm.com/infocenter/powersys/v3r1m5/topic/p7ee2/p7ee2kickoff.htm>

1.4 Related Documents

Document	Doc Number	Location
"GPFS Native RAID Administration and Programming Reference"	SA23-1354	InfoCenter *

Table 3 Related Documents

*InfoCenter Website: <http://publib.boulder.ibm.com/infocenter/powersys/v3r1m5/topic/p7ee2/p7ee2kickoff.htm>

Power775 Distributed Converter and Control Assembly (DCCA) Power Cable Service
 Procedure
 PN: 41U8492, EC N44172

1.5 Abbreviations

Abbreviation	Definition	Details
CEC	Central Electronic Complex	Also referred to as the node.
DCCA	Distributed Conversion and Control Assembly	The power supplies for the CEC and DE are called the CEC DCCA and DE DCCA respectively.
DE	Disk Enclosure	
GPFS	Global Parallel File System	IBM's file system utilizing software RAID
HDD	Hard Disk Drive	This also means hard drive
LED	Light Emitting Diode	
PCB	Printed Circuit Board	
RAID	Redundant Array of Inexpensive Disks	
SAS	Serial Attached SCSI	Protocol used for direct attached storage
SCB	Static Circuit Breaker	Port on BPD that controls 350V to power cables
SSR	System Service Representative	IBM Service personnel
SSD	Solid State Drive	
UEPO	Unit Emergency Power Off	
UPIC	Universal Power Interface Cable	Power Cable for WCU

Table 4 Abbreviations

2 OVERVIEW

This section is an overview only. Do not start the service procedure until Section 3 which contains the detailed steps.

2.1 Safety Notices

Read “Safety_Notices “ available from InfoCenter at this link:
<http://publib.boulder.ibm.com/infocenter/powersys/v3r1m5/topic/p7hdx/G229-9054.pdf>

The following cautions apply to all Power775 service procedures:

CAUTION:

Energy hazard present. Shorting might result in system outage and possible physical injury. Remove all metallic jewelry before servicing. (C001)

CAUTION:

The doors and covers to the product are to be closed at all times except for service by trained service personnel. All covers must be replaced and doors locked at the conclusion of the service operation. (C013)

CAUTION:

Service of this product or unit is to be performed by trained service personnel only. (C032)

The following notices specifically pertain to this Power775 service procedure.



DANGER: Hazardous voltage present. Voltages present constitute a shock hazard, which can cause severe injury or death. (L004)

2.2 File System Risk Statement

The Global Parallel File System (GPFS) implementation of software RAID stripes data across all the Disk Enclosures in the cluster. **If servicing a CEC Drawer supporting a Service Node and ALL Power Cables are powered down at the same time, then all Disk Enclosures running off of this service node will go into panic and become unavailable. If servicing a CEC Drawer supporting a GPFS node and ALL Power Cables are powered down at the same time then the file system will go into panic and become unavailable. To avoid this situation you must migrate the drawers to be served by other nodes/CEC Drawers.**

2.3 Confirm how you got to this Power 775 Distributed Converter and Control Assembly (DCCA) Power Cable Service Procedure

You should be performing this procedure if: An SRC directed you to replace a DCCA Power Cable

You should have downloaded this procedure from:

InfoCenter Website: <http://publib.boulder.ibm.com/infocenter/powersys/v3r1m5/topic/p7ee2/p7ee2kickoff.htm>

This is the only valid source for the latest Power775 Distributed Converter and Control Assembly (DCCA) Power Cable Service Procedure

2.4 Distributed Converter and Control Assembly (DCCA) Power Cable Description

Referring to Figure 1 below showing the system front cover open, DCCA Power Cables are located in front of each CEC drawer (or Disk Enclosure), and terminate in the top/front of the system on each Bulk Power Distribution(BPD) unit. The DCCA Power Cables supply 350V to the CEC Drawer and DE.

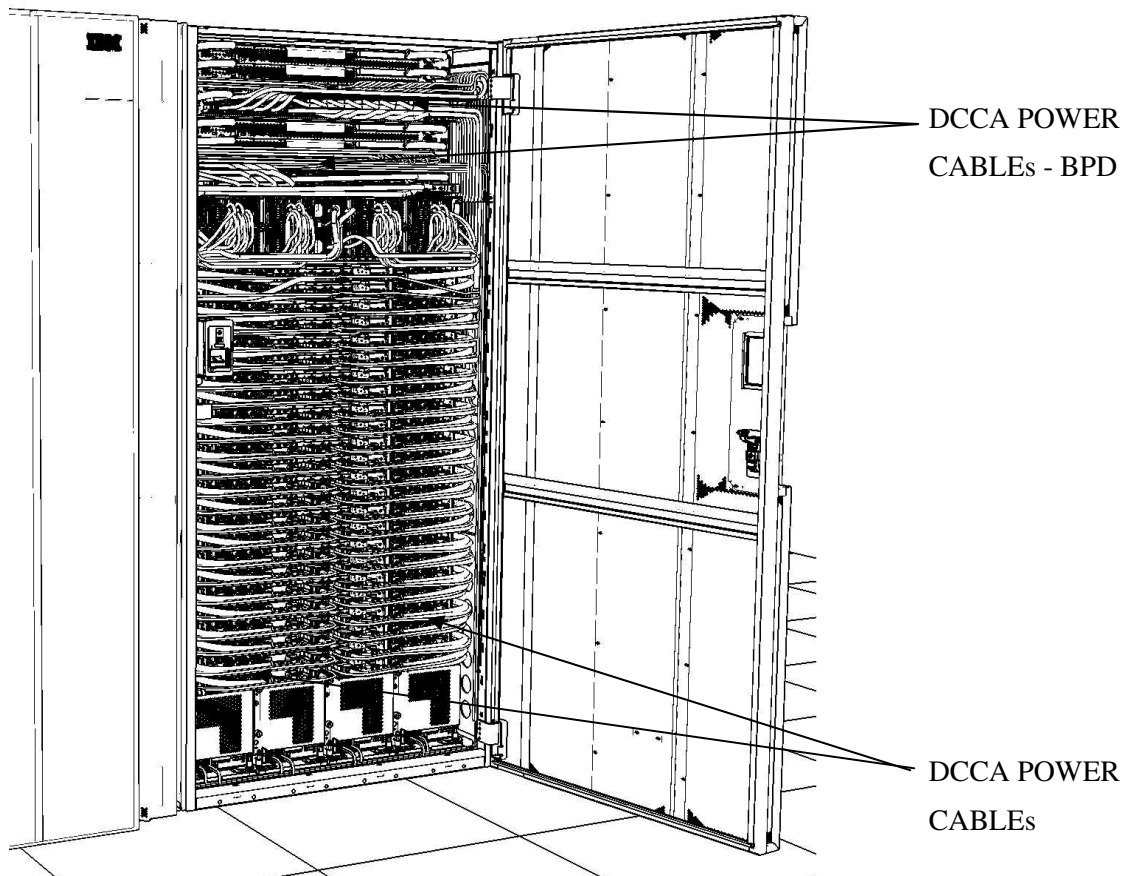

Figure 1 DCCA Power Cable Locations

2.5 Background

All DCCA Power Cables are located in the front of the rack. For each CEC drawer or DE, there are four DCCA Power Cables which carry voltage from the BPD at the top of the system, to each of the CEC Drawers or DE two Distributed Converter & Control Assemblies (DCCAs). Each Disk Enclosure also has four DCCA Power Cables which connect the BPD to each of the two Distributed Converter Assemblies (DCCAs). In order to manage the potentially large cable bulk in the rack, these 1/2" diameter cables require a specific routing and placement within cable management raceways which are nested in the sides of the rack. This cable management approach ensures that the drawers can be serviced in the future with minimal interference with adjacent cables, while controlling the cable paths allowing the front cover to close properly. The cable raceways consist of 3 major sections: 1) long (drawer location 5, 7, 9, 11), 2) medium (drawer location 13, 15, 17, 19), and 3) short (drawer location 21, 23, 25, 27). Cables for the top disk enclosure (drawer location 29), do not reside in the raceways. Raceways are located on both the left and right sides of the rack. Cables exiting the CEC Drawers or DE on the right side of the rack terminate to the upper BPD. Cables exiting the CEC Drawers or DE on the left will terminate to the lower BPD. Each raceway has 4 slots (one slot per CEC or DE). Each slot manages cables for one CEC or DE. Within a raceway slot, there are 4 cable positions, 2 positions for smaller communications cables at the base, and 2 positions above

Power775 Distributed Converter and Control Assembly (DCCA) Power Cable Service Procedure

PN: 41U8492, EC N44172

them for the DCCA Power Cables. These cables are snapped into the plastic fingers and held in place by grooves within the fingers. To properly fit within the raceway, all cables must be placed in their exact position with no twists or kinks. See Figure 2 below for typical placement. Because the raceways are nested along the sides of the rack behind the front faces of the drawers, the entire raceway (with cables) must be shifted forward and partially removed until the defective cable can be located and replaced.

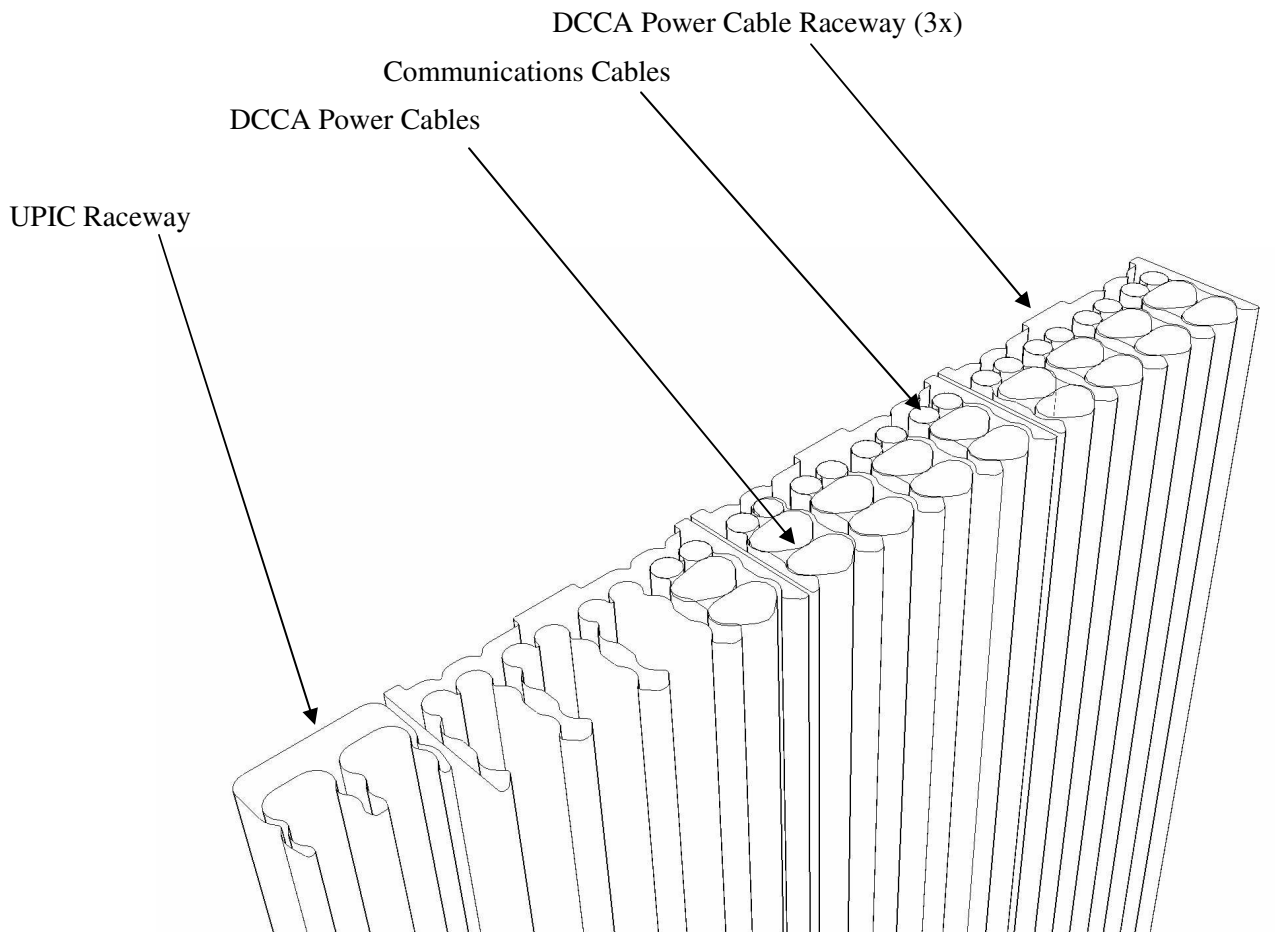

Figure 2 Typical Raceway Cross Section

2.6 Concurrency

The DCCA Power Cables are concurrently maintainable.

2.7 Distributed Converter and Control Assembly (DCCA) Power Cable Weight

DCCA Power Cables weigh 1.3 to 2.6 lbs (0.59 to 1.18 kg) depending on their length. A populated raceway with cables can weigh up to 12 lbs (5.44 kg).

2.8 Required SSRs and Roles

This service procedure requires 1 SSR.

Power775 Distributed Converter and Control Assembly (DCCA) Power Cable Service
Procedure
PN: 41U8492, EC N44172

2.9 Estimated Service Time

It can take up to 2 hours to perform this procedure depending on the particular cable requiring service.

2.10 P7IH Hand Tool Kit Required Tools

- 4mm Hex Driver (1.5-1.75 Nm torque setting) PN 41V1059*
- 2mm hex driver (P/N 74Y0983)
- 3/8" drive ratchet (P/N 6428140) depending on the cable location **
- 3/8" drive extension (P/N 46K2707) **
- 5mm hex socket bit (P/N 74Y0986) **
- Torque clutch (P/N 74Y0985) **
- 3/8" drive 16mm socket (P/N 5497568) **
- Velcro puck (P/N 31L7174)

* 4mm hex driver not required if servicing cables on the right side of the system

** These tools are only required when servicing cables for drawers in lower rack slots 5 through 11 (first four lower CEC drawers or DEs)

2.11 Prerequisites for this Procedure

In order to perform this procedure, you will need the following information:

- 1) The location code of the FRU to be serviced
 - 2) The cage location of the FRU to be serviced
 - 3) The frame number and frame serial number of the frame containing the FRU to be serviced
-

2.12 Overview of Procedure

This is an overview of the tasks to be performed. Read this overview but do not perform any of the tasks yet.

3.1	IDENTIFY CEC DRAWER OR DISK ENCLOSURE REQUIRING POWER CABLE SERVICE <= SSR TASK	10
3.2	REMOVAL OF MECHANICALS AND DCCA POWER CABLE <= SSR TASK	15
3.3	RE-INSTALLATION OF MECHANICALS AND INSTALLATION OF NEW DCCA POWER CABLE <= SSR TASK	24

3 SERVICE PROCEDURE

STOP – Do not proceed unless you have read “G229-9054.pdf” which is available from InfoCenter; see Section 1.3.

3.1 Identify CEC Drawer or Disk Enclosure requiring Power Cable Service <= SSR TASK



DANGER: Hazardous voltage present. Voltages present constitute a shock hazard, which can cause severe injury or death. (L004)

STEP 1 Determine with the customer which is the primary HMC that manages the Frame and CEC Drawer or DE to be serviced.

Note: The HMC can be accessed via the keyboard/display that resides in the management rack or by plugging a laptop into the BPCH of the rack where the service will be performed.

STEP 2 In the Navigation menu on the HMC, expand **Systems Management** then select **Servers**

Are you are servicing a cable on a CEC Drawer?

If Yes, then perform STEP 3 to STEP 6, then skip to STEP 8

If No(performing cable service on a DE), then skip to STEP 7

STEP 3 Place a checkmark in the Select column of the CEC Drawer that you want to flash the DCCA Identify LED on. You will flash the DCCA Identify LED to verify that you are servicing the appropriate Power Cable.

Power775 Distributed Converter and Control Assembly (DCCA) Power Cable Service
Procedure
PN: 41U8492, EC N44172

STEP 4 From the **Tasks** menu *select* **Operations -> LED Status -> Identify LED**. See Figure 3.

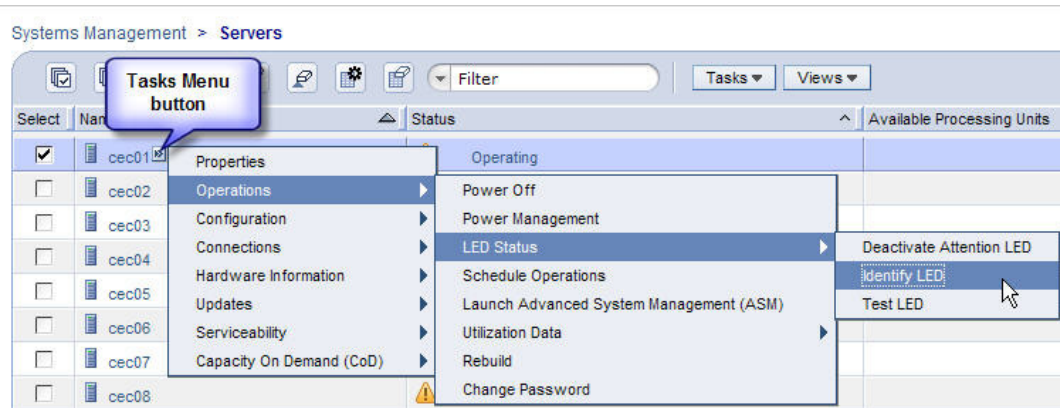

Figure 3 Identify LED Selection

STEP 5 In the window titled **Identify LED**, *select* **Enclosure select System Unit, Model F2C** then *click* the **List FRUs...** button. See Figure 4.

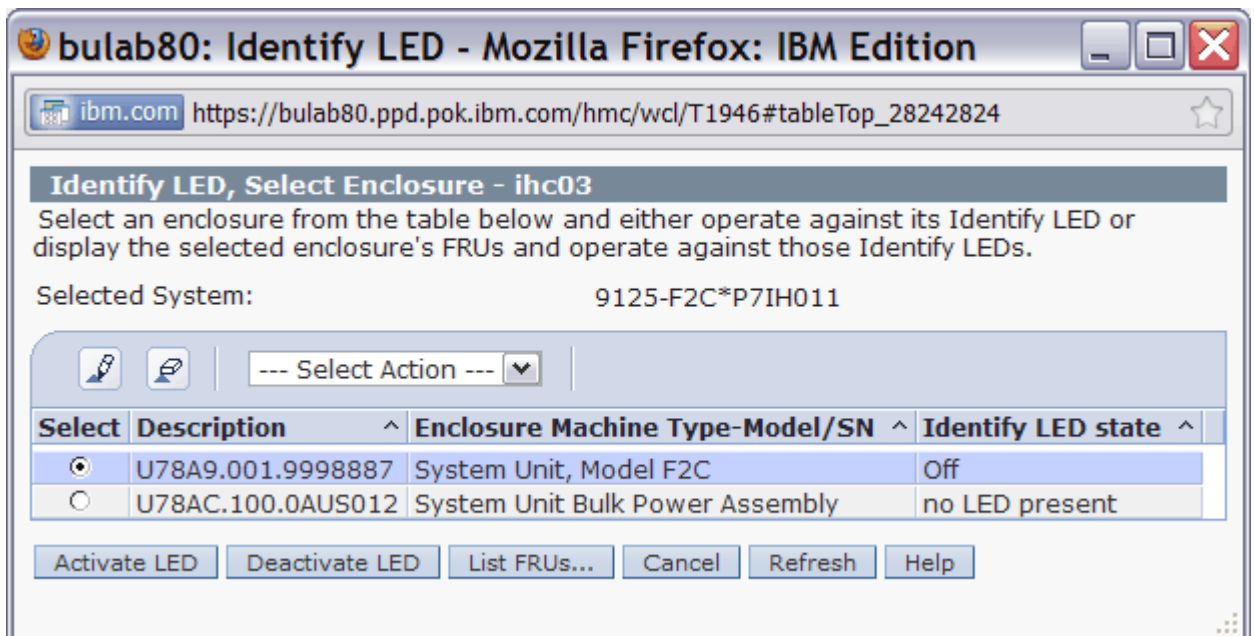

Figure 4 System Unit, Model F2C Selection

Power775 Distributed Converter and Control Assembly (DCCA) Power Cable Service
 Procedure
 PN: 41U8492, EC N44172

STEP 6 To flash the CEC Drawer DCCA Identify LED and UEPO switch: In the window **Identify LED, Select Location**, place a checkmark in the Select column for the DCCA Location Code requiring power cable service and then *click* the **Activate LED** button. Figure 5 shows the example of flashing the DCCA Identify LED in **U78A9.001.[Serial#]-P1-C147** : this is the top DCCA in the CEC Drawer. To select lower DCCA of the CEC Drawer you would select **U78A9.001.[Serial#]-P1-C148**. Skip to STEP 8.

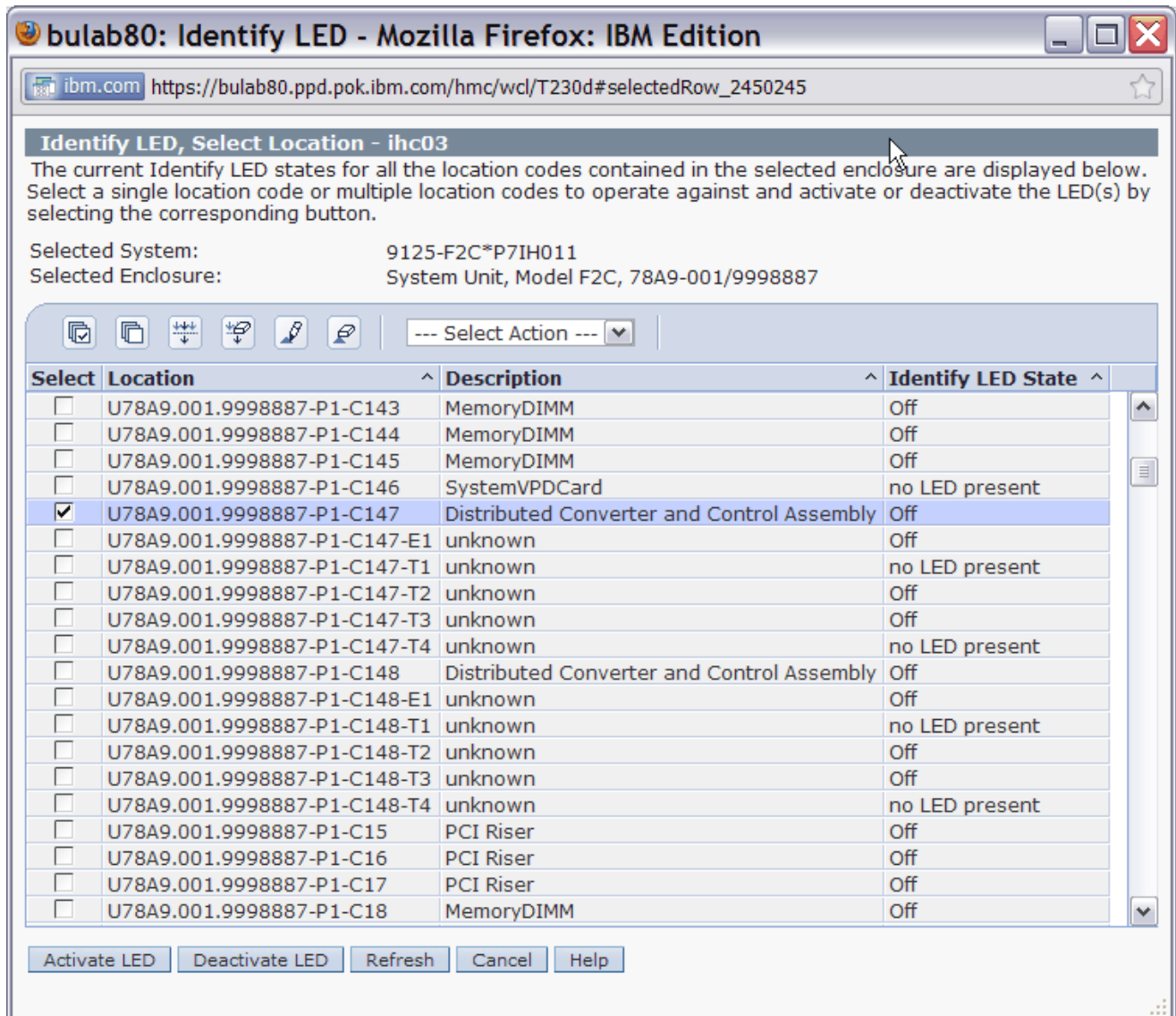

Figure 5 DCCA Identify LED Selection

Power775 Distributed Converter and Control Assembly (DCCA) Power Cable Service Procedure

PN: 41U8492, EC N44172

STEP 7 To flash the DE DCCA Identify LED and UEPO switch, use the procedure “Appendix A: Power775 BPC FSP Command Line Procedure” (included in Section 5 of this document) to access the BPC FSP command line, and issue the following command:

```
bpccmd -c 27110000<CageID><FF>02
```

Where CageID is the 2 character Hex value for the Disk Enclosure(Figure 6).

FF is the fru id, it is 90 for DCCA1 and 91 for DCCA2

For Disk Enclosures:

DCCA1 is the left DCCA - 90

DCCA2 is the right DCCA – 91

A successful return code is: ‘001100’. If you do not receive a successful return code, contact next level of support.

Example:

```
bpccmd -c 271100000f9002
```

Executes the command on DCCA1(left DCCA) of the DE installed in Cage 0f

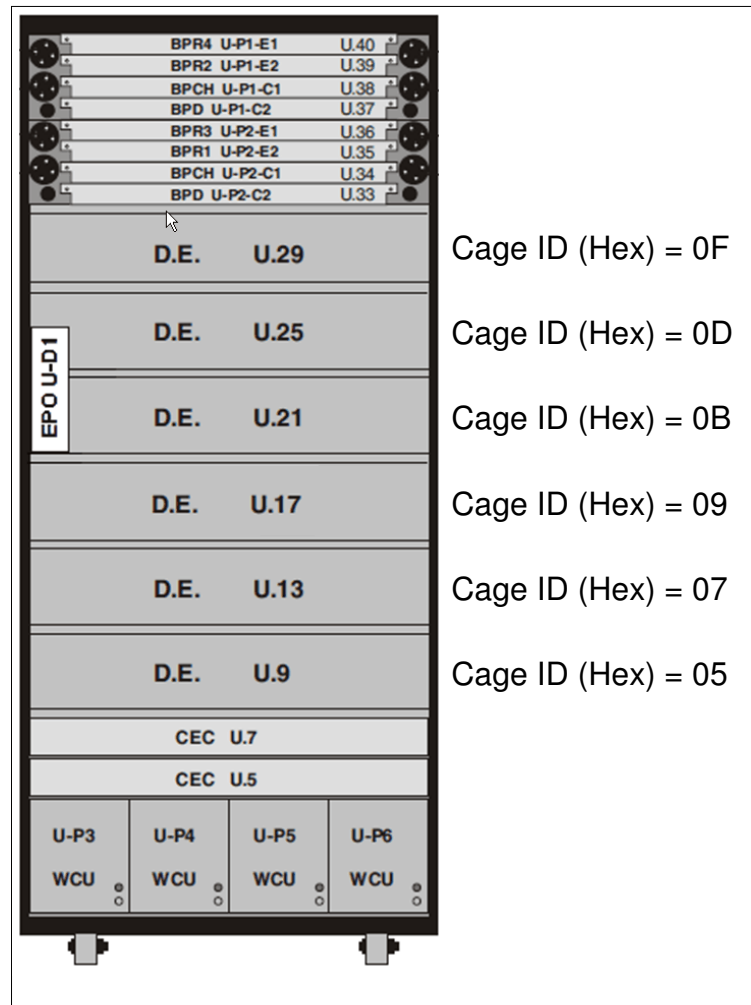

Figure 6 Disk Enclosure HEX Cage ID

Power775 Distributed Converter and Control Assembly (DCCA) Power Cable Service Procedure

PN: 41U8492, EC N44172

STEP 8 Locate and confirm the Frame selected now has a flashing UEPO Switch Identify LED and is the frame you plan to perform a service action on.

STEP 9 After locating the Frame that requires the service

- a) Open the front door
- b) Verify the Frame and CEC Drawer or DE serial numbers to ensure the correct location
- c) For a CEC Drawer, verify the DCCA Communications Port ID LED is flashing that requires cable service. For a DE, verify the DCCA Identification LED is flashing for the DCCA that requires cable service.

3.2 Removal of Mechanicals and DCCA Power Cable <= SSR TASK

STEP 10 After identifying the DCCA Power Cable that requires service, deactivate the BPD port that provides power to this DCCA Power Cable. You should use BPC ASM from the A side BPA if replacing a cable on the left side of the frame, but use BPC ASM from the B side BPA if replacing a cable on the right side of the frame. Use BPC ASM to deactivate the BPD port using the following command format:

```
bpccmd -c 10ee0000ff<FF><TT>
```

FF is the fru id, it is 81 for the A side BPA(lower BPA) and C1 for B side BPA(upper BPA)

For CEC Drawers:

T1 DCCA port Power Cables are on the A side BPA - 81

T4 DCCA port Power Cables are on the B side BPA - C1

For Disk Enclosures Drawers, see Figure 9:

T1 DCCA port Power Cables are on the A side BPA - 81

T4 DCCA port Power Cables are on the B side BPA - C1

All T1 DCCA port Power Cables route to the left of the frame to the A side BPA.

All T4 DCCA port Power Cables route to the right of the frame to the B side BPA.

TT is the BPD Static Circuit Breaker(SCB) connector id: 01 to 1A.

Use Figure 8 to determine the correct TT value.

For CEC Drawer DCCAs you must determine the Cage ID(Node ID) from Figure 7 based on which CEC Drawer is being serviced. Then determine the TT value by identifying the SCB connector ID from Figure 8. Viewing Figure 8 complete the following:

- A. Find region of chart corresponding to the DCCA you are servicing, remember that the top unit is DCCA1 and the bottom unit is DCCA2. Use the column labeled as “Node DCA”.
- B. Then find the row of the chart(within the DCCA1 or DCCA2 region) that corresponds to the CEC Drawer Cage ID in the column labeled as “Node ID”
- C. Using the row identified in above in “B”, identify the appropriate TT value listed in the SCB column.

Example:

CEC Drawer DCCA1, Cage ID 03 would be the top row and the TT value for the SCB is “01”

For Disk Enclosure DCCAs you must determine the Cage ID(Disk Enclosure ID) from Figure 6 based on which DE is being serviced. Then determine the TT value by identifying the SCB connector ID from Figure 8. Viewing Figure 8 complete the following:

Power775 Distributed Converter and Control Assembly (DCCA) Power Cable Service Procedure

PN: 41U8492, EC N44172

- A. Find region of chart corresponding to the DCCA you are servicing, remember that the left unit is DCCA1 and the right unit is DCCA2. Use the column labeled as “Disk Enclosure DCA”.
- B. Then find the row of the chart(within the DCCA1 or DCCA2 region) that corresponds to the DE Cage ID in the column labeled as “Disk Enclosure ID”
- C. Using the row identified in above in “B”, identify the appropriate TT value listed in the SCB column.

Example:

DE DCCA2, Cage ID 0F would be the bottom row and the TT value for the SCB is “1A”

A successful return code is: ‘00EE00’. If you do not receive a successful return code, contact next level of support. Note: Even if the green LED indicating 350V power present on the DCCA is not on prior to sending the command, you must execute the command defined in this step. The reason is that the power cable may have a defect and power might still be enabled on the BPD SCB. An additional note is that if the BPD port was already turned off before the service action started you might get a bad return code.

Example:

```
bpccmd -c 10ee0000ff8101
```

Executes the power deactivation command for the power cable attached to the bottom CEC Drawer (in U.5) for the T1(left DCCA port - 81) in the top DCCA(DCCA1 - 01)

Power775 Distributed Converter and Control Assembly (DCCA) Power Cable Service
 Procedure
 PN: 41U8492, EC N44172

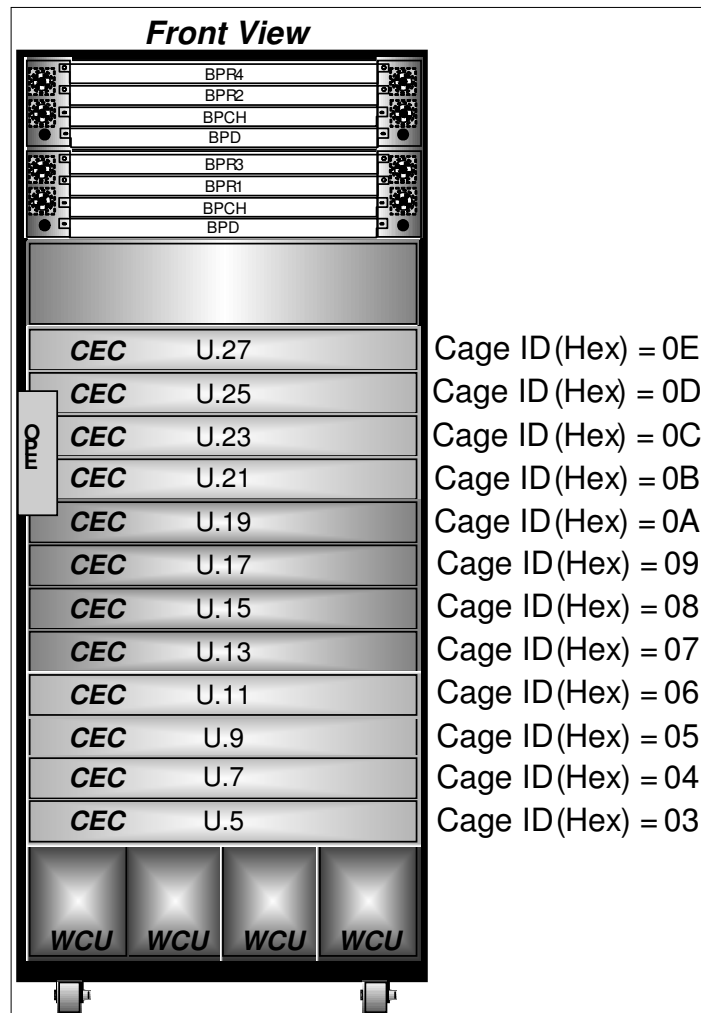

Figure 7 CEC Drawer HEX Cage ID

Figure 8 shows details regarding Power Cable connections. The Connector column tells the Power Cable plug location for the BPD connection, while the SCB column shows the data that you will use as the TT portion in the procedure in STEP 10. Node ID is the same as Cage ID (Hex) for the CEC Drawer from Figure 7 and Node DCA column corresponds to the CEC Drawer DCCA(1 for top, 2 for bottom). Disk Enclosure ID is the same as Cage ID (Hex) for the Disk Enclosure from Figure 6 and Disk Enclosure DCA column corresponds to the DE DCCA(1 for left, 2 for right).

Power775 Distributed Converter and Control Assembly (DCCA) Power Cable Service
 Procedure
 PN: 41U8492, EC N44172

Row	FRU ID		Connector	SCB	Node		Disk Enclosure	
	A side	B side			ID	DCA	ID	DCA
1	81	C1	T1	01	03	1		
1	81	C1	T2	02	04	1		
1	81	C1	T3	03	05	1	05	1
1	81	C1	T4	04	06	1		
1	81	C1	T5	05	07	1	07	1
1	81	C1	T6	06	08	1		
1	81	C1	T7	07	09	1	09	1
1	81	C1	T8	08	0A	1		
1	81	C1	T9	09	0B	1	0B	1
1	81	C1	T10	0A	0C	1		
1	81	C1	T11	0B	0D	1	0D	1
1	81	C1	T12	0C	0E	1		
1	81	C1	T13	0D			0F	1
2	81	C1	T14	0E	03	2		
2	81	C1	T15	0F	04	2		
2	81	C1	T16	10	05	2	05	2
2	81	C1	T17	11	06	2		
2	81	C1	T18	12	07	2	07	2
2	81	C1	T19	13	08	2		
2	81	C1	T20	14	09	2	09	2
2	81	C1	T21	15	0A	2		
2	81	C1	T22	16	0B	2	0B	2
2	81	C1	T23	17	0C	2		
2	81	C1	T24	18	0D	2	0D	2
2	81	C1	T25	19	0E	2		
2	81	C1	T26	1A			0F	2

Figure 8 TT Chart for Static Circuit Breaker Translation

Power775 Distributed Converter and Control Assembly (DCCA) Power Cable Service
Procedure
PN: 41U8492, EC N44172

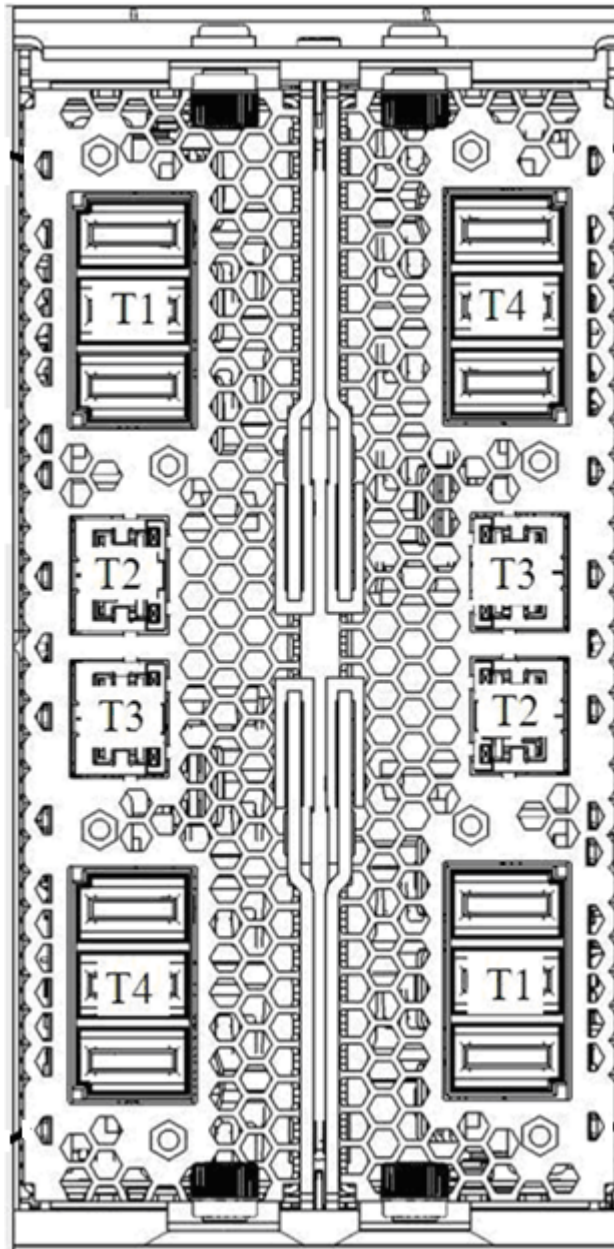

Figure 9 Disk Enclosure DCCA cable connections

- STEP 11 If servicing a DCCA Power Cable that is routed on the left side of the Frame:
- a) Reposition the UEPO to the upper service position. This provides adequate service clearance to manipulate cables.
 - a. Using 4mm hex driver 41V1059, fully loosen the blue captive retention screw at the base of the UEPO chassis.
 - b. Leaving the cables attached and switch in the on position, shift the unit upward to disengage it from the rack

Power775 Distributed Converter and Control Assembly (DCCA) Power Cable Service Procedure

PN: 41U8492, EC N44172

- c. Reattach the UEPO Switch in the upper left corner of the rack in the service/shipping position. (see Figure 10).
- b) Remove the cover latch bracket on the left vertical rack member using the 4mm hex driver 41V1059. (See Figure 11)

Upper UEPO Mounting Bracket

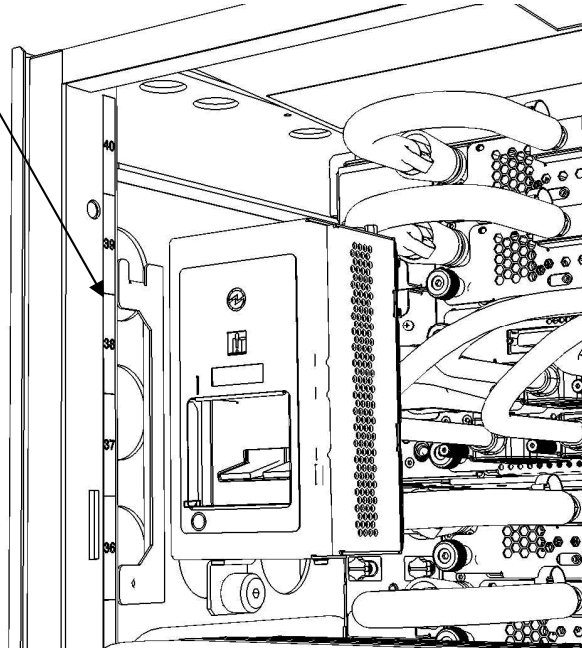

Figure 10 UEPO Service Position

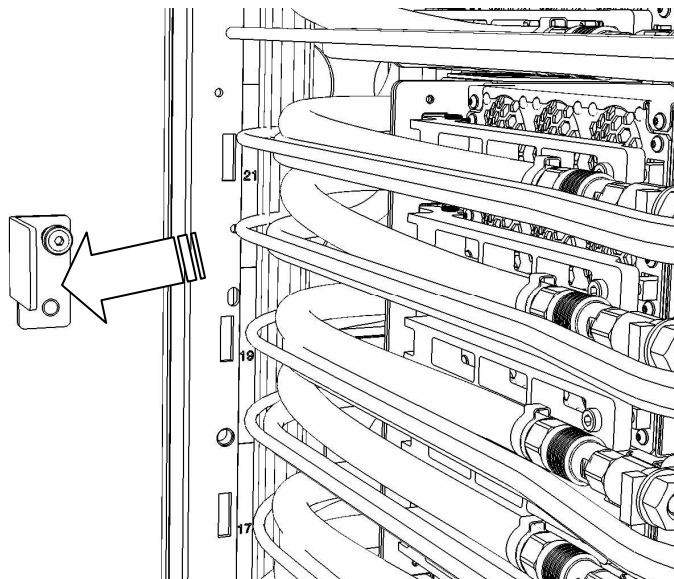

Figure 11 Remove Cover Latch Bracket

Power775 Distributed Converter and Control Assembly (DCCA) Power Cable Service Procedure

PN: 41U8492, EC N44172

- STEP 12 Unplug the target DCCA Power Cable from the DCCA
- Determine the exact power cable requiring replacement.
 - Verify the green LED for the DCCA Power Cable that indicates 350VDC present is OFF, otherwise you risk unplugging a connector with power active.
 - Unplug the DCCA Power Cable from the CEC DCCA (or Disk Enclosure DCCA) using 2mm hex driver 74Y0983 to unseat the jack screws.
 - Record the information on the plugging designation label from the backshell for future reference. (see photo in Figure 12 below)



Figure 12 Backshell

- STEP 13 Remove Velcro strap securing power cable to front of CEC Drawer or DE.
- Because CEC drawers and Disk Enclosures are populated from the bottom up within the rack, cables for the lower CEC Drawers and DEs are nested further back along the sides of the rack, As a result, some raceways will have to be shifted forward and removed from the rack to locate and replace the desired power cable.

Power775 Distributed Converter and Control Assembly (DCCA) Power Cable Service Procedure

PN: 41U8492, EC N44172

STEP 14 Remove the DCCA Power Cable raceway for the target cable:

- a) Loosen the UPIC raceway retention bracket screw using the ¼” drive ratchet and 7mm socket and slide screw and bracket forward (see photos in Figure 13 below).
- b) Shift the UPIC raceway upward, then remove it from the rack (see photo in Figure 14).



Figure 13 Raceway Retention Screw



Figure 14 UPIC Raceway Removal

Power775 Distributed Converter and Control Assembly (DCCA) Power Cable Service
Procedure
PN: 41U8492, EC N44172

STEP 15 Once the UPIC raceway has been removed, slide the first DCCA Power Cable raceway forward until it disengages from the mounting slots. It can then be removed from the rack. Repeat this process until the desired cable is located (see photos in Figure 15 below).

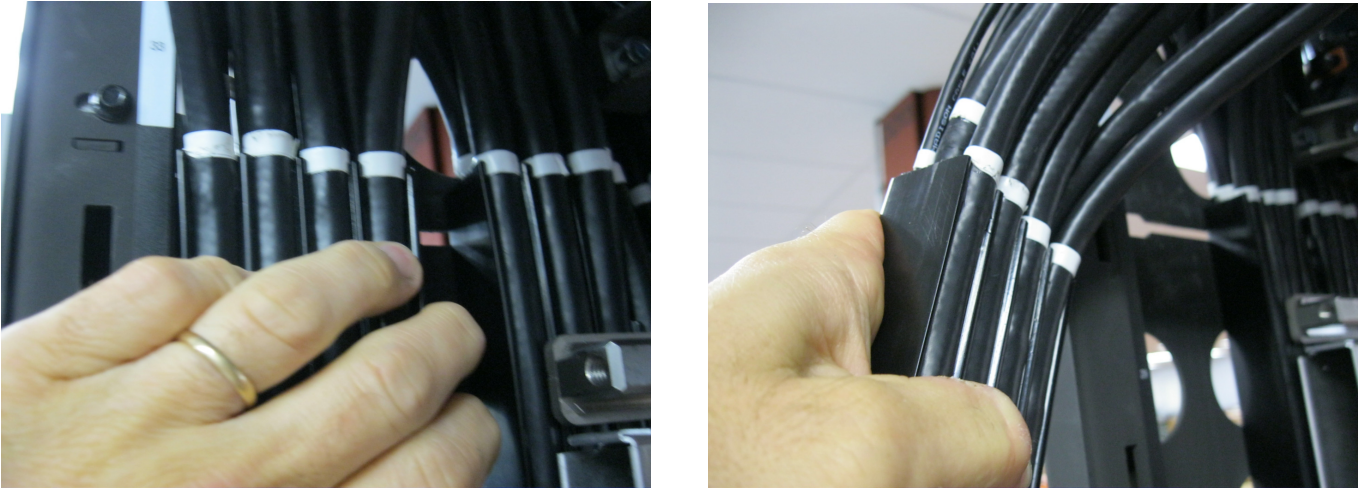

Figure 15 DCCA Power Cable Raceway Removal

STEP 16 Remove the target power cable from system. Remove the desired power cable out of the raceway (see Figure 16 below).

- a) Locate the BPD end of the desired power cable and unscrew/unplug the connector from the BPD using the same process that you used to remove the power cable from the DCCA end.

NOTE: DCCA Communication Cables and Velcro ties will need to be temporarily removed from the cable bundle to gain access to the desired cable allowing it to be removed.



Figure 16 DCCA Power Cable Removal

Power775 Distributed Converter and Control Assembly (DCCA) Power Cable Service Procedure

PN: 41U8492, EC N44172

Note that if removal of the long raceway is required for cables associated with drawer locations 5, 7, 9, and/or 11, the lower left BPE mounting bracket and standoff must be removed to allow the raceway to be slid forward. Using ratchet 6428140, extension 46K2707, and 5mm hex bit 74Y0986, loosen the captive screws and remove the BPE mounting bracket. Using 16mm socket 5497588, remove the mounting standoff from the rack. The long raceway and cables can now be slid forward. (see photo in Figure 17)

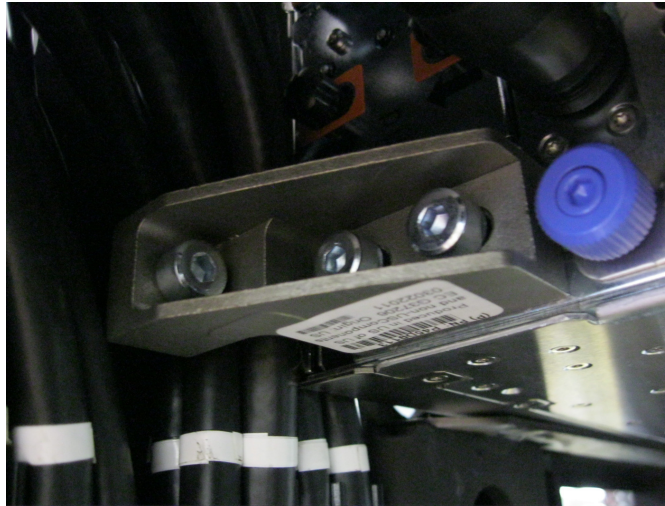

Figure 17 BPE Mounting Bracket Removal

3.3 Re-installation of Mechanicals and Installation of new DCCA Power Cable <= SSR TASK

STEP 17 On the new cable, verify that the plug location labels on the backshell are located on the appropriate ends of the cable (DCCA or BPD end). Align the white stripe on the cable jacket with the top surface of the raceway and stripes on adjacent cables. The DCCA Power Cable is triangular in profile and the flat surface must face downward in the raceway. Starting from the white stripe, firmly press the cable into the raceway finger working downward until the cable is fully inserted. All cables in the raceway finger must be nested in their proper position including the smaller communications cables at the base with no twists or kinks (refer to Figure 2 for proper cable placement within the raceway).

STEP 18 Once the new cable has been inserted into the appropriate raceway slot, re-place raceways into their original positions. Re-place BPE mounting bracket and standoff if necessary.

STEP 19 Secure UPIC raceway bracket retention screw using ¼” drive ratchet and 7mm socket (see photo in Figure 13).

STEP 20 Plug cable backshell into the appropriate receptacle on the CEC DCCA (or Disk Enclosure DCCA). Secure backshell jack screws using 2mm hex driver 74Y0983. Cable path and bend radius must be similar to adjacent cables and must be secured with Velcro strap similar to adjacent cables.

Power775 Distributed Converter and Control Assembly (DCCA) Power Cable Service
Procedure
PN: 41U8492, EC N44172

STEP 21 Plug cable backshell into the appropriate receptacle on the BPD. Secure backshell jack screws using 2mm hex driver 74Y0983. The cable is to be bundled with existing cables in front of the BPD using Velcro straps as needed.

STEP 22 Move UEPO down to the standard location using 4mm hex driver 41V1059.

STEP 23 Install cover latch using hex driver 41V1059. Check to ensure the front cover closes properly and adjust cable paths if required.

STEP 24 Close HMC Serviceable Event for Power Cable being serviced.

STEP 25 After all cable management tasks have been completed activate the BPD port that provides power to this DCCA Power Cable. You should use BPC ASM from the A side BPA activating a cable on the left side of the frame, but use BPC ASM from the B side BPA if activating a cable on the right side of the frame. Use BPC ASM to activate the BPD port using the following command format(note this similar to STEP 10, but starts with '11' instead of '10'):

```
bpccmd -c 11ee0000ff<FF><TT>
```

If you did not save/record the information from STEP 10 when deactivating the power cable, the information is presented again below. If you did not close your BPC ASM session, you should be able to retrieve your last command and simply change the last BPC ASM command to match the activation command presented above.

FF is the fru id, it is 81 for the A side BPA(lower BPA) and C1 for B side BPA(upper BPA)

For CEC Drawers:

T1 DCCA port Power Cables are on the A side BPA - 81

T4 DCCA port Power Cables are on the B side BPA - C1

For Disk Enclosures Drawers, see Figure 9:

T1 DCCA port Power Cables are on the A side BPA - 81

T4 DCCA port Power Cables are on the B side BPA - C1

All T1 DCCA port Power Cables route to the left of the frame to the A side BPA.

All T4 DCCA port Power Cables route to the right of the frame to the B side BPA.

TT is the BPD Static Circuit Breaker(SCB) connector id: 01 to 1A.

Use Figure 8 to determine the correct TT value.

For CEC Drawer DCCAs you must determine the Cage ID(Node ID) from Figure 7 based on which CEC Drawer is being serviced. Then determine the TT value by identifying the SCB connector ID from Figure 8. Viewing Figure 8 complete the following:

Power775 Distributed Converter and Control Assembly (DCCA) Power Cable Service Procedure

PN: 41U8492, EC N44172

- D. Find region of chart corresponding to the DCCA you are servicing, remember that the top unit is DCCA1 and the bottom unit is DCCA2. Use the column labeled as “Node DCA”.
- E. Then find the row of the chart(within the DCCA1 or DCCA2 region) that corresponds to the CEC Drawer Cage ID in the column labeled as “Node ID”
- F. Using the row identified in above in “B”, identify the appropriate TT value listed in the SCB column.

Example:

CEC Drawer DCCA1, Cage ID 03 would be the top row and the TT value for the SCB is “01”

For Disk Enclosure DCCAs you must determine the Cage ID(Disk Enclosure ID) from Figure 6 based on which DE is being serviced. Then determine the TT value by identifying the SCB connector ID from Figure 8. Viewing Figure 8 complete the following:

- D. Find region of chart corresponding to the DCCA you are servicing, remember that the left unit is DCCA1 and the right unit is DCCA2. Use the column labeled as “Disk Enclosure DCA”.
- E. Then find the row of the chart(within the DCCA1 or DCCA2 region) that corresponds to the DE Cage ID in the column labeled as “Disk Enclosure ID”
- F. Using the row identified in above in “B”, identify the appropriate TT value listed in the SCB column.

Example:

DE DCCA2, Cage ID 0F would be the bottom row and the TT value for the SCB is “1A”

A successful return code is: ‘00EE00’. If you do not receive a successful return code, contact next level of support.

Example:

```
bpcmd -c 11ee0000ff8101
```

Executes the power activation command for the power cable attached to the bottom CEC Drawer (in U.5) for the T1(left DCCA port - 81) in the top DCCA(DCCA1 - 01)

Power775 Distributed Converter and Control Assembly (DCCA) Power Cable Service Procedure

PN: 41U8492, EC N44172

STEP 26 Verify the green LED for the DCCA Power Cable that indicates 350VDC present is now turned on. This step will verify that 350VDC has been properly activated to the DCCA Power Cable and that the power cable is functioning properly. **NOTE:** If the green LED indicating 350VDC present does not turn on. Deactivate the BPD port as defined in STEP 10 and then reactivate the BPD port back on as defined in STEP 25.

STEP 27 Are you are servicing a cable on a CEC Drawer?

If Yes, then perform STEP 28 to STEP 29, then skip to STEP 31

If No(performing cable service on a DE), then skip to STEP 30.

STEP 28 Turn off the Identification LEDs for the UEPO switch, CEC Drawer and DCCA. Return to the window titled **Identify LED, Select Location**, and *click* the **Deactivate LED** button.

STEP 29 *Click* the **Cancel** buttons to close the **Identify LED** windows. Skip to STEP 31.

STEP 30 Turn off the Identification LEDs for the UEPO switch, DE and DCCA, use the BPC FSP ASM to issue the following command, using the procedure “Appendix: Power775 BPC FSP Command Line Procedure” (included in this PDF). This is the same command as in STEP 7 except 00 instead of 02 at the end of the command:

```
bpccmd -c 27110000<CageID><FF>00
```

Where CageID is the 2 character Hex value for the Disk Enclosure(Figure 6).

FF is the fru id, it is 90 for DCCA1 and 91 for DCCA2

For Disk Enclosures:

DCCA1 is the left DCCA - 90

DCCA2 is the right DCCA – 91

A successful return code is: ‘001100’. If you do not receive a successful return code, contact next level of support.

Example:

```
bpccmd -c 271100000f9000
```

Executes the command on DCCA1(left DCCA) of the DE installed in Cage 0f

STEP 31 Log out of BPC FSP ASM.

STEP 32 Close the front door. Procedure is now complete.

4 END OF POWER775 DISTRIBUTED CONVERTER AND CONTROL ASSEMBLY POWER CABLE SERVICE PROCEDURE

5 APPENDIX A: POWER775 BPC FSP COMMAND LINE PROCEDURE

5.1 Procedure to Access the BPC FSP Command Line

1. The HMC can be accessed via the keyboard/display that resides in the network management rack.
2. Login to the HMC if not done already.
3. In the HMC navigation pane, expand 'Systems Management' + sign and then click 'Frames':

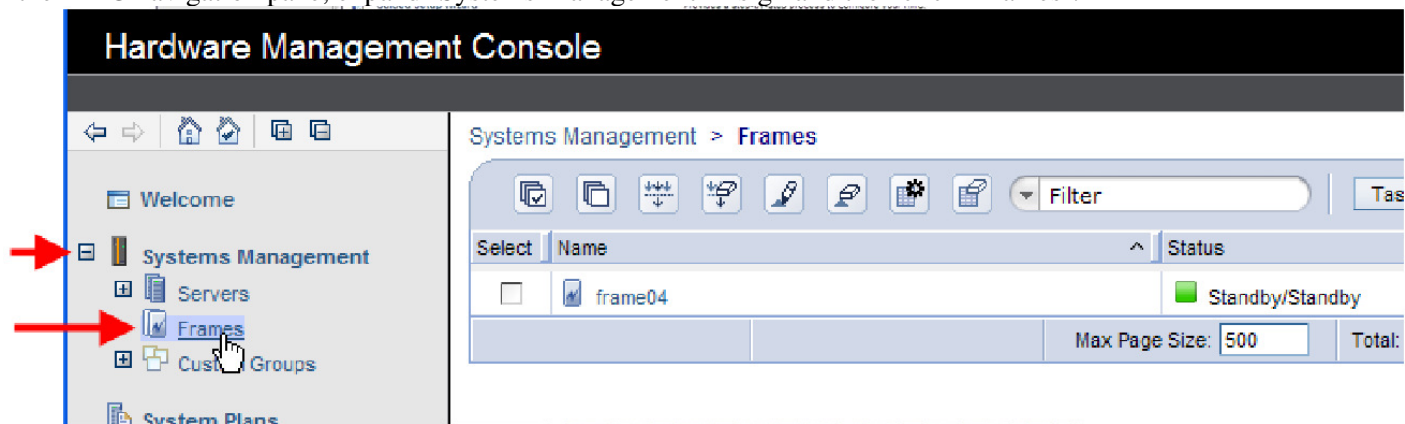

4. From the Tasks Menu right-arrow pull-down menu, click **Operations** → **Launch Frame Advanced Systems Management (ASM)**

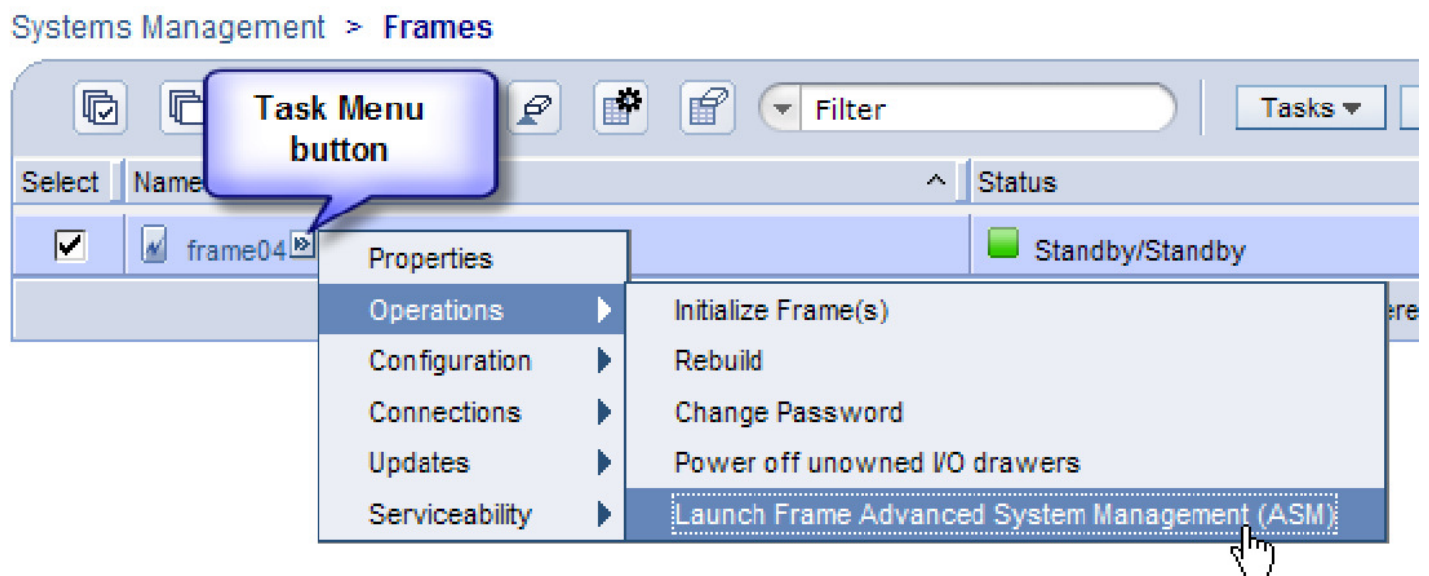

Power775 Distributed Converter and Control Assembly (DCCA) Power Cable Service Procedure

PN: 41U8492, EC N44172

5. From the Launch ASM Interface window, select **SIDE_A** for the 'Frame IP Address' then click the **OK** button.

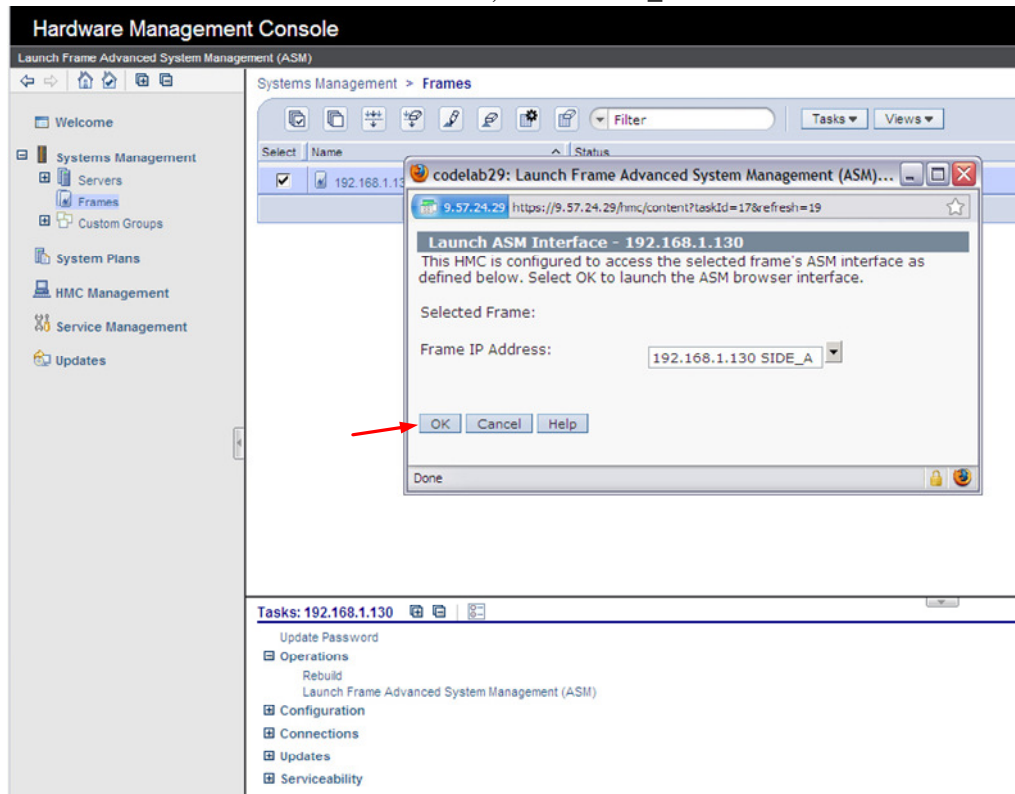

6. The ASM login window is presented. Acquire the necessary User ID and Password.

“celogin” requires Daily PW from the IBM Support Center.

“celogin1” might be has enabled by the customer. If so, obtain the password from the customer.

1. Enter User ID
2. Enter Password
3. Click **Log in** button

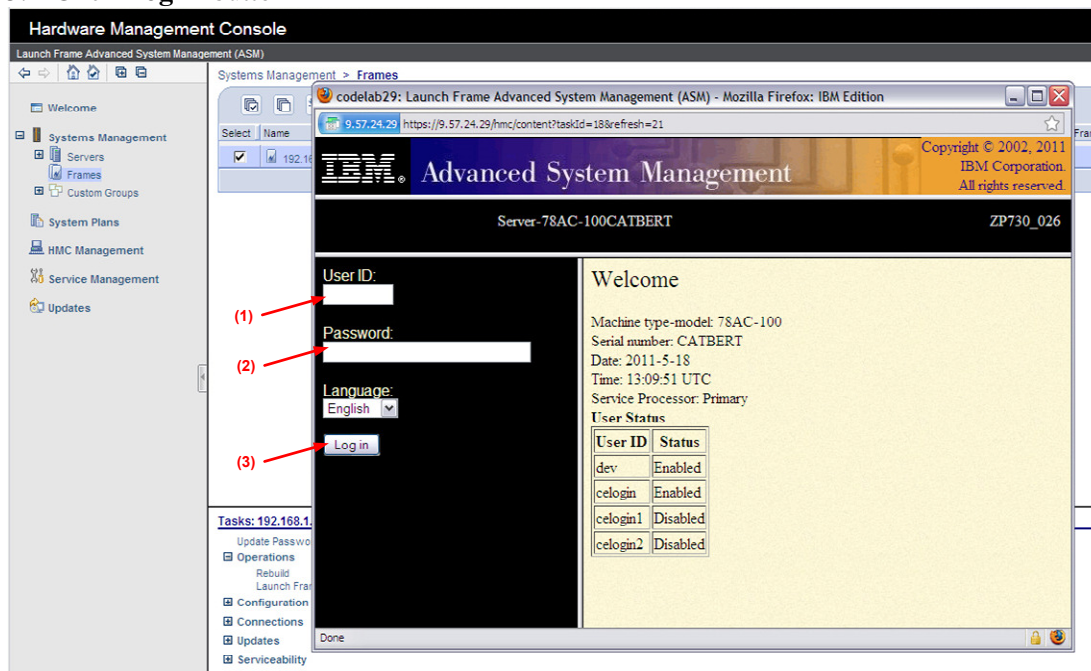

Power775 Distributed Converter and Control Assembly (DCCA) Power Cable Service
Procedure
PN: 41U8492, EC N44172

7. Expand 'System Service Aids' + sign and Select 'Service Processor Command Line'.

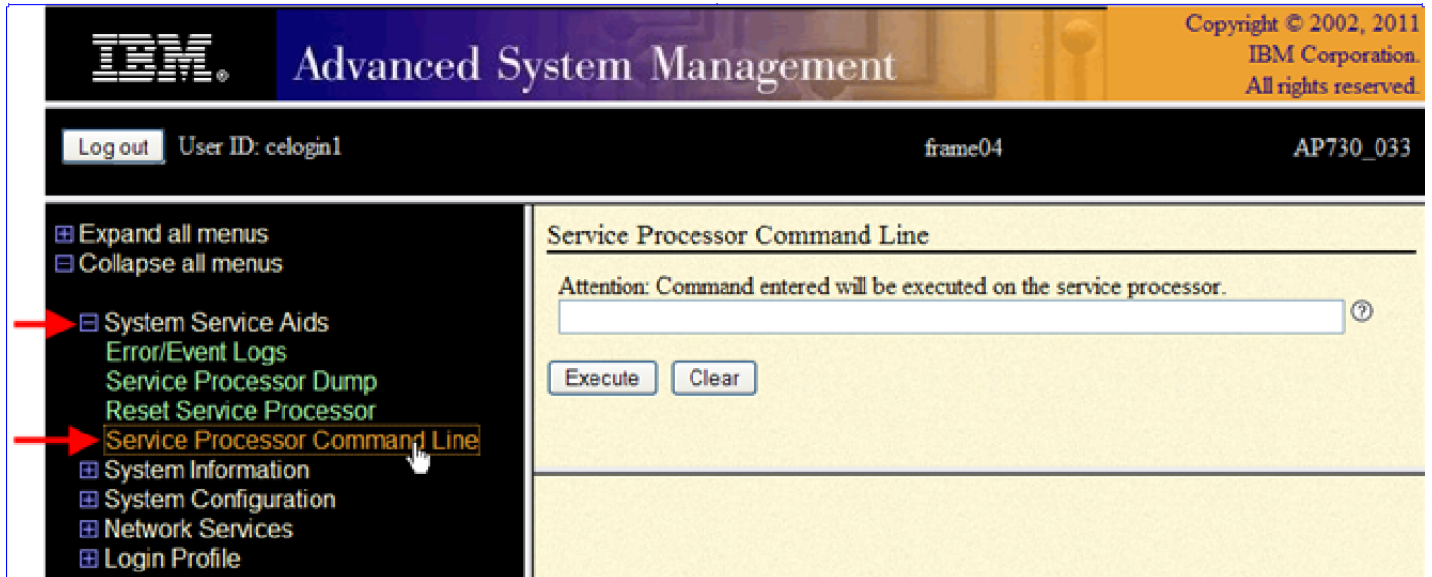

8. The ASM BPC FSP Command line will be presented. Enter the commands defined in the paper service procedures at this command line and press the Enter key (or click the **Execute** button).
9. Return to the step of the paper service procedure that directed you to this Appendix.

5.2 End of Appendix A: Power775 BPC FSP Command Line Procedure