

Power775 CEC Fill and Drain Tool (FDT) Procedures

Last Modified 3/6/2012 3:18 PM

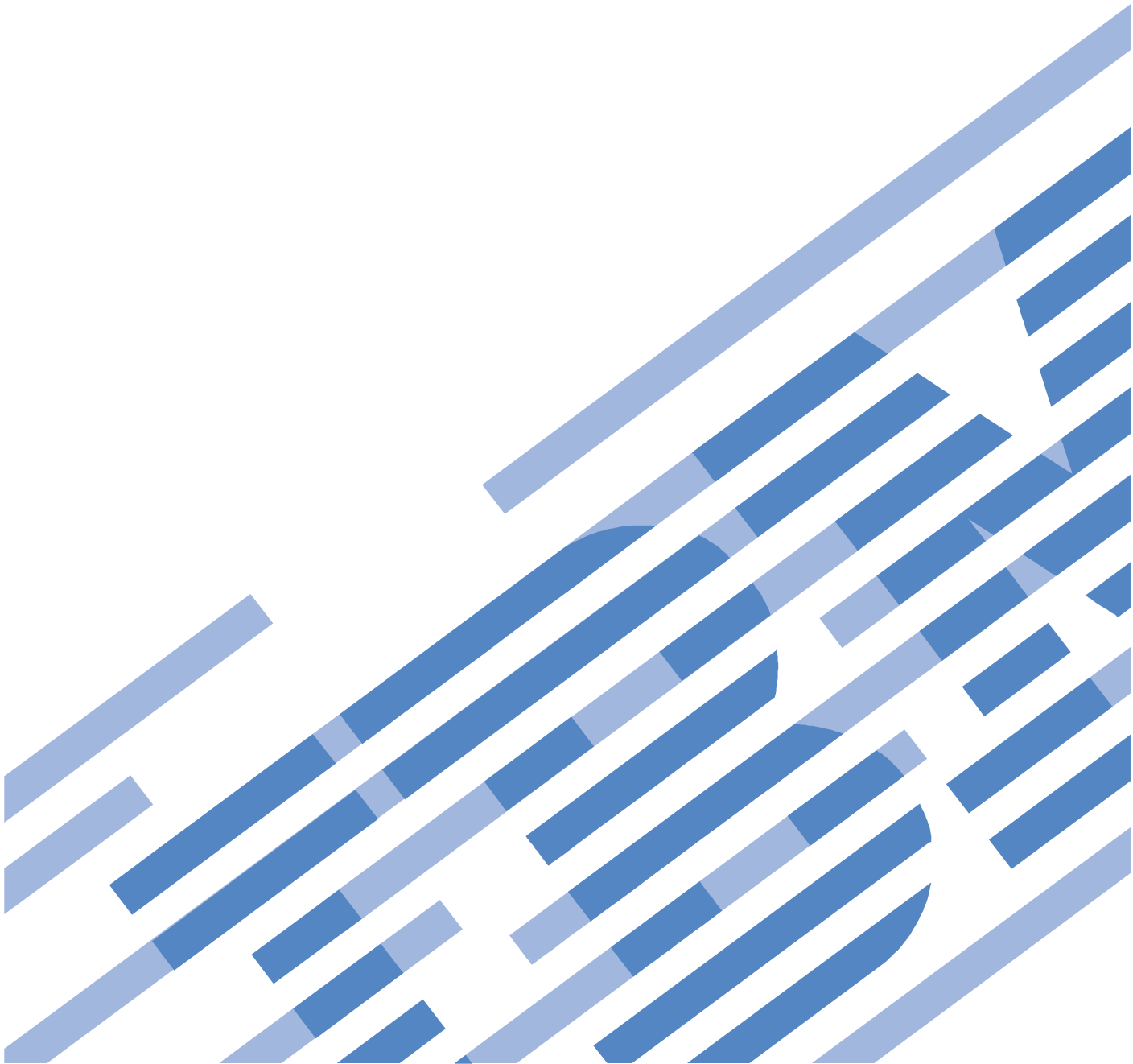

CONTENTS

1	GENERAL	4
1.1	RELEASE / REVISION HISTORY	4
1.2	WHERE TO FIND THIS DOCUMENT, AND CONTENTS OF THE PARENT PDF	4
1.3	REQUIRED DOCUMENTS	4
1.4	ABBREVIATIONS	5
2	POWER775 CEC DRAIN PROCEDURE	6
2.1	SAFETY NOTICES	6
2.2	BACKGROUND:	8
2.3	PROCEDURE:	8
2.4	END OF POWER775 CEC DRAIN PROCEDURE	20
3	POWER775 CEC FILL PROCEDURE	21
3.1	SAFETY NOTICES	21
3.2	BACKGROUND:	23
3.3	PROCEDURE:	23
3.4	END OF POWER775 CEC FILL PROCEDURE	37
4	POWER775 CEC PRESSURE TEST PROCEDURE	38
4.1	SAFETY NOTICES	38
4.2	BACKGROUND:	40
4.3	PROCEDURE:	40
4.4	END OF POWER775 CEC PRESSURE TEST PROCEDURE	52
5	POWER775 FILL AND DRAIN TOOL (FDT) TANK DRAIN PROCEDURE	53
5.1	SAFETY NOTICES	53
5.2	BACKGROUND:	55
5.3	PROCEDURE:	55
5.4	END OF POWER775 FDT TANK DRAIN PROCEDURE	68
6	POWER775 FILL AND DRAIN TOOL (FDT) TANK FILL PROCEDURE	69
6.1	SAFETY NOTICES	69
6.2	BACKGROUND:	71
6.3	PROCEDURE:	71
6.4	END OF POWER775 FDT TANK FILL PROCEDURE	83
7	POWER775 FILL AND DRAIN TOOL (FDT) PRESSURE TEST CALIBRATION PROCEDURE	84
7.1	SAFETY NOTICES	84
7.2	BACKGROUND:	86
7.3	PROCEDURE:	86
7.4	END OF POWER775 FDT PRESSURE TEST CALIBRATION PROCEDURE	97
8	APPENDIX A: IBM POWER775 FDT VOLUME TABLES	99
8.1	IBM POWER 775 COMPONENT WATER VOLUMES	99
8.2	IBM POWER 775 SYSTEM WATER VOLUMES	99
8.3	IBM POWER 775 SYSTEM WATER CONTAINERS PER FRAME	100
8.4	END OF APPENDIX A: POWER775 FDT VOLUME TABLES	100

Table List

Table 1 Release / Revision History	4
Table 2 Required Documents.....	4
Table 3 Abbreviations	5
Table 4 IBM Power 775 Component Water Volumes	99
Table 5 IBM Power 775 System Water Volume (Liters).....	99
Table 6 IBM Power 775 System Water Volume (Gallons).....	99
Table 7 IBM Power 775 Required Number of System Water Containers per Frame	100

1 GENERAL

1.1 Release / Revision History

Document Name	Date	PDF name	Description
Power775 CEC Fill and Drain Tool (FDT) Procedures	3/6/2012	"p775_cec_fdt.pdf"	Initial Release

Table 1 Release / Revision History

1.2 Where to find this document, and contents of the parent PDF

The current "Power775 CEC Fill and Drain Tool (FDT) Procedures" document is "p775_bpd_fdt.pdf" which is to be downloaded from:

InfoCenter Website: <http://publib.boulder.ibm.com/infocenter/powersys/v3r1m5/topic/p7ee2/p7ee2kickoff.htm>

Click "PDF files for the IBM Power 775 (9125-F2C) removing and replacing parts"

Under "Fill and Drain Tool (FDT) procedures to support R&V FRUs", click "CEC" to download PDF "p775_cec_fdt.pdf"

This is the only valid source for the latest "Power775 CEC Fill and Drain Tool (FDT) Procedures" document.

1.3 Required Documents

Document	Doc Number	Location
Safety Notices http://publib.boulder.ibm.com/infocenter/powersys/v3r1m5/topic/p7hdx/G229-9054.pdf	G229-9054	InfoCenter

Table 2 Required Documents

1.4 Abbreviations

Abbreviation	Definition	Details
BPA	Bulk Power Assembly	
BPD	Bulk Power Distributor	
CEC	Central Electronic Complex	Also referred to as the “node”.
DCCA	Distributed Conversion and Control Assembly	The power supplies for the CEC and DE are called the CEC DCCA and DE DCCA respectively.
DE	Disk Enclosure	
FRU	Field Replaceable Unit	
HPIC	High Power Interface Cable	DCCA power cable
LED	Light Emitting Diode	
LIC	Licensed Internal Code	
SAS	Serial Attached SCSI	Protocol used for direct attached storage
SSR	Systems Services Representative	IBM Service personnel
UEPO	Unit Emergency Power Off	
UPIC	Universal Power Interface Cable	Cable used for power and communication to the Power 775 Fill and Drain Tool (FDT).

Table 3 Abbreviations

2 POWER775 CEC DRAIN PROCEDURE

2.1 Safety Notices

Read “Safety Notices“ available from InfoCenter:

<http://publib.boulder.ibm.com/infocenter/powersys/v3r1m5/topic/p7hdx/G229-9054.pdf>

The following cautions apply to all Power775 service procedures:

CAUTION:

Energy hazard present and Shorting might result in system outage and possible physical injury. Remove all metallic jewelry before servicing. (C001)

CAUTION:

The doors and covers to the product are to be closed at all times except for service by trained service personnel. All covers must be replaced and doors locked at the conclusion of the service operation. (C013)

CAUTION:

Servicing of this product or unit is to be performed by trained service personnel only. (C032)

The following notices specifically pertain to this Power775 service procedure.

CAUTION: The water-based coolant solution may contain an additive intended to inhibit corrosion (or provide other functions). The solution may cause irritation to the skin or eyes. Avoid direct contact with the solution. Employ appropriate Personal Protective Equipment when performing operations involving the coolant or which may potentially expose you to the coolant. Refer to the MSDS for more information. (C037)

CAUTION: This unit must not be left running unattended, service personnel should always be overseeing the process. (C038)



DANGER: Hazardous voltage present. Voltages present constitute a shock hazard, which can cause severe injury or death. (L004)



CAUTION: Protective eyewear is needed for the procedure. (L011)



DANGER: Heavy equipment—personal injury or equipment damage might result if mishandled. (L013)



CAUTION: Chemical resistant gloves are needed for this procedure. (L014)

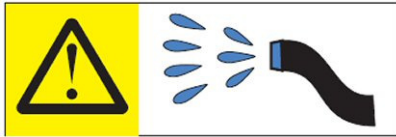

DANGER: Risk of electric shock due to water or a water solution which is present in this product. Avoid working on or near energized equipment with wet hands or when spilled water is present. (L016)

2.2 Background:

This document contains the procedure for draining the water out of a Central Electronics Complex (CEC) on an **IBM Power 775** system using an **IBM Power 775** Fill and Drain Tool (FDT).

Due to high packaging density and heat load, the **IBM Power 775** CEC is water cooled, and contains internal plumbing to route cooling water towards and carry heat away from critical power sub-components.

In the event that a CEC is scheduled for removal from a **IBM Power 775** system, the CEC will need to be drained of water prior to removal. All water cooled field replaceable units (FRU's), including CEC's, must be shipped empty from the client location to IBM to eliminate the risk of damage from water leakage or freezing during transport. Draining a CEC with the FDT purges the water from the component with pressurized air, and returns the water to the internal reservoir within the FDT for reuse.

After a CEC drain procedure has been completed, the CEC water plumbing may be under a slight positive pressure due to the pressurized air that was flowing through the component. This is expected, and the pressure will be no greater than 5 psi.

Reference Information:

IBM Power 775 FDT P/N:	45D6928
Hose assemblies/adapters required:	HA1 (45D8561) HA2 (45D8562)

Approximate CEC water volume: 1.7 L

Expected time to fully drain CEC with FDT: 60 seconds

NOTE: *Some steps in this procedure may be redundant due to other service operations being completed prior to this procedure. If a step has already been completed, verify that the step has been completed properly and proceed to the next step.*

NOTE: *The location of the component for the drain procedure is not important. The drain procedure can be completed with the component on a cart, on the lift tool, or mechanically installed in the frame.*

2.3 Procedure:

NOTE: If you already have the FDT powered on, proceed to **Step 14**. Otherwise, start procedure at **Step 1**.

Power775 CEC Fill and Drain Tool (FDT) Procedures
---- CEC Drain Procedure ----

1. Identify the **Power 775** frame that requires service.

Verify that the system UEPO is set to **ON**, and the managing consoles (HMC and XCat) are powered on and communicating with the frame.

2. Open front and rear doors of the **Power 775** frame that requires service.

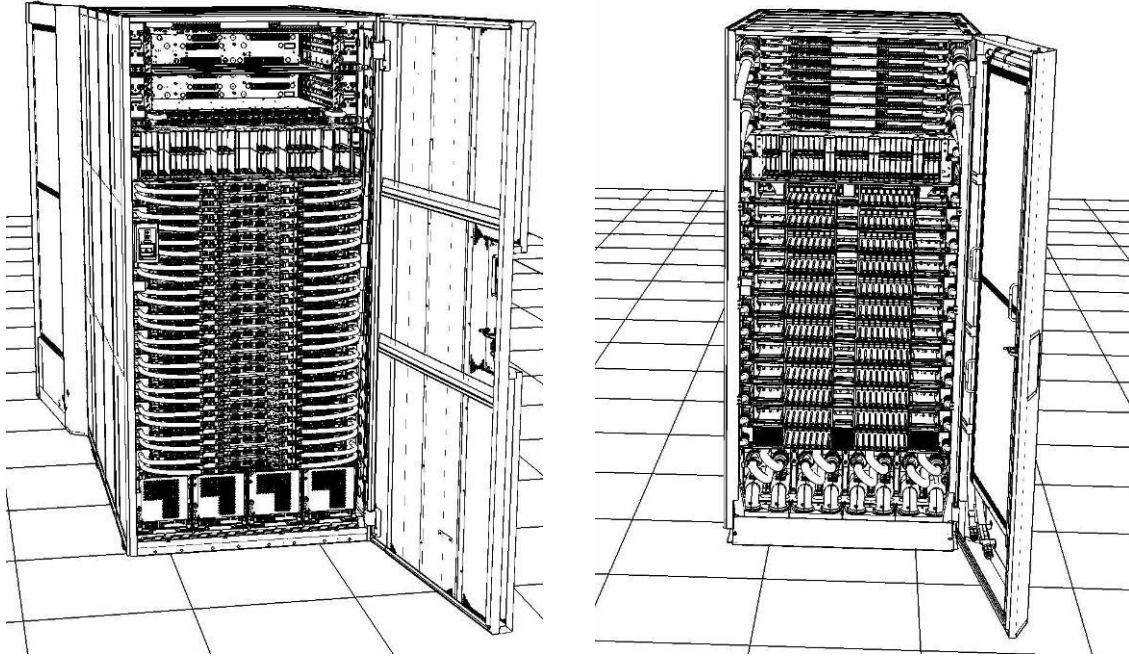

3. Bring the FDT to the front side of the **Power 775** frame that requires service.
4. Locate the panel of the FDT that contains the Universal Power and Information Cable (UPIC), as well as the **TS**, **TR**, and **TEST** water connections.

This side of the tool should be facing the front of the frame.

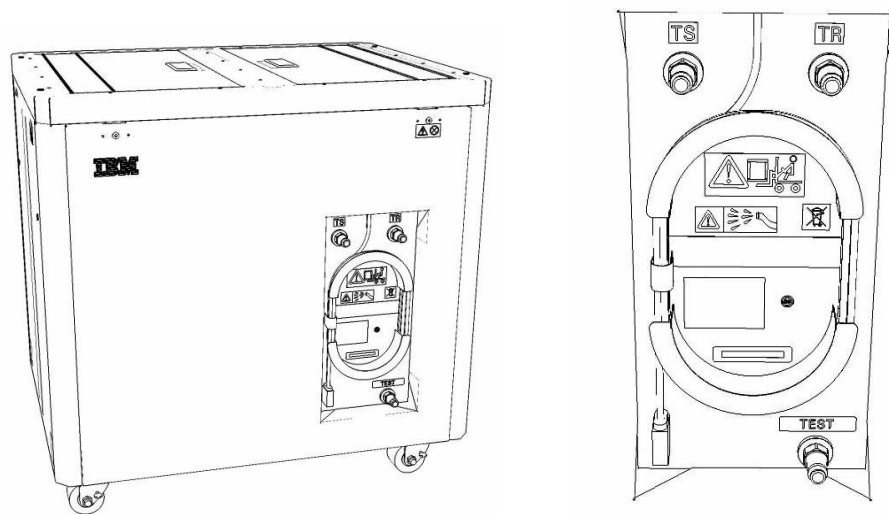

5. Unwrap the FDT UPIC cable from the storage loop on the FDT.

6. Select BPC port for FDT

- If the lower BPA is not targeted for service, and is functional:
Plug the FDT UPIC cable into **port T10 of the lower BPC.**
- If the lower BPA is targeted for service, or is not functional:
Plug the FDT UPIC cable into **port T10 of the upper BPC.**

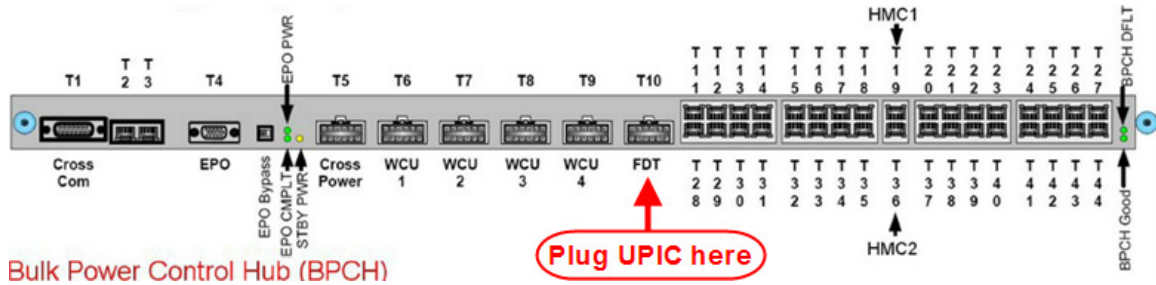

7. Login to the HMC with the User ID `hscroot`.

Use the HMC that is connected to the BPA where the FDT is plugged.

8. From the HMC left Navigation menu, expand **Systems Management** then select **Frames**.

Verify frame serial number for the frame to be serviced.

9. In the **Frames** view on the HMC, place a checkmark in the **Select** column for the frame to be serviced.

10. Verify that the frame **Status** is **Rack Standby/Rack Standby** or **Standby/Standby**.

- If frame **Status** reads **Rack Standby/Rack Standby** or **Standby/Standby** – OK.

Continue to next step.

- If frame **Status** does not read **Rack Standby/Rack Standby** or **Standby/Standby** – action required. Contact next level of support.

11. From the **Task** menu on the HMC, *select* **Serviceability** > **Hardware** > **Fill and Drain Tool Tasks** > **Fill and Drain Command Interface**

Power775 CEC Fill and Drain Tool (FDT) Procedures
 ---- CEC Drain Procedure ----

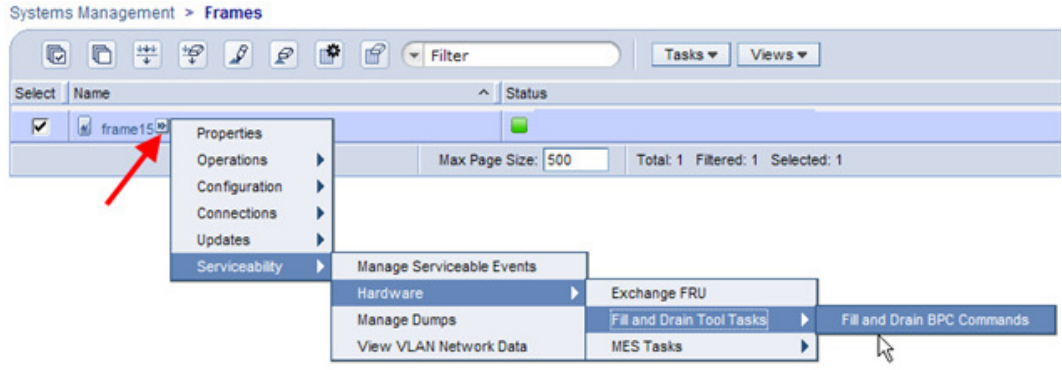

Fill and Drain Tool Command Interface will display. See below for a sample image of the interface (FDT deactivated).

Fill and Drain Tool (FDT) Command Interface - Server-78AC-100BC50029

The table below shows the FDT Port locations that can communicate with the Fill and Drain Tool. Select the port to which the Fill and Drain Tool is connected. Use the buttons to drive commands to the Fill and Drain Tool connected to a port.

FDT Port Locations:

Select	Location Code	Description
<input type="radio"/>	78AC-100*BC50029-P7-C1	Lower BPC Port T10
<input type="radio"/>	78AC-100*BC50029-P8-C1	Upper BPC Port T10

Activate FDT Deactivate FDT
Get FDT Status Decode Error Status
Fill FDT Drain FDT
Start Water Pump Reset FDT Start Air Pump
Pressure Test Calibration Component Pressure Test

Launch WCU Commands WCU Tank Air Purge
Exit Help

12. Select the BPC port that the FDT was plugged into in **Step 6** from the **FDT Port Locations:** list.

13. *Click* the **Activate FDT** button.

- If the Activate FDT command is successful – OK. **Wait 30 seconds and continue to next step.**
- If the **Activate FDT** command fails – action required.

Click the **Deactivate FDT** button.

Wait 2 minutes and repeat **Step 13**. If the **Activate** command fails again, contact next level of support.

14. *Click* the **Get FDT Status** button.

- If the **Get FDT Status** command is successful – OK.

See below for a sample status (does not reflect expected state)

- If the **Get FDT Status** command fails – action required.

Repeat **Step 14**. If the **Get FDT Status** command fails again, contact next level of support.

Fill and Drain Tool (FDT) Command Interface - Server-78AC-100BC50029

The table below shows the FDT Port locations that can communicate with the Fill and Drain Tool. Select the port to which the Fill and Drain Tool is connected. Use the buttons to drive commands to the Fill and Drain Tool connected to a port.

FDT Port Locations:

Select	Location Code	Description
<input checked="" type="radio"/>	78AC-100*BC50029-P7-C1	Lower BPC Port T10
<input type="radio"/>	78AC-100*BC50029-P8-C1	Upper BPC Port T10

FDT Power/Comm: GOOD
 Frame Attached: IBM Power7 775
 MDA-FD RL: 45D
 Error Status: WARNING
 Tank Level: Full
 Air Pump: Off
 Water Pump: DISABLED
 Tool Mode: Ready
 Pressure Test Calibration: Incomplete
 Component Pressure Test: Incomplete

Sample FDT Status

15. Review the FDT status screen and ensure that the following status items are OK:

- | Status Item | State | Action |
|------------------------|-----------------------------------|--|
| • Tool Mode: | Ready | – OK. Check next Status item. |
| • Error Status: | NONE | – OK. Check next Status item. |
| | WARNING | – <i>click</i> the Decode Error Status button, record the information returned and check Tank Level. |
| | CRITICAL | – <i>click</i> the Decode Error Status button, record the information returned and contact next level of support. |
| • Tank Level: | Lower Half or Empty | – OK. Continue to next step. |

Full or Upper Half – action required.

Exit this procedure and complete a **Fill and Drain Tool (FDT) Tank Drain Procedure**.

Once FDT tank level is **Lower Half** or **Empty**, return to this step and continue with procedure.

16. Verify all CEC DCCA water hoses are connected to the CEC being serviced.

CEC DCCA must be installed in CEC during drain procedure.

17. Verify that the CEC being serviced is powered-off:

CEC GOOD LED should be off.

CEC should have been powered-off during mechanical removal procedure.

18. Before proceeding, read required safety information:

CAUTION: The water-based coolant solution may contain an additive intended to inhibit corrosion (or provide other functions). The solution may cause irritation to the skin or eyes. Avoid direct contact with the solution. Employ appropriate Personal Protective Equipment when performing operations involving the coolant or which may potentially expose you to the coolant. Refer to the MSDS for more information. (C037)



CAUTION: Protective eyewear is needed for the procedure. (L011)



CAUTION: Chemical resistant gloves are needed for this procedure. (L014)

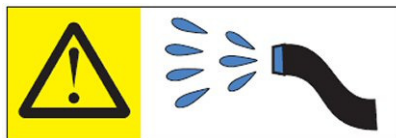

DANGER: Risk of electric shock due to water or a water solution which is present in this product. Avoid working on or near energized equipment with wet hands or when spilled water is present. (L016)

19. Verify CEC position for drain procedure.

- If the CEC is not installed in the system – OK. Continue to next step.
- If the CEC is installed in the system – action required.

Disconnect the left **and** right main water connections from the CEC to be drained.

NOTE: Do not disconnect water connections on a CEC that has not been powered off. Loss of water flow will result in CEC overheating and failure.

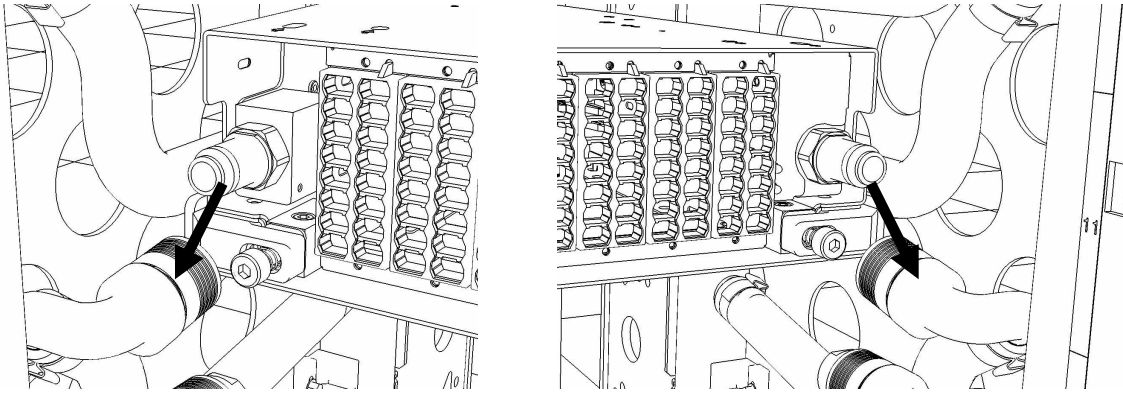

20. Remove hose assembly **HA1** from the upper tool storage compartment.

Connect either end of hose assembly **HA1** to the **TS** connection on the front panel of the FDT.

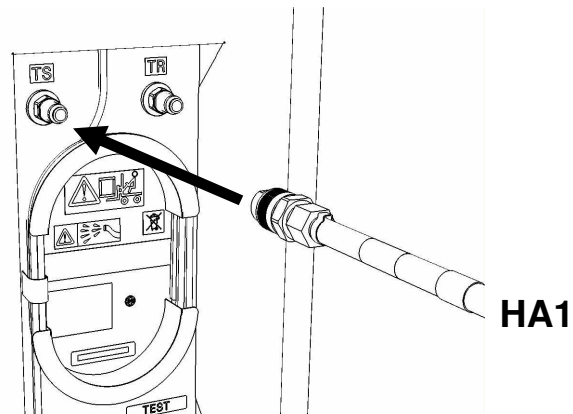

21. Remove hose assembly **HA2** from the upper tool storage compartment.

Connect end *without sight glass* to the **TR** connection on the FDT.

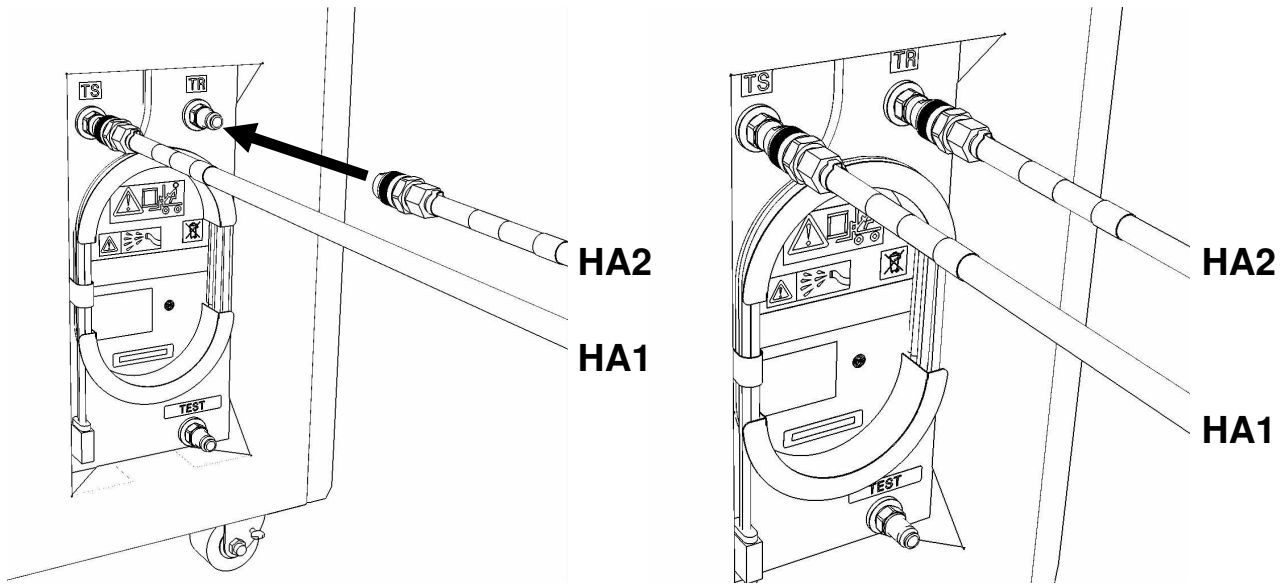

22. Verify CEC position for drain procedure.

- If the CEC is not installed system – OK. Continue to next step.
- If the CEC is installed in the system – action required.

Pass the unattached ends of **HA1** and **HA2** to the rear of the frame.

NOTE: Hose assemblies **HA1** and **HA2** can be passed **around** the frame or **over** the frame, depending on frame position. These hoses are long enough to complete all FDT service actions on the rear of the frame.

23. Connect **HA1** hose assembly to the left side CEC water connection.

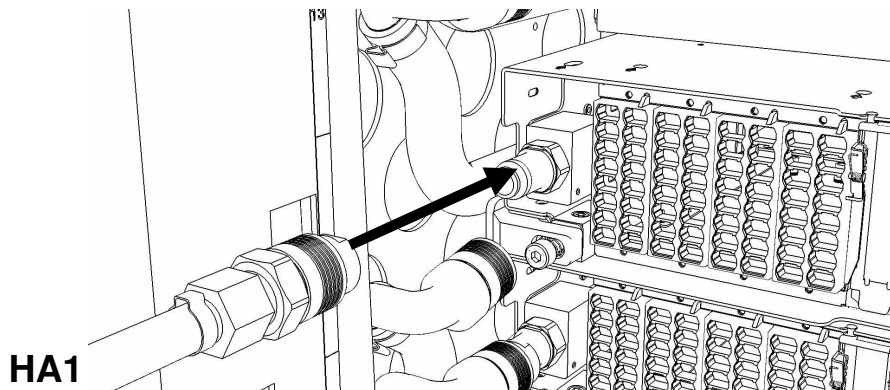

24. Connect **HA2** hose assembly to the right side CEC water connection.

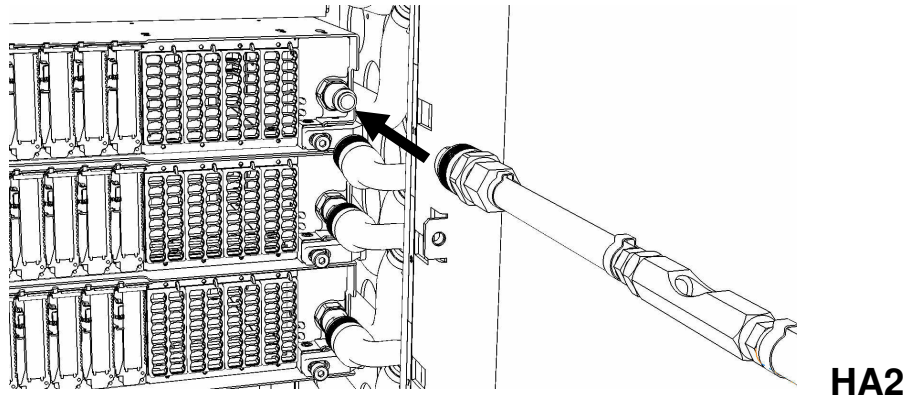

25. Ensure all hose connections are made properly and securely.
Verify hoses are connected as outlined in the schematic below.

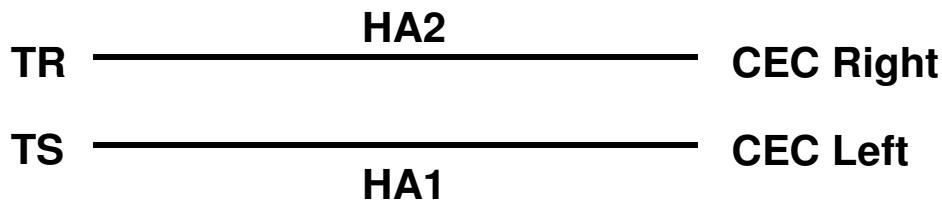

26. On the FDT panel, *click* the **Start Air Pump** button.

The **Get FDT Status** button may be *clicked* to examine FDT status.

NOTE: *The water pump will shut off after 1 minute, 40 seconds of run time.*

CAUTION: **This unit must not be left running unattended, service personnel should always be overseeing the process. (C038)**

27. Inspect the sight glass in hose assembly **HA2**.

The sight glass will provide verification that the component has been drained.

Expected sight glass behavior

- Sight glass will start out full of water while the component is being emptied.
- After some period of time, air will start passing through the sight glass in an air/water mixture.
- Eventually the sight glass will become full of air, with small water droplets/mist passing through the sight glass.

28. When the air pump has stopped running, review the following:

- **HA2** sight glass filled with air when pump stopped – OK.
Component empty. Proceed to next step.
- **HA2** sight glass filled with water when air pump stopped – action required.
Repeat **Step 20** through **Step 27**.

29. Click Get Status and ensure that the following status items are OK:

<u>Status Item</u>	<u>State</u>	<u>Action</u>
• Tool mode:	Ready – OK. Check next Status item. System/Component Drain Mode – air pump still running. Wait 30 seconds and repeat Step 29 .	
• Error Status:	NONE – OK. Check next Status item. WARNING – <i>click</i> the Decode Error Status button, record information returned and proceed to next step. CRITICAL – <i>click</i> the Decode Error Status button, record information returned and contact next level of support.	
• Tank Level:	Empty, Lower Half, Upper Half – OK. Proceed to next step. Full – action required. FDT tank drain required. Exit this procedure and complete a Fill and Drain Tool (FDT) Tank Drain Procedure . Once FDT tank level is Empty or Lower Half , return to Step 20 and continue with procedure.	

30. The CEC drain procedure has completed successfully.

The CEC has been emptied of water.

NOTE: *If a CEC Pressure Test Procedure will be completed following this test, disregard Step 31 - 32 and 34. These hose connections will be the same in the CEC pressure test procedure.*

31. Disconnect **HA1** assembly from the left side CEC water connection.

Power775 CEC Fill and Drain Tool (FDT) Procedures
---- CEC Drain Procedure ----

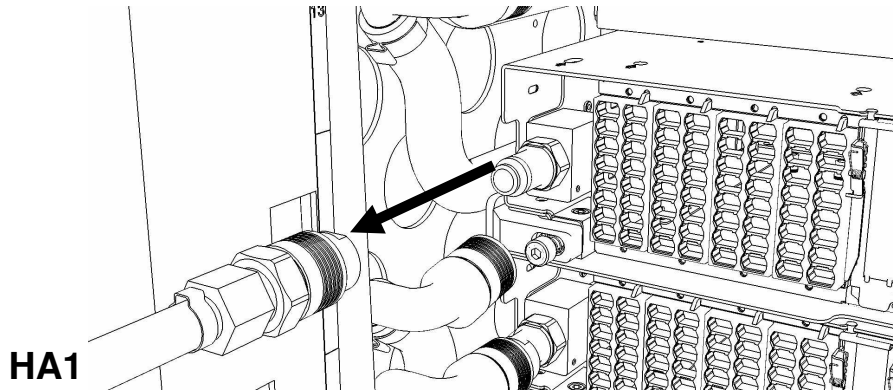

32. Disconnect **HA2** assembly from the right side CEC water connection.

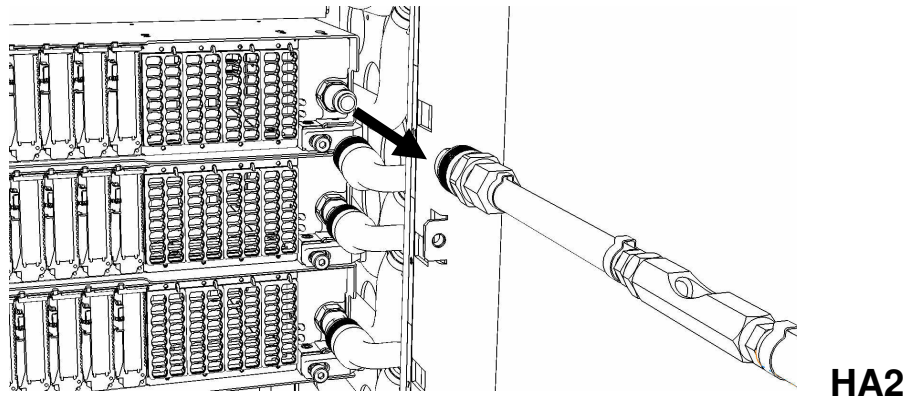

33. Disconnect the FDT end of **HA1** from **TS** on the FDT.

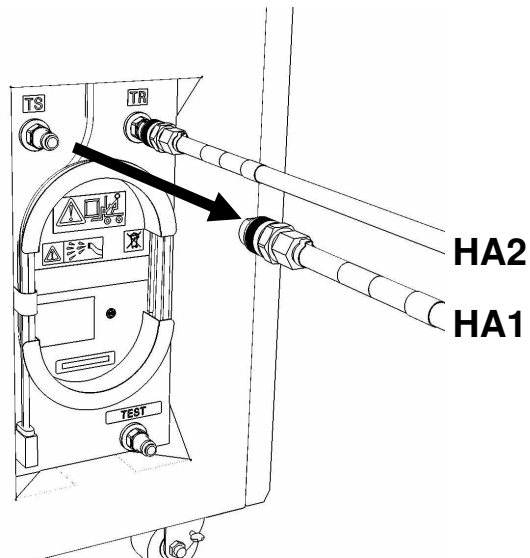

34. Disconnect the FDT end of **HA2** from **TR** on the FDT.

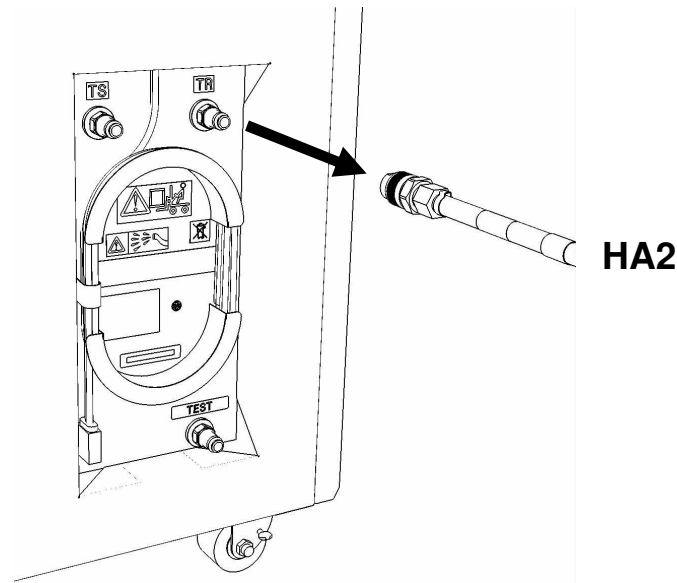

35. Place all hose assemblies and adapters in their appropriate locations within the FDT storage enclosure.

36. Determine whether the FDT will be used for another procedure:

- If the FDT will be used for another procedure, leave tool activated and go to that procedure now; skip the remaining steps of this procedure.
- If the FDT requires no further use - proceed to the next step.

37. Click the **Deactivate FDT** button.

- If the **Deactivate FDT** command is successful – OK. Proceed to next step.
- If the **Deactivate FDT** command fails– action required.

Repeat **Deactivate FDT**. If the **Deactivate FDT** command fails again, contact next level of support.

38. Disconnect FDT UPIC power cable from port T10 of BPC used.

Wrap the UPIC cable in appropriate cable storage location on FDT.

39. If this procedure was referenced from another procedure, return to parent procedure.

2.4 End of Power775 CEC Drain Procedure

3 POWER775 CEC FILL PROCEDURE

3.1 Safety Notices

Read “Safety Notices“ available from InfoCenter:

<http://publib.boulder.ibm.com/infocenter/powersys/v3r1m5/topic/p7hdx/G229-9054.pdf>

The following cautions apply to all Power775 service procedures:

CAUTION:

Energy hazard present and Shorting might result in system outage and possible physical injury. Remove all metallic jewelry before servicing. (C001)

CAUTION:

The doors and covers to the product are to be closed at all times except for service by trained service personnel. All covers must be replaced and doors locked at the conclusion of the service operation. (C013)

CAUTION:

Servicing of this product or unit is to be performed by trained service personnel only. (C032)

The following notices specifically pertain to this Power775 service procedure.

CAUTION: The water-based coolant solution may contain an additive intended to inhibit corrosion (or provide other functions). The solution may cause irritation to the skin or eyes. Avoid direct contact with the solution. Employ appropriate Personal Protective Equipment when performing operations involving the coolant or which may potentially expose you to the coolant. Refer to the MSDS for more information. (C037)

CAUTION: This unit must not be left running unattended, service personnel should always be overseeing the process. (C038)



DANGER: Hazardous voltage present. Voltages present constitute a shock hazard, which can cause severe injury or death. (L004)



CAUTION: Protective eyewear is needed for the procedure. (L011)



DANGER: Heavy equipment—personal injury or equipment damage might result if mishandled. (L013)



CAUTION: Chemical resistant gloves are needed for this procedure. (L014)

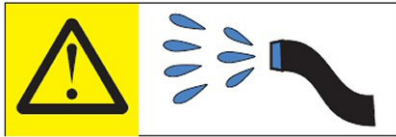

DANGER: Risk of electric shock due to water or a water solution which is present in this product. Avoid working on or near energized equipment with wet hands or when spilled water is present. (L016)

3.2 Background:

This document contains the procedure for filling a Central Electronics Complex (CEC) on an **IBM Power 775** system with treated water using an **IBM Power 775** Fill and Drain Tool (FDT). The successful execution of a **CEC Pressure Test** procedure is required for this procedure to be performed.

Due to high packaging density and heat load, the **IBM Power 775** CEC is water cooled, and contains internal plumbing to route cooling water towards and carry heat away from critical power sub-components.

In the event that a new CEC is to be added to a **IBM Power 775** system, the CEC must be tested for leaks and then filled with treated system water prior to installation into the frame. All water cooled field replaceable units (FRU's), including CEC's, are shipped empty to the client location from IBM to eliminate the risk of damage from water leakage.

Do not connect an empty CEC to the system as this would cause a large volume of air to be distributed throughout the system, resulting in increased component temperatures. Filling a CEC with the FDT prior to system connection prevents these conditions, and purges the air from the CEC through the use of a circulating water pump.

To ensure that the CEC plumbing is leak free prior to installation, the CEC must pass a CEC pressure test before the CEC can be filled. A CEC fill operation should not be performed unless the CEC pressure test has a passing result with a calibrated FDT.

Reference Information:

IBM Power 775 FDT P/N:	45D6928
Hose assemblies/adapters required:	HA1 (45D8561) HA2 (45D8562)

Approximate CEC water volume: 1.7 L
Expected time to fully fill CEC with FDT: 60 seconds

NOTE: *Some steps in this procedure may be redundant due to other service operations being completed prior to this procedure. If a step has already been completed, verify that the step has been completed properly and proceed to the next step.*

NOTE: *The location of the component for the fill procedure is not important. The fill procedure can be completed with the component on a cart, on the lift tool, or mechanically installed in the frame.*

3.3 Procedure:

NOTE: If you already have the FDT powered on, proceed to **Step 14**. Otherwise, start procedure at **Step 1**.

Power775 CEC Fill and Drain Tool (FDT) Procedures
---- CEC Fill Procedure ----

1. Identify the **Power 775** frame that requires service.

Verify that the system UEPO is set to **ON**, and the managing consoles (HMC and XCat) are powered on and communicating with the frame.

2. Open front and rear doors of the **Power 775** frame that requires service.

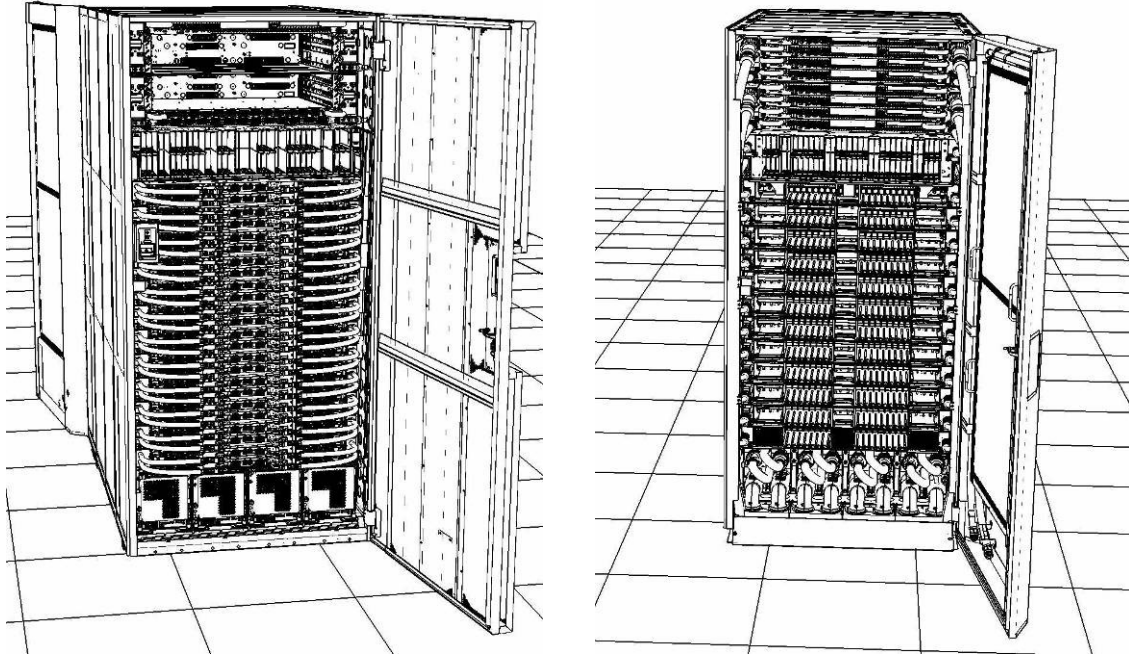

3. Bring the FDT to the front side of the **Power 775** frame that requires service.
4. Locate the panel of the FDT that contains the Universal Power and Information Cable (UPIC), as well as the **TS**, **TR**, and **TEST** water connections.

This side of the tool should be facing the front of the frame.

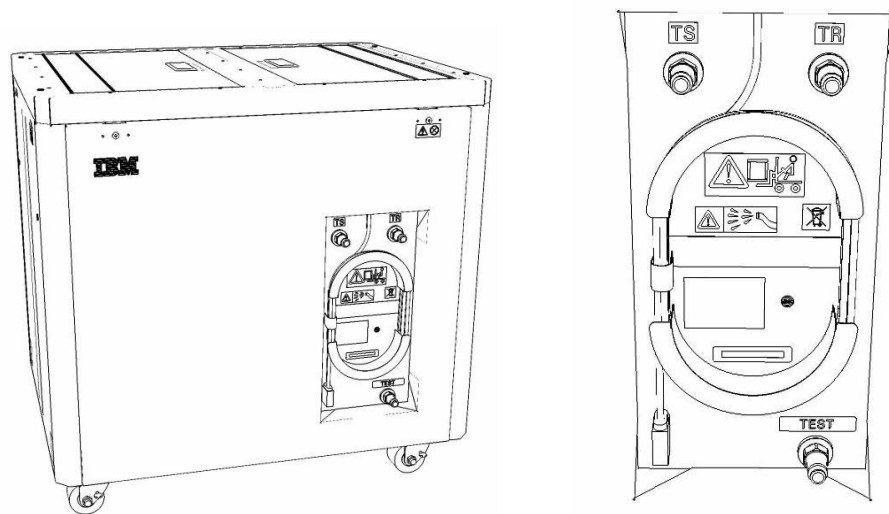

5. Unwrap the FDT UPIC cable from the storage loop on the FDT.

6. Select BPC port for FDT

- If the lower BPA is not targeted for service, and is functional:
 Plug the FDT UPIC cable into **port T10 of the lower BPC.**
- If the lower BPA is targeted for service, or is not functional:
 Plug the FDT UPIC cable into **port T10 of the upper BPC.**

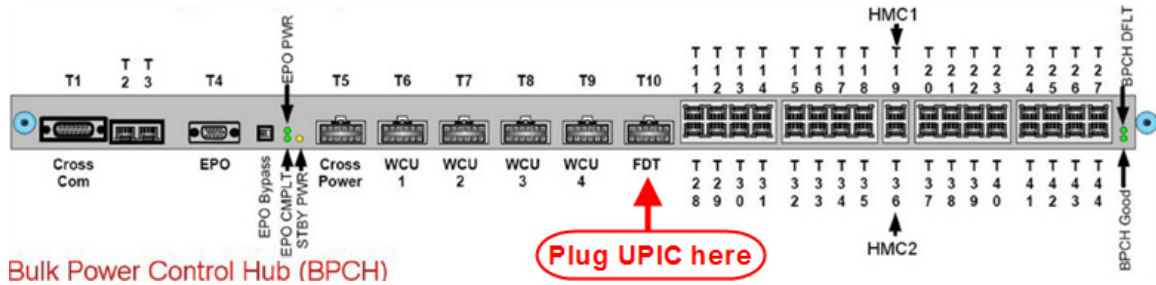

7. Login to the HMC with the User ID **hscroot**.

Use the HMC that is connected to the BPA where the FDT is plugged.

8. From the HMC left Navigation menu, expand **Systems Management** then select **Frames**.

Verify frame serial number for the frame to be serviced.

9. In the **Frames** view on the HMC, place a checkmark in the **Select** column for the frame to be serviced.

10. Verify that the frame **Status** is **Rack Standby/Rack Standby** or **Standby/Standby**.

- If frame **Status** reads **Rack Standby/Rack Standby** or **Standby/Standby** – OK.

Continue to next step.

- If frame **Status** does not read **Rack Standby/Rack Standby** or **Standby/Standby** – action required. Contact next level of support.

11. From the **Task** menu on the HMC, *select* **Serviceability** > **Hardware** > **Fill and Drain Tool Tasks** > **Fill and Drain Command Interface**

Power775 CEC Fill and Drain Tool (FDT) Procedures
 ---- CEC Fill Procedure ----

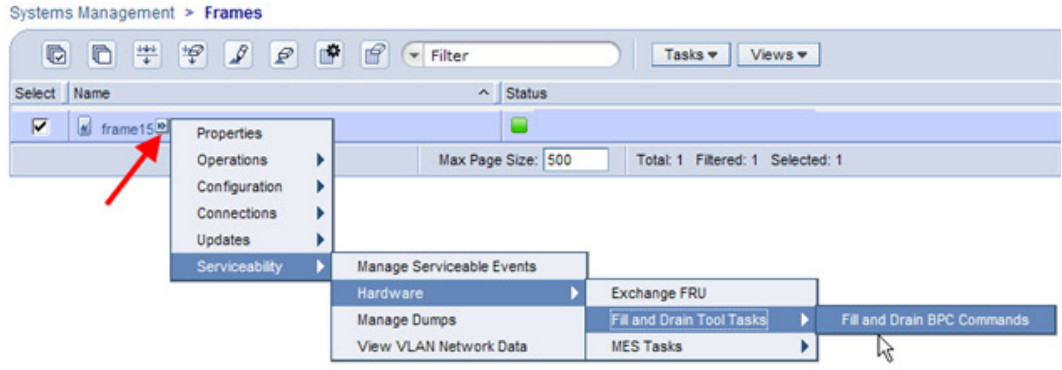

Fill and Drain Tool Command Interface will display. See below for a sample image of the interface (FDT deactivated).

Fill and Drain Tool (FDT) Command Interface - Server-78AC-100BC50029

The table below shows the FDT Port locations that can communicate with the Fill and Drain Tool. Select the port to which the Fill and Drain Tool is connected. Use the buttons to drive commands to the Fill and Drain Tool connected to a port.

FDT Port Locations:

Select	Location Code	Description
<input type="radio"/>	78AC-100*BC50029-P7-C1	Lower BPC Port T10
<input type="radio"/>	78AC-100*BC50029-P8-C1	Upper BPC Port T10

Activate FDT Deactivate FDT
Get FDT Status Decode Error Status
Fill FDT Drain FDT
Start Water Pump Reset FDT Start Air Pump
Pressure Test Calibration Component Pressure Test

Launch WCU Commands
WCU Tank Air Purge

Exit Help

12. Select the BPC port that the FDT was plugged into in **Step 6** from the **FDT Port Locations:** list.

13. *Click* the **Activate FDT** button.

- If the Activate FDT command is successful – OK. **Wait 30 seconds and continue to next step.**
- If the **Activate FDT** command fails – action required.

Click the **Deactivate FDT** button.

Wait 2 minutes and repeat **Step 13**. If the **Activate** command fails again, contact next level of support.

14. *Click* the **Get FDT Status** button.

- If the **Get FDT Status** command is successful – OK.

See below for a sample status (does not reflect expected state)

- If the **Get FDT Status** command fails – action required.

Repeat **Step 14**. If the **Get FDT Status** command fails again, contact next level of support.

Fill and Drain Tool (FDT) Command Interface - Server-78AC-100BC50029

The table below shows the FDT Port locations that can communicate with the Fill and Drain Tool. Select the port to which the Fill and Drain Tool is connected. Use the buttons to drive commands to the Fill and Drain Tool connected to a port.

FDT Port Locations:

Select	Location Code	Description
<input checked="" type="radio"/>	78AC-100*BC50029-P7-C1	Lower BPC Port T10
<input type="radio"/>	78AC-100*BC50029-P8-C1	Upper BPC Port T10

FDT Power/Comm: GOOD
 Frame Attached: IBM Power7 775
 MDA-FD RL: 45D
 Error Status: WARNING
 Tank Level: Full
 Air Pump: Off
 Water Pump: DISABLED
 Tool Mode: Ready
 Pressure Test Calibration: Incomplete
 Component Pressure Test: Incomplete

Sample FDT Status

15. Review the FDT status screen and ensure that the following status items are OK:

Status Item	State	Action
-------------	-------	--------

- **Tool Mode:** **Ready** – OK. Check next Status item.
- **Error Status:** **NONE** – OK. Check next Status item.
WARNING – *click the **Decode Error Status** button, record the information returned and check Tank Level.*
CRITICAL – *click the **Decode Error Status** button, record the information returned and contact next level of support.*
- **Tank Level:** **Full** or **Upper Half** – OK. Check next Status item.

Lower Half or Empty – action required.

Exit this procedure and perform a **Fill and Drain Tool (FDT) Tank Fill Procedure**.

Once FDT tank level is **Full** or **Upper Half**, return to this step and continue with procedure.

- **Component Pressure Test: Pass** – OK. Proceed to next step.

This procedure **should not** be continued if the component pressure test did not **Pass**.

Incomplete or Fail – action required.

Exit this procedure and complete a **CEC Pressure Test Procedure**.

Once a **passing** result is confirmed, return to this step and continue with procedure.

16. Verify all CEC DCCA water hoses are connected to the CEC being serviced.

CEC DCCA must be installed in CEC during fill procedure.

17. Verify CEC water connections **are not** connected to system manifolds.

18. Before proceeding, read required safety information:

CAUTION: The water-based coolant solution may contain an additive intended to inhibit corrosion (or provide other functions). The solution may cause irritation to the skin or eyes. Avoid direct contact with the solution. Employ appropriate Personal Protective Equipment when performing operations involving the coolant or which may potentially expose you to the coolant. Refer to the MSDS for more information. (C037)



CAUTION: Protective eyewear is needed for the procedure. (L011)



CAUTION: Chemical resistant gloves are needed for this procedure. (L014)

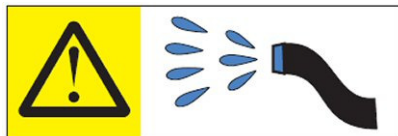

DANGER: Risk of electric shock due to water or a water solution which is present in this product. Avoid working on or near energized equipment with wet hands or when spilled water is present. (L016)

19. Remove hose assembly **HA1** from the upper tool storage compartment.

Connect either end of hose assembly **HA1** to the **TS** connection on the front panel of the FDT.

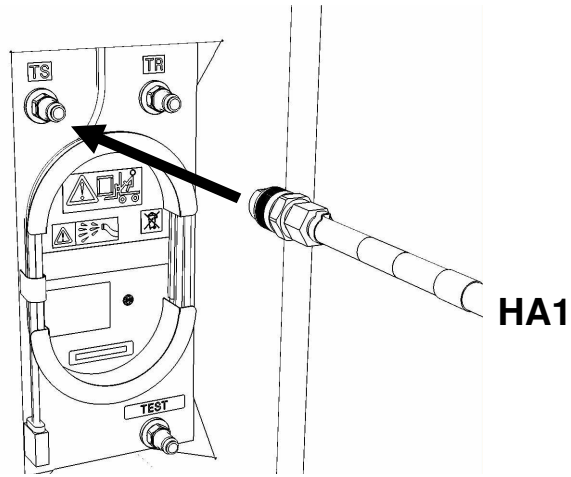

20. Remove hose assembly **HA2** from the upper tool storage compartment.
Connect end *without sight glass* to the **TR** connection on the FDT.

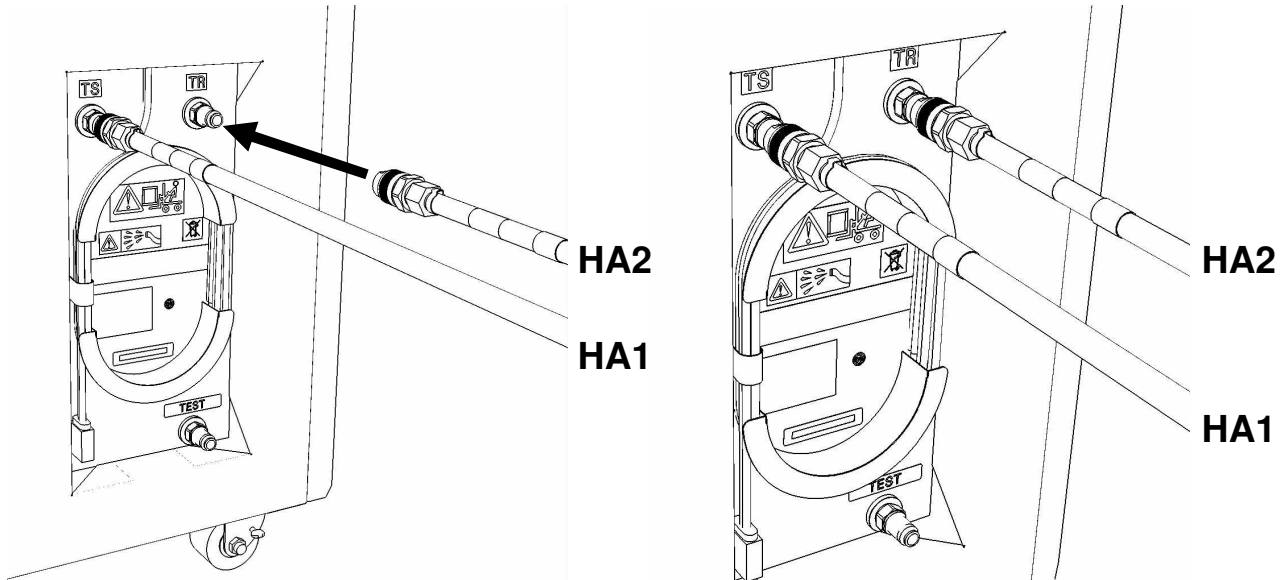

21. Verify CEC position for fill procedure.

- If the CEC is not installed system – OK. Continue to next step.
- If the CEC is installed in the system – action required.

Pass the unattached ends of **HA1** and **HA2** to the rear of the frame.

NOTE: Hose assemblies **HA1** and **HA2** can be passed **around** the frame or **over** the frame, depending on frame position. These hoses are long enough to complete all FDT service actions on the rear of the frame.

22. Connect **HA1** hose assembly to the left side CEC water connection.

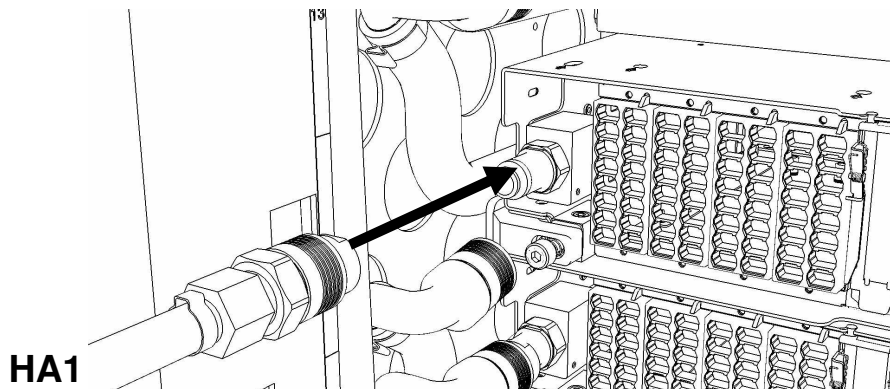

23. Connect **HA2** hose assembly to the right side CEC water connection.

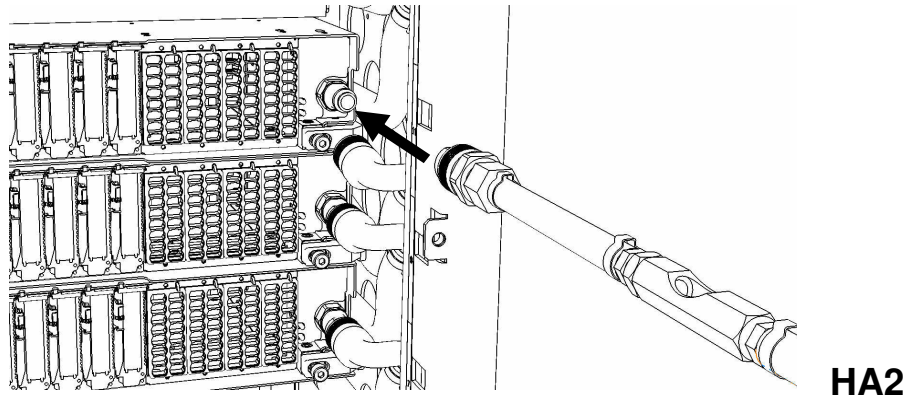

24. Ensure all hose connections are made properly and securely.
Verify hoses are connected as outlined in the schematic below.

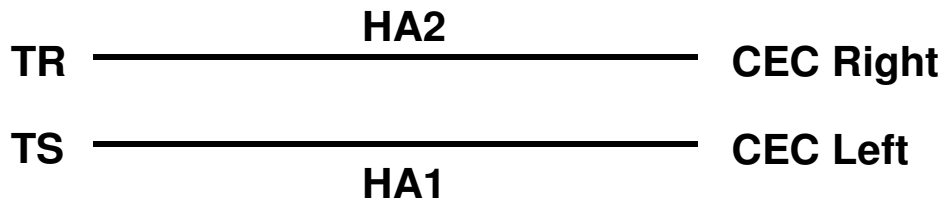

25. On the FDT panel, *click* the **Start Water Pump** button.

The **Get FDT Status** button may be *clicked* to examine FDT status.

NOTE: *The water pump will shut off after 30 minutes of run time.*

Approximate time to fill a CEC: 60 seconds.

CAUTION: This unit must not be left running unattended, service personnel should always be overseeing the process. (C038)

26. Inspect the sight glass in hose assembly **HA2** while the water pump is running.

The sight glass will indicate the filling status of this step.

Expected sight glass behavior

- Sight glass will start out full of air while the component is being purged of air.
- After some period of time, water will start passing through the sight glass in an air/water mixture.
- Eventually the sight glass will become full of water, with intermittent small air bubbles.

Full sight glass definition

- The sight glass is considered full of water **when** water flow is obvious (white ball pinned in direction of FDT) **and** no large bubbles of air are observed.
- If the above description is observed and the water appears cloudy, this is also considered full.

27. If the water pump has stopped unexpectedly without *clicking* the **Reset FDT** button:

Click Get Status and ensure that the following status items are OK:

<u>Status Item</u>	<u>State</u>	<u>Action</u>
• Tool mode:	Ready – OK.	Check next Status item.
	Tool mode: System/Component Fill Mode – water pump still running.	Proceed to Step 27 .
• Tank Level:	Full, Upper Half, or Lower Half – OK.	Check next Status item.
	Empty – action required.	FDT tank fill required.
		Exit this procedure and complete a Fill and Drain Tool (FDT) Tank Fill Procedure .
		Once FDT tank level is Full or Upper Half return to Step 18 and continue with procedure.
• Error Status:	NONE – OK.	Proceed to next step.
	WARNING – <i>click</i> the Decode Error Status button,	record information returned and proceed to next step.
	CRITICAL – <i>click</i> the Decode Error Status button,	record information returned and contact next level of support.

28. If the sight glass in **HA2** never becomes full of water:

Ensure all hose connections in **Step 18** through **Step 23** are made properly.

Complete the diagnostics in **Step 26**.

- If the sight glass in **HA2** becomes full of water, continue with procedure.
- If the sight glass in **HA2** does not become full of water, contact next level of support.

29. When the sight glass in **HA2** has been mostly solid water for 60 seconds:

Click the **Reset FDT** button.

30. Click Get Status and ensure that the following status items are OK:

<u>Status Item</u>	<u>State</u>	<u>Action</u>
• Tool mode:	Ready – OK.	Check next Status item.
	System/Component Fill Mode – water pump still running.	Repeat Step 28 .
• Error Status:	NONE – OK.	Proceed to next step.
	WARNING – <i>click</i> the Decode Error Status button, record information returned and proceed to next step.	
	CRITICAL – <i>click</i> the Decode Error Status button, record information returned and contact next level of support.	

31. The CEC fill procedure has completed successfully.

The CEC can be connected to the system manifolds.

32. Disconnect **HA1** assembly from the left side CEC water connection.

Power775 CEC Fill and Drain Tool (FDT) Procedures
---- CEC Fill Procedure ----

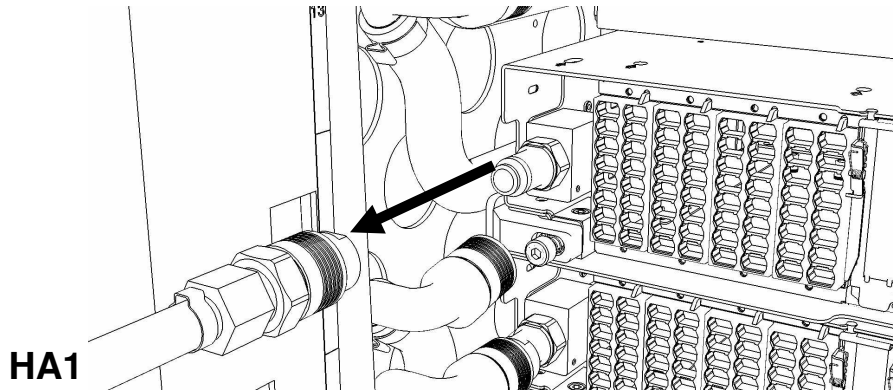

33. Disconnect **HA2** assembly from the right side CEC water connection.

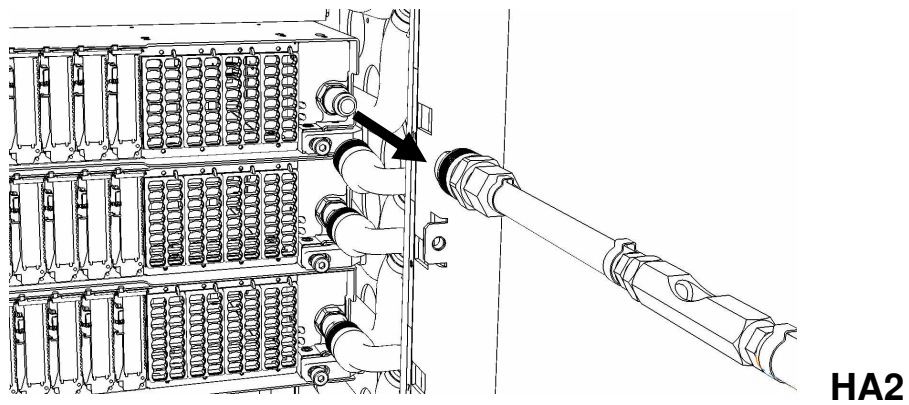

34. Connect the system manifold hoses to the CEC water connections.

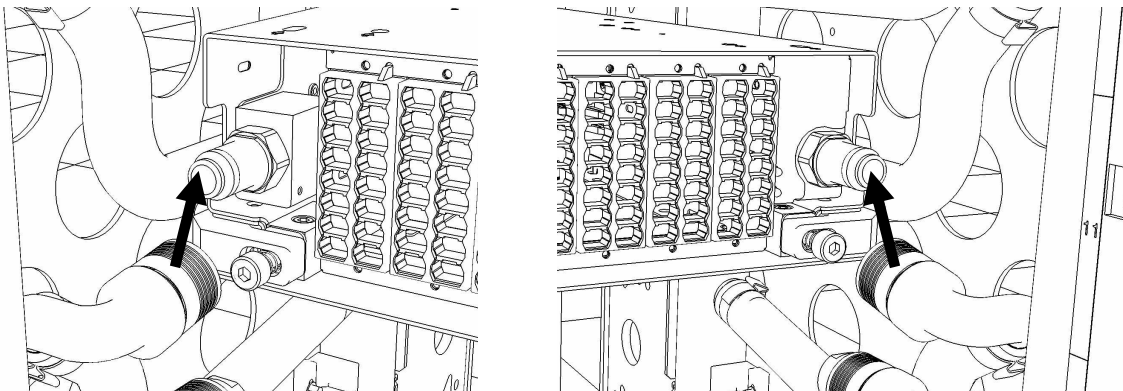

35. Disconnect the FDT end of **HA1** from **TS** on the FDT.

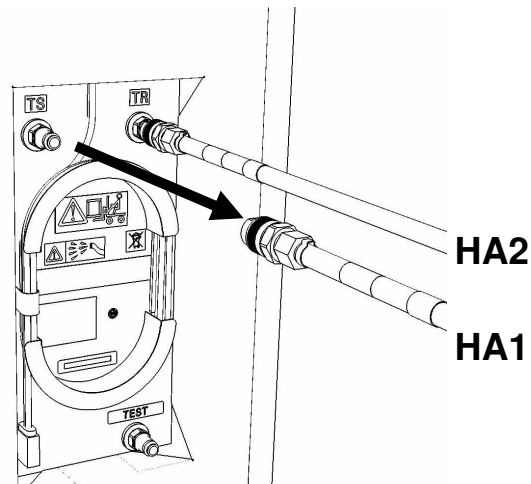

36. Disconnect the FDT end of **HA2** from **TR** on the FDT.

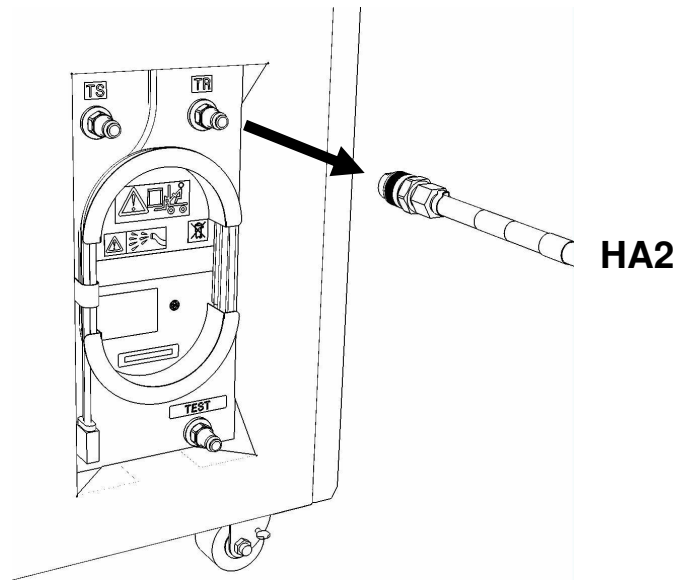

37. Place all hose assemblies and adapters in their appropriate locations within the FDT storage enclosure.

38. Determine whether the FDT will be used for another procedure:

- If the FDT will be used for another procedure, leave tool activated and go to that procedure now; skip the remaining steps of this procedure.
- If the FDT requires no further use - proceed to the next step.

39. *Click* the **Deactivate FDT** button.

- If the **Deactivate FDT** command is successful – OK. Proceed to next step.
- If the **Deactivate FDT** command fails– action required.

Repeat **Deactivate FDT**. If the **Deactivate FDT** command fails again, contact next level of support.

40. Disconnect FDT UPIC power cable from port T10 of BPC used.

Wrap the UPIC cable in appropriate cable storage location on FDT.

41. If this procedure was referenced from another procedure, return to parent procedure.

3.4 End of Power775 CEC Fill Procedure

4 POWER775 CEC PRESSURE TEST PROCEDURE

4.1 Safety Notices

Read “Safety Notices“ available from InfoCenter:

<http://publib.boulder.ibm.com/infocenter/powersys/v3r1m5/topic/p7hdx/G229-9054.pdf>

The following cautions apply to all Power775 service procedures:

CAUTION:

Energy hazard present and Shorting might result in system outage and possible physical injury. Remove all metallic jewelry before servicing. (C001)

CAUTION:

The doors and covers to the product are to be closed at all times except for service by trained service personnel. All covers must be replaced and doors locked at the conclusion of the service operation. (C013)

CAUTION:

Servicing of this product or unit is to be performed by trained service personnel only. (C032)

The following notices specifically pertain to this Power775 service procedure.

CAUTION: The water-based coolant solution may contain an additive intended to inhibit corrosion (or provide other functions). The solution may cause irritation to the skin or eyes. Avoid direct contact with the solution. Employ appropriate Personal Protective Equipment when performing operations involving the coolant or which may potentially expose you to the coolant. Refer to the MSDS for more information. (C037)

CAUTION: This unit must not be left running unattended, service personnel should always be overseeing the process. (C038)



DANGER: Hazardous voltage present. Voltages present constitute a shock hazard, which can cause severe injury or death. (L004)



CAUTION: Protective eyewear is needed for the procedure. (L011)



DANGER: Heavy equipment—personal injury or equipment damage might result if mishandled. (L013)



CAUTION: Chemical resistant gloves are needed for this procedure. (L014)

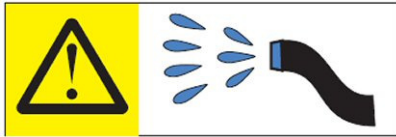

DANGER: Risk of electric shock due to water or a water solution which is present in this product. Avoid working on or near energized equipment with wet hands or when spilled water is present. (L016)

4.2 Background:

This document contains the procedure for performing an air pressure test on a Central Electronics Complex (CEC) on an **IBM Power 775** system, using an **IBM Power 775** Fill and Drain Tool (FDT). The successful execution of a **FDT Pressure Test Calibration** procedure is required for this procedure to be performed.

To ensure that all **IBM Power 775** water-cooled CEC's are leak-free, the **IBM Power 775** Fill and Drain Tool (FDT) is equipped with pressure testing capability. The CEC pressure test is designed to identify leaks in the CEC internal plumbing, and must be completed before a CEC fill procedure is executed so that any potential for water leakage in the system can be avoided.

The results of the CEC pressure test are recorded within the FDT; if the test passes, a CEC fill procedure can be completed. If this test fails, there is a functional defect in the CEC, and the component fill cannot be completed. Upon a pressure test failure of a component, the next level of support must be contacted to replace the hardware.

A CEC fill procedure should not be executed unless both the **FDT Pressure Test Calibration** and **CEC Pressure Test** have passed since FDT activation.

The pressure test must be completed on an empty CEC. A new CEC should ship without water to the customer location, and no additional drainage is required. If the FDT senses that the CEC is not empty when the pressure test begins, the pressure test will stop. The pressure test status will be set as incomplete, and a CEC drain operation will be required.

Reference Information:

IBM Power 775 FDT P/N:	45D6928
Hose assemblies/adapters required:	HA1 (45D8561) HA2 (45D8562)

Expected maximum time to complete CEC pressure test: 4 min

NOTE: *Some steps in this procedure may be redundant due to other service operations being completed prior to this procedure. If a step has already been completed, verify that the step has been completed properly and proceed to the next step.*

NOTE: *The location of the component for the pressure test procedure is not important. The pressure test can be completed with the component on a cart, on the lift tool, or mechanically installed in the frame.*

4.3 Procedure:

NOTE: If you already have the FDT powered on, proceed to **Step 14**. Otherwise, start procedure at **Step 1**.

Power775 CEC Fill and Drain Tool (FDT) Procedures
---- CEC Pressure Test Procedure ----

1. Identify the **Power 775** frame that requires service.

Verify that the system UEPO is set to **ON**, and the managing consoles (HMC and XCat) are powered on and communicating with the frame.

2. Open front and rear doors of the **Power 775** frame that requires service.

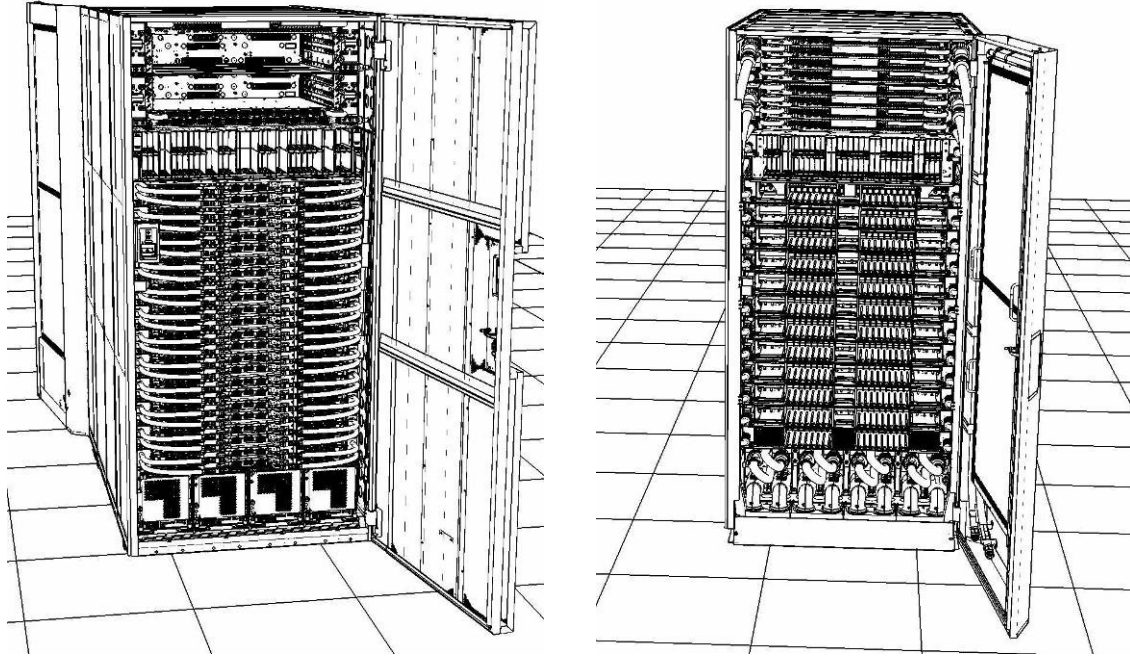

3. Bring the FDT to the front side of the **Power 775** frame that requires service.
4. Locate the panel of the FDT that contains the Universal Power and Information Cable (UPIC), as well as the **TS**, **TR**, and **TEST** water connections.

This side of the tool should be facing the front of the frame.

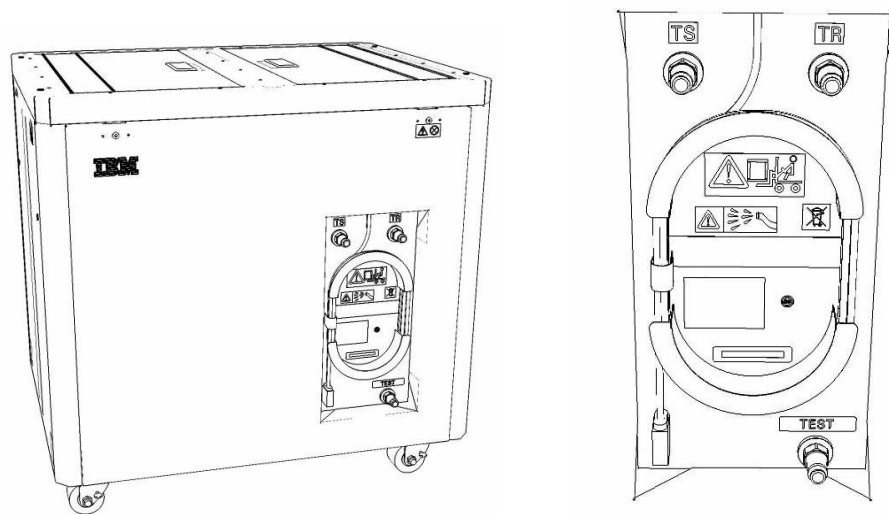

5. Unwrap the FDT UPIC cable from the storage loop on the FDT.

6. Select BPC port for FDT

- If the lower BPA is not targeted for service, and is functional:
 Plug the FDT UPIC cable into **port T10 of the lower BPC.**
- If the lower BPA is targeted for service, or is not functional:
 Plug the FDT UPIC cable into **port T10 of the upper BPC.**

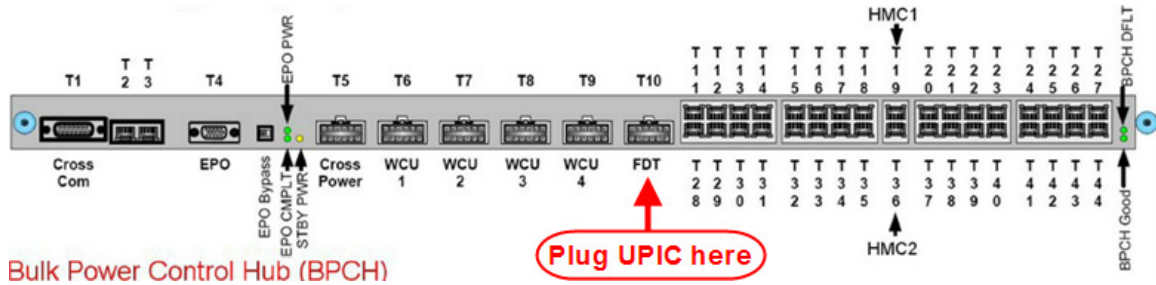

7. Login to the HMC with the User ID **hscroot**.

Use the HMC that is connected to the BPA where the FDT is plugged.

8. From the HMC left Navigation menu, expand **Systems Management** then select **Frames**.

Verify frame serial number for the frame to be serviced.

9. In the **Frames** view on the HMC, place a checkmark in the **Select** column for the frame to be serviced.

10. Verify that the frame **Status** is **Rack Standby/Rack Standby** or **Standby/Standby**.

- If frame **Status** reads **Rack Standby/Rack Standby** or **Standby/Standby** – OK.

Continue to next step.

- If frame **Status** does not read **Rack Standby/Rack Standby** or **Standby/Standby** – action required. Contact next level of support.

11. From the **Task** menu on the HMC, *select* **Serviceability** > **Hardware** > **Fill and Drain Tool Tasks** > **Fill and Drain Command Interface**

Power775 CEC Fill and Drain Tool (FDT) Procedures
 ---- CEC Pressure Test Procedure ----

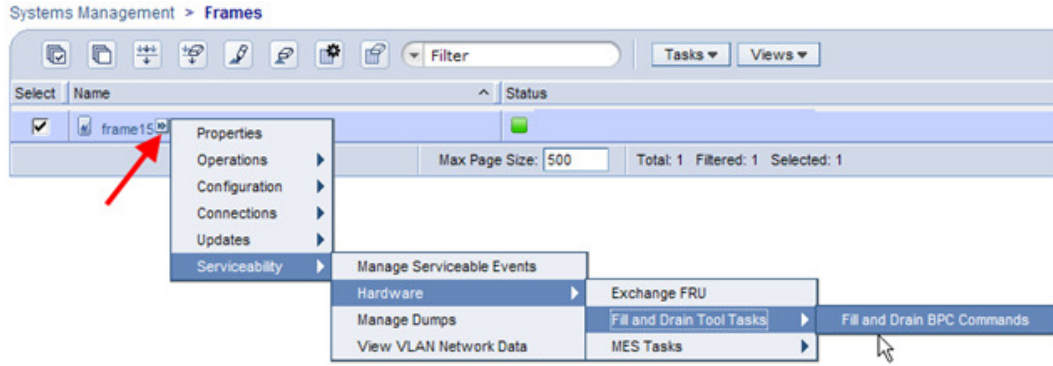

Fill and Drain Tool Command Interface will display. See below for a sample image of the interface (FDT deactivated).

Fill and Drain Tool (FDT) Command Interface - Server-78AC-100BC50029

The table below shows the FDT Port locations that can communicate with the Fill and Drain Tool. Select the port to which the Fill and Drain Tool is connected. Use the buttons to drive commands to the Fill and Drain Tool connected to a port.

FDT Port Locations:

Select	Location Code	Description
<input type="radio"/>	78AC-100*BC50029-P7-C1	Lower BPC Port T10
<input type="radio"/>	78AC-100*BC50029-P8-C1	Upper BPC Port T10

Activate FDT Deactivate FDT
Get FDT Status Decode Error Status
Fill FDT Drain FDT
Start Water Pump Reset FDT Start Air Pump
Pressure Test Calibration Component Pressure Test

Launch WCU Commands WCU Tank Air Purge
Exit Help

12. Select the BPC port that the FDT was plugged into in **Step 6** from the **FDT Port Locations:** list.

13. *Click* the **Activate FDT** button.

- If the Activate FDT command is successful – OK. **Wait 30 seconds and continue to next step.**
- If the **Activate FDT** command fails – action required.

Click the **Deactivate FDT** button.

Wait 2 minutes and repeat **Step 13**. If the **Activate** command fails again, contact next level of support.

14. *Click* the **Get FDT Status** button.

- If the **Get FDT Status** command is successful – OK.

See below for a sample status (does not reflect expected state)

- If the **Get FDT Status** command fails – action required.

Repeat **Step 14**. If the **Get FDT Status** command fails again, contact next level of support.

Fill and Drain Tool (FDT) Command Interface - Server-78AC-100BC50029

The table below shows the FDT Port locations that can communicate with the Fill and Drain Tool. Select the port to which the Fill and Drain Tool is connected. Use the buttons to drive commands to the Fill and Drain Tool connected to a port.

FDT Port Locations:

Select	Location Code	Description
<input checked="" type="radio"/>	78AC-100*BC50029-P7-C1	Lower BPC Port T10
<input type="radio"/>	78AC-100*BC50029-P8-C1	Upper BPC Port T10

FDT Power/Comm: GOOD
 Frame Attached: IBM Power7 775
 MDA-FD RL: 45D
 Error Status: WARNING
 Tank Level: Full
 Air Pump: Off
 Water Pump: DISABLED
 Tool Mode: Ready
 Pressure Test Calibration: Incomplete
 Component Pressure Test: Incomplete

Sample FDT Status

15. Review the FDT status screen and ensure that the following status items are OK:

Status Item	State	Action
-------------	-------	--------

- **Tool Mode:** **Ready** – OK. Check next Status item.
- **Error Status:** **NONE** – OK. Check next Status item.
WARNING – *click the **Decode Error Status** button, record the information returned and check Tank Level.*
CRITICAL – *click the **Decode Error Status** button, record the information returned and contact next level of support.*
- **Tank Level:** **Upper Half, Lower Half or Empty**– OK.

Full – action required.

Exit this procedure and complete a **Fill and Drain Tool (FDT) Tank Drain Procedure**.

Once FDT tank level is **Upper Half**, **Lower Half** or **Empty**, return to this step and continue with procedure.

- **Pressure Test Calibration:** **Pass** - OK. Check next Status item.
Incomplete or **Fail** – action required.
Exit this procedure and complete the **Pressure Test Calibration** procedure.
Once a **passing** result is confirmed, return to this step and continue with procedure.
- **Component Pressure Test:** **Incomplete** – OK. Continue to next step.
Pass or **Fail** – action required.
Click the **Reset FDT** button and proceed to next step.

16. Verify that CEC water connections **are not** connected to system manifolds.
CEC should be drained of water.

17. Before proceeding, read required safety information:

CAUTION: The water-based coolant solution may contain an additive intended to inhibit corrosion (or provide other functions). The solution may cause irritation to the skin or eyes. Avoid direct contact with the solution. Employ appropriate Personal Protective Equipment when performing operations involving the coolant or which may potentially expose you to the coolant. Refer to the MSDS for more information. (C037)



CAUTION: Protective eyewear is needed for the procedure. (L011)



CAUTION: Chemical resistant gloves are needed for this procedure. (L014)

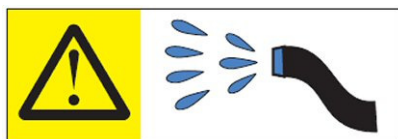

DANGER: Risk of electric shock due to water or a water solution which is present in this product. Avoid working on or near energized equipment with wet hands or when spilled water is present. (L016)

18. Verify CEC position for pressure test procedure.

- If the CEC is not installed system – OK. Continue to next step.
- If the CEC is installed in the system – action required.

Pass the unattached ends of **HA1** and **HA2** to the rear of the frame.

NOTE: Hose assemblies **HA1** and **HA2** can be passed **around** the frame or **over** the frame, depending on frame position. These hoses are long enough to complete all FDT service actions on the rear of the frame.

19. Remove hose assembly **HA1** from the upper tool storage compartment.

Connect either end of hose assembly **HA1** to the **TEST** connection on the front panel of the FDT.

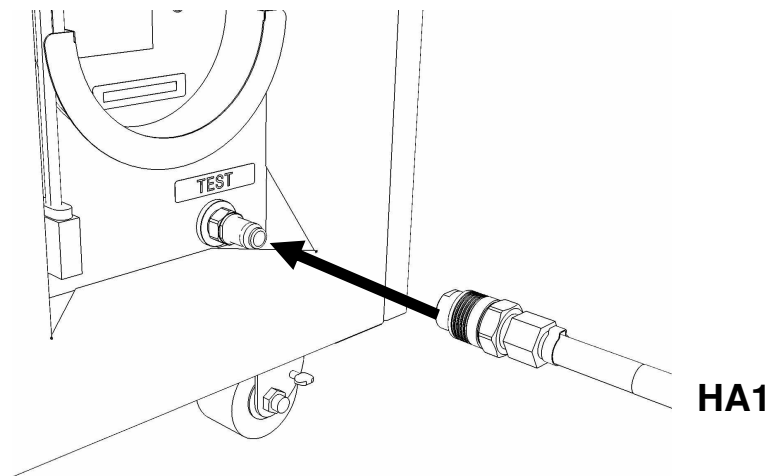

20. Remove hose assembly **HA2** from the upper tool storage compartment.

Connect end *without sight glass* to the **TR** connection on the FDT.

Power775 CEC Fill and Drain Tool (FDT) Procedures
---- CEC Pressure Test Procedure ----

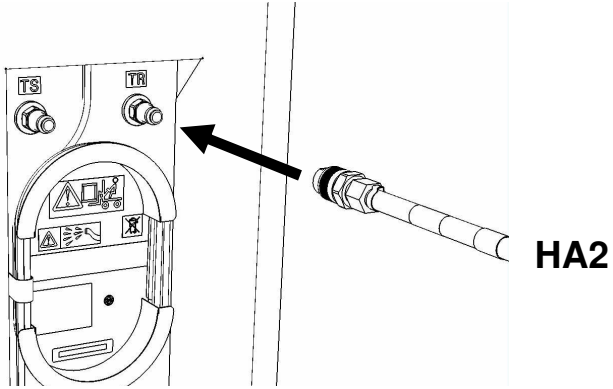

21. Connect **HA1** hose assembly to the left side CEC water connection.

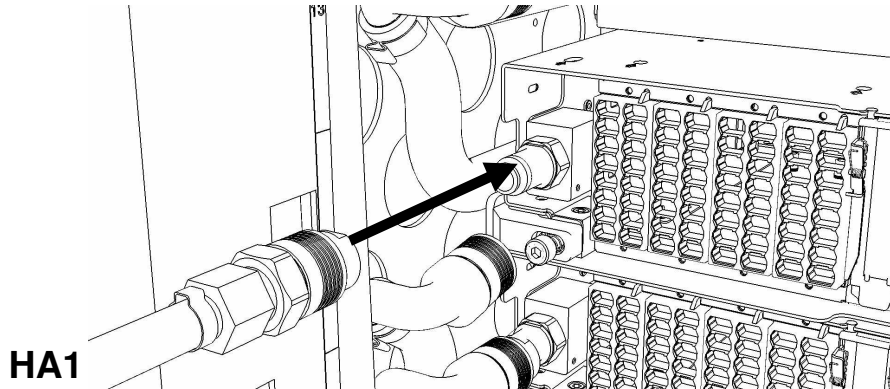

22. Connect **HA2** hose assembly to the right side CEC water connection.

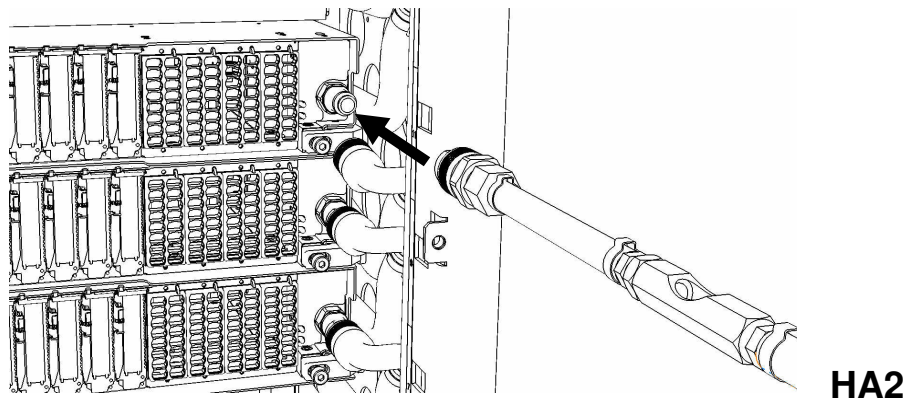

23. Ensure all hose connections are made properly and securely.
Verify hoses are connected as outlined in the schematic below.

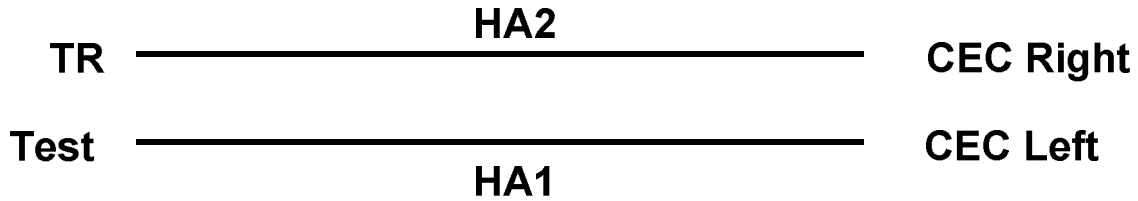

24. On the FDT Panel, *click* the **Component Pressure Test** button.

The **Get FDT Status** button may be *clicked* to examine FDT status.

NOTE: *The pressure testing will last for 4 minutes (2 minutes with air pump on)*

CAUTION: **This unit must not be left running unattended, service personnel should always be overseeing the process. (C038)**

25. Click Get Status and ensure that the following status items are OK:

<u>Status Item</u>	<u>State</u>	<u>Action</u>
<ul style="list-style-type: none"> Tool mode: 	<p>Ready – OK. Check next Status item.</p> <p>System/Component Pressure Test Mode – pressure test still running.</p> <p>Wait 30 seconds and repeat Step 25.</p>	
<ul style="list-style-type: none"> Error Status: 	<p>NONE – OK. Check next Status item.</p> <p>WARNING – <i>click</i> the Decode Error Status button, record information returned and proceed to next step.</p> <p>CRITICAL – <i>click</i> the Decode Error Status button, record information returned and contact next level of support.</p>	
<ul style="list-style-type: none"> Component Pressure Test: 	<p>Pass – OK. Proceed to next step.</p> <p>Fail or Incomplete – action required.</p> <p><i>Click</i> the Reset FDT button.</p> <p>Repeat Step 19 through Step 24 and continue with procedure.</p> <p>If the test read Fail twice, hardware is defective. Contact next level of support.</p>	

26. The component pressure test has passed successfully.

If required, a CEC fill procedure can now be completed.

NOTE: If a **CEC Fill Procedure** will be completed following this test, disregard **Step 27 - 31**. These hose connections will be the same in the CEC fill procedure.

27. Disconnect **HA1** assembly from the left side CEC water connection.

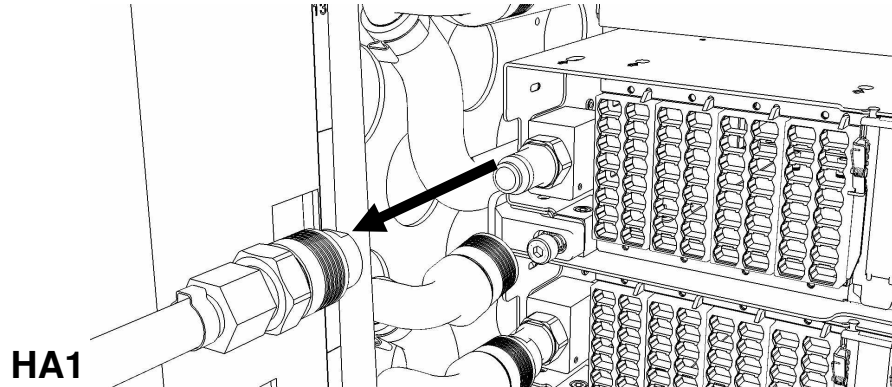

28. Disconnect **HA2** assembly from the right side CEC water connection.

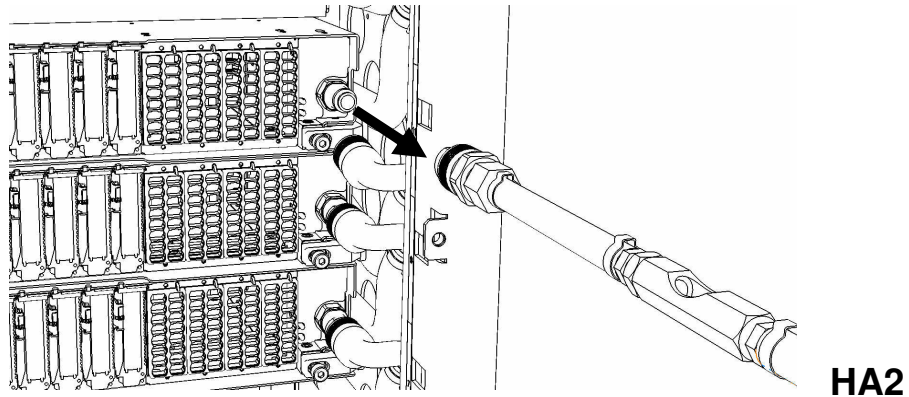

29. Disconnect the FDT end of **HA1** from **TEST** on the FDT.

Power775 CEC Fill and Drain Tool (FDT) Procedures
---- CEC Pressure Test Procedure ----

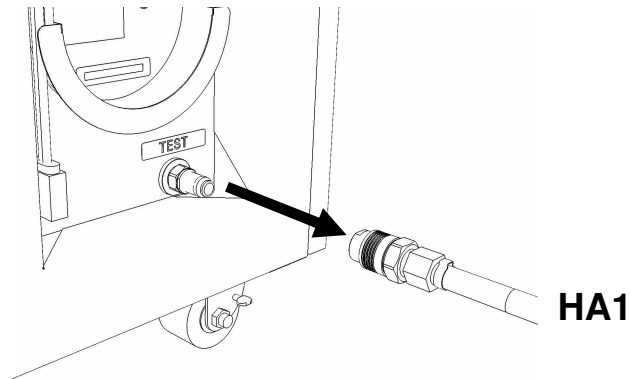

30. Disconnect the FDT end of **HA2** from **TR** on the FDT.

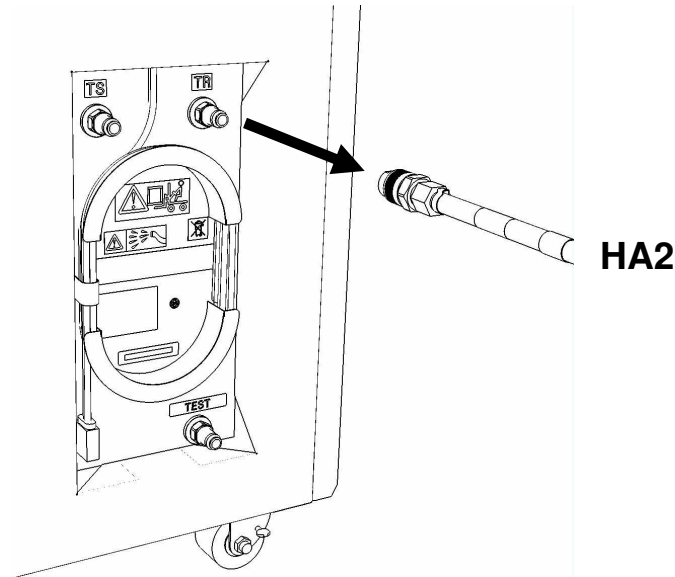

31. Place all hose assemblies and adapters in their appropriate locations within the FDT storage enclosure.

32. Determine whether the FDT will be used for another procedure:

- If the FDT will be used for another procedure, leave tool activated and go to that procedure now; skip the remaining steps of this procedure.
- If the FDT requires no further use - proceed to the next step.

33. Click the **Deactivate FDT** button.

- If the **Deactivate FDT** command is successful – OK. Proceed to next step.

- If the **Deactivate FDT** command fails— action required.
Repeat **Deactivate FDT**. If the **Deactivate FDT** command fails again, contact next level of support.
34. Disconnect FDT UPIC power cable from port T10 of BPC used.
Wrap the UPIC cable in appropriate cable storage location on FDT.
35. If this procedure was referenced from another procedure, return to parent procedure.

4.4 End of Power775 CEC Pressure Test Procedure

5 POWER775 FILL AND DRAIN TOOL (FDT) TANK DRAIN PROCEDURE

5.1 Safety Notices

Read "Safety Notices" available from InfoCenter:

<http://publib.boulder.ibm.com/infocenter/powersys/v3r1m5/topic/p7hdx/G229-9054.pdf>

The following cautions apply to all Power775 service procedures:

CAUTION:

Energy hazard present and Shorting might result in system outage and possible physical injury. Remove all metallic jewelry before servicing. (C001)

CAUTION:

The doors and covers to the product are to be closed at all times except for service by trained service personnel. All covers must be replaced and doors locked at the conclusion of the service operation. (C013)

CAUTION:

Servicing of this product or unit is to be performed by trained service personnel only. (C032)

The following notices specifically pertain to this Power775 service procedure.

CAUTION: The water-based coolant solution may contain an additive intended to inhibit corrosion (or provide other functions). The solution may cause irritation to the skin or eyes. Avoid direct contact with the solution. Employ appropriate Personal Protective Equipment when performing operations involving the coolant or which may potentially expose you to the coolant. Refer to the MSDS for more information. (C037)

CAUTION: This unit must not be left running unattended, service personnel should always be overseeing the process. (C038)



DANGER: Hazardous voltage present. Voltages present constitute a shock hazard, which can cause severe injury or death. (L004)



CAUTION: Protective eyewear is needed for the procedure. (L011)

Power775 Bulk Power Distributor (BPD) Fill and Drain Tool Procedures:
---- FDT Tank Drain Procedure ----



DANGER: Heavy equipment—personal injury or equipment damage might result if mishandled.
(L013)



CAUTION: Chemical resistant gloves are needed for this procedure. (L014)

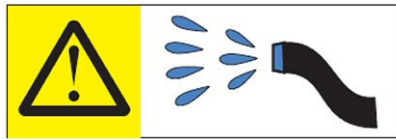

DANGER: Risk of electric shock due to water or a water solution which is present in this product.
Avoid working on or near energized equipment with wet hands or when spilled water is present.
(L016)

5.2 Background:

This document contains the procedure for draining the water out of the internal reservoir of an **IBM Power 775** Fill and Drain Tool (FDT).

The FDT is used to transfer water into and out of various components of the **IBM Power 775** system. When a system component or the entire system is drained, the water will be transferred into the tank (internal reservoir) within the FDT. During drain operations, the FDT tank may become full, and if so, will need to be periodically emptied into the supplied system water containers. The FDT Tank Drain Procedure instructs the user to properly transfer water out of the FDT Tank and into an empty system water container.

During system or component drain operations, if the FDT senses that the internal reservoir has become full, it will terminate any running drain routine, as well as prevent any further drain routines from being executed. This may occur during a system or component drain procedure; if so, the system or component drain procedure must be paused, and this FDT Tank Drain Procedure must be completed before system/component draining can resume. Individual system water containers treated with a corrosion inhibitor are shipped with the system and after the initial system fill, the empty containers must be stored to be available for the FDT Tank Drain operation.

The system water is treated and must not be poured down a sink or on the ground.

Reference Information:

IBM Power 775 FDT P/N: **45D6928**
IBM System Water Container P/N: **45D2124** (U.S.), **45D2129** (non-U.S.)
Hose assemblies/adapters required: **THA** (45D8563)

Approximate FDT internal water volume: 32 L

Expected drainage time for one (1) system water container: 1 min, 40 s

NOTE: *Some steps in this procedure may be redundant due to other service operations being completed prior to this procedure. If a step has already been completed, verify that the step has been completed properly and proceed to the next step.*

5.3 Procedure:

NOTE: If you already have the FDT powered on, proceed to **Step 14**. Otherwise, start procedure at **Step 1**.

Power775 Bulk Power Distributor (BPD) Fill and Drain Tool Procedures:
---- FDT Tank Drain Procedure ----

1. Identify the **Power 775** frame that requires service.

Verify that the system UEPO is set to **ON**, and the managing consoles (HMC and XCat) are powered on and communicating with the frame.

2. Open front and rear doors of the **Power 775** frame that requires service.

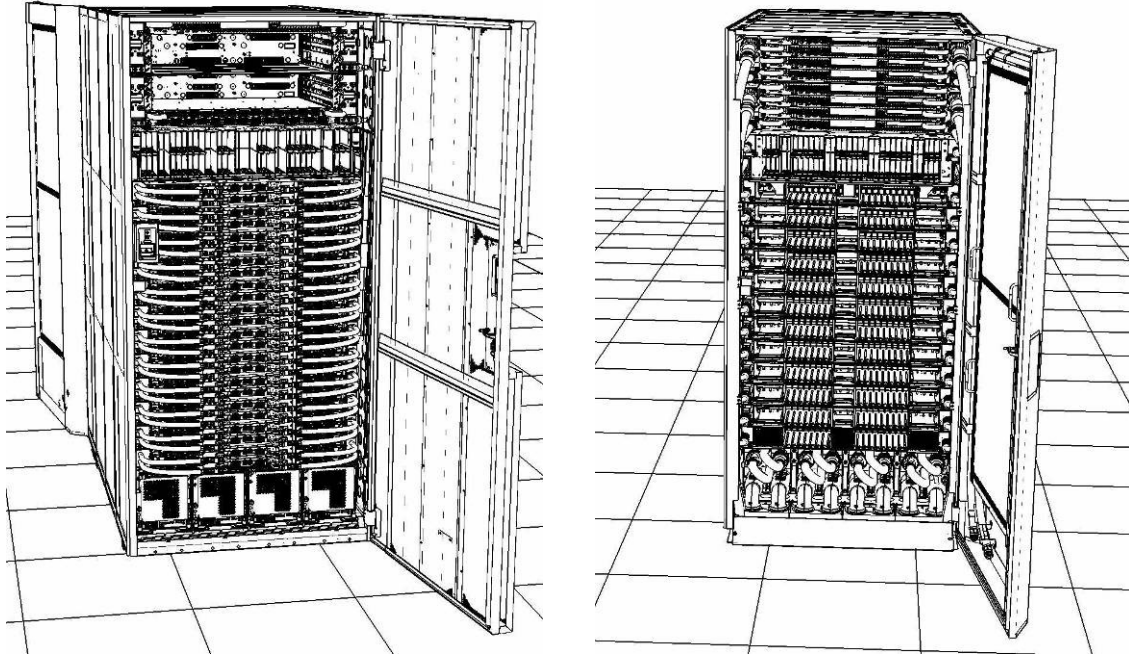

3. Bring the FDT to the front side of the **Power 775** frame that requires service.
4. Locate the panel of the FDT that contains the Universal Power and Information Cable (UPIC), as well as the **TS**, **TR**, and **TEST** water connections.

This side of the tool should be facing the front of the frame.

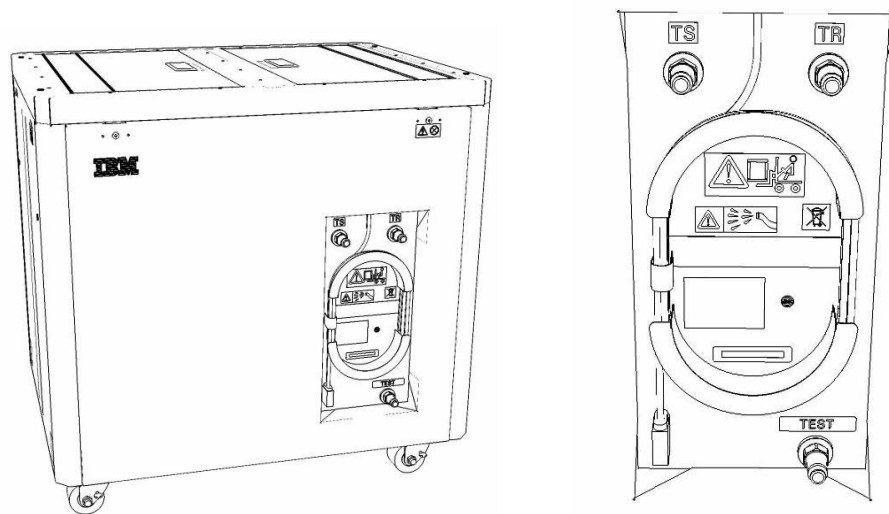

5. Unwrap the FDT UPIC cable from the storage loop on the FDT.

Power775 Bulk Power Distributor (BPD) Fill and Drain Tool Procedures:
---- FDT Tank Drain Procedure ----

6. Select BPC port for FDT

- If the lower BPA is not targeted for service, and is functional:
Plug the FDT UPIC cable into **port T10 of the lower BPC.**
- If the lower BPA is targeted for service, or is not functional:
Plug the FDT UPIC cable into **port T10 of the upper BPC.**

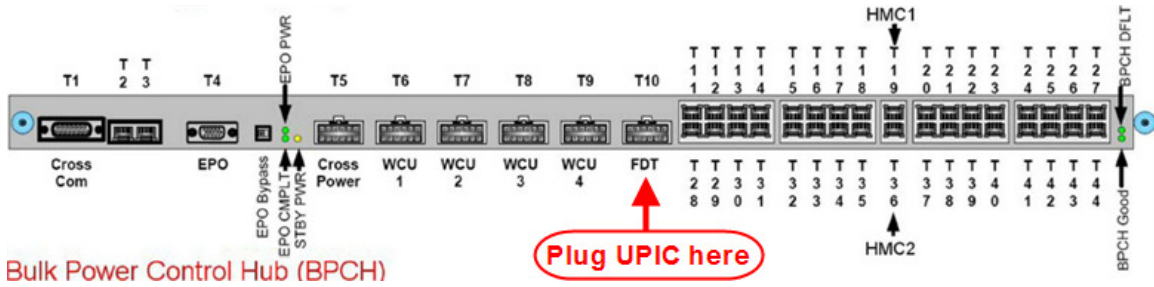

7. Login to the HMC with the User ID `hscroot`.

Use the HMC that is connected to the BPA where the FDT is plugged.

8. From the HMC left Navigation menu, expand **Systems Management** then select **Frames**.

Verify frame serial number for the frame to be serviced.

9. In the **Frames** view on the HMC, place a checkmark in the **Select** column for the frame to be serviced.

10. Verify that the frame **Status** is **Rack Standby/Rack Standby** or **Standby/Standby**.

- If frame **Status** reads **Rack Standby/Rack Standby** or **Standby/Standby** – OK.

Continue to next step.

- If frame **Status** does not read **Rack Standby/Rack Standby** or **Standby/Standby** – action required. Contact next level of support.

11. From the **Task** menu on the HMC, *select* **Serviceability** > **Hardware** > **Fill and Drain Tool Tasks** > **Fill and Drain Command Interface**

**Power775 Bulk Power Distributor (BPD) Fill and Drain Tool Procedures:
---- FDT Tank Drain Procedure ----**

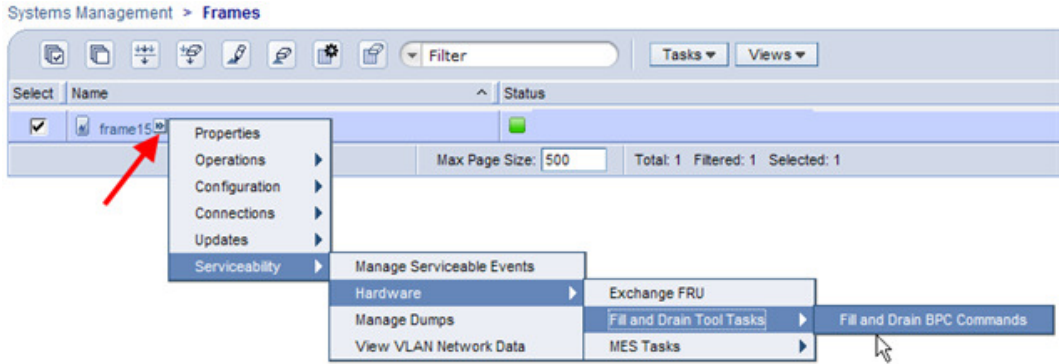

Fill and Drain Tool Command Interface will display. See below for a sample image of the interface (FDT deactivated).

Fill and Drain Tool (FDT) Command Interface - Server-78AC-100BC50029

The table below shows the FDT Port locations that can communicate with the Fill and Drain Tool. Select the port to which the Fill and Drain Tool is connected. Use the buttons to drive commands to the Fill and Drain Tool connected to a port.

FDT Port Locations:

Select	Location Code	Description
<input type="radio"/>	78AC-100*BC50029-P7-C1	Lower BPC Port T10
<input type="radio"/>	78AC-100*BC50029-P8-C1	Upper BPC Port T10

Activate FDT Deactivate FDT
Get FDT Status Decode Error Status
Fill FDT Drain FDT
Start Water Pump Reset FDT Start Air Pump
Pressure Test Calibration Component Pressure Test

Launch WCU Commands
WCU Tank Air Purge

Exit Help

12. Select the BPC port that the FDT was plugged into in **Step 6** from the **FDT Port Locations:** list.

13. *Click* the **Activate FDT** button.

- If the Activate FDT command is successful – OK. **Wait 30 seconds and continue to next step.**
- If the **Activate FDT** command fails – action required.

Click the **Deactivate FDT** button.

Wait 2 minutes and repeat **Step 13**. If the **Activate** command fails again, contact next level of support.

14. *Click* the **Get FDT Status** button.

- If the **Get FDT Status** command is successful – OK.

See below for a sample status (does not reflect expected state)

- If the **Get FDT Status** command fails – action required.

Repeat **Step 14**. If the **Get FDT Status** command fails again, contact next level of support.

Power775 Bulk Power Distributor (BPD) Fill and Drain Tool Procedures:
 ---- FDT Tank Drain Procedure ----

Fill and Drain Tool (FDT) Command Interface - Server-78AC-100BC50029

The table below shows the FDT Port locations that can communicate with the Fill and Drain Tool. Select the port to which the Fill and Drain Tool is connected. Use the buttons to drive commands to the Fill and Drain Tool connected to a port.

FDT Port Locations:

Select	Location Code	Description
<input checked="" type="radio"/>	78AC-100*BC50029-P7-C1	Lower BPC Port T10
<input type="radio"/>	78AC-100*BC50029-P8-C1	Upper BPC Port T10

FDT Power/Comm: GOOD
 Frame Attached: IBM Power7 775
 MDA-FD RL: 45D
 Error Status: WARNING
 Tank Level: Full
 Air Pump: Off
 Water Pump: DISABLED
 Tool Mode: Ready
 Pressure Test Calibration: Incomplete
 Component Pressure Test: Incomplete

Sample FDT Status

15. Review the FDT status screen and ensure the following status items are OK:

Status Item	State	Action
-------------	-------	--------

- **Tool Mode:** **Ready** – OK. Check next Status item.
- **Error Status:** **NONE** – OK. Check next Status item.

WARNING – *click* the **Decode Error Status** button, record the information returned and check Tank Level.

CRITICAL – *click* the **Decode Error Status** button, record the information returned and contact next level of support.

Power775 Bulk Power Distributor (BPD) Fill and Drain Tool Procedures:
---- FDT Tank Drain Procedure ----

- **Tank Level:** **Full, Upper Half, or Lower Half** – OK.
Note tank level, and proceed to next step.
Empty – FDT cannot be drained.
Exit procedure.

16. Locate an empty system water container.

Transport the container to the location of the FDT.

Do not place the container between the FDT and the open frame.

NOTE: Use an empty system water container **only**. If a non-empty system water container is used, water will overflow out of the container.

IBM PN **45D2124** (U.S.), **45D2129** (non-U.S.).

CAUTION: The water-based coolant solution may contain an additive intended to inhibit corrosion (or provide other functions). The solution may cause irritation to the skin or eyes. Avoid direct contact with the solution. Employ appropriate Personal Protective Equipment when performing operations involving the coolant or which may potentially expose you to the coolant. Refer to the MSDS for more information. (C037)



CAUTION: Protective eyewear is needed for the procedure. (L011)



CAUTION: Chemical resistant gloves are needed for this procedure. (L014)

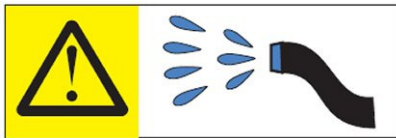

DANGER: Risk of electric shock due to water or a water solution which is present in this product. Avoid working on or near energized equipment with wet hands or when spilled water is present. (L016)

The system water is treated and must not be poured down a sink or on the ground.

Power775 Bulk Power Distributor (BPD) Fill and Drain Tool Procedures:
---- FDT Tank Drain Procedure ----

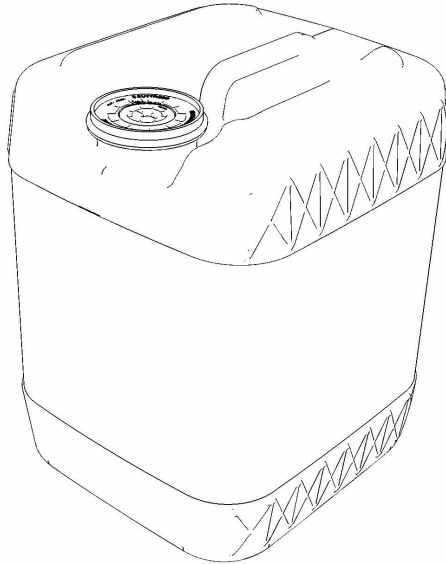

17. Remove the inner cap from the white system water container insert.
Unthread inner cap counter-clockwise with a large screwdriver.

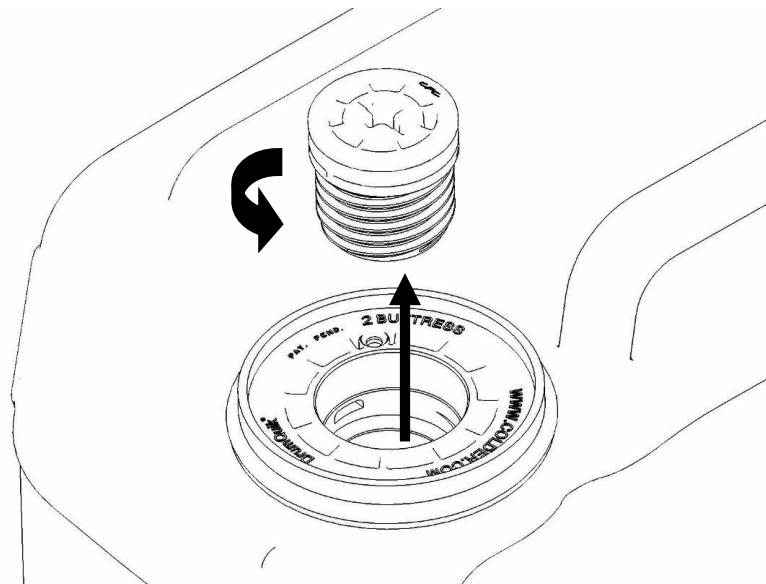

18. Remove transfer hose assembly **THA** from the upper tool storage compartment.
19. Insert large white threaded insert of **THA** into the system water container.
Turn clockwise until hand tight.

Power775 Bulk Power Distributor (BPD) Fill and Drain Tool Procedures:
---- FDT Tank Drain Procedure ----

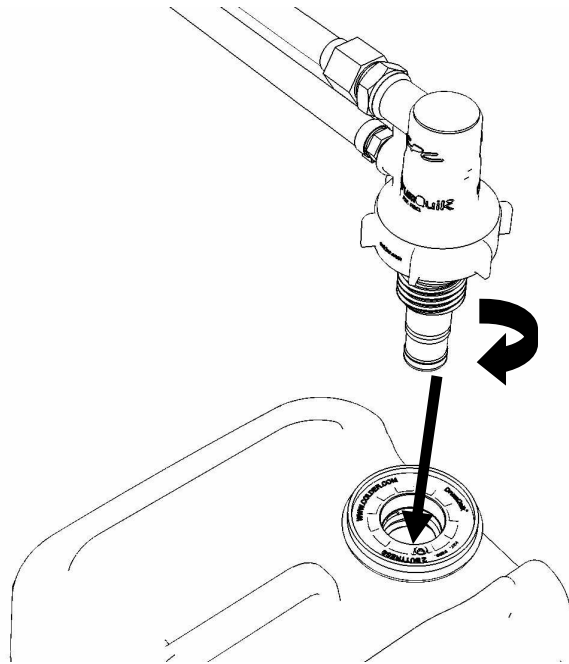

20. Connect the **Upper THA Hose** to the **TS** connection on the front panel of the FDT.

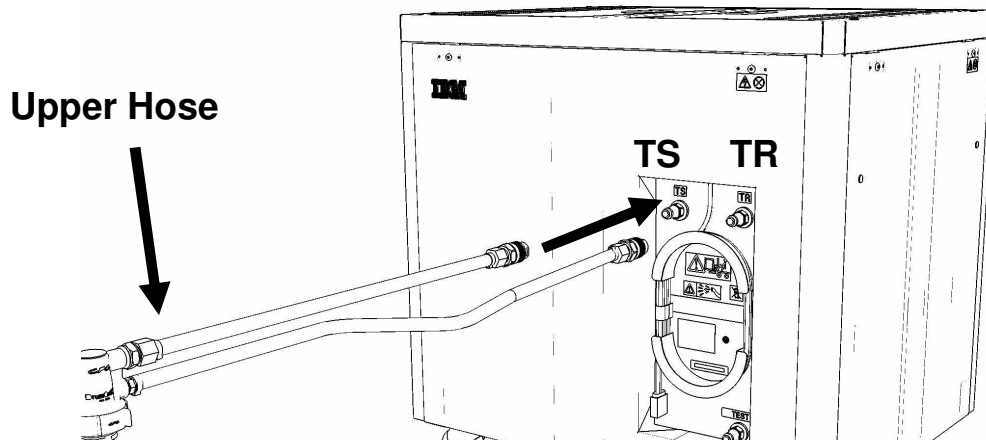

21. Connect the **Lower THA Hose** to the **TR** connection on the front panel of the FDT.

Power775 Bulk Power Distributor (BPD) Fill and Drain Tool Procedures:
---- FDT Tank Drain Procedure ----

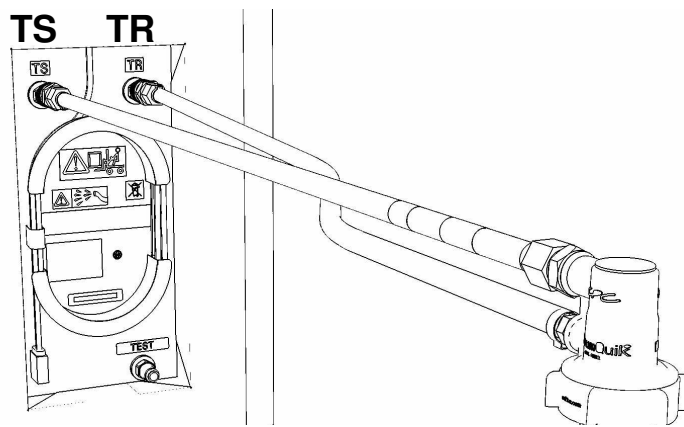
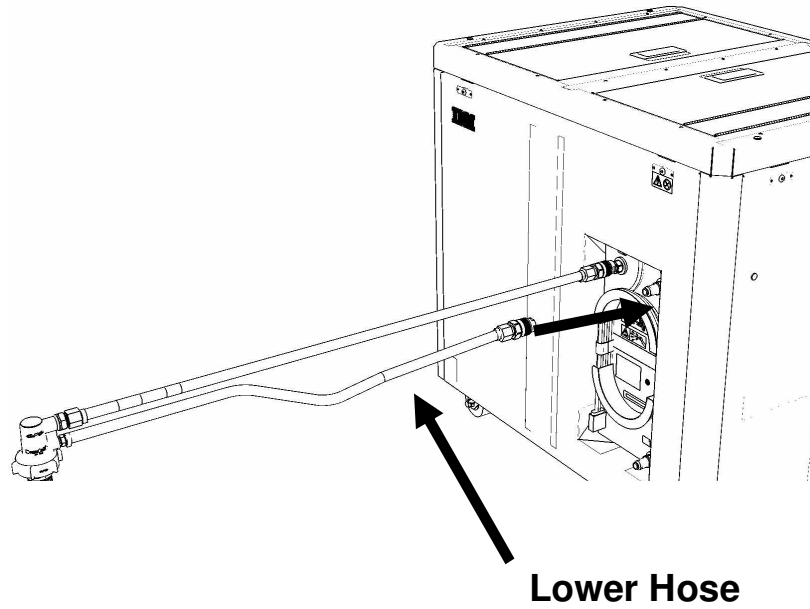

22. Ensure all water connections are made properly and securely.

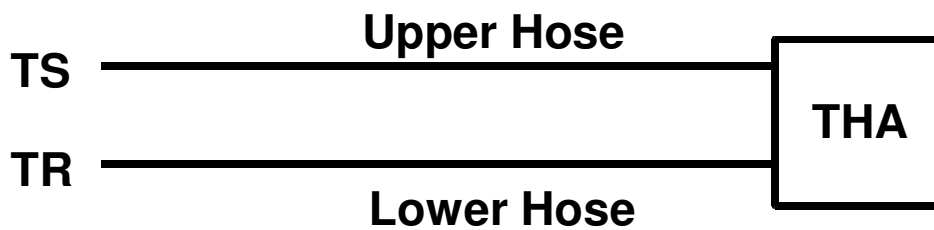

23. On the FDT panel, *click* the **Drain FDT** button.

The **Get FDT Status** button may be *clicked* to examine FDT status.

NOTE: *The water pump will shut off after 1 minute, 40 seconds of run time.*

CAUTION: **This unit must not be left running unattended, service personnel should always be overseeing the process. (C038)**

24. Verify that the container feels full of water after FDT drain.

Container will weigh approximately 35 lbs. (16 kg) when full.

- If container feels full, proceed to **Step 25**.
- If container feels empty, repeat **Step 20** and continue with procedure.
To prevent overflow, only repeat if the system water container is **still empty**.

25. Click the Get FDT Status button and ensure the following status items are OK:

<u>Status Item</u>	<u>State</u>	<u>Action</u>
• Tool mode:	Ready – OK. Check next Status item. FDT Drain Mode – water pump still running. Wait 30 seconds and repeat Step 25 .	
• Error Status:	NONE – OK. Check next Status item. WARNING – <i>click</i> the Decode Error Status button, record information returned and proceed to next step. CRITICAL – <i>click</i> the Decode Error Status button, record information returned and contact next level of support.	
• Tank Level:	Repeat Step 16 to Step 25 (with additional empty container) until desired level is reached. If tank level does not fall, repeat Step 16 through Step 25 . If tank level does not decrease after repeat, contact next level of support. To prevent overflow, only repeat if the system water container is still empty .	

Power775 Bulk Power Distributor (BPD) Fill and Drain Tool Procedures:
---- FDT Tank Drain Procedure ----

26. Disconnect the **Lower THA Hose** from the **TR** connection on the front panel of the FDT.

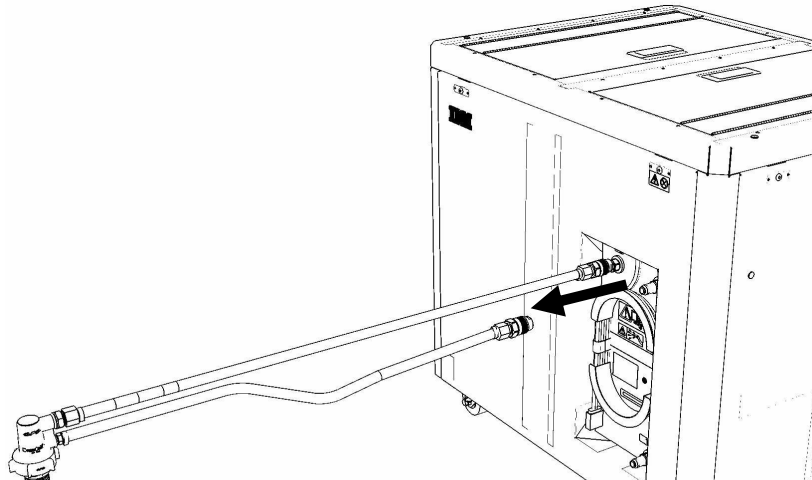

27. Disconnect the **Upper THA Hose** from the **TS** connection on the front panel of the FDT.

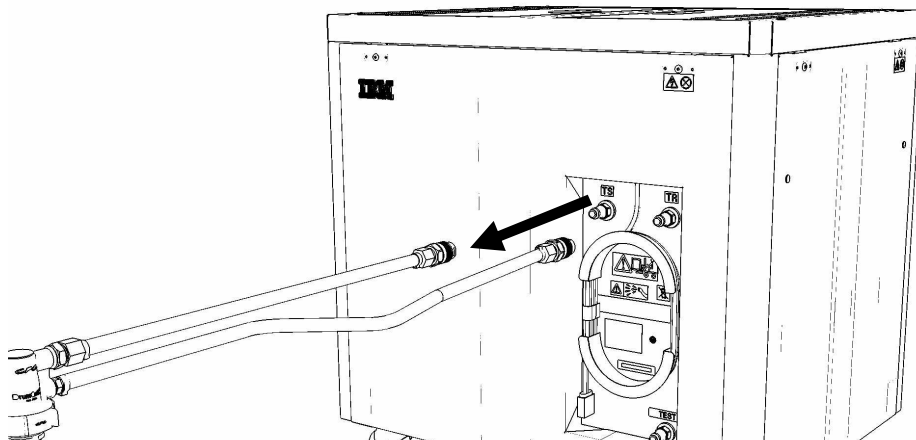

Power775 Bulk Power Distributor (BPD) Fill and Drain Tool Procedures:
---- FDT Tank Drain Procedure ----

28. Remove large white threaded insert of **THA** from the system water container.
Turn **slowly** counterclockwise until removed.
Some residual pressure may remain on the system water container

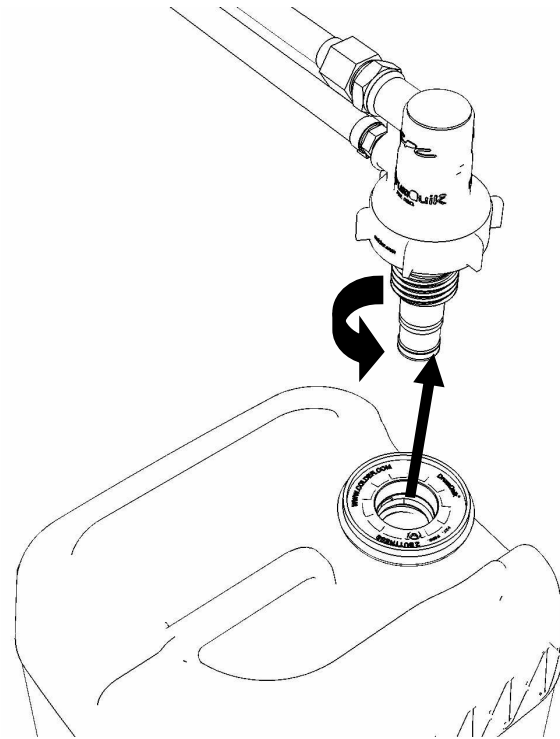

29. Replace the inner cap into the white system water container insert.
Turn inner cap clockwise with a large screwdriver.

Power775 Bulk Power Distributor (BPD) Fill and Drain Tool Procedures:
---- FDT Tank Drain Procedure ----

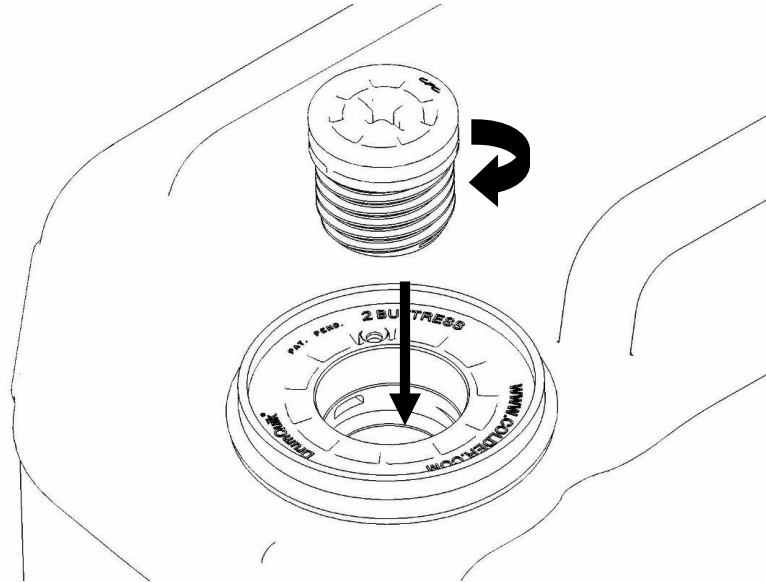

30. Place all hose assemblies and adapters in their appropriate locations within the FDT storage enclosure.

31. Determine whether the FDT will be used for another procedure:

- If the FDT will be used for another procedure, leave tool activated and go to that procedure now; skip the remaining steps of this procedure.
- If the FDT requires no further use - proceed to the next step.

32. Click the **Deactivate FDT** button.

- If the **Deactivate FDT** command is successful – OK. Proceed to next step.
- If the **Deactivate FDT** command fails– action required.

Repeat **Deactivate FDT**. If the **Deactivate FDT** command fails again, contact next level of support.

33. Disconnect FDT UPIC power cable from port T10 of BPC used.

Wrap the UPIC cable in appropriate cable storage location on FDT.

34. If this procedure was referenced from another procedure, return to parent procedure.

5.4 End of Power775 FDT Tank Drain Procedure

6 POWER775 FILL AND DRAIN TOOL (FDT) TANK FILL PROCEDURE

6.1 Safety Notices

Read "Safety Notices" available from InfoCenter:

<http://publib.boulder.ibm.com/infocenter/powersys/v3r1m5/topic/p7hdx/G229-9054.pdf>

The following cautions apply to all Power775 service procedures:

CAUTION:

Energy hazard present and Shorting might result in system outage and possible physical injury. Remove all metallic jewelry before servicing. (C001)

CAUTION:

The doors and covers to the product are to be closed at all times except for service by trained service personnel. All covers must be replaced and doors locked at the conclusion of the service operation. (C013)

CAUTION:

Servicing of this product or unit is to be performed by trained service personnel only. (C032)

The following notices specifically pertain to this Power775 service procedure.

CAUTION: The water-based coolant solution may contain an additive intended to inhibit corrosion (or provide other functions). The solution may cause irritation to the skin or eyes. Avoid direct contact with the solution. Employ appropriate Personal Protective Equipment when performing operations involving the coolant or which may potentially expose you to the coolant. Refer to the MSDS for more information. (C037)

CAUTION: This unit must not be left running unattended, service personnel should always be overseeing the process. (C038)



DANGER: Hazardous voltage present. Voltages present constitute a shock hazard, which can cause severe injury or death. (L004)



CAUTION: Protective eyewear is needed for the procedure. (L011)

Power775 Bulk Power Distributor (BPD) Fill and Drain Tool Procedures:
---- FDT Tank Fill Procedure ----



DANGER: Heavy equipment—personal injury or equipment damage might result if mishandled. (L013)



CAUTION: Chemical resistant gloves are needed for this procedure. (L014)

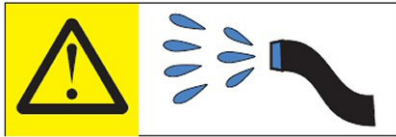

DANGER: Risk of electric shock due to water or a water solution which is present in this product. Avoid working on or near energized equipment with wet hands or when spilled water is present. (L016)

6.2 Background:

This document contains the procedure for filling an **IBM Power 775** Fill and Drain Tool (FDT) tank (internal reservoir).

The FDT is used to transfer water into and out of various components of the **IBM Power 775** system. When a system component or the entire system is filled, the water will be transferred from the tank (internal reservoir) within the FDT to the component or system. During fill operations, the FDT tank may become empty, and if so, will need to be periodically filled using the supplied system water containers. Individual system water containers treated with a corrosion inhibitor are shipped with the system. The FDT Tank Fill Procedure instructs the user to properly transfer water out of a full system water container into the FDT Tank.

During system or component filling operations, if the FDT senses that the internal reservoir has become empty, it will terminate any running fill routine, as well as prevent any further fill routines from being executed. This may occur during a system or component fill procedure; if so, the system or component fill procedure must be paused, and this FDT Tank Fill Procedure must be completed before system/component filling can resume.

The system water is treated and must not be poured down a sink or on the ground.

Reference Information:

IBM Power 775 FDT P/N:	45D6928
IBM System Water Container P/N:	45D2124 (U.S.), 45D2129 (non-U.S.)
Hose assemblies/adapters required:	THA (45D8563)

Approximate FDT internal water volume: 32 L

Expected filling time for one (1) system water container: 1 min, 30 s

NOTE: *Some steps in this procedure may be redundant due to other service operations being completed prior to this procedure. If a step has already been completed, verify that the step has been completed properly and proceed to the next step.*

6.3 Procedure:

NOTE: If you already have the FDT powered on, proceed to **Step 14**. Otherwise, start procedure at **Step 1**.

Power775 Bulk Power Distributor (BPD) Fill and Drain Tool Procedures:
---- FDT Tank Fill Procedure ----

1. Identify the **Power 775** frame that requires service.

Verify that the system UEPO is set to **ON**, and the managing consoles (HMC and XCat) are powered on and communicating with the frame.

2. Open front and rear doors of the **Power 775** frame that requires service.

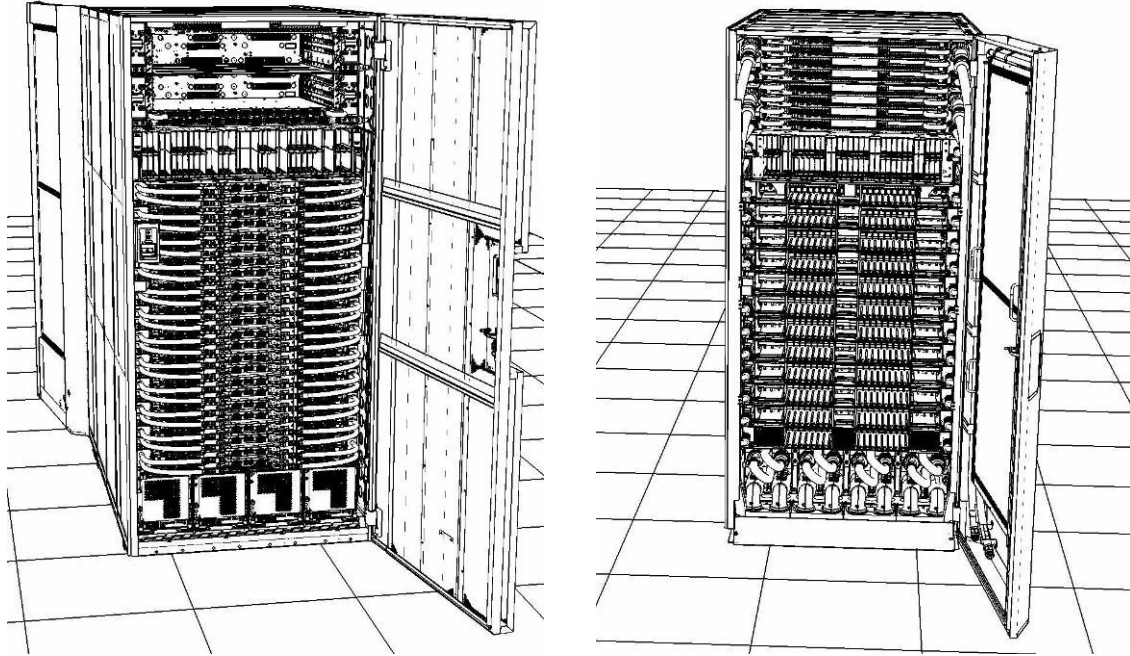

3. Bring the FDT to the front side of the **Power 775** frame that requires service.
4. Locate the panel of the FDT that contains the Universal Power and Information Cable (UPIC), as well as the **TS**, **TR**, and **TEST** water connections.

This side of the tool should be facing the front of the frame.

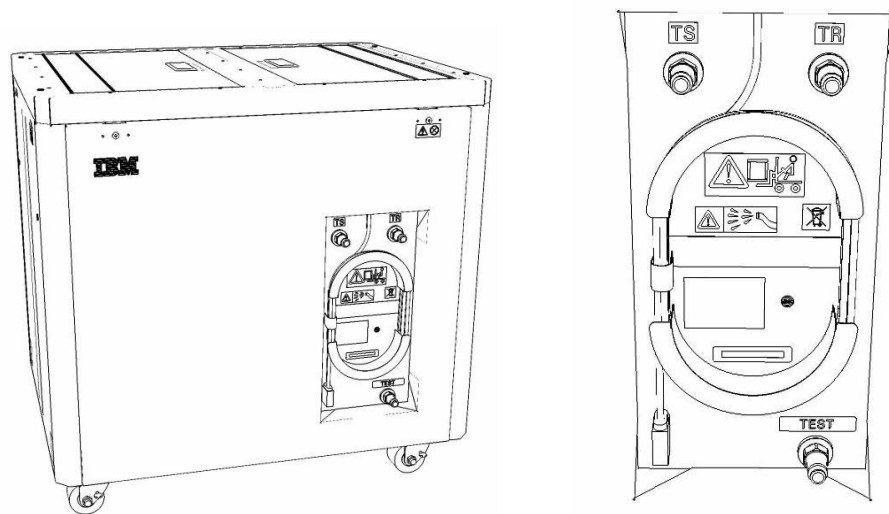

5. Unwrap the FDT UPIC cable from the storage loop on the FDT.

Power775 Bulk Power Distributor (BPD) Fill and Drain Tool Procedures:
---- FDT Tank Fill Procedure ----

6. Select BPC port for FDT

- If the lower BPA is not targeted for service, and is functional:
Plug the FDT UPIC cable into **port T10 of the lower BPC.**
- If the lower BPA is targeted for service, or is not functional:
Plug the FDT UPIC cable into **port T10 of the upper BPC.**

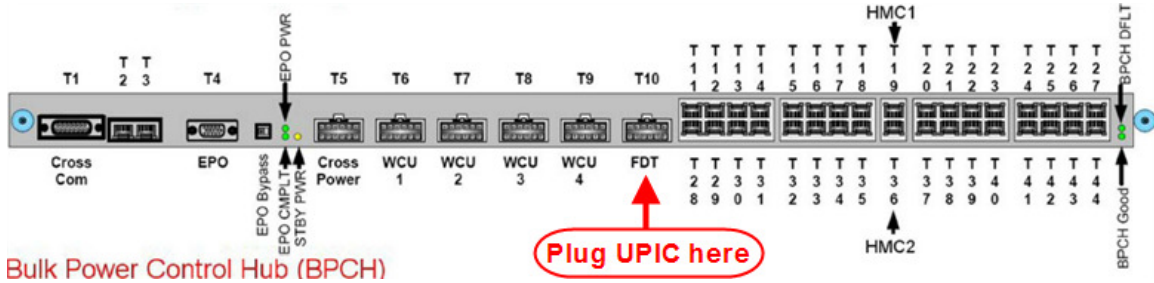

7. Login to the HMC with the User ID `hscroot`.

Use the HMC that is connected to the BPA where the FDT is plugged.

8. From the HMC left Navigation menu, expand **Systems Management** then select **Frames**.

Verify frame serial number for the frame to be serviced.

9. In the **Frames** view on the HMC, place a checkmark in the **Select** column for the frame to be serviced.

10. Verify that the frame **Status** is **Rack Standby/Rack Standby** or **Standby/Standby**.

- If frame **Status** reads **Rack Standby/Rack Standby** or **Standby/Standby** – OK.

Continue to next step.

- If frame **Status** does not read **Rack Standby/Rack Standby** or **Standby/Standby** – action required. Contact next level of support.

11. From the **Task** menu on the HMC, *select* **Serviceability** > **Hardware** > **Fill and Drain Tool Tasks** > **Fill and Drain Command Interface**

**Power775 Bulk Power Distributor (BPD) Fill and Drain Tool Procedures:
---- FDT Tank Fill Procedure ----**

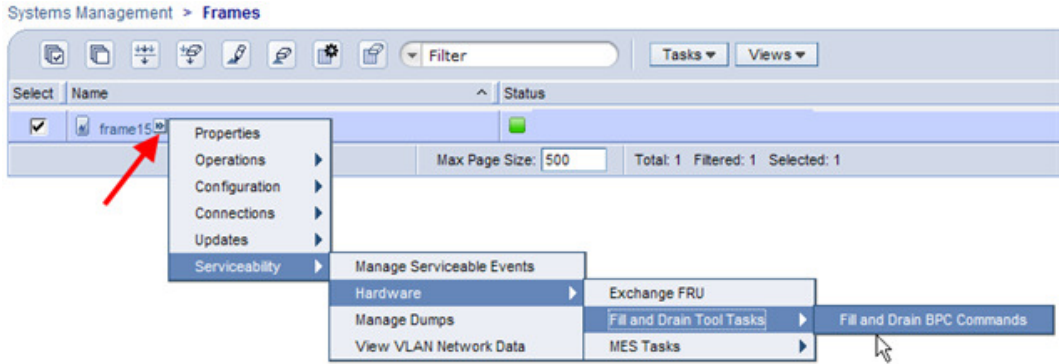

Fill and Drain Tool Command Interface will display. See below for a sample image of the interface (FDT deactivated).

Fill and Drain Tool (FDT) Command Interface - Server-78AC-100BC50029

The table below shows the FDT Port locations that can communicate with the Fill and Drain Tool. Select the port to which the Fill and Drain Tool is connected. Use the buttons to drive commands to the Fill and Drain Tool connected to a port.

FDT Port Locations:

Select	Location Code	Description
<input type="radio"/>	78AC-100*BC50029-P7-C1	Lower BPC Port T10
<input type="radio"/>	78AC-100*BC50029-P8-C1	Upper BPC Port T10

Activate FDT Deactivate FDT

Get FDT Status Decode Error Status

Fill FDT Drain FDT

Start Water Pump Reset FDT Start Air Pump

Pressure Test Calibration Component Pressure Test

Launch WCU Commands WCU Tank Air Purge

Exit Help

12. Select the BPC port that the FDT was plugged into in **Step 6** from the **FDT Port Locations:** list.

13. *Click* the **Activate FDT** button.

- If the Activate FDT command is successful – OK. **Wait 30 seconds and continue to next step.**
- If the **Activate FDT** command fails – action required.

Click the **Deactivate FDT** button.

Wait 2 minutes and repeat **Step 13**. If the **Activate** command fails again, contact next level of support.

14. *Click* the **Get FDT Status** button.

- If the **Get FDT Status** command is successful – OK.
See below for a sample status (does not reflect expected state)
- If the **Get FDT Status** command fails – action required.

Repeat **Step 14**. If the **Get FDT Status** command fails again, contact next level of support.

Power775 Bulk Power Distributor (BPD) Fill and Drain Tool Procedures:
 ---- FDT Tank Fill Procedure ----

Fill and Drain Tool (FDT) Command Interface - Server-78AC-100BC50029

The table below shows the FDT Port locations that can communicate with the Fill and Drain Tool. Select the port to which the Fill and Drain Tool is connected. Use the buttons to drive commands to the Fill and Drain Tool connected to a port.

FDT Port Locations:

Select	Location Code	Description
<input checked="" type="radio"/>	78AC-100*BC50029-P7-C1	Lower BPC Port T10
<input type="radio"/>	78AC-100*BC50029-P8-C1	Upper BPC Port T10

FDT Power/Comm: GOOD
 Frame Attached: IBM Power7 775
 MDA-FD RL: 45D
 Error Status: WARNING
 Tank Level: Full
 Air Pump: Off
 Water Pump: DISABLED
 Tool Mode: Ready
 Pressure Test Calibration: Incomplete
 Component Pressure Test: Incomplete

Sample FDT Status

15. Review the FDT status screen and ensure the following status items are OK:

Status Item	State	Action
-------------	-------	--------

- **Tool Mode:** **Ready** – OK. Check next Status item.
- **Error Status:** **NONE** – OK. Check next Status item.

WARNING – *click* the **Decode Error Status** button, record the information returned and check Tank Level.

Power775 Bulk Power Distributor (BPD) Fill and Drain Tool Procedures:
---- FDT Tank Fill Procedure ----

CRITICAL – *click* the **Decode Error Status** button, record the information returned and contact next level of support.

- **Tank Level: Lower Half or Empty** – OK.

Note tank level, and proceed to next step.

Upper Half or Full – FDT should not be filled.

Exit procedure.

16. Locate a full system water container.

Transport the container to the location of the FDT.

Do not place the container between the FDT and the open frame.

NOTE: *Use of a non-full system water container will result in repeated FDT filling operations.*

IBM PN **45D2124** (U.S.), **45D2129** (non-U.S.).

CAUTION: The water-based coolant solution may contain an additive intended to inhibit corrosion (or provide other functions). The solution may cause irritation to the skin or eyes. Avoid direct contact with the solution. Employ appropriate Personal Protective Equipment when performing operations involving the coolant or which may potentially expose you to the coolant. Refer to the MSDS for more information. (C037)



CAUTION: Protective eyewear is needed for the procedure. (L011)



CAUTION: Chemical resistant gloves are needed for this procedure. (L014)

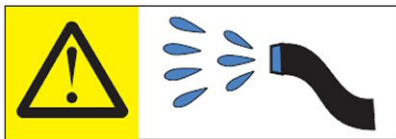

DANGER: Risk of electric shock due to water or a water solution which is present in this product. Avoid working on or near energized equipment with wet hands or when spilled water is present. (L016)

The system water is treated and must not be poured down a sink or on the ground.

Power775 Bulk Power Distributor (BPD) Fill and Drain Tool Procedures:
---- FDT Tank Fill Procedure ----

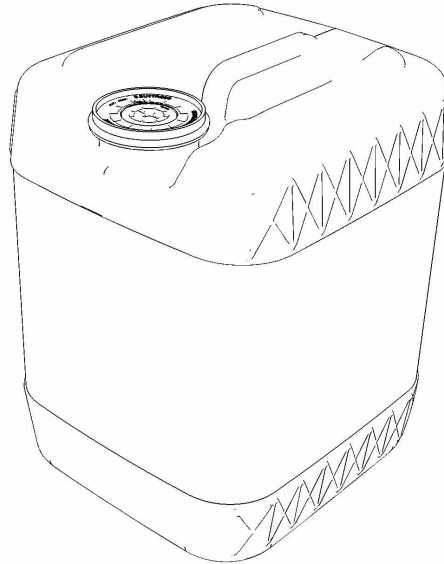

17. Remove the inner cap from the white system water container insert.
Unthread inner cap counter-clockwise with a large screwdriver.

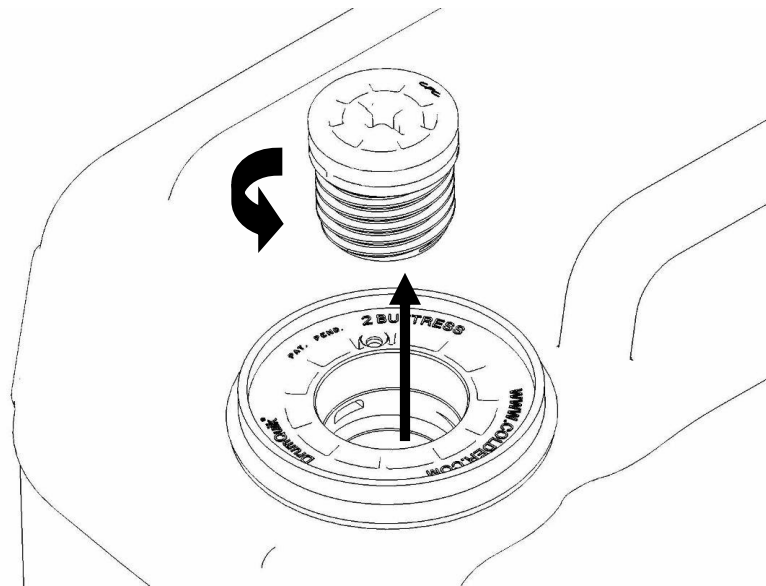

18. Remove transfer hose assembly **THA** from the upper tool storage compartment.

Power775 Bulk Power Distributor (BPD) Fill and Drain Tool Procedures:
---- FDT Tank Fill Procedure ----

19. Insert large white threaded insert of **THA** into the system water container.
Turn clockwise until hand tight.

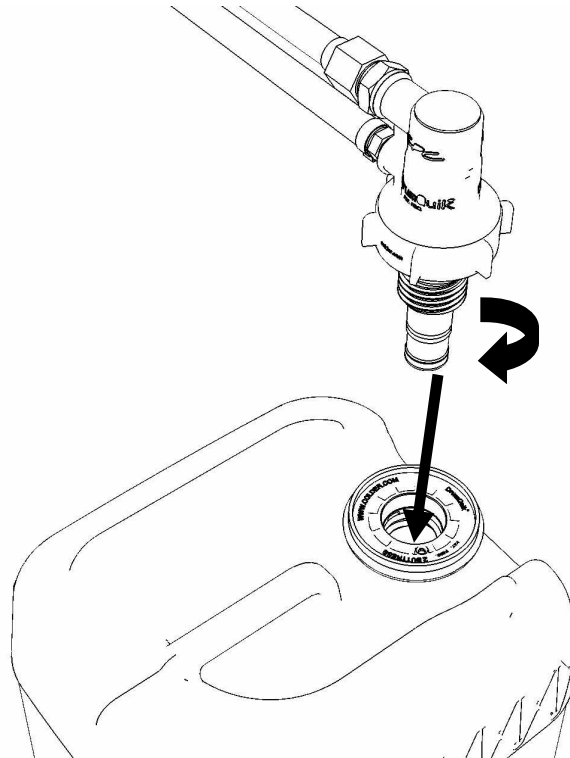

20. Connect the **Lower THA Hose** to the **TS** connection on the front panel of the FDT.

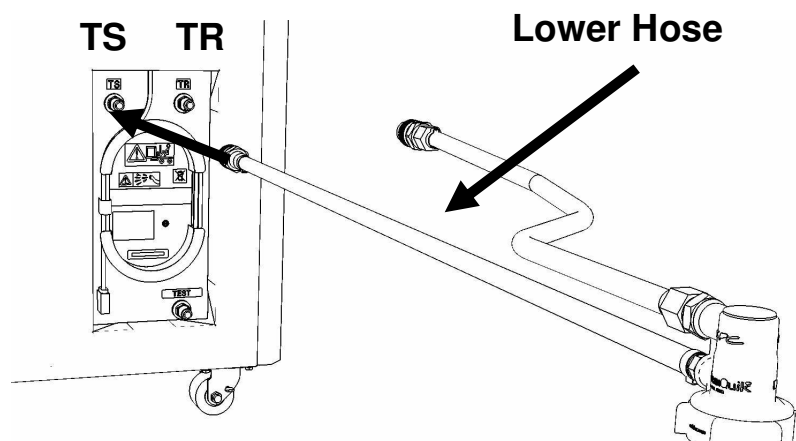

Power775 Bulk Power Distributor (BPD) Fill and Drain Tool Procedures:
---- FDT Tank Fill Procedure ----

21. Connect the **Upper THA Hose** to the **TR** connection on the front panel of the FDT.

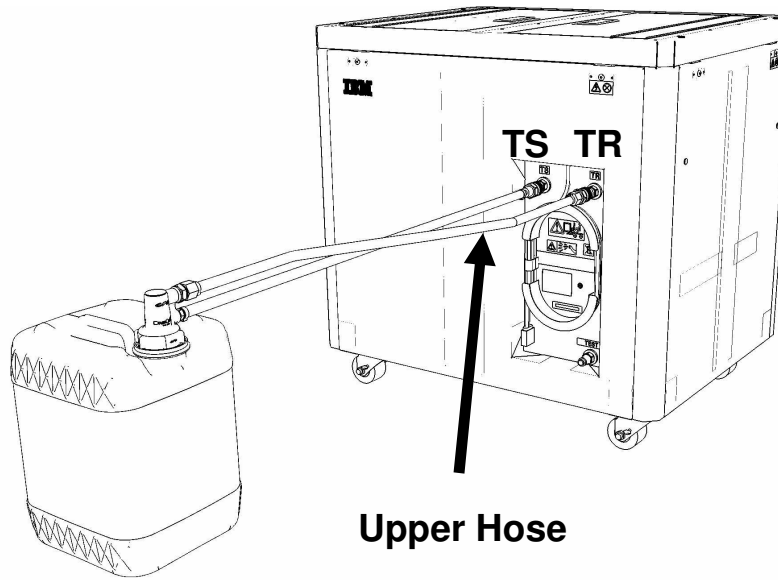

22. Ensure all water connections are made properly and securely.

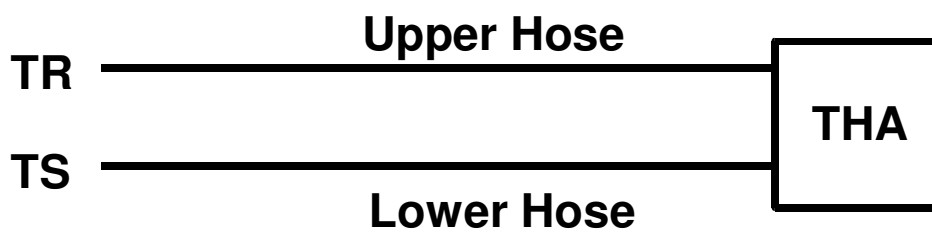

23. On the FDT panel, *click* the **Fill FDT** button.

The **Get FDT Status** button may be *clicked* to examine FDT status.

NOTE: *The air pump will shut off after 1 minute, 40 seconds of run time.*

CAUTION: **This unit must not be left running unattended, service personnel should always be overseeing the process. (C038)**

24. Verify that the container feels empty after FDT fill.

Container will weigh approximately 5 lbs. (2 kg) when empty.

- If container feels empty, proceed to **Step 25**.
- If container does not feel empty, repeat **Step 20** and continue with procedure.

25. Click the **Get FDT Status** button and ensure the following status items are OK:

<u>Status Item</u>	<u>State</u>	<u>Action</u>
• Tool mode:	Ready – OK. Check next Status item. FDT Fill Mode – air pump still running. Wait 30 seconds and repeat Step 25 .	
• Error Status:	NONE – OK. Check next Status item. WARNING – <i>click</i> the Decode Error Status button, record information returned and proceed to next step. CRITICAL – <i>click</i> the Decode Error Status button, record information returned and contact next level of support.	
• Tank Level:	Repeat Step 16 to Step 25 (with additional full container) until desired level is reached. If tank level does not rise, repeat Step 16 through Step 25 . If tank level does not increase after repeat, contact next level of support.	

Power775 Bulk Power Distributor (BPD) Fill and Drain Tool Procedures:
---- FDT Tank Fill Procedure ----

26. Disconnect the **Lower THA Hose** from the **TS** connection on the front panel of the FDT.
27. Disconnect the **Upper THA Hose** from the **TR** connection on the front panel of the FDT.

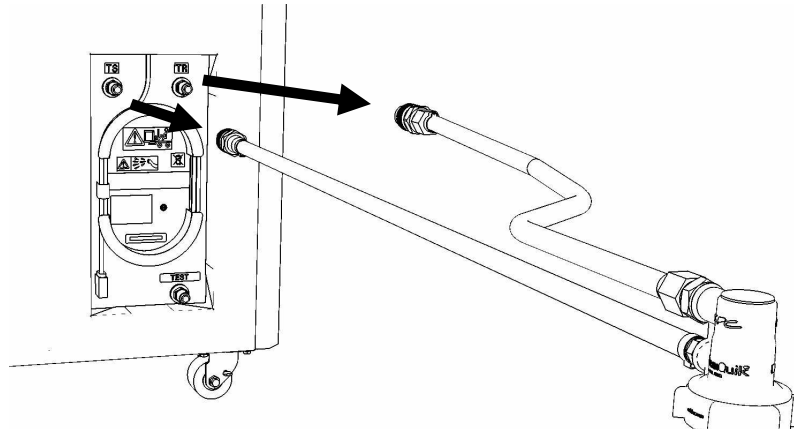

28. Remove large white threaded insert of **THA** from the system water container.
Turn **slowly** counterclockwise until removed.
Some residual pressure may remain on the system water container

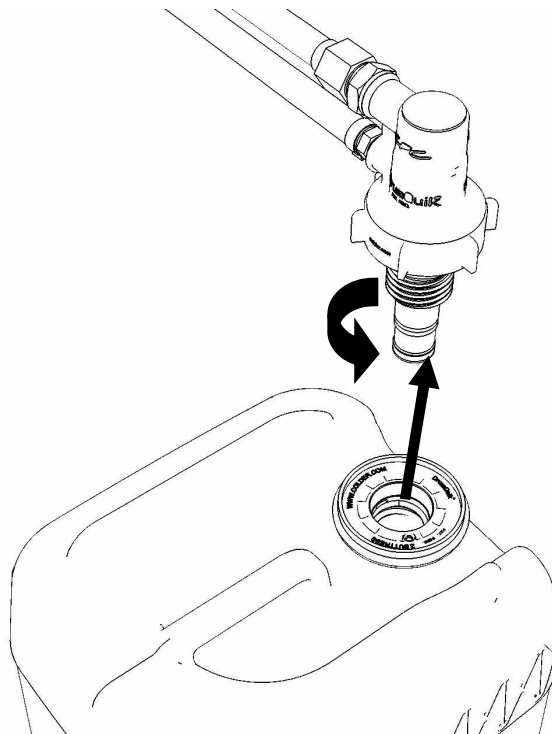

29. Replace the inner cap into the white system water container insert.
Turn inner cap clockwise with a large screwdriver.

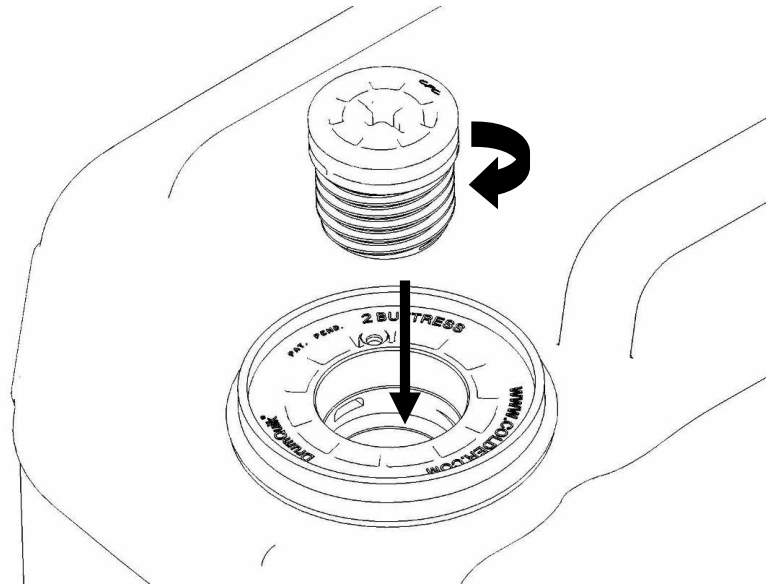

30. Place all hose assemblies and adapters in their appropriate locations within the FDT storage enclosure.
31. Determine whether the FDT will be used for another procedure:
- If the FDT will be used for another procedure, leave tool activated and go to that procedure now; skip the remaining steps of this procedure.
 - If the FDT requires no further use - proceed to the next step.
32. Click the **Deactivate FDT** button.
- If the **Deactivate FDT** command is successful – OK. Proceed to next step.
 - If the **Deactivate FDT** command fails– action required.
Repeat **Deactivate FDT**. If the **Deactivate FDT** command fails again, contact next level of support.
33. Disconnect FDT UPIC power cable from port T10 of BPC used.
Wrap the UPIC cable in appropriate cable storage location on FDT.
34. If this procedure was referenced from another procedure, return to parent procedure.

6.4 End of Power775 FDT Tank Fill Procedure

7 POWER775 FILL AND DRAIN TOOL (FDT) PRESSURE TEST CALIBRATION PROCEDURE

7.1 Safety Notices

Read "Safety Notices" available from InfoCenter:

<http://publib.boulder.ibm.com/infocenter/powersys/v3r1m5/topic/p7hdx/G229-9054.pdf>

The following cautions apply to all Power775 service procedures:

CAUTION:

Energy hazard present and Shorting might result in system outage and possible physical injury. Remove all metallic jewelry before servicing. (C001)

CAUTION:

The doors and covers to the product are to be closed at all times except for service by trained service personnel. All covers must be replaced and doors locked at the conclusion of the service operation. (C013)

CAUTION:

Servicing of this product or unit is to be performed by trained service personnel only. (C032)

The following notices specifically pertain to this Power775 service procedure.

CAUTION: The water-based coolant solution may contain an additive intended to inhibit corrosion (or provide other functions). The solution may cause irritation to the skin or eyes. Avoid direct contact with the solution. Employ appropriate Personal Protective Equipment when performing operations involving the coolant or which may potentially expose you to the coolant. Refer to the MSDS for more information. (C037)

CAUTION: This unit must not be left running unattended, service personnel should always be overseeing the process. (C038)



DANGER: Hazardous voltage present. Voltages present constitute a shock hazard, which can cause severe injury or death. (L004)



CAUTION: Protective eyewear is needed for the procedure. (L011)

Power775 Bulk Power Distributor (BPD) Fill and Drain Tool Procedures:
---- FDT Pressure Test Calibration Procedure ----



DANGER: Heavy equipment—personal injury or equipment damage might result if mishandled. (L013)



CAUTION: Chemical resistant gloves are needed for this procedure. (L014)

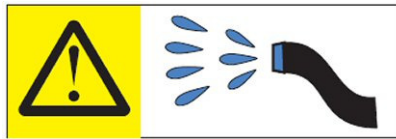

DANGER: Risk of electric shock due to water or a water solution which is present in this product. Avoid working on or near energized equipment with wet hands or when spilled water is present. (L016)

7.2 Background:

This document contains the procedure for performing an **IBM Power 775** Fill and Drain Tool (FDT) pressure test calibration procedure for an **IBM Power 775** system.

To ensure that all water cooled components in the **IBM Power 775** system are leak-free, the **IBM Power 775** Fill and Drain Tool (FDT) is equipped with air pressure testing capability. The FDT Pressure Test Calibration routine is designed as a diagnostic test to verify the integrity of the FDT air pump, associated plumbing, and hose assemblies. This procedure tests for leaks within the FDT and FDT hose assemblies, and *must* be completed before a component (FRU) pressure test or fill is executed. The results of the calibration routine are recorded within the FDT.

If the calibration passes, system and component pressure tests can be completed.

If the calibration fails, there is a functional defect in the FDT or hose assemblies. System or component pressure tests cannot be completed. System or component fills must not be completed unless pressure tests are done first to ensure there are no leaks. Upon a calibration failure, the next level of support must be contacted for FDT debug and repair.

Once the FDT has been activated, a system or component fill procedure cannot be executed unless both the Pressure Test Calibration and Component Pressure Test have passed. The water pump within the FDT will otherwise be disabled until these conditions are met.

To properly complete a pressure test, the FDT hose assemblies must be purged of water. No specific hose drain procedure is required; the Pressure Test Calibration routine will drain all required hose assemblies if they have been left full of water.

Reference Information:

IBM Power 775 FDT P/N:	45D6928
Hose assemblies/adapters required:	HA1 (45D8561)
	HA2 (45D8562)
	A3 (45D8567)

Total Pressure Test Calibration runtime: 1 min (air pump on 30 s)

NOTE: *Some steps in this procedure may be redundant due to other service operations being completed prior to this procedure. If a step has already been completed, verify that the step has been completed properly and proceed to the next step.*

7.3 Procedure:

NOTE: If you already have the FDT powered on, proceed to **Step 14**. Otherwise, start procedure at **Step 1**.

Power775 Bulk Power Distributor (BPD) Fill and Drain Tool Procedures:
---- FDT Pressure Test Calibration Procedure ----

1. Identify the **Power 775** frame that requires service.

Verify that the system UEPO is set to **ON**, and the managing consoles (HMC and XCat) are powered on and communicating with the frame.

2. Open front and rear doors of the **Power 775** frame that requires service.

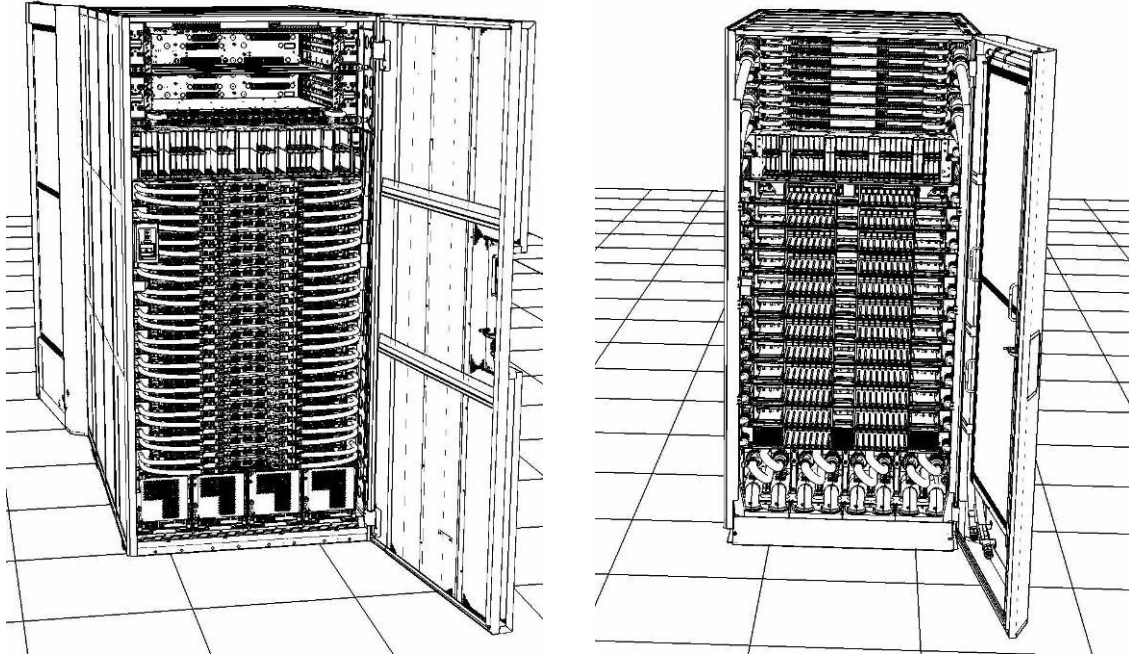

3. Bring the FDT to the front side of the **Power 775** frame that requires service.
4. Locate the panel of the FDT that contains the Universal Power and Information Cable (UPIC), as well as the **TS**, **TR**, and **TEST** water connections.

This side of the tool should be facing the front of the frame.

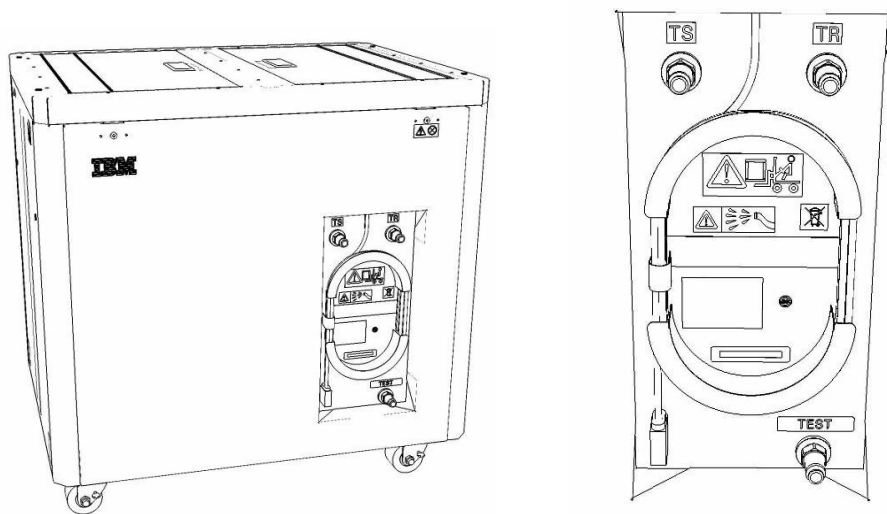

5. Unwrap the FDT UPIC cable from the storage loop on the FDT.

**Power775 Bulk Power Distributor (BPD) Fill and Drain Tool Procedures:
---- FDT Pressure Test Calibration Procedure ----**

6. Select BPC port for FDT

- If the lower BPA is not targeted for service, and is functional:
Plug the FDT UPIC cable into **port T10 of the lower BPC.**
- If the lower BPA is targeted for service, or is not functional:
Plug the FDT UPIC cable into **port T10 of the upper BPC.**

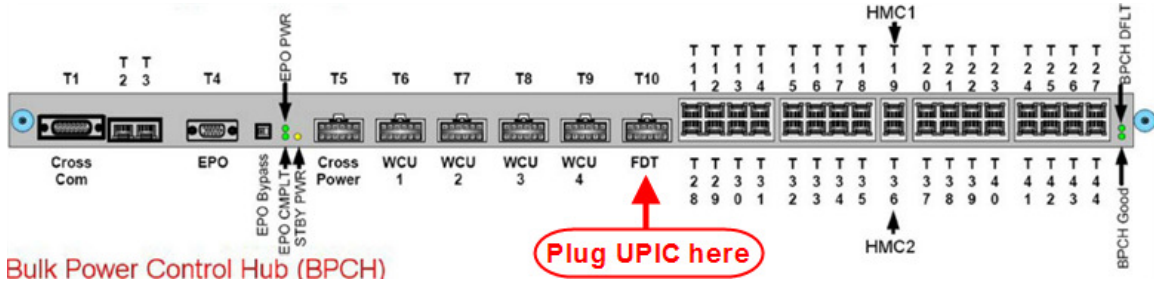

7. Login to the HMC with the User ID **hscroot**.

Use the HMC that is connected to the BPA where the FDT is plugged.

8. From the HMC left Navigation menu, expand **Systems Management** then select **Frames**.

Verify frame serial number for the frame to be serviced.

9. In the **Frames** view on the HMC, place a checkmark in the **Select** column for the frame to be serviced.

10. Verify that the frame **Status** is **Rack Standby/Rack Standby** or **Standby/Standby**.

- If frame **Status** reads **Rack Standby/Rack Standby** or **Standby/Standby** – OK.

Continue to next step.

- If frame **Status** does not read **Rack Standby/Rack Standby** or **Standby/Standby** – action required. Contact next level of support.

11. From the **Task** menu on the HMC, *select* **Serviceability** > **Hardware** > **Fill and Drain Tool Tasks** > **Fill and Drain Command Interface**

**Power775 Bulk Power Distributor (BPD) Fill and Drain Tool Procedures:
---- FDT Pressure Test Calibration Procedure ----**

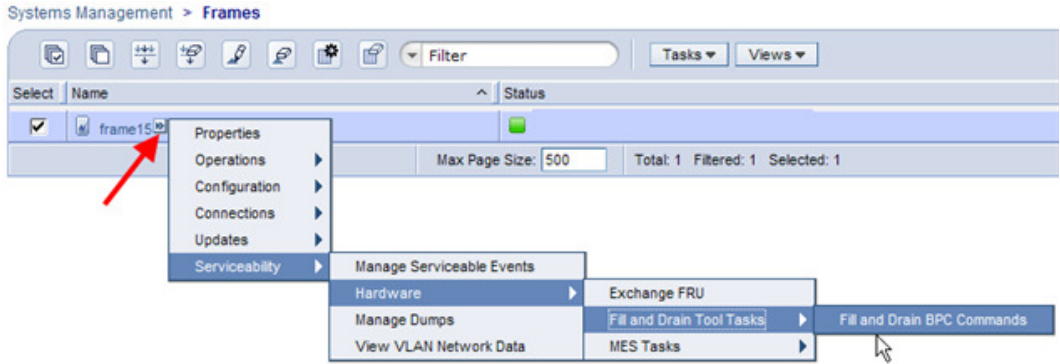

Fill and Drain Tool Command Interface will display. See below for a sample image of the interface (FDT deactivated).

Fill and Drain Tool (FDT) Command Interface - Server-78AC-100BC50029

The table below shows the FDT Port locations that can communicate with the Fill and Drain Tool. Select the port to which the Fill and Drain Tool is connected. Use the buttons to drive commands to the Fill and Drain Tool connected to a port.

FDT Port Locations:

Select	Location Code	Description
<input type="radio"/>	78AC-100*BC50029-P7-C1	Lower BPC Port T10
<input type="radio"/>	78AC-100*BC50029-P8-C1	Upper BPC Port T10

Activate FDT Deactivate FDT
Get FDT Status Decode Error Status
Fill FDT Drain FDT
Start Water Pump Reset FDT Start Air Pump
Pressure Test Calibration Component Pressure Test

Launch WCU Commands WCU Tank Air Purge

Exit Help

12. Select the BPC port that the FDT was plugged into in **Step 6** from the **FDT Port Locations:** list.

13. *Click* the **Activate FDT** button.

- If the Activate FDT command is successful – OK. **Wait 30 seconds and continue to next step.**
- If the **Activate FDT** command fails – action required.

Click the **Deactivate FDT** button.

Wait 2 minutes and repeat **Step 13**. If the **Activate** command fails again, contact next level of support.

14. *Click* the **Get FDT Status** button.

- If the **Get FDT Status** command is successful – OK.

See below for a sample status (does not reflect expected state)

- If the **Get FDT Status** command fails – action required.

Repeat **Step 14**. If the **Get FDT Status** command fails again, contact next level of support.

Power775 Bulk Power Distributor (BPD) Fill and Drain Tool Procedures:
 ---- FDT Pressure Test Calibration Procedure ----

Fill and Drain Tool (FDT) Command Interface - Server-78AC-100BC50029

The table below shows the FDT Port locations that can communicate with the Fill and Drain Tool. Select the port to which the Fill and Drain Tool is connected. Use the buttons to drive commands to the Fill and Drain Tool connected to a port.

FDT Port Locations:

Select	Location Code	Description
<input checked="" type="radio"/>	78AC-100*BC50029-P7-C1	Lower BPC Port T10
<input type="radio"/>	78AC-100*BC50029-P8-C1	Upper BPC Port T10

FDT Power/Comm: GOOD
 Frame Attached: IBM Power7 775
 MDA-FD RL: 45D
 Error Status: WARNING
 Tank Level: Full
 Air Pump: Off
 Water Pump: DISABLED
 Tool Mode: Ready
 Pressure Test Calibration: Incomplete
 Component Pressure Test: Incomplete

Sample FDT Status

15. Review the FDT status screen and ensure the following status items are OK:

Status Item	State	Action
-------------	-------	--------

- **Tool Mode:** **Ready** – OK. Check next Status item.
- **Error Status:** **NONE** – OK. Check next Status item.

WARNING – *click* the **Decode Error Status** button, record the information returned and check Tank Level.

CRITICAL – *click* the **Decode Error Status** button, record the information returned and contact next level of support.

Power775 Bulk Power Distributor (BPD) Fill and Drain Tool Procedures:
---- FDT Pressure Test Calibration Procedure ----

- **Tank Level:** **Upper Half, Lower Half or Empty** – OK. Check next Status item.
Full – action required.
Exit this procedure and perform the **Power 775 Fill and Drain Tool (FDT) Tank Drain Procedure**.
Once FDT tank level is **Upper Half, Lower Half or Empty**, return to this step and continue with procedure.
- **Pressure Test Calibration:** **Incomplete** - OK. Proceed to next step.
Pass or Fail – action required.
*Click the **Deactivate FDT** button.*
Repeat **Step 13** and continue with procedure.

16. Before proceeding, read required safety information:

CAUTION: The water-based coolant solution may contain an additive intended to inhibit corrosion (or provide other functions). The solution may cause irritation to the skin or eyes. Avoid direct contact with the solution. Employ appropriate Personal Protective Equipment when performing operations involving the coolant or which may potentially expose you to the coolant. Refer to the MSDS for more information. (C037)



CAUTION: Protective eyewear is needed for the procedure. (L011)



CAUTION: Chemical resistant gloves are needed for this procedure. (L014)

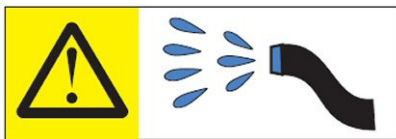

DANGER: Risk of electric shock due to water or a water solution which is present in this product. Avoid working on or near energized equipment with wet hands or when spilled water is present. (L016)

17. Remove hose assembly **HA1** from the upper tool storage compartment.

Power775 Bulk Power Distributor (BPD) Fill and Drain Tool Procedures:
---- FDT Pressure Test Calibration Procedure ----

Connect either end of hose assembly **HA1** to the **TEST** connection on the front panel of the FDT.

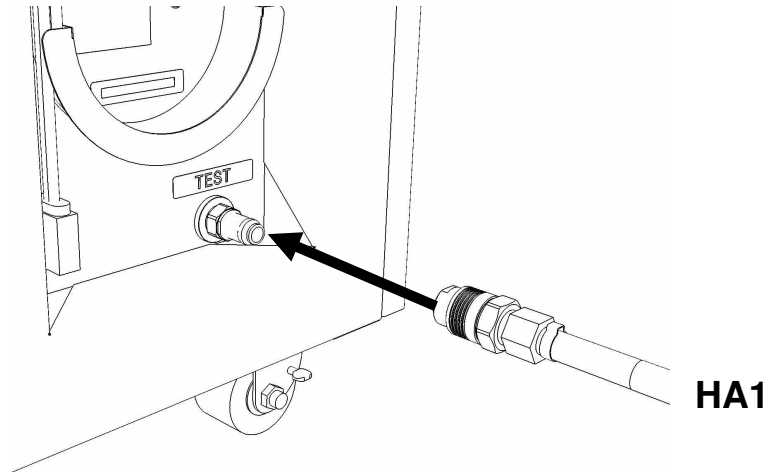

18. Remove hose assembly **HA2** from the upper tool storage compartment. Connect the end *without sight glass* to the TR connection on the FDT.

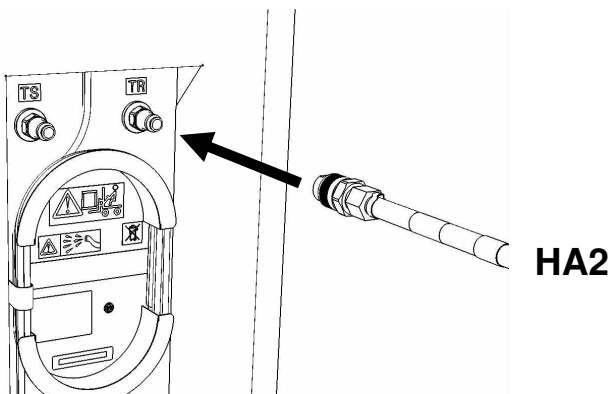

19. Remove adapter **A3** from the FDT.
Connect the free ends of **HA1** and **HA2** together via adapter **A3**.
Place excess hose on floor in front of FDT.

Power775 Bulk Power Distributor (BPD) Fill and Drain Tool Procedures:
---- FDT Pressure Test Calibration Procedure ----

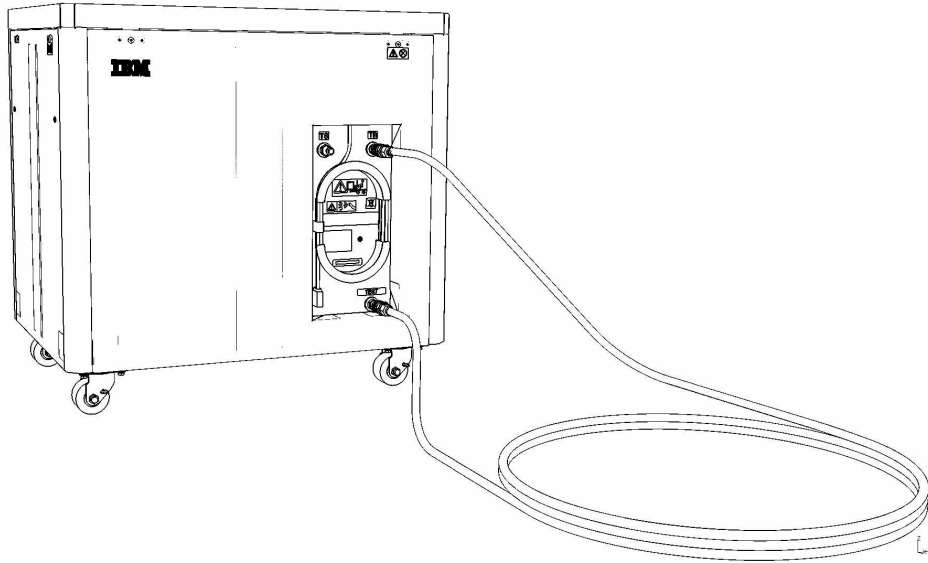

20. Ensure all water connections are made properly and securely.

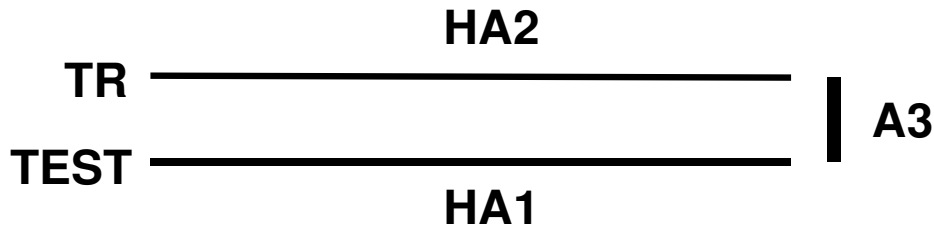

21. On the FDT panel, *click* the **Pressure Test Calibration** button.

The **Get FDT Status** button may be *clicked* to examine FDT status.

NOTE: *The pressure testing will last for 1 minute (30 seconds with air pump on)*

CAUTION: **This unit must not be left running unattended, service personnel should always be overseeing the process. (C038)**

22. *Click* the **Get FDT Status** button and review the following:

- **Tool mode:** **Ready – OK.** Check Error Status.
 Pressure Test Calibration Mode – pressure test still running.

Power775 Bulk Power Distributor (BPD) Fill and Drain Tool Procedures:
---- FDT Pressure Test Calibration Procedure ----

Wait 30 seconds and repeat **Step 22**.

- **Error Status:** **NONE** – OK. Check Pressure Test Calibration.
WARNING – *click* the **Decode Error Status** button, record information returned and proceed to next step.
CRITICAL – *click* the **Decode Error Status** button, record information returned and contact next level of support.
- **Pressure Test Calibration:** **Pass** – OK. Proceed to next step.
Fail or Incomplete – action required.
Click the **Reset FDT** button.
Repeat **Step 17** and continue with procedure.
If the test read **Fail** twice, hardware is defective. Contact next level of support.

23. The FDT Pressure Test Calibration has passed successfully.

NOTE: *If a Component Pressure Test procedure will be completed following this test, disregard Step 25 – 26. These hose connections will be the same in the component pressure test procedure.*

24. Disconnect hose assemblies **HA1** and **HA2** from adapter **A3**.

Power775 Bulk Power Distributor (BPD) Fill and Drain Tool Procedures:
---- FDT Pressure Test Calibration Procedure ----

25. Disconnect the FDT end of **HA1** from **TS** on the FDT.

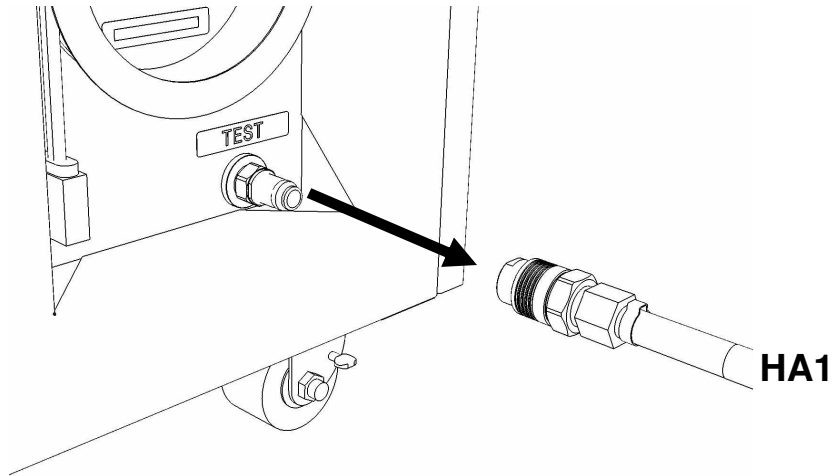

26. Disconnect the FDT end of **HA2** from **TR** on the FDT.

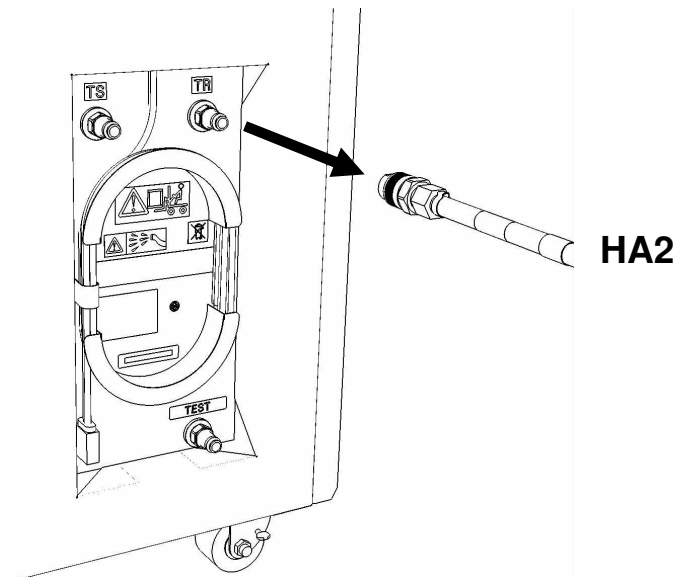

27. Place all hose assemblies and adapters in their appropriate locations within the FDT storage enclosure.

28. Determine whether the FDT will be used for another procedure:

- If the FDT will be used for another procedure, leave tool activated and go to that procedure now; skip the remaining steps of this procedure.
- If the FDT requires no further use - proceed to the next step.

29. *Click* the **Deactivate FDT** button.

- If the **Deactivate FDT** command is successful – OK. Proceed to next step.
- If the **Deactivate FDT** command fails– action required.

Repeat **Deactivate FDT**. If the **Deactivate FDT** command fails again, contact next level of support.

30. Disconnect FDT UPIC power cable from port T10 of BPC used.

Wrap the UPIC cable in appropriate cable storage location on FDT.

31. If this procedure was referenced from another procedure, return to parent procedure.

7.4 End of Power775 FDT Pressure Test Calibration Procedure

8 APPENDIX A: IBM POWER775 FDT VOLUME TABLES

8.1 IBM Power 775 Component Water Volumes

	Liters	Gallons
WCU	10.75	2.84
Supply Manifold	5.64	1.49
Return Manifold	5.64	1.49
CEC	1.74	0.46
CEC DCCA	0.07	0.02
CEC + 2 DCCAs	1.87	0.49
BPE	0.97	0.26
BPR	0.12	0.03
BPD	0.18	0.05
Disk Enclosure	0.90	0.24
RDHX	7.50	1.98
System Water Container	15.00	3.96
FDT Tank (Internal Reservoir)	32.00	8.45

Table 4 IBM Power 775 Component Water Volumes

8.2 IBM Power 775 System Water Volumes

		Number of CEC Drawers										
		2	3	4	5	6	7	8	9	10	11	12
Number of Disk Enclosures	0	46.8	48.6	50.5	63.6	65.4	67.3	69.2	82.3	84.1	86.0	87.9
	1	47.7	49.5	51.4	64.5	66.3	68.2	70.1	83.2	85.0	86.9	88.8
	2	48.6	50.4	52.3	65.4	67.2	69.1	71.0	84.1	85.9		
	3	49.5	51.3	53.2	66.3	68.1	70.0	71.9				
	4	50.4	52.2	54.1	67.2	69.0						
	5	51.3	53.1	55.0								
	6	52.2										

(Volumes in Liters)

Table 5 IBM Power 775 System Water Volume (Liters)

		Number of CEC Drawers										
		2	3	4	5	6	7	8	9	10	11	12
Number of Disk Enclosures	0	12.4	12.8	13.3	16.8	17.3	17.8	18.3	21.7	22.2	22.7	23.2
	1	12.6	13.1	13.6	17.0	17.5	18.0	18.5	22.0	22.5	23.0	23.5
	2	12.8	13.3	13.8	17.3	17.8	18.3	18.8	22.2	22.7		
	3	13.1	13.6	14.1	17.5	18.0	18.5	19.0				
	4	13.3	13.8	14.3	17.7	18.2						
	5	13.5	14.0	14.5								
	6	13.8										

(Volumes in Gallons)

Table 6 IBM Power 775 System Water Volume (Gallons)

8.3 IBM Power 775 System Water Containers per Frame

		Number of CEC Drawers										
		2	3	4	5	6	7	8	9	10	11	12
Number of Disk Enclosures	0	4	4	4	5	5	5	5	6	6	6	6
	1	4	4	4	5	5	5	5	6	6	6	6
	2	4	4	4	5	5	5	5	6	6		
	3	4	4	4	5	5	5	5				
	4	4	4	4	5	5						
	5	4	4	4								
	6	4										

Table 7 IBM Power 775 Required Number of System Water Containers per Frame

8.4 End of Appendix A: Power775 FDT Volume Tables