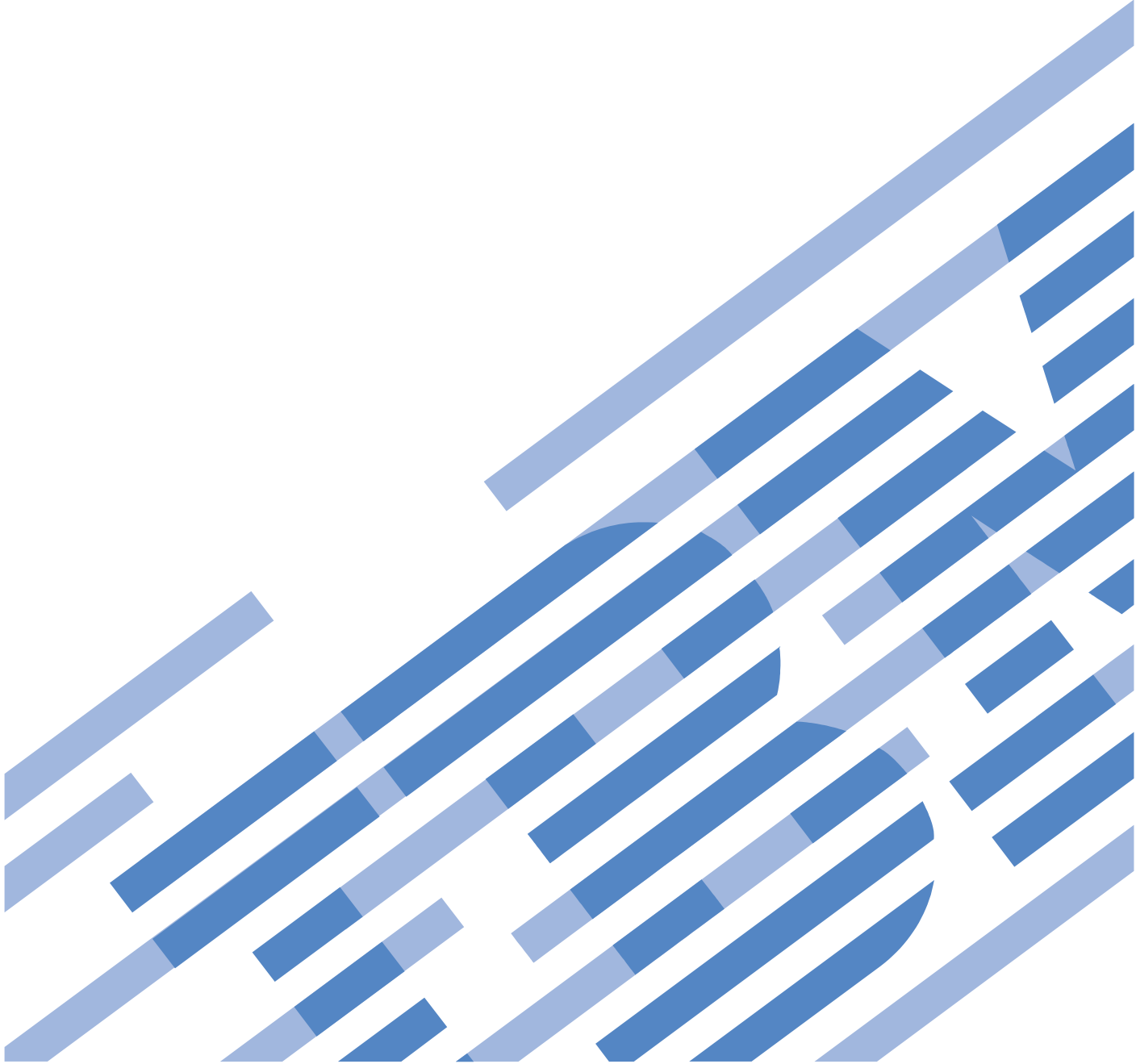


# **Power775 Bulk Power Enclosure (BPE) Service Procedure Last Modified 9/20/2012 7:49 PM**



# CONTENTS

<b>1</b>	<b>GENERAL</b> .....	<b>7</b>
1.1	RELEASE / REVISION HISTORY .....	7
1.2	WHERE TO FIND THIS DOCUMENT .....	7
1.3	REQUIRED DOCUMENTS .....	7
1.4	ACRONYMS / ABBREVIATIONS .....	8
<b>2</b>	<b>OVERVIEW</b> .....	<b>9</b>
2.1	SAFETY NOTICES .....	9
2.2	ATTENTION: FILE SYSTEM RISK STATEMENT .....	10
2.3	BPE DESCRIPTION .....	10
2.4	BACKGROUND .....	11
2.5	CONCURRENCY .....	12
2.6	BPE WEIGHT .....	12
2.7	REQUIRED SSRs AND ROLES .....	12
2.8	ESTIMATED SERVICE TIME .....	12
2.9	P7IH HAND TOOL KIT P/N 74Y0988 REQUIRED TOOLS .....	12
2.10	OVERVIEW OF PROCEDURE .....	13
<b>3</b>	<b>SERVICE PROCEDURE</b> .....	<b>14</b>
3.1	ASSESS REDUCTION IN PERFORMANCE <= CUSTOMER TASK .....	14
3.2	IDENTIFY AND REPLACE BPE <= SSR TASK .....	14
3.3	END OF POWER775 BULK POWER ENCLOSURE (BPE) SERVICE PROCEDURE .....	69
<b>4</b>	<b>APPENDIX A: POWER775 BPC FSP COMMAND LINE PROCEDURE</b> .....	<b>70</b>
4.1	PROCEDURE TO ACCESS THE BPC FSP COMMAND LINE .....	70
4.2	END OF APPENDIX A: POWER775 BPC FSP COMMAND LINE PROCEDURE .....	73
<b>5</b>	<b>APPENDIX B: POWER775 BULK POWER ENCLOSURE (BPE) PRESSURE TEST PROCEDURE WITH COMPONENTS</b> .....	<b>74</b>
5.1	SAFETY NOTICES .....	74
5.2	BACKGROUND: .....	76
5.3	PROCEDURE: .....	77
5.4	END OF APPENDIX B: POWER775 BULK POWER ENCLOSURE (BPE) PRESSURE TEST PROCEDURE WITH COMPONENTS .....	89
<b>6</b>	<b>APPENDIX C: POWER775 BULK POWER ENCLOSURE (BPE) FILL PROCEDURE</b> .....	<b>90</b>
6.1	SAFETY NOTICES .....	90
6.2	BACKGROUND: .....	92
6.3	PROCEDURE: .....	92
6.4	END OF APPENDIX C: POWER775 BULK POWER ENCLOSURE (BPE) FILL PROCEDURE .....	105
<b>7</b>	<b>APPENDIX D: POWER775 BULK POWER ENCLOSURE (BPE) DRAIN PROCEDURE</b> ..	<b>106</b>
7.1	SAFETY NOTICES .....	106
7.2	BACKGROUND: .....	108
7.3	PROCEDURE: .....	108
7.4	END OF APPENDIX D: POWER775 BULK POWER ENCLOSURE (BPE) DRAIN PROCEDURE .....	120

- 8 APPENDIX E: POWER775 FILL AND DRAIN TOOL (FDT) PRESSURE TEST CALIBRATION PROCEDURE..... 121**
- 8.1 SAFETY NOTICES..... 121
- 8.2 BACKGROUND:..... 123
- 8.3 PROCEDURE: ..... 123
- 8.4 END OF APPENDIX E: POWER775 FILL AND DRAIN TOOL (FDT) PRESSURE TEST CALIBRATION PROCEDURE..... 134
  
- 9 APPENDIX F: POWER775 FILL AND DRAIN TOOL (FDT) TANK FILL PROCEDURE . 135**
- 9.1 SAFETY NOTICES..... 135
- 9.2 BACKGROUND:..... 137
- 9.3 PROCEDURE: ..... 137
- 9.4 END OF APPENDIX F: POWER775 FILL AND DRAIN TOOL (FDT) TANK FILL PROCEDURE ..... 149
  
- 10 APPENDIX G: POWER775 FILL AND DRAIN TOOL (FDT) TANK DRAIN PROCEDURE ..... 150**
- 10.1 SAFETY NOTICES..... 150
- 10.2 BACKGROUND:..... 152
- 10.3 PROCEDURE: ..... 152
- 10.4 END OF APPENDIX G: POWER775 FILL AND DRAIN TOOL (FDT) TANK DRAIN PROCEDURE ..... 165
  
- 11 APPENDIX H: IBM POWER775 FDT VOLUME TABLES..... 166**
- 11.1 IBM POWER 775 COMPONENT WATER VOLUMES..... 166
- 11.2 IBM POWER 775 SYSTEM WATER VOLUMES ..... 166
- 11.3 IBM POWER 775 SYSTEM WATER CONTAINERS PER FRAME ..... 167
- 11.4 END OF APPENDIX H: IBM POWER775 FDT VOLUME TABLES..... 167
  
- 12 APPENDIX I: POWER775 BULK POWER ENCLOSURE (BPE) PRESSURE TEST PROCEDURE WITHOUT COMPONENTS..... 168**
- 12.1 SAFETY NOTICES..... 168
- 12.2 BACKGROUND:..... 170
- 12.3 PROCEDURE: ..... 171
- 12.4 END OF APPENDIX I: POWER775 BULK POWER ENCLOSURE (BPE) PRESSURE TEST PROCEDURE WITHOUT COMPONENTS ..... 184

## Figure List

Figure 1 BPE Locations.....	10
Figure 2 Front of BPEs (Most Hardware Removed For Clarity).....	11
Figure 3 UEPO Panel Location on Front Door.....	15
Figure 4 CEC Locations (front of rack).....	18
Figure 5 Front Door Open.....	22
Figure 6 Front Door Removal.....	23
<b>Figure 7 Hazardous Voltage, Current, or Energy</b> .....	<b>23</b>
Figure 8 Power Cord/Flexible Power Cable & BPR Locations.....	25
Figure 9 Power Cord/Flexible Power Cable LED shown not lit due to wall CB turned off.....	26
Figure 10 Removal of UEPO Panel from Frame.....	27
Figure 11 UEPO Service Position.....	28
Figure 12 Remove Cover Latch Bracket.....	29
Figure 13 BPA Cable Bundles (front-view).....	30
Figure 14 Typical HPIC Cable.....	31
Figure 15 Typical Ethernet Communications Cable7.....	32
Figure 16 Raceway Retention Screw.....	32
Figure 17 UPIC Raceway Removal.....	33
Figure 18 Cross section view of side cover interference with HPIC raceway.....	34
Figure 19 Front left view of rack to show where to pull on side cover.....	34
Figure 20 HPIC Raceway Removal.....	35
Figure 21 Front-left BPE Mounting Bracket.....	35
Figure 22 Front-right Mounting Standoff.....	36
Figure 23 BPE-B Cables Dressed/Secured Clear of Lift Tool (Larger configuration).....	37
Figure 24 Lift Tool Components (Do not move Lift Tool in this state).....	38
Figure 25 Lift Tool Winch & Winch Bracket.....	40
Figure 26 Frame Rear Mounting Bracket.....	40
Figure 27 Frame Front Mounting Bracket.....	41
Figure 28 Front & Center Table Latches.....	41
Figure 29 Front Table Stop.....	42
Figure 30 Lift Tool Mounting Bracket Attachment.....	42
Figure 31 BPD Safety Latch Location (similar for BPR & BPCB too).....	43
Figure 32 BPR Safety Strap Attached to BPR (similar for BPD also).....	44
Figure 33 Rear Lift Tool Configuration – BPR Removal.....	45
Figure 34 Lift Tool Rear Safety Stop Rod.....	46
Figure 35 T01 Power Cord/Flexible Power Cable Service.....	47
Figure 36 Rear-right Retention Bracket.....	48
Figure 37 Remove transfer cart guard rails.....	49
<b>Figure 38 Lift tool showing white roller engagement area and the transfer cart black rubber guides</b> .....	<b>49</b>
<b>Figure 39 Transfer cart coupled to lift tool</b> .....	<b>50</b>
<b>Figure 40 Attach winch hook</b> .....	<b>51</b>
<b>Figure 41 Attach winch to transfer cart</b> .....	<b>51</b>
<b>Figure 42 Set winch angle</b> .....	<b>52</b>
<b>Figure 43 Mount BPE Front shipping bracket</b> .....	<b>53</b>
<b>Figure 44 Mount BPE Rear shipping bracket</b> .....	<b>53</b>
<b>Figure 45 Align BPE with transfer cart</b> .....	<b>54</b>
<b>Figure 46 Use winch to pull BPE onto transfer cart</b> .....	<b>55</b>
<b>Figure 47 Attach winch hook</b> .....	<b>56</b>
<b>Figure 48 Attach winch to lift tool</b> .....	<b>56</b>
<b>Figure 49 Raise BPE hold down brackets</b> .....	<b>57</b>
<b>Figure 50 Loosen transfer cart clamps</b> .....	<b>58</b>
<b>Figure 51 Use winch to pull BPE onto lift tool</b> .....	<b>58</b>
Figure 52 BPE Mounting Bracket Removal.....	60

Figure 53 Proper BPA Cable Routing .....	61
Figure 54 Proper BPA-A Cable Routing .....	62
Figure 55 Proper BPA-B Cable Routing .....	63
Figure 56 Proper CEC Drawer Cable Routing .....	64
Figure 57 T01 Power Cord/Flexible Power Cable Service.....	65
<b>Figure 58 Front Door Install.....</b>	<b>69</b>
Figure 59 HMC Frames.....	70
Figure 60 Launch Frame Advanced System Management (ASM).....	71
Figure 61 Select BPC FSP SIDE_A .....	71
Figure 62 ASM Login.....	72
Figure 63 ASM Service Processor Command Line.....	73

## Table List

Table 1 Release / Revision History.....	7
Table 2 Required Documents .....	7
Table 3 Acronyms / Abbreviations.....	9
Table 4 Power Cord / Connected BPR Locations Summary .....	25
Table 5 IBM Power 775 Component Water Volumes.....	166
Table 6 IBM Power 775 System Water Volume (Liters) .....	166
Table 7 IBM Power 775 System Water Volume (Gallons) .....	166
Table 8 IBM Power 775 Required Number of System Water Containers per Frame.....	167

# 1 GENERAL

## 1.1 Release / Revision History

File Name	Date	Description
"p775_bpe.pdf"	12/16/2011	Initial version out for formal review.
"p775_bpe.pdf"	3/7/2012	BPE FDT & base FDT procedure updates. BPA location typo fixed.
"p775_bpe.pdf"	8/28/2012	Updated BPE FDT Pressure Test and Transfer Cart procedure. Added cable raceway / side cover mount interference note to Steps 33 & 107. Changed 5mm hex bit to 6mm in Step 47.

**Table 1 Release / Revision History**

- Do not make any unauthorized alterations to the document.
- Report any deviations from this procedure through the appropriate Product Engineering channels.
- Destroy entire document when no longer needed, recalled, or obsolete.

## 1.2 Where to find this document

The current "Power775 Bulk Power Enclosure (BPE) Service Procedure" document is "p775\_bpe.pdf" which is to be downloaded from:

InfoCenter Website: <http://publib.boulder.ibm.com/infocenter/powersys/v3r1m5/topic/p7ee2/p7ee2kickoff.htm>

Click "PDF files for the IBM Power 775 Supercomputer (9125-F2C) removing and replacing parts"

Under "Frame Power components", click "Bulk Power Enclosure (BPE)" to download PDF file "p775\_bpe.pdf"

This is the only valid source for the latest Power775 Bulk Power Enclosure (BPE) Service Procedure.

## 1.3 Required Documents

Document	PN	Location
Safety Notices <a href="http://publib.boulder.ibm.com/infocenter/powersys/v3r1m5/topic/p7hdx/G229-9054.pdf">http://publib.boulder.ibm.com/infocenter/powersys/v3r1m5/topic/p7hdx/G229-9054.pdf</a>	Doc# G229-9054	InfoCenter *

**Table 2 Required Documents**

\*InfoCenter Website: <http://publib.boulder.ibm.com/infocenter/powersys/v3r1m5/topic/p7ee2/p7ee2kickoff.htm>

## 1.4 Acronyms / Abbreviations

Acronym/Abbreviation	Definition	Details
BPA	Bulk Power Assembly	BPE populated with BPCH, BPD, BPRs, & BPFs
BPCH	Bulk Power Controller Hub	Referred to as BPC on the HMC
BPD	Bulk Power Distributor	
BPE	Bulk Power Enclosure	BPEs is plural
BPF	Bulk Power Fan	BPFs is plural
BPR	Bulk Power Regulator	BPRs is plural
CB	Circuit Breaker	Branch circuit wall CB or PDU CB is part of customer's facilities power infrastructure
CEC	Central Electronics Complex	Also referred to as the NODE-P7IH on the Rating Labels
DCCA	Distributed Converter & Control Assembly	The Power Supply for CEC and DE are called the CEC DCCA and DE DCCA, respectively
DE	Disk Enclosure	
EDFI	Error Detection / Fault Isolation	Power/Thermal firmware diagnostic function
FRU	Field Replaceable Unit	
FSP	Flexible Service Processor	
GPFS	Global Parallel File System	IBM's file system utilizing software RAID
HDD	Hard Disk Drive	This also means hard drive
HMC	Hardware Maintenance Console	
HPC	High Performance Computing	
LED	Light Emitting Diode	
LIC	Licensed Internal Code	Specifically Power/Thermal firmware in this procedure's context
MTMS	Machine Type, Model, Serial #	
PCB	Printed Circuit Board	
RAID	Redundant Array of Inexpensive Disks	
SAS	Serial Attached SCSI	Protocol used for direct attached storage
SFP	Service Focal Point	Service application on the HMC
SSR	System Service Representative	IBM Field Service personnel
SSD	Solid State Drive	
UEPO	Unit Emergency Power Off	



**Table 3 Acronyms / Abbreviations**

---

## **2 OVERVIEW**

This section is an overview only. Do not start the service procedure until Section 3 which contains the detailed steps.

---

### **2.1 Safety Notices**

Read “Safety\_Notices “ available from InfoCenter – see Section 1.3.

<http://publib.boulder.ibm.com/infocenter/powersys/v3r1m5/topic/p7hdx/G229-9054.pdf>

The following cautions apply to all Power775 service procedures:

**CAUTION:**

**Energy hazard present and Shorting might result in system outage and possible physical injury. Remove all metallic jewelry before servicing. (C001)**

**CAUTION:**

**The doors and covers to the product are to be closed at all times except for service by trained service personnel. All covers must be replaced and doors locked at the conclusion of the service operation. (C013)**

**CAUTION:**

**Servicing of this product or unit is to be performed by trained service personnel only. (C032)**

The following notices specifically pertain to this Power775 service procedure.



**DANGER: Hazardous voltage present. Voltages present constitute a shock hazard, which can cause severe injury or death. (L004)**

---

## 2.2 ATTENTION: File System Risk Statement

The Global Parallel File System (GPFS) implementation of software RAID stripes data across all the Disk Enclosures in the cluster. **If a single Disk Enclosure is powered off while GPFS is active, the file system will go into panic and become unavailable.**

---

## 2.3 BPE Description

Referring to Figure 1 below, BPE-A is at location U-P2 and BPE-B is at U-P1 (where U is the MTMS 9125 F2C Serial #) at the top of the rack. Both BPEs extend through the entire depth of the rack so they can each be seen from both the front and back sides. This full-depth BPE characteristic is different from other IBM high-end servers.

Also, refer to Figure 2 on the next page, which is a drawing of the both BPEs as seen from the front of the rack.

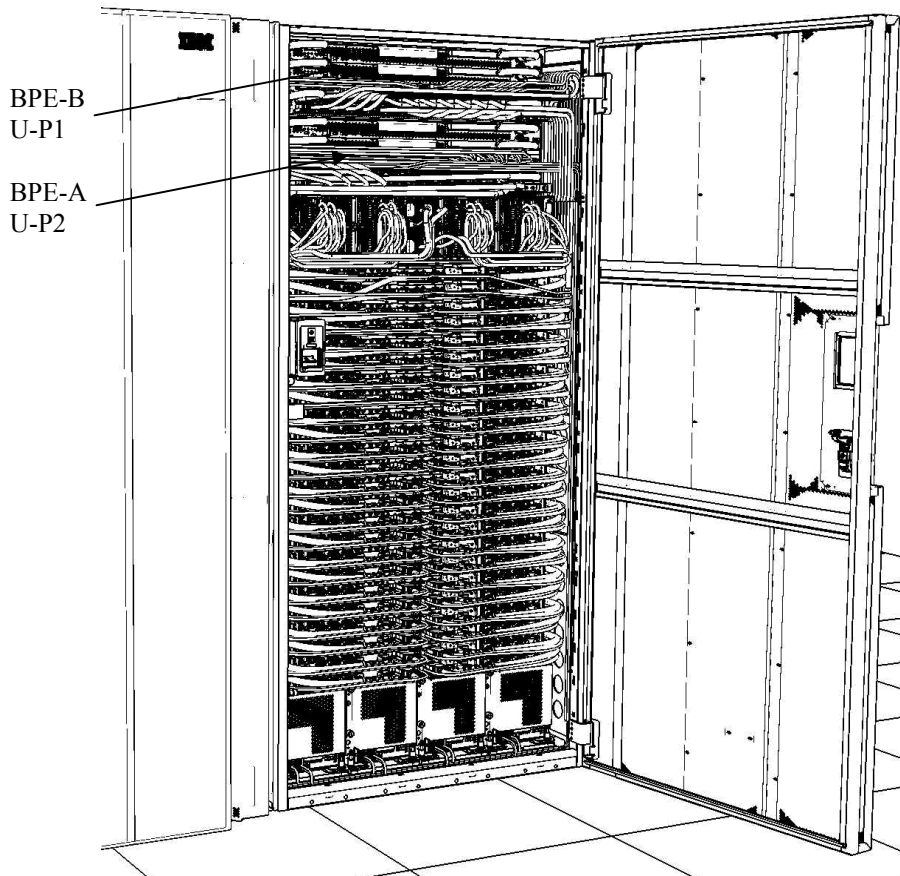
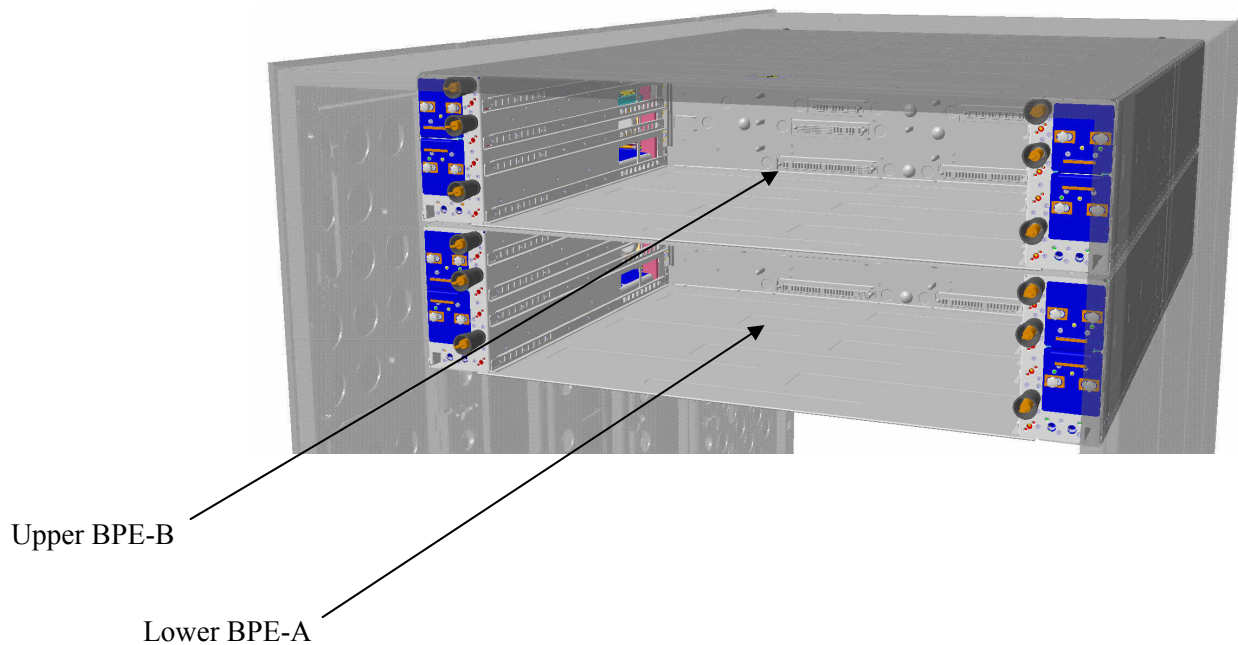


Figure 1 BPE Locations

## 2.4 Background

The BPE is the cage/enclosure that houses the BPA FRUs (BPCH, BPD, BPRs, & BPFs) and the mid-plane printed circuit board which provides all the electrical interconnects. Both the upper and lower BPEs are located near the top of the rack and are serviceable/replaceable from the front. Each BPA accepts 200-240Vac, 380-440Vac, 480Vac, 380Vdc, or 520Vdc nominal input voltage via 100 or 125A input power cords (2 cords per BPE). A BPE contains up to 6 Bulk Power Regulators (BPRs), 1 Bulk Power Distributor (BPD), 1 Bulk Power Controller Hub (BPCH or sometimes just referred to as BPC), as well as 4 Bulk Power Fans (BPFs). The BPE consists of a central mid-plane circuit board surrounded by a sheet-steel chassis. Two input power connectors are located at the rear of the BPE as part of the N+1=4 redundant power topology. The BPE also houses water cooling manifolds which distribute water to cool the BPRs and BPD. Larger water supply and return couplings for the BPE manifolds are located at the rear of the unit. Smaller water supply and return couplings for the BPRs and BPD are located on each respective assembly. Although the BPE spans nearly the full depth of the rack allowing BPR's to be serviced from both the front and rear, the BPE itself can only be inserted/extracted from the front. Due to the weight and location of the BPE, the BPE must first be depopulated of its BPRs BPD and BPCH prior to removal. When servicing the lower BPE, all UPIC, HPIC, & communications cables on the left side of the rack only must be removed to provide adequate clearance to extract and replace the lower BPE using a custom Lift Tool.



**Figure 2 Front of BPEs (Most Hardware Removed For Clarity)**

## 2.5 Concurrency

The BPE is concurrently maintainable at degraded processor performance levels (-25% of normal processor frequency or approximately 2.85GHz instead of 3.83GHz). This means the customer system administrator needs to be notified and included in planning for BPE service since delays to large HPC job runs could be substantial. Furthermore, BPE replacement is a relatively long and major service procedure that requires operating at N-1 power cord/BPA redundancy for a time. Although everything should go OK, there is a slightly higher risk that another fault occurring during the vulnerable N-1 power cord/BPA service window could change this service procedure from concurrent to non-concurrent.

---

## 2.6 BPE Weight

A depopulated BPE weighs 158 lbs.

---

## 2.7 Required SSRs and Roles

This service procedure requires two SSRs.

---

## 2.8 Estimated Service Time

This procedure can take up to 6 hours.

---

## 2.9 P7IH Hand Tool Kit P/N 74Y0988 Required Tools

- 4mm Hex Driver (1.5-1.75 Nm torque setting) PN 41V1059
- 4mm Hex Driver (2.8 – 3.8 Nm torque setting) PN 74Y0984
- 1/4" drive 7mm socket with 1/4" drive ratchet
- 2mm hex driver (P/N 74Y0983)
- 3/8" drive ratchet (P/N 6428140) depending on the cable location
- 3/8" drive extension (P/N 46K2707)
- 5mm hex socket bit (P/N 74Y0986)
- Torque clutch (P/N 74Y0985)
- 3/8" drive 16mm socket (P/N 5497588)
- Velcro puck (P/N 31L7174)
- Ladder P/N 46G5947
- Stool P/N 93G1147
- Lift Tool P/N 74Y1087
- Power Driver P/N 74Y0981

## **2.10 Overview of Procedure**

This is an overview of the tasks to be performed. Read this overview but do not perform any of the tasks yet.

- 3.1 ASSESS REDUCTION IN PERFORMANCE <= CUSTOMER TASK
- 3.2 IDENTIFY AND REPLACE BPE <= SSR TASK
- 3.3 END OF POWER775 BULK POWER ENCLOSURE (BPE) SERVICE PROCEDURE

---

## 3 SERVICE PROCEDURE

**STOP – Do not proceed** unless you have read “Safety\_Notices\_G229-9054.pdf” which is available from InfoCenter; see Section 1.2

---

### 3.1 Assess reduction in performance <= Customer Task

The Customer System Administrator must be made aware of this service activity since it will degrade processor performance (-25% processor frequency of approximately 2.85GHz instead of the normal 3.83GHz) in the frame with the BPE to be replaced. Be sure to read Section 2.5 Concurrency above also if you have not already.

If the performance reduction can be tolerated at this time, proceed to Section 3.2

If the performance reduction cannot be tolerated, the frame should continue to run with the redundant BPE until the service action can be scheduled.

---

### 3.2 Identify and Replace BPE <= SSR Task

1. You should have downloaded this procedure from the InfoCenter Website listed here to ensure you are using the latest version and ensure no pages are missing by verifying the last section is titled “End of Document”:

<http://publib.boulder.ibm.com/infocenter/powersys/v3r1m5/topic/p7ee2/p7ee2kickoff.htm>

2. If using printed copies of these procedures, then be sure to staple or paperclip the pages together to help keep them in the right page number sequence.
3. An HMC Service Focal Point SRC FRU Call or direction from a higher level of support should have directed you to perform this procedure. The HMC can be accessed via the keyboard/display that resides in the management rack.
4. Locate rack that requires service.
5. If the rack could not be located in Step 4 above, then light the UEPO/BPE Service Identify LED by accessing the **HMC BPC-A ASM SIDE\_A** Service Processor Command Line (Refer to ‘Power775 BPC FSP Command Line Procedure’ in Appendix A of this PDF and select **SIDE\_A** on the **Launch ASM Interface** window) and enter the following at the command prompt (IMPORTANT: DOUBLE-CHECK THE COMMAND IS TYPED IN EXACTLY CORRECT BEFORE PRESSING ENTER BECAUSE EVEN A SINGLE INCORRECT CHARACTER COULD RESULT IN SEVERE UNINTENDED SYSTEM DISRUPTION!!):  

```
bpccmd -c 28aa0001ff01
```

Expect 00aa00 returned which means the command executed properly and reported successful “UEPO/BPE Service Identify LED On” status.

If something different is returned, then contact the next level of support. For reference, the returned “rrsdd” format hexadecimal characters can be translated as follows:

**“rr” Return Code Definitions:**

- 00 = Command executed properly
- 21 = Cage Not Present / Configured
- 22 = FRU Not Present / Configured.
- 27 = Location code error
- 4A = Error in sent command
- 4B = Invalid State
- 95 = BPCH LIC Detected Error
- 96 = Mail-boxing error

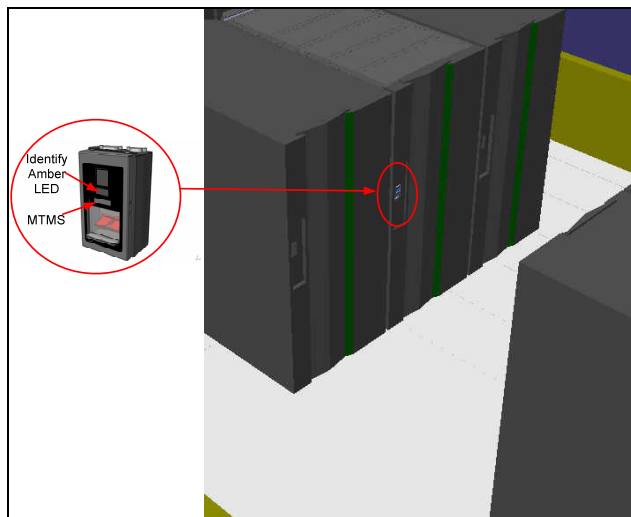
**“ss” Sequence Number:**

- aa = Arbitrary and unimportant

**“dd” Return Data Definitions**

- 00 = UEPO/BPE Service Identify LED turned on successfully. It is OK to continue with the service procedure

6. The UEPO Panel Identify Amber LED should be blinking. Verify the rack and UEPO Panel MTMS (Machine Type Model Serial number) are as expected. The rack level MTMS is located on the face of the UEPO Panel (see Figure 3 UEPO Panel Location on Front Door below). The Green circular lightning-bolt LED indicates that the UEPO loop is complete and it should remain lit throughout the procedure.



**Figure 3 UEPO Panel Location on Front Door**

7. If replacing the BPE-A at BPA-A location U-P2, then make sure the BPE-A status is redundant by sending a BPA-A redundancy command to the BPCH FSP. To do this access the **HMC BPC-A ASM SIDE\_A** Service Processor Command Line (Refer to 'Power775 BPC FSP Command Line Procedure' in Appendix A of this PDF and ensure **ASM SIDE\_A** is active per Step 12) and enter the following at the command prompt (IMPORTANT: DOUBLE-CHECK THE COMMAND IS TYPED IN EXACTLY CORRECT BEFORE PRESSING ENTER BECAUSE EVEN A SINGLE INCORRECT CHARACTER COULD RESULT IN SEVERE UNINTENDED SYSTEM DISRUPTION!!):  

```
bpccmd -c 9baa0000ff01
```

Expect 00aa00 returned which means the command executed properly and reported successful "Redundant BPE-A/BPA-A" status or expect 00aa03 returned which means the command executed properly and reported successful "Redundant BPE-A/BPA-A if CECs in Degraded Low Power Mode" status..

If something different is returned, then contact the next level of support. For reference, the returned "rrssdd" format hexadecimal characters can be translated as follows:

**"rr" Return Code Definitions:**

00 = Command executed properly  
21 = Cage Not Present / Configured  
22 = FRU Not Present / Configured.  
27 = Location code error  
43 = Not valid for this FRU  
96 = Mail-boxing error

**"ss" Sequence Number:**

aa = Arbitrary and unimportant

**"dd" Return Data Definitions:**

00 = Redundant status. It is OK to replace the BPE-A and continue with Step 8  
01 = Non-redundant status. It is NOT OK to replace the BPE-A. Please contact next level of support  
03 = Redundant only if you enter degraded processor frequency Low Power Mode. Place CEC Drawers in Low Power Mode before replacing the BPE-A and continuing with Step 8



8. If replacing the BPE-B at BPA-B location U-P1, then make sure the BPE-B status is redundant by sending a BPA-B redundancy command to the BPCH FSP. To do this open a new **ASM SIDE\_B** window to access the **HMC BPC-B ASM SIDE\_B** Service Processor Command Line (Refer to 'Power775 BPC FSP Command Line Procedure' in Appendix A of this PDF and select **SIDE\_B** on the **Launch ASM Interface** window) and enter the following at the command prompt (IMPORTANT: DOUBLE-CHECK THE COMMAND IS TYPED IN EXACTLY CORRECT BEFORE PRESSING ENTER BECAUSE EVEN A SINGLE INCORRECT CHARACTER COULD RESULT IN SEVERE UNINTENDED SYSTEM DISRUPTION!!):

```
bpccmd -c 9baa0000ff01
```

Expect 00aa00 returned which means the command executed properly and reported successful "Redundant BPE-B/BPA-B" status or expect 00aa03 returned which means the command executed properly and reported successful "Redundant BPE-B/BPA-B if CECs in Degraded Low Power Mode" status.

If something different is returned, then contact the next level of support. For reference, the returned "rrsdd" format hexadecimal characters can be translated as follows:

**"rr" Return Code Definitions:**

00 = Command executed properly  
21 = Cage Not Present / Configured  
22 = FRU Not Present / Configured.  
27 = Location code error  
43 = Not valid for this FRU  
96 = Mail-boxing error

**"ss" Sequence Number:**

aa = Arbitrary and unimportant

**"dd" Return Data Definitions:**

00 = Redundant status. It is OK to replace the BPE-B and continue with Step 10  
01 = Non-redundant status. It is NOT OK to replace the BPE-B. Please contact next level of support  
03 = Redundant only if you enter degraded processor frequency Low Power Mode status.. Place CEC Drawers in Low Power Mode before replacing the BPE-B and continuing with Step 10

9. Pressure Test the new replacement BPE by performing Appendix I: Power775 Bulk Power Enclosure (BPE) Pressure Test Procedure without components starting on page 168 of this PDF.

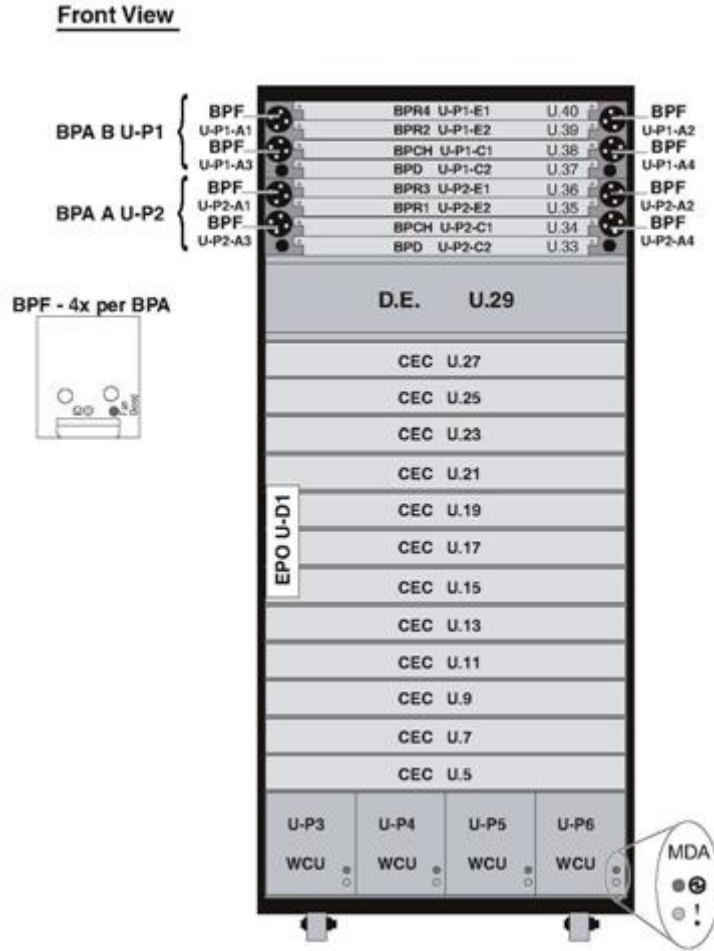


Figure 4 CEC Locations (front of rack)

- If 00aa00 “Redundant BPE/BPA” status was returned from Step 7 or 8, then continue with Step 13. If 00aa03 “Redundant BPE/BPA if CECs in Degraded Low Power Mode” status was returned from Step 7 or 8, then continue here with Step 10. Put **all** CEC Drawers in Low Power Mode by sending the following commands to the BPC FSP for all configured CEC Drawers (reference Figure 4 above). To do this access the **HMC BPC-A ASM SIDE\_A** Service Processor Command Line (Refer to ‘Power775 BPC FSP Command Line Procedure’ in Appendix A of this PDF and ensure **ASM SIDE\_A** is active per Step 12 of Appendix A) and enter one of the commands below for each CEC Drawer installed (**IMPORTANT: DOUBLE-CHECK THE COMMAND IS TYPED IN EXACTLY CORRECT BEFORE PRESSING ENTER BECAUSE EVEN A SINGLE INCORRECT CHARACTER COULD RESULT IN SEVERE UNINTENDED SYSTEM DISRUPTION!!**):

bpccmd -c 87aa000003	(CEC U5)
bpccmd -c 87aa000004	(CEC U7)
bpccmd -c 87aa000005	(CEC U9)
bpccmd -c 87aa000006	(CEC U11)
bpccmd -c 87aa000007	(CEC U13)
bpccmd -c 87aa000008	(CEC U15)
bpccmd -c 87aa000009	(CEC U17)
bpccmd -c 87aa00000a	(CEC U19)
bpccmd -c 87aa00000b	(CEC U21)
bpccmd -c 87aa00000c	(CEC U23)
bpccmd -c 87aa00000d	(CEC U25)
bpccmd -c 87aa00000e	(CEC U27)

Expect 00aa00 returned for each command which means the command executed properly and reported successful "Low Power Mode CEC Drawer" status.

If something different is returned, then contact the next level of support. For reference, the returned "rrsdd" format hexadecimal characters can be translated as follows:

**"rr" Return Code Definitions:**

00 = Command executed properly  
21 = Cage Not Present / Configured  
22 = FRU Not Present / Configured.  
27 = Location code error  
43 = Not valid for this FRU  
96 = Mail-boxing error

**"ss" Sequence Number:**

aa = Arbitrary and unimportant

**"dd" Return Data Definitions:**

00 = Low Power Mode status. If commands for all installed CEC Drawers returned 00, then it is OK to replace the BPE and continue with Step 11  
01 = Not Low Power Mode status. It is NOT OK to replace the BPE. Please contact next level of support

11. If replacing the BPE-A at BPA-A location U-P2, then make sure the BPE-A status is now redundant by sending a BPA-A redundancy command to the BPCH FSP. To do this access the **HMC BPC-A ASM SIDE\_A** Service Processor Command Line (Refer to ‘Power775 BPC FSP Command Line Procedure’ in Appendix A of this PDF and ensure **ASM SIDE\_A** is active per Step 12 of Appendix A) and enter the following at the command prompt (IMPORTANT: DOUBLE-CHECK THE COMMAND IS TYPED IN EXACTLY CORRECT BEFORE PRESSING ENTER BECAUSE EVEN A SINGLE INCORRECT CHARACTER COULD RESULT IN SEVERE UNINTENDED SYSTEM DISRUPTION!!):  

```
bpccmd -c 9baa0000ff01
```

Expect 00aa00 returned which means the command executed properly and reported successful “Redundant BPE-A/BPA-A” status.

If something different is returned, then contact the next level of support. For reference, the returned “rrssdd” format hexadecimal characters can be translated as follows:

**“rr” Return Code Definitions:**

00 = Command executed properly  
21 = Cage Not Present / Configured  
22 = FRU Not Present / Configured.  
27 = Location code error  
43 = Not valid for this FRU  
96 = Mail-boxing error

**“ss” Sequence Number:**

aa = Arbitrary and unimportant

**“dd” Return Data Definitions:**

00 = Redundant status. It is OK to replace the BPE-A and continue with Step 13  
01 = Non-redundant status. It is NOT OK to replace the BPE-A. Please contact next level of support  
02 = Redundant only during Low Power Mode status. Place CEC Drawers in Low Power Mode before replacing the BPE-A and continuing with Step 13

12. If replacing the BPE-B at BPA-B location U-P1, then make sure the BPE-B status is now redundant by sending a BPA-B redundancy command to the BPCH FSP. To do this open a new ASM window to access the **HMC BPC-B ASM SIDE\_B** Service Processor Command Line (Refer to 'Power775 BPC FSP Command Line Procedure' in Appendix A of this PDF and ensure **ASM SIDE\_B** is active per Step 12 of Appendix A) and enter the following at the command prompt (IMPORTANT: DOUBLE-CHECK THE COMMAND IS TYPED IN EXACTLY CORRECT BEFORE PRESSING ENTER BECAUSE EVEN A SINGLE INCORRECT CHARACTER COULD RESULT IN SEVERE UNINTENDED SYSTEM DISRUPTION!!):

```
bpccmd -c 9baa0000ff01
```

Expect 00aa00 returned which means the command executed properly and reported successful "Redundant BPE-B/BPA-B" status.

If something different is returned, then contact the next level of support. For reference, the returned "rrsdd" format hexadecimal characters can be translated as follows:

**"rr" Return Code Definitions:**

00 = Command executed properly  
21 = Cage Not Present / Configured  
22 = FRU Not Present / Configured.  
27 = Location code error  
43 = Not valid for this FRU  
96 = Mail-boxing error

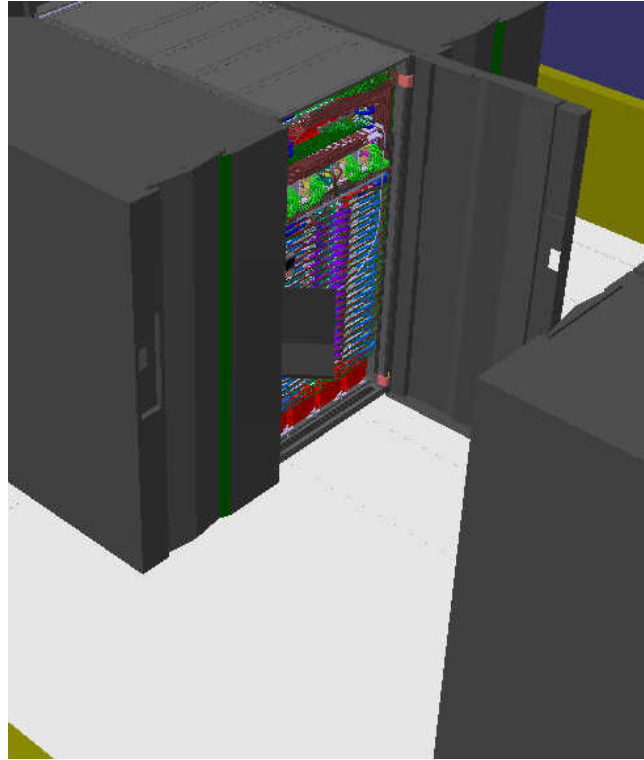
**"ss" Sequence Number:**

aa = Arbitrary and unimportant

**"dd" Return Data Definitions:**

00 = Redundant status. It is OK to replace the BPE-B and continue with Step 13  
01 = Non-redundant status. It is NOT OK to replace the BPE-B. Please contact next level of support  
02 = Redundant only during Low Power Mode status. Place CEC Drawers in Low Power Mode before replacing the BPE-B and continuing with Step 13

13. Open the front door by pushing in the door lock and releasing the latch. Then open the front door as shown in Figure 5 below.



**Figure 5 Front Door Open**

14. Remove the Front Door by positioning it slightly past 90 degrees open and facing inside the door with hands on the cross bars (see Figure 6 Front Door Removal). Then lift the door up and off the hinge pins and remove it. The front door weights 37lbs (16.8 kg).



**Figure 6 Front Door Removal**

15. From the rear of the rack, open the Rear Door Heat Exchanger (RDHX) door.

**DANGER:**

**Hazardous voltage present. Voltages present constitute a shock hazard, which can cause severe injury or death. (L004)**



**Figure 7 Hazardous Voltage, Current, or Energy**

16. If replacing the lower BPE-A at BPA-A location U-P2, issue a BPE deactivate command to the BPCH-A FSP. NOTE IT IS VERY IMPORTANT TO ENTER THIS COMMAND ON THE CORRECT ASM SIDE! To do this access the **HMC BPC-A ASM SIDE\_A** Service Processor Command Line (Refer to 'Power775 BPC FSP Command Line Procedure' in Appendix A of this PDF and ensure **ASM SIDE\_A** is active per Step 12 of Appendix A) and enter the following at the command prompt (IMPORTANT: DOUBLE-CHECK THE COMMAND IS TYPED IN EXACTLY CORRECT BEFORE PRESSING ENTER BECAUSE EVEN A SINGLE INCORRECT CHARACTER COULD RESULT IN SEVERE UNINTENDED SYSTEM DISRUPTION!!):  

```
bpccmd -c 10aa0000ff01
```

No return code is expected because the BPCH-A was deactivated and can't respond. However, any previous command return code will still be there.

17. If replacing the upper BPE-B at BPA-B location U-P1, issue a BPE deactivate command to the BPCH-B FSP. NOTE IT IS VERY IMPORTANT TO ENTER THIS COMMAND ON THE CORRECT ASM SIDE! To do this access the **HMC BPC-B ASM SIDE\_B** Service Processor Command Line (Refer to 'Power775 BPC FSP Command Line Procedure' in Appendix A of this PDF and ensure **ASM SIDE\_B** is active per Step 12 of Appendix A) and enter the following at the command prompt (IMPORTANT: DOUBLE-CHECK THE COMMAND IS TYPED IN EXACTLY CORRECT BEFORE PRESSING ENTER BECAUSE EVEN A SINGLE INCORRECT CHARACTER COULD RESULT IN SEVERE UNINTENDED SYSTEM DISRUPTION!!):  

```
bpccmd -c 10aa0000ff01
```

No return code is expected because the BPCH-B was deactivated and can't respond. However, any previous command return code will still be there.

18. Check to ensure all the LEDs turned off on the BPA (that is the BPCH, BPD, BPRs, & BPFs) just deactivated (except for the BPCH PWR & CMPLT LEDs which will remain on).



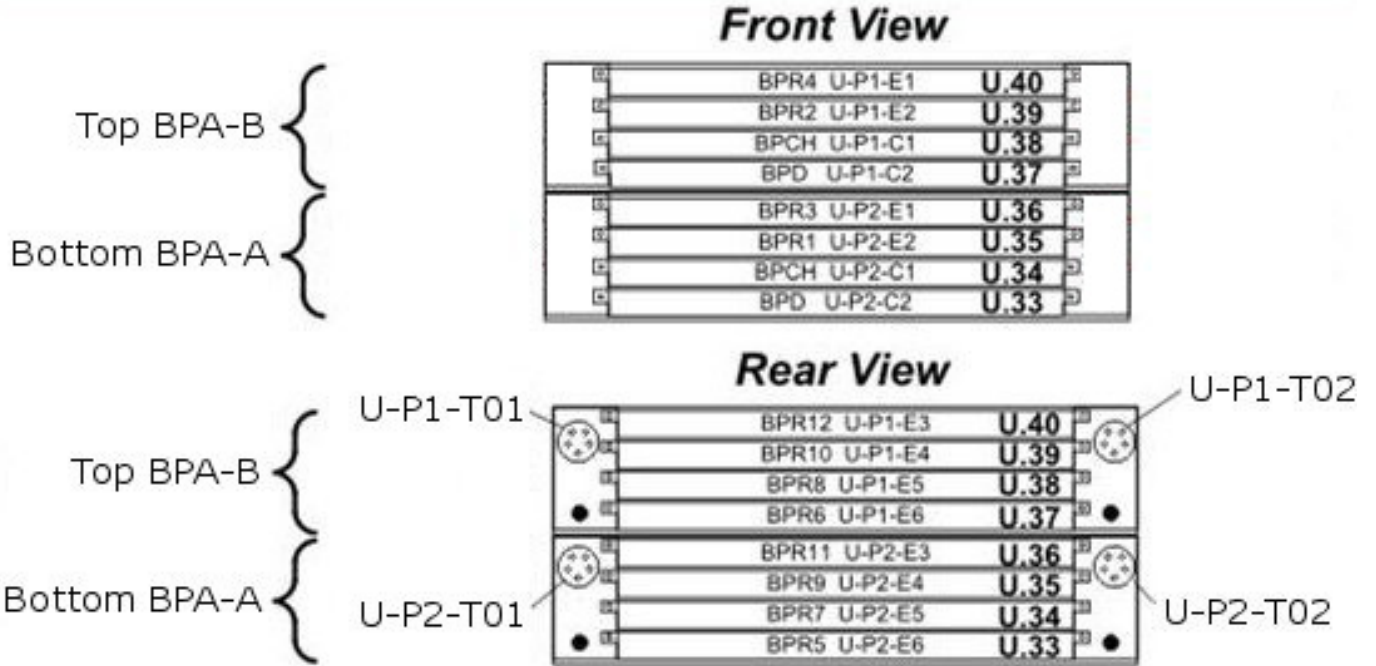
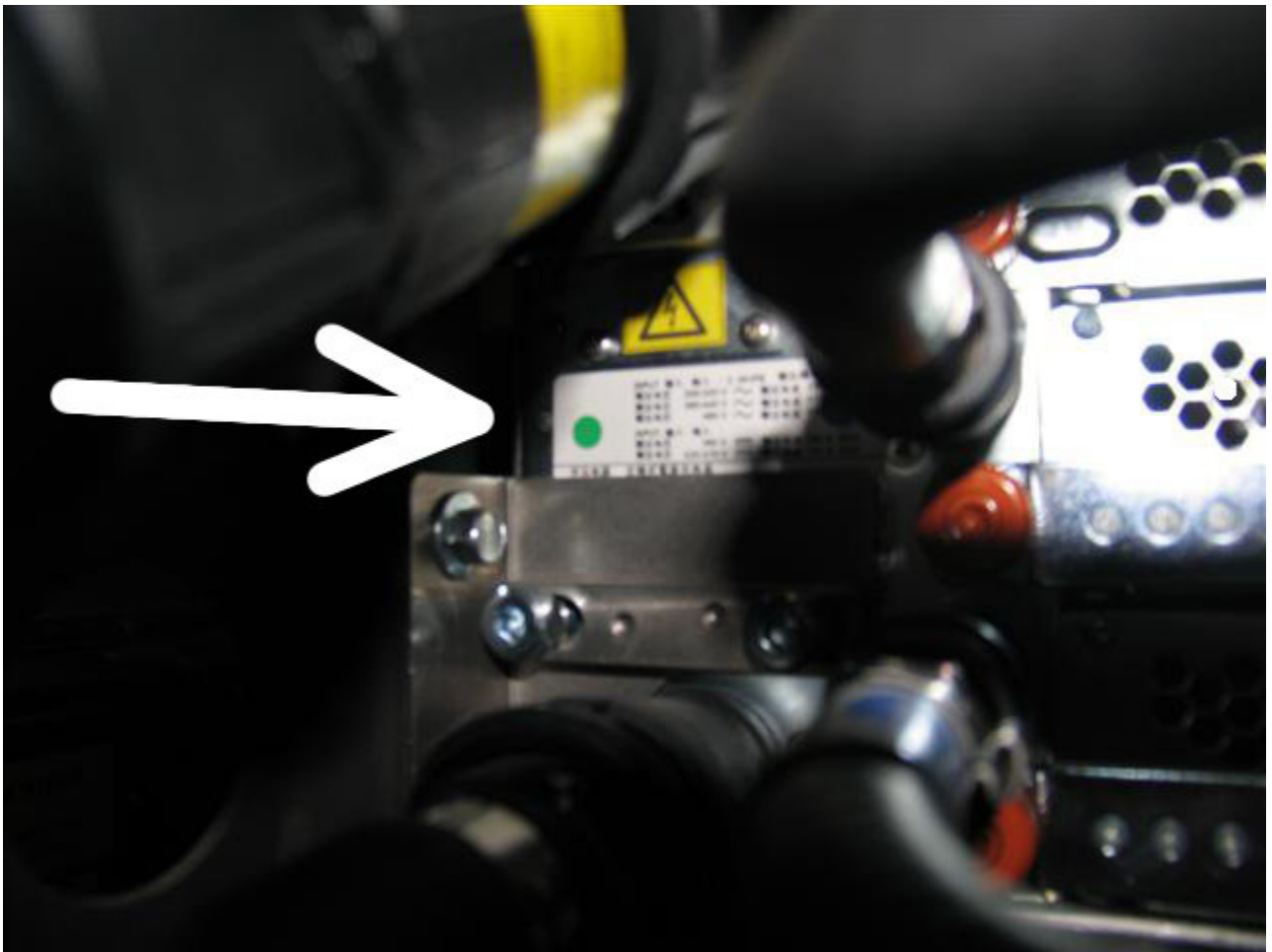


Figure 8 Power Cord/Flexible Power Cable & BPR Locations

Power Cord / Flexible Power Cable Location	Location Description	Connected BPRs
<b>U-P2-T01</b>	Rear of Rack Bottom BPA-A Left-hand-side	U-P2-E1 (BPR3)
		U-P2-E2 (BPR1)
		U-P2-E3 (BPR11)
<b>U-P2-T02</b>	Rear of Rack Bottom BPA-A Right-hand-side	U-P2-E4 (BPR9)
		U-P2-E5 (BPR7)
		U-P2-E6 (BPR5)
<b>U-P1-T01</b>	Rear of Rack Top BPA-B Left-hand-side	U-P1-E1 (BPR4)
		U-P1-E2 (BPR2)
		U-P1-E3 (BPR12)
<b>U-P1-T02</b>	Rear of Rack Top BPA-B Right-hand-side	U-P1-E4 (BPR10)
		U-P1-E5 (BPR8)
		U-P1-E6 (BPR6)

Table 4 Power Cord / Connected BPR Locations Summary

19. Turn off the BPR slide-switches on all 6 BPRs (front and rear) from the BPA that just had its “BPR Good” LEDs turned off.
20. Have the customer or approved delegate turn off the branch circuit wall CB for the two Power Cords/Flexible Power Cables attached to the BPA just turned off (reference Figure 8 and Table 4 above). Ensure the LED below the corresponding BPE T01 and T02 input connector labels are no longer lit as illustrated in Figure 9 below. Note that you may need to use the ladder or step stool to see the Power Cord LEDs because sometimes they are blocked from sight due to being just above the rear retention brackets.



**Figure 9 Power Cord/Flexible Power Cable LED shown not lit due to wall CB turned off**

21. If replacing the lower BPE-A, loosen the blue colored thumb screw located at the bottom of the UEPO Panel using the red handled Hex Driver torque tool P/N 41V1059 (4mm Hex Driver 1.5-1.75 Nm) provided in the tool kit (see Figure 10 below).



**Figure 10 Removal of UEPO Panel from Frame**

22. If replacing the lower BPE-A, unhook the UEPO Panel assembly from the rack by sliding it upward and then away from the rack. The UEPO cables remain plugged and fastened to the UEPO Panel throughout this process.

23. If replacing upper BPE-B, then continue with Step 24. If servicing the lower BPE-A, temporarily relocate the UEPO to the upper service position as described in this Step 23. This will allow adequate service clearance to unplug and manipulate cables out of the BPD and BPCH. Once all of the BPA-A cables are unplugged, the UEPO will again need to be moved prior to extraction of the lower BPE-A. This is only required when servicing the lower BPE-A.

Leaving the UEPO Panel cables attached and red switch in the ON / UP position, shift the UEPO Panel upward to disengage it from the rack, then attach it in the upper left corner of the rack in the service/shipping position (see Figure 11 below).

Upper UEPO Mounting Bracket

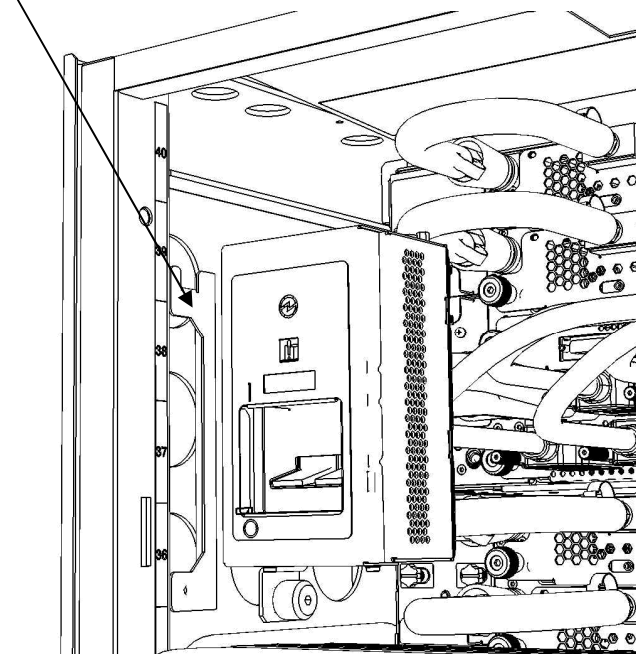
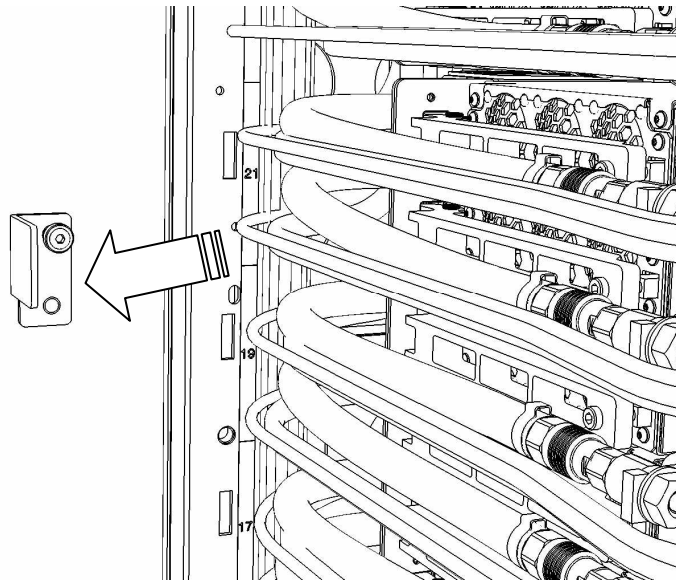


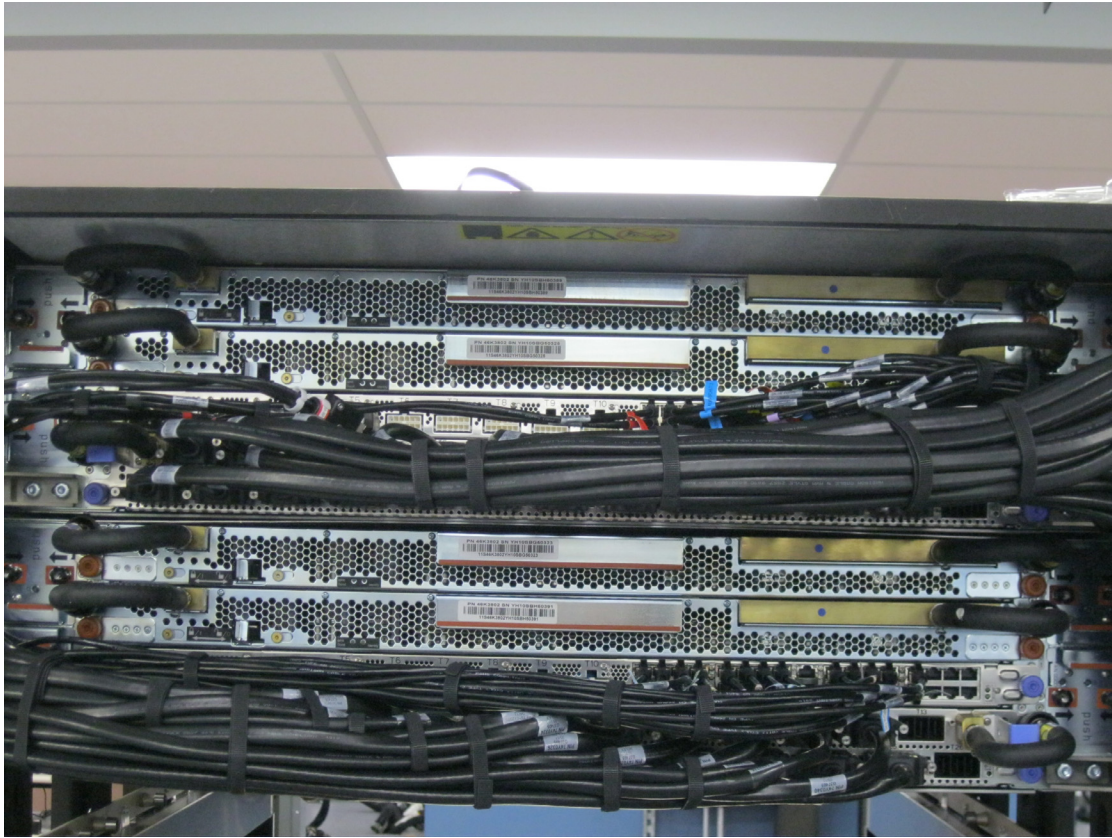
Figure 11 UEPO Service Position

24. If replacing upper BPE-B, continue with Step 25. If servicing the lower BPE-A, remove the cover latch bracket on the left vertical rack member using the 4mm hex driver 41V1059 (see Figure 12 below).



**Figure 12 Remove Cover Latch Bracket**

25. Remove Velcro ties from the cable bundle in front of the BPE being replaced (see Figure 13 below).



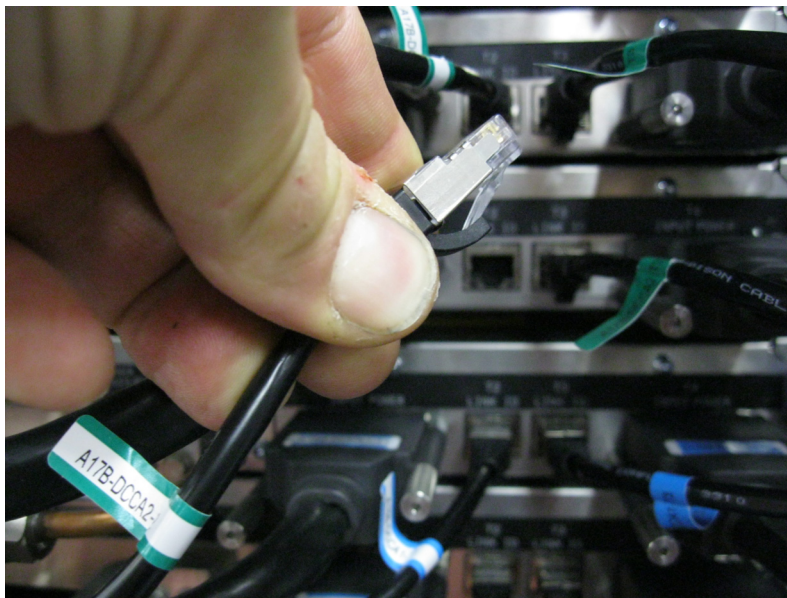
**Figure 13 BPA Cable Bundles (front-view)**

26. Unplug each HPIC connector from the BPD using 2mm hex driver 74Y0983 to unseat the jack screws. The ladder (P/N 46G5947) or Stool (P/N 93G1147) may be required. Note the information on the cable location labels and take notice of the general plugging order for future reference (see typical HPIC photo in Figure 14 below). The Service Card may be available as a general location reference diagram also.



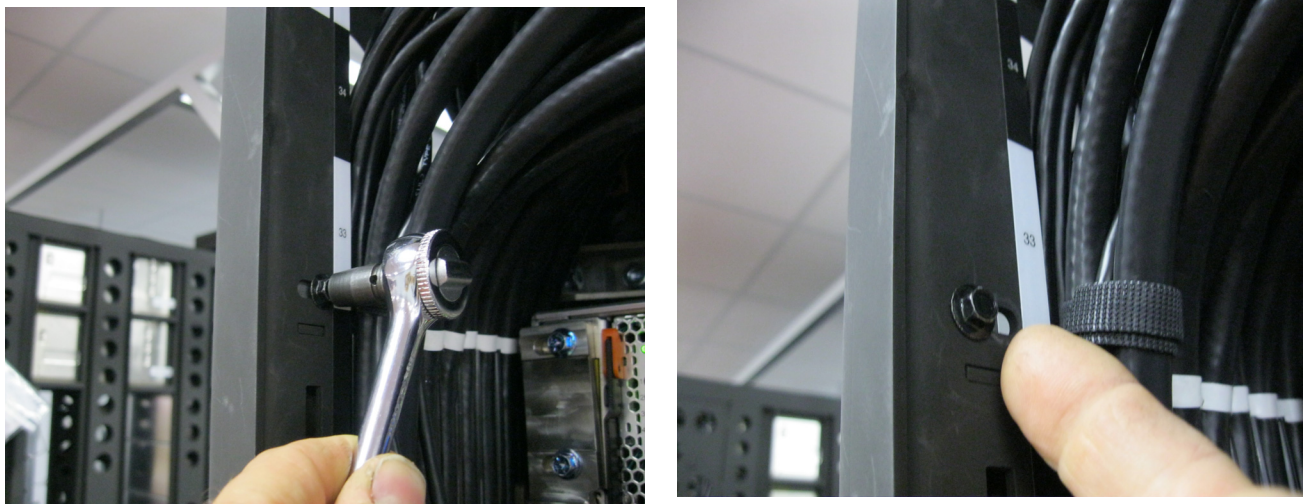
**Figure 14 Typical HPIC Cable**

27. Unplug all communication (Ethernet-to-Ethernet) cables from the BPCB by simply pressing the retention latch on the connector housing, then removing the connector from the receptacle. Note the information on the cable location label and take note of the general plugging order for future reference (see typical Ethernet cable photo example in Figure 15 below)



**Figure 15 Typical Ethernet Communications Cable7**

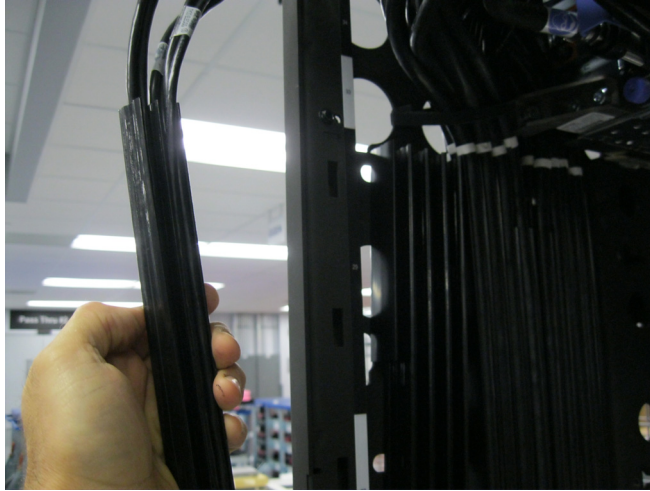
28. If replacing BPE-A, then starting from the lowest CEC Drawer and/or Disk Enclosure, unplug the HPIC and Ethernet connectors entering from the left side of the drawer similar to Step 26 above (reference Figure 14 and Figure 15).
29. If replacing BPE-A, then remove Velcro ties from the left side of each CEC Drawer and allow the cables to hang downward.
30. If replacing BPE-A, then all unplugged cables must now be removed from the rack while remaining in their respective raceways. This is required to prevent damage of the cables during the BPE-A removal/installation service and allow adequate service clearance for the custom Lift Tool provided for extracting the BPR's, BPD, and BPCH, as well as the BPE.
31. If replacing BPE-A, then loosen UPIC raceway retention bracket screw using the 1/4" socket drive ratchet and a 7mm socket. Slide the screw and bracket forward (see photos in Figure 16 Raceway Retention Screw below).



**Figure 16 Raceway Retention Screw**



32. If replacing BPE-A, then shift UPIC raceway upward and remove it from the rack. Allow it to hang in front of the CEC Drawers and/or Disk Enclosures (see photo in Figure 17 UPIC Raceway Removal below).



**Figure 17 UPIC Raceway Removal**

33. If replacing BPE-A, once the UPIC raceway has been removed, slide the first HPIC raceway forward until it disengages from the mounting slots. It can then be removed from the rack and allowed to hang in front of the CEC Drawers and/or Disk Enclosures (see Figure 20 HPIC Raceway Removal below).

Note that the first DCCA Power Cable Raceway to be removed has a slight mechanical interference that makes the removal of this cable raceway somewhat challenging. There is a mechanical interference from the side cover of the frame to the shoulder screw that affixes the raceway to the frame (see Figure 18). In order to easily slide out the first cable raceway, it may be necessary to slightly pull the side cover away from the body of the frame with your fingers. The mechanical interference is located at the vertical center of the U.27 location in the frame, there is a white label with “27” in black text on the frame at this position. The side cover is tightly fixed to the frame just below the U.27 location, so you will only need to pull back on the side cover by 2-3mm (see Figure 19).

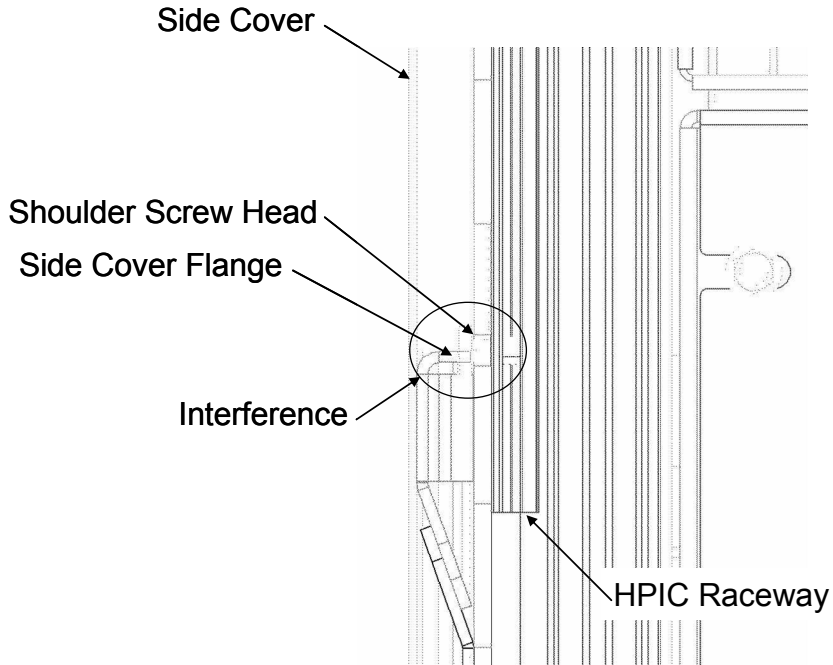


Figure 18 Cross section view of side cover interference with HPIC raceway

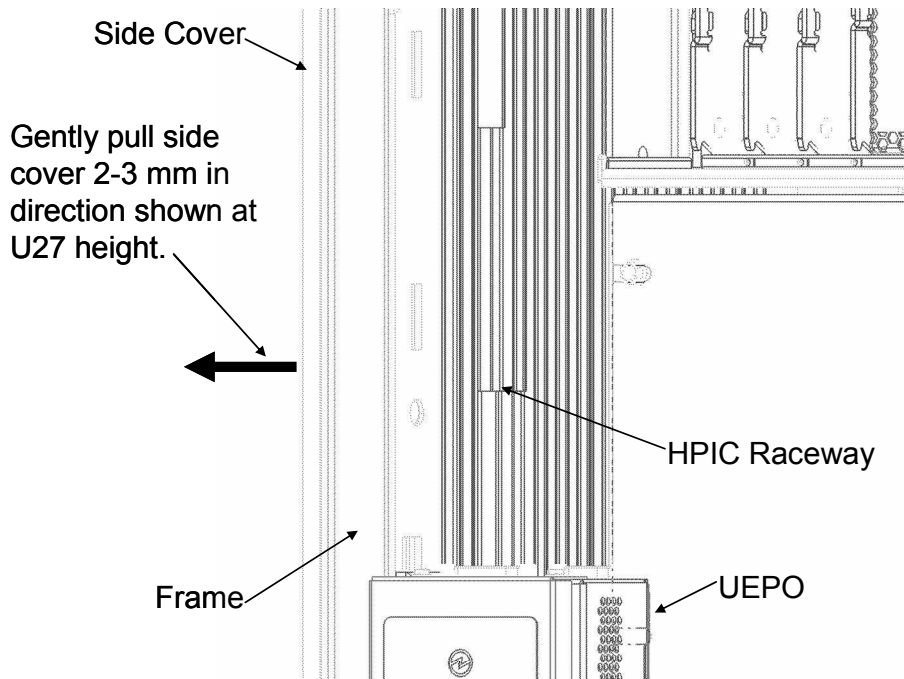


Figure 19 Front left view of rack to show where to pull on side cover



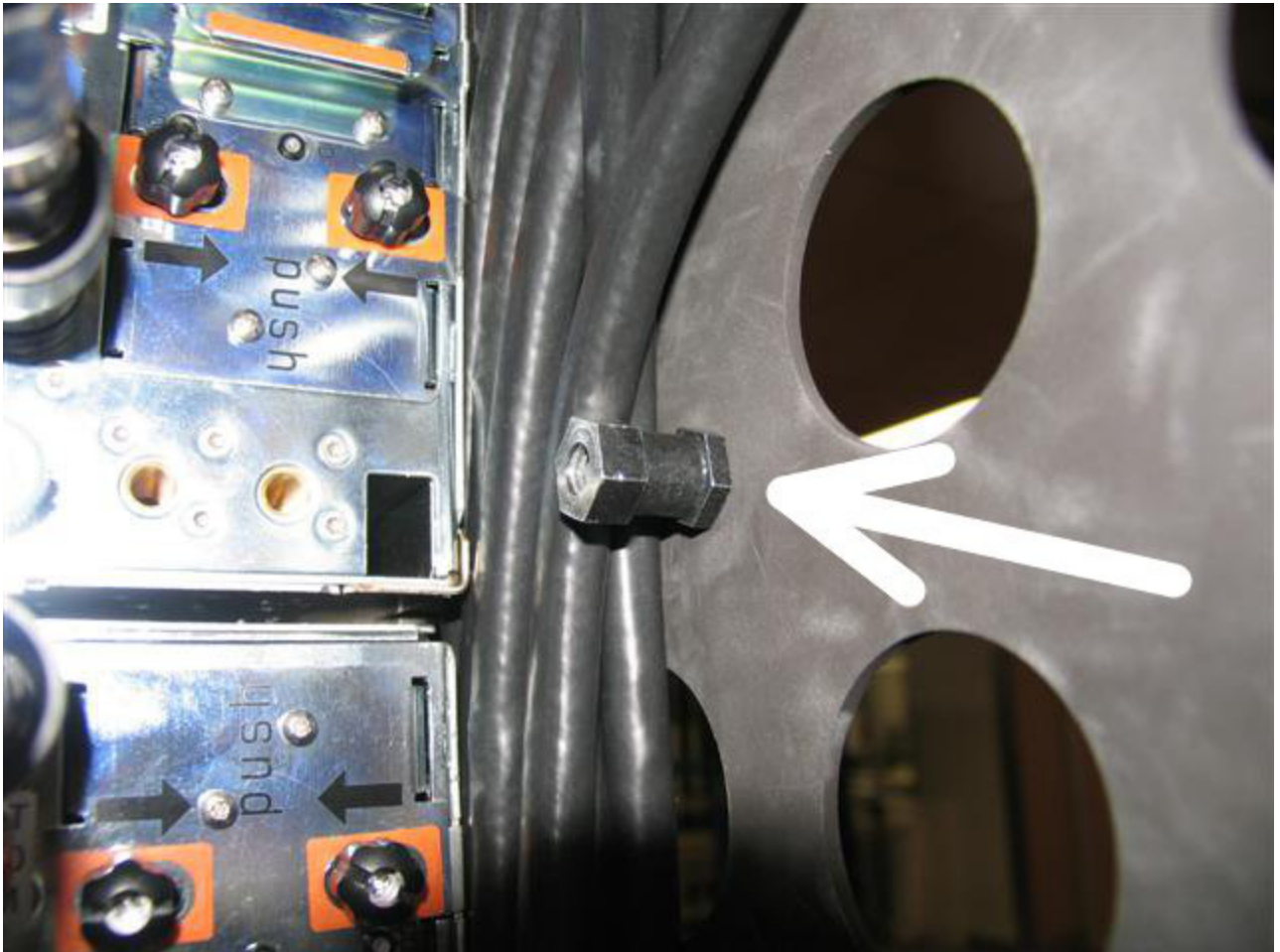
**Figure 20 HPIC Raceway Removal**

34. If replacing BPE-A, then the medium HPIC raceway which manages cables for CEC Drawer positions U.13, U.15, U.17, & U.19 can now be pulled forward and removed similar to Step 33 above (reference Figure 4 above for CEC locations). This will provide access to the front-left BPE mounting bracket.
35. The front-left BPE mounting bracket must now be removed. Using ratchet 6428140, extension 46K2707, and 5mm hex bit 74Y0986, loosen the captive screws, and remove the front-left BPE mounting bracket (see Figure 21 below).
36. Similarly remove front-right BPE retention bracket using ratchet 6428140, extension 46K2707, and 5mm hex bit 74Y0986. Loosen the captive screws and remove the front-right BPE mounting bracket.



**Figure 21 Front-left BPE Mounting Bracket**

37. If replacing BPE-A, then the long raceway containing cables for CEC Drawer positions U.5, U.7, U.9, & U.11 can now be slid forward and removed (reference Figure 4 above for CEC locations). This raceway fully populated with cables can weigh up to 12 lbs.
38. If replacing BPE-A, then move the UEPO Panel down from temporary service/shipping location to the normal position using 4mm hex driver 41V1059 (essentially per Steps 23 to 21 above).
39. Using 16mm socket 5497588, remove the front-right and front-left mounting standoffs from the rack (see photo in Figure 22 below)



**Figure 22 Front-right Mounting Standoff**

40. If replacing upper BPE-B, then Velcro all the BPCH-B and BPD-B cables to the CEC Drawers similar to as shown in Figure 23 below for larger configurations or below for smaller configurations..



**Figure 23 BPE-B Cables Dressed/Secured Clear of Lift Tool (Larger configuration)**

41. Unplug the left and right supply & return water hoses from the BPE
42. Drain water out of the old BPE by performing Appendix D: Power775 Bulk Power Enclosure (BPE) Drain Procedure starting on page 106 of this PDF.
43. Loosen the captive screws for the BPD, BPCH, & front BPRs until the screws retract using 4mm hex driver 74Y0984 (reference Figure 4 & Figure 8 above for FRU locations). Use ladder and/or step stool as required.
44. Unplug front cooling hoses on the left and right sides of the BPD and front BPRs by pulling the coupling sleeve with thumb & forefinger.
45. Unseat and pull out the BPD, BPCH, and front BPRs about 50mm (or 2 inches) each.

46. Attach Lift Tool (P/N 74Y1087) to front of rack (see Figure 24 thru Figure 29 and Steps A) thru F) below for general Lift Tool description and set up)

**The Lift Tool is NOT designed to be used as a cart to move parts or as a step stool and should never be used for those purposes!**

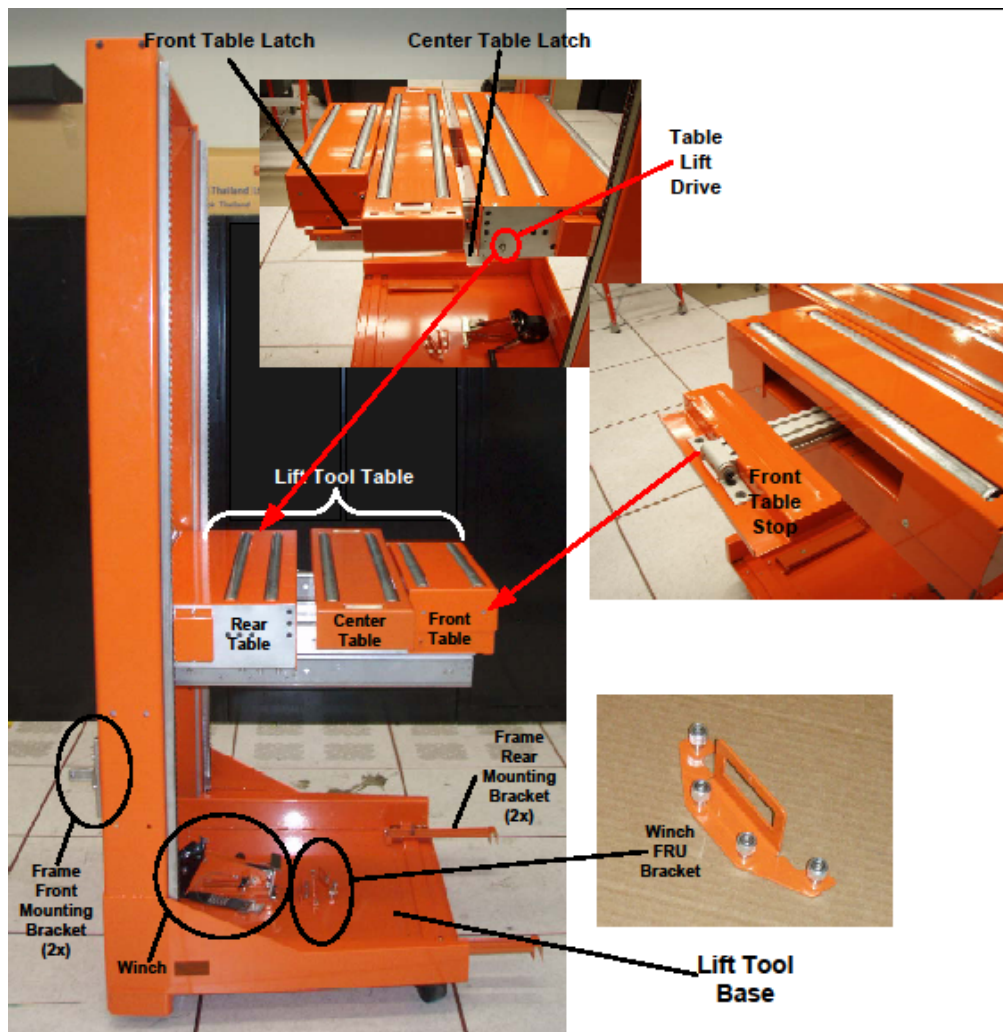


Figure 24 Lift Tool Components (Do not move Lift Tool in this state)

**Front Table Latch:** Latches the Front Table section of the Lift Tool Table.

**Center Table Latch:** Latches the Center Table section of the Lift Tool Table.

**Table Lift Drive:** Rotated to lift and lower the Lift Tool Table

**Lift Tool Table:** Portion of the Lift Tool that supports the FRUs. The table moves up and down in the Lift Tool via the Table Lift Drive

**Frame Front Mounting Brackets:** Used to attach the Lift Tool to the front of the rack.

**Frame Rear Mounting Brackets:** Used to attach the Lift Tool to the rear of the rack

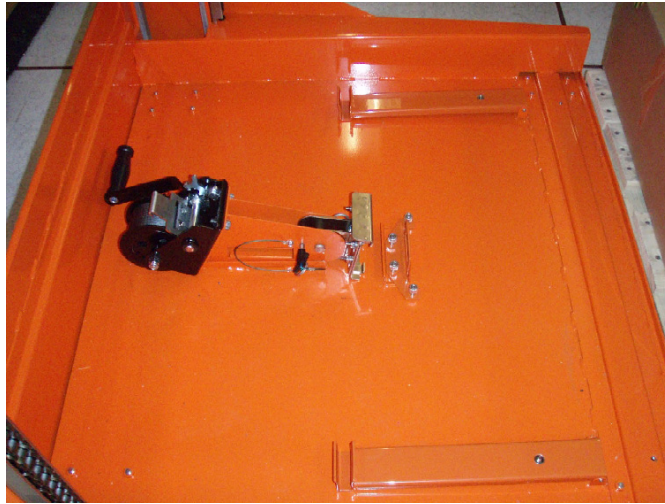
**Winch:** Provided with the Lift tool and used to move FRU's both on and off the Lift Tool Table.

**Winch FRU Bracket:** (Only one of 2 brackets are shown here.) There will be one for the CEC Drawer and one for the Disk Enclosure. These brackets are attached to the FRU. The winch hook is then attached to the bracket.

**Front Table Stop:** Prevent FRU from rolling off the table

**Preparing Lift Tool To Be Moved**

- A) Ensure that the Winch and Winch Bracket are located in their proper positions in the base of the Lift Tool.



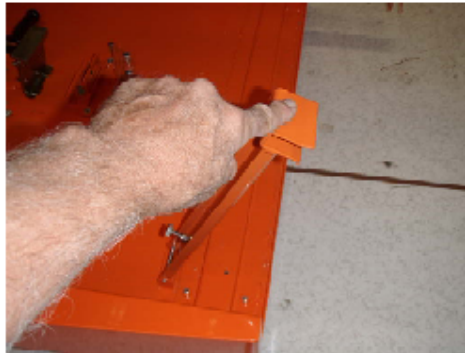
**Figure 25 Lift Tool Winch & Winch Bracket**

- B) Remove any items other than the Winch and Winch Brackets from the base of the Lift Tool. Fold both “Frame Rear Mounting Brackets” onto Lift Tool base. (One of the 2 is shown below)

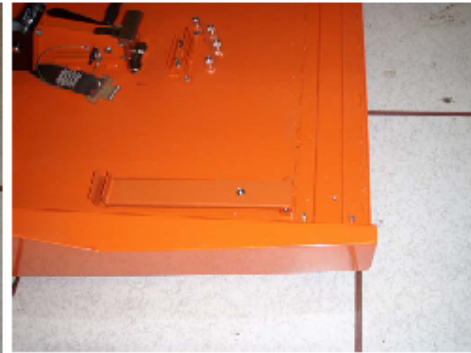
**(1)**



**(2)**



**(3)**



**Figure 26 Frame Rear Mounting Bracket**

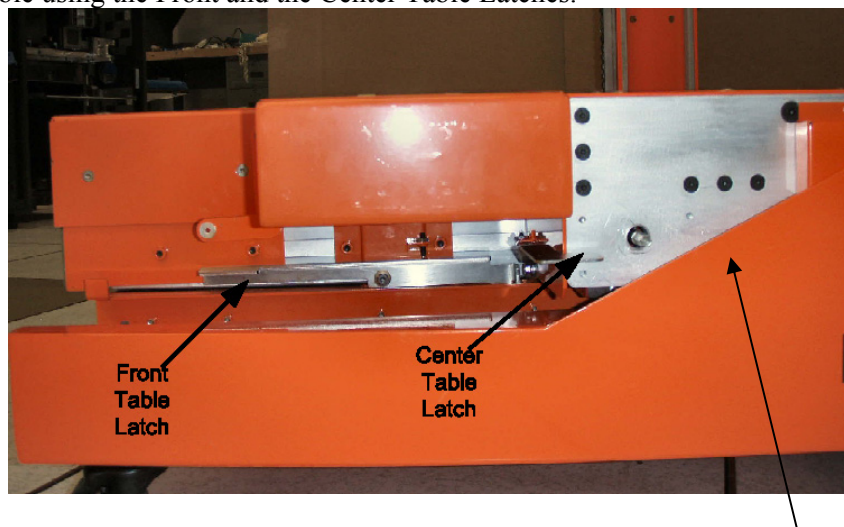
- C) Fold both “Frame Front Mounting Brackets” so they do not extend out (One of the 2 is shown below)





**Figure 27 Frame Front Mounting Bracket**

- D) Close table using the Front and the Center Table Latches.



**Figure 28 Front & Center Table Latches**

- E) Close Front Table Stop and slide it into the Table. Gearbox Drive Shaft

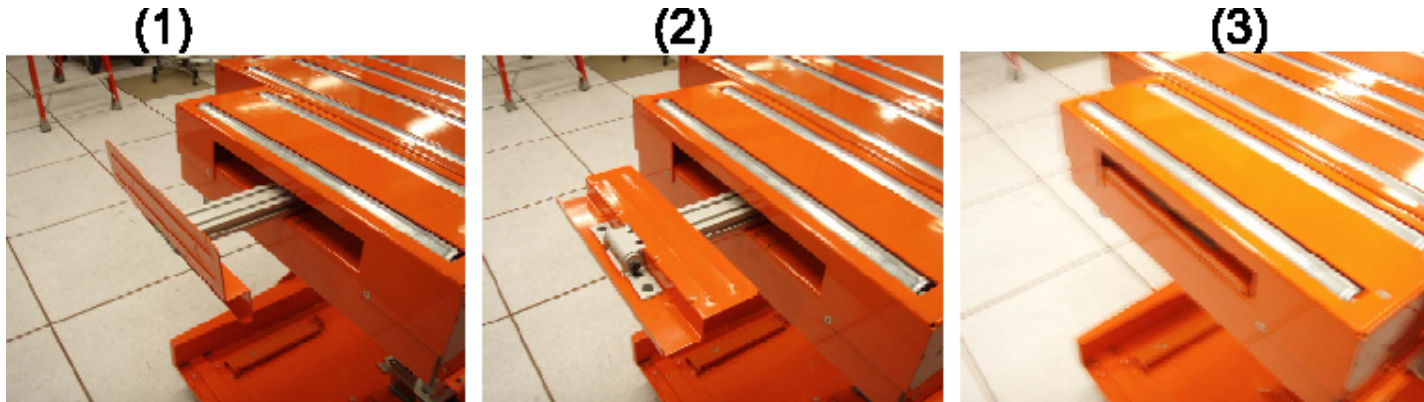


Figure 29 Front Table Stop

F) Lower Table to lowest position. The Lift Tool is now configured to be moved.

***Note: The Lift Tool is not to be used as a cart to transport parts or as a stool!***

47. Secure Lift Tool left & right frame front mounting brackets to front rack members using a 6mm hex bit and ratchet 6428140 (see Figure 30 Lift Tool Mounting Bracket Attachment below). Open the Lift Tool Table Stop and raise it to the UP position, but do not extend the main table outward at this time.

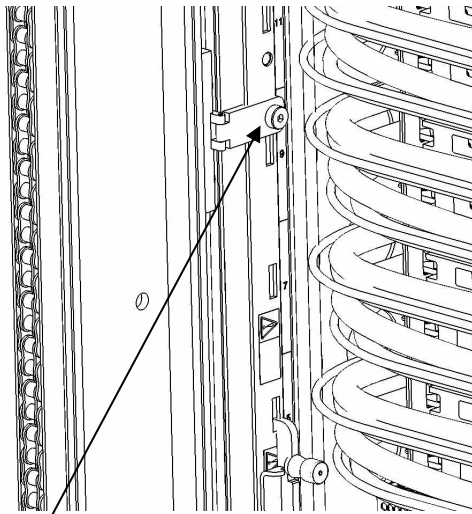
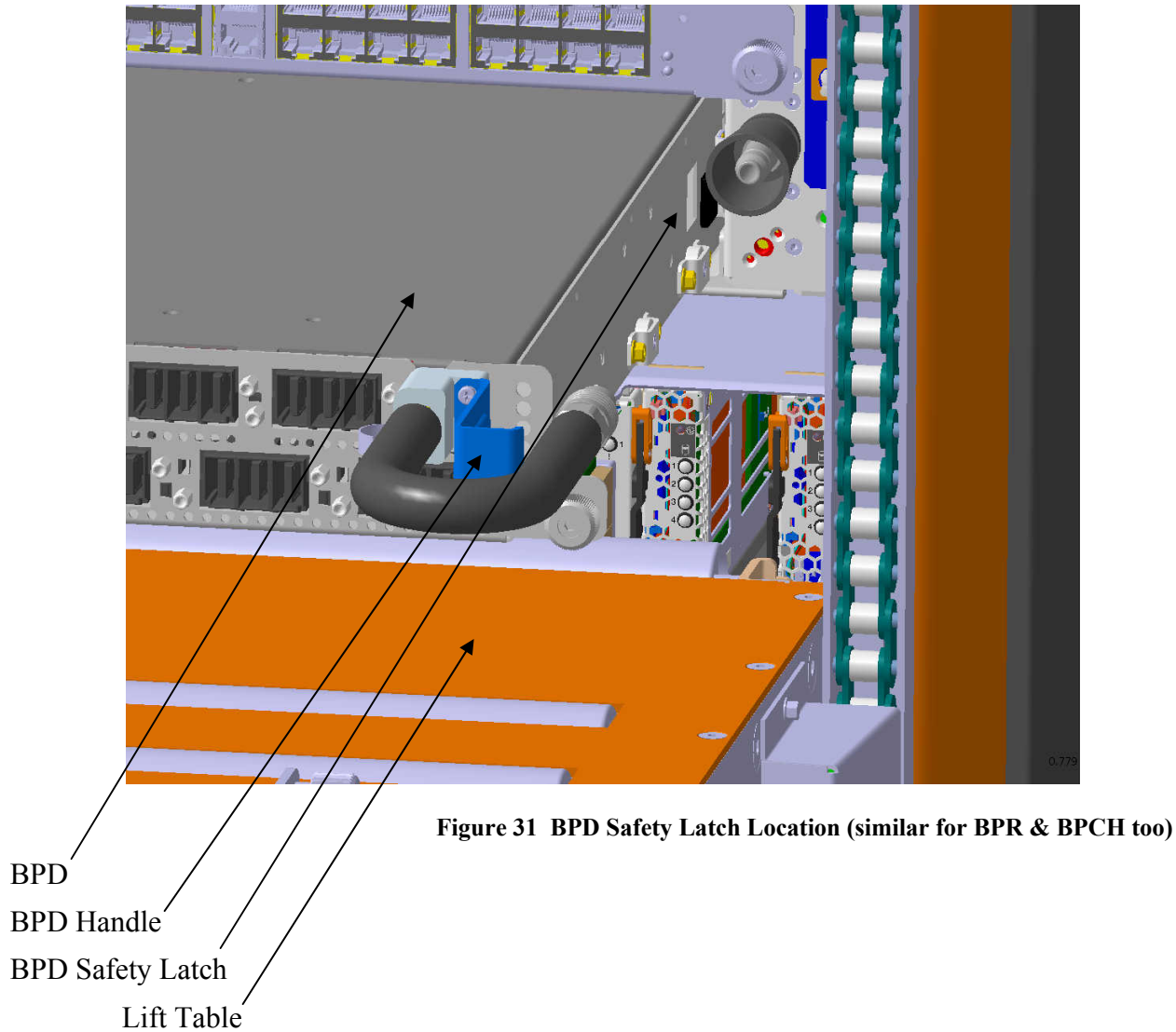


Figure 30 Lift Tool Mounting Bracket Attachment

Lift tool left front mounting bracket

48. Raise Lift Tool table using power driver 74Y0981 (or equivalent), 5/16 inch or 8mm socket, and 1/4 inch socket wrench drive adapter. Engage driver with socket to gearbox drive shaft and raise table to a little below the bottom of the BPD while carefully watching not to snag any HPIC/UPIC cables in front of the CEC Drawers and/or Disk Enclosures!

49. Pull BPD out by the handles until the safety latch on the right side of the unit engages (see Figure 31 below).

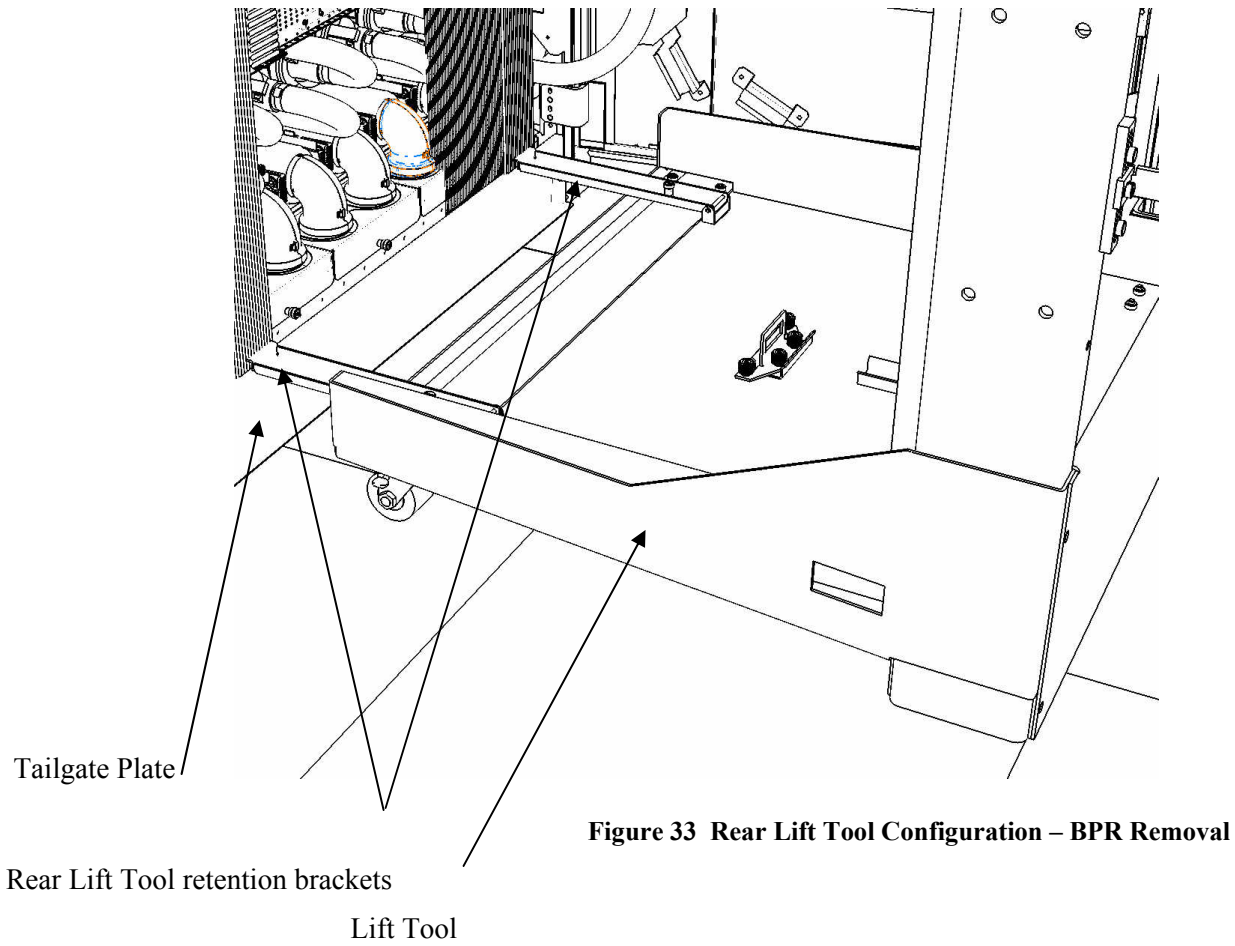


50. Raise the Lift Tool Table any final distance until it is nearly touching the BPD.
51. Ensure the Lift Tool Table Stop is in the UP position.
52. Depress the BPD Safety Latch and simultaneously pull the BPD to disengage it. Remove the BPD fully onto the Lift Table (reference Figure 31 above).
53. Hand-tighten the “BPR Strap” onto the BPD similar to Figure 32 below.



**Figure 32 BPR Safety Strap Attached to BPR (similar for BPD also)**

54. Lower the Lift Tool table while carefully watching not to snag any HPIC/UPIC cables in front of the CEC Drawers and/or Disk Enclosures! Remove BPD from Lift Tool and move to a suitable cart or storage container.
55. Repeat the above Steps 48 to 54 similarly for the BPCH and all front BPRs.
56. Remove any front BPR dummy filler plates if both front BPR slots were not populated.
57. Go to the rear of the rack where the Rear Door Heat Exchanger (RDHX) should still be open.
58. Loosen the captive screws for the rear BPRs until the screws retract using 4mm hex driver 74Y0984 (reference Figure 8 above for BPR locations). Use ladder and/or step stool as required.
59. Unplug cooling hoses on the left and right sides of the rear BPRs by pulling the coupling sleeve with thumb & forefinger.
60. Unseat and pull out the rear BPRs about 50mm (or 2 inches) each.
61. Move Lift Tool to the rear and attach to rack. When servicing BPR's in the rear, the Lift Tool must be used. Unlike frontal applications of the Lift Tool, the mast portion of the tool will not be bolted to the rack. Instead the table will face the rack and the rear Lift Tool retention brackets will pivot out and engage to the tailgate face plate (see Figure 33 Rear Lift Tool Configuration – BPR Removal below).

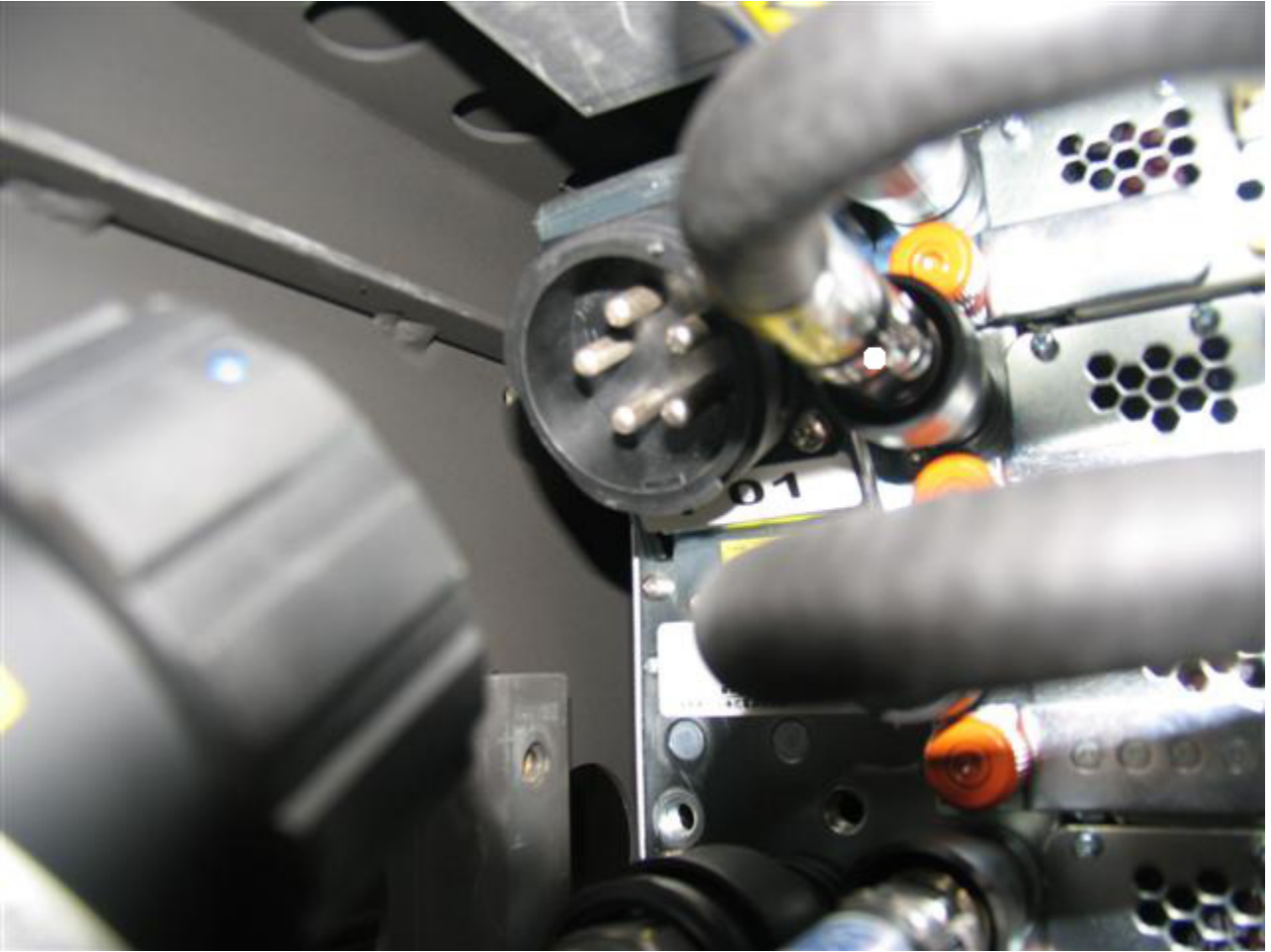


62. Engage rear safety stop rod on the back of the table to prevent the BPRs from rolling off of the table (see Figure 34 below)



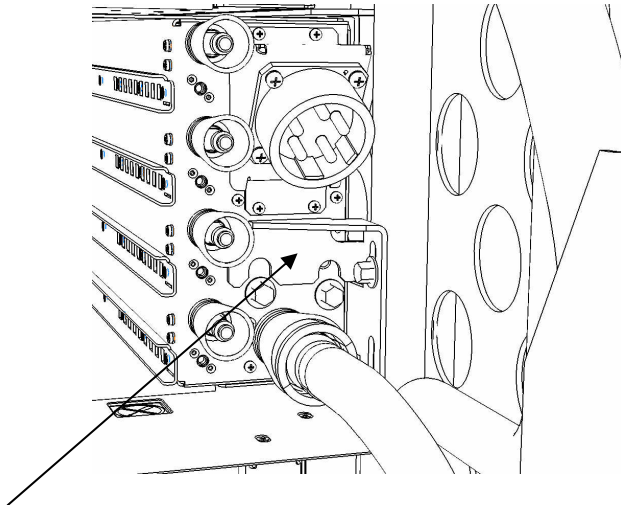
**Figure 34 Lift Tool Rear Safety Stop Rod**

- 63.** Repeat steps Steps 48 to 54 to extract the rear BPR's.
- 64.** Remove any rear BPR dummy filler plates if not all rear BPR slots are populated.
- 65.** Remove Lift Tool from the rear of the rack
- 66.** Disconnect and unplug the left & right Power Cords/Flexible Power Cables from the correct U-P2-T01 and U-P2-T02 –or– U-P1-T01, and U-P1-T02 BPE input connectors (where U is the MTMS 9125 F2C Serial #) by rotating the connector counter-clockwise until it stops and then unplugging the cord/cable connectors (reference Figure 57 below)



**Figure 35 T01 Power Cord/Flexible Power Cable Service**

67. Loosen bolts for rear-left & rear-right BPE retention brackets using 10mm socket 02F3582 and ratchet 6428140. Use extension if needed. Shift bracket upward and temporarily secure bracket in the up position (see Figure 36 Rear-right Retention Bracket below).



**Figure 36 Rear-right Retention Bracket**

Retention Bracket

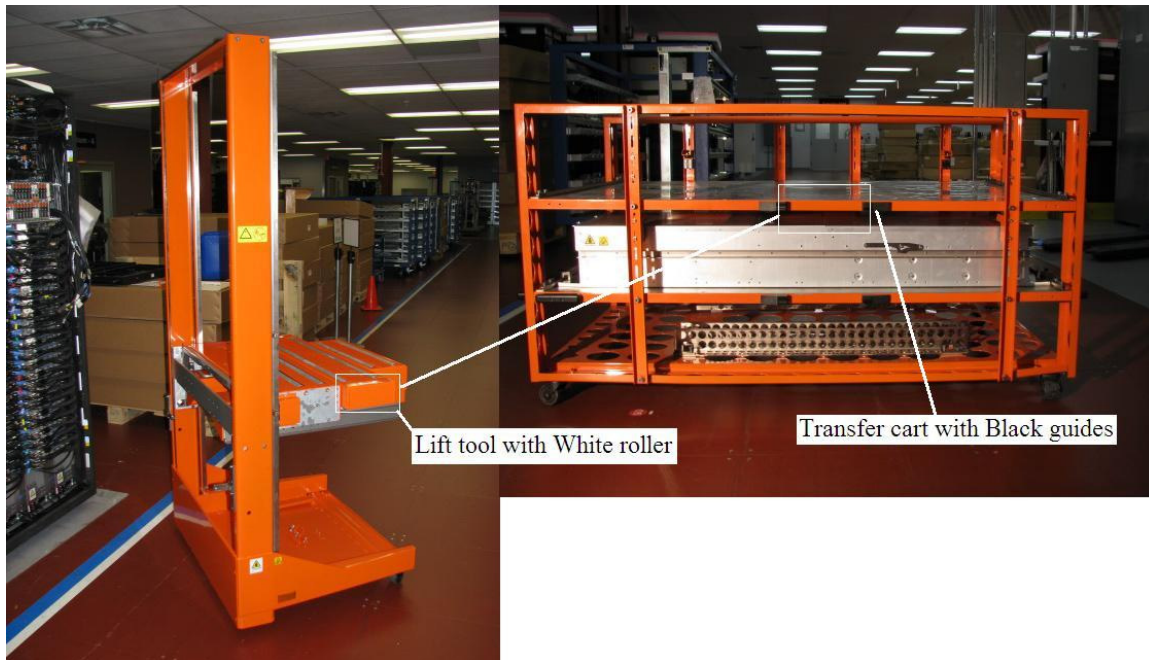
68. The BPE is now ready for extraction from the front. Partially extract the unit so the front face of the BPE is protruding from the front of the rack approximately 100mm / 4 inches. Extreme care must be taken to avoid contact with HPIC and communications cables going to the upper BPE on the right. Lower unit may need to be shifted to the left to avoid these cables. Right side cables may need to be shifted slightly to clear the lower chassis. A SSR may push the lower BPE from the rear while another ensures no cable contact in the front. Only extract the BPE partially at this time.
69. Attach Lift Tool to the front of the rack per Step 47
70. Raise lift table per Step 48 to the base of the lower BPE until the table roller touches the bottom of the BPE while carefully watching not to snag any cables on the rear of the CEC Drawers and/or Disk Enclosures! Open the Lift Tool Table stop and extend the main table sections by releasing the corresponding two latches.
71. Extract the BPE being careful to stay centered between the two outside edge rollers on the Lift Tool Table.
72. Lower the lift tool table so that the table top is at the same height as the unoccupied shelf of the transfer cart.
73. Remove transfer cart guard rails. Using 5 mm Hex tool P/N 74Y0986 (shipped in the Hand Tool Kit) remove the eight screws that retain the transfer cart guard rails (see Figure 37).



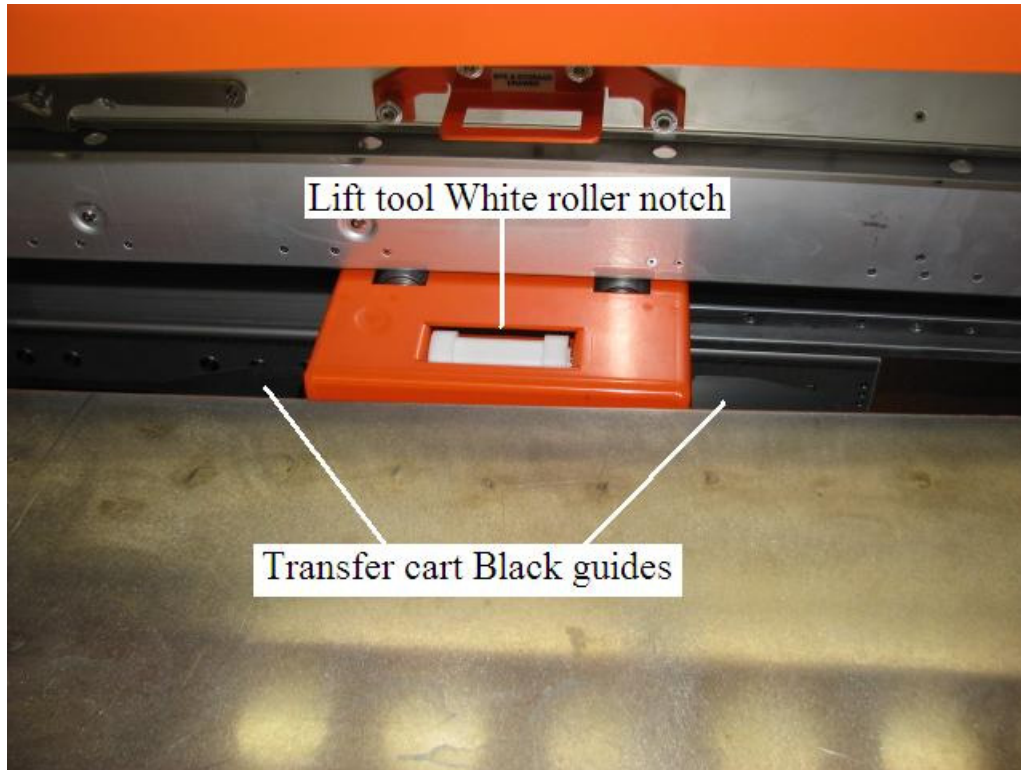


**Figure 37 Remove transfer cart guard rails**

74. Position the transfer cart to the left side of the lift tool. The black guides on the transfer cart should be on either side of the white roller of on the lift tool (see **Figure 38** and **Figure 39**). There is also a latch on the lift tool upright that connects to the transfer cart.

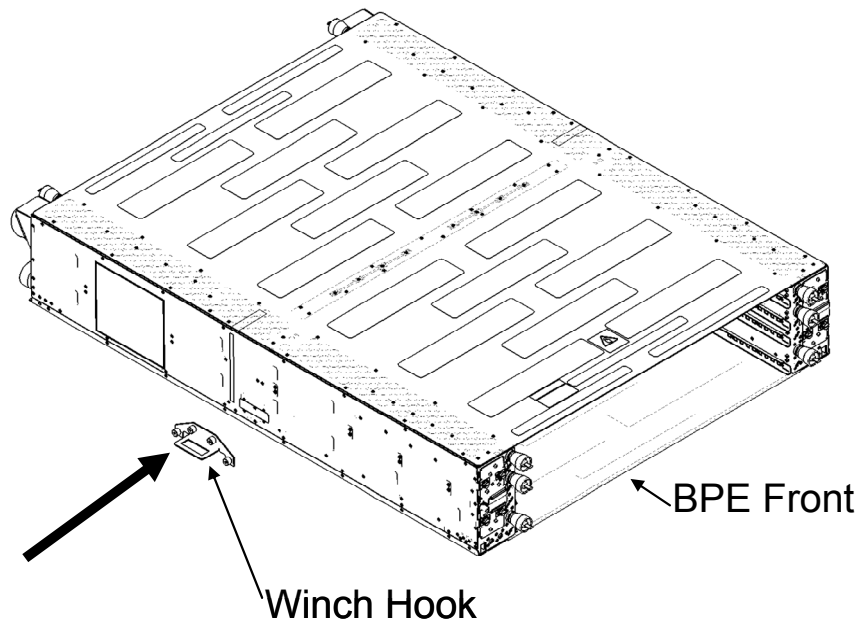


**Figure 38 Lift tool showing white roller engagement area and the transfer cart black rubber guides**



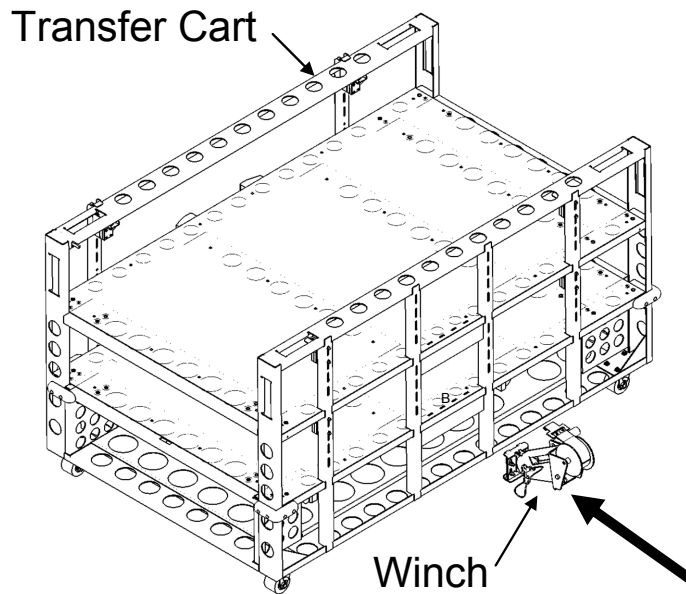
**Figure 39** Transfer cart coupled to lift tool

75. Attach winch hook to defective BPE. Locate the winch hook in the base of the lift tool and attach it to the left side of the defective BPE when looking at the system from the front (see **Figure 40**). There are 2 winch hooks in the base of the lift tool. Use the winch hook that says BPE and storage drawer. The tools required are the 5 mm Hex tool P/N 74Y0986 and Ratchet handle P/N 6428240, (both shipped in the Hand Tool Kit).



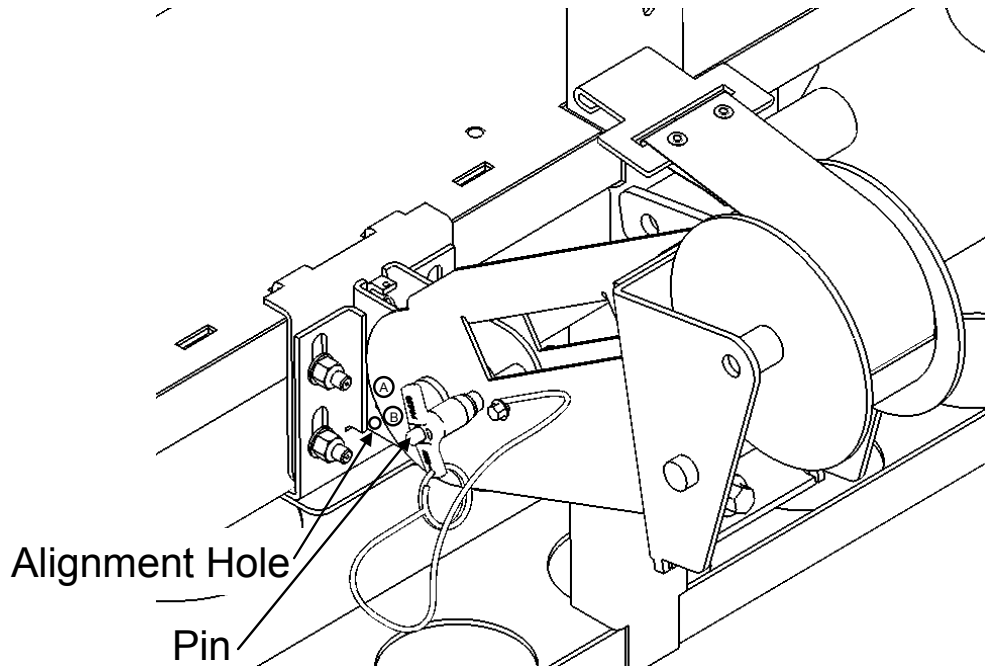
**Figure 40 Attach winch hook**

76. Attach the winch to the transfer cart. The winch is located in the base of the lift tool. Position the winch in mounting position "B" on the empty shelf of the transfer cart (see **Figure 41**).



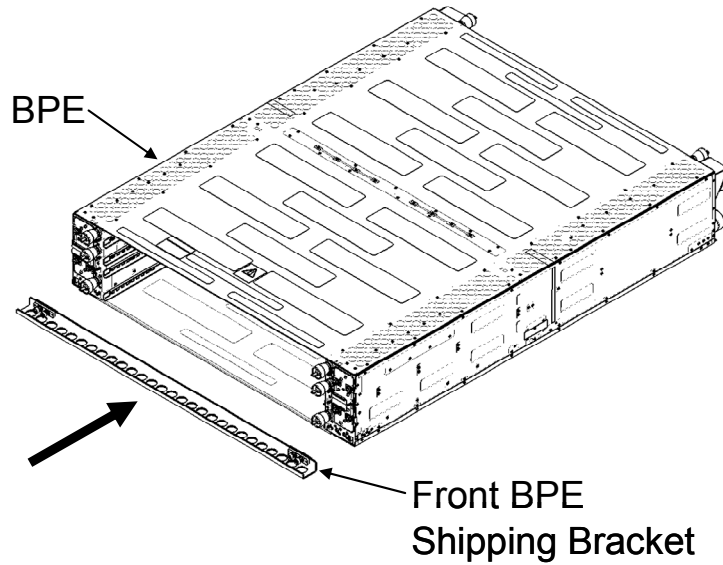
**Figure 41 Attach winch to transfer cart**

77. Adjust the winch angle. Set the winch angle to position “B” removing the pin from the winch body and rotating the winch until the “B” is aligned with the alignment hole (see **Figure 42**). Then insert the pin.



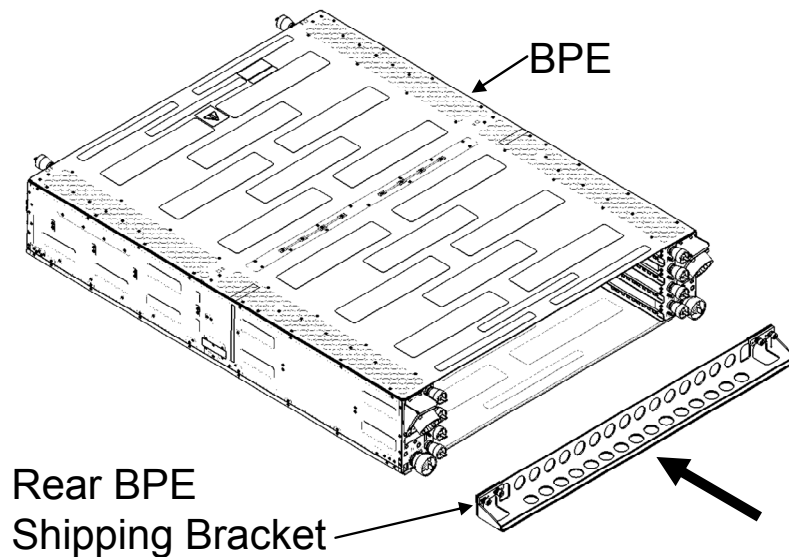
**Figure 42 Set winch angle**

78. Attach the BPE front shipping bracket. The BPE front (86Y0219) shipping bracket is stored in the base of the transfer cart. Mount the BPE front bracket to the front of the BPE (see **Figure 43**). The tools required are the 5 mm Hex tool P/N 74Y0986 and Ratchet handle P/N 6428240, (both shipped in the Hand Tool Kit).



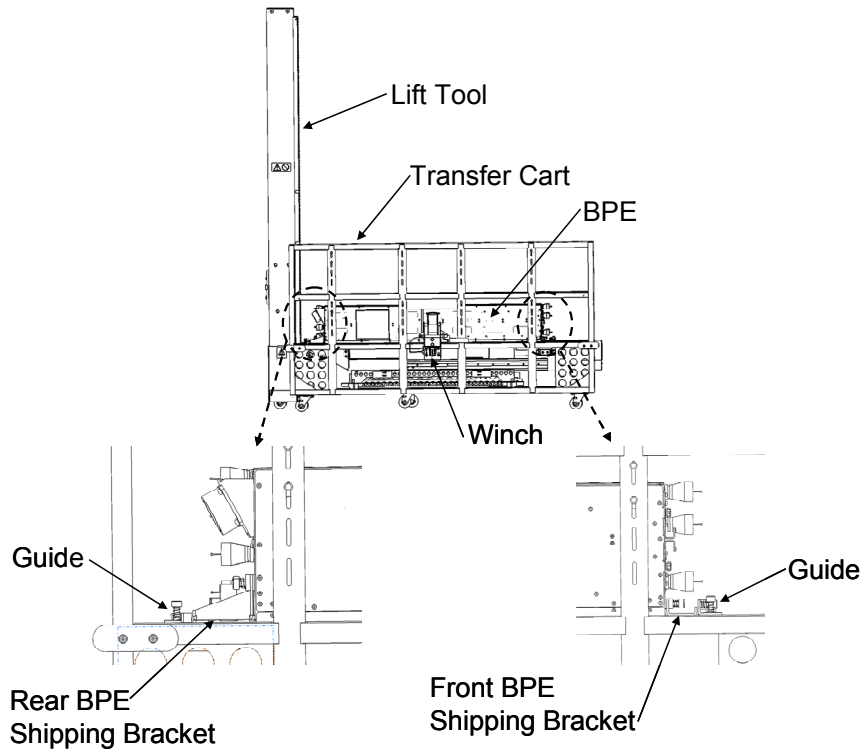
**Figure 43 Mount BPE Front shipping bracket**

79. Attach the BPE rear shipping bracket. The BPE rear (86Y0223) shipping bracket is stored in the base of the transfer cart. Mount the BPE Rear bracket to the rear of the BPE (see **Figure 44**). The tools required are the 5 mm Hex tool P/N 74Y0986 and Ratchet handle P/N 6428240, (both shipped in the Hand Tool Kit).



**Figure 44 Mount BPE Rear shipping bracket**

80. Pull the damaged BPE onto the transfer cart. Attach the winch strap to the winch hook on the BPE. Make sure the BPE front and rear shipping brackets are aligned with the guides on the transfer cart (see **Figure 45**). Slowly use the winch to pull the BPE onto the transfer cart (see **Figure 46**). Make sure the BPE slides straight onto the cart.

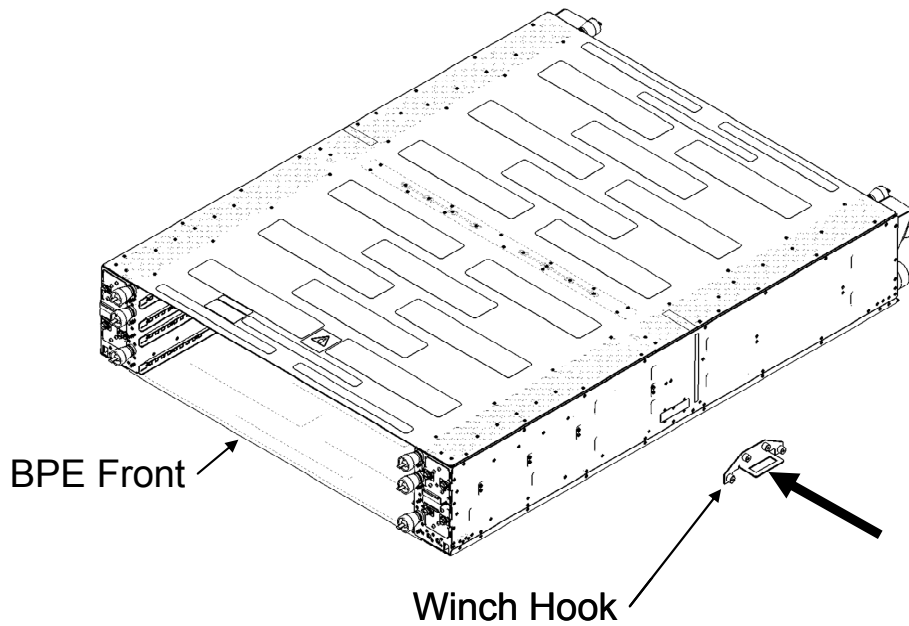


**Figure 45** Align BPE with transfer cart



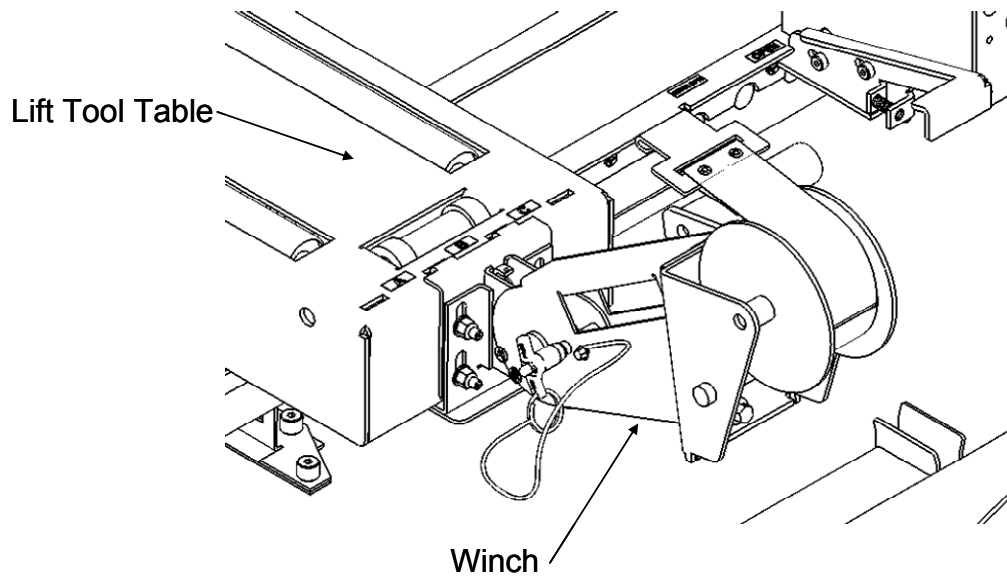
**Figure 46 Use winch to pull BPE onto transfer cart**

81. Disconnect the winch from the transfer cart.
82. Remove the winch hook from the damaged BPE. The tools required are the 5 mm Hex tool P/N 74Y0986 and Ratchet handle P/N 6428240 (both shipped in the Hand Tool Kit).
83. Raise or lower the lift tool table so that the table top is at the same height as the transfer cart shelf which houses the replacement BPE.
84. Attach winch hook to the replacement BPE. Locate the winch hook in the base of the lift tool and attach it to the right side of the defective BPE when looking at the system from the front (see **Figure 47**). There are 2 winch hooks in the base of the lift tool. Use the winch hook that says BPE and storage drawer. The tools required are the 5 mm Hex tool P/N 74Y0986 and Ratchet handle P/N 6428240 (both shipped in the Hand Tool Kit).



**Figure 47 Attach winch hook**

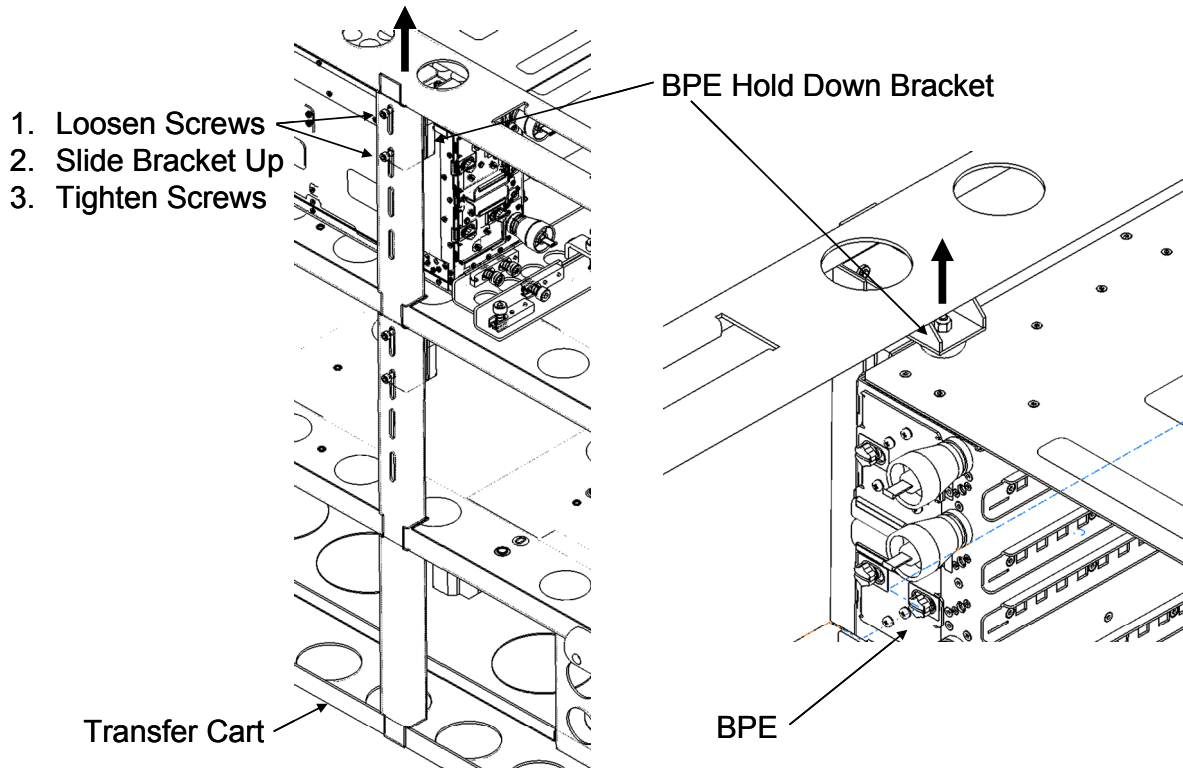
85. Attach the winch to the lift tool table. The winch is located in the base of the lift tool. Position the winch in mounting position “B” on the lift tool table (see **Figure 48**).



**Figure 48 Attach winch to lift tool**

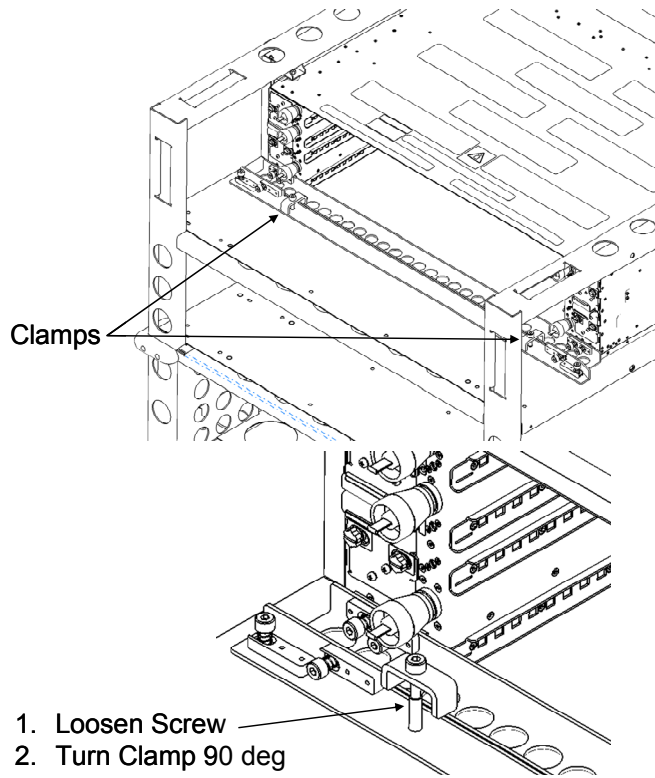
86. Raise the 2 replacement BPE hold down brackets. Using the 4 mm hex driver P/N 74Y0984 shipped in the hand tool kit P/N 74Y0988, move the hold down brackets upwards (see **Figure 49**).





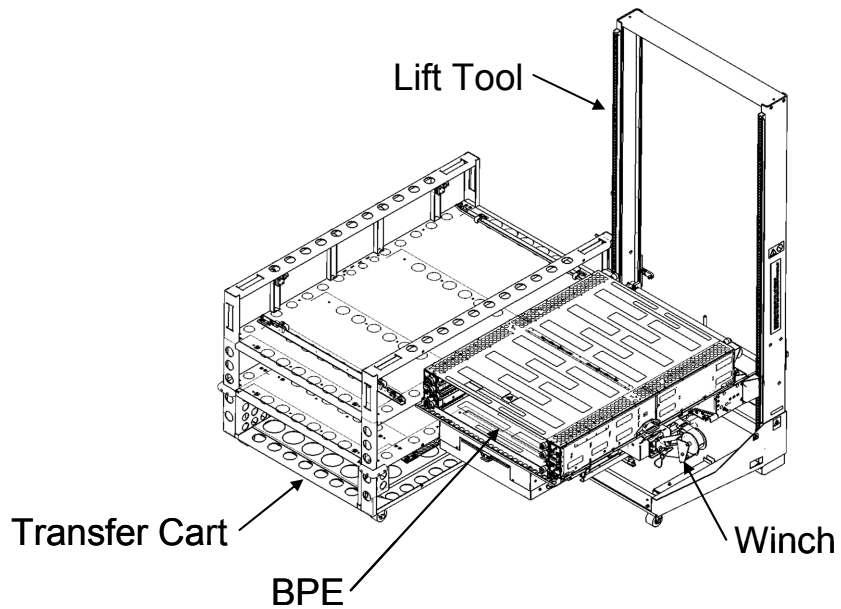
**Figure 49 Raise BPE hold down brackets**

87. Loosen the 4 clamps that secure the BPE shipping brackets to the transfer cart. Loosen the screw on each clamp and then rotate the clamps 90 deg so that they no longer contact the BPE front or rear shipping brackets (see **Figure 50**). The tools required are the 5 mm Hex tool P/N 74Y0986 and Ratchet handle P/N 6428240 (both shipped in the Hand Tool Kit).



**Figure 50 Loosen transfer cart clamps**

88. Pull the replacement BPE onto the lift tool table. Attach the winch strap to the winch hook on the BPE. Slowly use the winch to pull the BPE onto the lift tool table (see **Figure 51**).



**Figure 51 Use winch to pull BPE onto lift tool**

- 89.** Remove the winch hook from the replacement BPE. The tools required are the 5 mm Hex tool P/N 74Y0986 and Ratchet handle P/N 6428240 (both shipped in the Hand Tool Kit).
- 90.** Remove the BPE front shipping bracket. Remove the BPE front bracket from the front of the BPE. The tools required are the 5 mm Hex tool P/N 74Y0986 and Ratchet handle P/N 6428240 (both shipped in the Hand Tool Kit).
- 91.** Remove the BPE rear shipping bracket. Remove the BPE rear bracket from the rear of the BPE. The tools required are the 5 mm Hex tool P/N 74Y0986 and Ratchet handle P/N 6428240 (both shipped in the Hand Tool Kit).
- 92.** Raise the table to the appropriate height and slowly insert the unit into position. Extreme care must be taken to avoid contact with HPIC and communications cables going to the upper BPE-B on the right. Lower BPE-A unit may need to be shifted to the left to avoid these cables. Right side cables may need to be shifted slightly to clear the lower chassis.
- 93.** Insert chassis until fully seated against rear retention brackets. Although the rear brackets have a feature to help center the unit left-to-right, care must be taken to position the unit accurately and to avoid damage to adjacent hoses, drip cups, etc.
- 94.** Lower rear brackets and secure using 10mm socket 02F3582, ratchet 6428140, extension 46K2707, and torque clutch 74Y0985.
- 95.** Install front BPR's, BPD, & BPCH per Steps 54 thru 48.
- 96.** Move Lift Tool to the rear of the rack.
- 97.** Install rear BPR's per Steps 54 thru 48.
- 98.** Connect all BPR and BPD water hoses to the BPE manifolds.
- 99.** Remove lift tool and put it back in the storage location.
- 100.** Pressure Test the new replacement BPE by performing Appendix B: Power775 Bulk Power Enclosure (BPE) Pressure Test Procedure with components starting on page 74 of this PDF.
- 101.** Fill the new replacement BPE with water by performing Appendix C: Power775 Bulk Power Enclosure (BPE) Fill Procedure starting on page 90 of this PDF.
- 102.** Connect rear supply and return hoses to BPE.
- 103.** Move UEPO up to the temporary service position per Step 23.
- 104.** If replacing BPE-A, install the long cable raceway and cables in reverse order per Step 34 and plug CEC cables starting with lowest CEC position. If replacing BPE-A, then the long raceway containing cables for CEC Drawer positions U.5, U.7, U.9, & U.11 can now be reinstalled by sliding it backward into place (reference Figure 4 above for CEC locations). This raceway fully populated with cables can weigh up to 12 lbs.
- 105.** Install front-right BPE retention bracket. Using ratchet 6428140, extension 46K2707, and 5mm hex bit 74Y0986, tighten the captive screws on the BPE mounting bracket.
- 106.** The front-left BPE mounting bracket must now be installed. Using ratchet 6428140, extension 46K2707, and 5mm hex bit 74Y0986, tighten the captive screws on the BPE mounting bracket (see Figure 52 below).

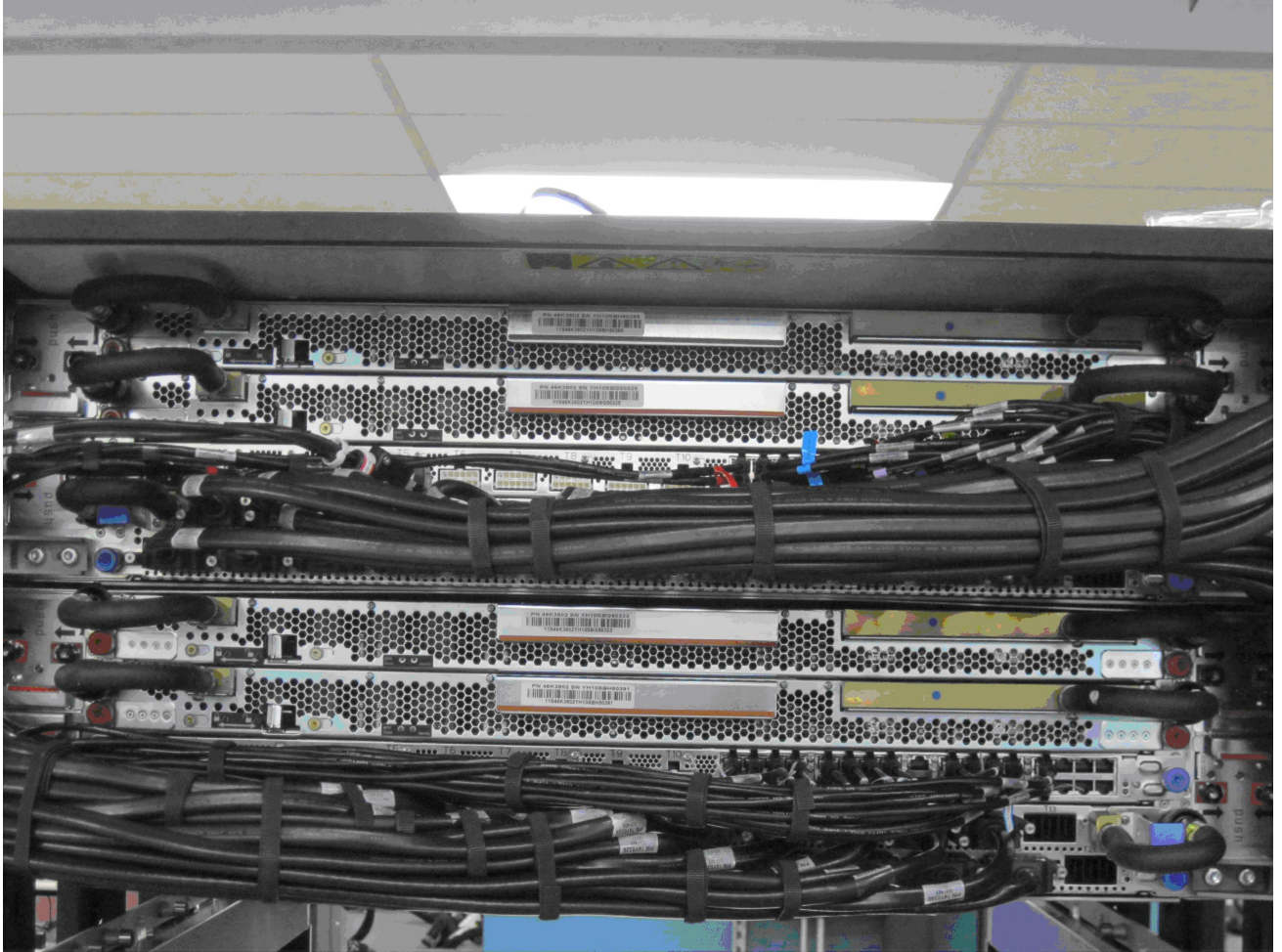


**Figure 52 BPE Mounting Bracket Removal**

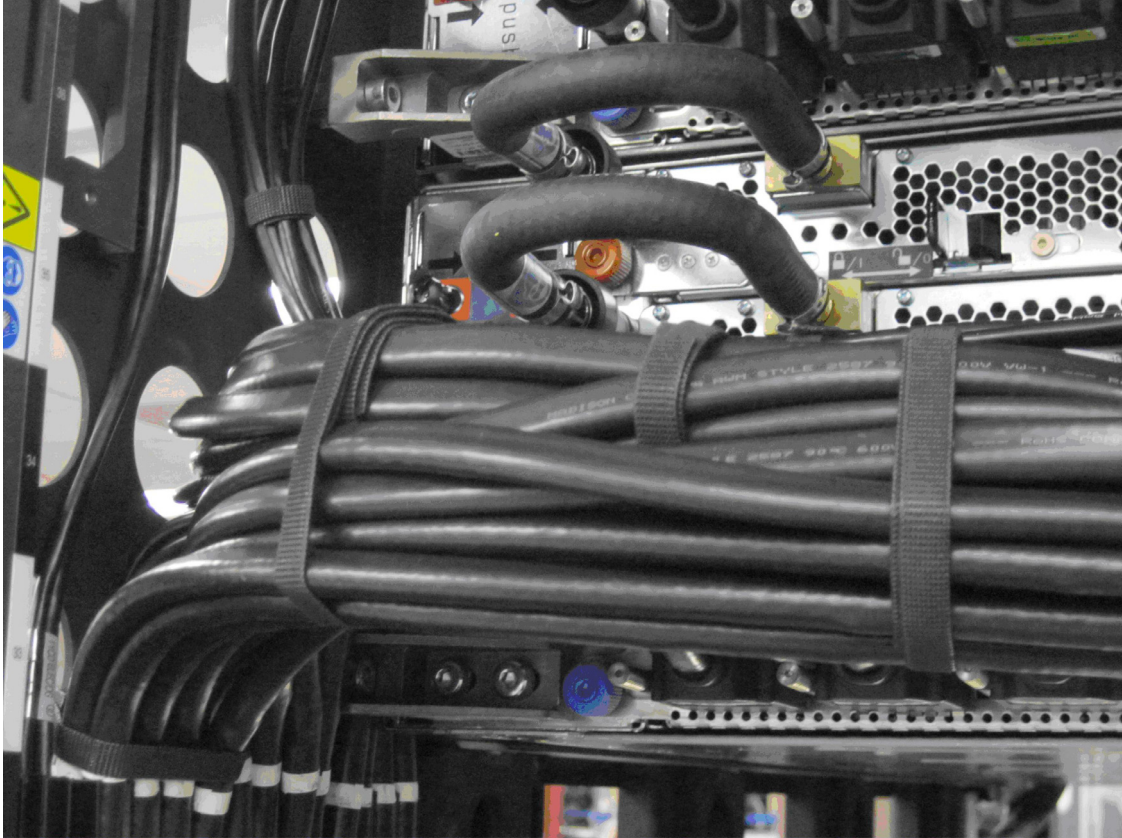
- 107.** If replacing BPE-A, install remaining raceways and cables per Steps 34 to 31 and plug cables from lowest CEC position.

Similar to Step 33, note that the last DCCA Power Cable Raceway to be re-installed has a slight mechanical interference that makes the installation of this cable raceway somewhat challenging. There is a mechanical interference from the side cover of the frame to the shoulder screw that affixes the raceway to the frame. In order to easily slide the last cable raceway into the frame, it may be necessary to slightly pull the side cover away from the body of the frame with your fingers. The mechanical interference is located at the vertical center of the U.27 location in the frame, there is a white label with “27” in black text on the frame at this position. The side cover is tightly fixed to the frame just below the U.27 location, so you will only need to pull back on the side cover by 2-3mm.

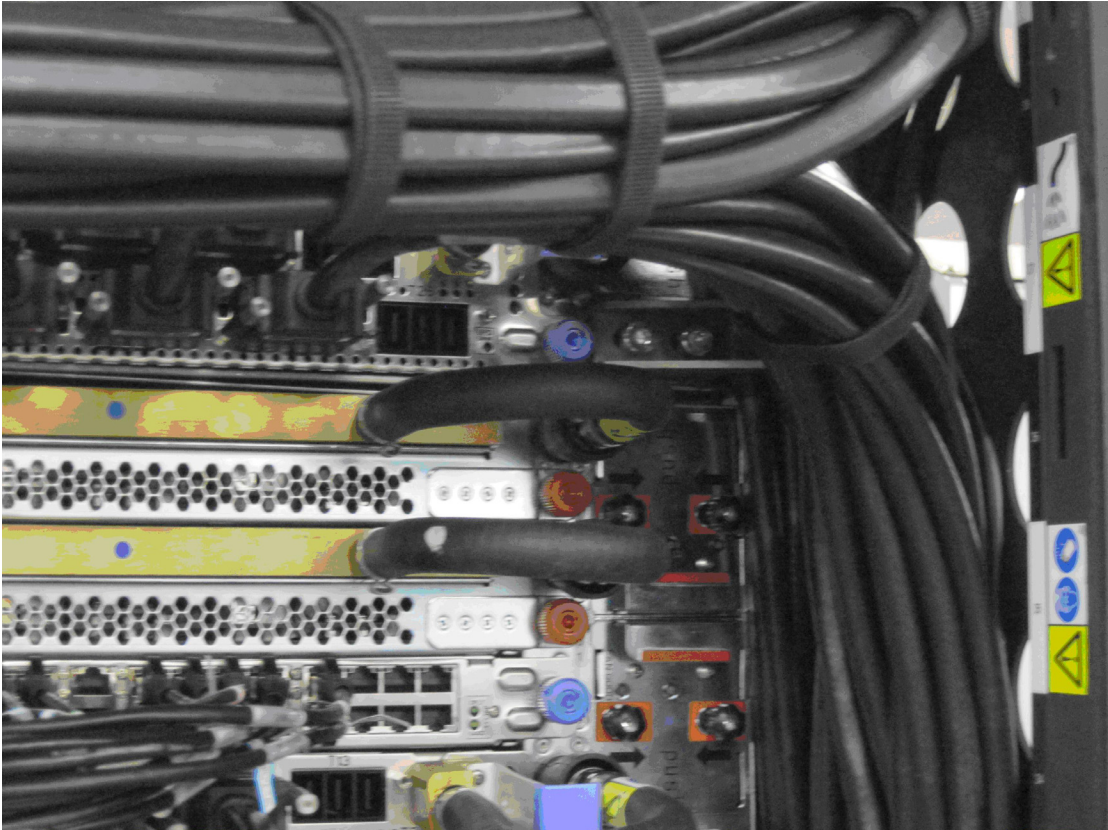
- 108.** Once all cables are connected properly to the BPD and BPCH, the cables must be routed and dressed as originally done. (see Figure 53 thru Figure 56 below for typical cable routing). This is essential to ensure that the front door closes properly and that future service actions are not impeded by incorrectly routed cables.



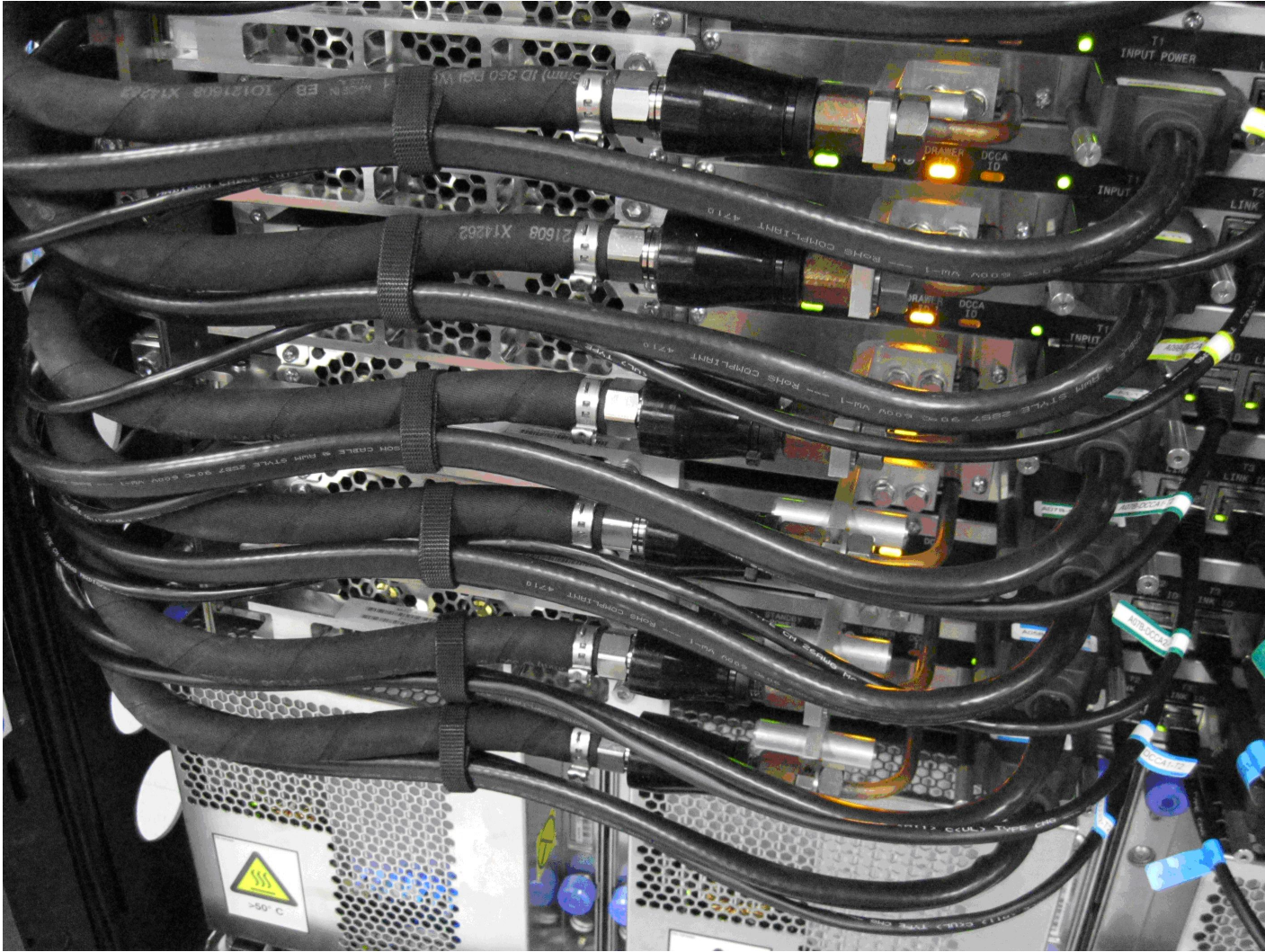
**Figure 53 Proper BPA Cable Routing**



**Figure 54 Proper BPA-A Cable Routing**



**Figure 55 Proper BPA-B Cable Routing**



**Figure 56 Proper CEC Drawer Cable Routing**

- 109.** Use Velcro ties as needed from Velcro puck 31L7174
- 110.** Move UEPO down to the normal position and secure using 4mm hex driver 41V1059.
- 111.** Connect the left & right Power Cords/Flexible Power Cables to the appropriate T01 and T02 connectors by lining up the inner keying tabs, aligning the plug collar pin, and rotating the plug collar clock-wise until locked (reference Figure 57 below). If having difficulty, it can help to have someone hold the bulk wire and take the weight off the connector while you align and plug. Once plugged and latched, pull on the connector to ensure it is not very loose -- which may be an indication the connector is not seated properly.





**Figure 57 T01 Power Cord/Flexible Power Cable Service**

112. Attach front door latch bracket and secure using 4mm hex driver 41V1059.
113. Have the customer or approved delegate turn back on the two branch circuit wall CB's for the corresponding Power Cords/Flexible Power Cables that were turned off earlier. Ensure the LEDs below the corresponding BPE T01 and T02 input connector labels are now lit. Note that you may need to use the ladder or step stool to see the Power Cord LEDs because sometimes they are blocked from sight due to being just above the rear retention brackets.
114. Neatly route the Power Cords/Flexible Power Cables in the frame member trough and resecure the Cable Ties/velcro strips neatly inside the frame.
115. Double-check all water hoses quick connects are latched tight on BOTH BPAs by pulling firmly on the quick connect side of every BPA water hose. Both BPA sides should have their hoses checked this way because any water hose may have inadvertently become unlatched due to nearby service actions.
116. Turn on the BPR slide-switches on all 6 BPRs that in the new BPE and then those same LEDs should start blinking.

- 117.** If replacing BPE-A, reactivate A-side BPRs by sending a BPA-A activate command to the BPCH-A FSP. To do this access the **HMC BPC-A ASM SIDE\_A** Service Processor Command Line (Refer to 'Power775 BPC FSP Command Line Procedure' in Appendix A of this PDF and ensure **ASM SIDE\_A** is active per Step 12 of Appendix A) and enter the following at the command prompt (IMPORTANT: DOUBLE-CHECK THE COMMAND IS TYPED IN EXACTLY CORRECT BEFORE PRESSING ENTER BECAUSE EVEN A SINGLE INCORRECT CHARACTER COULD RESULT IN SEVERE UNINTENDED SYSTEM DISRUPTION!!):

```
bpccmd -c 11aa0000ff01
```

Expect 00aa00 returned which means the command executed properly and reported successful "Activated BPA-A/Cross-Communications Cable" status.

If something different is returned, then contact the next level of support. For reference, the returned "rrssdd" format hexadecimal characters can be translated as follows:

**"rr" Return Code Definitions:**

00 = Command executed properly  
21 = Cage Not Present / Configured  
22 = FRU Not Present / Configured.  
27 = Location code error  
4A = Error in sent command  
4B = Invalid State  
95 = BPCH LIC Detected Error  
96 = Mail-boxing error

**"ss" Sequence Number:**

aa = Arbitrary and unimportant

**"dd" Return Data Definitions**

00 = BPA-A activate successful & associated SRCs cleared. It is OK to continue the service action

- 118.** If replacing BPE-B, reactivate B-side BPRs by sending a BPA-B activate command to the BPCH-B FSP. To do this access the **HMC BPC-B ASM SIDE\_B** Service Processor Command Line (Refer to 'Power775 BPC FSP Command Line Procedure' in Appendix A of this PDF and ensure **ASM SIDE\_B** is active per Step 12 of Appendix A) and enter the following at the command prompt (IMPORTANT: DOUBLE-CHECK THE COMMAND IS TYPED IN EXACTLY CORRECT BEFORE PRESSING ENTER BECAUSE EVEN A SINGLE INCORRECT CHARACTER COULD RESULT IN SEVERE UNINTENDED SYSTEM DISRUPTION!!):

```
bpccmd -c 11aa0000ff01
```

Expect 00aa00 returned which means the command executed properly and reported successful "Activated BPA-B/Cross-Communications Cable" status.

If something different is returned, then contact the next level of support. For reference, the returned “rrssdd” format hexadecimal characters can be translated as follows:

**“rr” Return Code Definitions:**

00 = Command executed properly  
21 = Cage Not Present / Configured  
22 = FRU Not Present / Configured.  
27 = Location code error  
4A = Error in sent command  
4B = Invalid State  
95 = BPCH LIC Detected Error  
96 = Mail-boxing error

**“ss” Sequence Number:**

aa = Arbitrary and unimportant

**“dd” Return Data Definitions**

00 = BPA-B activate successful & associated SRCs cleared. It is OK to continue the service action

**119.** Wait 10 minutes and then ensure all the BPRs have their “BPR Good” LEDs on solid.

**120.** Turn off the UEPO Service Identify LED by accessing the **HMC BPC-A ASM SIDE\_A** Service Processor Command Line (Refer to ‘Power775 BPC FSP Command Line Procedure’ in Appendix A of this PDF and ensure **ASM SIDE\_A** is active per Step 12 of Appendix A) and enter the following at the command prompt (IMPORTANT: DOUBLE-CHECK THE COMMAND IS TYPED IN EXACTLY CORRECT BEFORE PRESSING ENTER BECAUSE EVEN A SINGLE INCORRECT CHARACTER COULD RESULT IN SEVERE UNINTENDED SYSTEM DISRUPTION!!):

```
bpccmd -c 28aa0000ff01
```

Expect 00aa00 returned which means the command executed properly and reported successful “UEPO Service Identify LED Off” status.

If something different is returned, then contact the next level of support. For reference, the returned “rrssdd” format hexadecimal characters can be translated as follows:

**“rr” Return Code Definitions:**

00 = Command executed properly  
21 = Cage Not Present / Configured  
22 = FRU Not Present / Configured.  
27 = Location code error  
4A = Error in sent command  
4B = Invalid State  
95 = BPCH LIC Detected Error  
96 = Mail-boxing error

**“ss” Sequence Number:**

aa = Arbitrary and unimportant

**“dd” Return Data Definitions**

00 = UEPO Service Identify LED turned off successfully. It is OK to continue with the service procedure

- 121.** Confirm the UEPO Panel Service Identify LED is now off.
- 122.** Wait 5 minutes and then perform Steps 123 & 124 to verify the original SRC does NOT reoccur and to confirm the service procedure completed successfully.
- 123.** Issue an BPCH-A real-time Power/Thermal SRC read-out command to the **HMC BPC-A ASM SIDE\_A** Service Processor Command Line (Refer to ‘Power775 BPC FSP Command Line Procedure’ in Appendix A of this PDF and ensure **ASM SIDE\_A** is active per Step 12 of Appendix A) by entering the following at the command prompt (IMPORTANT: DOUBLE-CHECK THE COMMAND IS TYPED IN EXACTLY CORRECT BEFORE PRESSING ENTER BECAUSE EVEN A SINGLE INCORRECT CHARACTER COULD RESULT IN SEVERE UNINTENDED SYSTEM DISRUPTION!!):
- ```
bpccmd -m gi,3,s
```

Verify the original SRC problem is not listed in any of the src.referenceCode fields (there may be multiple fields to check).

- 124.** Issue an BPCH-B real-time Power/Thermal SRC read-out command to the **HMC BPC-B ASM SIDE\_B** Service Processor Command Line (Refer to ‘Power775 BPC FSP Command Line Procedure’ in Appendix A of this PDF and ensure **ASM SIDE\_B** is active per Step 12 of Appendix A) by entering the following at the command prompt (IMPORTANT: DOUBLE-CHECK THE COMMAND IS TYPED IN EXACTLY CORRECT BEFORE PRESSING ENTER BECAUSE EVEN A SINGLE INCORRECT CHARACTER COULD RESULT IN SEVERE UNINTENDED SYSTEM DISRUPTION!!):
- ```
bpccmd -m gi,3,s
```

Verify the original SRC problem is not listed in any of the src.referenceCode fields (there may be multiple fields to check).

- 125.** If any of the src.referenceCode fields list the original SRC that led you to perform this service procedure, then continue with replacing the next item on the FRU call list or contact the next level of support.

- 126.** If the original SRC error has not reoccurred and is now cleared, then reinstall the front door to the rack by aligning the door slightly past 90 degrees open and then lifting it onto the lower hinge pin. Allow the door to drop about halfway onto the lower hinge pin. Next, align the front door on the upper hinge pin. The door should now be fully engaged on both hinge pins. Note: the lower hinge pin is longer than the upper hinge pin, which necessitates installing the door on the lower hinge pin first. Check that the door swings and latches freely. Adjust cable bundles as needed so as not to interfere with the door closing/latching. The front door weighs 37lbs (16.8 kg) (see **Figure 58 Front Door Install**).



**Figure 58 Front Door Install**

- 127.** Close out the HMC Service Focal Point problem as appropriate.
- 128.** If any of the src.referenceCode fields list the original SRC that led you to perform this service procedure, then continue with replacing the next item on the FRU call list or contact the next level of support.

---

### **3.3 End of Power775 Bulk Power Enclosure (BPE) Service Procedure**

## 4 APPENDIX A: POWER775 BPC FSP COMMAND LINE PROCEDURE

### 4.1 Procedure to Access the BPC FSP Command Line

1. The HMC can be accessed via the keyboard/display that resides in the network management rack.
2. Login to the HMC if not done already.
3. In the HMC navigation pane, expand 'Systems Management' + sign and then click 'Frames' (see Figure 59 HMC Frames):

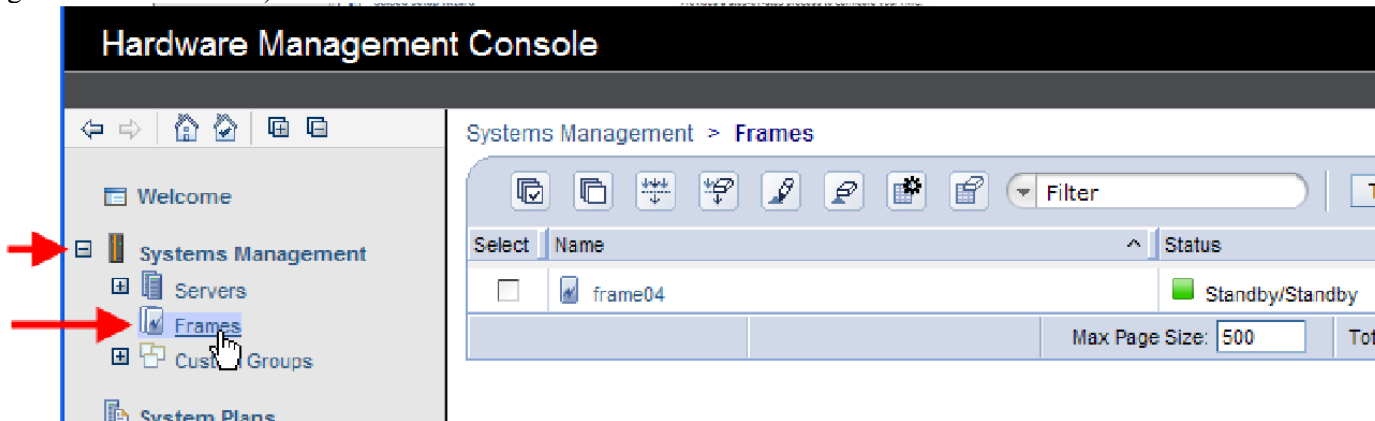


Figure 59 HMC Frames

4. From the Tasks Menu right-arrow pull-down menu, click **Operations → Launch Frame Advanced Systems Management (ASM)** as shown in Figure 60

Systems Management > Frames

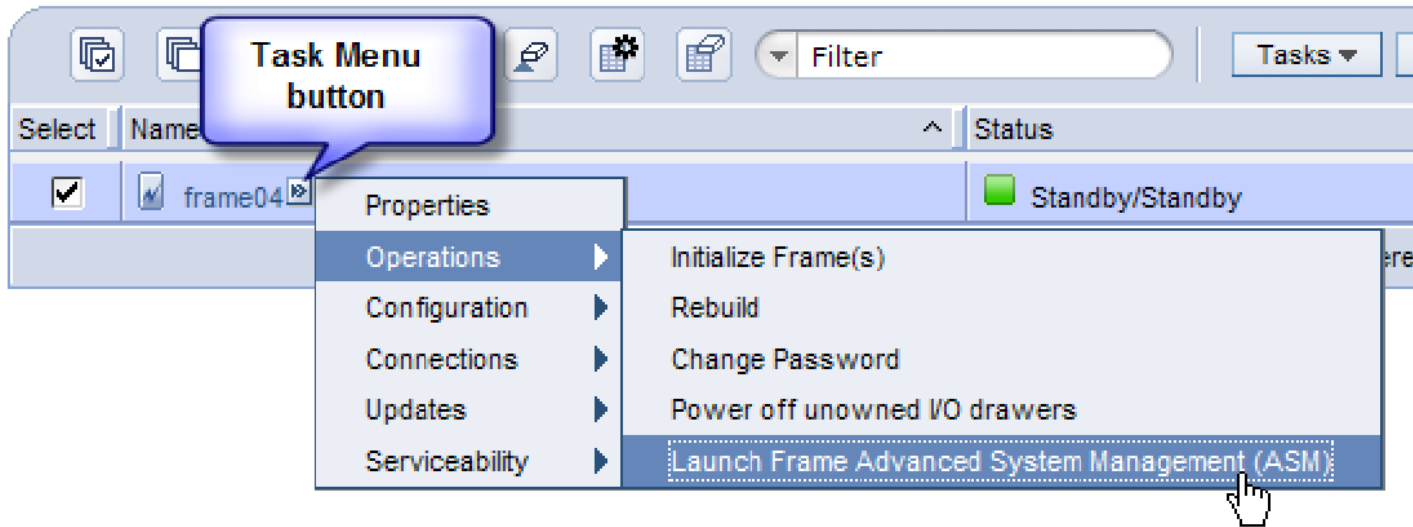


Figure 60 Launch Frame Advanced System Management (ASM)

5. From the Launch ASM Interface window, select **SIDE\_A** or **SIDE\_B** (whichever the instructions call for) from the 'Frame IP Address:' pull-down arrow menu, then click the **OK** button (see Figure 61 which shows the **SIDE\_A** BPC FSP selected)

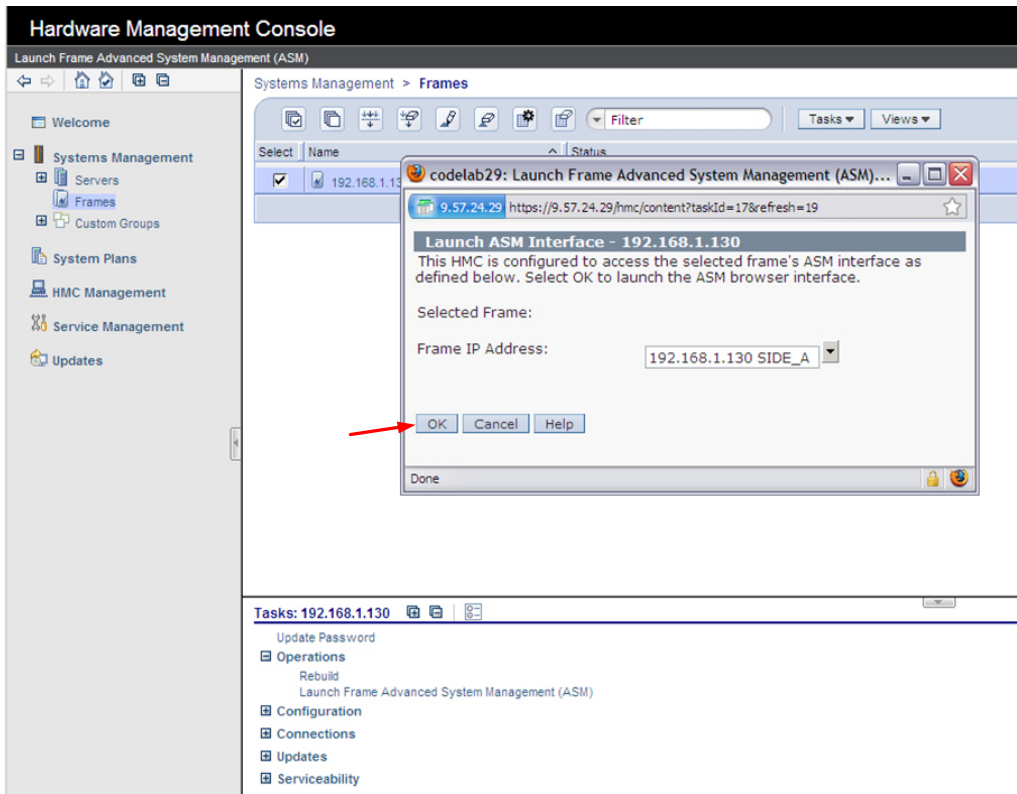


Figure 61 Select BPC FSP SIDE\_A

Power775 Bulk Power Enclosure (BPE) Service Procedure  
---Appendix A: BPC FSP Command Line Procedure ---

6. The ASM login window is presented. Acquire the necessary User ID and Password.  
“celogin” requires Daily PW from the IBM Support Center.  
“celogin1” might be has enabled by the customer. If so, obtain the password from the customer.
7. Enter User ID
8. Enter Password
9. Click **Log in** button

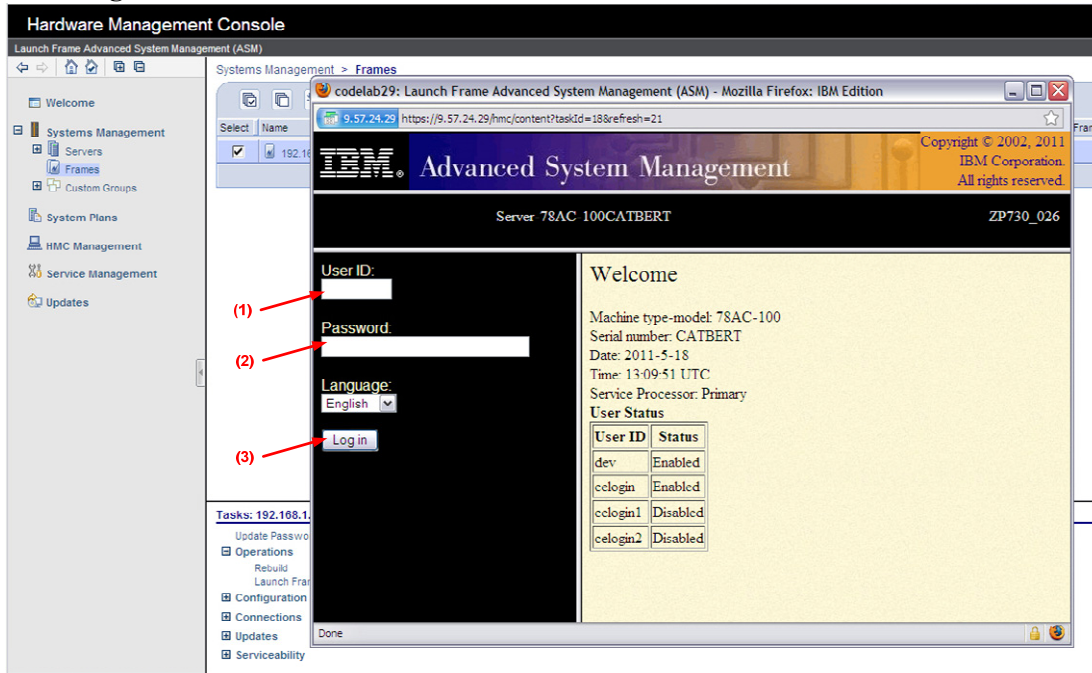


Figure 62 ASM Login

10. Expand ‘System Service Aids’ + sign and Select ‘Service Processor Command Line’ to obtain Figure 63.



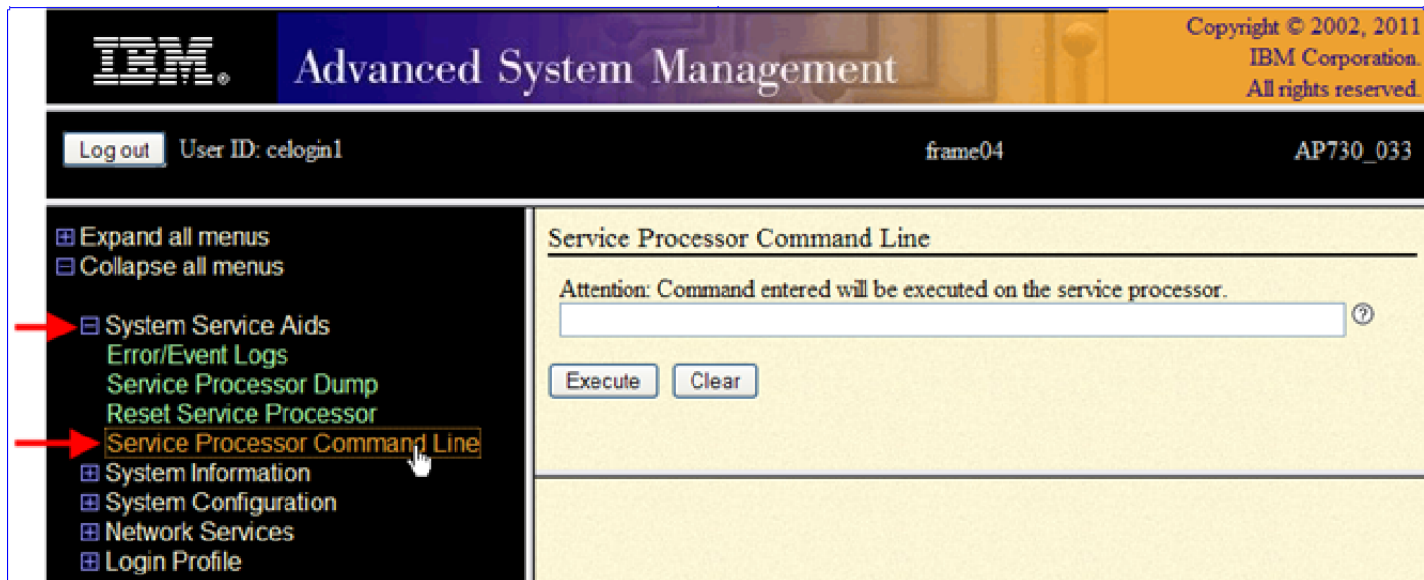


Figure 63 ASM Service Processor Command Line

11. The ASM BPC FSP Command line will be presented. Enter the commands defined in the paper service procedures at this command line and press the Enter key (or click the **Execute** button).
12. If you are not sure whether you are on the ASM **A\_SIDE** or **B\_SIDE** BPC FSP Command Line, then enter the command **bpccmd -m GET\_SIDE** to query which BPC FSP is actively connected.
13. Return to the step of the paper service procedure that directed you to this Appendix A.

---

## 4.2 End of Appendix A: Power775 BPC FSP Command Line Procedure

---

## 5 APPENDIX B: POWER775 BULK POWER ENCLOSURE (BPE) PRESSURE TEST PROCEDURE WITH COMPONENTS

---

### 5.1 Safety Notices

Read “Safety Notices“ available from InfoCenter:

<http://publib.boulder.ibm.com/infocenter/powersys/v3r1m5/topic/p7hdx/G229-9054.pdf>

The following cautions apply to all Power775 service procedures:

**CAUTION:**

**Energy hazard present and Shorting might result in system outage and possible physical injury. Remove all metallic jewelry before servicing. (C001)**

**CAUTION:**

**The doors and covers to the product are to be closed at all times except for service by trained service personnel. All covers must be replaced and doors locked at the conclusion of the service operation. (C013)**

**CAUTION:**

**Service of this product or unit is to be performed by trained service personnel only. (C032)**

The following notices specifically pertain to this Power775 service procedure.

**CAUTION: The water-based coolant solution may contain an additive intended to inhibit corrosion (or provide other functions). The solution may cause irritation to the skin or eyes. Avoid direct contact with the solution. Employ appropriate Personal Protective Equipment when performing operations involving the coolant or which may potentially expose you to the coolant. Refer to the MSDS for more information. (C037)**

**CAUTION: This unit must not be left running unattended, service personnel should always be overseeing the process. (C038)**



**DANGER: Hazardous voltage present. Voltages present constitute a shock hazard, which can cause severe injury or death. (L004)**



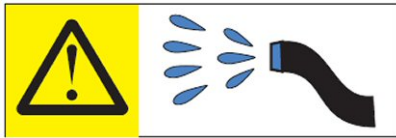
**CAUTION: Protective eyewear is needed for the procedure. (L011)**



**DANGER:** Heavy equipment—personal injury or equipment damage might result if mishandled. (L013)



**CAUTION:** Chemical resistant gloves are needed for this procedure. (L014)



**DANGER:** Risk of electric shock due to water or a water solution which is present in this product. Avoid working on or near energized equipment with wet hands or when spilled water is present. (L016)

## 5.2 Background:

This document contains the procedure for performing an air pressure test on a Bulk Power Enclosure (BPE) on an **IBM Power 775** system, using an **IBM Power 775** Fill and Drain Tool (FDT). This procedure is to be used on a BPE that has its components installed and connected to the BPE.

The successful execution of a **FDT Pressure Test Calibration** procedure is required for this procedure to be performed.

**NOTE:** *If performing a pressure test on a BPE that isn't populated with the BPE components refer to Appendix I for the non populated BPE pressure test procedure.*

To ensure that all **IBM Power 775** water-cooled BPE's are leak-free, the **IBM Power 775** Fill and Drain Tool (FDT) is equipped with pressure testing capability. The BPE pressure test is designed to identify leaks in the BPE internal plumbing along with the BPE components and must be completed before a BPE fill procedure is executed so that any potential for water leakage in the system can be avoided.

The results of the BPE pressure test are recorded within the FDT; if the test passes, a BPE fill procedure can be completed. If this test fails, there is a functional defect in the BPE or one of the populated components and the BPE fill cannot be completed. Upon a pressure test failure of a BPE, the next level of support must be contacted to replace the hardware.

A BPE fill procedure should not be executed unless both the **FDT Pressure Test Calibration** and **BPE Pressure Test** have passed since FDT activation.

The pressure test must be completed on an empty BPE. A new BPE should ship without water to the customer location, and no additional drainage is required. If the FDT senses that the BPE is not empty when the pressure test begins, the pressure test will stop. The pressure test status will be set as incomplete, and a BPE drain operation will be required.

### **Reference Information:**

<b>IBM Power 775</b> FDT P/N:	<b>45D6928</b>
Hose assemblies/adapters required:	<b>HA1</b> (45D8561) <b>HA2</b> (45D8562)

Expected maximum time to complete BPE pressure test: 4 min

**NOTE:** *Some steps in this procedure may be redundant due to other service operations being completed prior to this procedure. If a step has already been completed, verify that the step has been completed properly and proceed to the next step.*

**NOTE:** *The location of the component for the pressure test procedure is not important. The pressure test can be completed with the component on a cart, on the lift tool, or mechanically installed in the frame.*

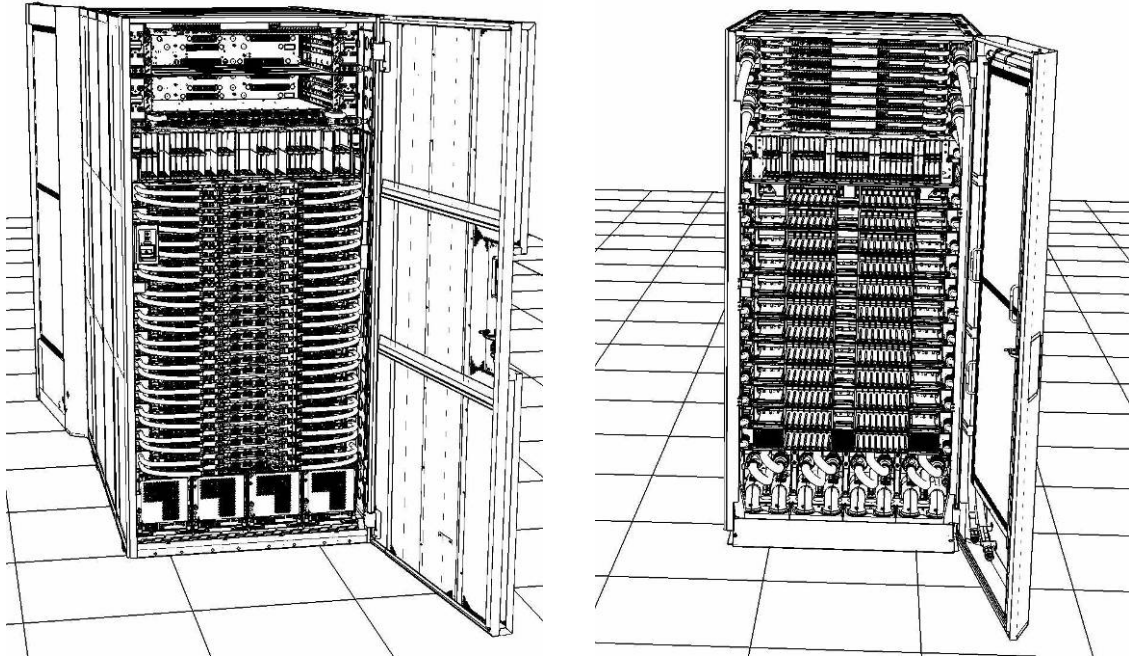
### **5.3 Procedure:**

**NOTE:** If you already have the FDT powered on, proceed to **Step 14**. Otherwise, start procedure at **Step 1**.

1. Identify the **Power 775** frame that requires service.

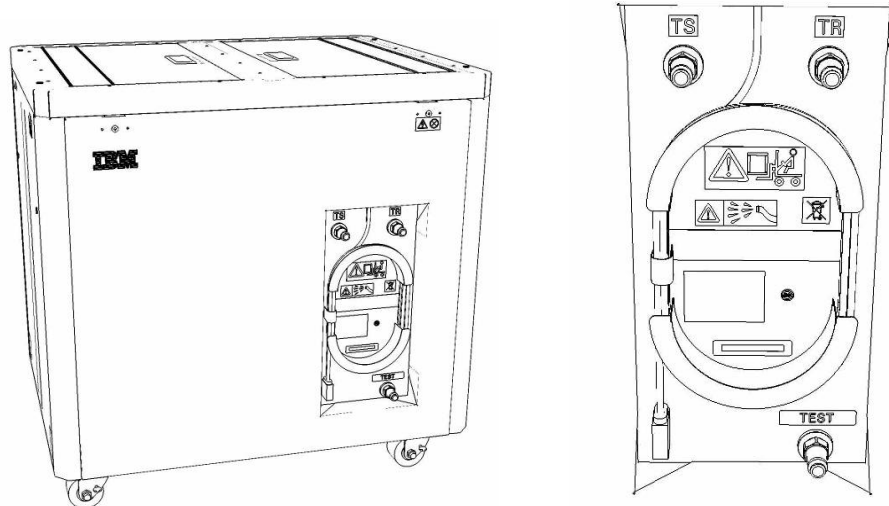
Verify that the system UEPO is set to **ON**, and the managing consoles (HMC and XCat) are powered on and communicating with the frame.

2. Open front and rear doors of the **Power 775** frame that requires service.

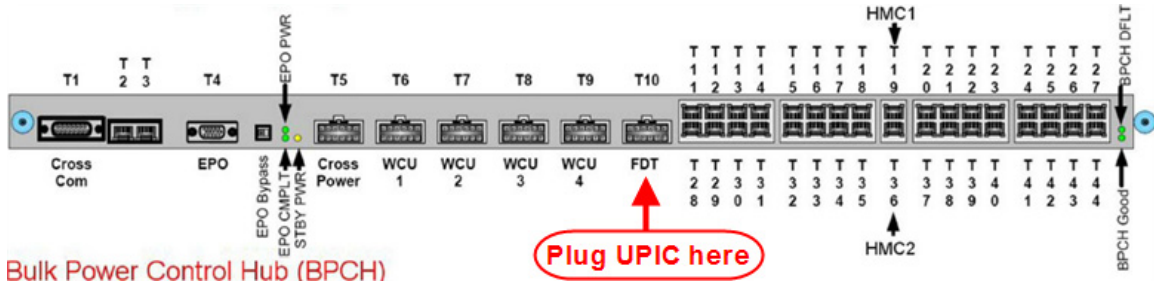


3. Bring the FDT to the front side of the **Power 775** frame that requires service.
4. Locate the panel of the FDT that contains the Universal Power and Information Cable (UPIC), as well as the **TS**, **TR**, and **TEST** water connections.

This side of the tool should be facing the front of the frame.

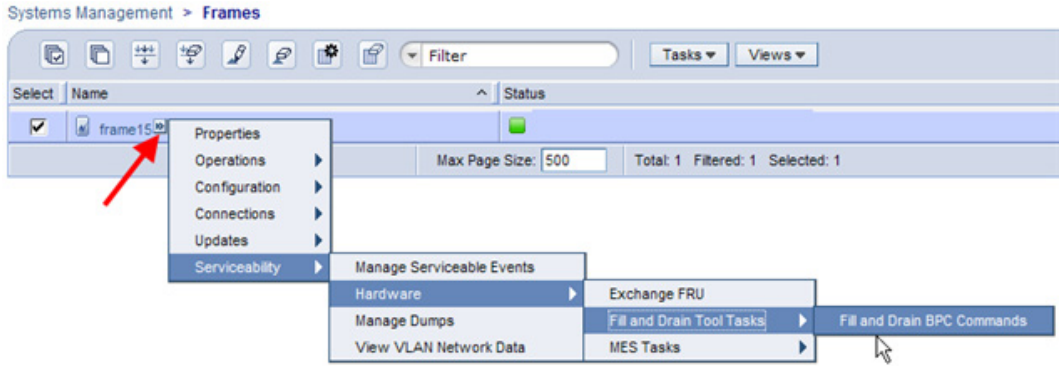


5. Unwrap the FDT UPIC cable from the storage loop on the FDT.
6. Select BPC port for FDT
  - If the lower BPA is not targeted for service, and is functional:  
Plug the FDT UPIC cable into **port T10 of the lower BPC.**
  - If the lower BPA is targeted for service, or is not functional:  
Plug the FDT UPIC cable into **port T10 of the upper BPC.**



7. Login to the HMC with the User ID `hscroot`.  
Use the HMC that is connected to the BPA where the FDT is plugged.
8. From the HMC left Navigation menu, expand **Systems Management** then select **Frames**.  
Verify frame serial number for the frame to be serviced.
9. In the **Frames** view on the HMC, place a checkmark in the **Select** column for the frame to be serviced.
10. Verify that the frame **Status** is **Rack Standby/Rack Standby** or **Standby/Standby**.
  - If frame **Status** reads **Standby/Rack Standby** or **Standby/Standby** – OK.  
Continue to next step.
  - If frame **Status** does not read **Rack Standby/Rack Standby** or **Standby/Standby** – action required. Contact next level of support.
11. From the **Task** menu on the HMC, *select* **Serviceability > Hardware > Fill and Drain Tool Tasks > Fill and Drain Command Interface**

Power775 Bulk Power Enclosure (BPE) Service Procedure  
 ---- Appendix B: BPE Pressure Test Procedure ----



**Fill and Drain Tool Command Interface** will display. See below for a sample image of the interface (FDT deactivated).

**Fill and Drain Tool (FDT) Command Interface - Server-78AC-100BC50029**

The table below shows the FDT Port locations that can communicate with the Fill and Drain Tool. Select the port to which the Fill and Drain Tool is connected. Use the buttons to drive commands to the Fill and Drain Tool connected to a port.

FDT Port Locations:

Select	Location Code	Description
<input type="radio"/>	78AC-100*BC50029-P7-C1	Lower BPC Port T10
<input type="radio"/>	78AC-100*BC50029-P8-C1	Upper BPC Port T10



12. Select the BPC port that the FDT was plugged into in **Step 6** from the **FDT Port Locations:** list.

13. *Click* the **Activate FDT** button.

- If the Activate FDT command is successful – OK. **Wait 30 seconds and continue to next step.**
- If the **Activate FDT** command fails – action required.

*Click* the **Deactivate FDT** button.

Wait 2 minutes and repeat **Step 13**. If the **Activate** command fails again, contact next level of support.

14. *Click* the **Get FDT Status** button.

- If the **Get FDT Status** command is successful – OK.

See below for a sample status (does not reflect expected state)

- If the **Get FDT Status** command fails – action required.

Repeat **Step 14**. If the **Get FDT Status** command fails again, contact next level of support.

**Fill and Drain Tool (FDT) Command Interface - Server-78AC-100BC50029**

The table below shows the FDT Port locations that can communicate with the Fill and Drain Tool. Select the port to which the Fill and Drain Tool is connected. Use the buttons to drive commands to the Fill and Drain Tool connected to a port.

FDT Port Locations:

Select	Location Code	Description
<input checked="" type="radio"/>	78AC-100*BC50029-P7-C1	Lower BPC Port T10
<input type="radio"/>	78AC-100*BC50029-P8-C1	Upper BPC Port T10

FDT Power/Comm: GOOD  
 Frame Attached: IBM Power7 775  
 MDA-FD RL: 45D  
 Error Status: WARNING  
 Tank Level: Full  
 Air Pump: Off  
 Water Pump: DISABLED  
 Tool Mode: Ready  
 Pressure Test Calibration: Incomplete  
 Component Pressure Test: Incomplete

Sample FDT Status

15. Review the FDT status screen and ensure that the following status items are OK:

Status Item	State	Action
• <b>Tool Mode:</b>	<b>Ready</b>	– OK. Check next Status item.
• <b>Error Status:</b>	<b>NONE</b>	– OK. Check next Status item.
	<b>WARNING</b>	– <i>click</i> the <b>Decode Error Status</b> button, record the information returned and check Tank Level.
	<b>CRITICAL</b>	– <i>click</i> the <b>Decode Error Status</b> button, record the information returned and contact next level of support.
• <b>Tank Level:</b>	<b>Upper Half, Lower Half or Empty</b>	– OK. Check next Status item.

**Full** – action required.

Exit this procedure and complete a **Fill and Drain Tool (FDT) Tank Drain Procedure**.

Once FDT tank level is **Upper Half, Lower Half** or **Empty**, return to this step and continue with procedure.

- **Pressure Test Calibration:** **Pass** - OK. Check next Status item.  
**Incomplete** or **Fail** – action required.  
Exit this procedure and complete the **Pressure Test Calibration** procedure.  
Once a **passing** result is confirmed, return to this step and continue with procedure.
- **Component Pressure Test:** **Incomplete** – OK. Continue to next step.  
**Pass** or **Fail** – action required.  
*Click* the **Reset FDT** button and proceed to next step.

16. Verify all BPE components are connected to the BPE being tested.

17. Verify that BPE water connections **are not** connected to system manifolds.

BPE should be drained of water.

18. Before proceeding, read required safety information:

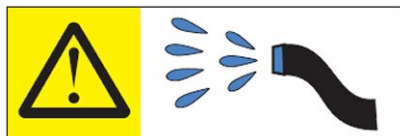
**CAUTION:** The water-based coolant solution may contain an additive intended to inhibit corrosion (or provide other functions). The solution may cause irritation to the skin or eyes. Avoid direct contact with the solution. Employ appropriate Personal Protective Equipment when performing operations involving the coolant or which may potentially expose you to the coolant. Refer to the MSDS for more information. (C037)



**CAUTION:** Protective eyewear is needed for the procedure. (L011)



**CAUTION:** Chemical resistant gloves are needed for this procedure. (L014)



**DANGER:** Risk of electric shock due to water or a water solution which is present in this product. Avoid working on or near energized equipment with wet hands or when spilled water is present. (L016)

19. Verify BPE position for pressure test.

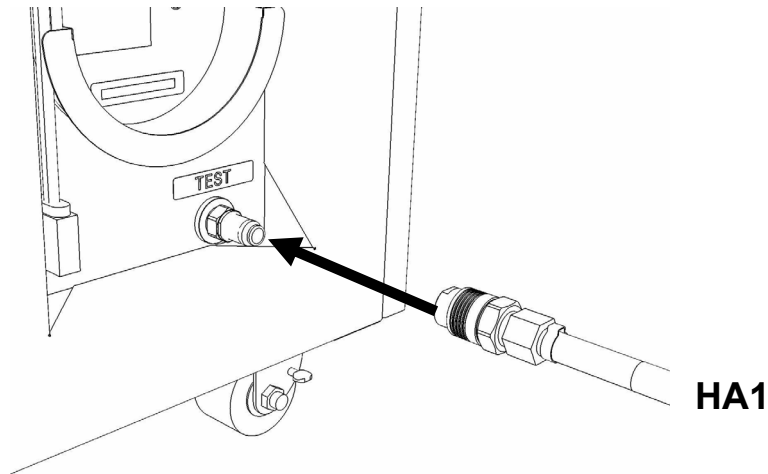
- If the BPE is not installed in the system – continue to next step.
- If the BPE is installed in the system – action required.

Pass the unattached ends of **HA1** and **HA2** to the rear of the frame.

**NOTE:** Hose assemblies **HA1** and **HA2** can be passed **around** the frame or **over** the frame, depending on frame position. These hoses are long enough to complete all FDT service actions on the rear of the frame.

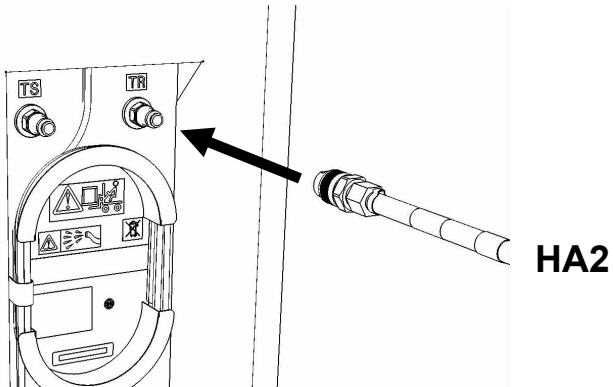
20. Remove hose assembly **HA1** from the upper tool storage compartment.

Connect either end of hose assembly **HA1** to the **TEST** connection on the front panel of the FDT.

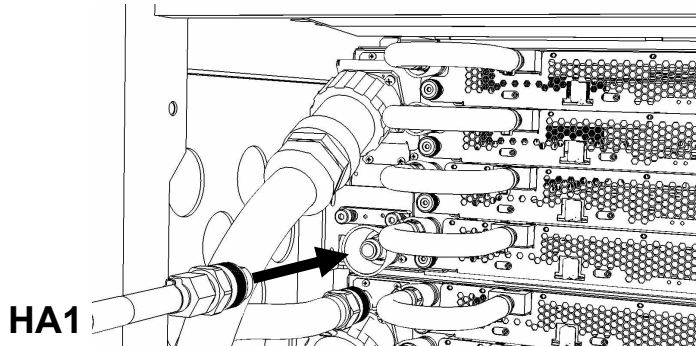


21. Remove hose assembly **HA2** from the upper tool storage compartment.

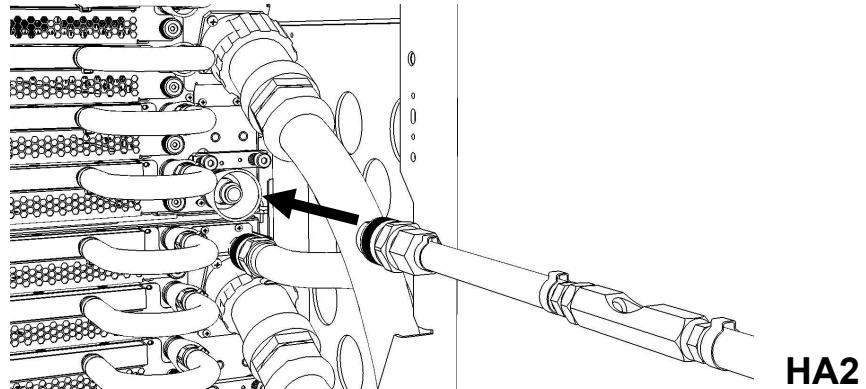
Connect the end *without sight glass* to the **TR** connection on the FDT.



22. Connect the unattached end of hose assembly **HA1** to the left side BPE water connection.

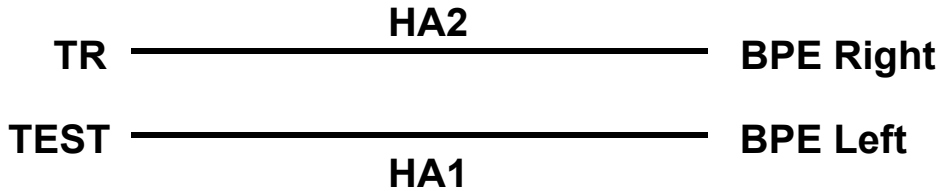


23. Connect the unattached end *with sight glass* of hose assembly **HA2** the right side BPE water connection.



24. Ensure all hose connections are made properly and securely.

Verify hoses are connected as outlined in the schematic below.



25. On the FDT Panel, *click* the **Component Pressure Test** button.

The **Get FDT Status** button may be *clicked* to examine FDT status.

**NOTE:** *The pressure testing will last for 4 minutes (2 minutes with air pump on)*

**CAUTION:** **This unit must not be left running unattended, service personnel should always be overseeing the process. (C038)**

26. Click Get Status and ensure that the following status items are OK:

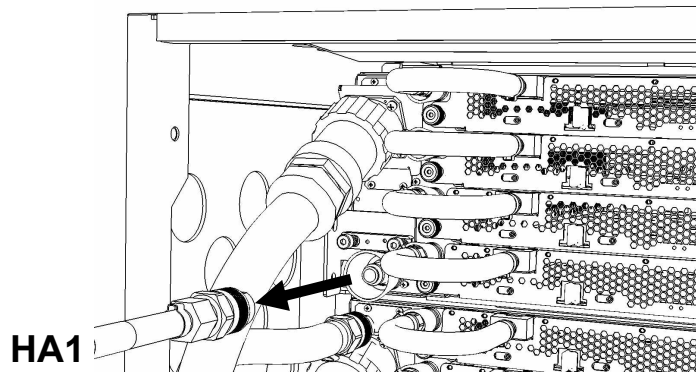
Status Item	State	Action
<ul style="list-style-type: none"> <li><b>Tool mode:</b></li> </ul>	<p><b>Ready</b> – OK. Check next Status item.</p> <p><b>System/Component Pressure Test Mode</b> – pressure test still running.</p> <p>Wait 30 seconds and repeat <b>Step 26</b>.</p>	
<ul style="list-style-type: none"> <li><b>Error Status:</b></li> </ul>	<p><b>NONE</b> – OK. Check next Status item.</p> <p><b>WARNING</b> – <i>click</i> the <b>Decode Error Status</b> button, record information returned and proceed to next step.</p> <p><b>CRITICAL</b> – <i>click</i> the <b>Decode Error Status</b> button, record information returned and contact next level of support.</p>	
<ul style="list-style-type: none"> <li><b>Component Pressure Test:</b></li> </ul>	<p><b>Pass</b> – OK. Proceed to next step.</p> <p><b>Fail or Incomplete</b> – action required.</p> <p><i>Click</i> the <b>Reset FDT</b> button.</p> <p>Repeat <b>Step 20</b> through <b>Step 24</b> and continue with procedure.</p> <p>If the test reads <b>Fail</b> twice, hardware is defective. Contact next level of support.</p>	

27. The component pressure test has passed successfully.

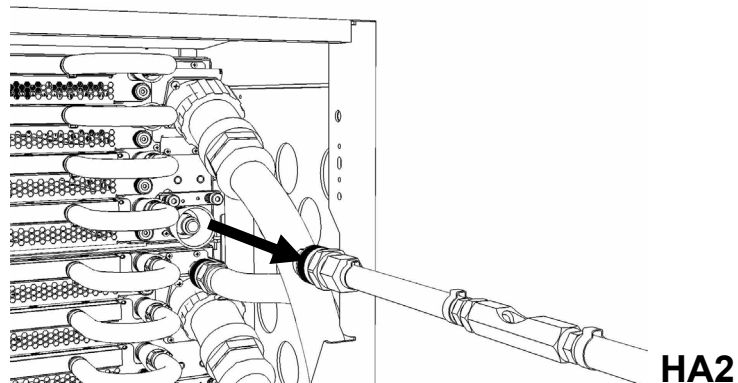
If required, a BPE fill procedure can now be completed.

**NOTE:** *If a BPE Fill Procedure will be completed following this test, disregard Step 28, 29, 31 and 32. These hose connections will be the same in the BPE fill procedure.*

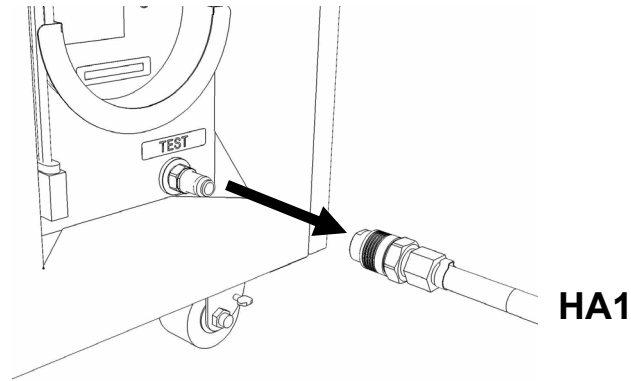
28. Disconnect the **HA1** hose assembly from the left side BPE water connection.



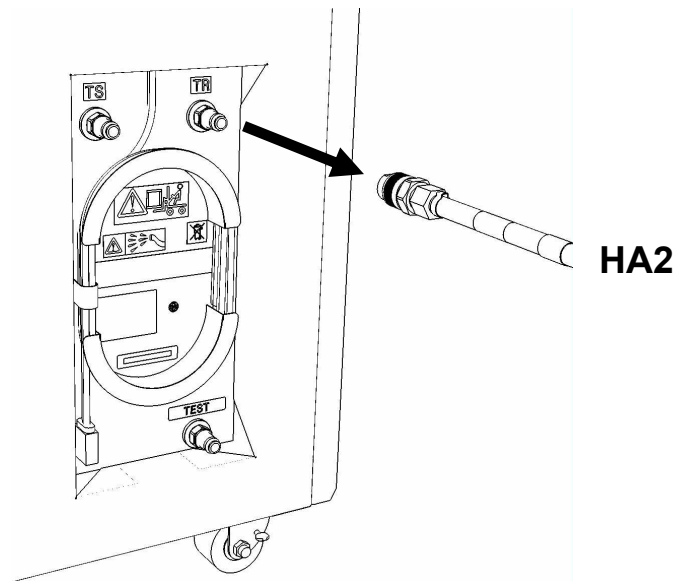
29. Disconnect the **HA2** hose assembly from the right side BPE water connection.



30. Disconnect the FDT end of **HA1** from **TEST** on the FDT.



31. Disconnect the FDT end of **HA2** from **TR** on the FDT.



32. Place all hose assemblies and adapters in their appropriate locations within the FDT storage enclosure.

33. Determine whether the FDT will be used for another procedure:

- If the FDT will be used for another procedure, leave tool activated and go to that procedure now; skip the remaining steps of this procedure.
- If the FDT requires no further use - proceed to the next step.

34. Click the **Deactivate FDT** button.

- If the **Deactivate FDT** command is successful – OK. Proceed to next step.
- If the **Deactivate FDT** command fails– action required.

Repeat **Deactivate FDT**. If the **Deactivate FDT** command fails again, contact next level of support.



35. Disconnect FDT UPIC power cable from port T10 of BPC used.

Wrap the UPIC cable in appropriate cable storage location on FDT.

36. If this procedure was referenced from another procedure, return to parent procedure.

---

**5.4 End of Appendix B: Power775 Bulk Power Enclosure  
(BPE) Pressure Test Procedure with Components**

---

---

## 6 APPENDIX C: POWER775 BULK POWER ENCLOSURE (BPE) FILL PROCEDURE

---

### 6.1 Safety Notices

Read “Safety Notices“ available from InfoCenter:

<http://publib.boulder.ibm.com/infocenter/powersys/v3r1m5/topic/p7hdx/G229-9054.pdf>

The following cautions apply to all Power775 service procedures:

**CAUTION:**

**Energy hazard present. Shorting might result in system outage and possible physical injury. Remove all metallic jewelry before servicing. (C001)**

**CAUTION:**

**The doors and covers to the product are to be closed at all times except for service by trained service personnel. All covers must be replaced and doors locked at the conclusion of the service operation. (C013)**

**CAUTION:**

**Servicing of this product or unit is to be performed by trained service personnel only. (C032)**

The following notices specifically pertain to this Power775 service procedure.

**CAUTION: The water-based coolant solution may contain an additive intended to inhibit corrosion (or provide other functions). The solution may cause irritation to the skin or eyes. Avoid direct contact with the solution. Employ appropriate Personal Protective Equipment when performing operations involving the coolant or which may potentially expose you to the coolant. Refer to the MSDS for more information. (C037)**

**CAUTION: This unit must not be left running unattended, service personnel should always be overseeing the process. (C038)**



**DANGER: Hazardous voltage present. Voltages present constitute a shock hazard, which can cause severe injury or death. (L004)**



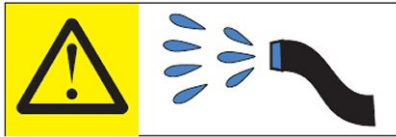
**CAUTION: Protective eyewear is needed for the procedure. (L011)**



**DANGER:** Heavy equipment—personal injury or equipment damage might result if mishandled.  
(L013)



**CAUTION:** Chemical resistant gloves are needed for this procedure. (L014)



**DANGER:** Risk of electric shock due to water or a water solution which is present in this product. Avoid working on or near energized equipment with wet hands or when spilled water is present.  
(L016)

## 6.2 Background:

This document contains the procedure for filling a Bulk Power Enclosure (BPE) on an **IBM Power 775** system with conditioned water using an **IBM Power 775** Fill and Drain Tool (FDT). The successful execution of a **BPE Pressure Test** procedure is required for this procedure to be performed.

Due to high packaging density and heat load, the **IBM Power 775** BPE is water cooled, and contains internal plumbing to route cooling water towards and carry heat away from critical power sub-components.

In the event that a new BPE is to be added to a **IBM Power 775** system, the BPE must be tested for leaks and then filled with treated system water prior to installation into the frame. All water cooled field replaceable units (FRU's), including BPE's, are shipped empty to the client location from IBM to eliminate the risk of damage from water leakage.

Do not connect an empty BPE to the system as this would cause a large volume of air to be distributed throughout the system, resulting in increased component temperatures. Filling a BPE with the FDT prior to system connection prevents these conditions, and purges the air from the BPE through the use of a circulating water pump.

To ensure that the BPE plumbing is leak free prior to installation, the BPE must pass a BPE pressure test before the BPE can be filled. A BPE fill operation should not be performed unless the BPE pressure test has a passing result with a calibrated FDT.

### **Reference Information:**

<b>IBM Power 775</b> FDT P/N:	<b>45D6928</b>
Hose assemblies/adapters required:	<b>HA1</b> (45D8561) <b>HA2</b> (45D8562)

Approximate BPE water volume: 0.5 L  
Expected time to fully fill BPE with FDT: 30 s

**NOTE:** *Some steps in this procedure may be redundant due to other service operations being completed prior to this procedure. If a step has already been completed, verify that the step has been completed properly and proceed to the next step.*

**NOTE:** *The location of the component for the fill procedure is not important. The fill procedure can be completed with the component on a cart, on the lift tool, or mechanically installed in the frame.*

---

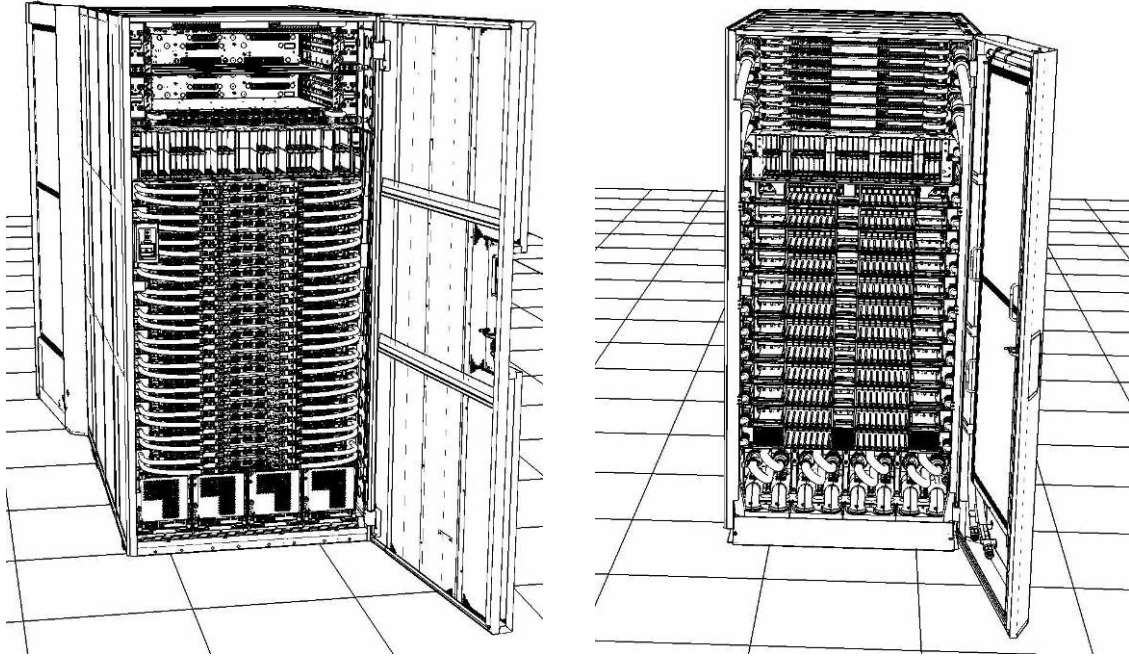
## 6.3 Procedure:

**NOTE:** If you already have the FDT powered on, proceed to **Step 14**. Otherwise, start procedure at **Step 1**.

1. Identify the **Power 775** frame that requires service.

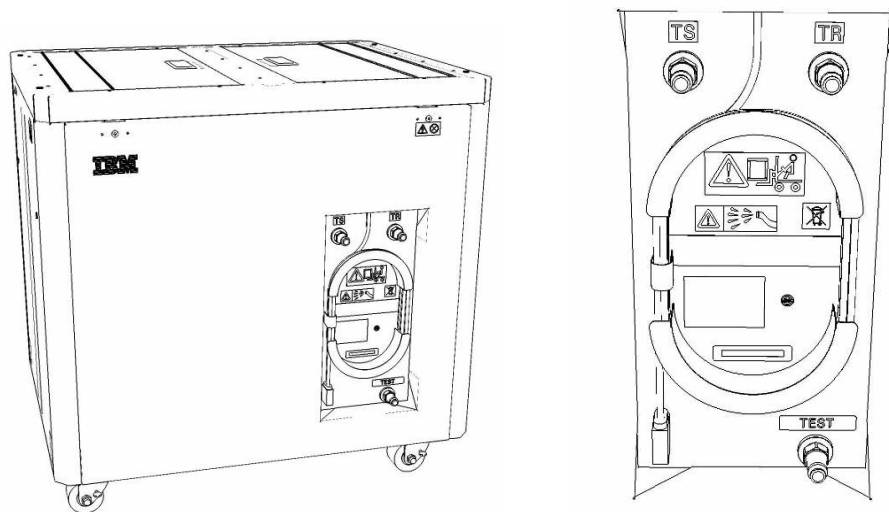
Verify that the system UEPO is set to **ON**, and the managing consoles (HMC and XCat) are powered on and communicating with the frame.

2. Open front and rear doors of the **Power 775** frame that requires service.



3. Bring the FDT to the front side of the **Power 775** frame that requires service.
4. Locate the panel of the FDT that contains the Universal Power and Information Cable (UPIC), as well as the **TS**, **TR**, and **TEST** water connections.

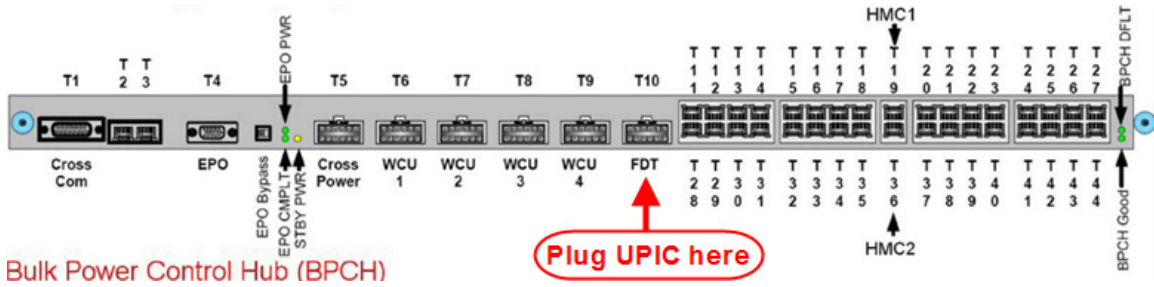
This side of the tool should be facing the front of the frame.



5. Unwrap the FDT UPIC cable from the storage loop on the FDT.

6. Select BPC port for FDT

- If the lower BPA is not targeted for service, and is functional:  
 Plug the FDT UPIC cable into **port T10 of the lower BPC**.
- If the lower BPA is targeted for service, or is not functional:  
 Plug the FDT UPIC cable into **port T10 of the upper BPC**.



7. Login to the HMC with the User ID `hscroot`.

Use the HMC that is connected to the BPA where the FDT is plugged.

8. From the HMC left Navigation menu, expand **Systems Management** then select **Frames**.

Verify frame serial number for the frame to be serviced.

9. In the **Frames** view on the HMC, place a checkmark in the **Select** column for the frame to be serviced.

10. Verify that the frame **Status** is **Rack Standby/Rack Standby** or **Standby/Standby**.

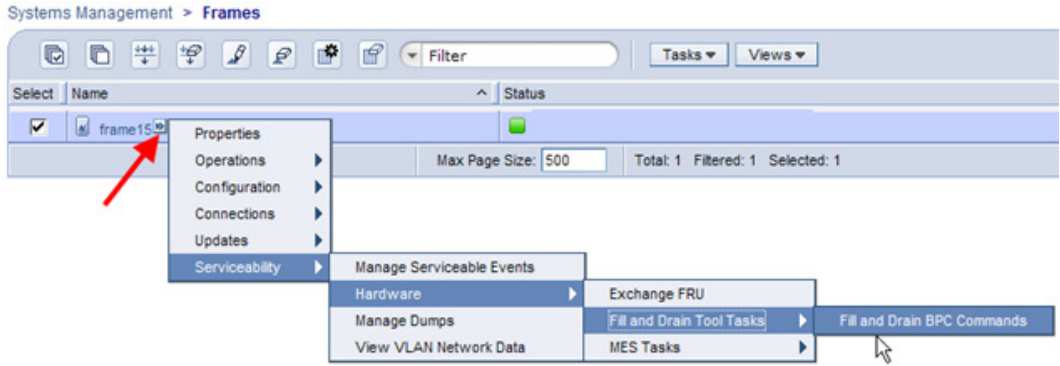
- If frame **Status** reads **Rack Standby/Rack Standby** or **Standby/Standby** – OK.

Continue to next step.

- If frame **Status** does not read **Rack Standby/Rack Standby** or **Standby/Standby** – action required. Contact next level of support.

11. From the **Task** menu on the HMC, *select* **Serviceability** > **Hardware** > **Fill and Drain Tool Tasks** > **Fill and Drain Command Interface**

Power775 Bulk Power Enclosure (BPE) Service Procedure  
 ---- Appendix C: BPE Fill Procedure ----



**Fill and Drain Tool Command Interface** will display. See below for a sample image of the interface (FDT deactivated).

**Fill and Drain Tool (FDT) Command Interface - Server-78AC-100BC50029**

The table below shows the FDT Port locations that can communicate with the Fill and Drain Tool. Select the port to which the Fill and Drain Tool is connected. Use the buttons to drive commands to the Fill and Drain Tool connected to a port.

FDT Port Locations:

Select	Location Code	Description
<input type="radio"/>	78AC-100*BC50029-P7-C1	Lower BPC Port T10
<input type="radio"/>	78AC-100*BC50029-P8-C1	Upper BPC Port T10

12. Select the BPC port that the FDT was plugged into in **Step 6** from the **FDT Port Locations:** list.

13. *Click* the **Activate FDT** button.

- If the Activate FDT command is successful – OK. **Wait 30 seconds and continue to next step.**
- If the **Activate FDT** command fails – action required.

*Click* the **Deactivate FDT** button.

Wait 2 minutes and repeat **Step 13**. If the **Activate** command fails again, contact next level of support.

14. *Click* the **Get FDT Status** button.

- If the **Get FDT Status** command is successful – OK.

See below for a sample status (does not reflect expected state)

- If the **Get FDT Status** command fails – action required.

Repeat **Step 14**. If the **Get FDT Status** command fails again, contact next level of support.



**Fill and Drain Tool (FDT) Command Interface - Server-78AC-100BC50029**

The table below shows the FDT Port locations that can communicate with the Fill and Drain Tool. Select the port to which the Fill and Drain Tool is connected. Use the buttons to drive commands to the Fill and Drain Tool connected to a port.

FDT Port Locations:

Select	Location Code	Description
<input checked="" type="radio"/>	78AC-100*BC50029-P7-C1	Lower BPC Port T10
<input type="radio"/>	78AC-100*BC50029-P8-C1	Upper BPC Port T10

FDT Power/Comm: GOOD  
 Frame Attached: IBM Power7 775  
 MDA-FD RL: 45D  
 Error Status: WARNING  
 Tank Level: Full  
 Air Pump: Off  
 Water Pump: DISABLED  
 Tool Mode: Ready  
 Pressure Test Calibration: Incomplete  
 Component Pressure Test: Incomplete

Sample FDT Status

15. Review the FDT status screen and ensure that the following status items are OK:

Status Item	State	Action
-------------	-------	--------

- **Tool Mode:** **Ready** – OK. Check next Status item.
- **Error Status:** **NONE** – OK. Check next Status item.  
**WARNING** – *click* the **Decode Error Status** button, record the information returned and check Tank Level.  
**CRITICAL** – *click* the **Decode Error Status** button, record the information returned and contact next level of support.
- **Tank Level:** **Full** or **Upper Half** – OK. Check next Status item.

**Lower Half or Empty** – action required.

Exit this procedure and perform a **Fill and Drain Tool (FDT) Tank Fill Procedure**.

Once FDT tank level is **Full** or **Upper Half**, return to this step and continue with procedure.

- **Component Pressure Test: Pass** – OK. Proceed to next step.

This procedure **should not** be continued if the component pressure test did not **Pass**.

**Incomplete or Fail** – action required.

Exit this procedure and complete a **BPE Pressure Test Procedure**.

Once a **passing** result is confirmed, return to this step and continue with procedure.

16. Verify all BPR and BPD water hoses are connected to the BPE being serviced.

BPR's and BPD must be installed in BPE during fill procedure.

**NOTE:** All BPR's and the BPD within this BPE will be filled during this procedure.

17. Verify BPE water connections **are not** connected to system manifolds.

18. Before proceeding, read required safety information:

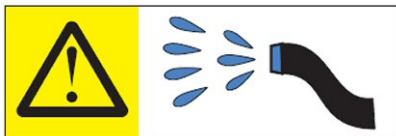
**CAUTION:** The water-based coolant solution may contain an additive intended to inhibit corrosion (or provide other functions). The solution may cause irritation to the skin or eyes. Avoid direct contact with the solution. Employ appropriate Personal Protective Equipment when performing operations involving the coolant or which may potentially expose you to the coolant. Refer to the MSDS for more information. (C037)



**CAUTION:** Protective eyewear is needed for the procedure. (L011)



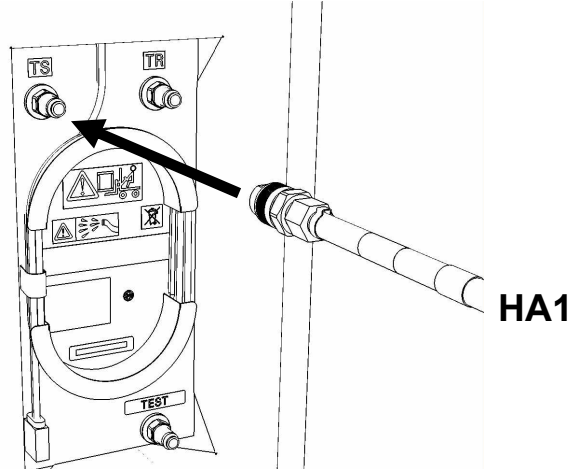
**CAUTION:** Chemical resistant gloves are needed for this procedure. (L014)



**DANGER:** Risk of electric shock due to water or a water solution which is present in this product. Avoid working on or near energized equipment with wet hands or when spilled water is present. (L016)

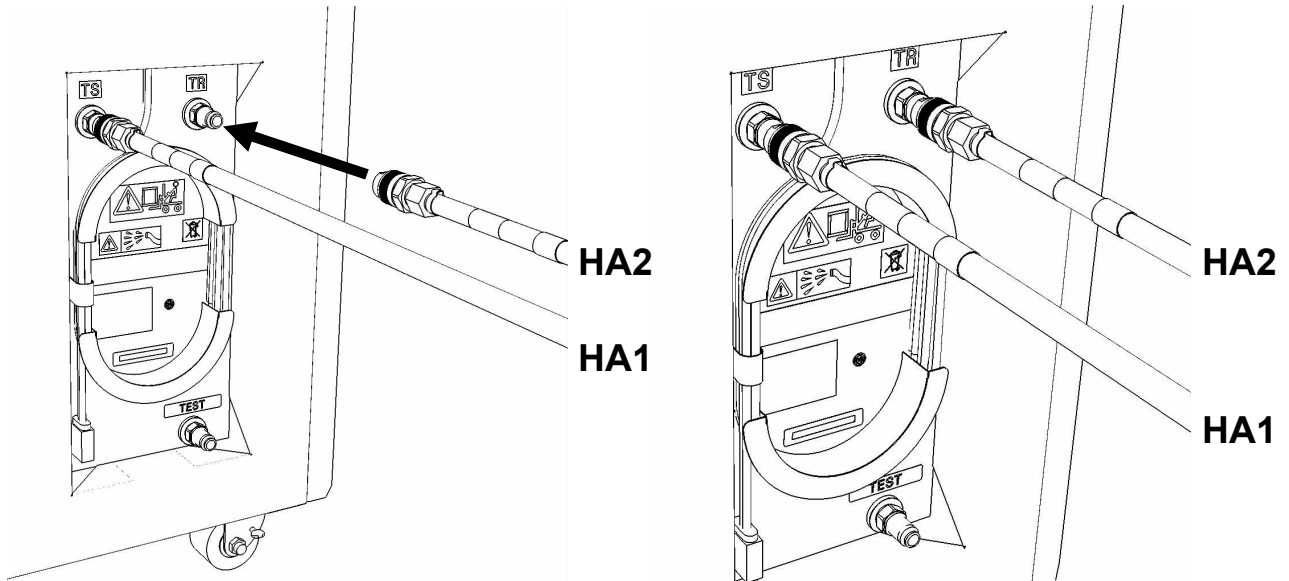
19. Remove hose assembly **HA1** from the upper tool storage compartment.

Connect either end of hose assembly **HA1** to the **TS** connection on the front panel of the FDT.



20. Remove hose assembly **HA2** from the upper tool storage compartment.

Connect the end *without sight glass* to the **TR** connection on the FDT.



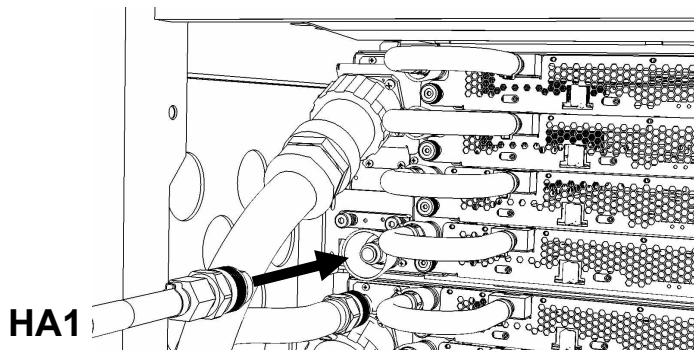
21. Verify BPE position for fill procedure.

- If the BPE is not installed in the system – continue to next step.
- If the BPE is installed in the system – action required.

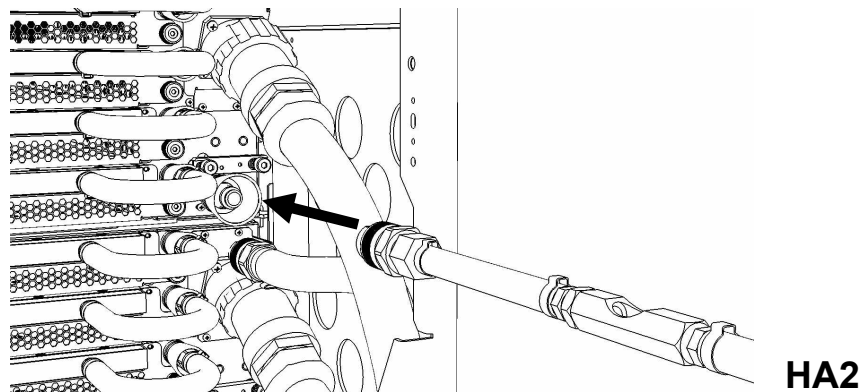
Pass the unattached ends of **HA1** and **HA2** to the rear of the frame.

**NOTE:** Hose assemblies **HA1** and **HA2** can be passed **around** the frame or **over** the frame, depending on frame position. These hoses are long enough to complete all FDT service actions on the rear of the frame.

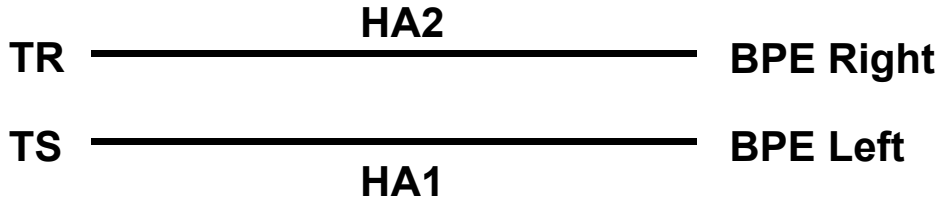
22. Connect the unattached end of hose assembly **HA1** to the left side BPE water connection.



23. Connect the unattached end *with sight glass* of hose assembly **HA2** the right side BPE water connection.



24. Ensure all hose connections are made properly and securely.  
Verify hoses are connected as outlined in the schematic below.



25. On the FDT panel, *click* the **Start Water Pump** button.

The **Get FDT Status** button may be *clicked* to examine FDT status.

**NOTE:** *The water pump will shut off after 30 minutes of run time.*

**Approximate time to fill a BPE:** 60 seconds.

**CAUTION:** **This unit must not be left running unattended, service personnel should always be overseeing the process. (C038)**

26. Inspect the sight glass in hose assembly **HA2** while the water pump is running.

The sight glass will indicate the filling status of this step.

**Expected sight glass behavior**

- Sight glass will start out full of air while the component is being purged of air.
- After some period of time, water will start passing through the sight glass in an air/water mixture.
- Eventually the sight glass will become full of water, with intermittent small air bubbles.

**Full sight glass definition**

- The sight glass is considered full of water **when** water flow is obvious (white ball pinned in direction of FDT) **and** no large bubbles of air are observed.
- If the above description is observed and the water appears cloudy, this is also considered full.

27. If the water pump has stopped unexpectedly without *clicking* the **Reset FDT** button:

Click Get Status and ensure that the following status items are OK:

<u>Status Item</u>	<u>State</u>	<u>Action</u>
• <b>Tool mode:</b>	<b>Ready</b> – OK. Check next Status item. <b>Tool mode: System/Component Fill Mode</b> – water pump still running. Proceed to <b>Step 28</b> .	
• <b>Tank Level:</b>	<b>Full, Upper Half, or Lower Half</b> – OK. Check next Status item. <b>Empty</b> – action required. FDT tank fill required. Exit this procedure and complete a <b>Fill and Drain Tool (FDT) Tank Fill Procedure</b> . Once FDT tank level is <b>Full</b> or <b>Upper Half</b> return to <b>Step 19</b> and continue with procedure.	
• <b>Error Status:</b>	<b>NONE</b> – OK. Proceed to next step. <b>WARNING</b> – <i>click</i> the <b>Decode Error Status</b> button, record information returned and proceed to next step. <b>CRITICAL</b> – <i>click</i> the <b>Decode Error Status</b> button, record information returned and contact next level of support.	

28. If the sight glass in **HA2** never becomes full of water:

Ensure all hose connections in **Step 1** through **Step 24** are made properly.

Complete the diagnostics in **Step 27**.

- If the sight glass in **HA2** becomes full of water, continue with procedure.
- If the sight glass in **HA2** does not become full of water, contact next level of support.

29. When the sight glass in **HA2** has been mostly solid water for 60 seconds:

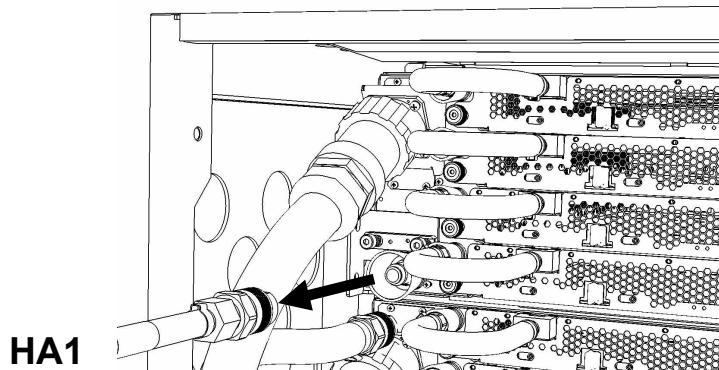
*Click* the **Reset FDT** button.

30. Click the Get FDT Status button and ensure the following status items are OK:

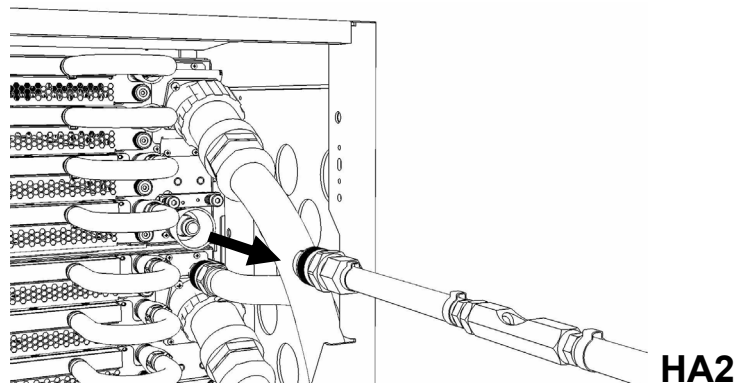
Status Item	State	Action
• <b>Tool mode:</b>	<b>Ready</b> – OK. Check next Status item.	
	<b>System/Component Fill Mode</b> – water pump still running. Repeat <b>Step 29</b> .	
• <b>Error Status:</b>	<b>NONE</b> – OK. Proceed to next step.	
	<b>WARNING</b> – <i>click</i> the <b>Decode Error Status</b> button, record information returned and proceed to next step.	
	<b>CRITICAL</b> – <i>click</i> the <b>Decode Error Status</b> button, record information returned and contact next level of support.	

31. The BPE fill procedure has completed successfully. The BPE can be connected to the system manifolds.

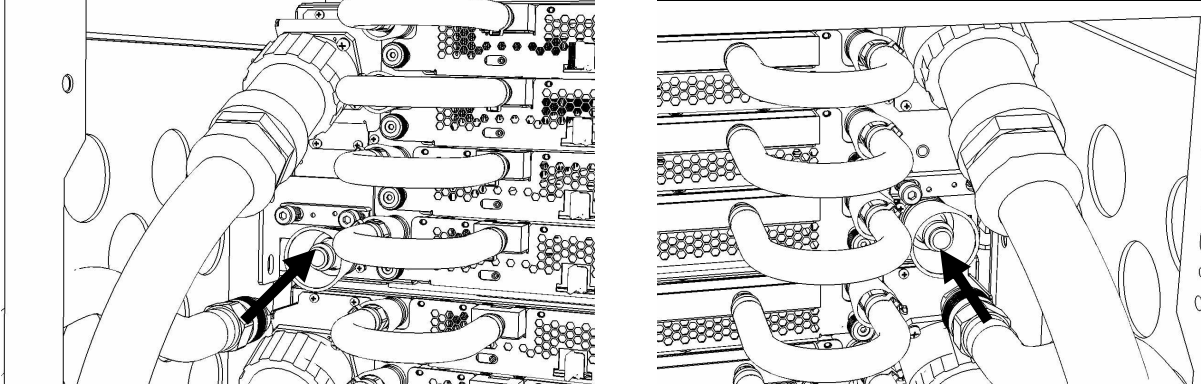
32. Disconnect the **HA1** hose assembly from the left side BPE water connection.



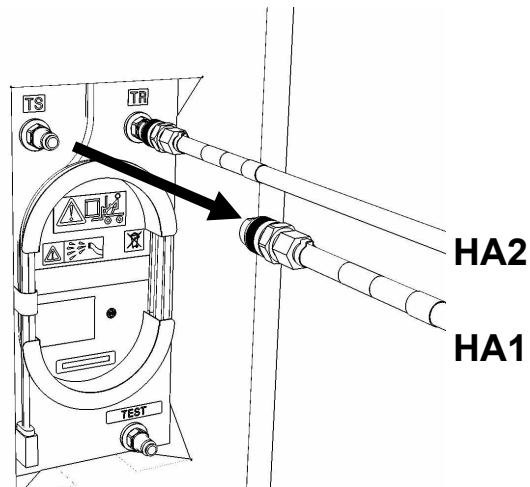
33. Disconnect the **HA2** hose assembly from the right side BPE water connection.



34. Connect the system manifold hoses to the BPE water connections.

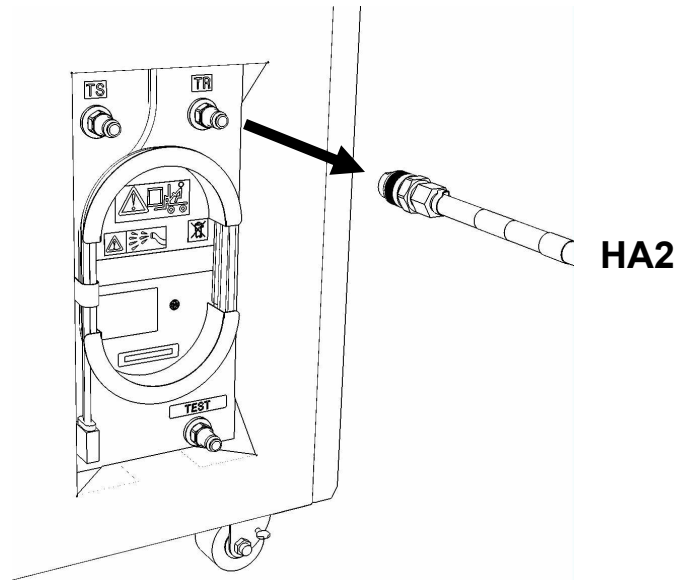


35. Disconnect the FDT end of **HA1** from **TS** on the FDT.



36. Disconnect the FDT end of **HA2** from **TR** on the FDT.





37. Place all hose assemblies and adapters in their appropriate locations within the FDT storage enclosure.

38. Determine whether the FDT will be used for another procedure:

- If the FDT will be used for another procedure, leave tool activated and go to that procedure now; skip the remaining steps of this procedure.
- If the FDT requires no further use - proceed to the next step.

39. Click the **Deactivate FDT** button.

- If the **Deactivate FDT** command is successful – OK. Proceed to next step.
- If the **Deactivate FDT** command fails– action required.

Repeat **Deactivate FDT**. If the **Deactivate FDT** command fails again, contact next level of support.

40. Disconnect FDT UPIC power cable from port T10 of BPC used.

Wrap the UPIC cable in appropriate cable storage location on FDT.

41. If this procedure was referenced from another procedure, return to parent procedure.

---

## 6.4 End of Appendix C: Power775 Bulk Power Enclosure (BPE) Fill Procedure

---

## 7 APPENDIX D: POWER775 BULK POWER ENCLOSURE (BPE) DRAIN PROCEDURE

---

### 7.1 Safety Notices

Read “Safety Notices“ available from InfoCenter:

<http://publib.boulder.ibm.com/infocenter/powersys/v3r1m5/topic/p7hdx/G229-9054.pdf>

The following cautions apply to all Power775 service procedures:

**CAUTION:**

**Energy hazard present. Shorting might result in system outage and possible physical injury. Remove all metallic jewelry before servicing. (C001)**

**CAUTION:**

**The doors and covers to the product are to be closed at all times except for service by trained service personnel. All covers must be replaced and doors locked at the conclusion of the service operation. (C013)**

**CAUTION:**

**Servicing of this product or unit is to be performed by trained service personnel only. (C032)**

The following notices specifically pertain to this Power775 service procedure.

**CAUTION: The water-based coolant solution may contain an additive intended to inhibit corrosion (or provide other functions). The solution may cause irritation to the skin or eyes. Avoid direct contact with the solution. Employ appropriate Personal Protective Equipment when performing operations involving the coolant or which may potentially expose you to the coolant. Refer to the MSDS for more information. (C037)**

**CAUTION: This unit must not be left running unattended, service personnel should always be overseeing the process. (C038)**



**DANGER: Hazardous voltage present. Voltages present constitute a shock hazard, which can cause severe injury or death. (L004)**



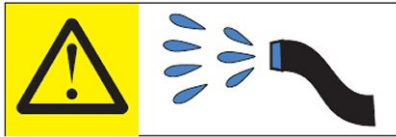
**CAUTION: Protective eyewear is needed for the procedure. (L011)**



**DANGER:** Heavy equipment—personal injury or equipment damage might result if mishandled.  
(L013)



**CAUTION:** Chemical resistant gloves are needed for this procedure. (L014)



**DANGER:** Risk of electric shock due to water or a water solution which is present in this product.  
Avoid working on or near energized equipment with wet hands or when spilled water is present.  
(L016)

## 7.2 Background:

This document contains the procedure for draining the water out of a Bulk Power Enclosure (BPE) on an **IBM Power 775** system using an **IBM Power 775** Fill and Drain Tool (FDT).

Due to high packaging density and heat load, the **IBM Power 775** BPE is water cooled, and contains internal plumbing to route cooling water towards and carry heat away from critical power sub-components.

In the event that a BPE is scheduled for removal from a **IBM Power 775** system, the BPE will need to be drained of water prior to removal. All water cooled field replaceable units (FRU's), including BPE's, must be shipped empty from the client location to IBM to eliminate the risk of damage from water leakage. Draining components with the **IBM Power 775** Fill and Drain Tool (FDT) eliminates the risk of water leaks due to low temperatures or shock and vibration, which could result in permanently damaged cooling and electronic components on the BPE. Draining a BPE with the FDT purges the water from the component with pressurized air, and returns the water to the internal reservoir within the FDT for reuse.

After a BPE drain procedure has been completed, the BPE water plumbing may be under a slight positive pressure due to the pressurized air that was flowing through the component. This is expected, and the pressure will be no greater than 5 psi.

### **Reference Information:**

<b>IBM Power 775</b> FDT P/N:	<b>45D6928</b>
Hose assemblies/adapters required:	<b>HA1</b> (45D8561) <b>HA2</b> (45D8562)

Approximate BPE water volume: 1.0 L  
Expected time to fully drain BPE with FDT: 20 s

---

**NOTE:** Some steps in this procedure may be redundant due to other service operations being completed prior to this procedure. If a step has already been completed, verify that the step has been completed properly and proceed to the next step.

**NOTE:** The location of the component for the drain procedure is not important. The drain procedure can be completed with the component on a cart, on the lift tool, or mechanically installed in the frame.

---

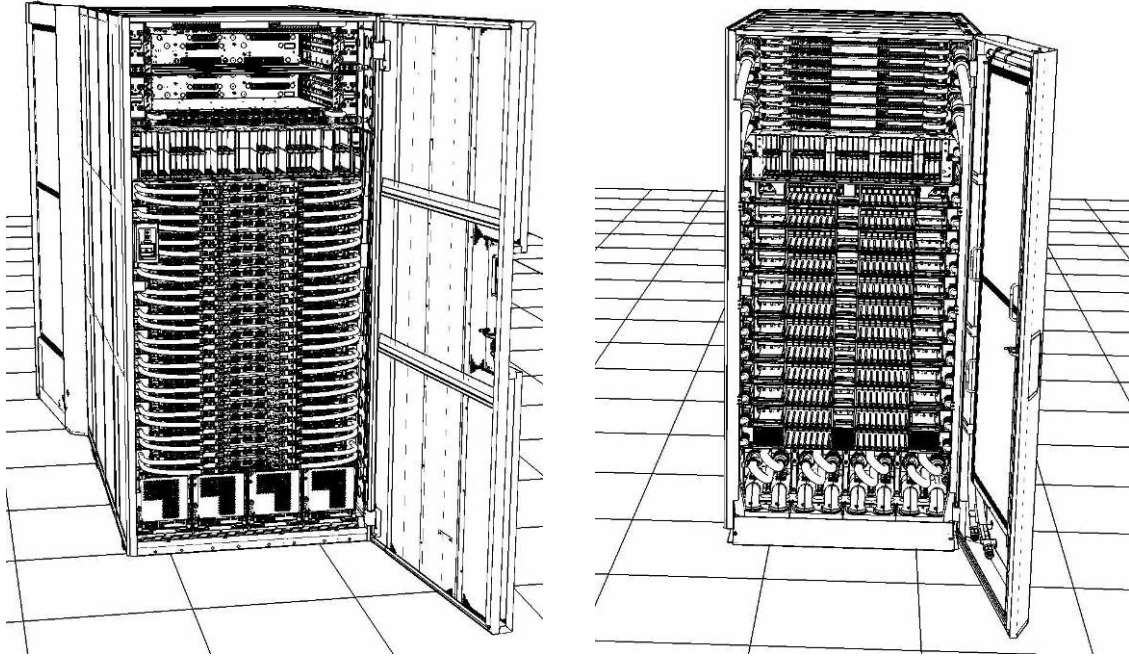
## 7.3 Procedure:

**NOTE:** If you already have the FDT powered on, proceed to **Step 14**. Otherwise, start procedure at **Step 1**.

1. Identify the **Power 775** frame that requires service.

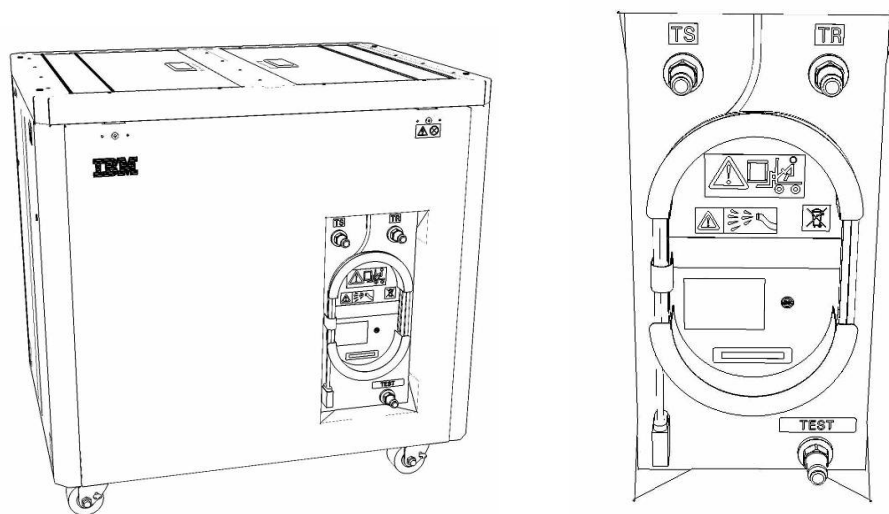
Verify that the system UEPO is set to **ON**, and the managing consoles (HMC and XCat) are powered on and communicating with the frame.

2. Open front and rear doors of the **Power 775** frame that requires service.



3. Bring the FDT to the front side of the **Power 775** frame that requires service.
4. Locate the panel of the FDT that contains the Universal Power and Information Cable (UPIC), as well as the **TS**, **TR**, and **TEST** water connections.

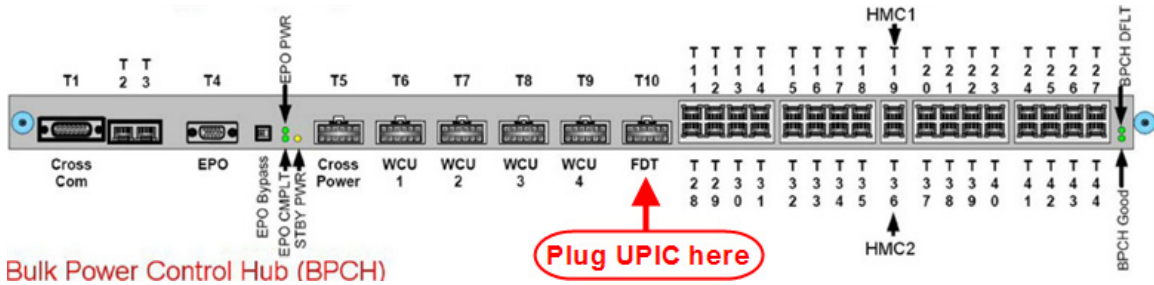
This side of the tool should be facing the front of the frame.



5. Unwrap the FDT UPIC cable from the storage loop on the FDT.

6. Select BPC port for FDT

- If the lower BPA is not targeted for service, and is functional:  
Plug the FDT UPIC cable into **port T10 of the lower BPC**.
- If the lower BPA is targeted for service, or is not functional:  
Plug the FDT UPIC cable into **port T10 of the upper BPC**.



7. Login to the HMC with the User ID `hscroot`.

Use the HMC that is connected to the BPA where the FDT is plugged.

8. From the HMC left Navigation menu, expand **Systems Management** then select **Frames**.

Verify frame serial number for the frame to be serviced.

9. In the **Frames** view on the HMC, place a checkmark in the **Select** column for the frame to be serviced.

10. Verify that the frame **Status** is **Rack Standby/Rack Standby** or **Standby/Standby**.

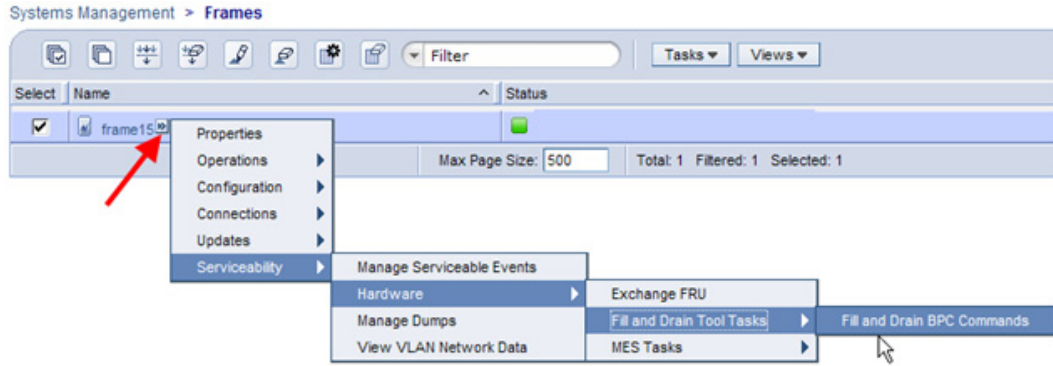
- If frame **Status** reads **Rack Standby/Rack Standby** or **Standby/Standby** – OK.

Continue to next step.

- If frame **Status** does not read **Rack Standby/Rack Standby** or **Standby/Standby** – action required. Contact next level of support.

11. From the **Task** menu on the HMC, *select* **Serviceability** > **Hardware** > **Fill and Drain Tool Tasks** > **Fill and Drain Command Interface**

Power775 Bulk Power Enclosure (BPE) Service Procedure  
 ---- Appendix E: FDT Pressure Calibration Procedure ----



**Fill and Drain Tool Command Interface** will display. See below for a sample image of the interface (FDT deactivated).

**Fill and Drain Tool (FDT) Command Interface - Server-78AC-100BC50029**

The table below shows the FDT Port locations that can communicate with the Fill and Drain Tool. Select the port to which the Fill and Drain Tool is connected. Use the buttons to drive commands to the Fill and Drain Tool connected to a port.

FDT Port Locations:

Select	Location Code	Description
<input type="radio"/>	78AC-100*BC50029-P7-C1	Lower BPC Port T10
<input type="radio"/>	78AC-100*BC50029-P8-C1	Upper BPC Port T10

12. Select the BPC port that the FDT was plugged into in **Step 6** from the **FDT Port Locations:** list.

13. *Click* the **Activate FDT** button.

- If the Activate FDT command is successful – OK. **Wait 30 seconds and continue to next step.**
- If the **Activate FDT** command fails – action required.

*Click* the **Deactivate FDT** button.

Wait 2 minutes and repeat **Step 13**. If the **Activate** command fails again, contact next level of support.

14. *Click* the **Get FDT Status** button.

- If the **Get FDT Status** command is successful – OK.

See below for a sample status (does not reflect expected state)

- If the **Get FDT Status** command fails – action required.

Repeat **Step 14**. If the **Get FDT Status** command fails again, contact next level of support.



**Fill and Drain Tool (FDT) Command Interface - Server-78AC-100BC50029**

The table below shows the FDT Port locations that can communicate with the Fill and Drain Tool. Select the port to which the Fill and Drain Tool is connected. Use the buttons to drive commands to the Fill and Drain Tool connected to a port.

FDT Port Locations:

Select	Location Code	Description
<input checked="" type="radio"/>	78AC-100*BC50029-P7-C1	Lower BPC Port T10
<input type="radio"/>	78AC-100*BC50029-P8-C1	Upper BPC Port T10

FDT Power/Comm: GOOD  
 Frame Attached: IBM Power7 775  
 MDA-FD RL: 45D  
 Error Status: WARNING  
 Tank Level: Full  
 Air Pump: Off  
 Water Pump: DISABLED  
 Tool Mode: Ready  
 Pressure Test Calibration: Incomplete  
 Component Pressure Test: Incomplete

Sample FDT Status

15. Review the FDT status screen and ensure that the following status items are OK:

Status Item	State	Action
-------------	-------	--------

- **Tool Mode:** **Ready** – OK. Check next Status item.
- **Error Status:** **NONE** – OK. Check next Status item.

**WARNING** – *click* the **Decode Error Status** button, record the information returned and check Tank Level.

**CRITICAL** – *click* the **Decode Error Status** button, record the information returned and contact next level of support.

- **Tank Level:** **Lower Half** or **Empty**– OK. Check next Status item.  
**Full** or **Upper Half** – action required.

Exit this procedure and complete a **Fill and Drain Tool (FDT) Tank Drain Procedure**.

Once FDT tank level is **Lower Half** or **Empty**, return to this step and continue with procedure.

16. Verify all BPR and BPD water hoses are connected to the BPE being serviced.

BPR's and BPD must be installed in BPE during drain procedure.

**NOTE:** All BPR's and BPD in this BPE will be drained during this procedure. They will be refilled during the BPE fill procedure.

17. Verify that the BPE being serviced is powered-off:

**BPE GOOD** LED should be off.

BPE should have been powered-off during mechanical removal procedure.

18. Before proceeding, read required safety information:

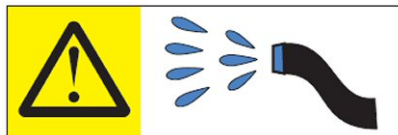
**CAUTION:** The water-based coolant solution may contain an additive intended to inhibit corrosion (or provide other functions). The solution may cause irritation to the skin or eyes. Avoid direct contact with the solution. Employ appropriate Personal Protective Equipment when performing operations involving the coolant or which may potentially expose you to the coolant. Refer to the MSDS for more information. (C037)



**CAUTION:** Protective eyewear is needed for the procedure. (L011)



**CAUTION:** Chemical resistant gloves are needed for this procedure. (L014)



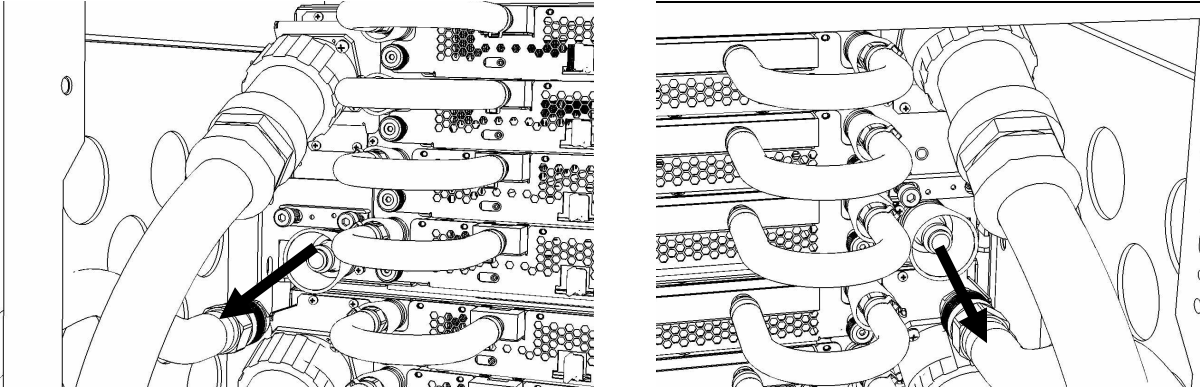
**DANGER:** Risk of electric shock due to water or a water solution which is present in this product. Avoid working on or near energized equipment with wet hands or when spilled water is present. (L016)

19. Verify BPE position for drain procedure.

- If the BPE is not installed in the system – continue to next step.
- If the BPE is installed in the system – action required.

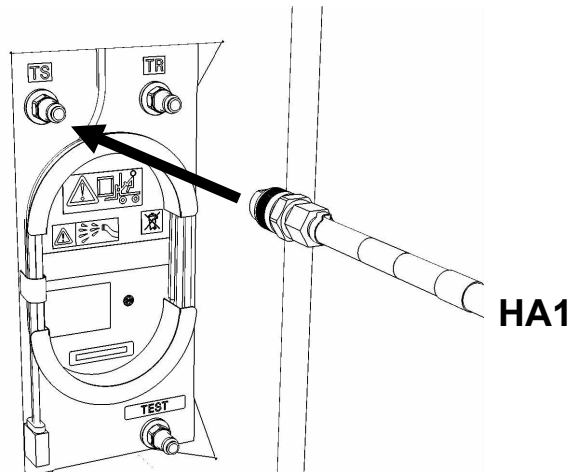
Disconnect the left **and** right main water connections from the BPE to be drained.

**NOTE:** Do not disconnect water connections on a BPE that has not been powered off. Loss of water flow will result in BPE overheating and failure.



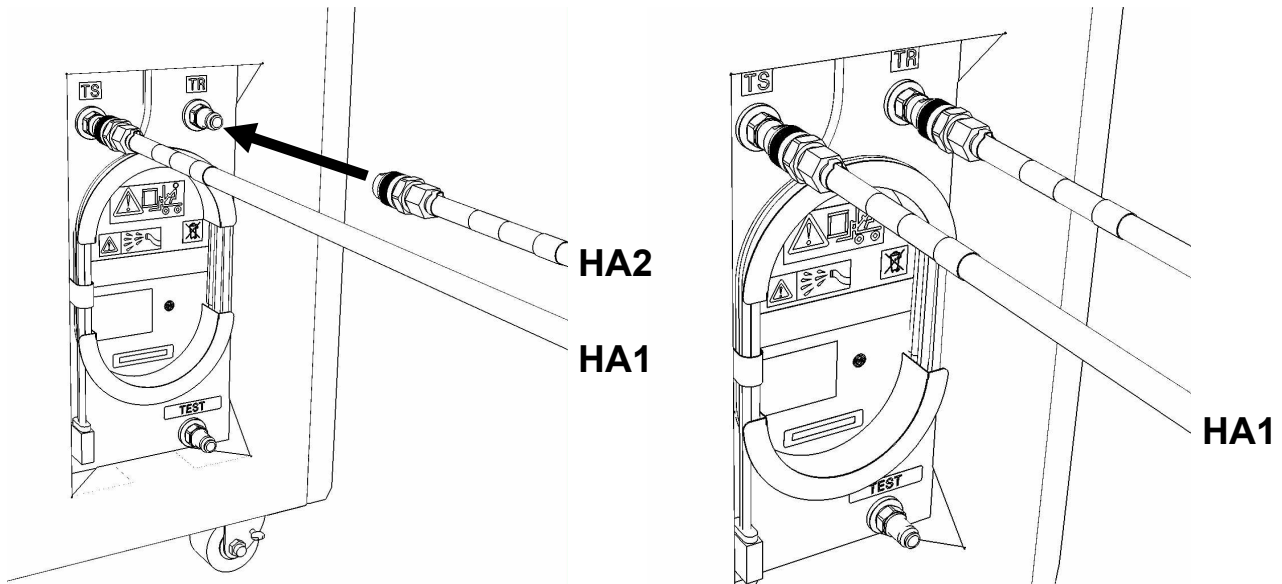
20. Remove hose assembly **HA1** from the upper tool storage compartment.

Connect either end of hose assembly **HA1** to the **TS** connection on the front panel of the FDT.



21. Remove hose assembly **HA2** from the upper tool storage compartment.

Connect the end *without sight glass* to the **TR** connection on the FDT.



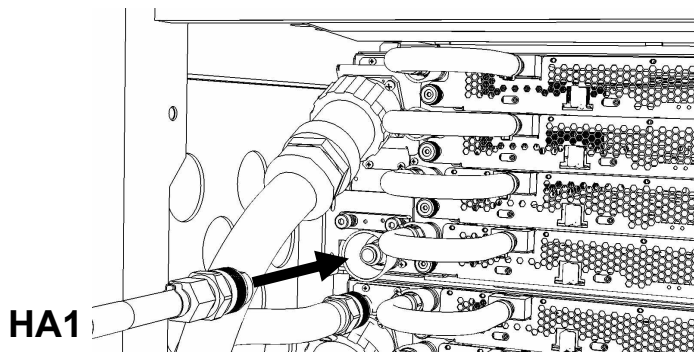
22. Verify BPE position for drain procedure.

- If the BPE is not installed in the system – continue to next step.
- If the BPE is installed in the system – action required.

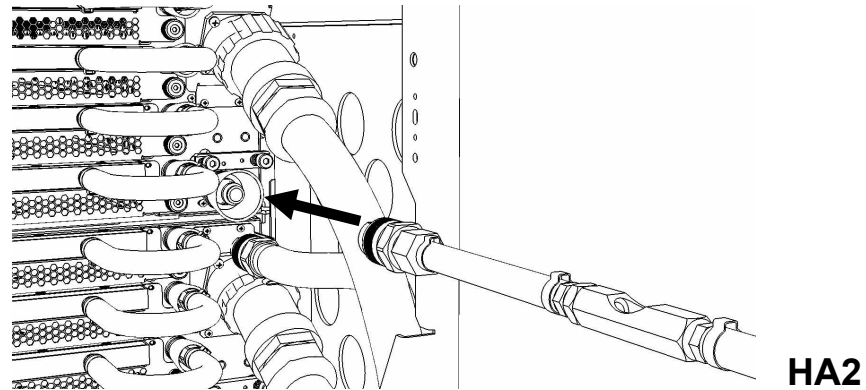
Pass the unattached ends of **HA1** and **HA2** to the rear of the frame.

**NOTE:** Hose assemblies **HA1** and **HA2** can be passed **around** the frame or **over** the frame, depending on frame position. These hoses are long enough to complete all FDT service actions on the rear of the frame.

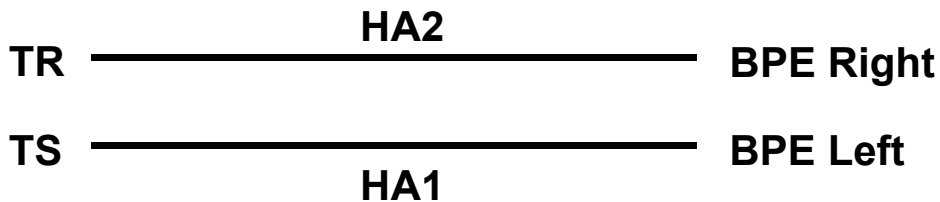
23. Connect the unattached end of hose assembly **HA1** to the left side BPE water connection.



24. Connect the unattached end *with sight glass* of hose assembly **HA2** the right side BPE water connection.



25. Ensure all hose connections are made properly and securely.  
Verify hoses are connected as outlined in the schematic below.



26. On the FDT panel, *click* the **Start Air Pump** button.

The **Get FDT Status** button may be *clicked* to examine FDT status.

**NOTE:** The air pump will shut off after 1 minute, 40 seconds of run time.

**CAUTION:** This unit must not be left running unattended, service personnel should always be overseeing the process. (C038)

27. Inspect the sight glass in hose assembly **HA2**.

The sight glass will provide verification that the component has been drained.

**Expected sight glass behavior**

- Sight glass will start out full of water while the component is being emptied.
- After some period of time, air will start passing through the sight glass in an air/water mixture.
- Eventually the sight glass will become full of air, with small water droplets/mist passing through the sight glass.

28. When the air pump has stopped running, review the following:

- **HA2** sight glass filled with air when pump stopped – OK.  
Component empty. Proceed to next step.
- **HA2** sight glass filled with water when air pump stopped – action required.  
Repeat **Step 20** through **Step 27**.

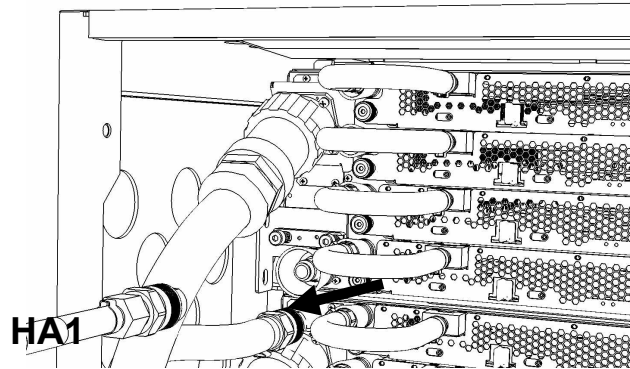
29. Click Get Status and ensure that the following status items are OK:

Status Item	State	Action
• <b>Tool mode:</b>	<b>Ready</b> – OK. Check next Status item. <b>System/Component Drain Mode</b> – air pump still running. Wait 30 seconds and repeat <b>Step 29</b> .	
• <b>Error Status:</b>	<b>NONE</b> – OK. Check next Status item I. <b>WARNING</b> – <i>click</i> the <b>Decode Error Status</b> button, record information returned and proceed to next step. <b>CRITICAL</b> – <i>click</i> the <b>Decode Error Status</b> button, record information returned and contact next level of support.	
• <b>Tank Level:</b>	<b>Empty, Lower Half, Upper Half</b> – OK. Proceed to next step. <b>Full</b> – action required. FDT tank drain required. Exit this procedure and complete a <b>Fill and Drain Tool (FDT) Tank Drain Procedure</b> . Once FDT tank level is <b>Empty</b> or <b>Lower Half</b> , return to <b>Step 20</b> and continue with procedure.	

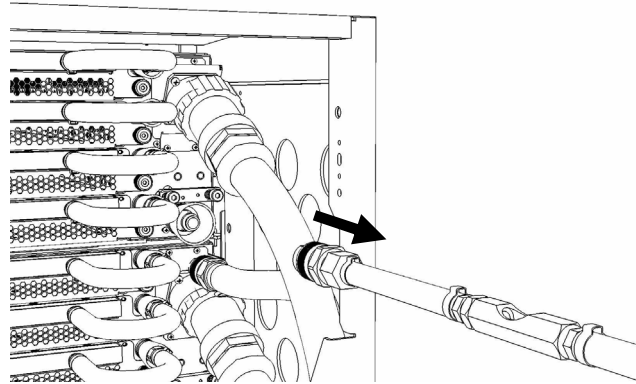
30. The BPE drain procedure has completed successfully, and the BPE has been emptied of water.

**NOTE:** *If a BPE Pressure Test Procedure will be completed following this test, disregard Step 31, 32 and 34. These hose connections will be the same in the BPE pressure test procedure.*

31. Disconnect the **HA1** hose assembly from the left side BPE water connection.

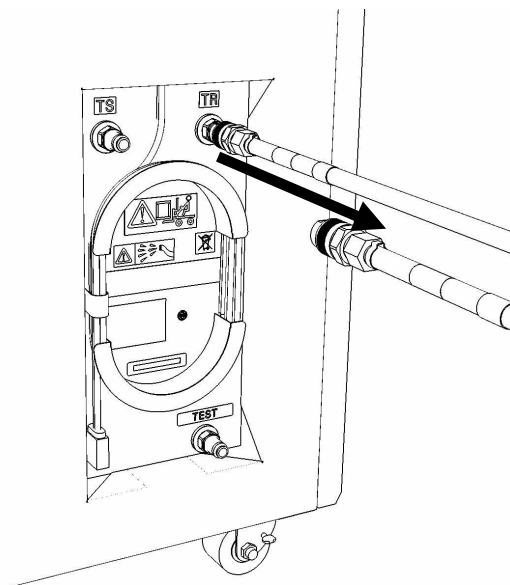


32. Disconnect the **HA2** hose assembly from the right side BPE water connection.



**HA2**

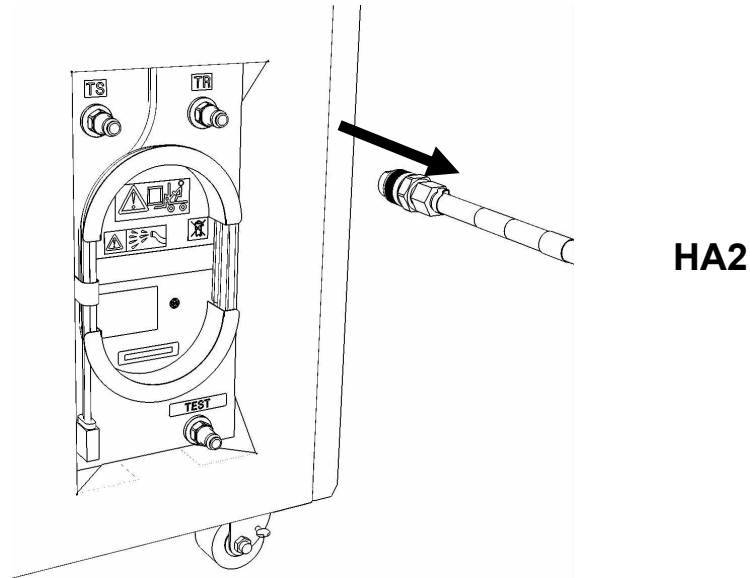
33. Disconnect the FDT end of **HA1** from **TS** on the FDT.



**HA2**

**HA1**

34. Disconnect the FDT end of **HA2** from **TR** on the FDT.



35. Place all hose assemblies and adapters in their appropriate locations within the FDT storage enclosure.

36. Determine whether the FDT will be used for another procedure:

- If the FDT will be used for another procedure, leave tool activated and go to that procedure now; skip the remaining steps of this procedure.
- If the FDT requires no further use - proceed to the next step.

37. *Click* the **Deactivate FDT** button.

- If the **Deactivate FDT** command is successful – OK. Proceed to next step.
- If the **Deactivate FDT** command fails– action required.

Repeat **Deactivate FDT**. If the **Deactivate FDT** command fails again, contact next level of support.

38. Disconnect FDT UPIC power cable from port T10 of BPC used.

39. Wrap the UPIC cable in appropriate cable storage location on FDT.

40. If this procedure was referenced from another procedure, return to parent procedure.

---

## 7.4 End of Appendix D: Power775 Bulk Power Enclosure (BPE) Drain Procedure



---

## 8 APPENDIX E: POWER775 FILL AND DRAIN TOOL (FDT) PRESSURE TEST CALIBRATION PROCEDURE

---

### 8.1 Safety Notices

Read “Safety Notices“ available from InfoCenter:

<http://publib.boulder.ibm.com/infocenter/powersys/v3r1m5/topic/p7hdx/G229-9054.pdf>

The following cautions apply to all Power775 service procedures:

**CAUTION:**

**Energy hazard present and Shorting might result in system outage and possible physical injury. Remove all metallic jewelry before servicing. (C001)**

**CAUTION:**

**The doors and covers to the product are to be closed at all times except for service by trained service personnel. All covers must be replaced and doors locked at the conclusion of the service operation. (C013)**

**CAUTION:**

**Service of this product or unit is to be performed by trained service personnel only. (C032)**

The following notices specifically pertain to this Power775 service procedure.

**CAUTION: The water-based coolant solution may contain an additive intended to inhibit corrosion (or provide other functions). The solution may cause irritation to the skin or eyes. Avoid direct contact with the solution. Employ appropriate Personal Protective Equipment when performing operations involving the coolant or which may potentially expose you to the coolant. Refer to the MSDS for more information. (C037)**

**CAUTION: This unit must not be left running unattended, service personnel should always be overseeing the process. (C038)**



**DANGER: Hazardous voltage present. Voltages present constitute a shock hazard, which can cause severe injury or death. (L004)**



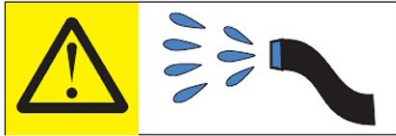
**CAUTION: Protective eyewear is needed for the procedure. (L011)**



**DANGER:** Heavy equipment—personal injury or equipment damage might result if mishandled. (L013)



**CAUTION:** Chemical resistant gloves are needed for this procedure. (L014)



**DANGER:** Risk of electric shock due to water or a water solution which is present in this product. Avoid working on or near energized equipment with wet hands or when spilled water is present. (L016)

## 8.2 Background:

This document contains the procedure for performing an **IBM Power 775** Fill and Drain Tool (FDT) pressure test calibration procedure for an **IBM Power 775** system.

To ensure that all water cooled components in the **IBM Power 775** system are leak-free, the **IBM Power 775** Fill and Drain Tool (FDT) is equipped with air pressure testing capability. The FDT Pressure Test Calibration routine is designed as a diagnostic test to verify the integrity of the FDT air pump, associated plumbing, and hose assemblies. This procedure tests for leaks within the FDT and FDT hose assemblies, and *must* be completed before a component (FRU) pressure test or fill is executed. The results of the calibration routine are recorded within the FDT.

**If the calibration passes**, system and component pressure tests can be completed.

**If the calibration fails**, there is a functional defect in the FDT or hose assemblies. System or component pressure tests cannot be completed. System or component fills must not be completed unless pressure tests are done first to ensure there are no leaks. Upon a calibration failure, the next level of support must be contacted for FDT debug and repair.

Once the FDT has been activated, a system or component fill procedure cannot be executed unless both the Pressure Test Calibration and Component Pressure Test have passed. The water pump within the FDT will otherwise be disabled until these conditions are met.

To properly complete a pressure test, the FDT hose assemblies must be purged of water. No specific hose drain procedure is required; the Pressure Test Calibration routine will drain all required hose assemblies if they have been left full of water.

### **Reference Information:**

<b>IBM Power 775</b> FDT P/N:	<b>45D6928</b>
Hose assemblies/adapters required:	<b>HA1</b> (45D8561) <b>HA2</b> (45D8562) <b>A3</b> (45D8567)

Total Pressure Test Calibration runtime: 1 min (air pump on 30 s)

**NOTE:** *Some steps in this procedure may be redundant due to other service operations being completed prior to this procedure. If a step has already been completed, verify that the step has been completed properly and proceed to the next step.*

---

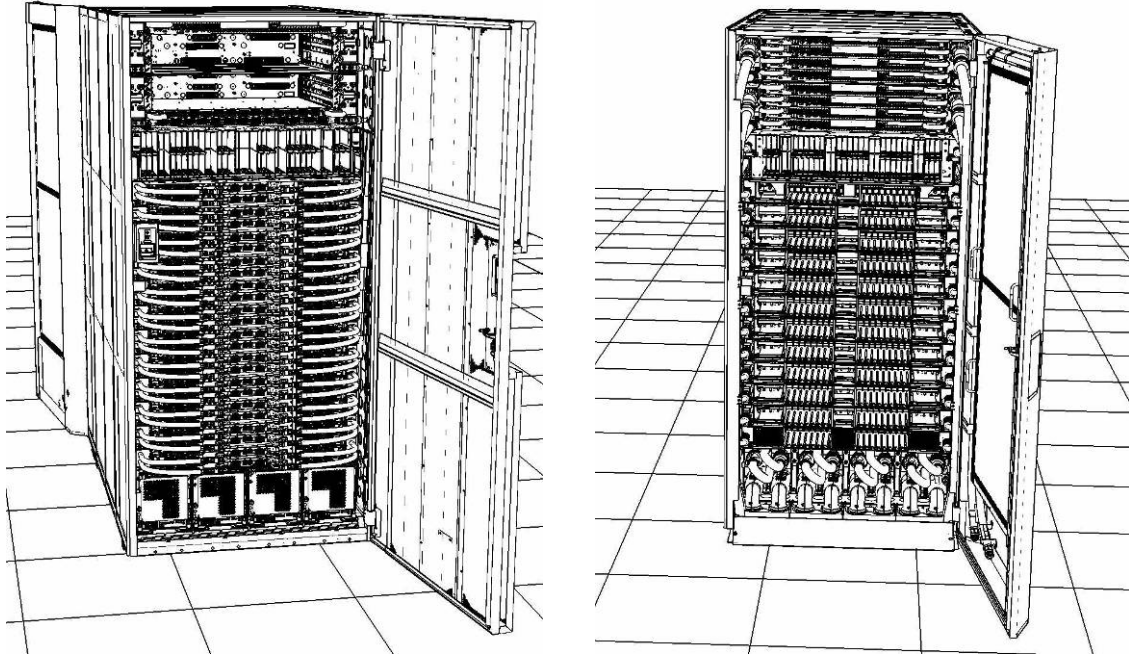
## 8.3 Procedure:

**NOTE:** If you already have the FDT powered on, proceed to **Step 14**. Otherwise, start procedure at **Step 1**.

1. Identify the **Power 775** frame that requires service.

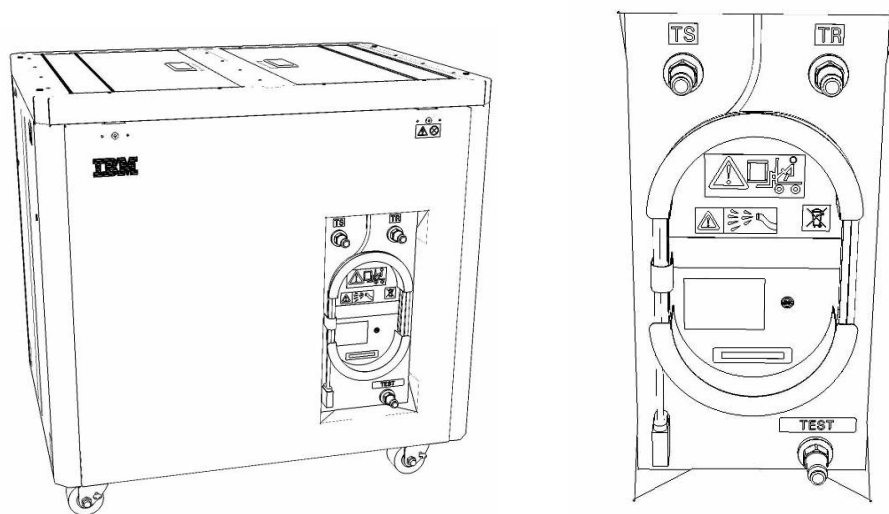
Verify that the system UEPO is set to **ON**, and the managing consoles (HMC and XCat) are powered on and communicating with the frame.

2. Open front and rear doors of the **Power 775** frame that requires service.



3. Bring the FDT to the front side of the **Power 775** frame that requires service.
4. Locate the panel of the FDT that contains the Universal Power and Information Cable (UPIC), as well as the **TS**, **TR**, and **TEST** water connections.

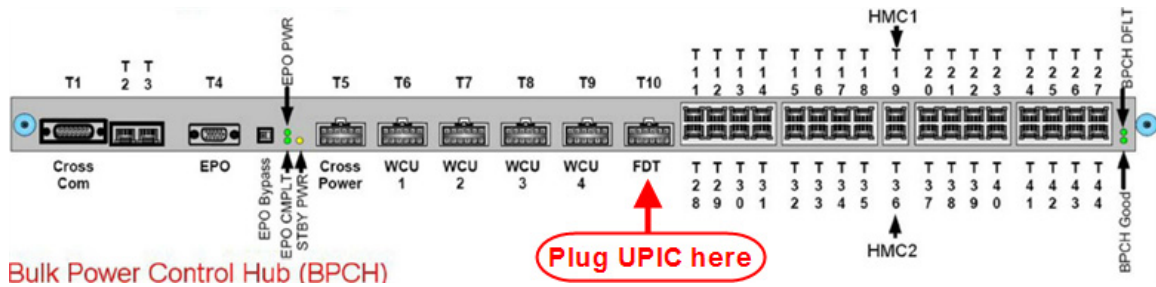
This side of the tool should be facing the front of the frame.



5. Unwrap the FDT UPIC cable from the storage loop on the FDT.

6. Select BPC port for FDT

- If the lower BPA is not targeted for service, and is functional:  
Plug the FDT UPIC cable into **port T10 of the lower BPC**.
- If the lower BPA is targeted for service, or is not functional:  
Plug the FDT UPIC cable into **port T10 of the upper BPC**.



7. Login to the HMC with the User ID `hscroot`.

Use the HMC that is connected to the BPA where the FDT is plugged.

8. From the HMC left Navigation menu, expand **Systems Management** then select **Frames**.

Verify frame serial number for the frame to be serviced.

9. In the **Frames** view on the HMC, place a checkmark in the **Select** column for the frame to be serviced.

10. Verify that the frame **Status** is **Rack Standby/Rack Standby** or **Standby/Standby**.

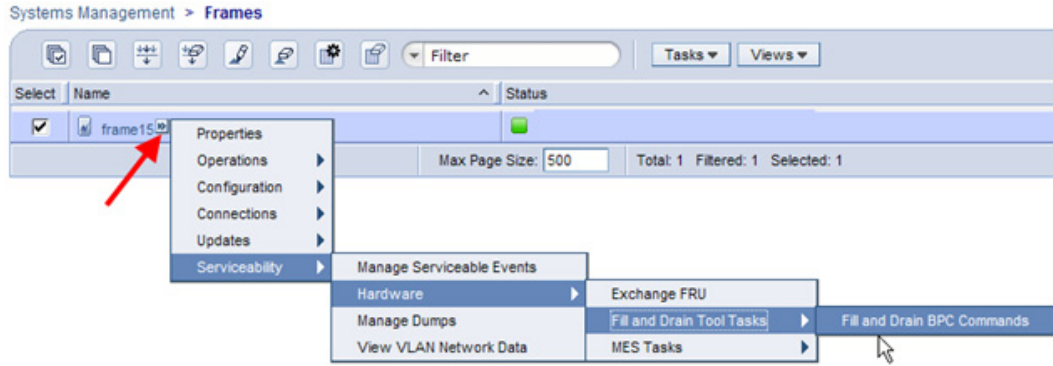
- If frame **Status** reads **Rack Standby/Rack Standby** or **Standby/Standby** – OK.

Continue to next step.

- If frame **Status** does not read **Rack Standby/Rack Standby** or **Standby/Standby** – action required. Contact next level of support.

11. From the **Task** menu on the HMC, *select* **Serviceability** > **Hardware** > **Fill and Drain Tool Tasks** > **Fill and Drain Command Interface**

Power775 Bulk Power Enclosure (BPE) Service Procedure  
 ---- Appendix E: FDT Pressure Calibration Procedure ----



**Fill and Drain Tool Command Interface** will display. See below for a sample image of the interface (FDT deactivated).

**Fill and Drain Tool (FDT) Command Interface - Server-78AC-100BC50029**

The table below shows the FDT Port locations that can communicate with the Fill and Drain Tool. Select the port to which the Fill and Drain Tool is connected. Use the buttons to drive commands to the Fill and Drain Tool connected to a port.

FDT Port Locations:

Select	Location Code	Description
<input type="radio"/>	78AC-100*BC50029-P7-C1	Lower BPC Port T10
<input type="radio"/>	78AC-100*BC50029-P8-C1	Upper BPC Port T10

12. Select the BPC port that the FDT was plugged into in **Step 6** from the **FDT Port Locations:** list.

13. *Click* the **Activate FDT** button.

- If the Activate FDT command is successful – OK. **Wait 30 seconds and continue to next step.**
- If the **Activate FDT** command fails – action required.

*Click* the **Deactivate FDT** button.

Wait 2 minutes and repeat **Step 13**. If the **Activate** command fails again, contact next level of support.

14. *Click* the **Get FDT Status** button.

- If the **Get FDT Status** command is successful – OK.

See below for a sample status (does not reflect expected state)

- If the **Get FDT Status** command fails – action required.

Repeat **Step 14**. If the **Get FDT Status** command fails again, contact next level of support.

**Fill and Drain Tool (FDT) Command Interface - Server-78AC-100BC50029**

The table below shows the FDT Port locations that can communicate with the Fill and Drain Tool. Select the port to which the Fill and Drain Tool is connected. Use the buttons to drive commands to the Fill and Drain Tool connected to a port.

FDT Port Locations:

Select	Location Code	Description
<input checked="" type="radio"/>	78AC-100*BC50029-P7-C1	Lower BPC Port T10
<input type="radio"/>	78AC-100*BC50029-P8-C1	Upper BPC Port T10

FDT Power/Comm: GOOD  
 Frame Attached: IBM Power7 775  
 MDA-FD RL: 45D  
 Error Status: WARNING  
 Tank Level: Full  
 Air Pump: Off  
 Water Pump: DISABLED  
 Tool Mode: Ready  
 Pressure Test Calibration: Incomplete  
 Component Pressure Test: Incomplete

Sample FDT Status

15. Review the FDT status screen and ensure the following status items are OK:

Status Item	State	Action
-------------	-------	--------

- **Tool Mode:** **Ready** – OK. Check next Status item.
- **Error Status:** **NONE** – OK. Check next Status item.  
**WARNING** – *click* the **Decode Error Status** button, record the information returned and check Tank Level.  
**CRITICAL** – *click* the **Decode Error Status** button, record the information returned and contact next level of support.



- **Tank Level:** **Upper Half, Lower Half** or **Empty** – OK. Check next Status item.  
**Full** – action required.  
Exit this procedure and perform the **Power 775 Fill and Drain Tool (FDT) Tank Drain Procedure**.  
Once FDT tank level is **Upper Half, Lower Half** or **Empty**, return to this step and continue with procedure.
- **Pressure Test Calibration:** **Incomplete** - OK. Proceed to next step.  
**Pass** or **Fail** – action required.  
*Click the **Deactivate FDT** button.*  
Repeat **Step 13** and continue with procedure.

16. Before proceeding, read required safety information:

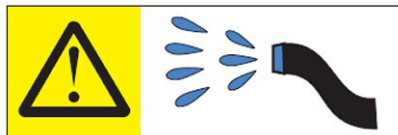
**CAUTION:** The water-based coolant solution may contain an additive intended to inhibit corrosion (or provide other functions). The solution may cause irritation to the skin or eyes. Avoid direct contact with the solution. Employ appropriate Personal Protective Equipment when performing operations involving the coolant or which may potentially expose you to the coolant. Refer to the MSDS for more information. (C037)



**CAUTION:** Protective eyewear is needed for the procedure. (L011)

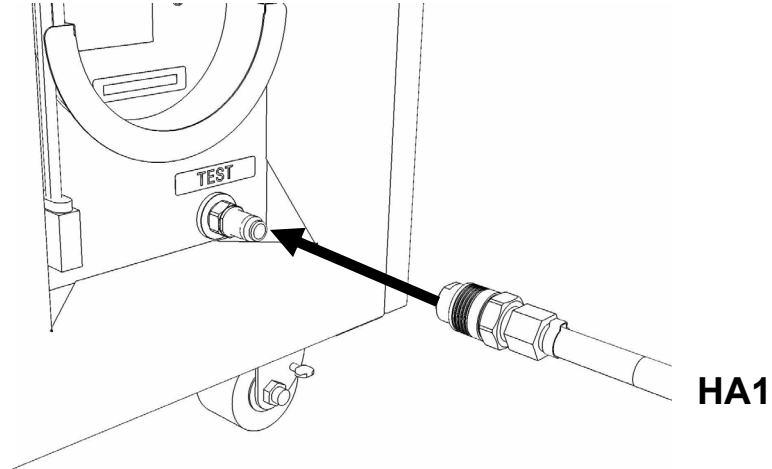


**CAUTION:** Chemical resistant gloves are needed for this procedure. (L014)

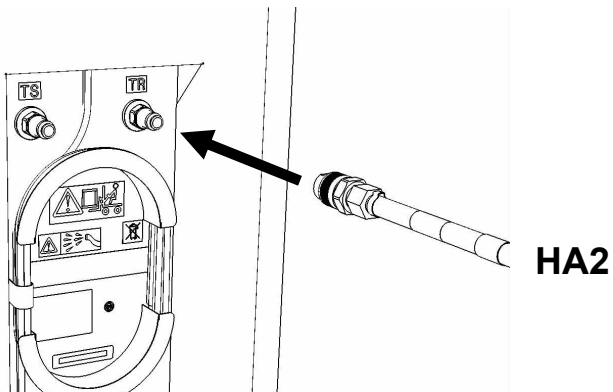


**DANGER:** Risk of electric shock due to water or a water solution which is present in this product. Avoid working on or near energized equipment with wet hands or when spilled water is present. (L016)

17. Remove hose assembly **HA1** from the upper tool storage compartment.  
Connect either end of hose assembly **HA1** to the **TEST** connection on the front panel of the FDT.

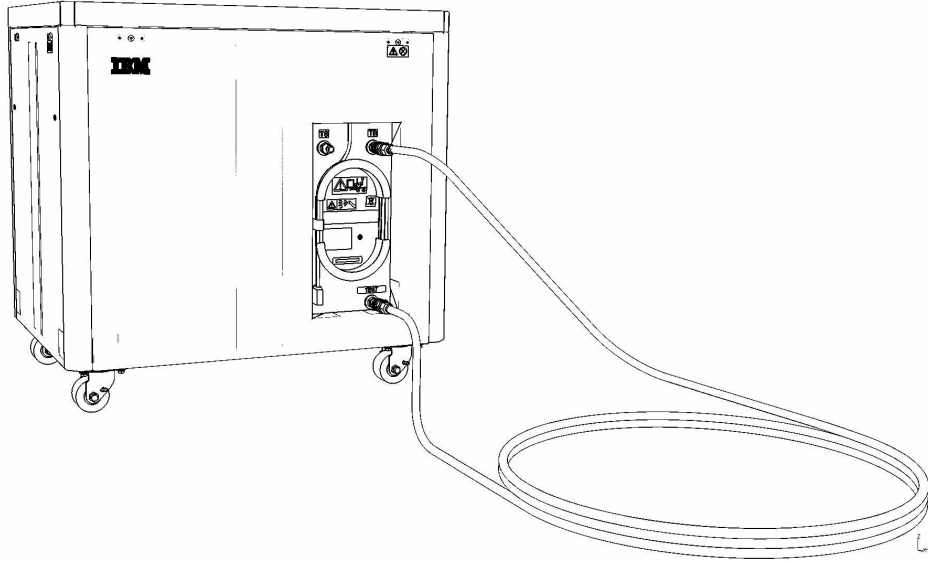


18. Remove hose assembly **HA2** from the upper tool storage compartment.  
Connect the end *without sight glass* to the TR connection on the FDT.

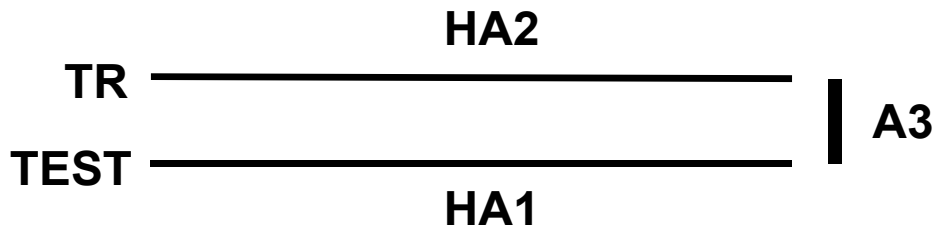


19. Remove adapter **A3** from the FDT.  
Connect the free ends of **HA1** and **HA2** together via adapter **A3**.

Place excess hose on floor in front of FDT.



20. Ensure all water connections are made properly and securely.



21. On the FDT panel, *click* the **Pressure Test Calibration** button.

The **Get FDT Status** button may be *clicked* to examine FDT status.

**NOTE:** *The pressure testing will last for 1 minute (30 seconds with air pump on)*

**CAUTION:** *This unit must not be left running unattended, service personnel should always be overseeing the process. (C038)*

22. *Click* the **Get FDT Status** button and review the following:

- **Tool mode:**     **Ready** – OK. Check Error Status.

**Pressure Test Calibration Mode** – pressure test still running.

Wait 30 seconds and repeat **Step 22**.

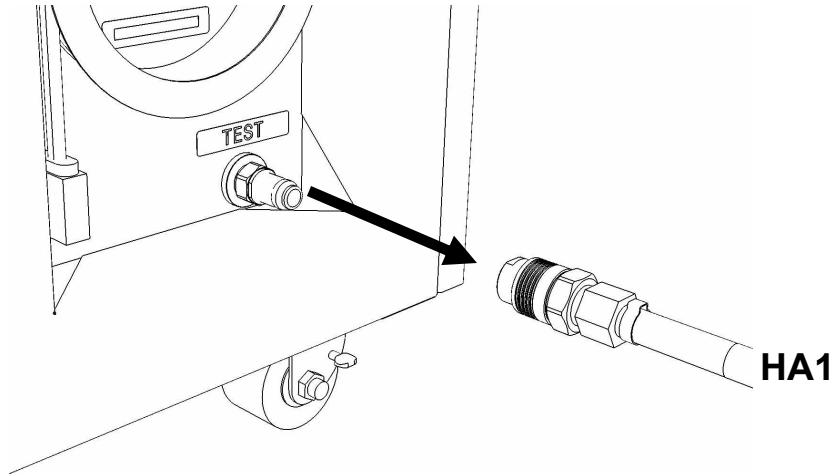
- **Error Status:** **NONE** – OK. Check Pressure Test Calibration.  
**WARNING** – *click* the **Decode Error Status** button, record information returned and proceed to next step.  
**CRITICAL** – *click* the **Decode Error Status** button, record information returned and contact next level of support.
- **Pressure Test Calibration:** **Pass** – OK. Proceed to next step.  
**Fail or Incomplete** – action required.  
*Click* the **Reset FDT** button.  
Repeat **Step 17** and continue with procedure.  
If the test read **Fail** twice, hardware is defective. Contact next level of support.

23. The FDT Pressure Test Calibration has passed successfully.

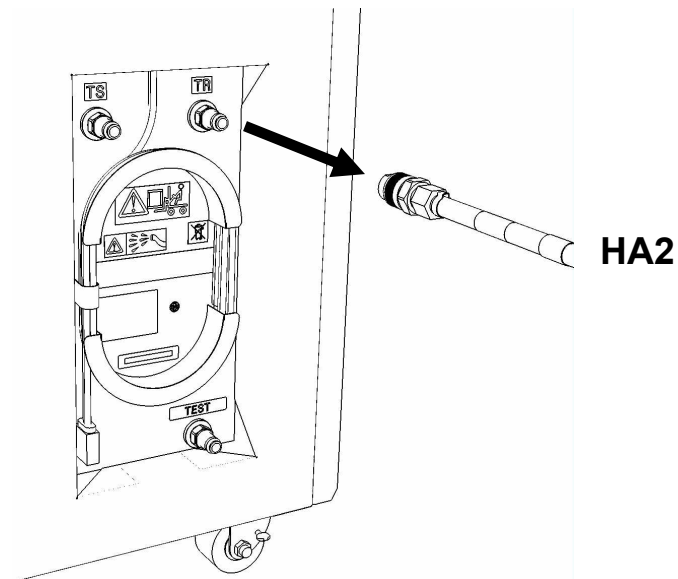
**NOTE:** *If a Component Pressure Test procedure will be completed following this test, disregard Step 25 – 26. These hose connections will be the same in the component pressure test procedure.*

24. Disconnect hose assemblies **HA1** and **HA2** from adapter **A3**.

25. Disconnect the FDT end of **HA1** from **TS** on the FDT.



26. Disconnect the FDT end of **HA2** from **TR** on the FDT.



27. Place all hose assemblies and adapters in their appropriate locations within the FDT storage enclosure.

28. Determine whether the FDT will be used for another procedure:

- If the FDT will be used for another procedure, leave tool activated and go to that procedure now; skip the remaining steps of this procedure.
- If the FDT requires no further use - proceed to the next step.

29. *Click* the **Deactivate FDT** button.

- If the **Deactivate FDT** command is successful – OK. Proceed to next step.
- If the **Deactivate FDT** command fails– action required.

Repeat **Deactivate FDT**. If the **Deactivate FDT** command fails again, contact next level of support.

30. Disconnect FDT UPIC power cable from port T10 of BPC used.

Wrap the UPIC cable in appropriate cable storage location on FDT.

31. If this procedure was referenced from another procedure, return to parent procedure.

---

## 8.4 End of Appendix E: Power775 Fill and Drain Tool (FDT) Pressure Test Calibration Procedure

---

## 9 APPENDIX F: POWER775 FILL AND DRAIN TOOL (FDT) TANK FILL PROCEDURE

### 9.1 Safety Notices

Read “Safety Notices“ available from InfoCenter:

<http://publib.boulder.ibm.com/infocenter/powersys/v3r1m5/topic/p7hdx/G229-9054.pdf>

The following cautions apply to all Power775 service procedures:

**CAUTION:**

Energy hazard present and Shorting might result in system outage and possible physical injury. Remove all metallic jewelry before servicing. (C001)

**CAUTION:**

The doors and covers to the product are to be closed at all times except for service by trained service personnel. All covers must be replaced and doors locked at the conclusion of the service operation. (C013)

**CAUTION:**

Service of this product or unit is to be performed by trained service personnel only. (C032)

The following notices specifically pertain to this Power775 service procedure.

**CAUTION:** The water-based coolant solution may contain an additive intended to inhibit corrosion (or provide other functions). The solution may cause irritation to the skin or eyes. Avoid direct contact with the solution. Employ appropriate Personal Protective Equipment when performing operations involving the coolant or which may potentially expose you to the coolant. Refer to the MSDS for more information. (C037)

**CAUTION:** This unit must not be left running unattended, service personnel should always be overseeing the process. (C038)



**DANGER:** Hazardous voltage present. Voltages present constitute a shock hazard, which can cause severe injury or death. (L004)



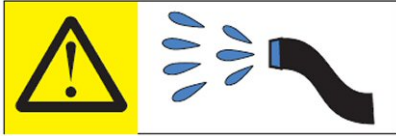
**CAUTION:** Protective eyewear is needed for the procedure. (L011)



**DANGER:** Heavy equipment—personal injury or equipment damage might result if mishandled. (L013)



**CAUTION:** Chemical resistant gloves are needed for this procedure. (L014)



**DANGER:** Risk of electric shock due to water or a water solution which is present in this product. Avoid working on or near energized equipment with wet hands or when spilled water is present. (L016)



## 9.2 Background:

This document contains the procedure for filling an **IBM Power 775** Fill and Drain Tool (FDT) tank (internal reservoir).

The FDT is used to transfer water into and out of various components of the **IBM Power 775** system. When a system component or the entire system is filled, the water will be transferred from the tank (internal reservoir) within the FDT to the component or system. During fill operations, the FDT tank may become empty, and if so, will need to be periodically filled using the supplied system water containers. Individual system water containers treated with a corrosion inhibitor are shipped with the system. The FDT Tank Fill Procedure instructs the user to properly transfer water out of a full system water container into the FDT Tank.

During system or component filling operations, if the FDT senses that the internal reservoir has become empty, it will terminate any running fill routine, as well as prevent any further fill routines from being executed. This may occur during a system or component fill procedure; if so, the system or component fill procedure must be paused, and this FDT Tank Fill Procedure must be completed before system/component filling can resume.

**The system water is treated and must not be poured down a sink or on the ground.**

### **Reference Information:**

**IBM Power 775** FDT P/N: **45D6928**  
**IBM** System Water Container P/N: **45D2124** (U.S.), **45D2129** (non-U.S.)  
Hose assemblies/adapters required: **THA** (45D8563)

Approximate FDT internal water volume: 32 L  
Expected filling time for one (1) system water container: 1 min, 30 s

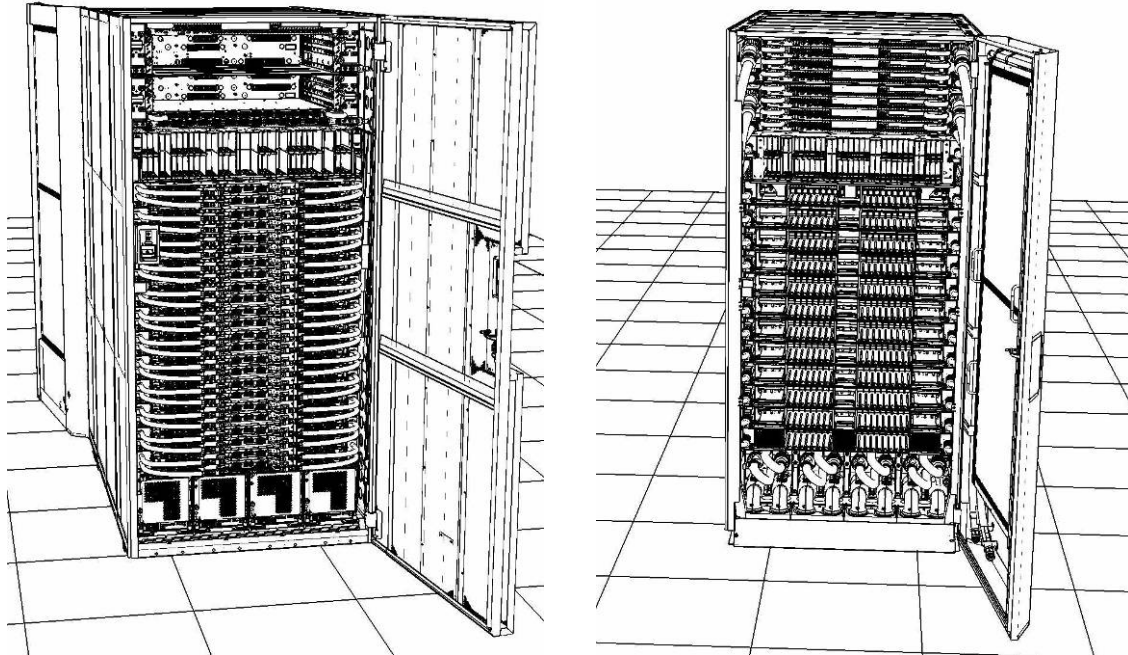
**NOTE:** *Some steps in this procedure may be redundant due to other service operations being completed prior to this procedure. If a step has already been completed, verify that the step has been completed properly and proceed to the next step.*

---

## 9.3 Procedure:

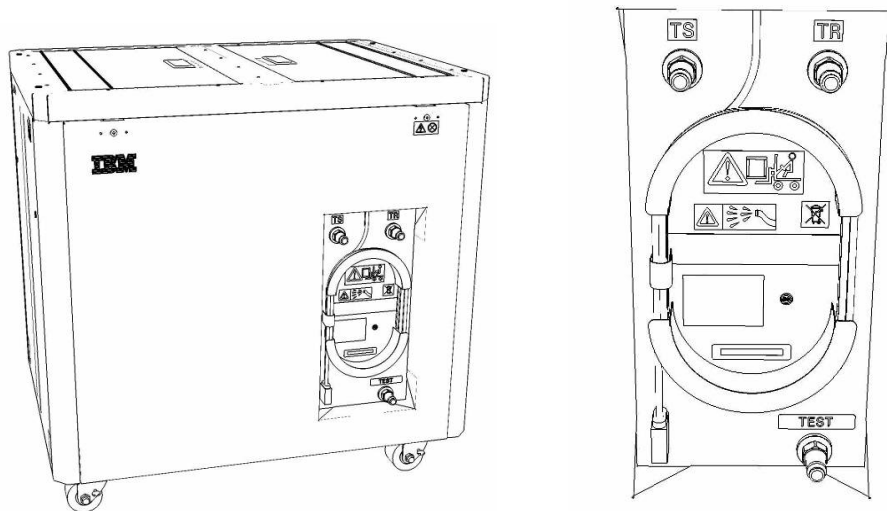
**NOTE:** If you already have the FDT powered on, proceed to **Step 14**. Otherwise, start procedure at **Step 1**.

1. Identify the **Power 775** frame that requires service.  
Verify that the system UEPO is set to **ON**, and the managing consoles (HMC and XCat) are powered on and communicating with the frame.
2. Open front and rear doors of the **Power 775** frame that requires service.

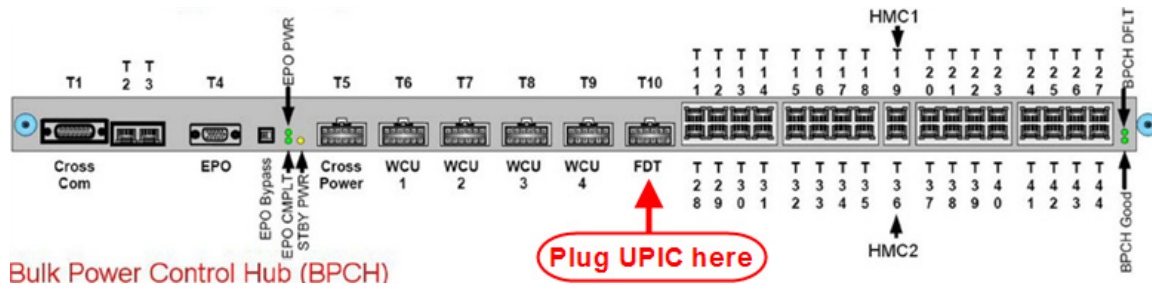


3. Bring the FDT to the front side of the **Power 775** frame that requires service.
4. Locate the panel of the FDT that contains the Universal Power and Information Cable (UPIC), as well as the **TS**, **TR**, and **TEST** water connections.

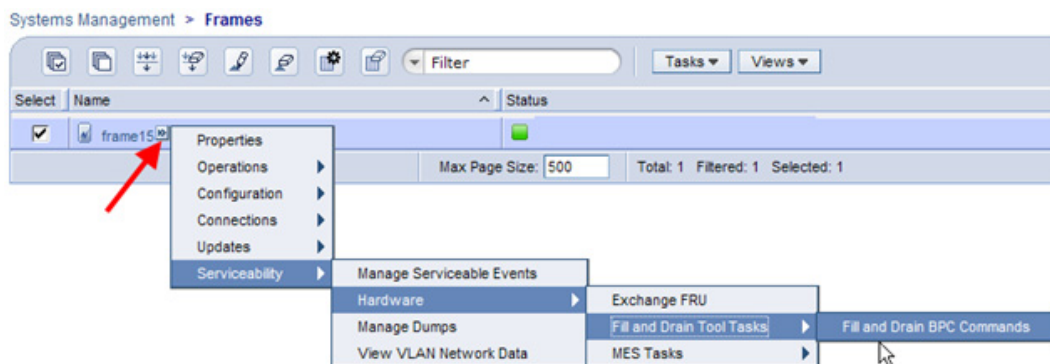
This side of the tool should be facing the front of the frame.



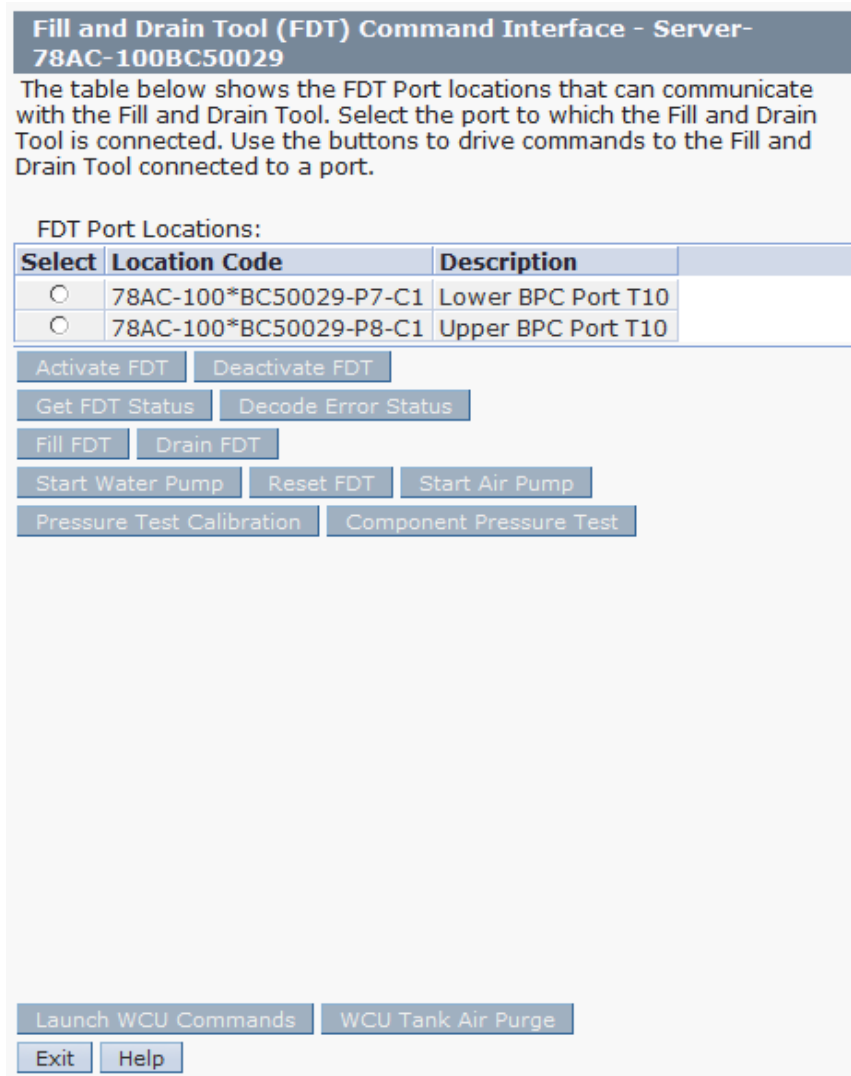
5. Unwrap the FDT UPIC cable from the storage loop on the FDT.
6. Select BPC port for FDT
  - If the lower BPA is not targeted for service, and is functional:  
Plug the FDT UPIC cable into **port T10 of the lower BPC**.
  - If the lower BPA is targeted for service, or is not functional:  
Plug the FDT UPIC cable into **port T10 of the upper BPC**.



7. Login to the HMC with the User ID `hscroot`.  
Use the HMC that is connected to the BPA where the FDT is plugged.
8. From the HMC left Navigation menu, expand **Systems Management** then select **Frames**.  
Verify frame serial number for the frame to be serviced.
9. In the **Frames** view on the HMC, place a checkmark in the **Select** column for the frame to be serviced.
10. Verify that the frame **Status** is **Rack Standby/Rack Standby** or **Standby/Standby**.
  - If frame **Status** reads **Rack Standby/Rack Standby** or **Standby/Standby** – OK.  
Continue to next step.
  - If frame **Status** does not read **Rack Standby/Rack Standby** or **Standby/Standby** – action required. Contact next level of support.
11. From the **Task** menu on the HMC, select **Serviceability** > **Hardware** > **Fill and Drain Tool Tasks** > **Fill and Drain Command Interface**



**Fill and Drain Tool Command Interface** will display. See below for a sample image of the interface (FDT deactivated).



12. Select the BPC port that the FDT was plugged into in **Step 6** from the **FDT Port Locations:** list.

13. *Click* the **Activate FDT** button.

- If the Activate FDT command is successful – OK. **Wait 30 seconds and continue to next step.**
- If the **Activate FDT** command fails – action required.

*Click* the **Deactivate FDT** button.

Wait 2 minutes and repeat **Step 13**. If the **Activate** command fails again, contact next level of support.

14. Click the **Get FDT Status** button.

- If the **Get FDT Status** command is successful – OK.  
See below for a sample status (does not reflect expected state)

- If the **Get FDT Status** command fails – action required.

Repeat **Step 14**. If the **Get FDT Status** command fails again, contact next level of support.

**Fill and Drain Tool (FDT) Command Interface - Server-78AC-100BC50029**

The table below shows the FDT Port locations that can communicate with the Fill and Drain Tool. Select the port to which the Fill and Drain Tool is connected. Use the buttons to drive commands to the Fill and Drain Tool connected to a port.

FDT Port Locations:

Select	Location Code	Description
<input checked="" type="radio"/>	78AC-100*BC50029-P7-C1	Lower BPC Port T10
<input type="radio"/>	78AC-100*BC50029-P8-C1	Upper BPC Port T10

Activate FDT   Deactivate FDT  
Get FDT Status   Decode Error Status  
Fill FDT   Drain FDT  
Start Water Pump   Reset FDT   Start Air Pump  
Pressure Test Calibration   Component Pressure Test

FDT Power/Comm: GOOD  
Frame Attached: IBM Power7 775  
MDA-FD RL: 45D  
Error Status: WARNING  
Tank Level: Full  
Air Pump: Off  
Water Pump: DISABLED  
Tool Mode: Ready  
Pressure Test Calibration: Incomplete  
Component Pressure Test: Incomplete

Launch WCU Commands   WCU Tank Air Purge  
Exit   Help

A blue arrow points from the text 'Sample FDT Status' to the status information area of the screenshot.

Sample FDT Status

15. Review the FDT status screen and ensure the following status items are OK:

Status Item	State	Action
• <b>Tool Mode:</b>	<b>Ready</b>	– OK. Check next Status item.
• <b>Error Status:</b>	<b>NONE</b>	– OK. Check next Status item.  <b>WARNING</b> – <i>click</i> the <b>Decode Error Status</b> button, record the information returned and check Tank Level.  <b>CRITICAL</b> – <i>click</i> the <b>Decode Error Status</b> button, record the information returned and contact next level of support.
• <b>Tank Level:</b>	<b>Lower Half</b> or <b>Empty</b>	– OK.  Note tank level, and proceed to next step.  <b>Upper Half</b> or <b>Full</b> – FDT should not be filled.  Exit procedure.

16. Locate a full system water container.

Transport the container to the location of the FDT.

Do not place the container between the FDT and the open frame.

**NOTE:** Use of a non-full system water container will result in repeated FDT filling operations.

IBM PN **45D2124** (U.S.), **45D2129** (non-U.S.).

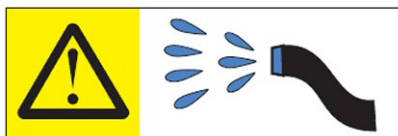
**CAUTION:** The water-based coolant solution may contain an additive intended to inhibit corrosion (or provide other functions). The solution may cause irritation to the skin or eyes. Avoid direct contact with the solution. Employ appropriate Personal Protective Equipment when performing operations involving the coolant or which may potentially expose you to the coolant. Refer to the MSDS for more information. (C037)



**CAUTION:** Protective eyewear is needed for the procedure. (L011)

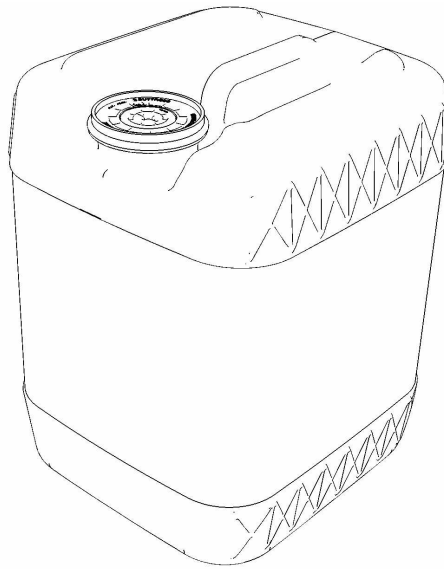


**CAUTION:** Chemical resistant gloves are needed for this procedure. (L014)

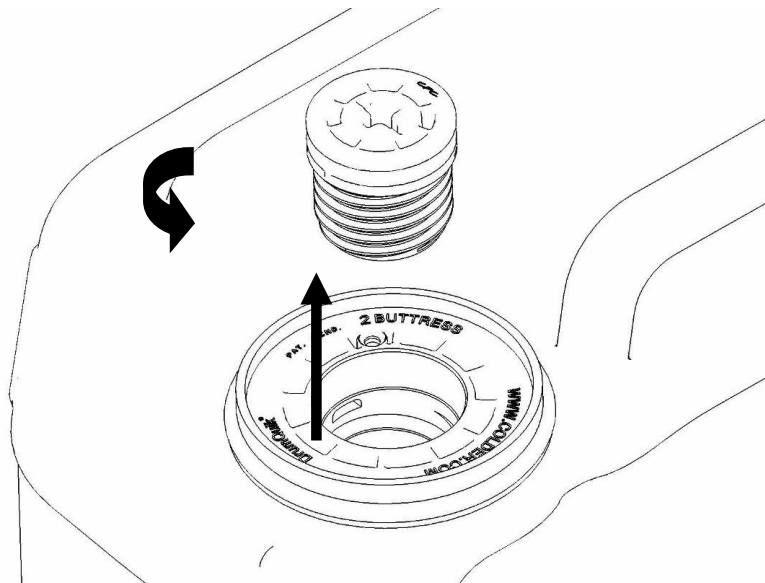


**DANGER:** Risk of electric shock due to water or a water solution which is present in this product. Avoid working on or near energized equipment with wet hands or when spilled water is present. (L016)

The system water is treated and must not be poured down a sink or on the ground.

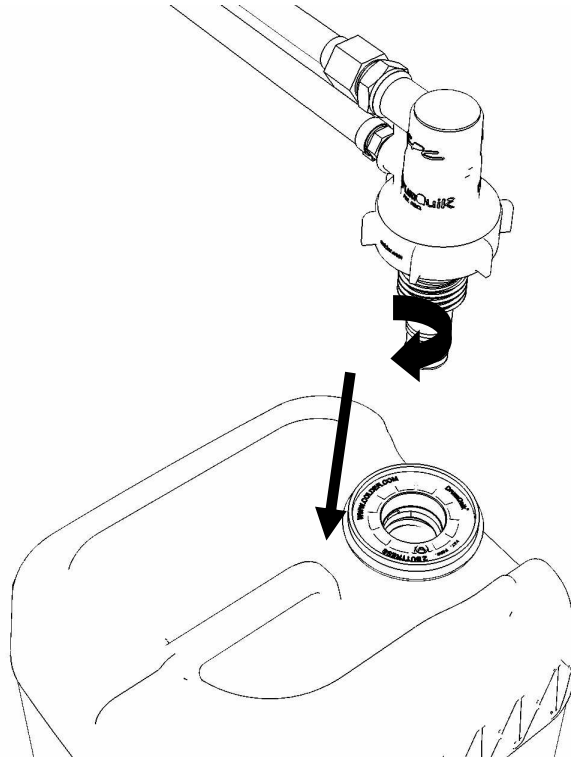


17. Remove the inner cap from the white system water container insert.  
Unthread inner cap counter-clockwise with a large screwdriver.

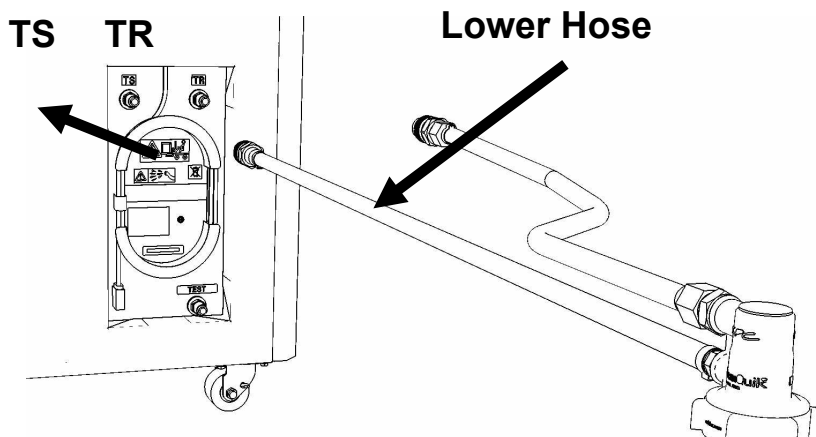


18. Remove transfer hose assembly **THA** from the upper tool storage compartment.

19. Insert large white threaded insert of **THA** into the system water container.  
Turn clockwise until hand tight.

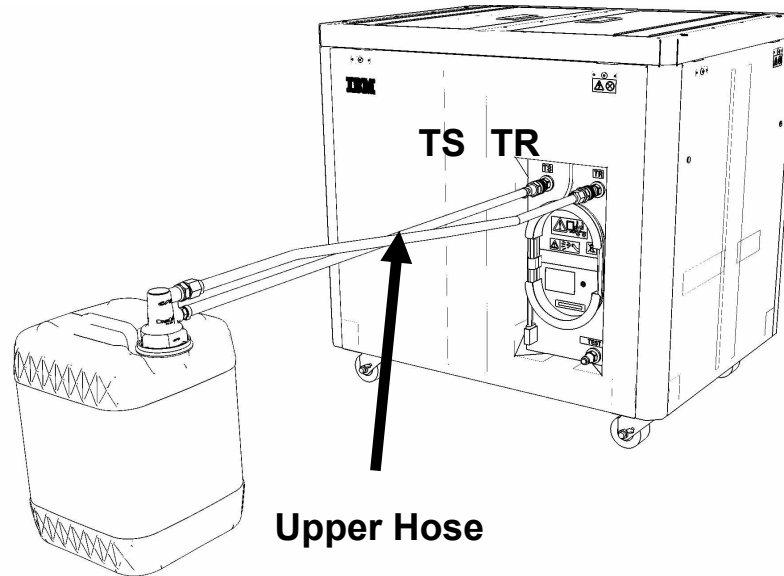


20. Connect the **Lower THA Hose** to the **TS** connection on the front panel of the FDT.

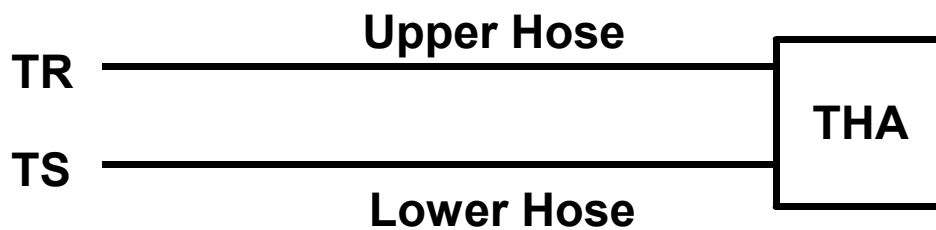




21. Connect the **Upper THA Hose** to the **TR** connection on the front panel of the FDT.



22. Ensure all water connections are made properly and securely.



23. On the FDT panel, *click* the **Fill FDT** button.

The **Get FDT Status** button may be *clicked* to examine FDT status.

**NOTE:** *The air pump will shut off after 1 minute, 40 seconds of run time.*

**CAUTION:** **This unit must not be left running unattended, service personnel should always be overseeing the process. (C038)**

24. Verify that the container feels empty after FDT fill.

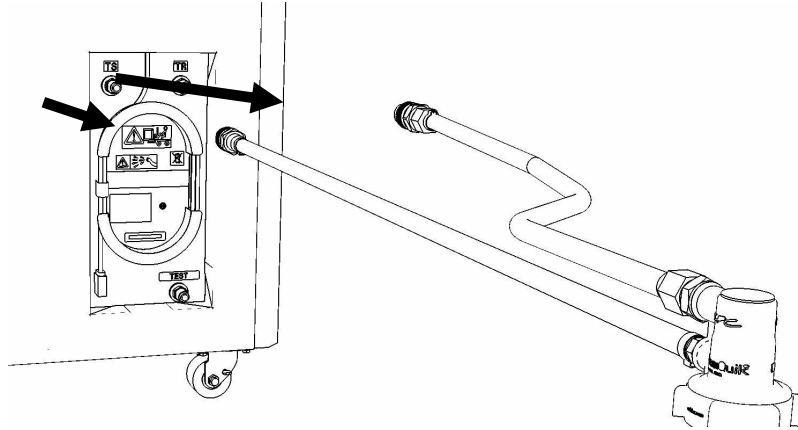
Container will weigh approximately 5 lbs. (2 kg) when empty.

- If container feels empty, proceed to **Step 25**.
- If container does not feel empty, repeat **Step 20** and continue with procedure.

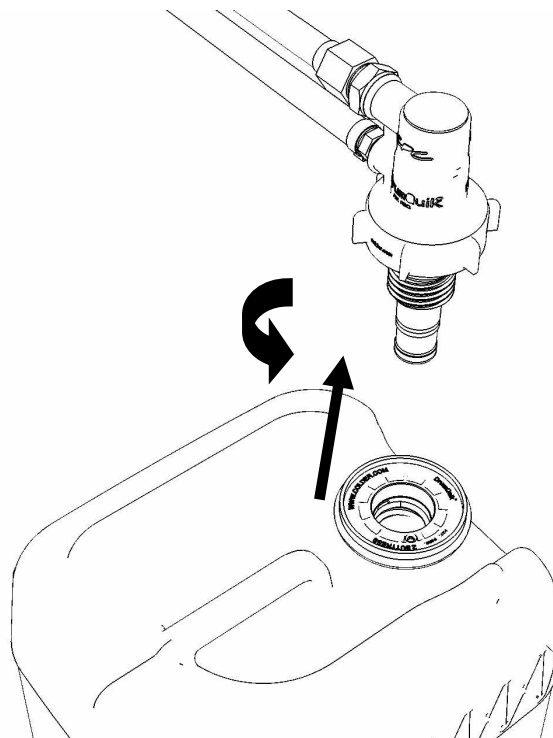
25. Click the **Get FDT Status** button and ensure the following status items are OK:

Status Item	State	Action
• <b>Tool mode:</b>	<b>Ready</b> – OK. Check next Status item. <b>FDT Fill Mode</b> – air pump still running. Wait 30 seconds and repeat <b>Step 25</b> .	
• <b>Error Status:</b>	<b>NONE</b> – OK. Check next Status item. <b>WARNING</b> – <i>click</i> the <b>Decode Error Status</b> button, record information returned and proceed to next step. <b>CRITICAL</b> – <i>click</i> the <b>Decode Error Status</b> button, record information returned and contact next level of support.	
• <b>Tank Level:</b>	Repeat <b>Step 16</b> to <b>Step 25</b> (with additional full container) until desired level is reached. If tank level does not rise, repeat <b>Step 16</b> through <b>Step 25</b> . If tank level does not increase after repeat, contact next level of support.	

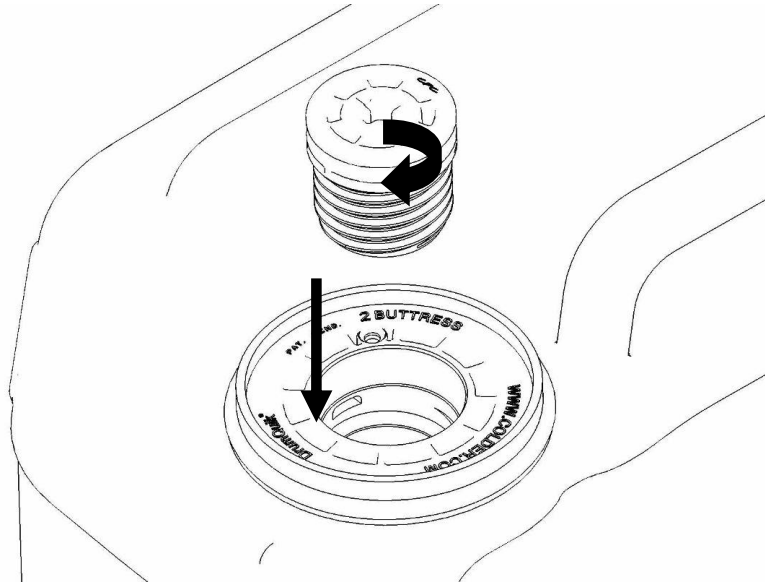
26. Disconnect the **Lower THA Hose** from the **TS** connection on the front panel of the FDT.
27. Disconnect the **Upper THA Hose** from the **TR** connection on the front panel of the FDT.



28. Remove large white threaded insert of **THA** from the system water container.  
Turn **slowly** counterclockwise until removed.  
Some residual pressure may remain on the system water container



29. Replace the inner cap into the white system water container insert.  
Turn inner cap clockwise with a large screwdriver.



30. Place all hose assemblies and adapters in their appropriate locations within the FDT storage enclosure.
31. Determine whether the FDT will be used for another procedure:
- If the FDT will be used for another procedure, leave tool activated and go to that procedure now; skip the remaining steps of this procedure.
  - If the FDT requires no further use - proceed to the next step.
32. Click the **Deactivate FDT** button.
- If the **Deactivate FDT** command is successful – OK. Proceed to next step.
  - If the **Deactivate FDT** command fails– action required.  
Repeat **Deactivate FDT**. If the **Deactivate FDT** command fails again, contact next level of support.
33. Disconnect FDT UPIC power cable from port T10 of BPC used.  
Wrap the UPIC cable in appropriate cable storage location on FDT.
34. If this procedure was referenced from another procedure, return to parent procedure.

## **9.4 End of Appendix F: Power775 Fill and Drain Tool (FDT) Tank Fill Procedure**

---

---

# 10 APPENDIX G: POWER775 FILL AND DRAIN TOOL (FDT) TANK DRAIN PROCEDURE

---

## 10.1 Safety Notices

Read “Safety Notices“ available from InfoCenter:

<http://publib.boulder.ibm.com/infocenter/powersys/v3r1m5/topic/p7hdx/G229-9054.pdf>

The following cautions apply to all Power775 service procedures:

**CAUTION:**

Energy hazard present and Shorting might result in system outage and possible physical injury. Remove all metallic jewelry before servicing. (C001)

**CAUTION:**

The doors and covers to the product are to be closed at all times except for service by trained service personnel. All covers must be replaced and doors locked at the conclusion of the service operation. (C013)

**CAUTION:**

Servicing of this product or unit is to be performed by trained service personnel only. (C032)

The following notices specifically pertain to this Power775 service procedure.

**CAUTION:** The water-based coolant solution may contain an additive intended to inhibit corrosion (or provide other functions). The solution may cause irritation to the skin or eyes. Avoid direct contact with the solution. Employ appropriate Personal Protective Equipment when performing operations involving the coolant or which may potentially expose you to the coolant. Refer to the MSDS for more information. (C037)

**CAUTION:** This unit must not be left running unattended, service personnel should always be overseeing the process. (C038)



**DANGER:** Hazardous voltage present. Voltages present constitute a shock hazard, which can cause severe injury or death. (L004)



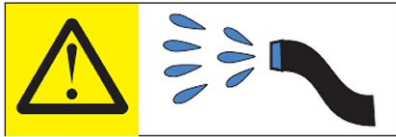
**CAUTION:** Protective eyewear is needed for the procedure. (L011)



**DANGER:** Heavy equipment—personal injury or equipment damage might result if mishandled.  
(L013)



**CAUTION:** Chemical resistant gloves are needed for this procedure. (L014)



**DANGER:** Risk of electric shock due to water or a water solution which is present in this product. Avoid working on or near energized equipment with wet hands or when spilled water is present.  
(L016)

## 10.2 Background:

This document contains the procedure for draining the water out of the internal reservoir of an **IBM Power 775** Fill and Drain Tool (FDT).

The FDT is used to transfer water into and out of various components of the **IBM Power 775** system. When a system component or the entire system is drained, the water will be transferred into the tank (internal reservoir) within the FDT. During drain operations, the FDT tank may become full, and if so, will need to be periodically emptied into the supplied system water containers. The FDT Tank Drain Procedure instructs the user to properly transfer water out of the FDT Tank and into an empty system water container.

During system or component drain operations, if the FDT senses that the internal reservoir has become full, it will terminate any running drain routine, as well as prevent any further drain routines from being executed. This may occur during a system or component drain procedure; if so, the system or component drain procedure must be paused, and this FDT Tank Drain Procedure must be completed before system/component draining can resume. Individual system water containers treated with a corrosion inhibitor are shipped with the system and after the initial system fill, the empty containers must be stored to be available for the FDT Tank Drain operation.

**The system water is treated and must not be poured down a sink or on the ground.**

### **Reference Information:**

**IBM Power 775** FDT P/N: **45D6928**  
**IBM** System Water Container P/N: **45D2124** (U.S.), **45D2129** (non-U.S.)  
Hose assemblies/adapters required: **THA** (45D8563)

Approximate FDT internal water volume: 32 L

Expected drainage time for one (1) system water container: 1 min, 40 s

**NOTE:** *Some steps in this procedure may be redundant due to other service operations being completed prior to this procedure. If a step has already been completed, verify that the step has been completed properly and proceed to the next step.*

---

## 10.3 Procedure:

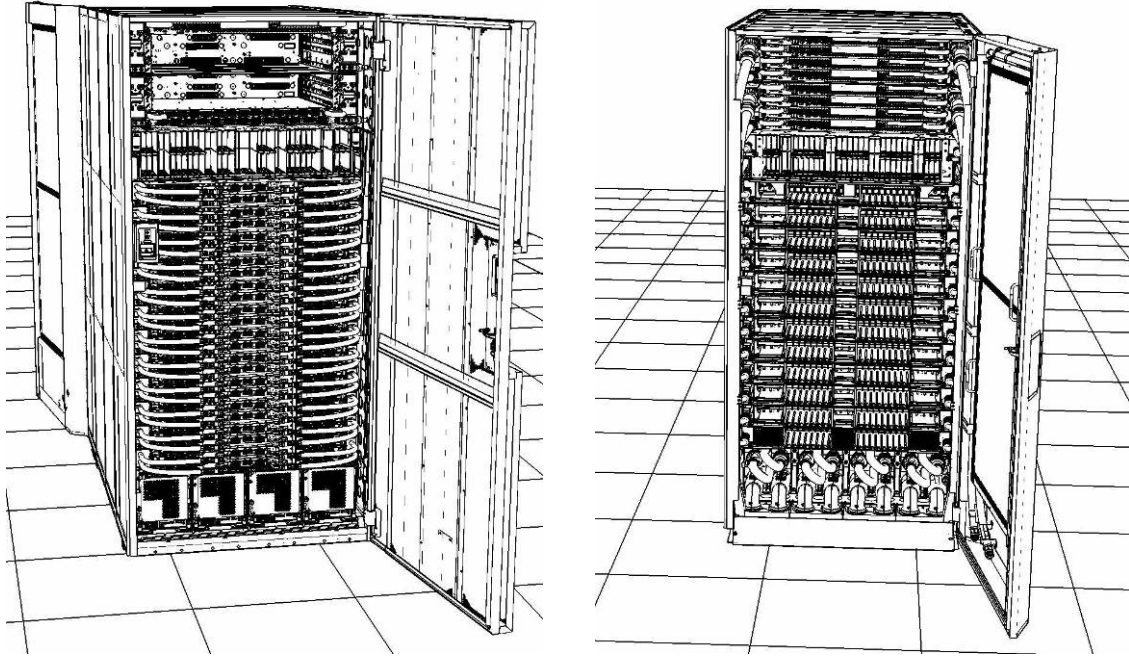
**NOTE:** If you already have the FDT powered on, proceed to **Step 14**. Otherwise, start procedure at **Step 1**.



1. Identify the **Power 775** frame that requires service.

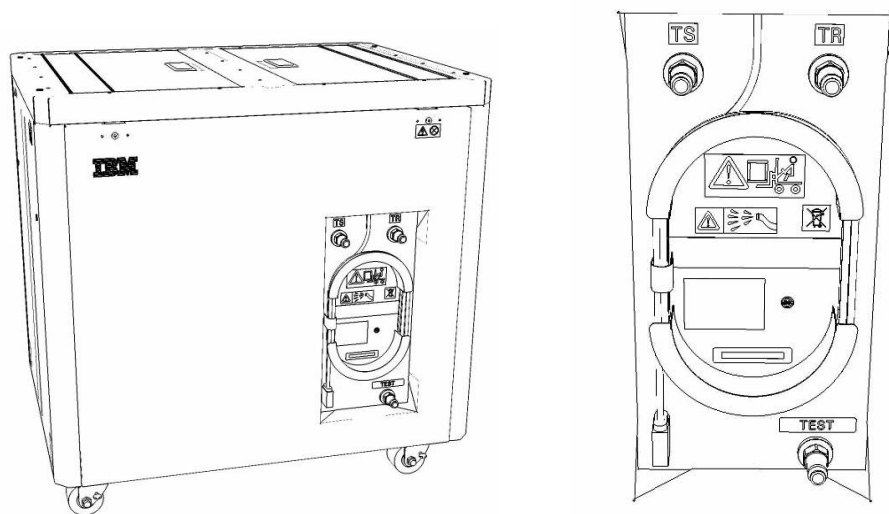
Verify that the system UEPO is set to **ON**, and the managing consoles (HMC and XCat) are powered on and communicating with the frame.

2. Open front and rear doors of the **Power 775** frame that requires service.



3. Bring the FDT to the front side of the **Power 775** frame that requires service.
4. Locate the panel of the FDT that contains the Universal Power and Information Cable (UPIC), as well as the **TS**, **TR**, and **TEST** water connections.

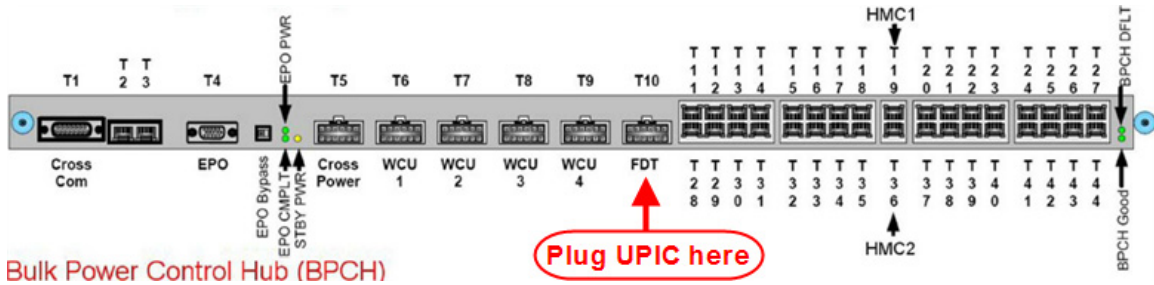
This side of the tool should be facing the front of the frame.



5. Unwrap the FDT UPIC cable from the storage loop on the FDT.

6. Select BPC port for FDT

- If the lower BPA is not targeted for service, and is functional:  
 Plug the FDT UPIC cable into **port T10 of the lower BPC**.
- If the lower BPA is targeted for service, or is not functional:  
 Plug the FDT UPIC cable into **port T10 of the upper BPC**.



7. Login to the HMC with the User ID `hscroot`.

Use the HMC that is connected to the BPA where the FDT is plugged.

8. From the HMC left Navigation menu, expand **Systems Management** then select **Frames**.

Verify frame serial number for the frame to be serviced.

9. In the **Frames** view on the HMC, place a checkmark in the **Select** column for the frame to be serviced.

10. Verify that the frame **Status** is **Rack Standby/Rack Standby** or **Standby/Standby**.

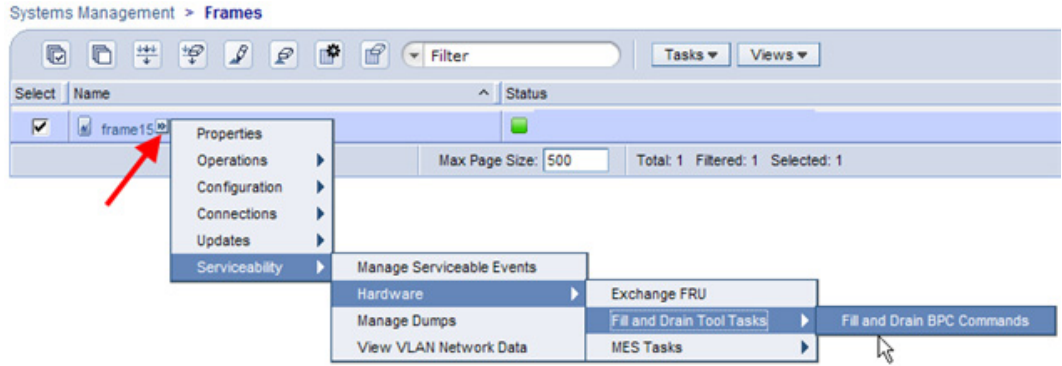
- If frame **Status** reads **Rack Standby/Rack Standby** or **Standby/Standby** – OK.

Continue to next step.

- If frame **Status** does not read **Rack Standby/Rack Standby** or **Standby/Standby** – action required. Contact next level of support.

11. From the **Task** menu on the HMC, *select* **Serviceability** > **Hardware** > **Fill and Drain Tool Tasks** > **Fill and Drain Command Interface**

Power775 Bulk Power Enclosure (BPE) Service Procedure  
 ---- Appendix G: FDT Tank Drain Procedure ----



**Fill and Drain Tool Command Interface** will display. See below for a sample image of the interface (FDT deactivated).

**Fill and Drain Tool (FDT) Command Interface - Server-78AC-100BC50029**

The table below shows the FDT Port locations that can communicate with the Fill and Drain Tool. Select the port to which the Fill and Drain Tool is connected. Use the buttons to drive commands to the Fill and Drain Tool connected to a port.

FDT Port Locations:

Select	Location Code	Description
<input type="radio"/>	78AC-100*BC50029-P7-C1	Lower BPC Port T10
<input type="radio"/>	78AC-100*BC50029-P8-C1	Upper BPC Port T10

12. Select the BPC port that the FDT was plugged into in **Step 6** from the **FDT Port Locations:** list.

13. *Click* the **Activate FDT** button.

- If the Activate FDT command is successful – OK. **Wait 30 seconds and continue to next step.**
- If the **Activate FDT** command fails – action required.

*Click* the **Deactivate FDT** button.

Wait 2 minutes and repeat **Step 13**. If the **Activate** command fails again, contact next level of support.

14. *Click* the **Get FDT Status** button.

- If the **Get FDT Status** command is successful – OK.  
See below for a sample status (does not reflect expected state)
- If the **Get FDT Status** command fails – action required.

Repeat **Step 14**. If the **Get FDT Status** command fails again, contact next level of support.

**Fill and Drain Tool (FDT) Command Interface - Server-78AC-100BC50029**

The table below shows the FDT Port locations that can communicate with the Fill and Drain Tool. Select the port to which the Fill and Drain Tool is connected. Use the buttons to drive commands to the Fill and Drain Tool connected to a port.

FDT Port Locations:

Select	Location Code	Description
<input checked="" type="radio"/>	78AC-100*BC50029-P7-C1	Lower BPC Port T10
<input type="radio"/>	78AC-100*BC50029-P8-C1	Upper BPC Port T10

FDT Power/Comm: GOOD  
 Frame Attached: IBM Power7 775  
 MDA-FD RL: 45D  
 Error Status: WARNING  
 Tank Level: Full  
 Air Pump: Off  
 Water Pump: DISABLED  
 Tool Mode: Ready  
 Pressure Test Calibration: Incomplete  
 Component Pressure Test: Incomplete

Sample FDT Status

15. Review the FDT status screen and ensure the following status items are OK:

Status Item	State	Action
-------------	-------	--------

- **Tool Mode:** **Ready** – OK. Check next Status item.
- **Error Status:** **NONE** – OK. Check next Status item.

**WARNING** – *click* the **Decode Error Status** button, record the information returned and check Tank Level.

**CRITICAL** – *click* the **Decode Error Status** button, record the information returned and contact next level of support.

- **Tank Level:** **Full, Upper Half, or Lower Half** – OK.  
Note tank level, and proceed to next step.  
**Empty** – FDT cannot be drained.  
Exit procedure.

16. Locate an empty system water container.

Transport the container to the location of the FDT.

Do not place the container between the FDT and the open frame.

**NOTE:** Use an empty system water container **only**. If a non-empty system water container is used, water will overflow out of the container.

IBM PN **45D2124** (U.S.), **45D2129** (non-U.S.).

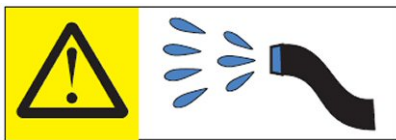
**CAUTION:** The water-based coolant solution may contain an additive intended to inhibit corrosion (or provide other functions). The solution may cause irritation to the skin or eyes. Avoid direct contact with the solution. Employ appropriate Personal Protective Equipment when performing operations involving the coolant or which may potentially expose you to the coolant. Refer to the MSDS for more information. (C037)



**CAUTION:** Protective eyewear is needed for the procedure. (L011)

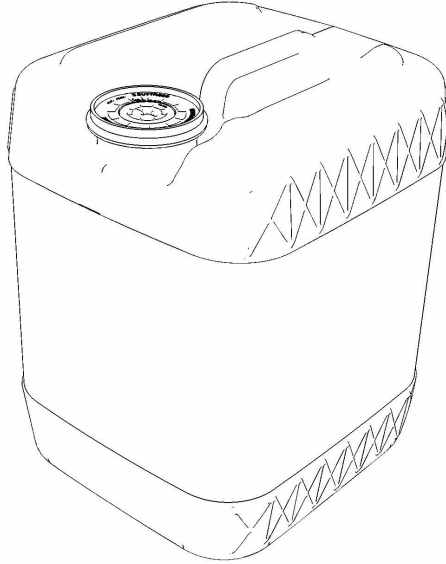


**CAUTION:** Chemical resistant gloves are needed for this procedure. (L014)

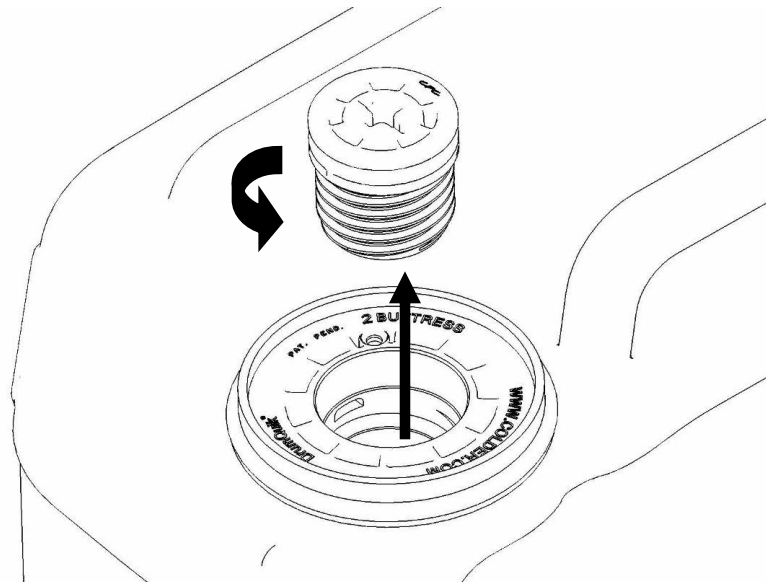


**DANGER:** Risk of electric shock due to water or a water solution which is present in this product. Avoid working on or near energized equipment with wet hands or when spilled water is present. (L016)

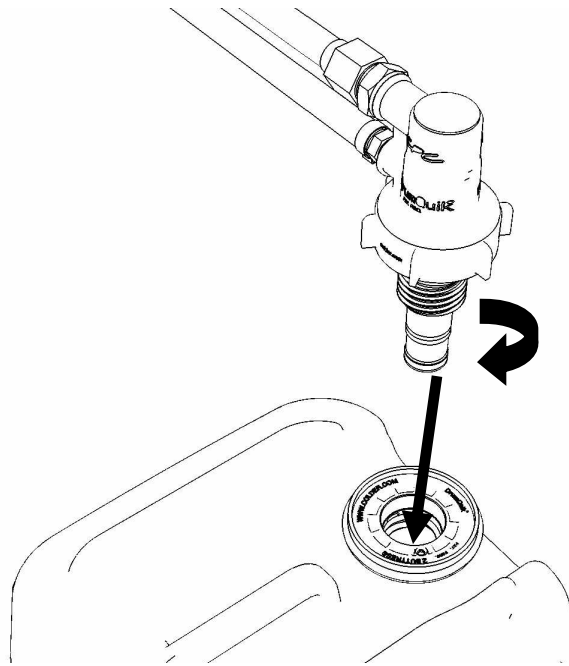
The system water is treated and must not be poured down a sink or on the ground.



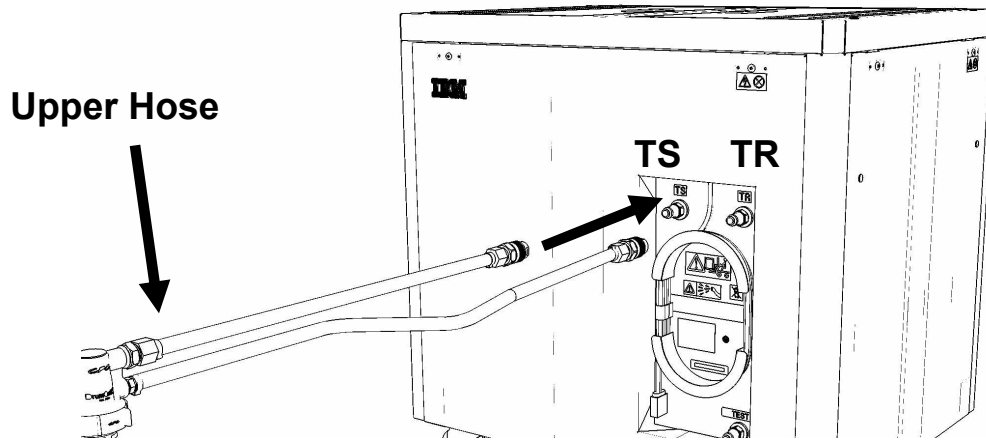
17. Remove the inner cap from the white system water container insert.  
Unthread inner cap counter-clockwise with a large screwdriver.



18. Remove transfer hose assembly **THA** from the upper tool storage compartment.  
19. Insert large white threaded insert of **THA** into the system water container.  
Turn clockwise until hand tight.



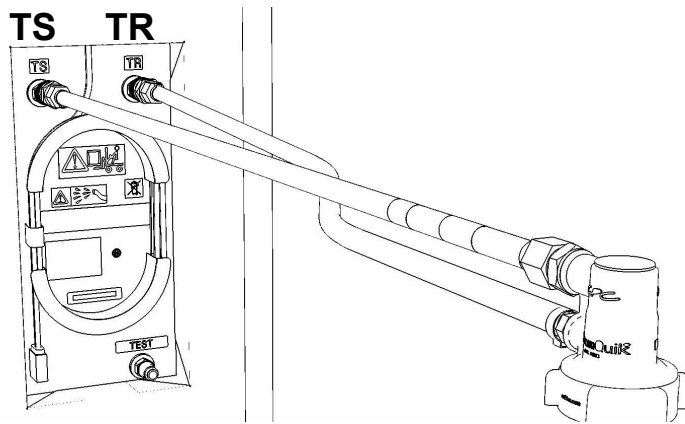
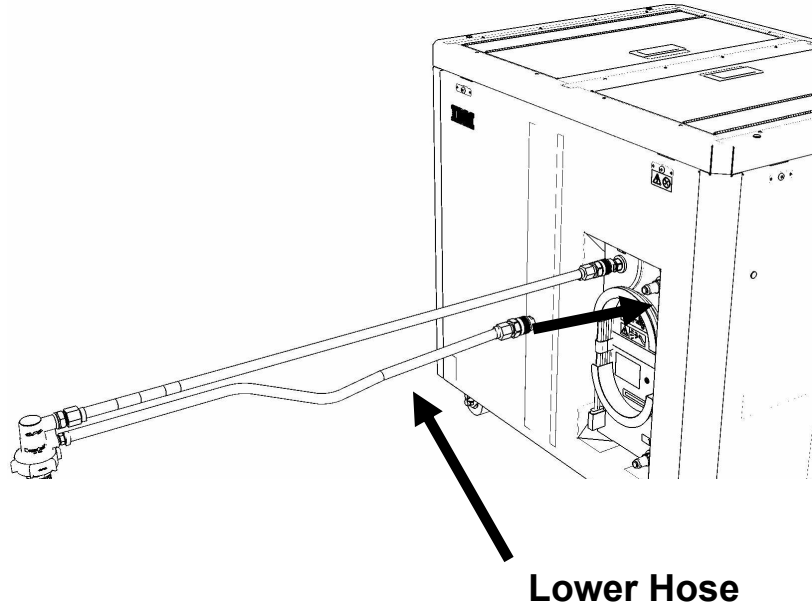
20. Connect the **Upper THA Hose** to the **TS** connection on the front panel of the FDT.



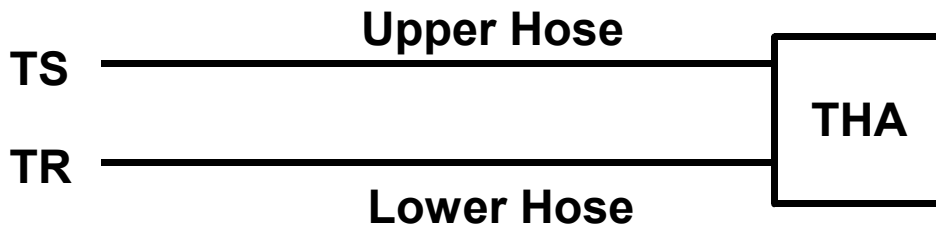
21. Connect the **Lower THA Hose** to the **TR** connection on the front panel of the FDT.



Power775 Bulk Power Enclosure (BPE) Service Procedure  
---- Appendix G: FDT Tank Drain Procedure ----



22. Ensure all water connections are made properly and securely.



23. On the FDT panel, *click* the **Drain FDT** button.

The **Get FDT Status** button may be *clicked* to examine FDT status.

**NOTE:** *The water pump will shut off after 1 minute, 40 seconds of run time.*

**CAUTION:** **This unit must not be left running unattended, service personnel should always be overseeing the process. (C038)**

24. Verify that the container feels full of water after FDT drain.

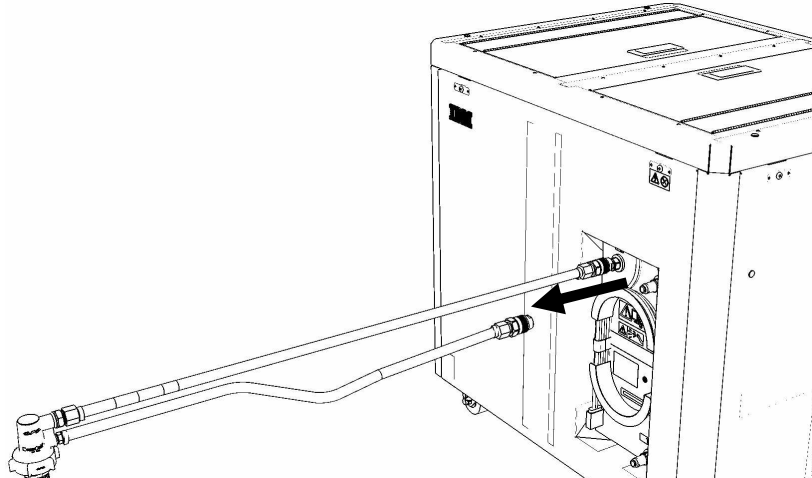
Container will weigh approximately 35 lbs. (16 kg) when full.

- If container feels full, proceed to **Step 25**.
- If container feels empty, repeat **Step 20** and continue with procedure.  
To prevent overflow, only repeat if the system water container is **still empty**.

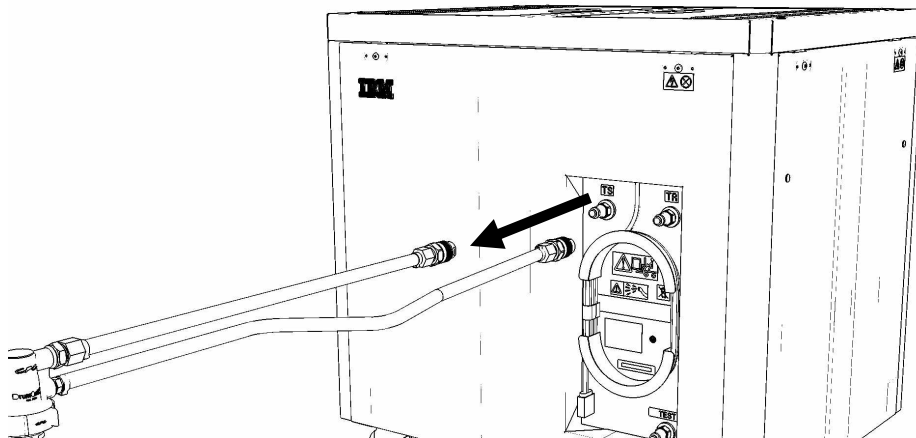
25. Click the Get FDT Status button and ensure the following status items are OK:

Status Item	State	Action
• <b>Tool mode:</b>	<b>Ready</b> – OK. Check next Status item. <b>FDT Drain Mode</b> – water pump still running. Wait 30 seconds and repeat <b>Step 25</b> .	
• <b>Error Status:</b>	<b>NONE</b> – OK. Check next Status item. <b>WARNING</b> – <i>click</i> the <b>Decode Error Status</b> button, record information returned and proceed to next step. <b>CRITICAL</b> – <i>click</i> the <b>Decode Error Status</b> button, record information returned and contact next level of support.	
• <b>Tank Level:</b>	Repeat <b>Step 16</b> to <b>Step 25</b> (with additional empty container) until desired level is reached. If tank level does not fall, repeat <b>Step 16</b> through <b>Step 25</b> . If tank level does not decrease after repeat, contact next level of support. To prevent overflow, only repeat if the system water container is <b>still empty</b> .	

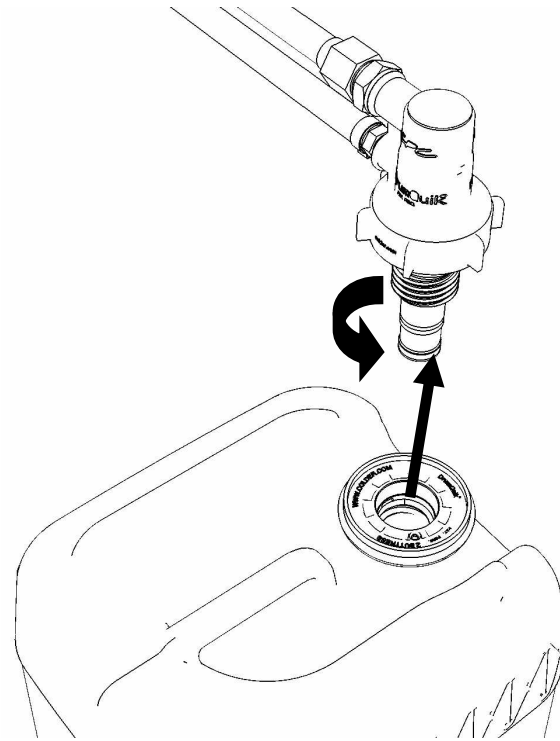
26. Disconnect the **Lower THA Hose** from the **TR** connection on the front panel of the FDT.



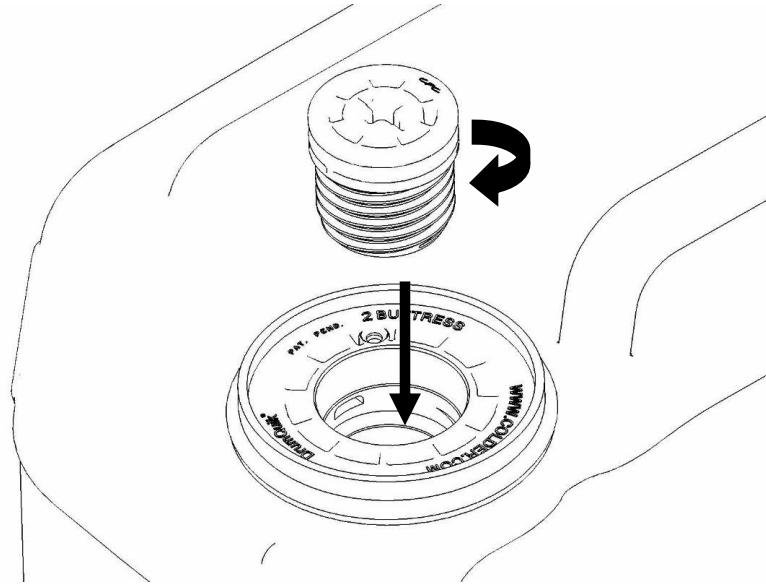
27. Disconnect the **Upper THA Hose** from the **TS** connection on the front panel of the FDT.



28. Remove large white threaded insert of **THA** from the system water container.  
Turn **slowly** counterclockwise until removed.  
Some residual pressure may remain on the system water container



29. Replace the inner cap into the white system water container insert.  
Turn inner cap clockwise with a large screwdriver.



30. Place all hose assemblies and adapters in their appropriate locations within the FDT storage enclosure.

31. Determine whether the FDT will be used for another procedure:

- If the FDT will be used for another procedure, leave tool activated and go to that procedure now; skip the remaining steps of this procedure.
- If the FDT requires no further use - proceed to the next step.

32. Click the **Deactivate FDT** button.

- If the **Deactivate FDT** command is successful – OK. Proceed to next step.
- If the **Deactivate FDT** command fails– action required.

Repeat **Deactivate FDT**. If the **Deactivate FDT** command fails again, contact next level of support.

33. Disconnect FDT UPIC power cable from port T10 of BPC used.

Wrap the UPIC cable in appropriate cable storage location on FDT.

34. If this procedure was referenced from another procedure, return to parent procedure.

---

## 10.4 End of Appendix G: Power775 Fill and Drain Tool (FDT) Tank Drain Procedure

# 11 APPENDIX H: IBM POWER775 FDT VOLUME TABLES

## 11.1 IBM Power 775 Component Water Volumes

	Liters	Gallons
WCU	10.75	2.84
Supply Manifold	5.64	1.49
Return Manifold	5.64	1.49
CEC	1.74	0.46
CEC DCCA	0.07	0.02
CEC + 2 DCCAs	1.87	0.49
BPE	0.97	0.26
BPR	0.12	0.03
BPD	0.18	0.05
Disk Enclosure	0.90	0.24
RDHX	7.50	1.98
System Water Container	15.00	3.96
FDT Tank (Internal Reservoir)	32.00	8.45

Table 5 IBM Power 775 Component Water Volumes

## 11.2 IBM Power 775 System Water Volumes

		Number of CEC Drawers										
		2	3	4	5	6	7	8	9	10	11	12
Number of Disk Enclosures	0	46.8	48.6	50.5	63.6	65.4	67.3	69.2	82.3	84.1	86.0	87.9
	1	47.7	49.5	51.4	64.5	66.3	68.2	70.1	83.2	85.0	86.9	88.8
	2	48.6	50.4	52.3	65.4	67.2	69.1	71.0	84.1	85.9		
	3	49.5	51.3	53.2	66.3	68.1	70.0	71.9				
	4	50.4	52.2	54.1	67.2	69.0						
	5	51.3	53.1	55.0								
	6	52.2										

(Volumes in Liters)

Table 6 IBM Power 775 System Water Volume (Liters)

		Number of CEC Drawers										
		2	3	4	5	6	7	8	9	10	11	12
Number of Disk Enclosures	0	12.4	12.8	13.3	16.8	17.3	17.8	18.3	21.7	22.2	22.7	23.2
	1	12.6	13.1	13.6	17.0	17.5	18.0	18.5	22.0	22.5	23.0	23.5
	2	12.8	13.3	13.8	17.3	17.8	18.3	18.8	22.2	22.7		
	3	13.1	13.6	14.1	17.5	18.0	18.5	19.0				
	4	13.3	13.8	14.3	17.7	18.2						
	5	13.5	14.0	14.5								
	6	13.8										

(Volumes in Gallons)

Table 7 IBM Power 775 System Water Volume (Gallons)

### 11.3 IBM Power 775 System Water Containers per Frame

		Number of CEC Drawers										
		2	3	4	5	6	7	8	9	10	11	12
Number of Disk Enclosures	0	4	4	4	5	5	5	5	6	6	6	6
	1	4	4	4	5	5	5	5	6	6	6	6
	2	4	4	4	5	5	5	5	6	6		
	3	4	4	4	5	5	5	5				
	4	4	4	4	5	5						
	5	4	4	4								
	6	4										

Table 8 IBM Power 775 Required Number of System Water Containers per Frame

### 11.4 End of Appendix H: IBM Power775 FDT Volume Tables

---

## 12 APPENDIX I: POWER775 BULK POWER ENCLOSURE (BPE) PRESSURE TEST PROCEDURE WITHOUT COMPONENTS

---

### 12.1 Safety Notices

Read “Safety Notices“ available from InfoCenter:

<http://publib.boulder.ibm.com/infocenter/powersys/v3r1m5/topic/p7hdx/G229-9054.pdf>

The following cautions apply to all Power775 service procedures:

**CAUTION:**

**Energy hazard present and Shorting might result in system outage and possible physical injury. Remove all metallic jewelry before servicing. (C001)**

**CAUTION:**

**The doors and covers to the product are to be closed at all times except for service by trained service personnel. All covers must be replaced and doors locked at the conclusion of the service operation. (C013)**

**CAUTION:**

**Service of this product or unit is to be performed by trained service personnel only. (C032)**

The following notices specifically pertain to this Power775 service procedure.

**CAUTION: The water-based coolant solution may contain an additive intended to inhibit corrosion (or provide other functions). The solution may cause irritation to the skin or eyes. Avoid direct contact with the solution. Employ appropriate Personal Protective Equipment when performing operations involving the coolant or which may potentially expose you to the coolant. Refer to the MSDS for more information. (C037)**

**CAUTION: This unit must not be left running unattended, service personnel should always be overseeing the process. (C038)**



**DANGER: Hazardous voltage present. Voltages present constitute a shock hazard, which can cause severe injury or death. (L004)**



**CAUTION: Protective eyewear is needed for the procedure. (L011)**

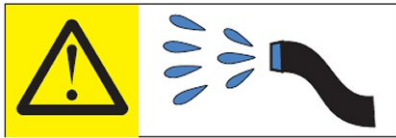




**DANGER:** Heavy equipment—personal injury or equipment damage might result if mishandled. (L013)



**CAUTION:** Chemical resistant gloves are needed for this procedure. (L014)



**DANGER:** Risk of electric shock due to water or a water solution which is present in this product. Avoid working on or near energized equipment with wet hands or when spilled water is present. (L016)

## 12.2 Background:

This document contains the procedure for performing an air pressure test on a Bulk Power Enclosure (BPE) on an **IBM Power 775** system, using an **IBM Power 775** Fill and Drain Tool (FDT). This procedure is to be used on a BPE that does not have any BPE components installed or a BPE what has all the components disconnected from the BPE water connections.

The successful execution of a **FDT Pressure Test Calibration** procedure is required for this procedure to be performed.

**NOTE:** *If performing a pressure test on a BPE that is populated with the BPE components and is in the frame refer to Appendix B for the populated BPE pressure test procedure. This procedure only tests the BPE without any components connected to the BPE..*

To ensure that all **IBM Power 775** water-cooled BPE's are leak-free, the **IBM Power 775** Fill and Drain Tool (FDT) is equipped with pressure testing capability. The BPE pressure test is designed to identify leaks in the BPE internal plumbing and must be completed before a BPE can be installed in the frame, components added and a fill procedure is executed so that any potential for water leakage in the system can be avoided.

The results of the BPE pressure test are recorded within the FDT; if the test passes, the BPE can be installed in the frame, populated with the components already known good and a BPE fill procedure can be completed. If this test fails, there is a functional defect in the BPE, and the BPE fill cannot be completed. Upon a pressure test failure of the BPE, the next level of support must be contacted to replace the hardware.

A BPE fill procedure should not be executed unless both the **FDT Pressure Test Calibration** and **BPE Pressure Test** have passed since FDT activation.

The pressure test must be completed on an empty BPE. A new BPE should ship without water to the customer location, and no additional drainage is required. If the FDT senses that the BPE is not empty when the pressure test begins, the pressure test will stop. The pressure test status will be set as incomplete, and a BPE drain operation will be required.

### **Reference Information:**

<b>IBM Power 775</b> FDT P/N:	<b>45D6928</b>
Hose assemblies/adapters required:	<b>HA1</b> (45D8561) <b>HA2</b> (45D8562)

Expected maximum time to complete BPE pressure test: 8 min

**NOTE:** *Some steps in this procedure may be redundant due to other service operations being completed prior to this procedure. If a step has already been completed, verify that the step has been completed properly and proceed to the next step.*

**NOTE:** *The location of the component for the pressure test procedure is not important. The pressure test can be completed with the component on a cart, on the lift tool, or mechanically installed in the frame.*

---

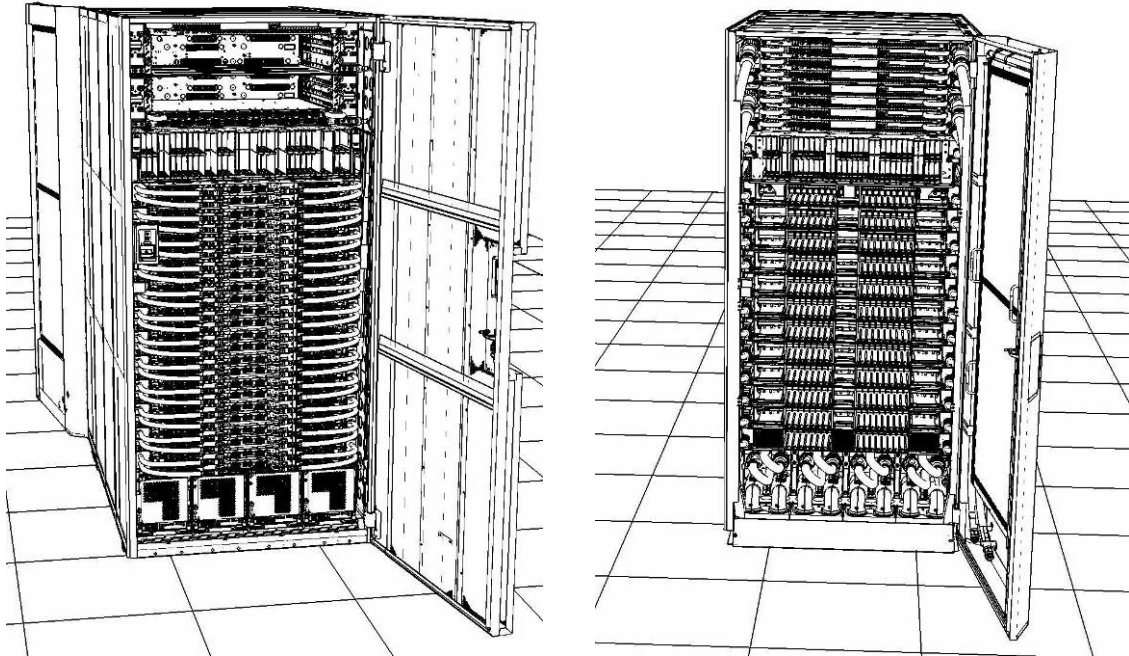
### **12.3 Procedure:**

**NOTE:** If you already have the FDT powered on, proceed to **Step 14**. Otherwise, start procedure at **Step 1**.

1. Identify the **Power 775** frame that requires service.

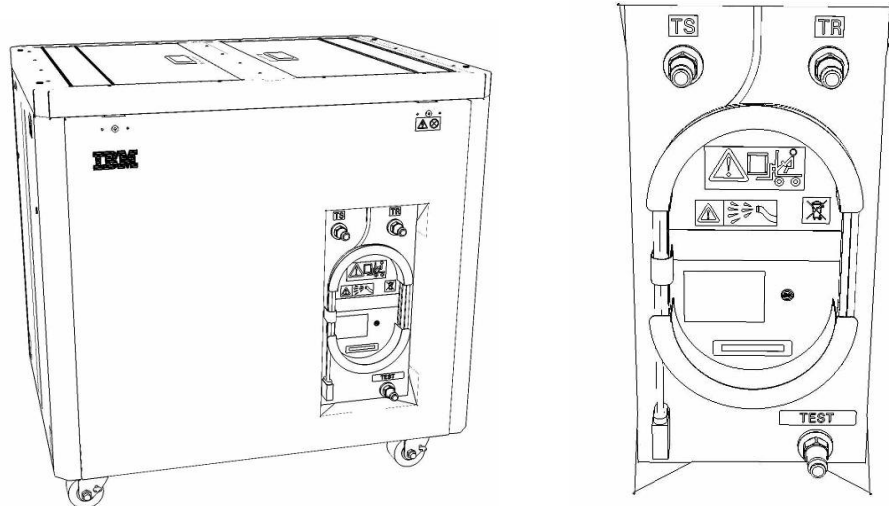
Verify that the system UEPO is set to **ON**, and the managing consoles (HMC and XCat) are powered on and communicating with the frame.

2. Open front and rear doors of the **Power 775** frame that requires service.

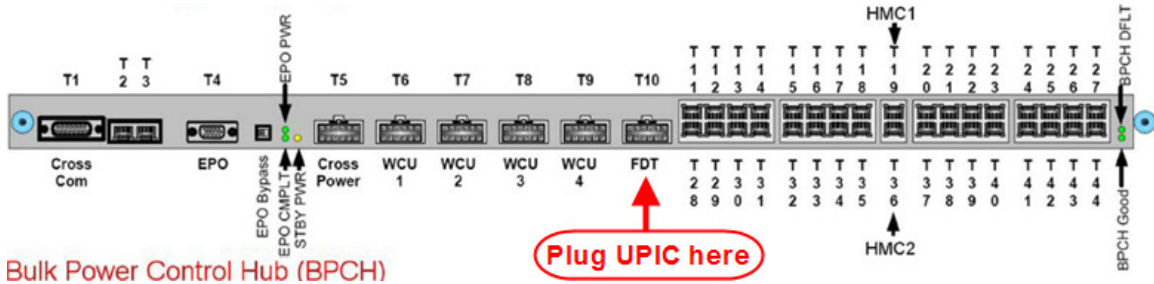


3. Bring the FDT to the front side of the **Power 775** frame that requires service.
4. Locate the panel of the FDT that contains the Universal Power and Information Cable (UPIC), as well as the **TS**, **TR**, and **TEST** water connections.

This side of the tool should be facing the front of the frame.

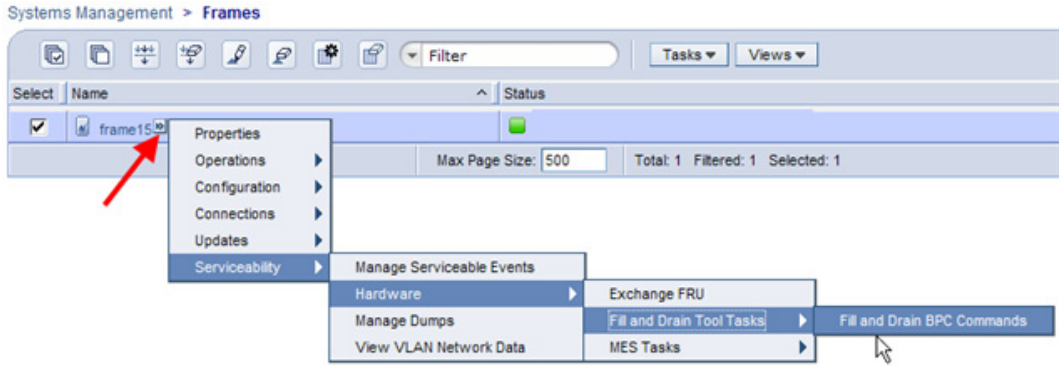


5. Unwrap the FDT UPIC cable from the storage loop on the FDT.
6. Select BPC port for FDT
  - If the lower BPA is not targeted for service, and is functional:  
Plug the FDT UPIC cable into **port T10 of the lower BPC**.
  - If the lower BPA is targeted for service, or is not functional:  
Plug the FDT UPIC cable into **port T10 of the upper BPC**.



7. Login to the HMC with the User ID `hscroot`.  
Use the HMC that is connected to the BPA where the FDT is plugged.
8. From the HMC left Navigation menu, expand **Systems Management** then select **Frames**.  
Verify frame serial number for the frame to be serviced.
9. In the **Frames** view on the HMC, place a checkmark in the **Select** column for the frame to be serviced.
10. Verify that the frame **Status** is **Rack Standby/Rack Standby** or **Standby/Standby**.
  - If frame **Status** reads **Standby/Rack Standby** or **Standby/Standby** – OK.  
Continue to next step.
  - If frame **Status** does not read **Rack Standby/Rack Standby** or **Standby/Standby** – action required. Contact next level of support.
11. From the **Task** menu on the HMC, *select* **Serviceability** > **Hardware** > **Fill and Drain Tool Tasks** > **Fill and Drain Command Interface**

Power775 Bulk Power Enclosure (BPE) Service Procedure  
 ---- Appendix B: BPE Pressure Test Procedure ----



**Fill and Drain Tool Command Interface** will display. See below for a sample image of the interface (FDT deactivated).

**Fill and Drain Tool (FDT) Command Interface - Server-78AC-100BC50029**

The table below shows the FDT Port locations that can communicate with the Fill and Drain Tool. Select the port to which the Fill and Drain Tool is connected. Use the buttons to drive commands to the Fill and Drain Tool connected to a port.

FDT Port Locations:

Select	Location Code	Description
<input type="radio"/>	78AC-100*BC50029-P7-C1	Lower BPC Port T10
<input type="radio"/>	78AC-100*BC50029-P8-C1	Upper BPC Port T10

12. Select the BPC port that the FDT was plugged into in **Step 6** from the **FDT Port Locations:** list.

13. *Click* the **Activate FDT** button.

- If the Activate FDT command is successful – OK. **Wait 30 seconds and continue to next step.**
- If the **Activate FDT** command fails – action required.

*Click* the **Deactivate FDT** button.

Wait 2 minutes and repeat **Step 13**. If the **Activate** command fails again, contact next level of support.

14. *Click* the **Get FDT Status** button.

- If the **Get FDT Status** command is successful – OK.

See below for a sample status (does not reflect expected state)

- If the **Get FDT Status** command fails – action required.

Repeat **Step 14**. If the **Get FDT Status** command fails again, contact next level of support.

**Fill and Drain Tool (FDT) Command Interface - Server-78AC-100BC50029**

The table below shows the FDT Port locations that can communicate with the Fill and Drain Tool. Select the port to which the Fill and Drain Tool is connected. Use the buttons to drive commands to the Fill and Drain Tool connected to a port.

FDT Port Locations:

Select	Location Code	Description
<input checked="" type="radio"/>	78AC-100*BC50029-P7-C1	Lower BPC Port T10
<input type="radio"/>	78AC-100*BC50029-P8-C1	Upper BPC Port T10

FDT Power/Comm: GOOD  
 Frame Attached: IBM Power7 775  
 MDA-FD RL: 45D  
 Error Status: WARNING  
 Tank Level: Full  
 Air Pump: Off  
 Water Pump: DISABLED  
 Tool Mode: Ready  
 Pressure Test Calibration: Incomplete  
 Component Pressure Test: Incomplete

Sample FDT Status

15. Review the FDT status screen and ensure that the following status items are OK:

Status Item	State	Action
• <b>Tool Mode:</b>	<b>Ready</b>	– OK. Check next Status item.
• <b>Error Status:</b>	<b>NONE</b>	– OK. Check next Status item.
	<b>WARNING</b>	– <i>click</i> the <b>Decode Error Status</b> button, record the information returned and check Tank Level.
	<b>CRITICAL</b>	– <i>click</i> the <b>Decode Error Status</b> button, record the information returned and contact next level of support.
• <b>Tank Level:</b>	<b>Upper Half, Lower Half or Empty</b>	– OK. Check next Status item.



**Full** – action required.

Exit this procedure and complete a **Fill and Drain Tool (FDT) Tank Drain Procedure**.

Once FDT tank level is **Upper Half, Lower Half** or **Empty**, return to this step and continue with procedure.

- **Pressure Test Calibration:** **Pass** - OK. Check next Status item.  
**Incomplete** or **Fail** – action required.  
Exit this procedure and complete the **Pressure Test Calibration** procedure.  
Once a **passing** result is confirmed, return to this step and continue with procedure.
- **Component Pressure Test:** **Incomplete** – OK. Continue to next step.  
**Pass** or **Fail** – action required.  
*Click* the **Reset FDT** button and proceed to next step.

16. Verify all BPR and BPD hoses (if present) **are not plugged** into the BPE.

17. Verify that BPE water connections **are not** connected to system manifolds.

BPE should be drained of water.

18. Before proceeding, read required safety information:

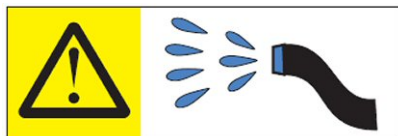
**CAUTION:** The water-based coolant solution may contain an additive intended to inhibit corrosion (or provide other functions). The solution may cause irritation to the skin or eyes. Avoid direct contact with the solution. Employ appropriate Personal Protective Equipment when performing operations involving the coolant or which may potentially expose you to the coolant. Refer to the MSDS for more information. (C037)



**CAUTION:** Protective eyewear is needed for the procedure. (L011)



**CAUTION:** Chemical resistant gloves are needed for this procedure. (L014)



**DANGER:** Risk of electric shock due to water or a water solution which is present in this product. Avoid working on or near energized equipment with wet hands or when spilled water is present. (L016)

19. Verify BPE position for pressure test.

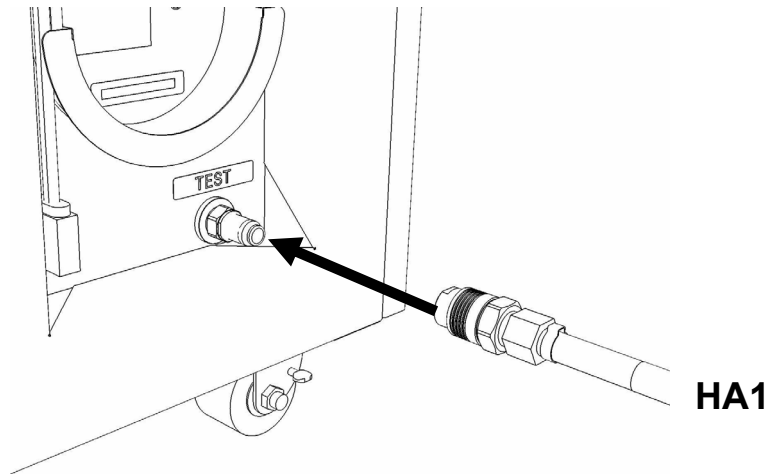
- If the BPE is not installed in the system – continue to next step.
- If the BPE is installed in the system – action required.

Pass the unattached ends of **HA1** and **HA2** to the rear of the frame.

**NOTE:** Hose assemblies **HA1** and **HA2** can be passed **around** the frame or **over** the frame, depending on frame position. These hoses are long enough to complete all FDT service actions on the rear of the frame.

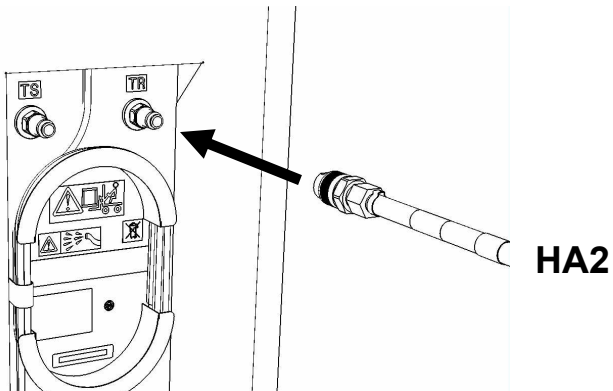
20. Remove hose assembly **HA1** from the upper tool storage compartment.

Connect either end of hose assembly **HA1** to the **TEST** connection on the front panel of the FDT.



21. Remove hose assembly **HA2** from the upper tool storage compartment.

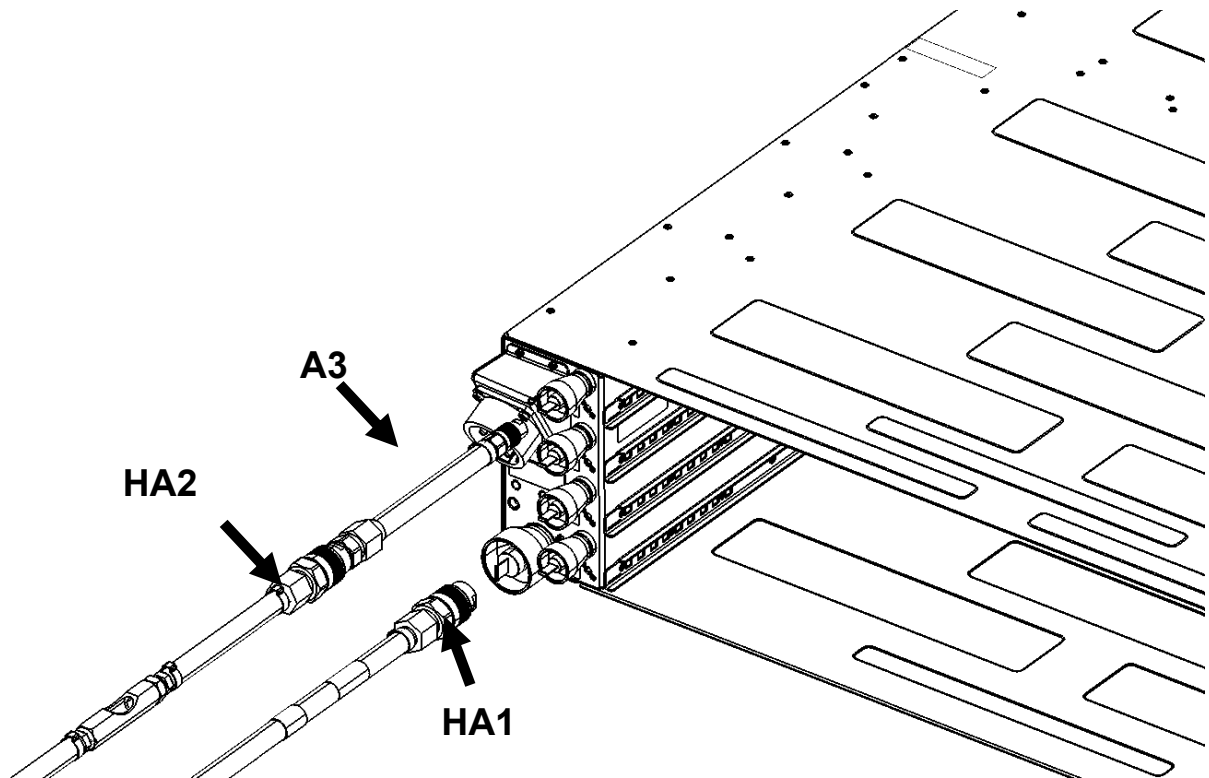
Connect the end *without sight glass* to the **TR** connection on the FDT.



22. Connect the unattached end of hose assembly **HA1** to the left side BPE water connection.

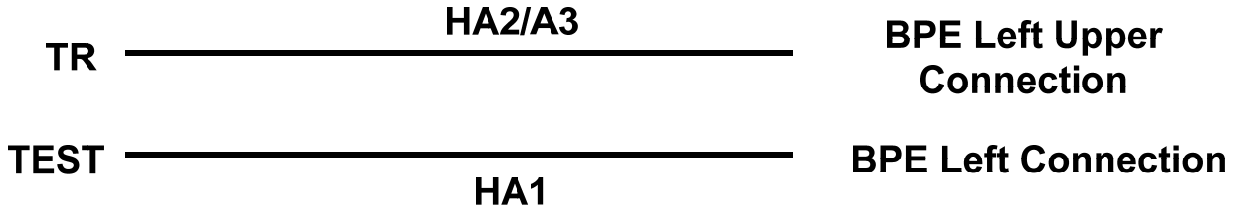
23. Connect the unattached end of hose assembly HA2 to adapter A3.

24. Connect the unattached end of adapter A3 to the left upper BPR water connection.



25. Ensure all hose connections are made properly and securely.

Verify hoses are connected as outlined in the schematic below.



26. On the FDT Panel, *click* the **Component Pressure Test** button.

The **Get FDT Status** button may be *clicked* to examine FDT status.

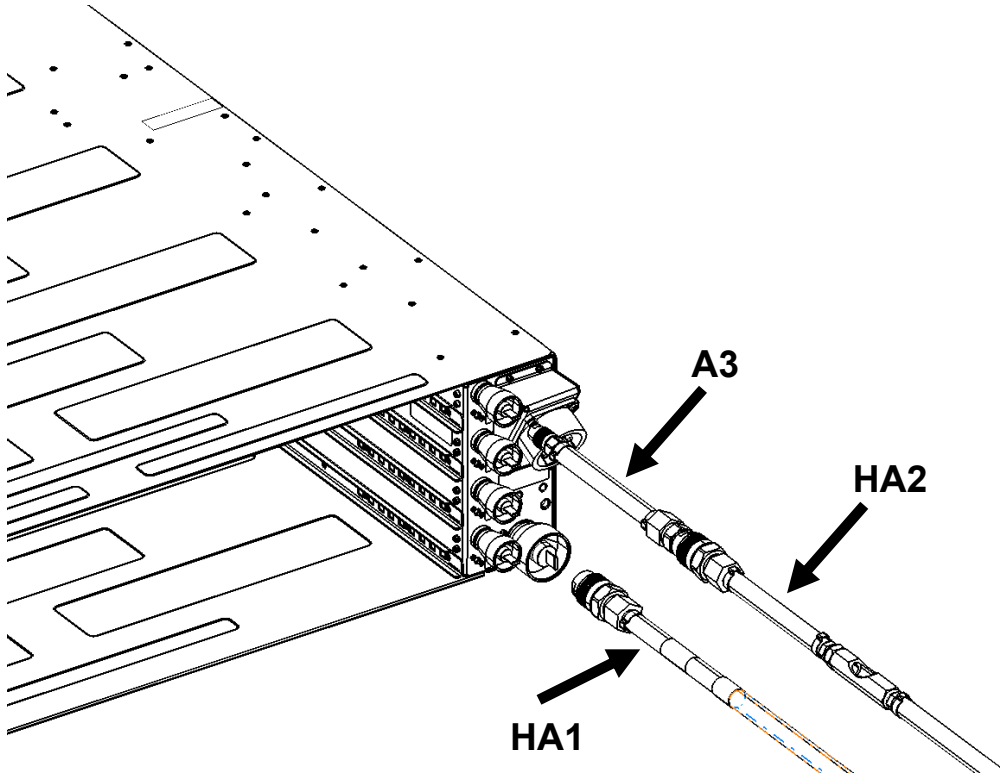
**NOTE:** *The pressure testing will last for 4 minutes (2 minutes with air pump on)*

**CAUTION:** *This unit must not be left running unattended, service personnel should always be overseeing the process. (C038)*

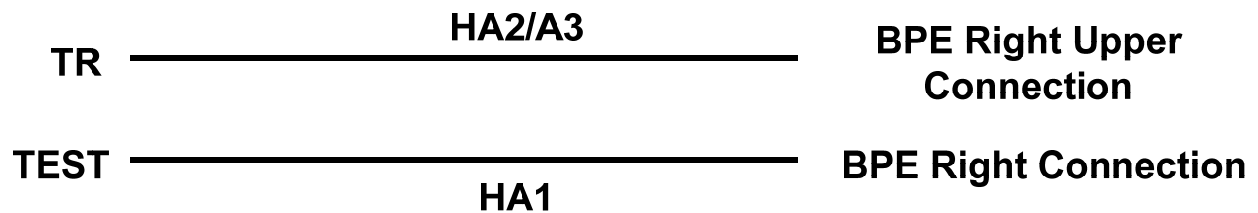
27. Click Get Status and ensure that the following status items are OK:

Status Item	State	Action
• <b>Tool mode:</b>	<b>Ready</b> – OK.	Check next Status item.
	<b>System/Component Pressure Test Mode</b> – pressure test still running.	Wait 30 seconds and repeat <b>Step 26</b> .
• <b>Error Status:</b>	<b>NONE</b> – OK.	Check next Status item.
	<b>WARNING</b> – <i>click</i> the <b>Decode Error Status</b> button, record information returned and proceed to next step.	
	<b>CRITICAL</b> – <i>click</i> the <b>Decode Error Status</b> button, record information returned and contact next level of support.	
• <b>Component Pressure Test:</b>	<b>Pass</b> – OK.	Proceed to next step.
	<b>Fail or Incomplete</b> – action required.	<i>Click</i> the <b>Reset FDT</b> button.
		Repeat <b>Step 20</b> through <b>Step 24</b> and continue with procedure.
		If the test reads <b>Fail</b> twice, hardware is defective. Contact next level of support.

28. The component pressure test has passed successfully on the left side of the BPE, proceed to the next step.
29. Remove the end of hose assembly **HA1** from the left side BPE water connection and connect it to the right side water connection.
30. Remove the end of adapter **A3** attached to the left upper BPR water connection and connect it to the right upper BPR water connection.



31. Ensure all hose connections are made properly and securely.  
 Verify hoses are connected as outlined in the schematic below.



32. On the FDT Panel, *click* the **Component Pressure Test** button.  
 The **Get FDT Status** button may be *clicked* to examine FDT status.  
**NOTE:** *The pressure testing will last for 4 minutes (2 minutes with air pump on)*

**CAUTION: This unit must not be left running unattended, service personnel should always be overseeing the process. (C038)**

33. Click Get Status and ensure that the following status items are OK:

Status Item	State	Action
• <b>Tool mode:</b>	<b>Ready</b> – OK. Check next Status item. <b>System/Component Pressure Test Mode</b> – pressure test still running. Wait 30 seconds and repeat <b>Step 26</b> .	
• <b>Error Status:</b>	<b>NONE</b> – OK. Check next Status item. <b>WARNING</b> – <i>click</i> the <b>Decode Error Status</b> button, record information returned and proceed to next step. <b>CRITICAL</b> – <i>click</i> the <b>Decode Error Status</b> button, record information returned and contact next level of support.	
• <b>Component Pressure Test:</b>	<b>Pass</b> – OK. Proceed to next step. <b>Fail or Incomplete</b> – action required. <i>Click</i> the <b>Reset FDT</b> button. Repeat <b>Step 20</b> through <b>Step 24</b> and continue with procedure. If the test reads <b>Fail</b> twice, hardware is defective. Contact next level of support.	

34. The component pressure test has passed successfully on the right side of the BPE, pressure test is complete. Proceed to the next step.

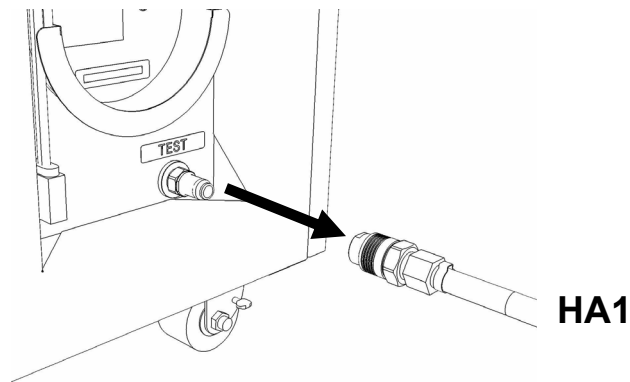
35. If required, a BPE fill procedure can now be completed.

**NOTE:** If a BPE Fill Procedure will be completed following this test, disregard Step 36, 37, 38, 39 and 40. Remove adapter A3 from HA2 as this won't be used in the fill procedure and place in the FDT storage compartment.

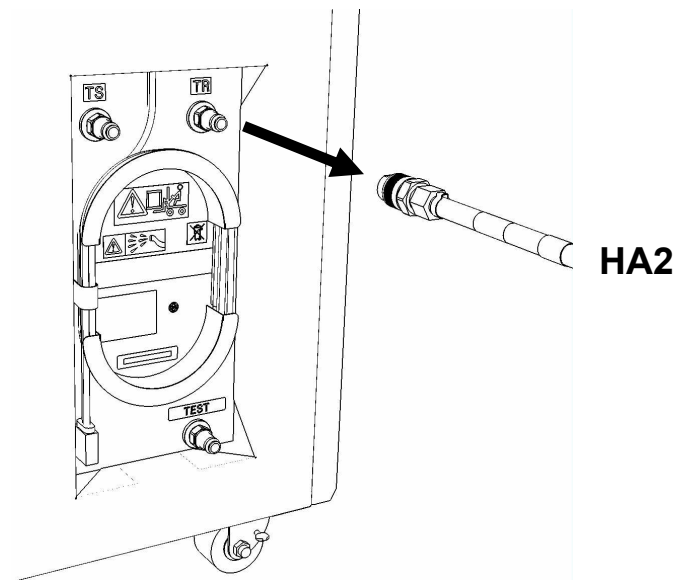
36. Disconnect the HA1 hose assembly from the right side BPE water connection.

37. Disconnect the HA2/A3 hose assembly and adapter from the right side BPE water connection.

38. Disconnect the FDT end of HA1 from TEST on the FDT.



39. Disconnect the FDT end of HA2 from TR on the FDT.



40. Place all hose assemblies and adapters in their appropriate locations within the FDT storage enclosure.

41. Determine whether the FDT will be used for another procedure:

- If the FDT will be used for another procedure, leave tool activated and go to that procedure now; skip the remaining steps of this procedure.
- If the FDT requires no further use - proceed to the next step.

42. Click the **Deactivate FDT** button.

- If the **Deactivate FDT** command is successful – OK. Proceed to next step.
- If the **Deactivate FDT** command fails– action required.

Repeat **Deactivate FDT**. If the **Deactivate FDT** command fails again, contact next level of support.

43. Disconnect FDT UPIC power cable from port T10 of BPC used.

Wrap the UPIC cable in appropriate cable storage location on FDT.

44. If this procedure was referenced from another procedure, return to parent procedure.

---

## **12.4 End of Appendix I: Power775 Bulk Power Enclosure (BPE) Pressure Test Procedure without components**