

WebSphere CloudBurst Appliance
Second Edition

*Hardware Problem Determination and
Service Guide*

IBM

WebSphere® CloudBurst Appliance
Second Edition

*Hardware Problem Determination and
Service Guide*

IBM

Note

Before using this information and the product it supports, read the information in "Safety" on page v and, if necessary, the language-specific information for your locale in *IBM Systems Safety Notices*, G229-9054-01.

Before using this information and the product it supports, read the information in "Notices" on page 41.

Second Edition (October 2010)

This edition applies to IBM WebSphere CloudBurst Appliance until otherwise indicated in new editions.

© Copyright IBM Corporation 2009, 2010.

US Government Users Restricted Rights – Use, duplication or disclosure restricted by GSA ADP Schedule Contract with IBM Corp.

Contents

Safety	v
Guidelines for servicing electrical equipment	vi
Inspecting for unsafe conditions	vii
Safety statements	viii
Danger notices	ix
Caution notices	x
Labels	xiv

Preface	xv
Who should read this document	xv
How this document is organized	xv
Related documents	xv
The Documentation CD	xvi
Hardware and software requirements	xvi
Using the Documentation CD	xvi
Available documents	xvii
Warranty information	xvii
Notices and conventions	xvii
Typeface conventions	xviii

Chapter 1. Introduction	1
Specifications and features	1
Specifications	1
Features	2
Components	2
Front view	2
Rear view	4

Chapter 2. Diagnostics	7
LED lights	7
Front panel	7
Rear panel	8
Testing the hardware from the command line	10
Viewing status providers for sensors	11

Chapter 3. Troubleshooting	13
Troubleshooting workflow	13
Troubleshooting CRU parts	14
Troubleshooting fan modules	15
Troubleshooting the power supply module	15
Troubleshooting the hard disk drive module	15
Troubleshooting individual disks	16
Troubleshooting consumable parts	16
Troubleshooting the battery	16
Troubleshooting the appliance	17

Chapter 4. Removing or replacing parts or the appliance.	19
Installation guidelines	19

Handling static-sensitive devices	20
Returning a appliance or component	20
Parts listing	20
Rear parts listing	20
Consumable parts listing	22
Power cords	22
Model type	23
Turning off the appliance	23
Removing and replacing CRU parts	23
Replacing a fan module	23
Replacing a power supply module	25
Replacing the hard disk drive module	26
Replacing individual disks	28
Removing and replacing consumable parts	30
Replacing the battery	30
Removing and replacing the appliance from the rack	33
Removing the RJ-45 cable	33
Removing the appliance from the rack	33
Replacing the appliance in the rack	35
Applying the repair identification tag	35

Appendix. Getting help and technical assistance	37
Searching knowledge bases	37
Receiving automatic updates	37
Receiving updates through My support	37
Receiving updates through RSS feeds	38
Getting a fix	38
Contacting IBM Support	39

Notices	41
Important notes	41
Electronic emission notices	41
Federal Communications Commission (FCC) statement	41
Industry Canada Compliance Statement	42
Avis de conformité à la réglementation d'Industrie Canada	42
United Kingdom telecommunications safety requirement	42
European Union EMC Directive conformance statement	42
Japanese Voluntary Control Council for Interference (VCCI) statement	43
Taiwanese Class A warning statement	43
Chinese Class A warning statement	43
Korean Class A warning statement	43
Russian Class A warning statement	44
Trademarks	44

Safety

Before installing this product, read the Safety Information.

Arabic

قبل تركيب هذا المنتج، يجب قراءة الملاحظات الأمنية

Brazilian Portuguese

Antes de instalar este produto, leia as Informações de Segurança.

Chinese (simplified)

在安装本产品之前，请仔细阅读 **Safety Information** (安全信息)。

Chinese (traditional)

安裝本產品之前，請先閱讀「安全資訊」。

Croatian

Prije instalacije ovog produkta obavezno pročitajte Sigurnosne Upute.

Czech

Před instalací tohoto produktu si přečtěte příručku bezpečnostních instrukcí.

Danish

Læs sikkerhedsforskrifterne, før du installerer dette produkt.

Dutch

Lees voordat u dit product installeert eerst de veiligheidsvoorschriften.

Finnish

Ennen kuin asennat tämän tuotten, lue turvaohjeet kohdasta Safety Information.

French

Avant d'installer ce produit, lisez les consignes de sécurité.

German

Vor der Installation dieses Produkts die Sicherheitshinweise lesen.

Greek

Πριν εγκαταστήσετε το προϊόν αυτό, διαβάστε τις πληροφορίες ασφάλειας (safety information).

Hebrew

לפני שתתקינו מוצר זה, קראו את הוראות הבטיחות.

Hungarian

A termék telepítése előtt olvassa el a Biztonsági előírásokat!

Italian

Prima di installare questo prodotto, leggere le Informazioni sulla Sicurezza.

Japanese

製品の設置の前に、安全情報をお読みください。

Korean

본 제품을 설치하기 전에 안전 정보를 읽으십시오.

Macedonian

Пред да се инсталира овој продукт, прочитајте информацијата за безбедност.

Norwegian

Les sikkerhetsinformasjonen (Safety Information) før du installerer dette produktet.

Polish

Przed zainstalowaniem tego produktu, należy zapoznać się z książką "Informacje dotyczące bezpieczeństwa" (Safety Information).

Portuguese

Antes de instalar este produto, leia as Informações sobre Segurança.

Russian

Перед установкой продукта прочтите инструкции по технике безопасности.

Slovak

Pred inštaláciou tohto zariadenia si pečítajte Bezpečnostné predpisy.

Slovenian

Pred namestitvijo tega proizvoda preberite Varnostne informacije.

Spanish

Antes de instalar este producto, lea la información seguridad.

Swedish

Läs säkerhetsinformationen innan du installerar den här produkten.

Guidelines for servicing electrical equipment

Observe the following guidelines when servicing electrical equipment:

- Check the area for electrical hazards such as moist floors, non-grounded power extension cords, and missing safety grounds.
- Use only approved tools and test equipment. Some hand tools have handles that are covered with a soft material that do not provide insulation from live electrical current.
- Regularly inspect and maintain your electrical hand tools for safe operational condition. Do not use worn or broken tools or testers.
- Ensure that the reflective surface of a dental mirror cannot contact a live electrical circuit. The surface is conductive and can cause personal injury or equipment damage if it comes in contact with a live electrical circuit.
- Some rubber floor mats contain small conductive fibers to decrease electrostatic discharge. Do not use this type of mat to protect yourself from electrical shock.
- Do not work alone under hazardous conditions or near equipment that has hazardous voltages.
- Locate the emergency power-off (EPO) switch, disconnecting switch, or electrical outlet. Ensure that you can quickly turn off the power in the event of an electrical accident.
- Disconnect all power before you perform a mechanical inspection, work near power supplies, or remove or install main units.
- Before working on the equipment, disconnect the power cord. If you cannot disconnect the power cord, power-off the wall box that supplies power to the equipment and lock the wall box in the off position.
- Never assume that power has been disconnected from a circuit. Check it to make sure that it has been disconnected.
- If you have to work on equipment that has exposed electrical circuits, observe the following precautions:

- Make sure that another person who is familiar with the power-off controls is near you and is available to turn off the power if necessary.
- When you are working with powered-on electrical equipment, use only one hand. Keep the other hand in your pocket or behind your back to avoid creating a complete circuit that could cause an electrical shock.
- When using a tester, set the controls correctly and use the approved probe leads and accessories for that tester.
- Stand on a suitable rubber mat to insulate you from grounds such as metal floor strips and equipment frames.
- Use extreme care when measuring high voltages.
- Do not service components (such as power supplies, pumps, blowers, fans, and motor generators) outside of their normal operating locations. This precaution helps to ensure proper grounding of components.
- If an electrical accident occurs, use caution, turn off the power, and send another person to get medical aid.

Inspecting for unsafe conditions

Use this information to help you identify potential unsafe conditions in an IBM® product that you are working on.

Each IBM product, as it was designed and manufactured, has required safety items to protect users and service technicians from injury. The information in this section addresses only those items. Use good judgment to identify potential unsafe conditions that might be caused by attachment of non-IBM features or options that are not addressed in this section. If you identify an unsafe condition, determine the seriousness of the hazard. Determine whether you must correct the problem before you work on the product.

Consider the following conditions and the safety hazards that they present:

- Electrical hazards, especially primary power. Primary voltage on the frame can cause serious or fatal electrical shock.
- Explosive hazards, such as a damaged CRT face or a bulging capacitor.
- Mechanical hazards, such as loose or missing hardware.

To inspect the product for potential unsafe conditions, complete the following steps:

1. Make sure that the power is off and the power cords are disconnected.
2. Make sure that the exterior cover is not damaged or broken, and observe any sharp edges.
3. Check the power cords:
 - Make sure that the third-wire ground connector is in good condition. Use a meter to measure third-wire ground continuity for 0.1 ohm or less between the external ground pin and the frame ground.
 - Make sure that the power cords are the correct type.
 - Make sure that the insulation is not frayed or worn.
4. Check for pinched cables.

Safety statements

The statements in this section are the statements that apply to the WebSphere® CloudBurst appliance. These statements are the exact same safety information that the *IBM Systems Safety Notices* document provides. However, the *IBM Systems Safety Notices* document provides the complete list of the safety notices for IBM Systems.

You can access the *IBM Systems Safety Notices* document on the *IBM WebSphere CloudBurst Appliance: Documentation CD*.

Danger notices

DANGER

When working on or around the system, observe the following precautions:

Electrical voltage and current from power, telephone, and communication cables are hazardous. To avoid a shock hazard:

- Connect power to this unit only with the IBM provided power cord. Do not use the IBM provided power cord for any other product.
- Do not open or service any power supply assembly.
- Do not connect or disconnect any cables or perform installation, maintenance, or reconfiguration of this product during an electrical storm.
- The product might be equipped with multiple power cords. To remove all hazardous voltages, disconnect all power cords.
- Connect all power cords to a properly wired and grounded electrical outlet. Ensure that the outlet supplies proper voltage and phase rotation according to the system rating plate.
- Connect any equipment that will be attached to this product to properly wired outlets.
- When possible, use one hand only to connect or disconnect signal cables.
- Never turn on any equipment when there is evidence of fire, water, or structural damage.
- Disconnect the attached power cords, telecommunications systems, networks, and modems before you open the device covers, unless instructed otherwise in the installation and configuration procedures.
- Connect and disconnect cables as described in the following procedures when installing, moving, or opening covers on this product or attached devices.

To disconnect:

1. Turn off everything (unless instructed otherwise).
2. Remove the power cords from the outlets.
3. Remove the signal cables from the connectors.
4. Remove all cables from the devices.

To connect:

1. Turn off everything (unless instructed otherwise).
2. Attach all cables to the devices.
3. Attach the signal cables to the connectors.
4. Attach the power cords to the outlets.
5. Turn on the devices.

(D005)

Caution notices

CAUTION:

The battery contains lithium. To avoid possible explosion, do not burn or charge the battery.

- Do not throw or immerse into water
- Do not heat to more than 100° C (212° F)
- Do not repair or disassemble

Exchange only with the IBM-approved part. Recycle or discard the battery as instructed by local regulations. In the United States, IBM has a process for the collection of this battery. For information, call 1-800-426-4333. Have the IBM part number for the battery unit available when you call. (C003)

CAUTION:

This part or unit is heavy but has a weight smaller than 18 kg (39.7 lb). Use care when lifting, removing, or installing this part or unit. (C008)

Use the following general safety information for all rack-mounted devices.

DANGER

Observe the following precautions when working on or around your IT rack system:

- Heavy equipment — personal injury or equipment damage might result if mishandled.
- Always lower the leveling pads on the rack cabinet.
- Always install stabilizer brackets on the rack cabinet.
- To avoid hazardous conditions due to uneven mechanical loading, always install the heaviest devices in the bottom of the rack cabinet. Always install servers and optional devices starting from the bottom of the rack cabinet.
- Rack-mounted devices are not to be used as shelves or workspaces. Do not place objects on top of rack-mounted devices.



- Each rack cabinet might have more than one power cord. Be sure to disconnect all power cords in the rack cabinet when directed to disconnect power during servicing.
- Connect all devices installed in a rack cabinet to power devices installed in the same rack cabinet. Do not plug a power cord from a device installed in one rack cabinet into a power device installed in a different rack cabinet.
- An electrical outlet that is not correctly wired could place hazardous voltage on the metal parts of the system. It could also place hazardous voltage on the devices that attach to the system. Ensure that the outlet is correctly wired and grounded to prevent an electrical shock.

(R001 part 1 of 2)

CAUTION:

- **Do not install a unit in a rack where the internal rack ambient temperatures could exceed the ambient temperature recommended by the manufacturer. Ensure that this temperature is not exceeded for all your rack-mounted devices.**
- **Do not install a unit in a rack where the air flow is compromised. Ensure that air flow is not blocked or reduced on any side, front, or back of a unit used for air flow through the unit.**
- **Plan the connection of the equipment to the supply circuit so that overloading of the circuits does not compromise the supply wiring or overcurrent protection. To provide the correct power connection to a rack, refer to the rating labels located on the equipment in the rack. Use the information provided on the labels to determine the total power requirement of the supply circuit.**
- **(For sliding drawers) Do not pull out or install any drawer or feature if the rack stabilizer brackets are not attached to the rack. Do not pull out more than one drawer at a time. The rack might become unstable if you pull out more than one drawer at a time.**
- **(For fixed drawers) This drawer is a fixed drawer and must not be moved for servicing unless specified by the manufacturer. Attempting to move the drawer out of the rack might cause the rack to become unstable. Attempting to move the drawer might also cause the drawer to fall out of the rack.**

(R001 part 2 of 2)

CAUTION:

Removing components from the upper positions in the rack cabinet improves rack stability during relocation. Follow these general guidelines whenever you relocate a populated rack cabinet within a room or building:

- Reduce the weight of the rack cabinet by removing equipment starting at the top of the rack cabinet. When possible, restore the rack cabinet to the configuration of the rack cabinet as you received it. If this configuration is not known, you must observe the following precautions:
 - Remove all devices in the 32U position and above.
 - Ensure that the heaviest devices are installed in the bottom of the rack cabinet.
 - Ensure that there are no empty U-levels between devices installed in the rack cabinet below the 32U level.
- If the rack cabinet you are relocating is part of a suite of rack cabinets, detach the rack cabinet from the suite.
- Inspect the route that you plan to take to eliminate potential hazards.
- Verify that the route that you choose can support the weight of the loaded rack cabinet. Refer to the documentation that comes with your rack cabinet for the weight of a loaded rack cabinet.
- Verify that all door openings are at least 760 x 230 mm (30 x 80 in.).
- Ensure that all devices, shelves, drawers, doors, and cables are secure.
- Ensure that the four leveling pads are raised to their highest position.
- Ensure that there is no stabilizer bracket installed on the rack cabinet during movement.
- Do not use a ramp inclined at more than 10 degrees.
- When the rack cabinet is in the new location, complete the following steps:
 - Lower the four leveling pads.
 - Install stabilizer brackets on the rack cabinet.
 - If you removed any devices from the rack cabinet, repopulate the rack cabinet from the lowest position to the highest position.
- If a long-distance relocation is required, restore the rack cabinet to the configuration of the rack cabinet as you received it. Pack the rack cabinet in the original packaging material, or equivalent. Also lower the leveling pads to raise the casters off the pallet and bolt the rack cabinet to the pallet.

(R002)

Labels

DANGER

Hazardous voltage, current, or energy levels are present inside any component that has this label attached. Do not open any cover or barrier that contains this label. (L001)



Preface

IBM WebSphere CloudBurst Appliance is a specialized hardware appliance that uses server virtualization, virtual appliances, and application infrastructure virtualization to deliver automation and optimization across the life cycle of WebSphere Application Server environments. WebSphere CloudBurst manages people (the users of the system), places (the servers, network and storage to run WebSphere applications), and things (virtual images, patterns, and virtual machines).

Who should read this document

This document is intended for people who are responsible for the following activities:

- Diagnosing and troubleshooting hardware problems
- Ordering consumable replacement parts
- Replacing parts

How this document is organized

This document has the following organization:

- Safety
Provides safety information for the WebSphere CloudBurst appliance.
- Chapter 1, "Introduction"
Provides the features and specifications for the WebSphere CloudBurst appliance.
- Chapter 2, "Diagnostics"
Provides information about the diagnostic features of a WebSphere CloudBurst appliance.
- Chapter 3, "Troubleshooting"
Provides information about troubleshooting hardware problems with a WebSphere CloudBurst appliance.
- Chapter 4, "Removing or replacing parts or the appliance"
Provides information about removing and replacing hardware, information about removing a WebSphere CloudBurst appliance from the rack, and information about finding and ordering replacement parts.
- "Getting help and technical assistance"
Provides information about getting additional support to diagnose a hardware problem.

Related documents

The documentation in the *IBM WebSphere CloudBurst Appliance: Information Center* is referenced by this document, but it is not on the *IBM WebSphere CloudBurst Appliance: Documentation CD*. You can find the *IBM WebSphere CloudBurst Appliance: Information Center* at the following location:

<http://publib.boulder.ibm.com/infocenter/wscloudb/v1r0/index.jsp>

The Documentation CD

The *IBM WebSphere CloudBurst Appliance: Documentation CD* contains documentation for your WebSphere CloudBurst appliance in Portable Document Format (PDF). This CD includes the documents listed in the “Available documents” on page xvii section and includes the IBM Documentation Browser to help you find information quickly.

Hardware and software requirements

The *IBM WebSphere CloudBurst Appliance: Documentation CD* requires the following minimum hardware and software:

- Microsoft Windows XP, Windows 2000, or Red Hat Linux
- 100 MHz microprocessor
- 32 MB RAM
- Adobe Acrobat Reader 3.0 (or later) or XPDF, which comes with Linux operating systems

Using the Documentation CD

Use the Documentation Browser to browse the contents of the CD, read brief descriptions of the documents, and view documents, using Adobe Acrobat Reader or XPDF. The Documentation Browser automatically detects the regional settings in use in your system and presents the information in the language for that region (if available). If a topic is not available in the language for that region, the English-language version is displayed.

Use one of the following procedures to start the Documentation Browser:

- If Autostart is enabled, insert the CD into the CD-RW/DVD drive. The Documentation Browser starts automatically.
- If Autostart is disabled or is not enabled for all users:

For Windows operating systems

1. Insert the CD into the CD-RW/DVD drive
2. Click **Start** → **Run**.
3. In the **Open** field, type `e:\win32.bat`; where *e* is the drive letter of your CD-RW/DVD drive
4. Click **OK**.

For Red Hat Linux operating systems

1. Insert the CD into the CD-RW/DVD drive
2. Run the following command from the `/mnt/cdrom` directory:

```
sh runlinux.sh
```

Select WebSphere CloudBurst from the **Product** menu. The **Available Topics** list displays all the documents for your product. Some documents might be in folders. A plus sign (+) indicates each folder or document that has additional topics under it. Click the plus sign to display the additional documents.

When you select a document, a description of the document appears under **Topic Description**. To select more than one document, press and hold the Ctrl key while you select the documents. Click **View Book** to view the selected document or documents in Acrobat Reader or XPDF. If you selected more than one document, all the selected documents are opened in Acrobat Reader or XPDF.

To search all the documents, type a word or word string in the **Search** field and click **Search**. The documents in which the word or word string appears are listed in order of the most occurrences. You can perform any of the following actions on the list:

- Click a document to view it.
- Press **Ctrl + F** to use the Acrobat search function.
- Press **Ctrl + Alt** to use the XPDF search function within the document.

Click **Help** for detailed information about using the Documentation Browser.

Available documents

The *IBM WebSphere CloudBurst Appliance: Documentation* CD contains the following documents:

- *IBM WebSphere CloudBurst Appliance: Quick Start Guide*
Provides basic instructions for installing and powering up the WebSphere CloudBurst appliance and placing the appliance in operation.
- *IBM WebSphere CloudBurst Appliance: Installation Guide*
Provides complete instructions for installing and powering up the WebSphere CloudBurst appliance, creating a startup configuration script, and placing the appliance in operation.
- *IBM WebSphere CloudBurst Appliance: Hardware Problem Determination and Service Guide*
Provides the following information about the features and specifications of the WebSphere CloudBurst appliance:
 - Diagnosing and troubleshooting hardware problems
 - Ordering, removing, and replacing hardware
 - Getting additional support to diagnose hardware problems
- *IBM Systems Safety Notices*
Contains all safety notices, by language, for the WebSphere CloudBurst appliance.
- *IBM Statement of Limited Warranty*
Contains information about the terms of warranty for the WebSphere CloudBurst appliance.

Warranty information

The product-specific *IBM Statement of Limited Warranty* for this product is provided on the *IBM WebSphere CloudBurst Appliance: Documentation* CD that comes with this product. The statement is also available in 29 languages from the IBM Web site at http://www.ibm.com/servers/support/machine_warranties/ without the product-specific terms.

Notices and conventions

The caution and danger statements in this document are also in the multilingual *IBM Systems Safety Notices* document, which is on the *IBM WebSphere CloudBurst Appliance: Documentation* CD. Each statement references the corresponding statement, in your language, in the *IBM Systems Safety Notices*.

The following notices and statements are used in this document:

Note These notices provide important tips, guidance, or advice.

Best Practice

These notices provide guidance about how to best accomplish a task.

Attention

These notices indicate potential damage to programs, devices, or data. An attention notice is placed just before the instruction or situation in which damage might occur.

Caution

These statements indicate situations that can be potentially hazardous to you. A caution statement is placed just before the description of a potentially hazardous procedure step or situation.

Danger

These statements indicate situations that can be potentially lethal or hazardous to you. A danger statement is placed just before the description of a potentially lethal or hazardous procedure step or situation.

Typeface conventions

The following typeface conventions are used in the documentation:

bold Identifies commands, programming keywords, and GUI controls.

italics Identifies words and phrases used for emphasis and user-supplied variables.

monospaced

Identifies user-supplied input or computer output.

Chapter 1. Introduction

IBM WebSphere CloudBurst Appliance is a 1U rack-mountable appliance.

Specifications and features

This section contains information about the specifications and features of the WebSphere CloudBurst appliance.

Specifications

Table 1 summarizes the specifications for the dimensions of the WebSphere CloudBurst appliance chassis.

Table 1. Appliance dimensions

Specification	Measurement
Height	1.7 inches (4.32 cm)
Specification	Measurement
Width	19 inches (48.25 cm) 19.13 inches (48.59 cm) with rails
Depth	28.12 inches (71.42 cm) 33.05 inches (83.94 cm) with rails
Weight	Maximum: 37.48 lb. (17 kg)

Table 2 summarizes the electrical requirements for the WebSphere CloudBurst appliance.

Table 2. Electrical requirements

Specification	Measurement
Sine-wave	50 - 60 Hz, single-phase, required
110 Voltage AC	Minimum: 100 V _{RMS} Maximum: 127 V _{RMS}
220 Voltage AC	Minimum: 200 V _{RMS} Maximum: 240 V _{RMS}
Heat output	Maximum: 590 watts (2014 Btu) per hour

Table 3 summarizes the environmental requirements for the WebSphere CloudBurst appliance.

Table 3. Appliance specifications

Specification	Requirement
Air temperature	Turned on: <ul style="list-style-type: none">Altitude 0 feet to 3000 feet (0 m to 914.4 m) 50° to 95° F (10° to 35° C)Altitude: 3000 feet (914.4 m) to 7000 feet (2133.6 m) 50° to 89.6° F (10° to 32° C) Maximum altitude: 7000 feet (2133.6 m) Turned off: 50° to 109.4° F (10° to 43° C) Shipping: -40° to 140° F (-40° to 60° C)
Humidity	8% to 80%

Table 3. Appliance specifications (continued)

Specification	Requirement
Fan acoustics	<p>Front: $L_A=50$ dB to $L_A=64$ dB</p> <p>Rear: $L_A=51$ dB to $L_A=66$ dB</p> <p>The lower limits indicate the fans during normal operating conditions. The upper limits indicate the fans during startup or high temperature situations.</p>
Power level acoustics	65 dB to 79 dB, Declared

Features

The WebSphere CloudBurst appliance provides the hard-disk array for data storage. This hard-disk array is a simple swap Serial Attached SCSI (SAS) hard-disk drive. The specifications shown in Table 4.

Table 4. Serial Attached SCSI (SAS) hard disk drive specifications

Feature	Value
Capacity	146 GB
Speed	10 K RPM
Interface	SAS
Cache	16 MB
RAID	1
Configuration	RAID 1 (mirrored)
Output	25 watts per drive

Components

The WebSphere CloudBurst appliance includes data storage, a system battery, fan modules, and power modules.

Front view

No components are installed from the front of a WebSphere CloudBurst appliance. Figure 1 shows the components on the front panel of a WebSphere CloudBurst appliance.

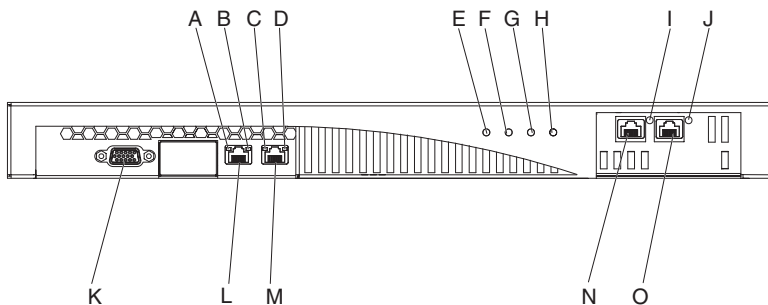

Figure 1. Front view

The labels in Figure 1 represent the following components on the front panel of a WebSphere CloudBurst™ appliance:

- A The *activity* LED light for the MGMT Ethernet interface.
- B The *speed* LED light for the MGMT Ethernet interface.
- C The *activity* LED light for the ETH0 Ethernet interface.
- D The *speed* LED light for the ETH0 Ethernet interface.
- E The *power* LED light.
- F The *storage* LED light.
- G This LED light is not operational in IBM WebSphere CloudBurst Appliance version 1.0.0.
- H The *error alarm* LED light.
- I The *activity* LED light for the ETH2 Ethernet interface.
- J The *activity* LED light for the ETH1 Ethernet interface.
- K The CONSOLE connector.
- L The network connector to the MGMT Ethernet interface.
- M The network connector to the ETH0 Ethernet interface.
- N The network connector to the ETH2 Ethernet interface.
- O The network connector to the ETH1 Ethernet interface.

CONSOLE connector

The front panel of the WebSphere CloudBurst appliance has the CONSOLE connector. The serial cable that is shipped with the appliance connects to it from:

- An ASCII terminal, a simple device that transmits and receives ASCII data
- A PC that is running terminal emulation software to the appliance

Network connectors

The front panel of the WebSphere CloudBurst appliance has the following Ethernet connectors:

MGMT Ethernet connector

This Ethernet interface can manage all transaction data on the appliance. This connection has the following associated activity LED and speed LED lights:

Activity LED light

When illuminated, this light indicates that traffic is passing through this connection.

Speed LED light

This light indicates Ethernet connection speed and status.

ETH0 Ethernet connector

This Ethernet interface can manage all transaction data on the appliance. This connection has the following associated activity LED and speed LED lights:

Activity LED light

When illuminated, this light indicates that traffic is passing through this connection.

Speed LED light

This light indicates Ethernet connection speed and status.

ETH1 Ethernet connector

This Ethernet interface can manage all transaction data on the appliance.

ETH2 Ethernet connector

This Ethernet interface can manage all transaction data on the appliance.

LED lights

The front panel of the WebSphere CloudBurst appliance has the following LED lights:

Power LED light

The green power LED light is illuminated when the appliance is connected to a power source and the power switch is in the ON position.

Storage LED light

The green storage LED light is illuminated when data storage is being accessed.

Error alarm LED light

The yellow error alarm LED light is illuminated when any LED light on the rear of the appliance is illuminated or after a system event failure.

Rear view

The data storage, system battery, fan modules, and power modules are installed from the rear of the WebSphere CloudBurst appliance. Figure 2 shows the components on the rear panel of the WebSphere CloudBurst appliance.

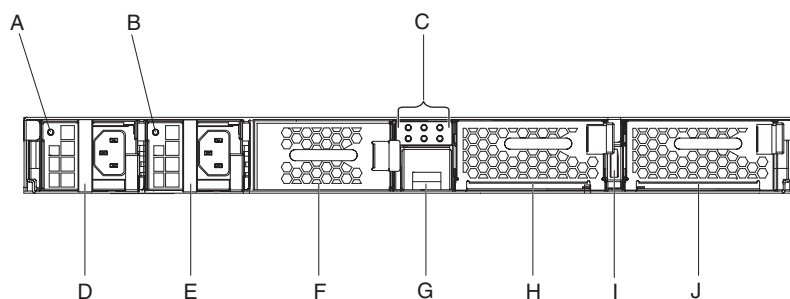

Figure 2. Rear view

The labels in Figure 2 represent the following components on the rear panel of a WebSphere CloudBurst appliance:

- A The power supply 1 LED light.
- B The power supply 2 LED light.
- C The LED diagnostic panel.
- D The power supply module 1.
- E The power supply module 2.
- F The data storage unit: hard-disk array.
- G The battery tray.
- H The fan module 2.
- I The power switch.
- J The fan module 1.

Power supply modules

The WebSphere CloudBurst appliance is powered by two fully redundant 650 watt power supply modules. A single power supply module can supply enough power to support appliance operations. The power supply modules can be *hot-swapped*, which means that you can replace a single power supply module without stopping the appliance.

Each power supply module contains two fans. Failure of at least one fan causes the power supply module to overheat and generate messages.

At the rear of the appliance, each power supply module has an LED light that indicates its operational state.

Data storage unit

The WebSphere CloudBurst appliance comes with the hard-disk array to provide data storage. The hard-disk array is part the hard-disk drive module. This module contains two 146 GB disks in a Redundant Array of Independent Disks (RAID) configuration and two fans. The disks operate as a single, mirrored volume. The disks cannot be used as two discrete disks.

If one of the fans becomes inoperable, replace the hard-disk drive module. A replacement hard-disk drive module does not contain the disks. For a replacement hard-disk drive module, you use the existing disks. If an individual disk becomes inoperable, you can replace that disk.

LED diagnostic panel

The rear panel of the WebSphere CloudBurst appliance includes an LED diagnostic panel with six LED lights. The layout is three LED lights in two rows, as shown in Figure 3.

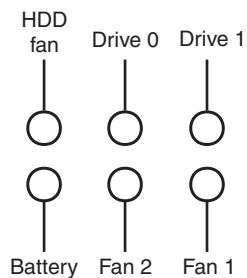

Figure 3. Diagnostic panel

Table 5 provides the meaning for each LED light.

Table 5. LED diagnostic panel

Position of light	Meaning
HDD fan, top row, left	The state of the fans in the hard-disk drive module
Drive 0, top row, center	The state of the Drive 0 hard-disk
Drive 1, top row, right	The state of the Drive 1 hard-disk
Battery, bottom row, left	The state of the battery
Fan 2, bottom row, center	The state of the fans in the fan module 2
Fan 1, bottom row, right	The state of the fans in the fan module 1

Battery

The appliance is equipped with a CR2 3 V lithium battery. The battery cannot power the appliance. The appliance must be connected to active ac power sources for the appliance to process transactions. The battery maintains only the following internal components:

- The real-time clock
- Static RAM-based memory, that contains various global parameters which include the current date and time for the appliance

Attention: Complete power failure, for example caused by no ac power to the appliance with a missing or depleted battery, for 7 days activates the intrusion switch. Activation of the intrusion switch renders the appliance inoperable. To prevent having to return the appliance to IBM for remanufacturing, ensure that you have a backup source of power for your appliance and inspect the primary and secondary sources regularly, at least weekly. Leave the appliance connected to active ac power sources. Do not turn off the appliance when the battery needs to be replaced.

Both the firmware and the hardware monitor the battery:

Firmware

The firmware monitors the age of the battery from its installation date. During a firmware reload, the firmware reads the current timestamp. If more than two years has elapsed, the firmware generates a critical message. The firmware continues to generate this message at 24-hour intervals until you replace the battery. Shortly before you receive your appliance, the battery time-tracking process is initialized.

Hardware

The hardware monitors the capacity of the battery. The hardware generates critical messages when the capacity is less than 10%.

Fan modules

The appliance provides two fan modules. Each fan module holds four individual fan motors. If one fan motor fails, you must replace the entire fan module to maintain the required air flow.

The fans typically operate between the cold chassis speeds and maximum speeds. The failure threshold is set to a speed that is 20% lower than the cold chassis speed.

Table 6 lists the speeds for the front and rear fans in revolutions per minute (RPM) on the appliance.

Table 6. Fan speeds in RPM

	Minimum	Cold chassis	Maximum	Failure threshold	Number of blades
Front	2900	5280	16100	2000	5
Rear	2300	4880	12400	2000	4

Chapter 2. Diagnostics

Before you perform maintenance on this product, read the safety information in "Safety" on page v.

LED lights

There are LED lights on the front and rear of the WebSphere CloudBurst appliance.

Front panel

Figure 4 shows the LED lights on the front on the appliance.

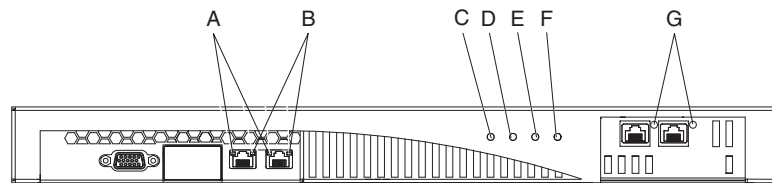

Figure 4. LED lights on the front on the appliance

The front of the appliance has the following LED lights:

- A** The activity LED light for the Ethernet interface indicates when traffic is passing through the interface.
 - If illuminated, traffic is passing through the interface.
 - If not illuminated, no traffic is passing through the interface.
- B** The speed LED light for the Ethernet interface indicates the connection speed.
 - If the LED light is illuminated in green, the connection speed is 1 Gbps.
 - If the LED light is illuminated in amber, the connection speed is 100 Mbps.
 - If not illuminated, the connection speed is 10 Mbps or there is no connection. If the speed LED light is not illuminated but the activity LED light blinks, the connection speed is 10 Mbps.
- C** The green power LED light indicates whether the appliance is connected to a power source.
 - If illuminated, the appliance is connected to a power source and the power switch is in the ON position.
 - If not illuminated, the power of the appliance is in one of the following states:
 - No power source is available
 - The power switch is in the OFF position
 - Both power supply modules have failed
- D** The green data storage LED light indicates when data storage is being accessed.
 - If illuminated, data storage is being accessed.
 - If not illuminated, data storage is not being accessed.
- E** This LED light is not operational in IBM WebSphere CloudBurst Appliance version 1.0.0.

- F The yellow error alarm LED light indicates an error condition.
 - If illuminated, at least one of the following conditions is met:
 - A power supply module failure.
 - A fan module failure.
 - Any of the LED lights at the rear of the appliance is illuminated. The previous conditions indicate the need to replace that part. The following conditions indicate the need for additional troubleshooting.
 - Any other system event failure in the appliance.
 - If not illuminated, none of these conditions exist.
- G The activity LED light for the Ethernet interface indicates when the interface is active and when traffic is passing through the interface.
 - If illuminated, the interface is active.
 - If blinking, traffic is passing through the interface.

Rear panel

Figure 5 shows the LED lights on the rear on the appliance.

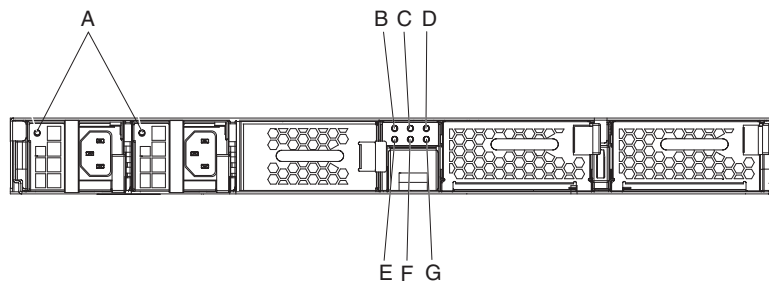

Figure 5. LED lights on the rear on the appliance

The rear of the appliance has the following LED lights:

- A The single bicolored LED light indicates the state of the power supply module.
 - If not illuminated, the power supply module has no AC power.
 - If illuminated in green, the power supply module is operating normally. The power supply module has AC power, and the appliance is turned on.
 - If blinking in green at one-second intervals, the power supply module has AC power, but the appliance is turned off.
 - If illuminated in amber, a power supply unit triggers one of the following critical events that causes a shutdown:
 - Overcurrent protection (OCP), which is a protection circuit that protects the power source from an over current condition that could occur from the load.
 - Over-voltage protection (OVP), which is a protection circuit that protects the power source from an over voltage condition that could occur from the load.
 - Power supply fan failure.
 - AC out of range.
 - No AC power to this power supply unit.

- If blinking in amber at one-second intervals, a power supply unit triggers one of the following warning events where the power supply continues to operate:
 - High temperature
 - High power
 - High current
 - Slow power supply fan

B through G

The LED diagnostics panel. Table 7 and Table 8 list what each LED light represents.

Table 7. Top row of the LED diagnostics panel on rear panel

Top row, left to right
The state of the fans in the hard disk drive module ¹
The state of the Drive 0 hard disk
The state of the Drive 1 hard disk
¹ Contains the following fans as shown in output or in log messages: <ul style="list-style-type: none"> • Hard disk drive tray fan 1 or chassis cooling fan 9 • Hard disk drive tray fan 2 or chassis cooling fan 10

Table 8. Bottom row of the LED diagnostics panel on rear panel

Bottom row, left to right
The state of the battery
The state of the fans in the fan module 2 ²
The state of the fans in the fan module 1 ³
² Contains the following fans as shown in output or in log messages: <ul style="list-style-type: none"> • Fan tray 2 fan 1 or chassis cooling fan 5 • Fan tray 2 fan 2 or chassis cooling fan 6 • Fan tray 2 fan 3 or chassis cooling fan 7 • Fan tray 2 fan 4 or chassis cooling fan 8
³ Contains the following fans as shown in output or in log messages: <ul style="list-style-type: none"> • Fan tray 1 fan 1 or chassis cooling fan 1 • Fan tray 1 fan 2 or chassis cooling fan 2 • Fan tray 1 fan 3 or chassis cooling fan 3 • Fan tray 1 fan 4 or chassis cooling fan 4

Each LED light, except the battery LED light, indicates that state of the component (storage card, hard disk module, individual disks, or fan module).

- If illuminated in yellow, the component is failing, has failed, or has been removed.
- If not illuminated, the component is operational.

The battery LED light indicates the capacity of the battery.

- If illuminated, the capacity is less than 10%.
- If not illuminated, the capacity is greater than 10%.

Testing the hardware from the command line

You can use the Global **test hardware** command to test the hardware from the command line. To use this command:

- You need to be able to establish a connection to the appliance using SSH.
- You are in Global configuration mode (the **configure terminal** command).

To test the hardware from the configuration, enter the following commands:

```
# configure terminal
(config)# test hardware
```

Depending on the state of the hardware, the command produces output that states the status for each component:

- success
- warning
- failure

The components are broken down into the following categories:

- Backtrace availability
- Interface diagnostics
- Fan diagnostics
- Cryptographic card diagnostics

Samples of success statements are as follows:

- [success] Backtrace file does not exist
- [success] 4 interface expected - 4 interfaces found
- [success] MAC address of interface 'eth0' is 00:11:25:27:bf:e7
- [success] Statistics for interface 'eth0' show no errors
- [success] 6 fans expected - 6 fans found
- [success] fan 1 operating within expected range
- [success] Status of the crypto 'standard' is fully operational

Samples of warning statements are as follows:

- [warning] Backtrace file exists.
- [warning] Physical link on interface 'eth0' is down.
- [warning] eth1 has invalid MAC (ff:ff:ff:ff:ff)

Samples of failure statements are as follows:

- [failure] Expected number of interfaces: 4 - Found: 1
- [failure] fan 2 operating outside expected range (rpm too low)
- [failure] Status of crypto 'not detected' is unknown.

The output of the **test hardware** command is included in any generated error report. Refer to the command information in the *IBM WebSphere CloudBurst Appliance: Information Center* for more information about the **test hardware** command.

Viewing status providers for sensors

The WebSphere CloudBurst appliance provides the following sensors status providers:

Fan sensors

Provides the measured speed in revolutions per minute (RPM) for each of the four fans in each fan module. For the hard disk array configuration, it also provides the measured speed for each of the two fans in the hard disk drive module.

From the command line, enter **show sensors-fans**.

Temperature sensors

Provides the measured temperature in degrees Celsius for the following internal components:

- Temperature of each of the two internal CPU components
- Temperature of each of the four internal memory components
- Temperature of each of the two internal system components

From the command line, enter **show sensors-temperature**.

Voltage sensors

Provides the measured voltage for the following internal components:

- Voltage +1.5
- Voltage +1.8
- Voltage +12
- Voltage +3.3
- Voltage +5
- Voltage +5 Standby
- Voltage Battery
- Voltage Bus Termination
- Voltage CPU 1 Core
- Voltage CPU 2 Core

From the command line, enter **show sensors-voltage**. The voltage is measured in millivolts.

Other sensors

Provides truth values for the intrusion switch, each of the two power supply modules, and the battery. For the hard disk array configuration, it also provides truth values for each of the two disks in the array.

- A value of true indicates that the condition exists.
- A value of false indicates that the conditions does not exist.

For the intrusion switch, the value indicates whether it has been tripped.

For each power supply, the values indicate the following conditions:

- AC Lost
- Fan Slow
- High Temperature
- Not Enabled
- Output Failure
- Over-Temperature
- Present

For each hard disk in the array and the battery, the values indicate the following conditions:

- Fault
- Present

From the command line, enter **show sensors-other**.

Chapter 3. Troubleshooting

Troubleshooting is a systematic approach to solving a problem. The goal of troubleshooting is to determine why something does not work as expected and to explain how to resolve the problem. To begin troubleshooting hardware problems with the appliance, use the procedure in “Troubleshooting workflow.” This procedure guides you to the appropriate troubleshooting task.

Troubleshooting workflow

To help you troubleshoot the problem and determine whether you need to contact IBM Support for assistance or to order a replacement part, use the following workflow:

1. Does the log file contain a critical message?

For information about viewing logs, refer to the viewing logs topic in the *IBM WebSphere CloudBurst Appliance: Information Center*.

Yes Continue to step 2.

No Continue to step 3 on page 14.

2. Does the critical event or critical log message identify the part that is failing or has failed?

Yes Continue troubleshooting to determine whether you need a replacement part:

- If a fan module, refer to “Troubleshooting fan modules” on page 15.
- If the power supply module, refer to “Troubleshooting the power supply module” on page 15.
- If the hard disk drive module, refer to “Troubleshooting the hard disk drive module” on page 15.
- If one of the individual disks, refer to “Troubleshooting individual disks” on page 16.
- If the battery, refer to “Troubleshooting the battery” on page 16.

No Continue to step 3 on page 14.

3. Is the error alarm LED light illuminated on the front of the appliance?



Yes Continue with step 4.

No Refer to “Troubleshooting the appliance” on page 17.

4. Are any of the LED lights in the LED diagnostics panel illuminated, or is a power supply module LED light on the rear of the appliance illuminated or blinking in amber or not illuminated?

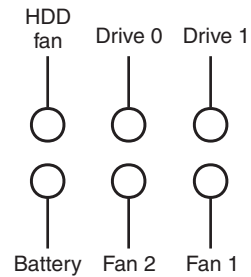

For information about these LED lights, refer to “LED diagnostic panel” on page 5.

Yes Refer to the appropriate part-specific troubleshooting topic:

- If the Fan 1 or Fan 2 LED light in diagnostics panel (a fan module), refer to “Troubleshooting fan modules” on page 15.
- If the power supply LED light on power supply module (a power supply module), refer to “Troubleshooting the power supply module” on page 15.
- If the hard disk drive module (HDD fan LED light in diagnostics panel (a hard disk drive module), refer to “Troubleshooting the hard disk drive module” on page 15.
- If the Drive 0 or Drive 1 LED light in diagnostics panel (one of the individual hard disks), refer to “Troubleshooting individual disks” on page 16.
- If the Battery LED light in the diagnostics panel (a Battery module), refer to “Troubleshooting the battery” on page 16.

No Refer to “Troubleshooting the appliance” on page 17.

Troubleshooting CRU parts

Use the following procedures to troubleshoot a CRU part:

- “Troubleshooting fan modules” on page 15
- “Troubleshooting the power supply module” on page 15
- “Troubleshooting the hard disk drive module” on page 15
- “Troubleshooting individual disks” on page 16

Troubleshooting fan modules

To troubleshoot fan modules, use the **show sensors-fans** command.

- If the output shows that all four fans are running at 0 RPM, the fan module is not seated correctly in the appliance.
- If the output shows that at least one fan is running at less than 2000 RPM, contact IBM Support.

Note: Turn off the appliance as soon as possible to avoid overheating. The remaining fans might not be able to maintain the appropriate environmental temperature.

If the module is not seated correctly, generally it is not locked in place. To ensure that the module is seated, use the appropriate steps in “Replacing a fan module” on page 23 to remove and reinsert the module.

If you believe that the module needs to be replaced, contact IBM Support. For information about contacting IBM Support and the information that you need before contacting IBM Support, refer to “Getting help and technical assistance,” on page 37.

Troubleshooting the power supply module

To troubleshoot the power supply, the LED light on the power supply module indicates whether it needs to be replaced.

- If the LED light is not illuminated, the power supply module is not connected to an AC power source or the power supply module is not seated correctly in the appliance.
- If the LED light is illuminated in amber or blinking in amber, the power supply module might need to be replaced.

Note: Remove the power cord from the power supply module. The appliance can operate with a single power supply module.

If the module is not seated correctly, generally it is not locked in place. To ensure that the module is seated, use the appropriate steps in “Replacing a power supply module” on page 25 to remove and reinsert the module.

If the module does not have AC power, ensure that the power cords are connected correctly to the power supply and to a working AC power outlet.

If you believe that the module needs to be replaced, contact IBM Support. For information about contacting IBM Support and the information that you need before contacting IBM Support, refer to “Getting help and technical assistance,” on page 37.

Troubleshooting the hard disk drive module

To troubleshoot the hard disk drive module, use the **show sensors-fans** command.

- If the output shows that both fans are running at 0 RPM, the hard disk drive module is not seated correctly in the appliance.
- If the output shows that at least one fan is running at less than 2000 RPM, contact IBM Support.

Note: Turn off the appliance as soon as possible to avoid overheating. The remaining fans might not be able to maintain the appropriate environmental temperature.

If the module is not seated correctly, generally it is not locked in place. To ensure that the module is seated, use the appropriate steps in “Replacing the hard disk drive module” on page 26 to remove and reinsert the module.

If you believe that the module needs to be replaced, contact IBM Support. For information about contacting IBM Support and the information that you need before contacting IBM Support, refer to “Getting help and technical assistance,” on page 37.

Troubleshooting individual disks

To troubleshoot the individual disks in the hard disk drive module, use the **show raid-phys-disks** command.

- If the output shows **Missing for State**, the physical disk is missing or not responding. The disk is not available to the RAID volume. The disk might need to be replaced.
- If the output shows **Not Compatible for State**, the physical disk is present, but it is not compatible with the RAID Volume. The disk could be too small or could be the wrong type of disk. The disk might need to be replaced.
- If the output shows **Failed for State**, the physical disk is present, but it has failed. The failure could be from too many read or write errors. The disk might need to be replaced.
- If there is no output, the hard disk drive module is not seated correctly in the appliance. To ensure that the module is seated, use the appropriate steps in “Replacing the hard disk drive module” on page 26 to remove and reinsert the module.

If you believe that an individual disk needs to be replaced, contact IBM Support. For information about contacting IBM Support and the information that you need before contacting IBM Support, refer to “Getting help and technical assistance,” on page 37.

Troubleshooting consumable parts

Use the following procedures to troubleshoot a consumable part:

- “Troubleshooting the battery”

Consumable parts are not covered by the IBM Statement of Limited Warranty. For information about the terms of warranty, see the *IBM Statement of Limited Warranty* document on the *IBM WebSphere CloudBurst Appliance: Documentation*.

Troubleshooting the battery

The battery cannot power the appliance. The appliance must be connected to active AC power sources for the appliance to process transactions. The battery maintains the following internal components only:

- The real time clock
- Static RAM-based memory, which contains various global parameters that include the current date and time for the appliance

Attention: Complete power failure (no AC power to the appliance with a missing or depleted battery) for seven days renders the appliance inoperable by activating the intrusion switch. After seven days, you might need to return the appliance to IBM to have the intrusion switch reset.

Leave the appliance connected to active AC power sources. Do not turn off the appliance when the battery needs to be replaced.

To troubleshoot the battery, use the **show sensors-voltage** command.

- If the output shows 0 for Voltage Battery, the battery is not seated correctly in the appliance.
- If the output shows less than 2.592 volts for Voltage Battery, the battery needs to be replaced.
- If the two-year lifecycle of the battery has expired, replace the battery. To check initialization date of the battery, use the **show battery** command.

If the battery is not seated correctly, generally it is placed backward in the carriage. To ensure that battery is seated, use the appropriate steps in “Replacing the battery” on page 30 to remove and reinsert the battery.

If the battery needs to be replaced, use the following procedure to purchase a battery:

1. Go to <http://www.ibm.com>.
2. From the **Products** menu, click **Upgrades, accessories & parts**.
3. Click **Obtain maintenance parts**.
4. Order part number 44X0512 from the retail store.

If you need help with your order, call the toll-free number that is listed on the retail parts Web page or contact your local IBM representative for assistance with the purchase.

Troubleshooting the appliance

If you can connect to the appliance from the command line, use the following procedures to troubleshoot the appliance:

1. Connect to the appliance from the command line.
2. Run the **test hardware** command.
For information about the **test hardware** command, refer to “Testing the hardware from the command line” on page 10.
3. Check the output for warning and failure messages.
4. Contact IBM Support. For information about contacting IBM Support and the information that you need before contacting IBM Support, refer to “Getting help and technical assistance,” on page 37.

If you cannot connect to the appliance from the command line, use the following procedure to troubleshoot the appliance:

1. Turn off the appliance by toggling the power switch to the OFF position.
2. Use the included serial cable to connect the terminal or PC to the CONSOLE connector on the appliance. If the terminal or PC does not have a serial port and has only a USB port, then use a USB-to-serial adapter (not included).

3. Ensure that the terminal or PC is configured for standard 9600 8N1 and no flow control operation. 8N1 is a notation for a serial configuration in asynchronous mode, where there are eight (8) data bits, no (N) parity bit, and one (1) stop bit.
4. Turn on the appliance by toggling the power switch to the ON position.
You should see the green power LED light illuminate on the front of the appliance and hear the fans start up.
You should hear the fans change speed as the screen displays the following message:
DPOS
Loading system...
5. Wait for a few seconds for the appliance to boot.
6. If the appliance demonstrates any of the following symptoms, contact IBM Support:
 - The screen does not display the following message:
DPOS
Loading system...
 - The appliance boots in "Fail Safe" mode
 - The appliance does not bootFor information about contacting IBM Support and the information that you need before contacting IBM Support, refer to "Getting help and technical assistance," on page 37.

Chapter 4. Removing or replacing parts or the appliance

The WebSphere CloudBurst appliance includes the Tier 1 customer replaceable unit (CRU) replacement parts. Replacement parts for IBM machine types can be of the following types:

Tier 1 CRU

Replacement of a Tier 1 CRU is your responsibility. If an IBM representative installs a Tier 1 CRU at your request, you will be charged for the installation.

Tier 2 CRU

Replacement of a Tier 2 CRU can be installed by you or can be installed at your request by an IBM representative if under warranty. If installed by an IBM representative while under warranty, you will not be charged for the installation.

Field replaceable unit (FRU)

FRU parts must be installed by trained service technicians only.

For information about the terms of warranty, see the *IBM Statement of Limited Warranty* document on the *IBM WebSphere CloudBurst Appliance: Documentation*.

For information about obtaining service or assistance, refer to "Getting help and technical assistance," on page 37.

Installation guidelines

Before you remove or replace a component, read the following information:

- Read "Handling static-sensitive devices" on page 20 and "Safety" on page v. This information will help you work safely.
- Observe good housekeeping in the area where you are working. Place removed parts in a safe place.
- You do not have to disconnect the WebSphere CloudBurst appliance from power to install or replace any hot-swap module.
- Ensure that you have an adequate number of properly grounded electrical outlets for the WebSphere CloudBurst appliance.
- Have a medium Phillips screwdriver available.
- Orange on a component indicates that the component can be hot-swapped. You can remove or install the component while the WebSphere CloudBurst appliance is running. Orange can also indicate touch points on hot-swap components. See the instructions for removing or installing a specific hot-swap component for additional procedures that you might have to perform before you remove or install the component.
- Blue on a component indicates touch points, where you can grip the component to remove it from or install it in the WebSphere CloudBurst appliance, open or close a latch, and so forth.

Handling static-sensitive devices

Read the following guidelines before handling static-sensitive devices.

Attention: Static electricity can damage the WebSphere CloudBurst chassis and other electronic devices. To avoid damage, keep static-sensitive devices in their static-protective packages until you are ready to install them.

To reduce the possibility of electrostatic discharge, observe the following precautions:

- Limit your movement. Movement can cause static electricity to build up around you.
- The use of a grounding system is recommended. For example, wear an electrostatic-discharge wrist strap, if one is available.
- Handle the device carefully, holding it by its edges or its frame.
- Do not touch solder joints, pins, or exposed circuitry.
- Do not leave the device where others can handle and damage it.
- While the device is still in its static-protective package, touch it to an unpainted metal part of the WebSphere CloudBurst chassis or rack for at least 2 seconds. This drains static electricity from the package and from your body.
- Remove the device from its package and install it immediately without setting down the device. If it is necessary to set down the device, put it back into its static-protective package.
- Take additional care when you handle devices during cold weather. Heating reduces indoor humidity and increases static electricity.

Returning a appliance or component

If you are instructed to return an appliance or component, follow all packaging instructions and use any of the packaging materials for shipping that is supplied to you.

Note: You might be charged for the replacement appliance or component if IBM does not receive the defective appliance or component within 15 days of your receipt of the replacement.

Parts listing

The WebSphere CloudBurst appliance includes Tier 1 CRU replaceable parts only.

For information about the terms of warranty, see the *IBM Statement of Limited Warranty* document on the *IBM WebSphere CloudBurst Appliance: Documentation CD*.

For information about obtaining service or assistance, refer to "Getting help and technical assistance," on page 37.

Rear parts listing

The rear of the WebSphere CloudBurst appliance contains components such as the power supply module, fan modules, data storage, and system battery.

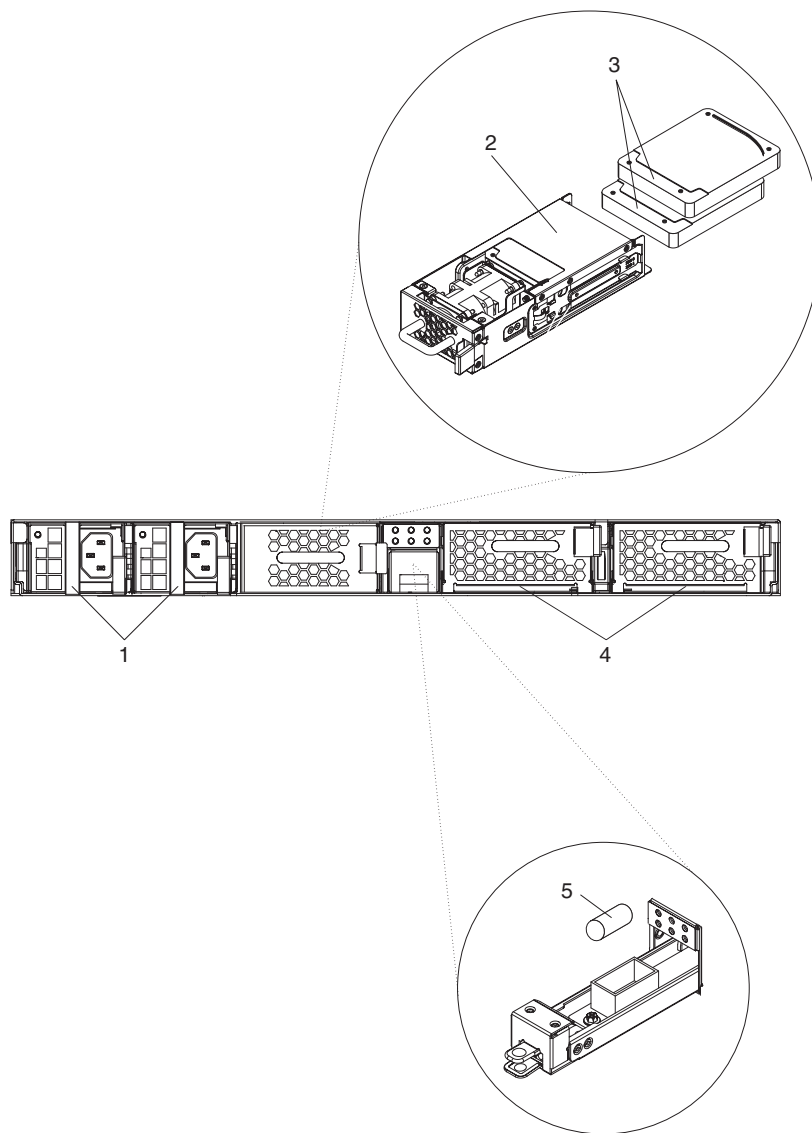

Table 9 lists the part numbers and their corresponding descriptions.

Table 9. Part numbers

Index	Description	Tier 1 CRU part number
1	Power supply, 650 watts	44X0542
2	Hard disk drive module, without disks	44X0535
3	Hard disk drive, SAS 146 GB storage	42D0422
4	Fan module, with service cards	46C1283
5	Battery, system ¹	
	Serial console cable	46M0494
	Rack-mounting kit	44R5787
	Service cards	44R5812
	Fan module assembly	44E7727
1	This part is consumable. See “Consumable parts listing” on page 22 for details.	

Consumable parts listing

The parts in Table 10 are consumable parts and are available for purchase from the retail store.

Table 10. Consumable parts

Description	Part number
Battery, system	44X0512

To order a consumable part, use the following procedure:

1. Go to <http://www.ibm.com>.
2. From the **Products** menu, click **Upgrades, accessories & parts**.
3. Click **Obtain maintenance parts**.
4. Follow the instructions to order the part from the retail store.

If you need help with your order, call the toll-free number that is listed on the retail parts page or contact your local IBM representative for assistance.

Consumable parts are not covered by the IBM Statement of Limited Warranty. For information about the terms of warranty, see the *IBM Statement of Limited Warranty* document on the *IBM WebSphere CloudBurst Appliance: Documentation*.

Power cords

Table 11 lists the power cord Tier 1 CRU part numbers.

Table 11. Power cords

Country	Tier 1 CRU part number	Description
Argentina	39M5068	2.8m, 10A/250V, C13 to IRAM 2073
Australia / New Zealand	39M5102	2.8m, 10A/250V, C13 to AS/NZ 3112
Brazil	39M5233	2.8m, 10A/125V, C13 to IEC320
Chile	39M5165	2.8m, 220 - 240V
China	39M5206	2.8m, 10A/250V, C13 to GB 2099.1
Denmark	39M5130	2.8m, 10A/250V, C13 to DK2-5a
Europe	39M5123	2.8m, 10A/250V, C13 to IEC 309 Type 2P+Gnd
	39M5179	2.8m, 10A/250V, C13 to IEC320 Inline
India	39M5226	2.8m, 10A/250V, C13 (2P +Gnd)
Israel	39M5172	2.8m, 10A/250V, C13 to SI 32
Italy	39M5165	2.8m, 220 - 240V
Japan	39M5199	2.8m, 12A/100V, C13 to JIS C-8303
Korea	39M5219	2.8m, 12A/250V, C13 to KETI
South Africa	39M5144	2.8m, 10A/250V, C13 to SABS 164
Switzerland	39M5158	2.8m, 10A/250V, C13 to SEV 1011-S24507
Taiwan	39M5247	2.8m, 10A/125V, C13 to CNS 10917-3
United Kingdom	39M5151	2.8m, 10A/250V, C13 to BS 1363/A
United States	39M5081	2.8m, 10A/250V, C13 to NEMA 6-15P

Model type

The part number for the replacement WebSphere CloudBurst appliance model type is 49Y4700.

Turning off the appliance

If a replacement procedure requires that the appliance be turned off, use the following procedure to turn off power to the appliance:

1. Shut down the appliance. From WebGUI, use the following procedure:
 - a. Select **Appliance** → **Settings** → **Power**.
 - b. Click **Shut down the appliance**.
 2. Turn off the appliance by toggling the power switch to the OFF position. The power switch is on the rear of the chassis.
-

Removing and replacing CRU parts

Replacement of Tier 1 CRU parts is your responsibility. If an IBM representative installs a Tier 1 CRU part at your request, you will be charged for the installation.

Use the following hardware maintenance procedures to remove and replace a CRU part:

- “Replacing a fan module”
- “Replacing a power supply module” on page 25
- “Replacing the hard disk drive module” on page 26
- “Replacing individual disks” on page 28

Replacing a fan module

You need to turn off the appliance and replace a fan module when the following events occur:

- After the appliance generates a critical message that indicates a fan failure. The message identifies which fan module to replace.
- When the following LED lights are illuminated:
 - The error alarm LED light on the front of the chassis is illuminated in yellow.

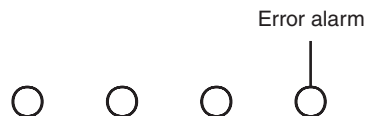

- One of the fan LED lights on the rear of the chassis is illuminated in yellow. The illuminated LED light indicates which fan module needs to be replaced.

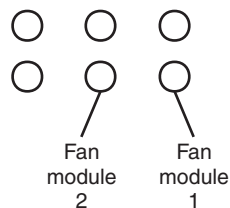

Best Practice: Turn off the appliance as soon as possible to avoid overheating. The remaining fans might not be able to maintain the appropriate environmental temperature.

To replace a failed fan module at the rear of the chassis, use the following procedure:

1. If the appliance is not turned off, turn off the appliance by toggling the power switch to the OFF position. The power switch is on the rear of the chassis.
2. Unplug all power cords.
3. Firmly grip the handle of the failed module.

Figure 6 illustrates the following steps.

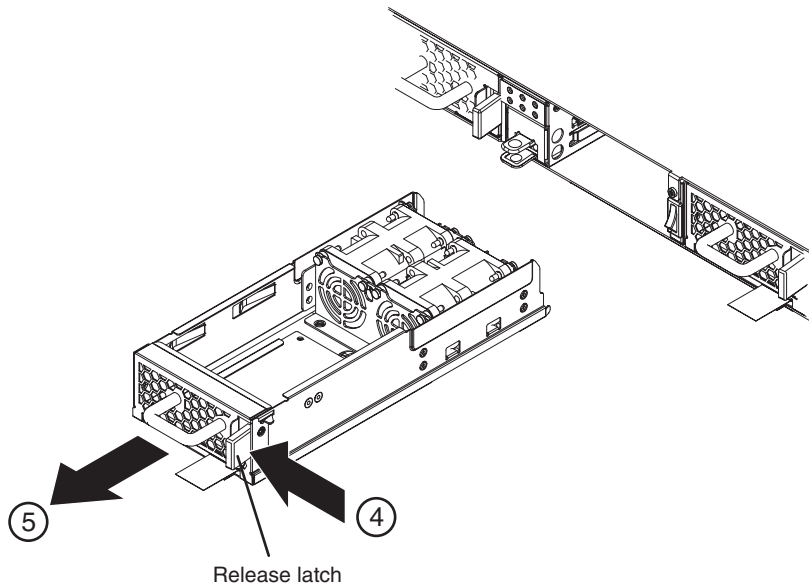

Figure 6. Removing the fan module

When removing the fan module, be careful not to damage the Service Card.

4. Press the blue release latch toward the handle, and hold the release latch in this position.
5. Pull the failed module from the back of the chassis.
6. When fully removed from the back of the chassis, set aside the failed module.
7. Unpack the replacement module.
8. Carefully align the replacement module, and insert into the chassis until you hear the release latch click in place.
9. Plug in all power cords.
10. Turn on the appliance by toggling the power switch to the ON position.

After replacing the fan module, you can verify that the new module is working if neither of the following LED lights are illuminated:

- The fan LED light on the rear of the chassis
- The error alarm LED light on the front of the chassis

After verifying that the replacement module is working, return the part to IBM. For details, refer to “Returning a appliance or component” on page 20.

Replacing a power supply module

You need to replace a power supply module when the following events occur:

- After the appliance generates a critical or warning message that indicates a power supply failure. The message identifies which power supply module to replace.
- When the following LED lights are illuminated:
 - The error alarm LED light on the front of the chassis is illuminated in yellow.

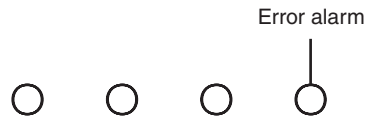

- One of the power supply LED lights on the rear of the chassis is illuminated in amber or is blinking in amber.

Best Practice: Replace a failed power supply module as soon as possible.

To replace a power supply module, use the following procedure:

1. Unplug the power cord of the failed module.
2. Firmly grip the handle of the failed module.

Figure 7 illustrates the following steps.

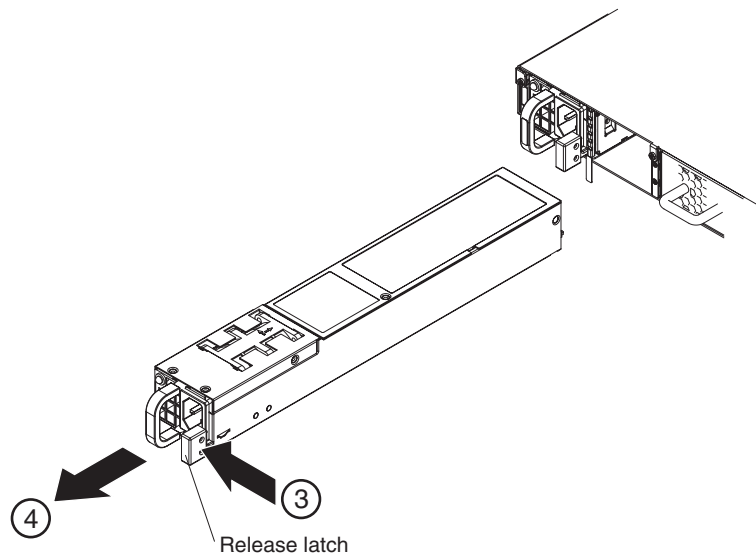

Figure 7. Removing a power supply module

3. Press the orange release latch toward the handle, and hold the release latch in this position.
4. Pull the failed module from the back of the chassis.
5. When fully removed from the back of the chassis, set aside the failed module.

Attention: Ensure that the gold connectors at the rear of the module do not come into contact with your hands or with the packing material as you unpack the replacement module.

Avoid damaging the gold connectors against the chassis as you insert the replacement module.

6. Unpack the replacement module.
7. Carefully align the replacement module, and insert into the chassis until you hear the release latch click in place.
8. Plug in the power cord to the replaced module.

After replacing the module, you can verify that the new module is working.

- The power supply module LED light on the rear of the chassis is illuminated in green.
- The error alarm LED light on the front of the chassis is not illuminated.

After verifying that the replacement module is working, return the part to IBM. For details, refer to “Returning a appliance or component” on page 20.

Replacing the hard disk drive module

You need to turn off the appliance and replace the hard disk drive module when the following events occur:

- After the appliance generates a critical message that indicates a fan failure in the hard disk drive module.
- When the following LED lights are illuminated:
 - The error alarm LED light on the front of the chassis is illuminated in yellow.

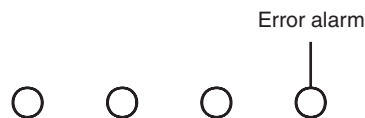

- The hard disk drive fan LED light on the rear of the chassis is illuminated in yellow.

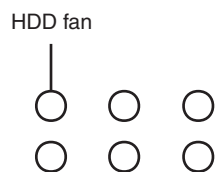

Best Practice: Turn off the appliance as soon as possible to avoid overheating. The remaining fans might not be able to maintain the appropriate environmental temperature.

To replace the hard disk drive module, use the following procedure:

1. If the appliance is not turned off, turn off the appliance by toggling the power switch to the OFF position. The power switch is on the rear of the chassis.
2. Unplug all power cords.
3. Firmly grip the handle of the failed module.

Figure 8 on page 27 illustrates the following steps.

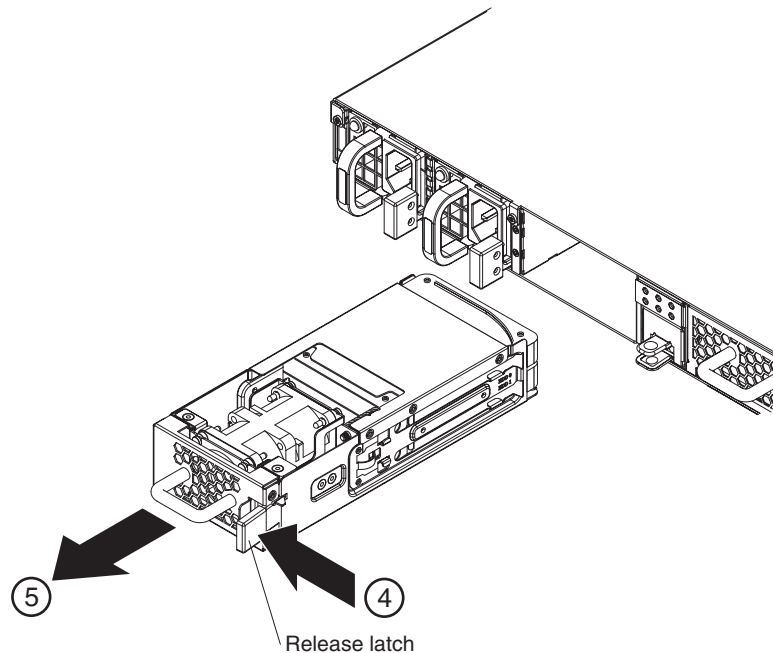

Figure 8. Removing the hard disk drive module

4. Press the blue release latch toward the handle, and hold the release latch in this position.
5. Pull the failed module from the back of the chassis.

Attention: Ensure that the gold connectors at the rear of the module do not come into contact with your hands or with the packing material as you unpack the replacement module.

Avoid damaging the gold connectors against the chassis as you insert the replacement module.

6. Remove the disks from the module.
 - a. Place the tips of your index fingers on the blue-tipped fastener tabs that hold the disks in the module. Each disk is held in the module by a fastener tab on the left- and right-side of the module.

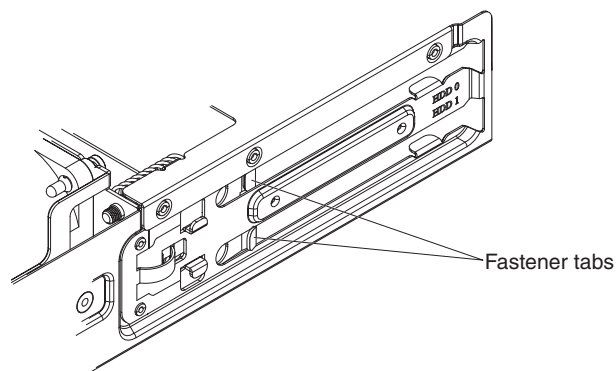

- b. Expand the fastener tabs slightly until the disk ejects from the module.
 - c. Remove the disk by its side edges.
7. Repeat step 6 to remove the other disk.
8. Set aside the failed module.

9. Unpack the replacement module.
10. Insert the original disks into the module:
 - a. Align the disk in the tray space.
 - b. Push the disk in until it locks in place.
11. Repeat step 10 to insert the other disk.

Attention: Avoid damaging the gold connectors against the chassis as you insert the module.

12. Carefully align the module, and insert it into the chassis until you hear the release latch click in place.
13. Plug in all power cords.
14. Turn on the appliance by toggling the power switch to the ON position.

After replacing the module, you can verify that the new module is working.

- The hard disk drive fan LED light on the rear of the chassis is not illuminated.
- The error alarm LED light on the front of the chassis is not illuminated.

After verifying that the replacement module is working, return the part to IBM. For details, refer to “Returning a appliance or component” on page 20.

Replacing individual disks

You need to turn off the appliance and replace an individual disk when the following events occur:

- After the appliance generates a critical message that indicates a disk failure. The message identifies which disk to replace.
- When the following LED lights are illuminated:
 - The error alarm LED light on the front of the chassis is illuminated in yellow.

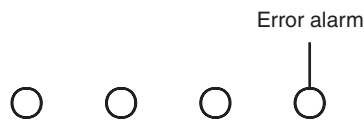

- A disk LED light on the rear of the chassis is illuminated in yellow. The illuminated LED light indicates which disk to replace.

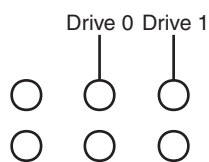

Drive 0 is the top disk, and Drive 1 is the bottom disk.

To replace an individual disk, use the following procedure:

1. If the appliance is not turned off, turn off the appliance by toggling the power switch to the OFF position. The power switch is on the rear of the chassis.
2. Unplug all power cords.
3. Firmly grip the handle of the hard disk drive module.

Figure 9 on page 29 illustrates the following steps.

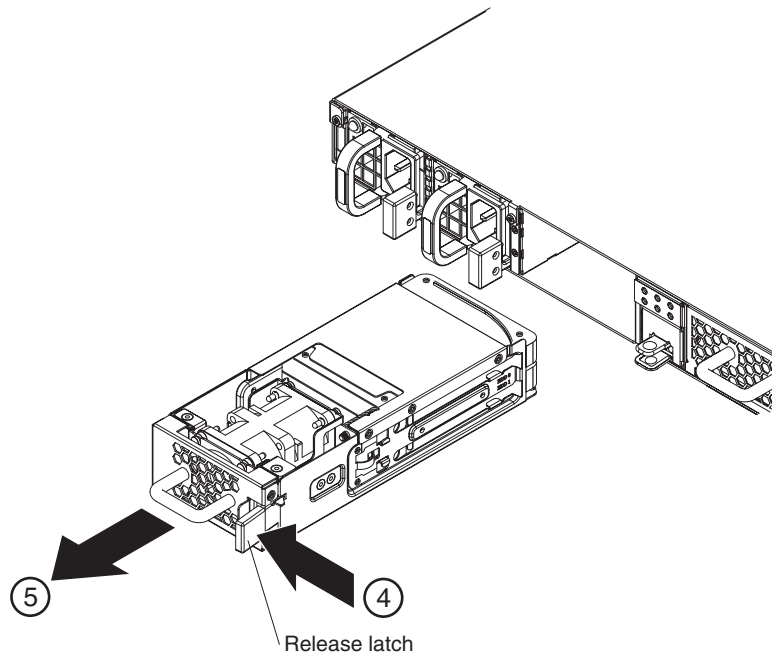
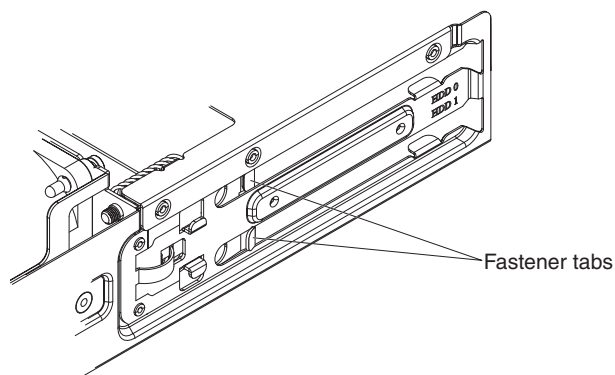

Figure 9. Removing the hard disk drive module

Attention: Ensure that the gold connectors at the rear of the module do not come into contact with your hands. Avoid damaging the gold connectors against the chassis as you remove the module.

4. Press the blue release latch toward the handle, and hold the release latch in this position.
5. Pull the module from the back of the chassis.
6. Remove the failed disk from the module.
 - a. Place the tips of your index fingers on the blue-tipped fastener tabs that hold the disk in the module. Each disk is held in the module by a fastener tab on the left- and right-side of the module.



- b. Expand the fastener tabs slightly until the failed disk ejects from the module.
 - c. Remove the disk by its side edges.
 - d. Set aside the failed disk.
7. Unpack the replacement disk.
8. Insert the new disk:
 - a. Align the new disk in the tray space.

- b. Push the disk in until it locks in place.

Attention: Avoid damaging the gold connectors against the chassis as you insert the module.

9. Carefully align the module, and insert into the appliance until you hear the release latch click in place.
10. Plug in all power cords.
11. Turn on the appliance by toggling the power switch to the ON position.

After inserting the module into the appliance, the error alarm LED light will be illuminated and the specific disk LED light will blink while the array is being rebuilt. When the array is finished being rebuilt, you can verify that the new disk is working.

- The disk LED light on the rear of the chassis is not illuminated.
- The error alarm LED light on the front of the chassis is not illuminated.

After verifying that the replacement module is working, return the part. For details, refer to “Returning a appliance or component” on page 20.

Removing and replacing consumable parts

Replacement of consumable parts is your responsibility. Use the following hardware maintenance procedures to remove and replace a consumable part:

- “Replacing the battery”

Consumable parts are not covered by the IBM Statement of Limited Warranty. For information about the terms of warranty, see the *IBM Statement of Limited Warranty* document on the *IBM WebSphere CloudBurst Appliance: Documentation*.

Replacing the battery

The battery cannot power the appliance. The appliance must be connected to active AC power sources for the appliance to process transactions. The battery maintains the following internal components only:

- The real time clock
- Static RAM-based memory, which contains various global parameters that include the current date and time for the appliance

Attention: Complete power failure (no AC power to the appliance with a missing or depleted battery) for seven days renders the appliance inoperable by activating the intrusion switch. After seven days, you might need to return the appliance to IBM to have the intrusion switch reset.

Leave the appliance connected to active AC power sources. Do not turn off the appliance when the battery needs to be replaced.

You need to replace the battery when the following events occur:

- After the firmware (battery age) or the hardware (battery capacity) generates a critical message that indicates battery failure.
- When the following LED lights are illuminated:
 - The error alarm LED light on the front of the chassis is illuminated in yellow.

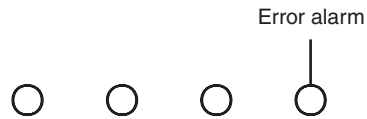

- The battery LED light on the rear of the chassis is illuminated in yellow.

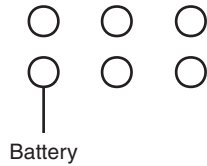

Note: The battery is considered to be a consumable item. It is not covered under the terms of the warranty. To obtain a replacement battery, order part number 44X0512. Refer to “Consumable parts listing” on page 22 for information about ordering this part.

The battery tray is not removable. The battery tray opens only far enough to allow you to replace the battery.

CAUTION:

The battery contains lithium. To avoid possible explosion, do not burn or charge the battery.

- Do not throw or immerse into water
- Do not heat to more than 100° C (212° F)
- Do not repair or disassemble

Exchange only with the IBM-approved part. Recycle or discard the battery as instructed by local regulations. In the United States, IBM has a process for the collection of this battery. For information, call 1-800-426-4333. Have the IBM part number for the battery unit available when you call. (C003)

To replace the battery, use the following procedure:

1. Leave the appliance connected to active AC power sources.
2. From the rear of the appliance, squeeze up on the tray latch of the battery tray, and slowly pull the battery tray approximately 3.5 in (8.9 cm) from the rear of the chassis.

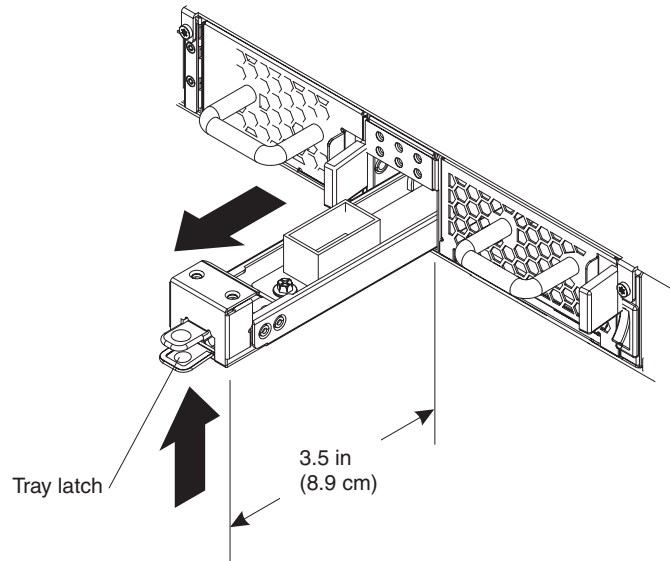

- When the battery tray is fully extended, remove the battery from its cradle by pulling up on the clear polyester tab that covers the battery.

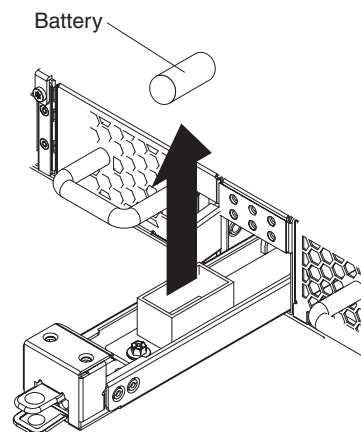

Note the positions of the negative pole and the positive pole on the battery with their corresponding marks on the inside of the battery cradle.

- Set aside the failed battery.
- Unpack the replacement battery.
- Align the negative pole and the positive pole of the replacement battery with their corresponding marks on the inside of the battery cradle.
- Insert the battery into the battery cradle until the battery snaps into place.
- Rotate the battery so that clear polyester tab does not catch against the opening (about 45° from vertical).
- Push the battery tray into the back of the chassis until you hear it click in place.

After replacing the battery, you can verify that the new battery is working. Neither of the following LED lights are illuminated:

- The battery LED light on the rear of the chassis
- The error alarm LED light on the front of the chassis

Dispose of the failed battery in accordance with the environmental policy of your country.

Removing and replacing the appliance from the rack

Best Practice: Two people should slide the appliance forward on the rails for removal. One person should pull from the front, and the other should push from rear.

Generally, after installing the appliance in the rack, you need to remove it only under the following conditions:

- To move it to another position in the rack
- To return it as a defective appliance to IBM

Note: Do not return an appliance to IBM unless explicitly instructed by a support representative.

Removing the RJ-45 cable

For appliances on which the locking tab for the ETH1 and ETH2 Ethernet interfaces faces upward, there is a release latch above the network connector. This latch, when gently pushed down, pushes down the locking tab on the connector so that the RJ-45 cable can be removed from the appliance. For appliances on which the locking tab faces downward, no release latch is present.

To remove a cable when a release latch is present, use the following procedure:

1. With one hand, hold the cable, and gently push it up a little.
2. With the other hand, gently push down the release latch to push down the locking tab on the cable.
3. With the hand that is holding the cable, gently pull out the cable.

Attention: Pushing down release tab too much might cause the release latch to deform.

Removing the appliance from the rack

CAUTION:

This part or unit is heavy but has a weight smaller than 18 kg (39.7 lb). Use care when lifting, removing, or installing this part or unit. (C008)

To remove the appliance from the rack, use the following procedure:

1. If the appliance is not turned off, turn off the appliance by toggling the power switch to the OFF position. The power switch is on the rear of the chassis.
2. Unplug all power cords.
3. Disconnect all cables.
4. Remove the right bracket from the appliance.

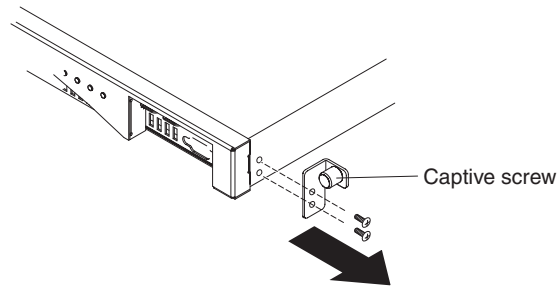

- a. Hand-loosen the captive screw on the bracket.
 - b. Use a screwdriver to remove the screws at the front right side of the chassis.
5. Repeat step 4 on page 33 to remove the left bracket from the appliance.
 6. Remove the appliance. Use care not to damage any release latches or handles at the rear of the appliance.

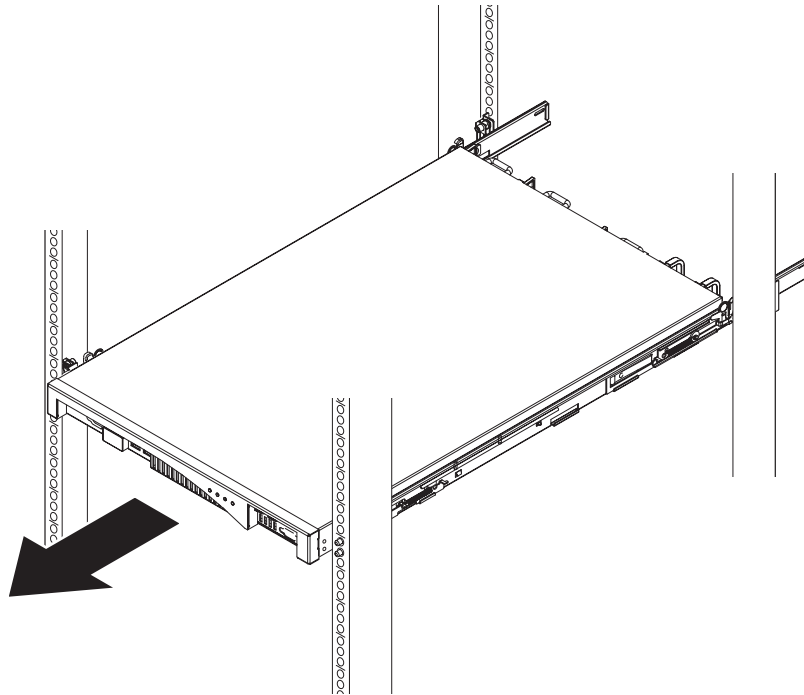

- a. Position one person at the front of the appliance, and position another person at the rear of the appliance.
- b. Each person grasps the appliance with thumb and finger.
- c. Slide the appliance along the rack rails. Both people need to work in concert.
 - The person at the front slowly pulls the appliance along the rack rails.
 - The person at the rear slowly pushes the appliance along the rack rails.
- d. Lift the appliance from its rails.

Replacing the appliance in the rack

The replacement WebSphere CloudBurst appliance includes all replaceable parts (CRU and consumable). These parts are included with the replacement appliance due to security agency requirements.

Note: You might be charged for missing parts if they are not returned with the defective appliance.

CAUTION:

This part or unit is heavy but has a weight smaller than 18 kg (39.7 lb). Use care when lifting, removing, or installing this part or unit. (C008)

To replace the appliance, use the following procedure:

1. Install the replacement appliance in the rack. For information, refer to the *IBM WebSphere CloudBurst Appliance: Installation Guide*.
2. Complete and secure the repair identification (RID) tag to the replacement appliance. For information, refer to “Applying the repair identification tag.”
3. Add the serial number of the original appliance to the system setting of the replacement appliance.
4. After verifying that the replacement appliance is working, securely package the defective appliance, with all parts, and return to IBM. For details, refer to “Returning a appliance or component” on page 20.

Applying the repair identification tag

When you receive a replacement appliance, the box contains a repair identification (RID) tag. The RID tag is important for transferring the serial number of the defective WebSphere CloudBurst appliance to the replacement appliance. The RID tag maintains the original serial number record of the appliance and allows IBM to entitle the appliance for future maintenance or warranty service. Replacement exchange requires the completion and securing of the RID tag to the replacement appliance.

When replacing your WebSphere CloudBurst appliance, use the following procedure:

1. Locate the defective appliance. The serial number of the defective appliance should match the serial number that you reported to IBM.
2. With a ballpoint pen, transcribe the machine type, model, and serial number of the defective appliance to the RID tag.
3. Secure the RID tag as close as possible, but not covering, the serial number of the replacement appliance. The original serial number of the replacement appliance must be visible.

Figure 10 on page 36 shows an example of the RID tag that is included in the box that contains the replacement appliance.

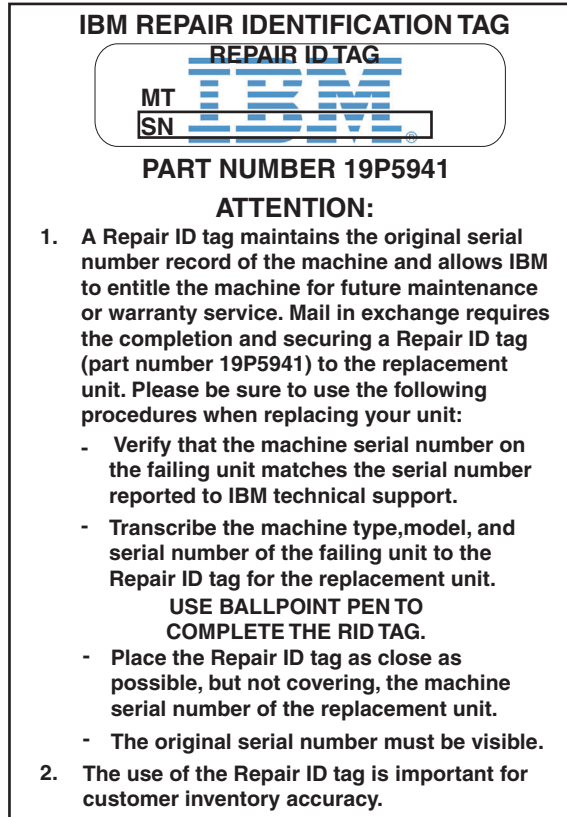

Figure 10. Example of the RID tag

Appendix. Getting help and technical assistance

This section describes the following options for obtaining support for IBM products:

- “Searching knowledge bases”
- “Receiving automatic updates”
- “Getting a fix” on page 38
- “Contacting IBM Support” on page 39

Searching knowledge bases

If you encounter a problem, you want it resolved quickly. You can search the available knowledge bases to determine whether the resolution to your problem was already encountered and is already documented.

Documentation

The IBM WebSphere CloudBurst Appliance documentation library provides documentation in an information center. You can use the search function to query information.

IBM Support

If you cannot find an answer in the documentation, use the *Search Support* feature from the product-specific support page.

From the **Search Support (this product)** area of the product-specific support page, you can search the following IBM resources:

- IBM technote database
- IBM downloads
- IBM Redbooks®
- IBM developerWorks®

Receiving automatic updates

You can receive automatic updates in the following ways:

- My support
- RSS feeds

Receiving updates through My support

To receive weekly e-mail notifications about fixes and other support news, use the following procedure:

1. Go to the IBM Support site at the following Web address:

<http://www.ibm.com/support>

2. Click **My support** in the upper-right corner under **Personalized support** to open the Sign in page.
3. If you have already registered for My support, sign in and skip to the next step.

If you have not registered, complete the following steps:

- a. Click **register now** in the upper right corner of the support page to establish your user ID and password.

- b. Complete the registration form by using your e-mail address as your IBM ID.
 - c. Click **Submit**.
4. Click the **Edit profile** tab.
5. For products about which you want to receive updates, use the filters to choose your exact interests:
 - a. Click **Add products**
 - b. From the first list, select the product category; for example, **Software**
 - c. From the second list, select the product segment; for example, **Business Integration**
 - d. From the third list, select the next segment of the product; for example, **Application Integration and Connectivity**
 - e. From the list of displayed products, select all products for which you want to receive updates; for example **WebSphere CloudBurst**
 - f. Click **Add products**
6. Click **Subscribe to e-mail**.
7. Select the types of e-mail to receive:
 - a. From the list, select **Software**
 - b. Select **Please send these document by weekly e-mail**
 - c. To define a different e-mail address, click **Edit**
 - d. From the list of documents, select the one of interest
 - e. Click **Update**

Receiving updates through RSS feeds

For information about RSS, including steps for getting started and a list of RSS-enabled IBM Web pages, visit the following Web site:

<http://www.ibm.com/software/support/rss>

Getting a fix

A product fix might be available to resolve your problem. To determine what fixes are available for your IBM product, and to download updates, navigate to one of following Web addresses:

The IBM WebSphere CloudBurst Appliance support page

<http://www-01.ibm.com/software/webservers/cloudburst/support/>

You can search for information on this site or click any of the links to obtain a download or search available documentation.

Fix central

<http://www.ibm.com/support/fixcentral/>

1. From the **Product Group** drop down list, select .
2. From the **Product** drop down list, select **WebSphere CloudBurst Appliance**.
3. From the **Installed version** drop down list either select the version of WebSphere CloudBurst that you are using or select **all** to see available updates for all versions.
4. Leave **All** as the default setting in the **Platform** drop down list.
5. Click **Continue**.

6. Sign in providing your **IBM ID** and **Password**.
7. Click **Continue**.
8. You can then browse for information about fixes in a variety of ways (including by recommendation, keyword, or APAR number) to find a fix.

Contacting IBM Support

IBM Support provides assistance with product defects. Before contacting IBM Support, the following criteria must be met:

- Your company has an active maintenance contract.
- You are authorized to submit problems.

To contact IBM Support with a problem, use the following procedure:

1. Define the problem, gather background information, and determine the severity of the problem. For help, refer to the *Software Support Handbook*. To access the online version of this handbook, use the following procedure:
 - a. Access the IBM Software Support Web page at the following Web address:

<http://www.ibm.com/software/support>

- b. From the **Overview** section on the right of the page, click the **Support handbook** link.
 - c. Bookmark this page for future reference.
- From this page, you can obtain a PDF copy of the handbook.
2. Gather diagnostic information.
 - a. Access product support at the following Web address:

http://www.ibm.com/support/entry/portal/Open_service_request/Software/WebSphere/WebSphere_CloudBurst_Appliance

- b. Locate the **Before submitting a request** area of the product support page.
 - c. Click **MustGather: Read first for IBM WebSphere CloudBurst Appliance** to access that technote that lists the information that is required to report a problem.
3. Submit the problem in one of the following ways:

Online

- a. Navigate to the IBM Support Web site (<http://www.ibm.com/support>).
- b. Locate the **Electronic services** section of the page.
- c. Click **Open a service request** and follow the instructions.

By phone

For the phone number to call in your country, refer to “Contacts” in the *Software Support Handbook*. From the Software Support Handbook Web site, click **Contacts**. In the U.S. and Canada, call 1-800-IBM-SERV (1-800-426-7378) and select option 2 for software.

If the problem you submit is for a software defect or for missing or inaccurate documentation, IBM Support creates an authorized program analysis report (APAR). The APAR describes the problem in detail. Whenever possible, IBM Support provides a workaround that you can implement until the APAR is resolved and a fix is delivered.

Notices

This information was developed for products and services offered in the U.S.A.

IBM may not offer the products, services, or features discussed in this document in other countries. Consult your local IBM representative for information about the products and services currently available in your area. Any reference to an IBM product, program, or service is not intended to state or imply that only that IBM product, program, or service may be used. Any functionally equivalent product, program, or service that does not infringe any IBM intellectual property right may be used instead. However, it is the user's responsibility to evaluate and verify the operation of any non-IBM product, program, or service.

IBM may have patents or pending patent applications covering subject matter described in this document. The furnishing of this document does not grant you any license to these patents. You can send license inquiries, in writing, to:

IBM Director of Licensing
IBM Corporation
North Castle Drive
Armonk, NY 10504-1785
U.S.A.

The following paragraph does not apply to the United Kingdom or any other country where such provisions are inconsistent with local law: INTERNATIONAL BUSINESS MACHINES CORPORATION PROVIDES THIS PUBLICATION "AS IS" WITHOUT WARRANTY OF ANY KIND, EITHER EXPRESS OR IMPLIED, INCLUDING, BUT NOT LIMITED TO, THE IMPLIED WARRANTIES OF NON-INFRINGEMENT, MERCHANTABILITY OR FITNESS FOR A PARTICULAR PURPOSE. Some states do not allow disclaimer of express or implied warranties in certain transactions, therefore, this statement may not apply to you.

This information could include technical inaccuracies or typographical errors. Changes are periodically made to the information herein; these changes will be incorporated in new editions of the publication. IBM may make improvements or changes in the product(s) or the program(s) described in this publication at any time without notice.

Important notes

This product is not intended to be connected directly or indirectly by any means whatsoever to interfaces of public telecommunications networks nor is it intended to be used in a public services network.

Electronic emission notices

Federal Communications Commission (FCC) statement

Note: This equipment has been tested and found to comply with the limits for a Class A digital device, pursuant to Part 15 of the FCC Rules. These limits are designed to provide reasonable protection against harmful interference when the equipment is operated in a commercial environment. This equipment generates, uses, and can radiate radio frequency energy and, if not installed and used in

accordance with the instruction manual, may cause harmful interference to radio communications. Operation of this equipment in a residential area is likely to cause harmful interference, in which case the user will be required to correct the interference at his own expense.

Properly shielded and grounded cables and connectors must be used in order to meet FCC emission limits. IBM is not responsible for any radio or television interference caused by using other than recommended cables and connectors or by unauthorized changes or modifications to this equipment. Unauthorized changes or modifications could void the user's authority to operate the equipment.

This device complies with Part 15 of the FCC rules. Operation is subject to the following two conditions: (1) this device may not cause harmful interference, and (2) this device must accept any interference received, including interference that may cause undesired operation.

Industry Canada Compliance Statement

This Class A digital apparatus complies with Canadian ICES-003.

Avis de conformité à la réglementation d'Industrie Canada

Cet appareil numérique de la classe A est conforme à la norme NMB-003 du Canada.

United Kingdom telecommunications safety requirement

Notice to Customers: This apparatus is approved under approval number NS/G/1234/J/100003 for indirect connection to public telecommunication systems in the United Kingdom.

European Union EMC Directive conformance statement

This product is in conformity with the protection requirements of EU Council Directive 2004/108/EC on the approximation of the laws of the Member States relating to electromagnetic compatibility. IBM cannot accept responsibility for any failure to satisfy the protection requirements resulting from a non-recommended modification of the product, including the fitting of non-IBM option cards.

This product has been tested and found to comply with the limits for Class A Information Technology Equipment according to CISPR 22/European Standard EN 55022. The limits for Class A equipment were derived for commercial and industrial environments to provide reasonable protection against interference with licensed communication equipment.

Attention: This is a Class A product. In a domestic environment this product may cause radio interference in which case the user may be required to take adequate measures.

European Community contact:

IBM Technical Regulations
Pascalstr. 100, Stuttgart, Germany 70569
Telephone: 0049 (0)711 785 1176
Fax: 0049 (0)711 785 1283
Email: tjahn@de.ibm.com

Japanese Voluntary Control Council for Interference (VCCI) statement

この装置は、情報処理装置等電波障害自主規制協議会（VCCI）の基準に基づくクラスA情報技術装置です。この装置を家庭環境で使用すると電波妨害を引き起こすことがあります。この場合には使用者が適切な対策を講ずるよう要求されることがあります。

The following is a summary of the VCCI Japanese statement in the box above.

This is a Class A product based on the standard of the Voluntary Control Council for Interference by Information Technology Equipment (VCCI). If this equipment is used in a domestic environment, radio disturbance may arise. When such trouble occurs, the user may be required to take corrective actions.

Taiwanese Class A warning statement

警告使用者：
這是甲類的資訊產品，在居住的環境中使用時，可能會造成射頻干擾，在這種情況下，使用者會被要求採取某些適當的對策。

Chinese Class A warning statement

声 明
此为 A 级产品。在生活环境中，该产品可能会造成无线电干扰。在这种情况下，可能需要用户对其干扰采取切实可行的措施。

Korean Class A warning statement

이 기기는 업무용으로 전자파적합등록을 한 기기이오니 판매자 또는 사용자는 이점을 주의하시기 바라며, 만약 잘못 판매 또는 구입하였을 때에는 가정용으로 교환하시기 바랍니다.

Russian Class A warning statement

ВНИМАНИЕ! Настоящее изделие относится к классу А.
В жилых помещениях оно может создавать
радиопомехи, для снижения которых необходимы
дополнительные меры

Trademarks

IBM, the IBM logo, ibm.com, and WebSphere are trademarks or registered trademarks of International Business Machines Corporation in the United States, other countries, or both. If these and other IBM trademarked terms are marked on their first occurrence in this information with a trademark symbol (® or ™), these symbols indicate U.S. registered or common law trademarks owned by IBM at the time this information was published. Such trademarks may also be registered or common law trademarks in other countries. A current list of IBM trademarks is available on the Web at "Copyright and trademark information" at www.ibm.com/legal/copytrade.shtml

IBM, the IBM (logo), CloudBurst, developerWorks, DirMaint, DS4000, Passport Advantage, PowerVM, Redbooks, System Storage, WebSphere, and z/VM are registered trademarks of the International Business Machines Corporation in the United States or other countries.

Adobe is either a registered trademark or trademark of Adobe Systems Incorporated in the United States, and/or other countries.

Linux is a registered trademark of Linus Torvalds in the United States, other countries, or both.

Microsoft and Windows are trademarks of Microsoft Corporation in the United States, other countries, or both.

Other company, product, and service names may be trademarks or service marks of others.



Part Number: 81Y6188

Printed in USA

(1P) P/N: 81Y6188

