

IBM Information Agenda - 2010

New Intelligence for a Smarter Planet

Mike Biere, Sr. Marketing Manager
IBM Silicon Valley Lab
mbiere@us.ibm.com

Session Number: 001





System z: The platform for the future

"you cannot think seriously about your longer-term IT architecture without thinking equally seriously about what today's mainframe environment has to offer"



CIO Magazine: Mainframe computing is set for a rebirth – September 29, 2009



The Information Challenge...

52% of users
don't have confidence
in their information



42% of managers
use wrong information
at least once a week

**Leveraging Information
for Smarter Business Outcomes**

**Core & Other
Operational Systems**

Organizations are Increasingly Focused on Leveraging Information for Smarter Business Outcomes

2X

Client Investment in Business Optimization Projects is Growing over Twice as Fast as Business Automation

Business Automation
\$566B
3% CGR

Business Optimization and Analytics
\$105B
8% CGR

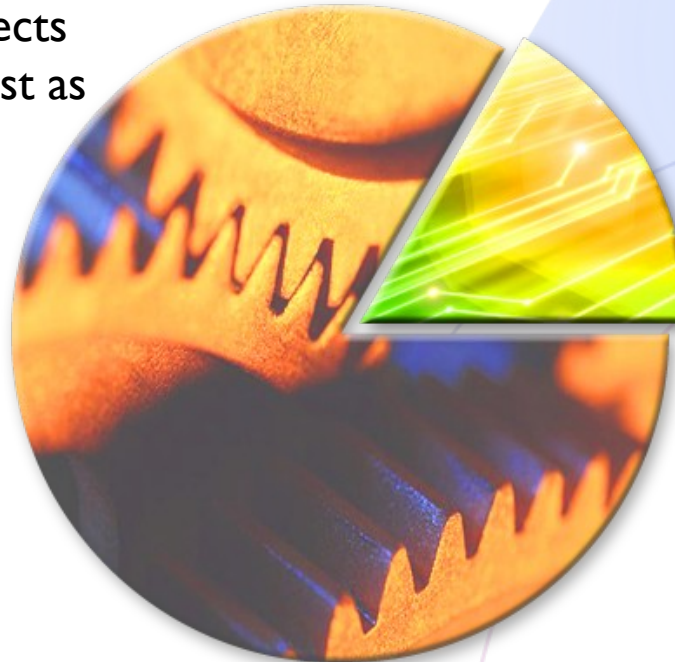

IT Spending Estimates, 2009*

* Includes Hardware, Software and Services. Does not include Networking, Printer, or Standalone Printer or PC Markets. CGRs 2009–2012.

Opportunity estimates based on analysis done by the IBM Market Intelligence Department. IBM Market Intelligence data is provided for illustrative purposes and is not intended to be a guarantee of market opportunity.

Information Must Be Trusted, Pervasive and Increasingly Predictive & Immediate to Lead Business Transformation



Retail

“... Are our price points below or above those of key competitors, and by how much?”

“...If below, is this sustainable given our cost profile, or is cost a future threat?”

“...What premium will customers pay for value-added propositions?”

“...what offer can I make to this customer right now to best increase profitability?”



Banking

“...What is my risk this morning and how have the credit limit changes been impacted my closing rates?”

“...Do we suspect any SEC violations?”

“...can I safely approve this transaction right now with low risk?”



Government

“...Which programs should continue to get our stimulus funding, what is their status and how effective the funds being used?”

“...Which funds are being used outside the bounds of the original proposal?”



Healthcare

“...What emerging treatment may relate to this patient?”

“...Which treatments are ineffective and should be eliminated to help lower costs?”

“...Do any of my patients need attention right now to avoid a potential problem?”



Industrial

“...What can we do to minimize warranty claims?”

“...Do we have product issues or are there fraudulent claims coming in from our northeast service centers?”

“...Do we have any regulatory exposures and now? what safety risks might be related?”



Communications

“...How and when should I adjust my global offering prices to reduce churn in my existing market and expand share in an emerging market?”

“Is my network at risk of failure that can be avoided if I take protective action right now?”





Getting started with an information-led transformation

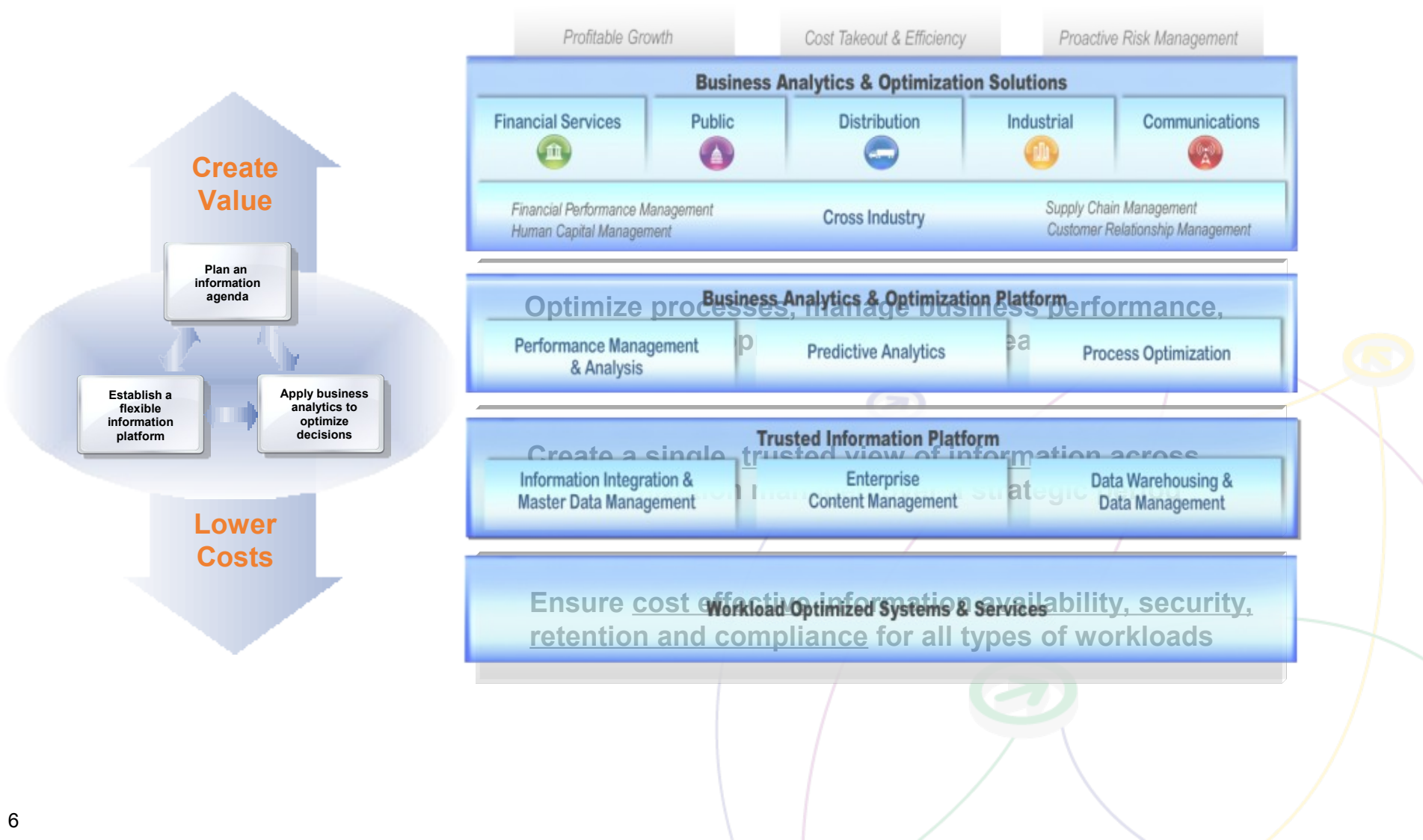



Leveraging System z for Information On Demand

More new capabilities delivered in the past 3 years than at any point in the mainframe's history

SPSS & Guardium
and much more coming . . .

**End-to-end
Capabilities
on System z**

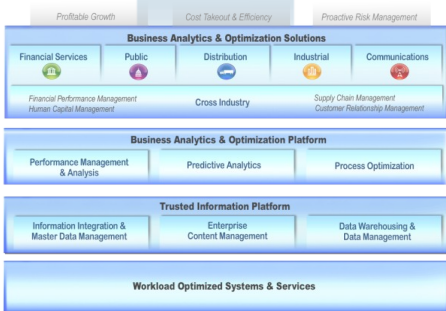

IMS 11

Open Access

InfoSphere Warehouse for System z

2009

InfoSphere Global Name Recognition for System z

DW Tools

FileNet Content Manager for System z

Cognos 8 BI for System z

Business Intelligence

Data Studio pureQuery for System z

Info Agenda Launch

InfoSphere MDM Server for System z

App Dev Tools

Optim Data Governance for System z

2008

Information Server for System z

Data Archiving
Test Data Mgmt

Content Manager 8.4

Data Warehousing

DB2 9 IMS 10
for z/OS

ETL & Data Quality

2007

**IOD
Launch
2006**

SOA

pureXML

DB2.
software

InfoSphere™
software

Cognos.
software

FileNet.
software





Managing the data



IMS

→ IMS 10 encourages business growth while still keeping cost in check.

Many companies are searching for ways to increase the flexibility and reuse of their existing IT assets.

→ IMS 11 is designed to drive efficiency and lower costs while simplifying administration and enabling greater business flexibility

- IMS Open Database support allows any application on any platform to access IMS data directly and transparently
- Enhanced application development tooling allows easier application development and modernization
- Autonomic computing capabilities relieve skill constraints
- Raising the performance bar again - extreme performance with greater than 22,000 transactions/second

Analysts Agree!



“As IMS continues to evolve, it should be able to maintain a strong claim on the highly complex data management and high throughput workloads that it has historically served so well.” *Carl Olofson, IDC*



Interesting Facts about DB2 for z/OS



→ **Used by...**

- The top 59 banks in the world
- 23 of the top 25 US retailers
- 9 of the top 10 global life/health insurance providers

→ **Performance, Performance, Performance**

- Delivered the largest banking benchmark ever at the Bank of China, a record 9,445 transactions per second
- 15,000 Transactions per second, almost 300,000 SQL/sec for large Asian bank benchmark.
- Supports the world's largest known peak database workload - 1.1 Billion SQL statements per hour at UPS
- The world's largest known transaction processing database – 23.1 TB at UK Land Registry

→ **Availability, security, advanced virtualization**

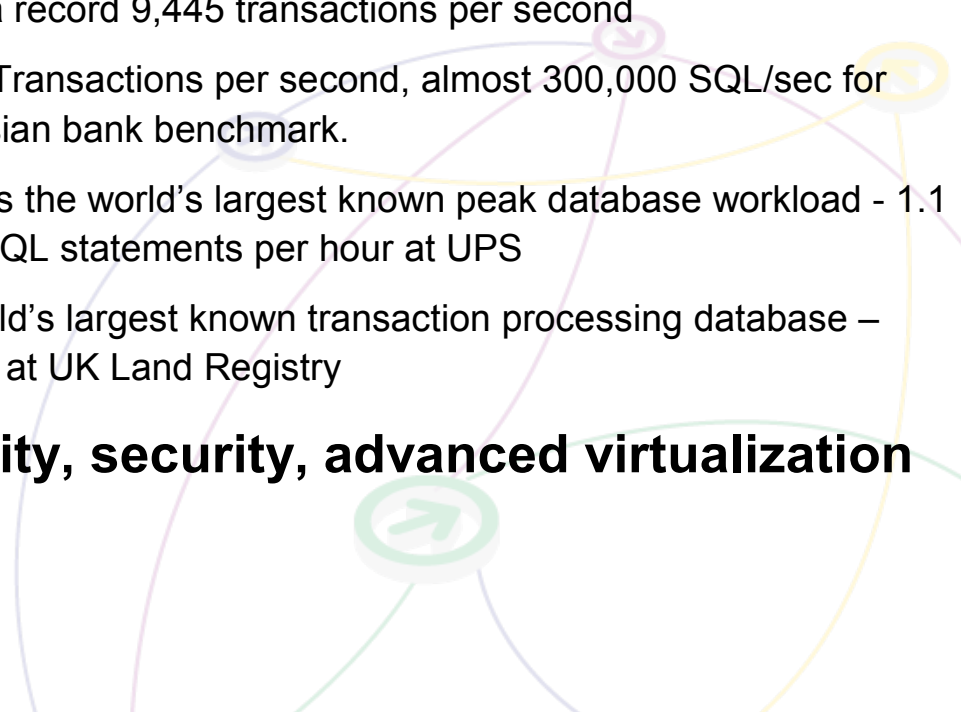



DB2 and IMS Solutions that manage the value of your data throughout its lifetime

InfoSphere Data Architect

Optim Data Growth Solution
DB2 Performance Mgt Solution
IMS Performance Mgt Solution

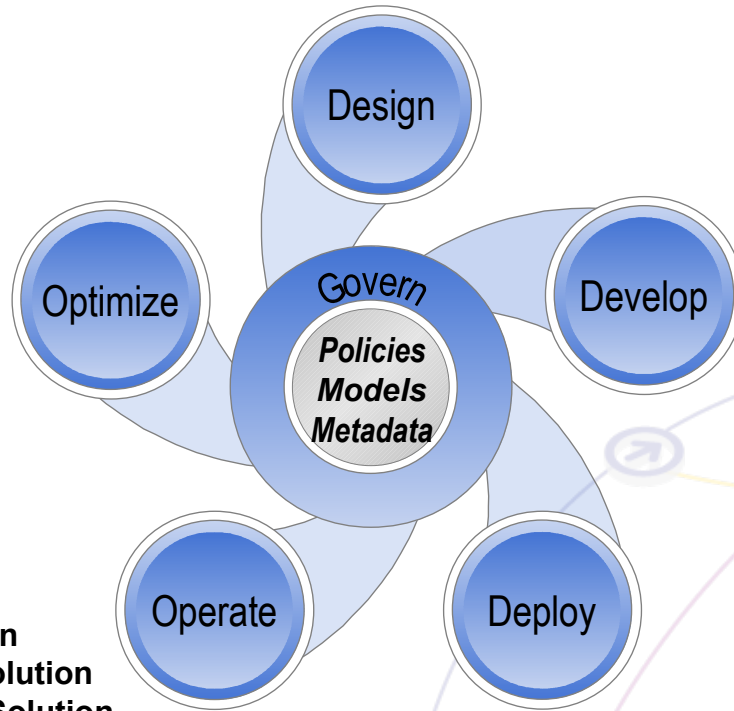

Optim Development Studio
Optim Test Data Management
Optim Data Privacy Solution

DB2/IMS Administration Solution
DB2/IMS Backup & Recovery Solution
DB2/IMS Utilities Management Solution
IMS Transaction Management Solution

Optim Development Studio
Optim pureQuery Runtime
DB2/IMS Application Mgt Solution

DB2/IMS Data Governance Solution



A Customer Success Story – Migration to IBM DB2 and IMS Tools

Challenges

- ❑ Largest savings bank in Spain.
- ❑ Needed to lower mainframe software costs
- ❑ Operated a complex z/OS environment, managing more than 20TB of IBM DB2 software data and more than 30TB of data hosted on IBM IMS software databases.
- ❑ “No impact in production” policy

la Caixa turned to IBM to provide more cost-effective tools for this system

Solutions

- ❑ IBM DB2 Tools: DB2 Administration Tool, DB2 Automation Tool, DB2 Query Monitor, DB2 SQL Performance Analyzer, DB2 Utilities Suite, DB2 High Performance Unload, DB2 Change Accumulation
- ❑ IBM IMS Tools: IMS HP Fast Path Utilities, IMS HP Change Accumulation, IMS Index Builder, IMS DEDB Fast Recovery, IMS Database Recovery Facility, IMS HP Image Copy

Benefits

- ❑ No disruption to business during and after migration
- ❑ Experienced easier contract agreement
- ❑ Products that keep pace with IMS & DB2 development
- ❑ Can exploit new IMS and DB2 functions in the IBM tools

**“Strong proactive approach
from IBM labs” – la Caixa**



Managing Content





ECM Market Drivers/State of the Industry: 2009

2008

1. Cost savings: 44%
2. Compliance: 39%

2009
1. Cost savings: 50%

2. Compliance: 34%



“Cost saving has taken a clear lead over compliance as the main business driver for investments in document and records management.” — AIIM

Other survey results

- 56% of organizations still have little or no confidence that important emails are recorded, complete and recoverable (62% in 2008). 27% consider email attachments “very unmanaged”
- 28% of organizations would take more than a month to produce documents for a legal discovery process
- 34% planned to migrate to a single ECM system

AIIM State of the Industry Survey, March 2009

IBM ECM Product Vision

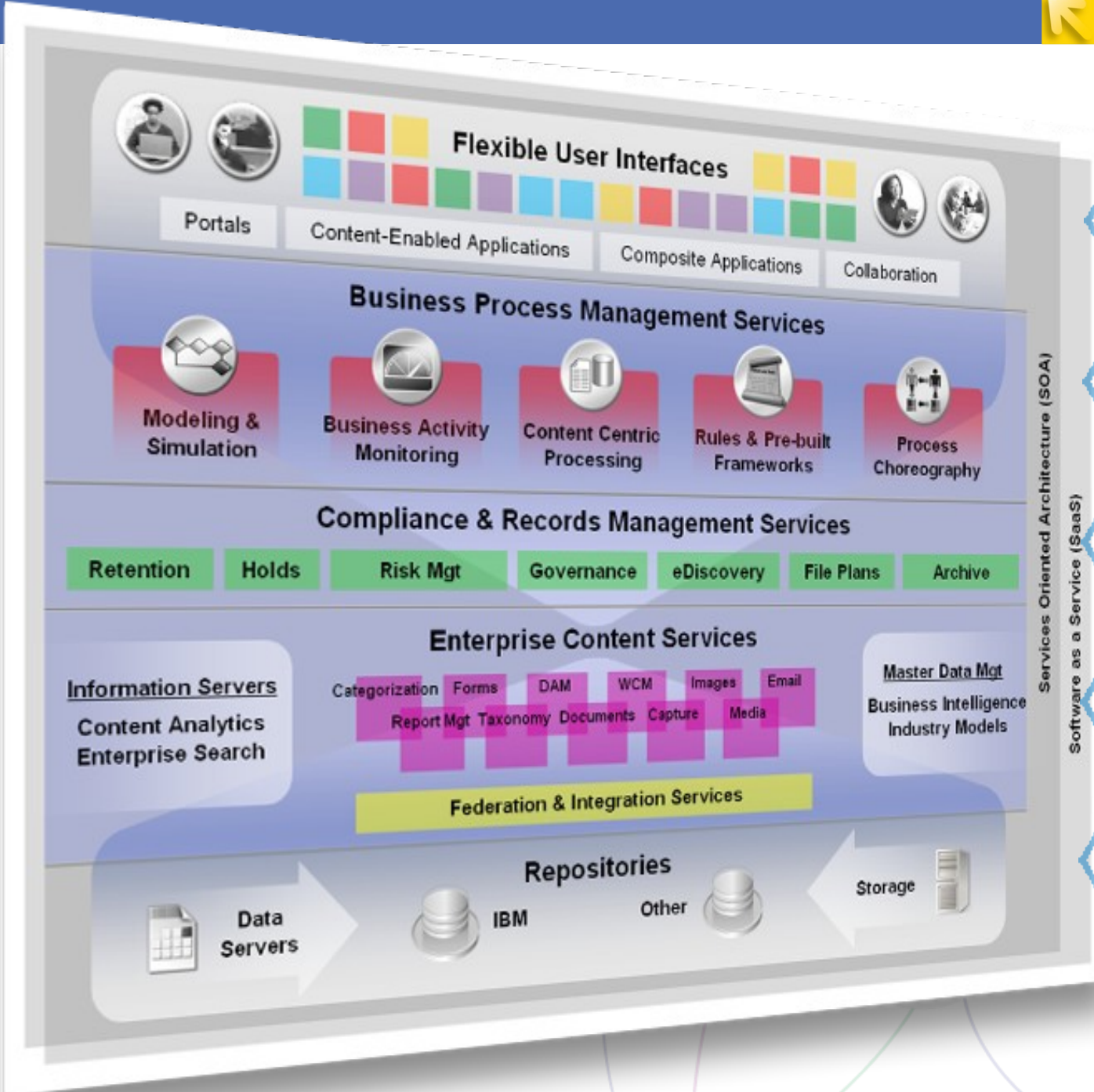

Pervasive
Persuasive

Business
Agility

Enterprise
Compliance

Active
Content

Content
Anywhere



ECM Products on System z

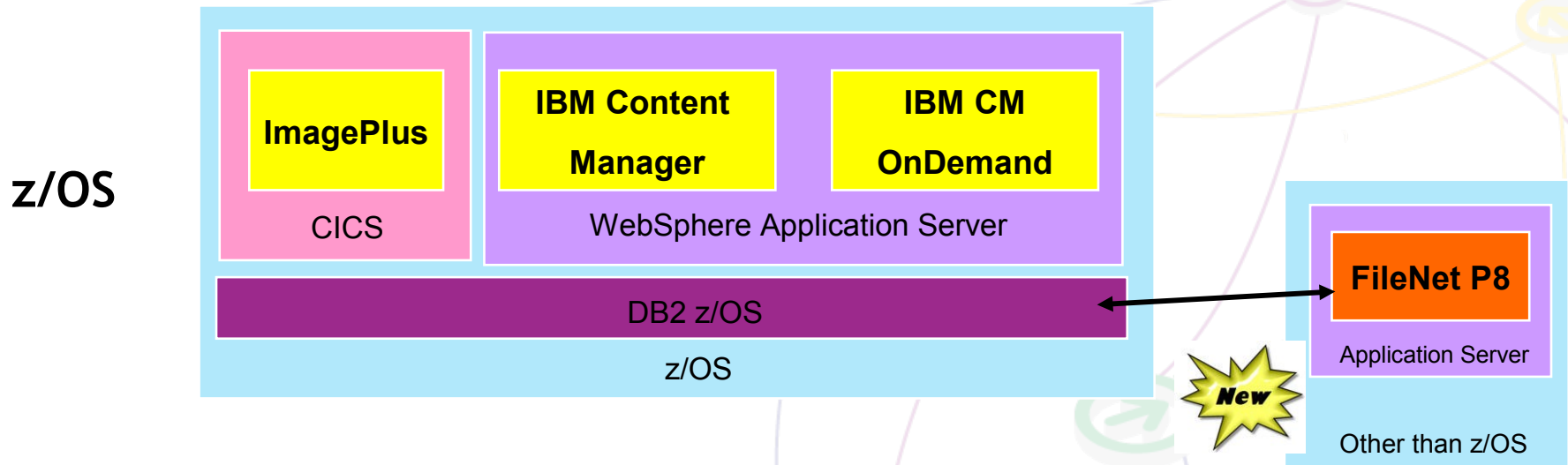
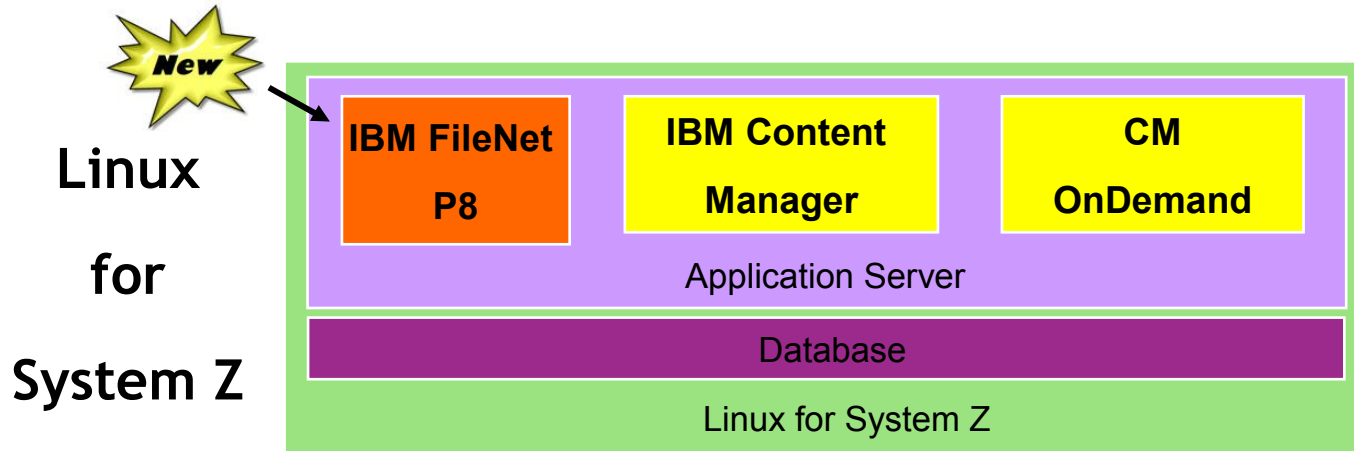



The Value of ECM on System z

- Excels at “mission critical” applications
- Delivers new business capability faster
- Offers higher security and control
- Drives economies of scale and reduces TCO of solution
- Ball State University - deployed on System z to harness the reliability, scalability, versatility, and power of the System z platform while reducing their energy consumption in an overall “greening” effort
- Primerica Financial - deployed on System z because they believe it is the best platform to achieve the availability and scalability they need, that it facilitates disaster/recovery and information security administration, and that it provides the best overall total cost of ownership.
- Health Care Service Corporation – deployed ECM on System z to extend their existing infrastructure, skills and disaster recovery solution to their ECM applications and is deploying next applications on Content Manager (z/OS) using Web services



Control of the Information





Managing your business environment

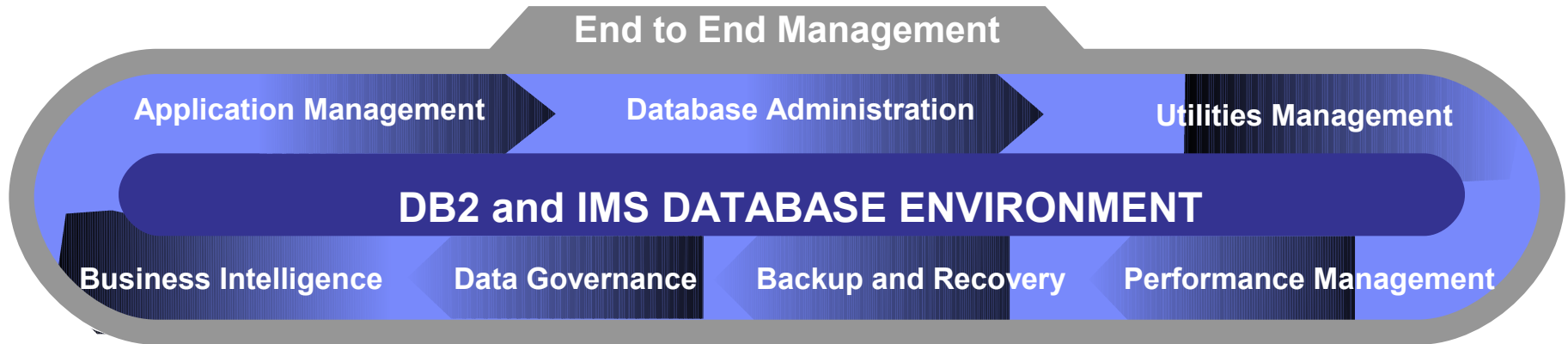

Business Challenges

- Optimizing costs associated with maintaining existing applications
- Quickly responding to new business requirements and opportunities
- Ensuring that business and regulatory needs can be properly met
- Maximizing IT staff productivity to streamline business operations



Enterprise Data Governance

- Data breaches, corporate mistakes, use of bad data continue to make headline news
- Every organization is concerned with regulatory compliance, security, privacy, data quality. Bad data is bad for business.
- IBM created three entry points that enable customers to address their more pressing needs while embracing other aspects of data governance as and when required :
 - *Information Quality – understand, analyze, cleanse, transform, deliver*
 - *Lifecycle Management – collect, store, process, optimize, manage, report, retain*
 - *Information Protection – security, privacy, audit, logging, reporting*

Accenture survey 75 percent of CEOs want to better manage and use their information ,78 percent believe they can achieve better competitive advantage, only 15 percent are comprehensively managing their data.

Data Governance is fundamental to successful BI and DW projects.

Enterprise Data Governance for System z

- Archive inactive data
lower storage cost

Optim Data Growth Solution

- Comply with internal and external auditing requirements

DB2 / IMS Audit Mgt. Expert
Tivoli Compliance Insight Manager

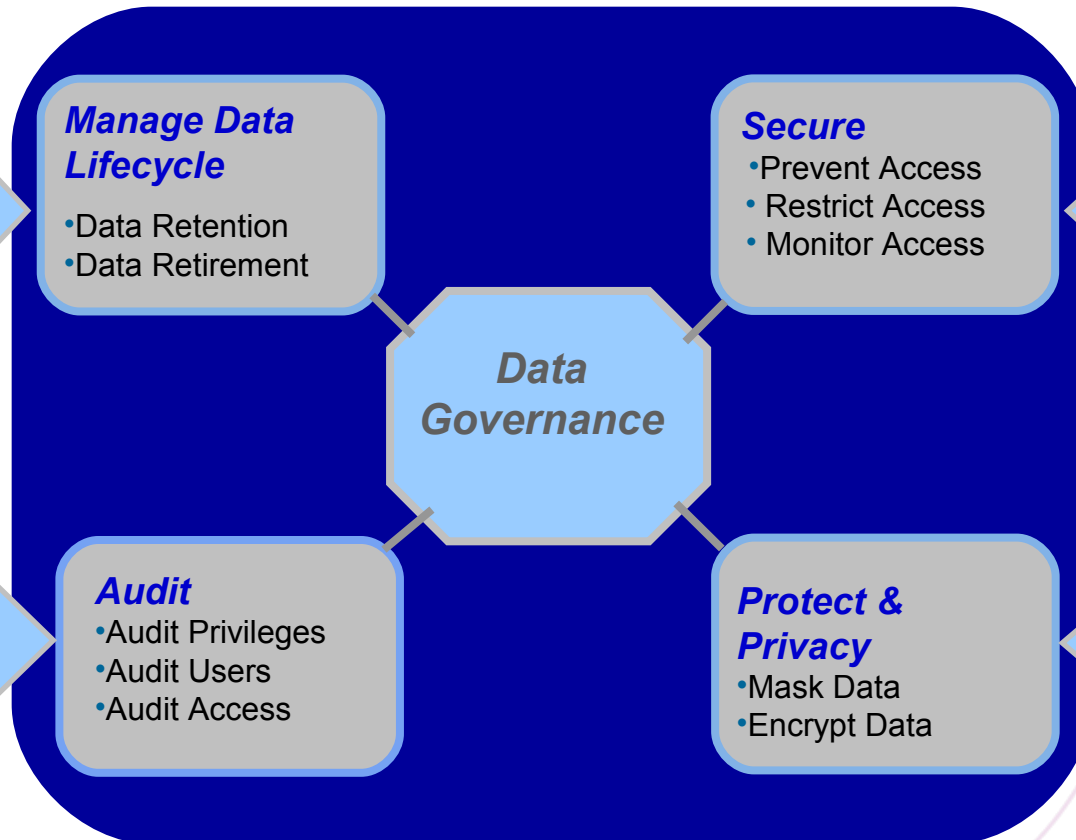

- Reduce risk from Security breaches

DB2/RACF Security
Tivoli zSecure Suite

- Protect sensitive customer and employee data

Data Encryption for IMS and DB2
Optim Test and Optim Data Privacy

IBM is the only solution provider with an end to end comprehensive solution



Data Warehousing and Business Intelligence





The Resurgence of Data Warehousing and Business Intelligence on System z

→ IBM has invested hundreds of millions of dollars to bring new state of the art capabilities and solutions to System z in support of customers' warehouse and BI requirements

- A 2007 study by IDUG found that nearly 50% of IDUG respondents are already using DB2 for z/OS for data warehousing. 78% indicated a desire for more capabilities in warehousing, query and reporting.



- *Analysts Agree!* IBM's Data Warehousing & BI breadth on System z is a game changer in the market.
Donald Feinberg, Gartner



Mission Critical Workloads Require Highest QoS

- **More than 90%** of Global 2000 companies plan to incorporate analytics into multiple operational applications that access the data warehouse by 2010, but fewer than 15% of data warehouses have been designed to provide high availability, failover, disaster recovery and the remaining components of mission-critical systems.
- By the end of 2009, **90% of Global 2000** companies will have implemented some type of mission-critical dependency between the warehouse and at least one revenue supporting or cost-controlling operational application — up from less than 25% in 2007.
- **Fewer than 15% of data warehouses** in 2007 have been designed to provide high availability, failover, disaster recovery and the remaining components of mission-critical systems.

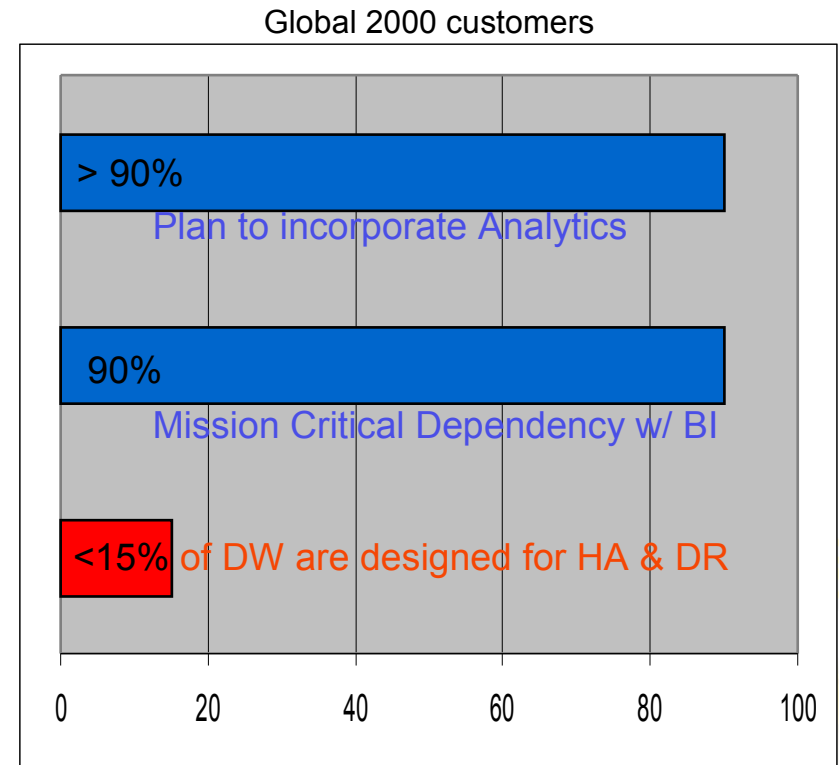

- Sounds like a good match for System z value proposition
 - Proven reliability and continuous availability capabilities
 - Exploiting synergistic effects of proximity to the operational data

¹ Operational Analytics and the Emerging Mission-Critical Data Warehouse, 14 May 2007



Why are customers moving to the strengths of System z for Data Warehousing and Business Intelligence?

Many System z customers already use System z for warehouse and BI

IBM is responding to customer demand with new DB2 features, new software offerings and improved hardware performance and efficiency.

Customers want to leverage their existing System z infrastructure

Costs can be reduced through the utilization of existing processors, people, Practices.

Cost savings may also be achieved through a consolidation approach.

New BI trends map well to the strengths of DB2 for z/OS and System z

Distinction is blurring between warehouse and OLTP databases due to new trends like Dynamic Warehouse and Operational BI, driving the need for:

- Increased reliability, availability, security, and compliance in a DWH
- Very current warehouse data and/or collocation of warehouse and operational data

Specialty processors and the new z10 provide additional ways to optimize TCO

zIIPs and IFLs are driving down hardware and software costs; DWH/BI can make excellent use of these processors, ultimately driving TCO advantages.

The new processors are delivering excellent speeds and feeds, making CPU horsepower less of an Issue.



Data Warehousing on system z – IBM at your service

- **Whitepaper** : Why Data Warehousing on System z available in the WEB
<http://www-306.ibm.com/software/data/db2bi/systemz.html>
- DW on system z – **Demo** available in the Technical Marketing Competence Center, Böblingen, Germany, TMCC@de.ibm.com
- DW on system z – **Customer Briefings** in the Executive Briefing Center at SVL or the Technical Marketing Competence Center, Böblingen, Germany
- DW on system z – **‘Redbook’** available





Data Integration



InfoSphere Information Server for System z

Accelerating the delivery of trusted information

**Profile, cleanse, and transform information
from heterogeneous data sources
to drive greater business insight**



IBM Information Server Unified Deployment



Unified Metadata Management

- Significant cost savings on System z
- Scalable to any volume and processing requirements
- Fully integrated, auditable data quality
- Metadata-driven integration for increased productivity

InfoSphere MDM Server for System z

The first multi-domain, multi-function MDM product in the market

→ Packaged to address all types of MDM implementations

- From small “registry” projects to strategic “transaction-hub” deployments
- Allows clients to grow as required by implementing existing functionality
- Significantly lowers client risk and time/cost to implement

→ Enables a SOA Library

- 800 pre-packaged business services
- Significant out of the box functionality
- Reduces total cost of ownership

→ Provides leading performance & scalability

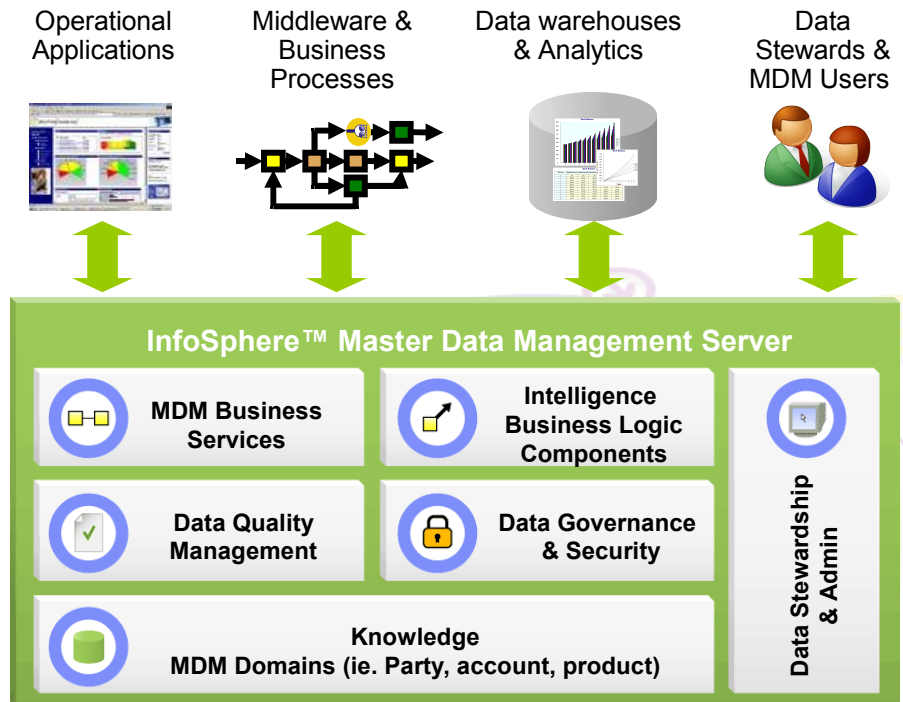

InfoSphere Warehouse on System z

Adds core data warehouse and analytics capability to DB2 for z/OS

- Advanced physical database modeling and design
- In-database data movement and manipulation capabilities of SQL Warehouse Tool (SQW)
- Optimize multidimensional reporting and analysis of data with Cubing Services

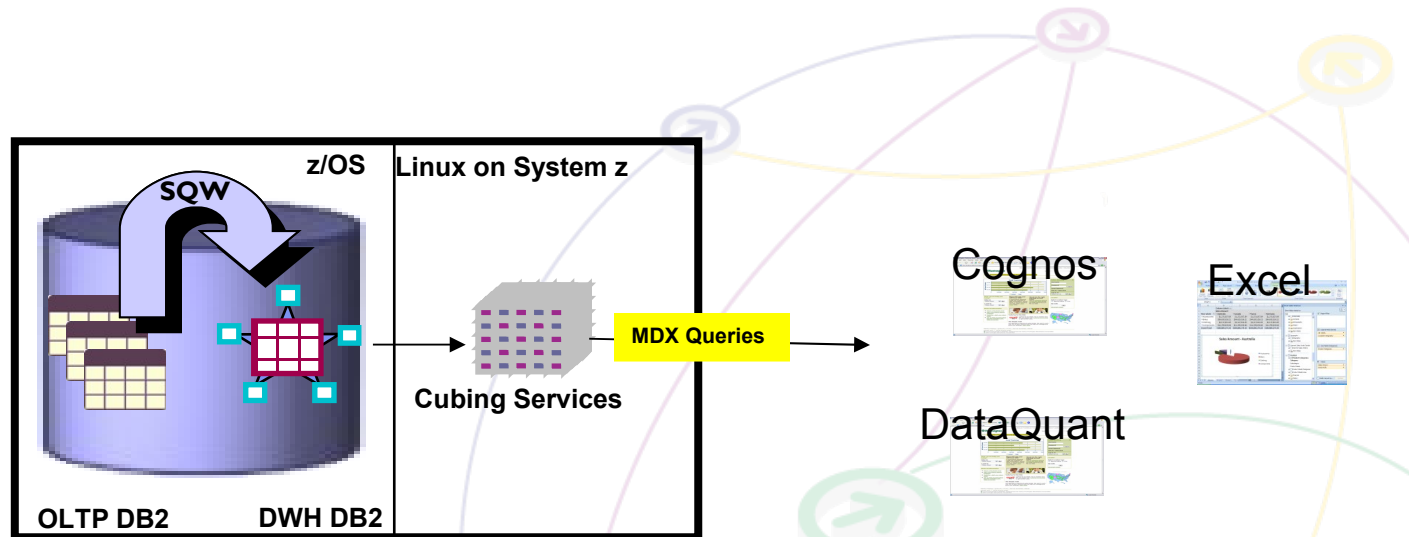

[System z Environment Enhanced with InfoSphere Warehouse](#)



Cognos 8 Bi for Linux on System z

The window to the Information



Built on an SOA to deploy successfully within changing environments

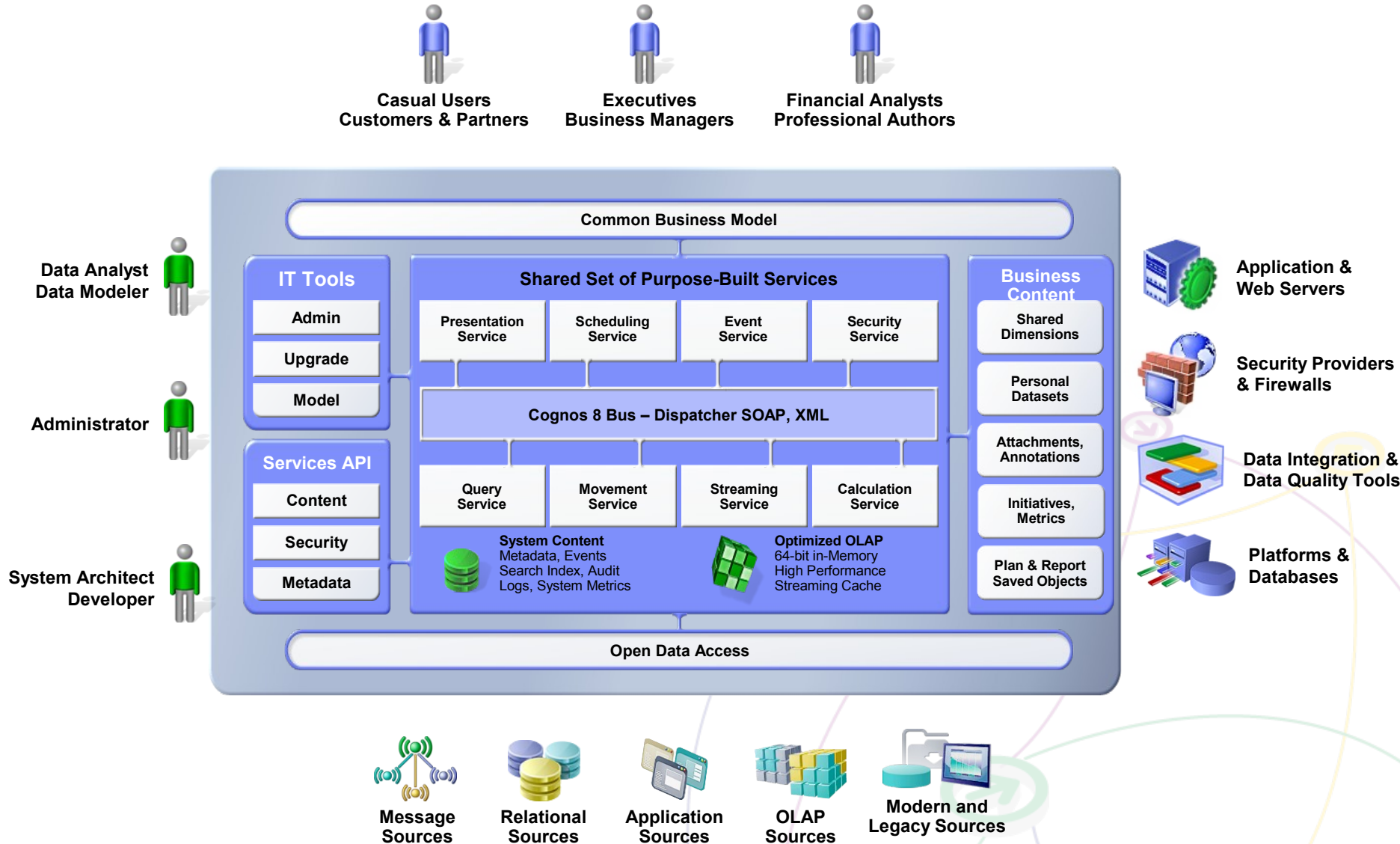

The IBM Cognos 8 platform

PRESENTATION TIER

Broad Range of Capabilities

APPLICATION TIER

Common Set of Services

Common Metadata layer

DATA TIER

Open Data Access

(Transactional, Warehouses or Modern data sources)

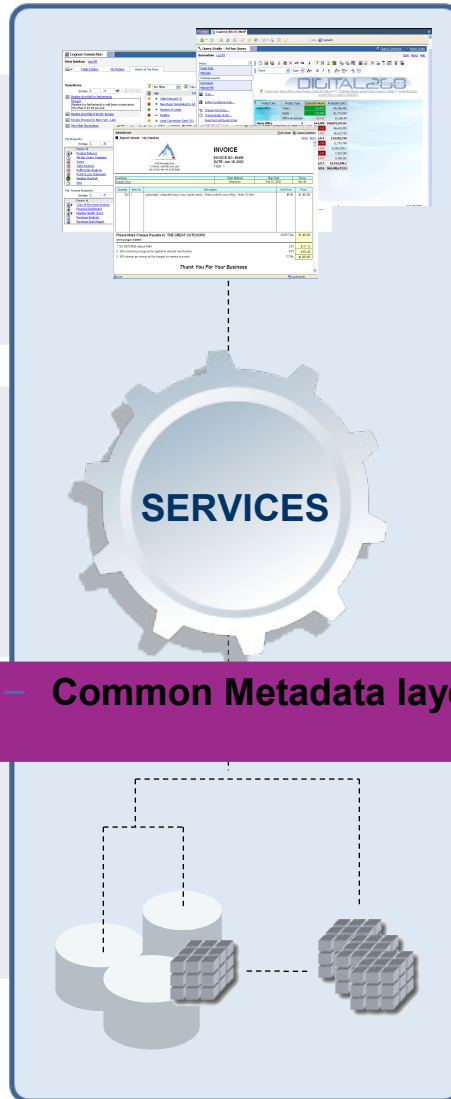



Why Cognos 8 BI for Linux on System z?

- **New workload is moving to System z**
 - Leveraging the platform strengths to improve performance, scalability, reliability, availability, bullet-proof security and energy-saving capabilities of the mainframe
- **Customers are requesting the complete IM portfolio on System z**
 - They want their middleware software running as close to their transactional data as possible
 - To take advantage of a single point of control
 - For close access to data hosted and accessed on System z
- **Benefits of running IBM Cognos 8 BI for Linux on System z**
 - With a BI solution on the same platform as the operational data, customers can reduce the time to access critical operational data which is the foundation of their businesses.
 - IBM Cognos 8 BI for Linux on System z is built on the open Cognos 8 platform so customers can now combine the enterprise-class Cognos 8 platform with the z platform

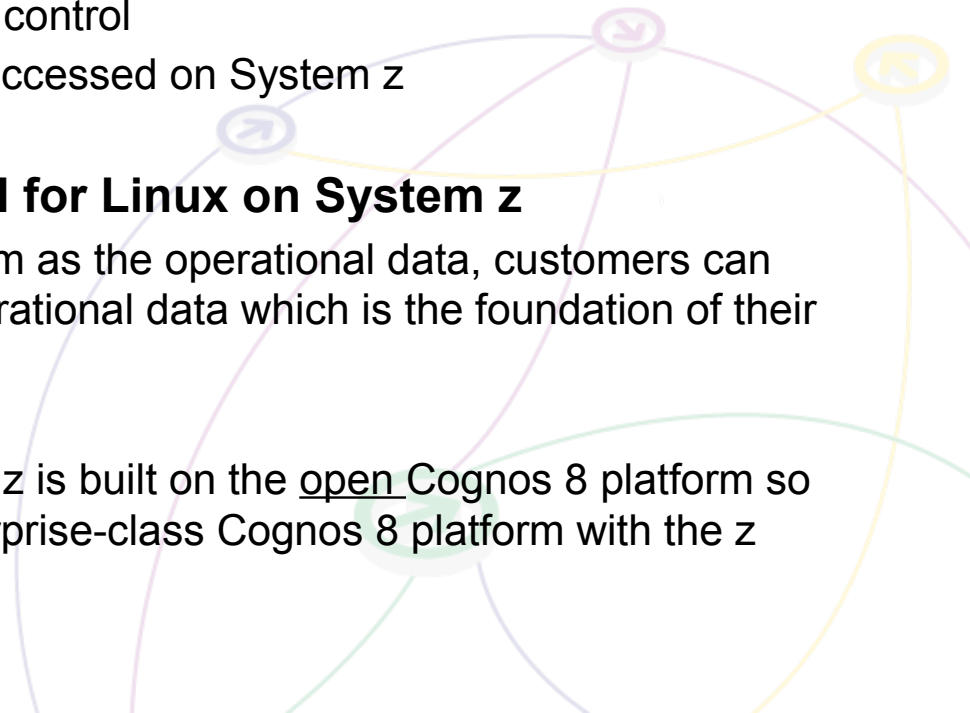



IBM System z

Proven that Cognos 8 BI for Linux for System z can: Scale Across the Enterprise

Testing demonstrated IBM Cognos 8 BI for Linux on System z **scales linearly** to large user groups.

Linear Scalability
IBM Cognos 8 BI for Linux on System z

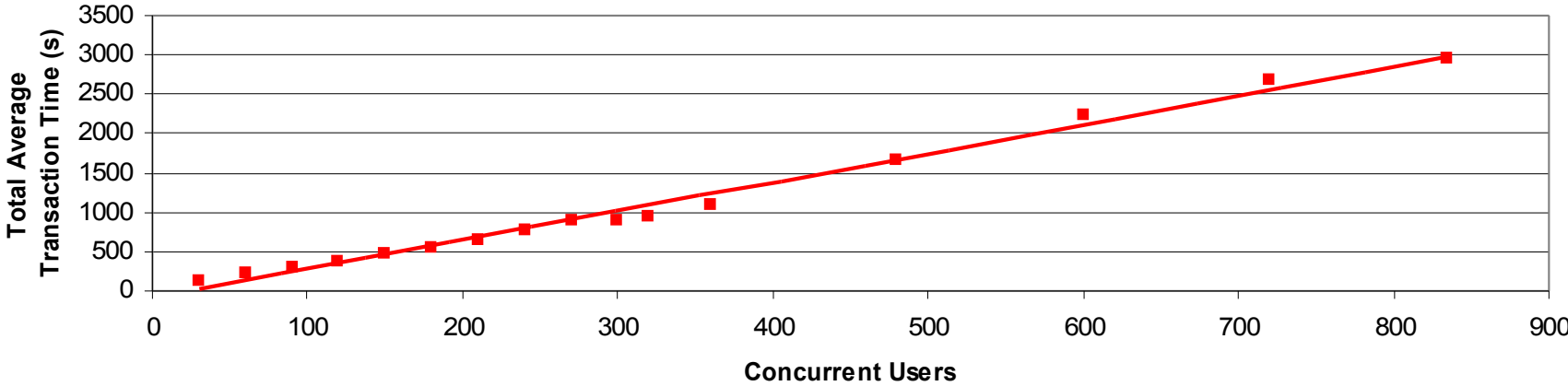

“Cognos, ...makes it easy for companies to deploy BI and PM to a broader user population, while minimizing the resulting workload for IT departments.”
- Nucleus Research, Cognos Takes on the Rest of the Enterprise, November, 2007

■ Testing was conducted on up to **90,000 named users**



Numius Case Study

→ Numius tested an existing customer's distributed Cognos environment on System z

- The application was successfully and without loss of functionality ported to the System z platform. This required no redevelopment.
- The client's application would not require a redesign to accommodate its growth in data volumes or in terms of users.
- Reports that are not practically useable at client's site now become relevant again. Reports that did not run at client's site now are runnable.
- Client would be able to serve many multiples of current number of users with the very simple architecture from this PoC.
- Client could scale out to more complex architecture without increased hardware complexity.
- ***Throughput (not clock speed) 400x that of distributed***

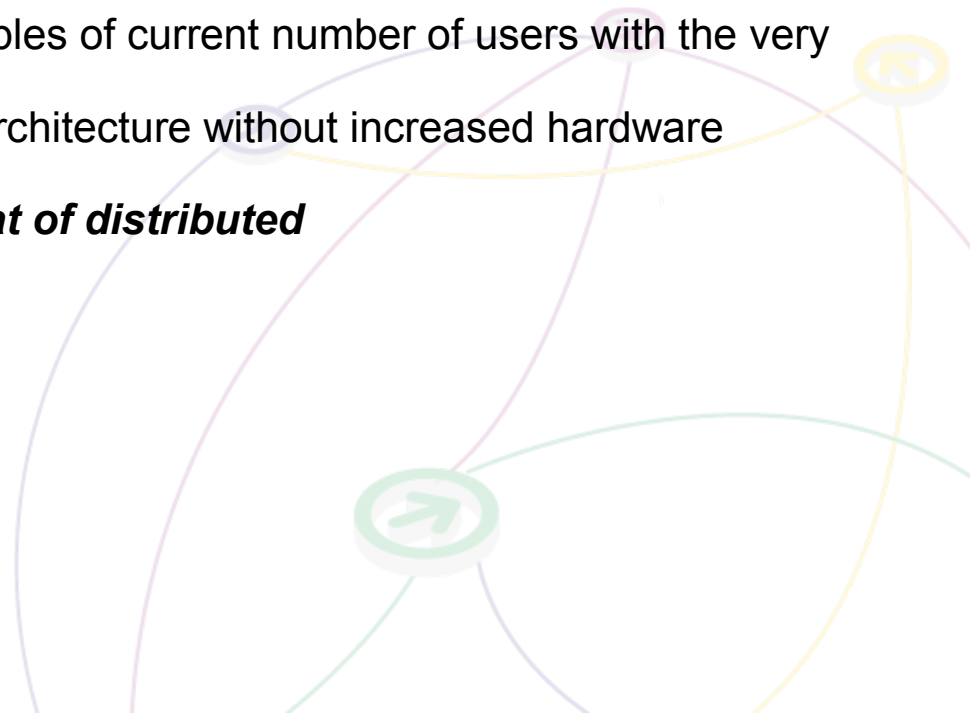



IBM Smart Analytics Optimizer

Technology Preview for System z



Client Need:

Fast and predictable query response time on unpredictable workloads

Lower cost

Better price / performance

The IBM Smart Analytics Optimizer:

Capitalize on data in existing systems by improving performance of typical analytic queries by an order of magnitude

Dramatically reduce administration efforts by reducing the need for database tuning

Significantly improve price/performance with workload optimized software and hardware



IBM Smart Analytics Optimizer

Technology Preview for System z

What is it?

- ✓ A high performance extension that easily integrates with IBM data systems, delivering predictable, order-of-magnitude faster, analytic query response times, while lowering operating costs



How is it different

- ✓ **Deep integration with IBM data management systems**
- ✓ **High performance query software, based on advanced data in-memory technologies**
- ✓ **Leveraging existing data system investment and values without any changes to applications**
- ✓ **For System z, extends gold-standard manageability, security, and availability to high-performance analytic applications**



The Data Warehouse and BI Solution on System z

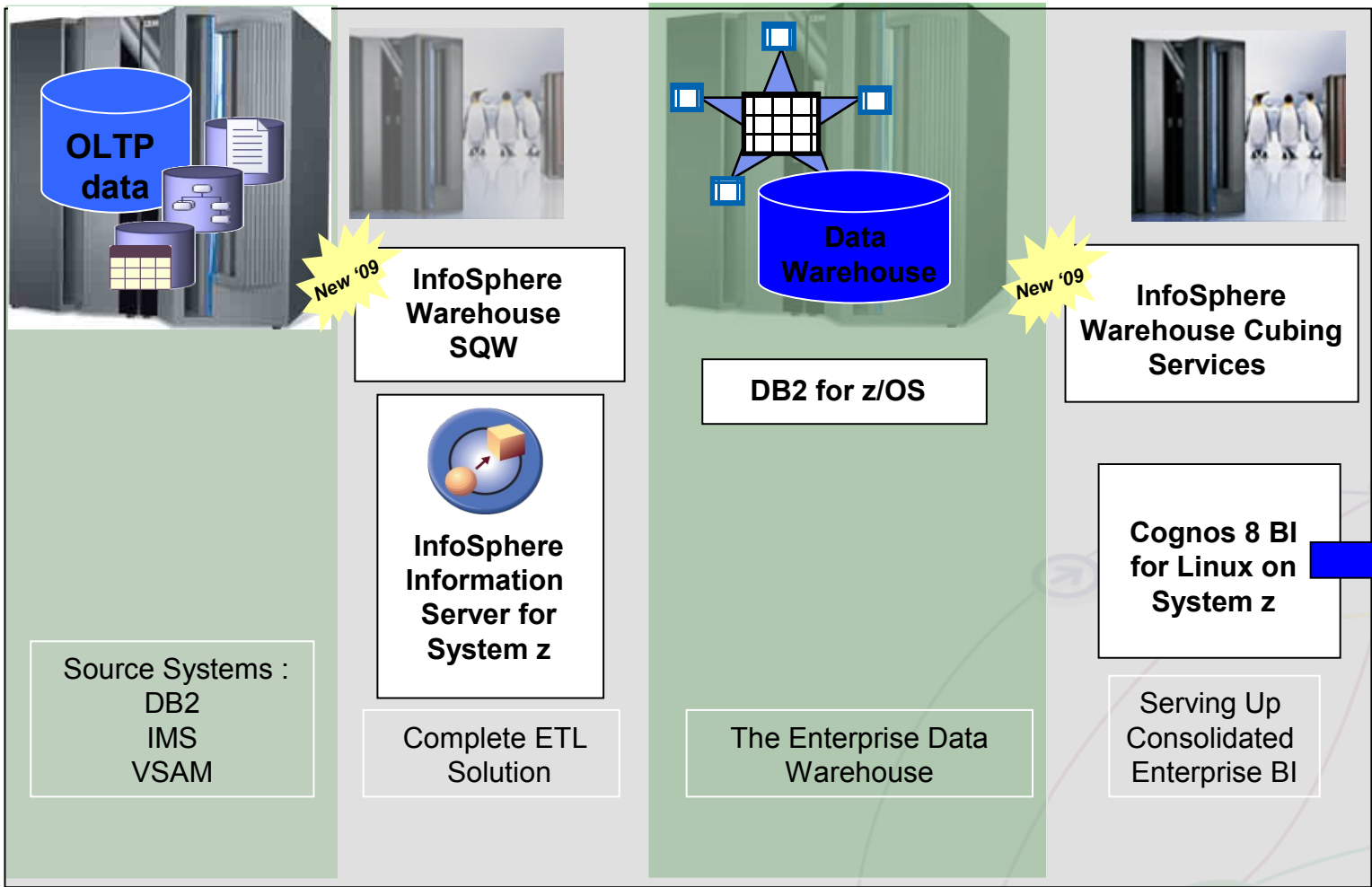

Combining the Reliability and Availability of DB2 for z/OS with Cost Effective Applications running on Linux for System z



Announcing the new System z Solution Editions:

Legendary Mainframe quality, price-competitive with distributed systems which may not be as highly available, reliable, scalable and secure as an IBM System z:

- *Affordable complete stack solutions*
- *Includes IBM System z hardware and Maintenance, IBM Middleware and IBM Services programs for new business functions*
- *Modeled on the successful “SAP Solution Edition” for which IBM has experienced significant growth*
- *Rapid, optimal and cost effective development*
- *Help make mainframe deployment of new workloads affordable, simple, and accessible*

Solution Editions include:

- *Data Warehousing*
- *Security Hub*
- *WebSphere SOA Hub*
- *Application Development*
- *SAP server*
- *ACI Payments Solutions*
- *GDPS DR & HA*
- *Cloud Services Solution*

What: Smart Analytics Cloud

A private cloud optimized for analytic services in large enterprises

Defined as ...

To create...

That delivers ...

Smart Analytics Cloud

IBM Smart Business - services with industry leading hardware & software

A private cloud computing solution for business intelligence (BI) & analytics

A services solution for delivering business intelligence to the entire organization

IBM software

Cognos 8 BI

A broad range of BI capabilities

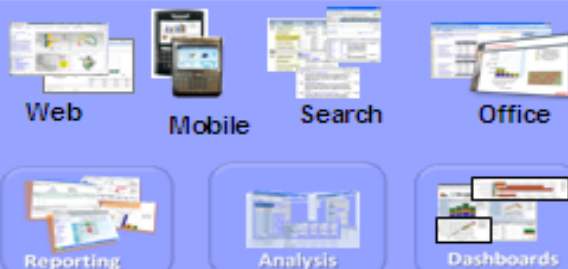

Open, enterprise-class BI platform

IBM hardware

IBM System z

Centralize, Virtualize & Simplify the BI infrastructure



IBM Services

- Create awareness of BI and understand the needs for a BI strategy across the organization
- Complete a readiness assessment to define the scope and priorities for the solution
- Deploy Cognos 8 BI for Linux on System z as a private cloud
- Provide the skills for the on going management & expansion of their BI private cloud deployment



What about the applications?



What happens when logic and data are separated?

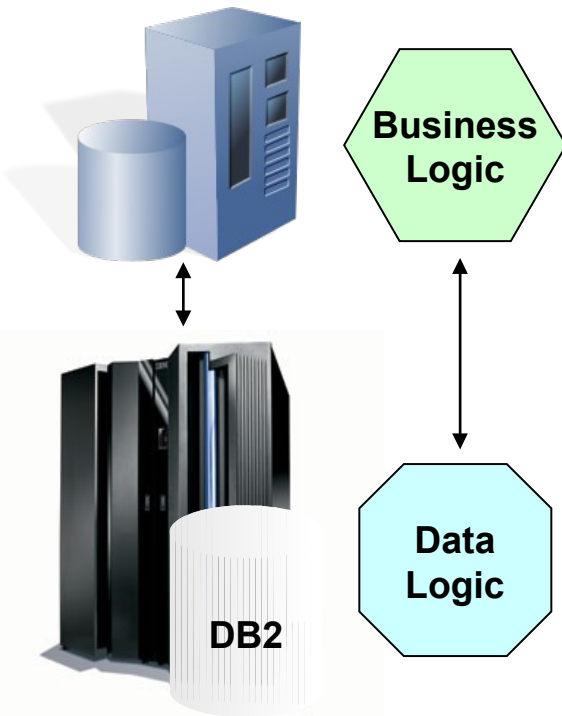

- Objects are converted into byte array at the requester (CPU, time)
- **Network latency is incurred (time)**
- More latency is incurred as service is dispatched (CPU, time)
- Objects are reconstructed at the server (CPU, time)
- Requested data is retrieved
- Objects are converted into byte array at the server (CPU, time)
- **Network latency is incurred (time)**
- Objects are reconstructed at the requester (CPU, time)

Some other considerations:

- Number of interactions between the tiers, volume of data passed
- No local optimizations of the access protocol
- Effect on server memory requirements due to locking

The value of proximity: transportation industry POC

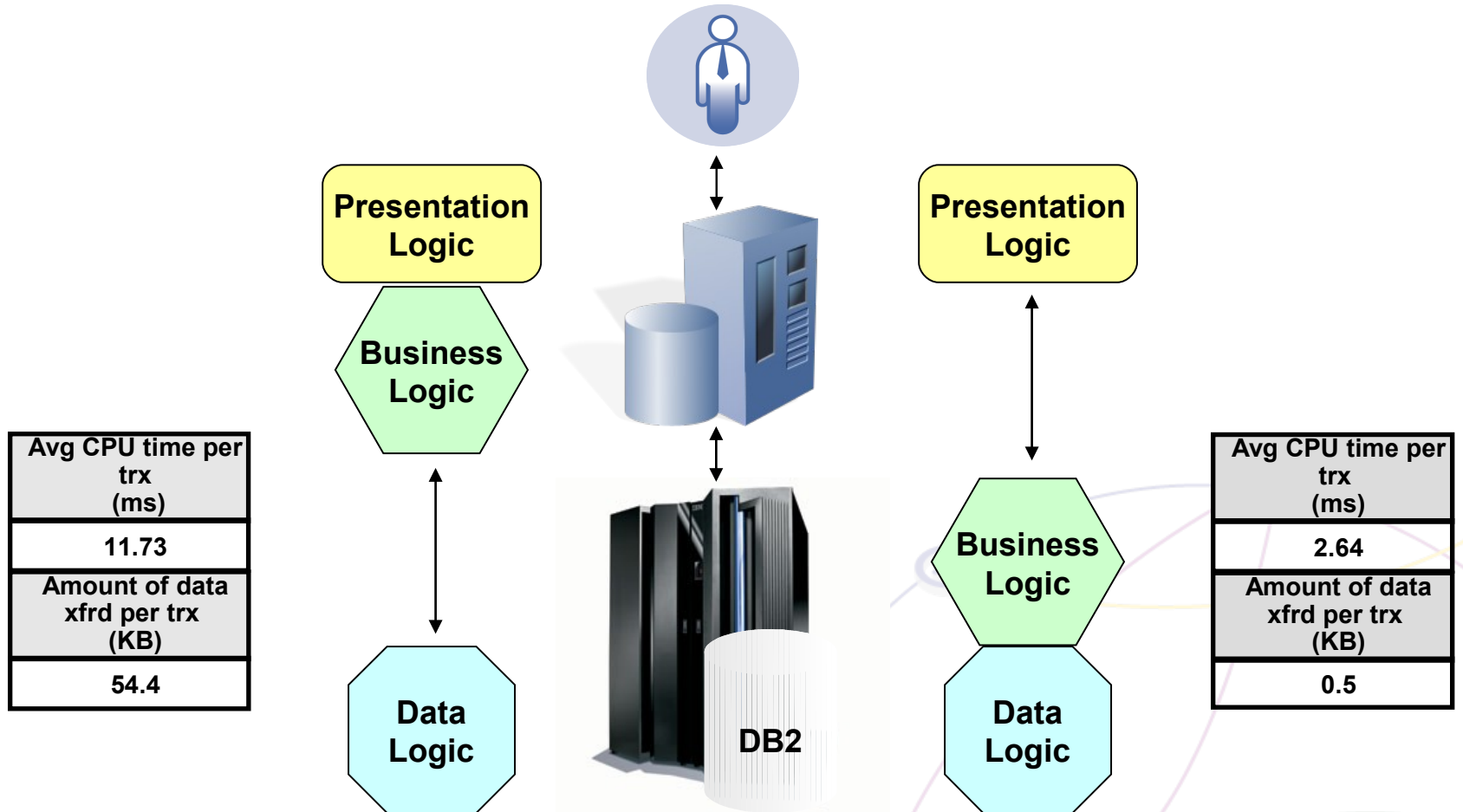

- **Effect of refactoring business logic to be co-resident with z/OS data:**
 - Average CPU time per EJB transaction was reduced by over 77%
 - Number of bytes of data transferred per EJB transaction was reduced by 99%

<http://www.ibm.com/support/techdocs>, Optimizing WebSphere Performance on DB2, WP100558

Enterprise data access with multiple physical tiers versus a single physical tier

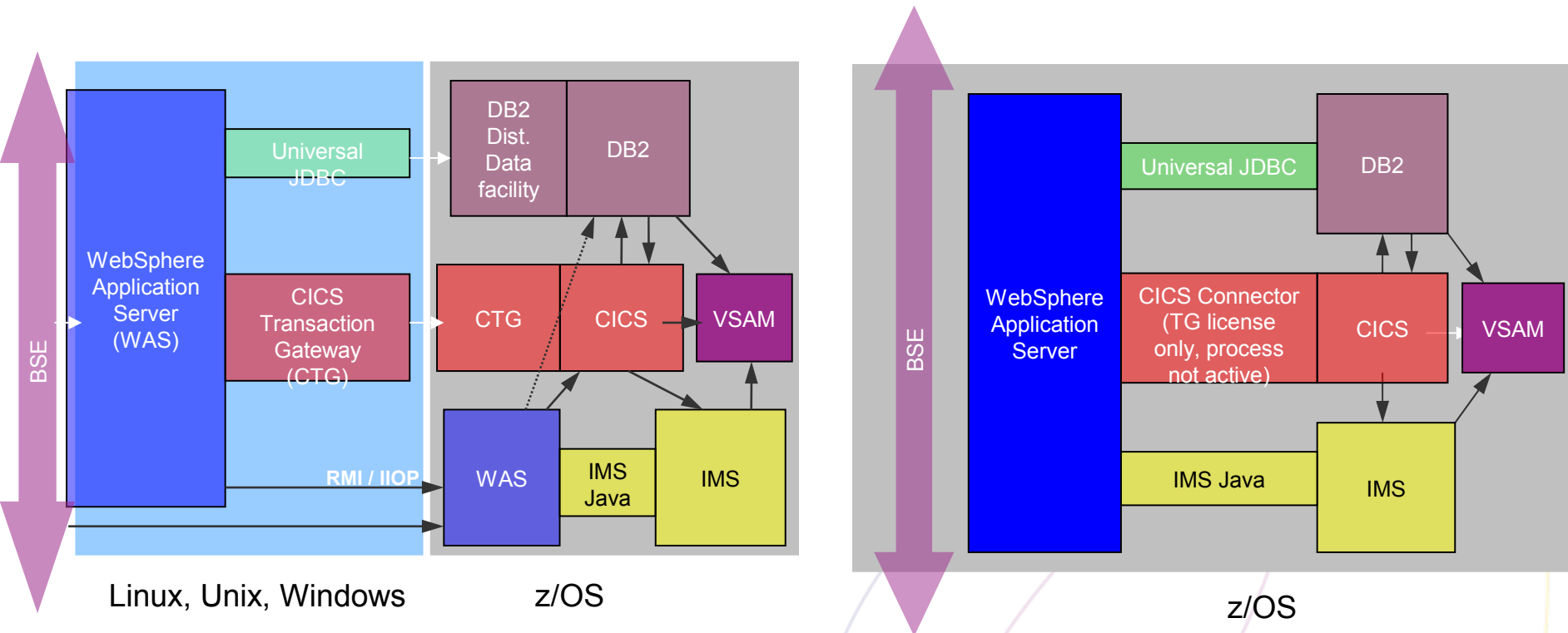

Moving from multiple physical tiers to a single tier provides many benefits, including tighter security, enhanced management, reduced costs, and performance gains.



Function

Deciding where to deploy applications



Windows

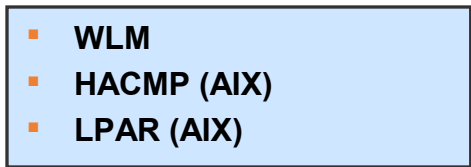

AIX/UNIX/Linux

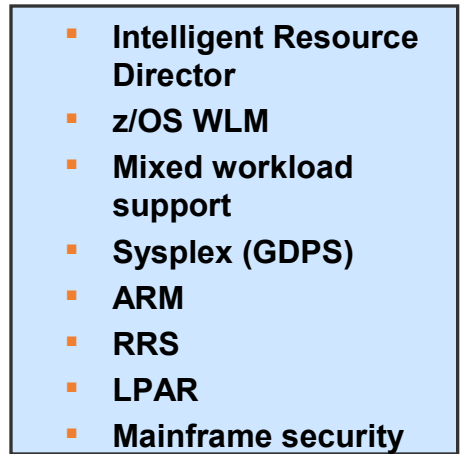

z/OS

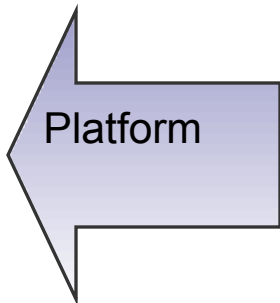

The first step in deciding where to run your applications is evaluating your platform options based on the needs of your application

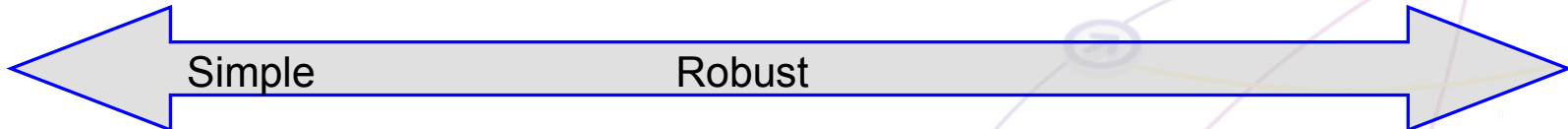

✓ Little OS function

✓ Simple Workload management

✓ Resource provisioning on demand

✓ Zero downtime

✓ Availability

✓ Prioritization of diverse workloads

✓ Some virtualization of resources

✓ Support for complex transactions

✓ Stalwart security model

Watch terminology - **Not** equivalent across platforms



Deciding where to deploy applications

Factoring in the value of the application server

Function

The second step in deciding where to run your applications is evaluating your application server options

Windows

- WAS delivers:**
- High availability
 - Clustering
 - J2EE 1.4
 - Web Services
 - Security
 - Messaging

AIX/UNIX/Linux

- WAS delivers:**
- High availability
 - Clustering
 - J2EE 1.4
 - Web Services
 - Security
 - Messaging

z/OS

- WAS delivers:**
- High availability
 - Clustering
 - J2EE 1.4
 - Web Services
 - Security
 - Messaging
 - Platform optimization
 - ✓ Mainframe security
 - ✓ Sysplex support
 - ✓ z/OS WLM architected inside
 - ✓ Tight integration with DB2, CICS
 - ✓ Complex transaction support

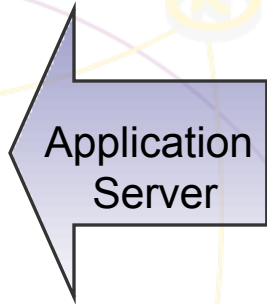

WebSphere Application Server offers common schedules and a programming model across the releases

Summary





A Multitude of Information Projects

Each successful in its own right; but limited speed and flexibility...

Large Global Bank

- 5 data warehouse projects in 5 years
- Large customer call center deployment
- Reengineered CIF System
- Millions invested



*“I still can’t sleep at night;
I don’t have a real time and accurate view into my risk posture” - Chief Risk Officer*

“I still can’t tell you who our most profitable customers are, let alone serve them well across my channels” - Chief Information Officer

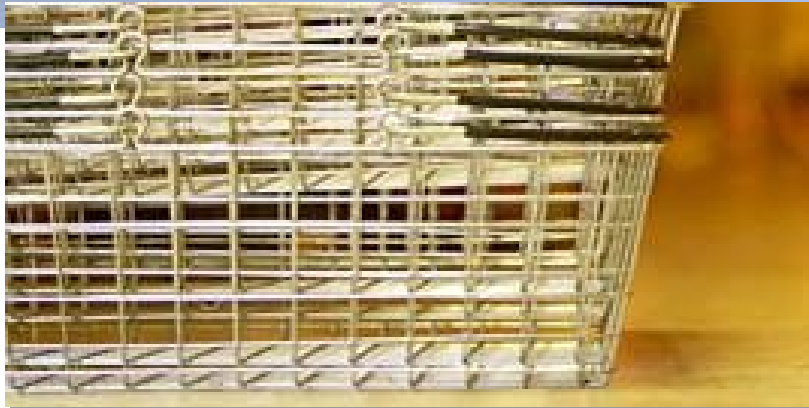

Multi-channel Apparel Retailer

- 3 brick & mortar and 1 web channel
- Multiple customer loyalty systems
- Multiple call centers
- 1 credit card



Becoming an Information Based Enterprise...

Information Agenda: The 5th entry point of Information On Demand

Creating an information agenda helps transform information into a trusted strategic asset that can be rapidly leveraged across applications, processes and decisions for sustained competitive advantage.

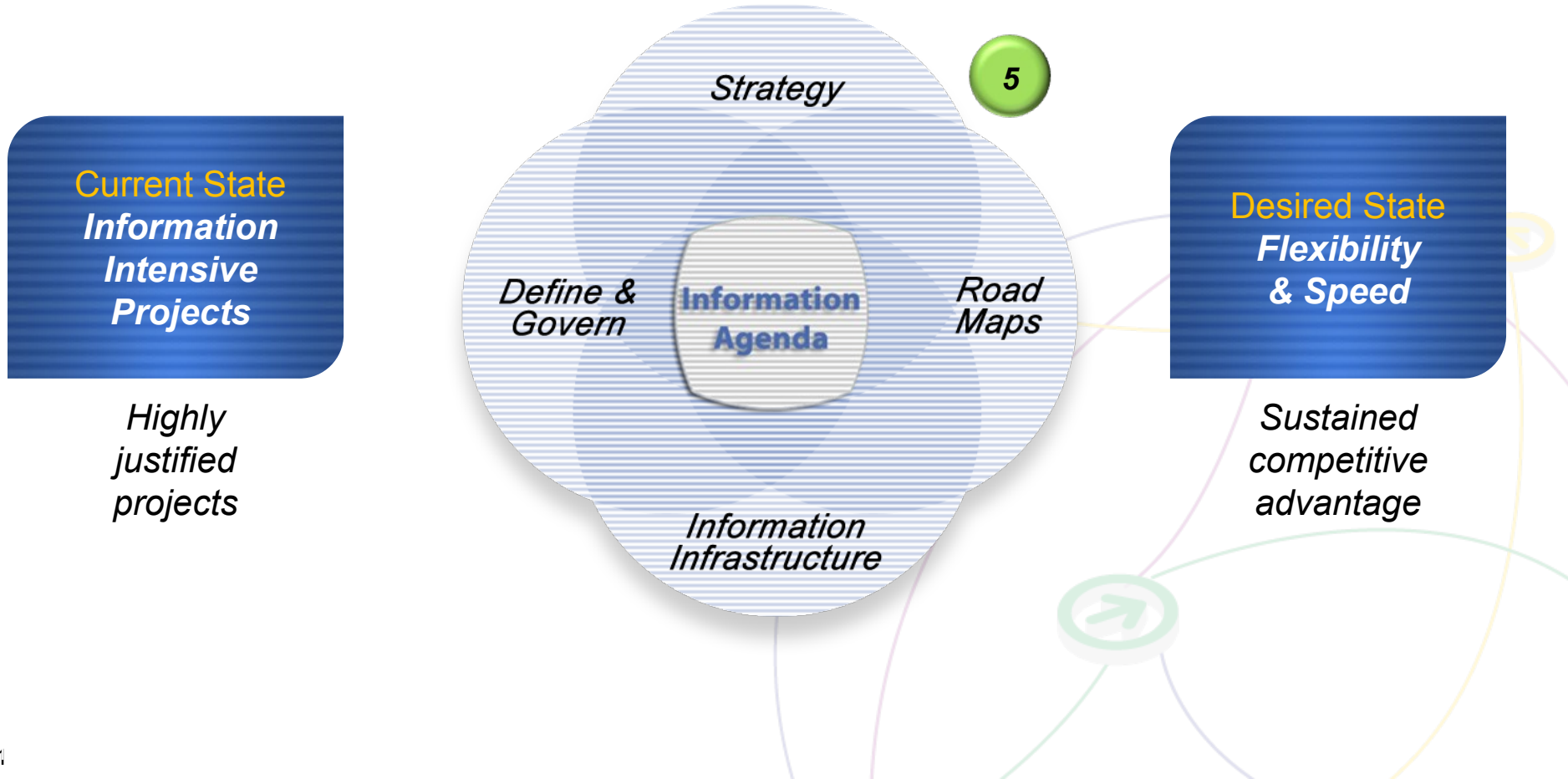



Typical Utilization for Servers

Windows: 5-10% Unix: 10-20% **System z: 85-100%**

System z can help **reduce** your floor space up to **75%-85%** in the data center



Thank You



System z can lower your total cost of ownership, requiring **as little as 30%** of the power of a distributed server farm running equivalent workloads

The cost of storage is typically **three times more** in distributed environments





Backup





InfoSphere Foundation Tools

Software to help convert your information into a trusted strategic asset

Open tools that provide value to any data integration, business intelligence, or data warehouse projects...

Only IBM has invested to provide the breadth of capabilities to define and govern your information...

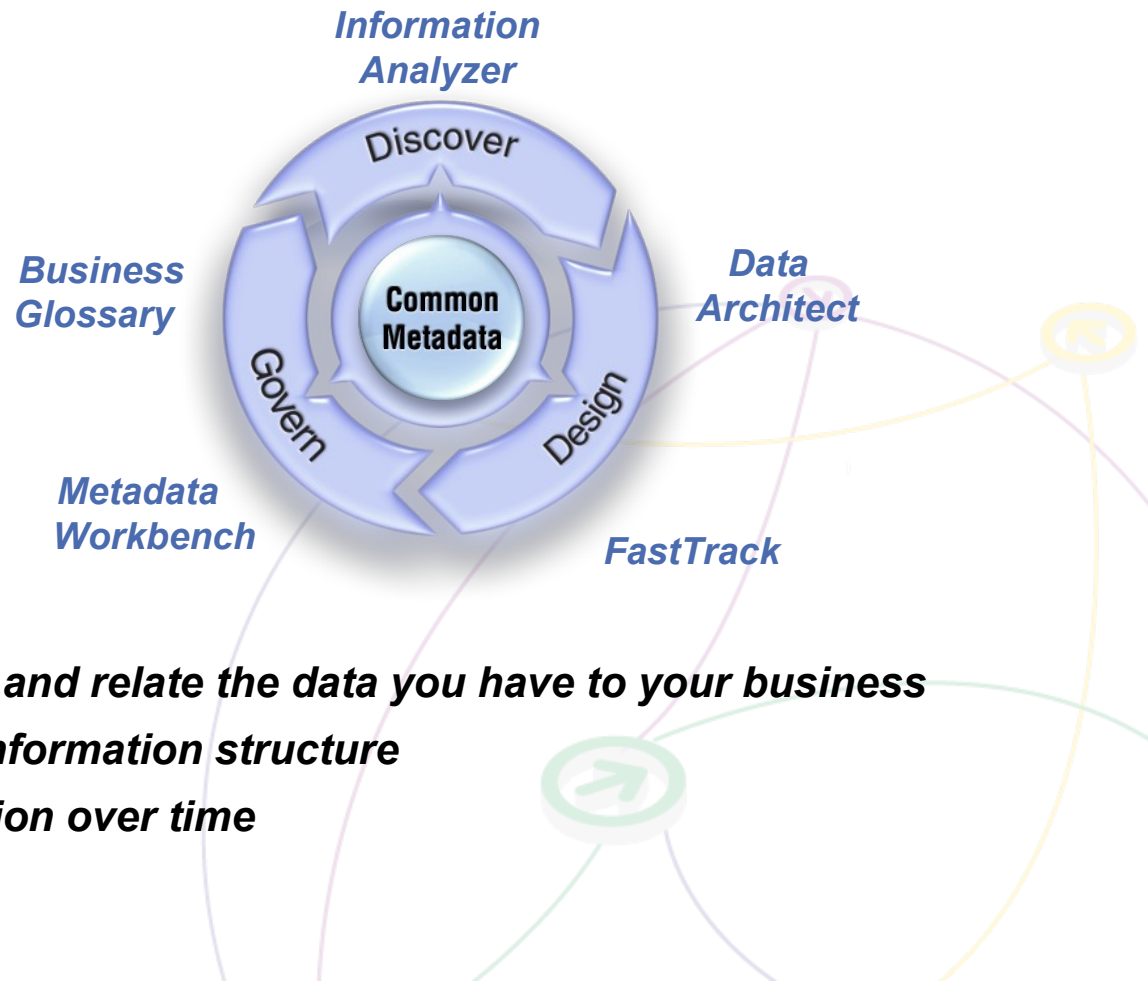

- ***Discover, understand and relate the data you have to your business***
- ***Design your trusted information structure***
- ***Govern your information over time***

Platform Matters

WebSphere Deployment options

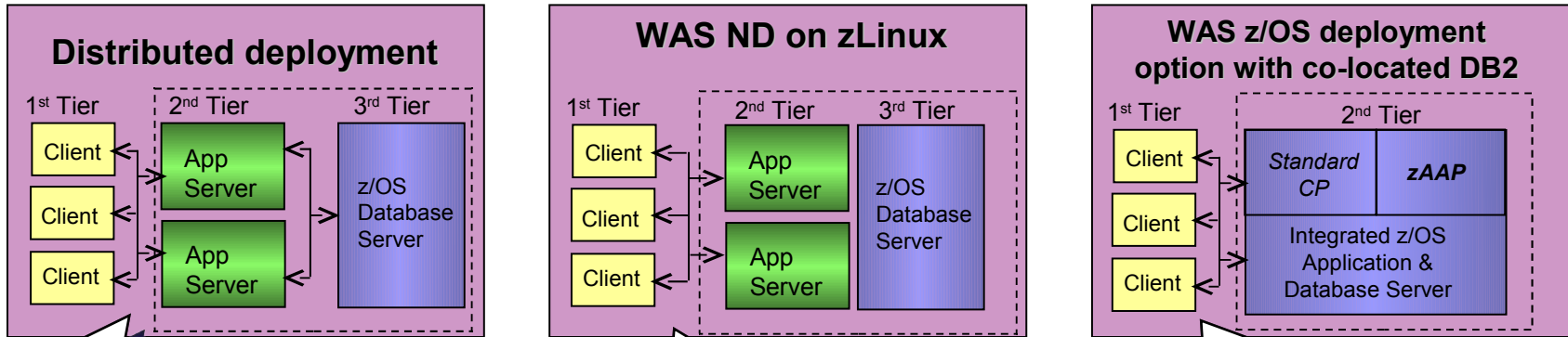

Typical distributed deployment with:

- Network layer between each tier
- Normal access to z/OS DB limited by the network overhead and processor speed

Typical distributed deployment on the mainframe with:

- Ability to use hipersockets for faster DB transactions
- Normal DB access

Unique configuration only for WAS z/OS with:

- Memory to memory transfer rates with DB (Type 2 connections) for high volume transfer rates
- Remove network layer and overhead



DB2 X for z/OS At a Glance

Application Enablement

- Versioned data biTemporal
- pureXML enhancements
- Last Committed reads
- SQL improvements that simplify porting

RAS, Performance, Scalability, Security

- Wide range of performance improvements
- Hash access to data
- More online schema changes
- Catalog restructure for improved concurrency
- Row and column access control
- Administrator privileges with finer granularity

Simplification, Reduced TCO

- 5 – 10 times more threads per DB2 image
- Auto statistics
- Data compression on the fly
- Query stability enhancements
- Reduced need for REORG
- Utilities enhancements

Dynamic Warehousing

- Moving sum, moving average
- Many query optimization improvements
- Query parallelism improvements
- Advanced query acceleration

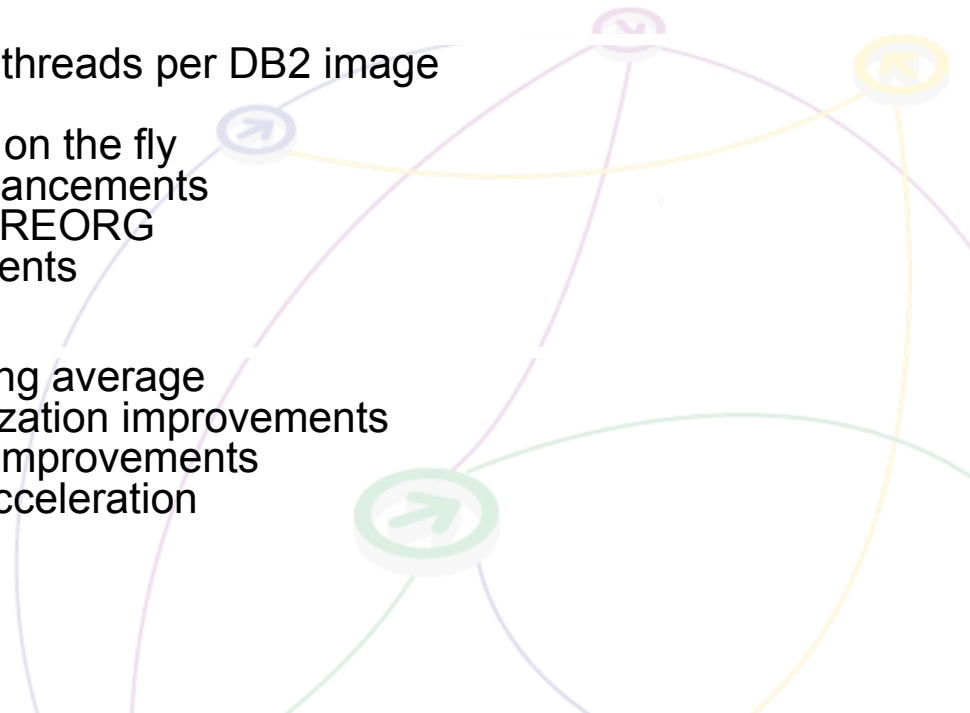



System z: The platform for the future

"you cannot think seriously about your longer-term IT architecture without thinking equally seriously about what today's mainframe environment has to offer"



CIO Magazine: Mainframe computing is set for a rebirth – September 29, 2009

IBM Information Agenda

The New Intelligence for a Smarter Planet

Mike Biere
WW Sr. Technical Marketing Manager
IBM Silicon Valley Lab, San Jose, California





The Information Challenge...

52% of users
don't have confidence
in their information



42% of managers
use wrong information
at least once a week

**Leveraging Information
for Smarter Business Outcomes**

**Core & Other
Operational Systems**

Organizations are Increasingly Focused on Leveraging Information for Smarter Business Outcomes

2X

Client Investment in Business Optimization Projects is Growing over Twice as Fast as Business Automation

Business Automation
\$566B
3% CGR

Business Optimization and Analytics
\$105B
8% CGR

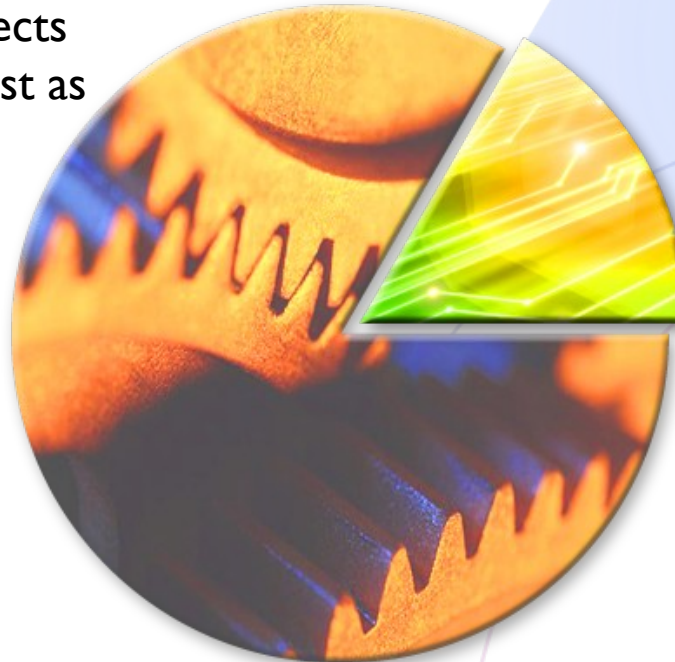

IT Spending Estimates, 2009*

* Includes Hardware, Software and Services. Does not include Networking, Printer, or Standalone Printer or PC Markets. CGRs 2009–2012. Opportunity estimates based on analysis done by the IBM Market Intelligence Department. IBM Market Intelligence data is provided for illustrative purposes and is not intended to be a guarantee of market opportunity.

Information Must Be Trusted, Pervasive and Increasingly Predictive & Immediate to Lead Business Transformation



Retail

“... Are our price points below or above those of key competitors, and by how much?”

“...If below, is this sustainable given our cost profile, or is costly a future threat?”

“...What premium will customers pay for value-added propositions?”

“...what offer can I make to this customer right now to best increase profitability?”



Banking

“...What is my risk this morning and how have the credit limit changes been impacted my closing rates?”

“...Do we suspect any SEC violations?”

“...can I safely approve this transaction right now with low risk?”



Government

“...Which programs should continue to get our stimulus funding, what is their status and how effective the funds being used?”

“...Which funds are being used outside the bounds of the original proposal?”



Healthcare

“...What emerging treatment may relate to this patient?”

“...Which treatments are ineffective and should be eliminated to help lower costs?”

“...Do any of my patients need attention right now to avoid a potential problem?”



Industrial

“...What can we do to minimize warranty claims?”

“...Do we have there fraudulent claims coming in from our northeast service centers?”

“...Do we have any regulatory exposures and what safety risks might be related?”



Communications

“...How and when should I adjust my global offering prices to reduce churn in my existing market and expand share in an emerging market?”

“Is my network at risk of failure that can be avoided if I take protective action right now?”





Getting started with an information-led transformation

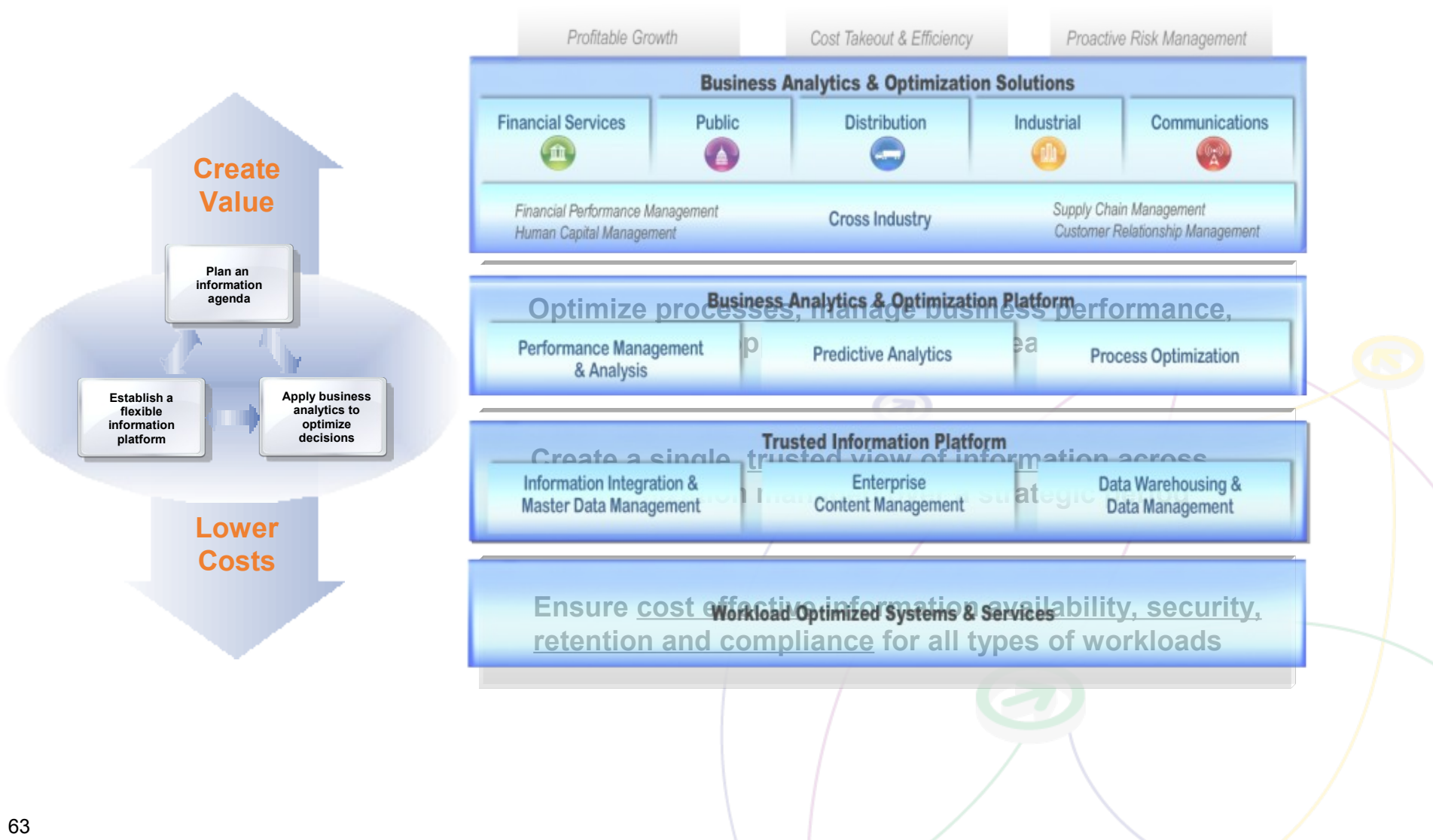



Leveraging System z for Information On Demand

More new capabilities delivered in the past 3 years than at any point in the mainframe's history

SPSS and much more coming .

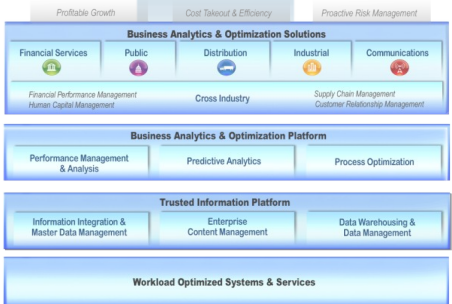

InfoSphere Warehouse for System z

InfoSphere Global Name Recognition for System z

FileNet Content Manager for System z

Cognos 8 BI for System z

Data Studio pureQuery for System z

InfoSphere MDM Server for System z

Optim Data Governance for System z

Information Server for System z

Content Manager 8.4

DB2 9 IMS 10

for z/OS

2007

ETL & Data Quality

SOA

Data Warehousing

Data Archiving
Test Data Mgmt

App Dev Tools

Info Agenda
Launch

Business
Intelligence

DW Tools

Open
Access

2009

IMS 11

IOD
Launch
2006

pureXML

DB2.
software

InfoSphere™
software

Cognos.
software

FileNet.
software



Managing the data



IMS

→ IMS 10 encourages business growth while still keeping cost in check.

Many companies are searching for ways to increase the flexibility and reuse of their existing IT assets.

→ IMS 11 is designed to drive efficiency and lower costs while simplifying administration and enabling greater business flexibility

- IMS Open Database support allows any application on any platform to access IMS data directly and transparently
- Enhanced application development tooling allows easier application development and modernization
- Autonomic computing capabilities relieve skill constraints
- Raising the performance bar again - extreme performance with greater than 22,000 transactions/second

Analysts Agree!



“As IMS continues to evolve, it should be able to maintain a strong claim on the highly complex data management and high throughput workloads that it has historically served so well.” *Carl Olofson, IDC*



Interesting Facts about DB2 for z/OS



→ **Used by...**

- The top 59 banks in the world
- 23 of the top 25 US retailers
- 9 of the top 10 global life/health insurance providers

→ **Performance, Performance, Performance**

- Delivered the largest banking benchmark ever at the Bank of China, a record 9,445 transactions per second
- 15,000 Transactions per second, almost 300,000 SQL/sec for large Asian bank benchmark.
- Supports the world's largest known peak database workload - 1.1 Billion SQL statements per hour at UPS
- The world's largest known transaction processing database – 23.1 TB at UK Land Registry

→ **Availability, security, advanced virtualization**

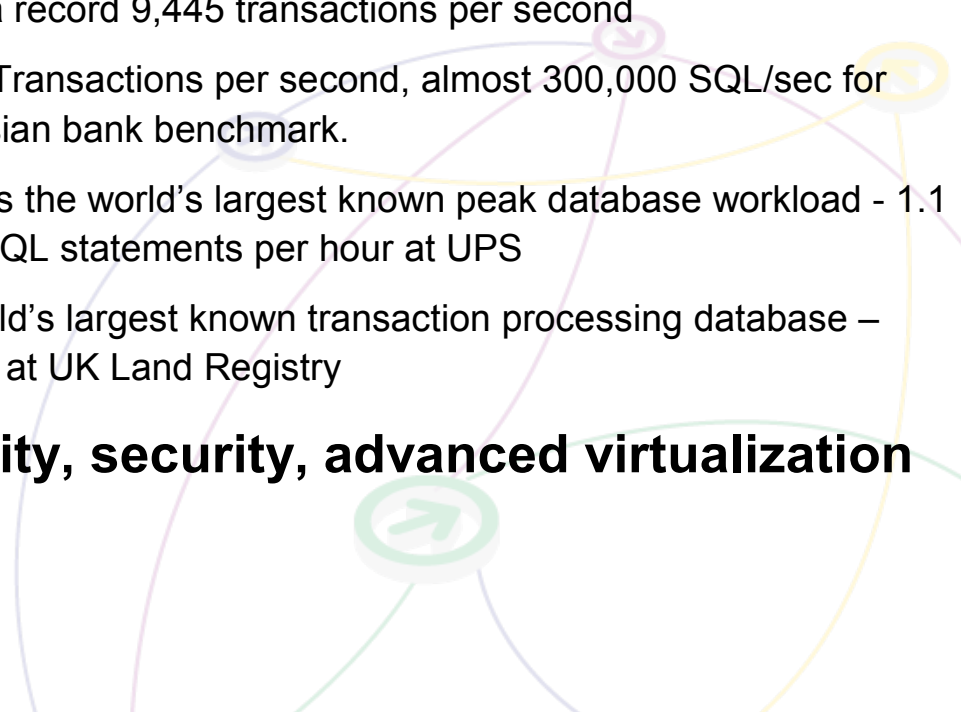



DB2 and IMS Solutions that manage the value of your data throughout its lifetime

InfoSphere Data Architect

Optim Data Growth Solution
DB2 Performance Mgt Solution
IMS Performance Mgt Solution

Optim Development Studio
Optim Test Data Management
Optim Data Privacy Solution

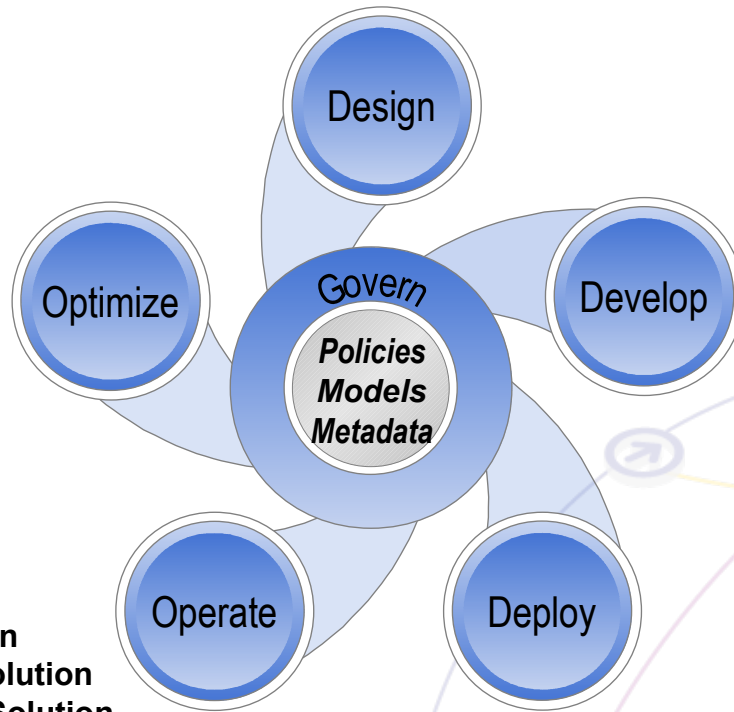

DB2/IMS Administration Solution
DB2/IMS Backup & Recovery Solution
DB2/IMS Utilities Management Solution
IMS Transaction Management Solution

Optim Development Studio
Optim pureQuery Runtime
DB2/IMS Application Mgt Solution

DB2/IMS Data Governance Solution





A Customer Success Story – Migration to IBM DB2 and IMS Tools

Challenges

- ❑ Largest savings bank in Spain.
- ❑ Needed to lower mainframe software costs
- ❑ Operated a complex z/OS environment, managing more than 20TB of IBM DB2 software data and more than 30TB of data hosted on IBM IMS software databases.
- ❑ “No impact in production” policy

la Caixa turned to IBM to provide more cost-effective tools for this system

Solutions

- ❑ IBM DB2 Tools: DB2 Administration Tool, DB2 Automation Tool, DB2 Query Monitor, DB2 SQL Performance Analyzer, DB2 Utilities Suite, DB2 High Performance Unload, DB2 Change Accumulation
- ❑ IBM IMS Tools: IMS HP Fast Path Utilities, IMS HP Change Accumulation, IMS Index Builder, IMS DEDB Fast Recovery, IMS Database Recovery Facility, IMS HP Image Copy

Benefits

- ❑ No disruption to business during and after migration
- ❑ Experienced easier contract agreement
- ❑ Products that keep pace with IMS & DB2 development
- ❑ Can exploit new IMS and DB2 functions in the IBM tools

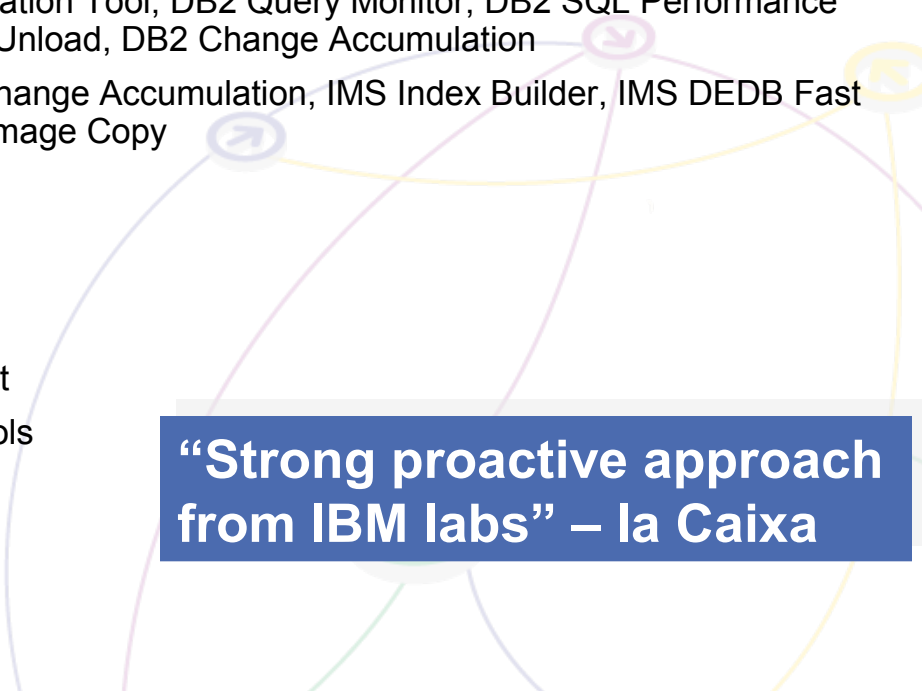

**“Strong proactive approach
from IBM labs” – la Caixa**

Managing Content



ECM Market Drivers/State of the Industry: 2009

2008

1. Cost savings: 44%
2. Compliance: 39%

2009
1. Cost savings: 50%

2. Compliance: 34%



“Cost saving has taken a clear lead over compliance as the main business driver for investments in document and records management.” — AIIM

Other survey results

- 56% of organizations still have little or no confidence that important emails are recorded, complete and recoverable (62% in 2008). 27% consider email attachments “very unmanaged”
- 28% of organizations would take more than a month to produce documents for a legal discovery process
- 34% planned to migrate to a single ECM system

AIIM State of the Industry Survey, March 2009

IBM ECM Product Vision

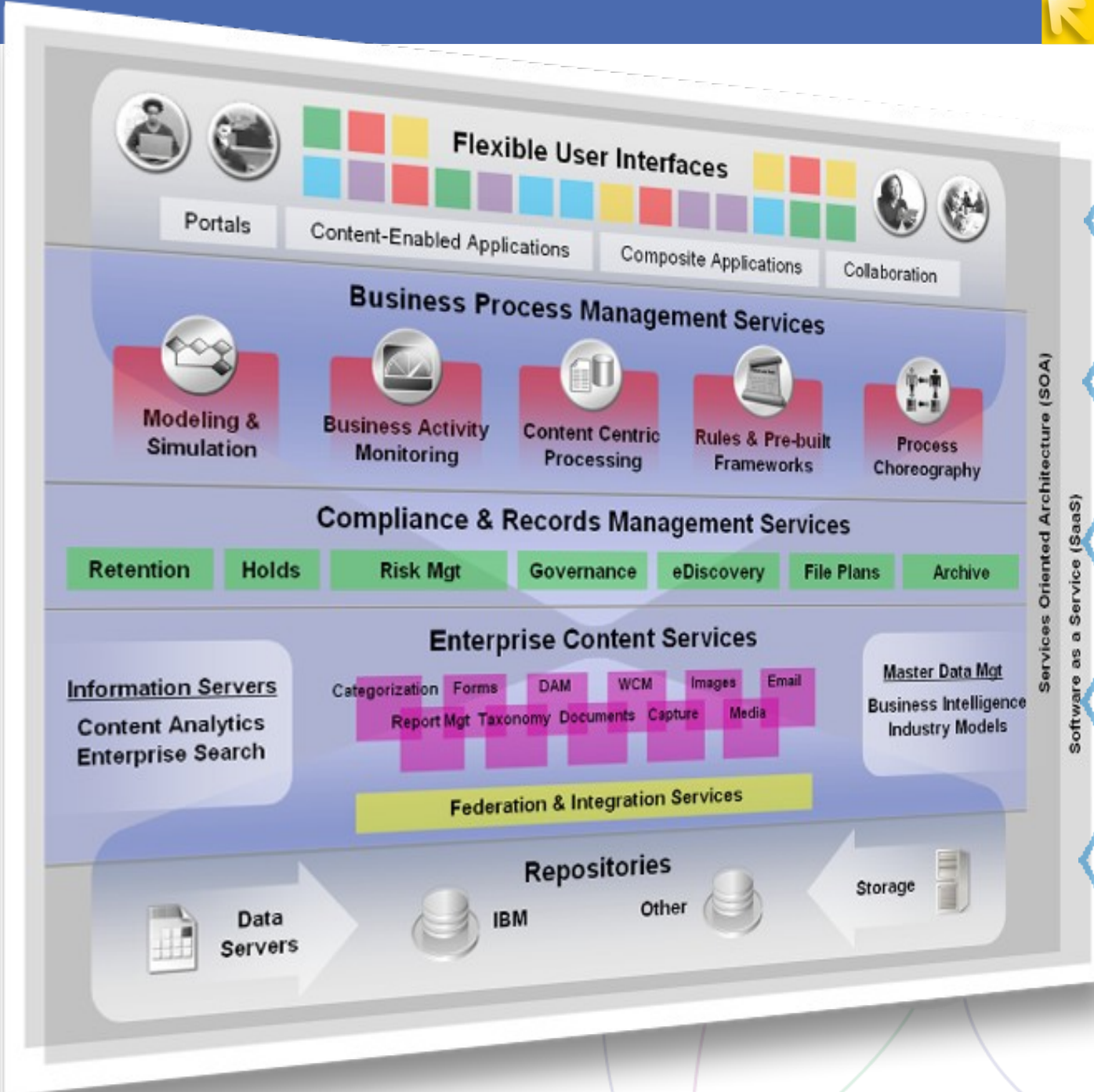

Pervasive
Persuasive

Business
Agility

Enterprise
Compliance

Active
Content

Content
Anywhere



ECM Products on System z

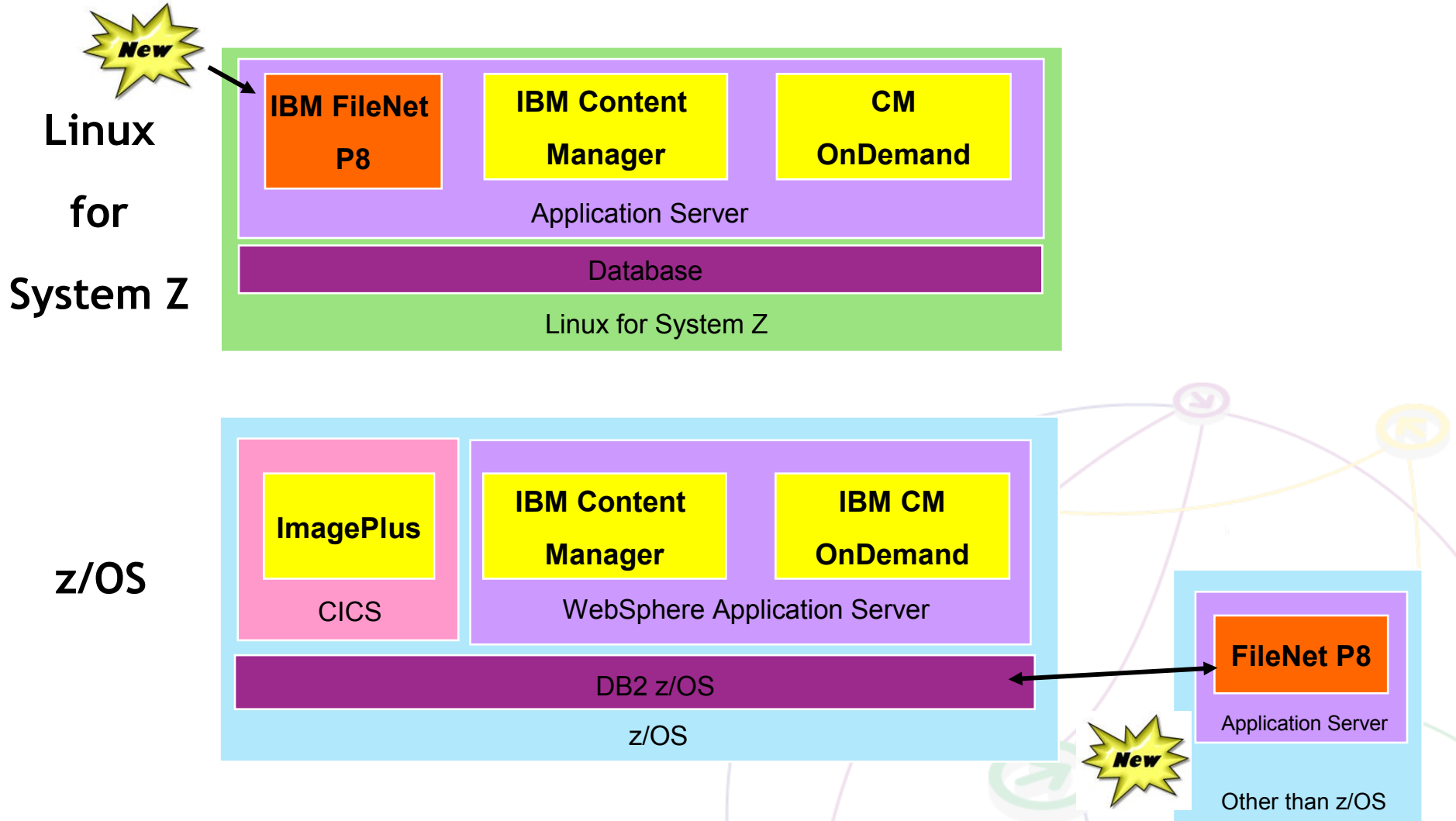



The Value of ECM on System z

- Excels at “mission critical” applications
- Delivers new business capability faster
- Offers higher security and control
- Drives economies of scale and reduces TCO of solution
- Ball State University - deployed on System z to harness the reliability, scalability, versatility, and power of the System z platform while reducing their energy consumption in an overall “greening” effort
- Primerica Financial - deployed on System z because they believe it is the best platform to achieve the availability and scalability they need, that it facilitates disaster/recovery and information security administration, and that it provides the best overall total cost of ownership.
- Health Care Service Corporation – deployed ECM on System z to extend their existing infrastructure, skills and disaster recovery solution to their ECM applications and is deploying next applications on Content Manager (z/OS) using Web services

Control of the Information





Managing your business environment

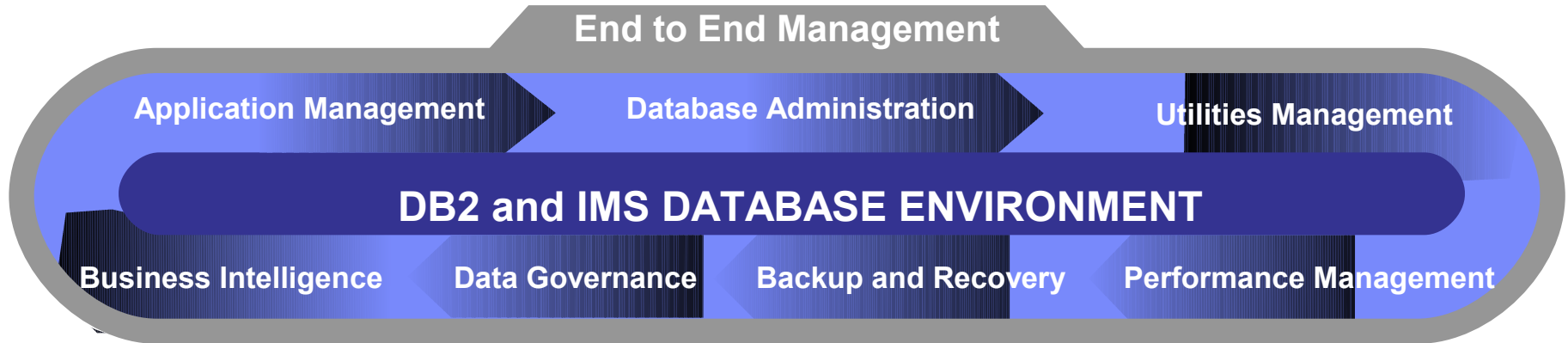

Business Challenges

- Optimizing costs associated with maintaining existing applications
- Quickly responding to new business requirements and opportunities
- Ensuring that business and regulatory needs can be properly met
- Maximizing IT staff productivity to streamline business operations



Enterprise Data Governance

- Data breaches, corporate mistakes, use of bad data continue to make headline news
- Every organization is concerned with regulatory compliance, security, privacy, data quality. Bad data is bad for business.
- IBM created three entry points that enable customers to address their more pressing needs while embracing other aspects of data governance as and when required :
 - *Information Quality – understand, analyze, cleanse, transform, deliver*
 - *Lifecycle Management – collect, store, process, optimize, manage, report, retain*
 - *Information Protection – security, privacy, audit, logging, reporting*

Accenture survey 75 percent of CEOs want to better manage and use their information ,78 percent believe they can achieve better competitive advantage, only 15 percent are comprehensively managing their data.

Data Governance is fundamental to successful BI and DW projects.



Enterprise Data Governance for System z

- Archive inactive data
lower storage cost

Optim Data Growth Solution

- Comply with internal and external auditing requirements

DB2 / IMS Audit Mgt. Expert
Tivoli Compliance Insight Manager

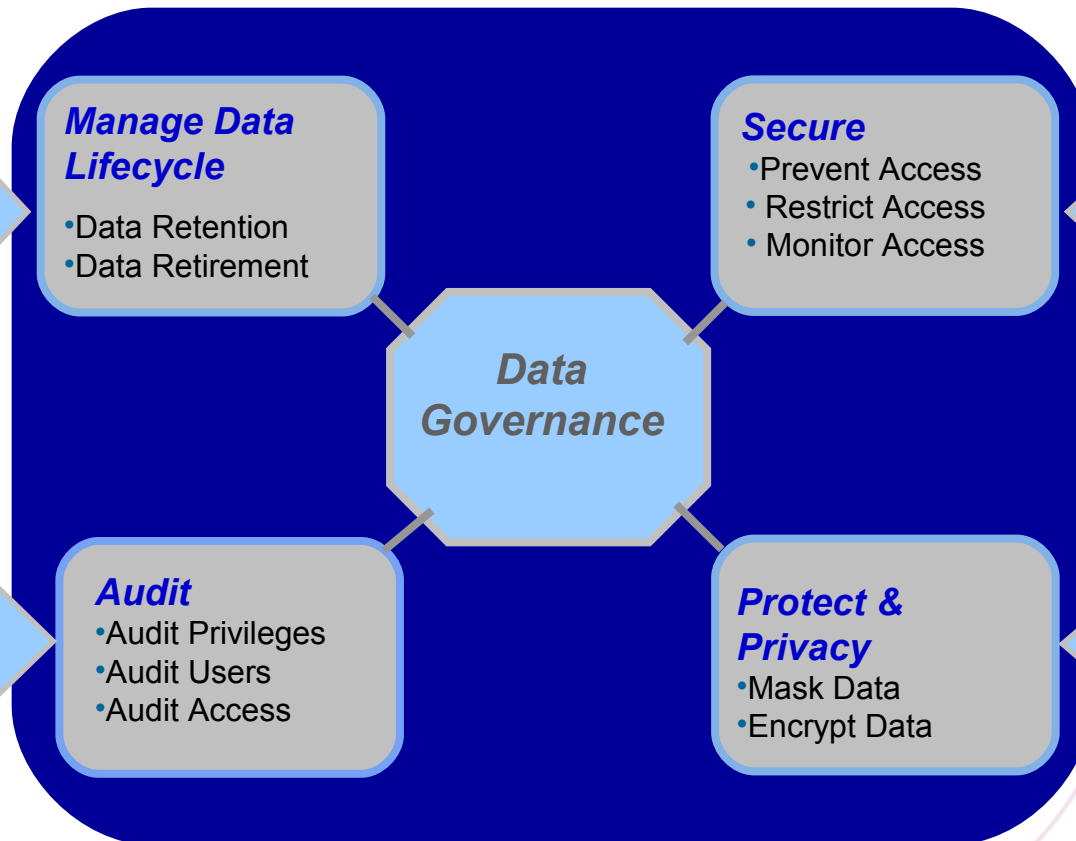

- Reduce risk from Security breaches

DB2/RACF Security
Tivoli zSecure Suite

- Protect sensitive customer and employee data

Data Encryption for IMS and DB2
Optim Test and Optim Data Privacy

IBM is the only solution provider with an end to end comprehensive solution

Data Warehousing and Business Intelligence





The Resurgence of Data Warehousing and Business Intelligence on System z

→ IBM has invested hundreds of millions of dollars to bring new state of the art capabilities and solutions to System z in support of customers' warehouse and BI requirements

- A 2007 study by IDUG found that nearly 50% of IDUG respondents are already using DB2 for z/OS for data warehousing. 78% indicated a desire for more capabilities in warehousing, query and reporting.

- *Analysts Agree!* IBM's Data Warehousing & BI breadth on System z is a game changer in the market.
Donald Feinberg, Gartner



Mission Critical Workloads Require Highest QoS

- **More than 90%** of Global 2000 companies plan to incorporate analytics into multiple operational applications that access the data warehouse by 2010, but fewer than 15% of data warehouses have been designed to provide high availability, failover, disaster recovery and the remaining components of mission-critical systems.
- By the end of 2009, **90% of Global 2000** companies will have implemented some type of mission-critical dependency between the warehouse and at least one revenue supporting or cost-controlling operational application — up from less than 25% in 2007.
- **Fewer than 15% of data warehouses** in 2007 have been designed to provide high availability, failover, disaster recovery and the remaining components of mission-critical systems.

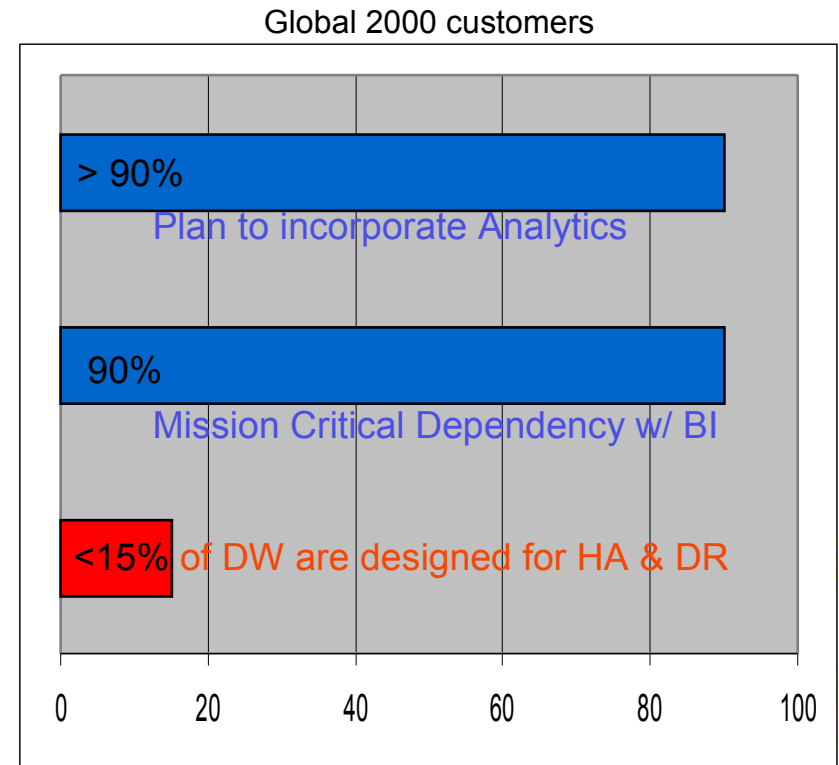

- Sounds like a good match for System z value proposition
 - Proven reliability and continuous availability capabilities
 - Exploiting synergistic effects of proximity to the operational data

¹ Operational Analytics and the Emerging Mission-Critical Data Warehouse, 14 May 2007



Why are customers moving to the strengths of System z for Data Warehousing and Business Intelligence?

Many System z customers already use System z for warehouse and BI

IBM is responding to customer demand with new DB2 features, new software offerings and improved hardware performance and efficiency.

Customers want to leverage their existing System z infrastructure

Costs can be reduced through the utilization of existing processors, people, Practices.

Cost savings may also be achieved through a consolidation approach.

New BI trends map well to the strengths of DB2 for z/OS and System z

Distinction is blurring between warehouse and OLTP databases due to new trends like Dynamic Warehouse and Operational BI, driving the need for:

- Increased reliability, availability, security, and compliance in a DWH
- Very current warehouse data and/or collocation of warehouse and operational data

Specialty processors and the new z10 provide additional ways to optimize TCO

zIIPs and IFLs are driving down hardware and software costs; DWH/BI can make excellent use of these processors, ultimately driving TCO advantages.

The new processors are delivering excellent speeds and feeds, making CPU horsepower less of an Issue.



DataWarehousing on system z – IBM at your service

- **Whitepaper** : Why Data Warehousing on System z available in the WEB
<http://www-306.ibm.com/software/data/db2bi/systemz.html>
- DW on system z – **Demo** available in the Technical Marketing Competence Center, Böblingen, Germany, TMCC@de.ibm.com
- DW on system z – **Customer Briefings** in the Executive Briefing Center at SVL or the Technical Marketing Competence Center, Böblingen, Germany
- DW on system z – **‘Redbook’** available

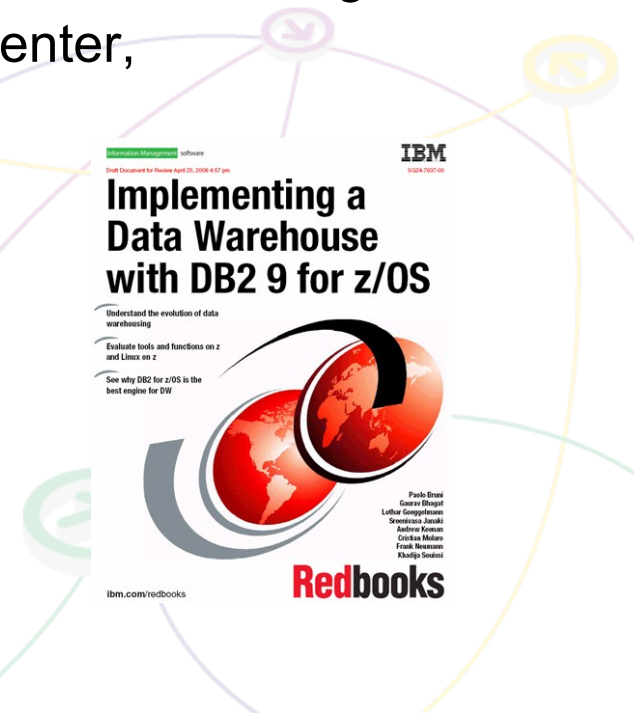

Data Integration



InfoSphere Information Server for System z

Accelerating the delivery of trusted information

**Profile, cleanse, and transform information
from heterogeneous data sources
to drive greater business insight**



IBM Information Server Unified Deployment



Unified Metadata Management

- Significant cost savings on System z
- Scalable to any volume and processing requirements
- Fully integrated, auditable data quality
- Metadata-driven integration for increased productivity

InfoSphere MDM Server for System z

The first multi-domain, multi-function MDM product in the market

→ Packaged to address all types of MDM implementations

- From small “registry” projects to strategic “transaction-hub” deployments
- Allows clients to grow as required by implementing existing functionality
- Significantly lowers client risk and time/cost to implement

→ Enables a SOA Library

- 800 pre-packaged business services
- Significant out of the box functionality
- Reduces total cost of ownership

→ Provides leading performance & scalability

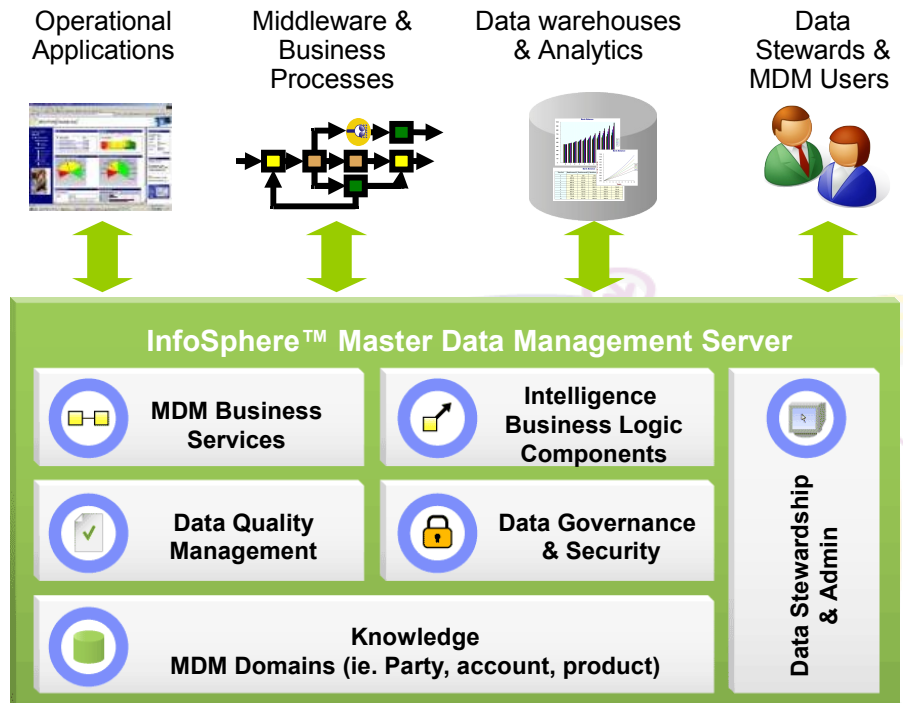

New! InfoSphere Warehouse on System z

Adds core data warehouse and analytics capability to DB2 for z/OS

- Advanced physical database modeling and design
- In-database data movement and manipulation capabilities of SQL Warehouse Tool (SQW)
- Optimize multidimensional reporting and analysis of data with Cubing Services

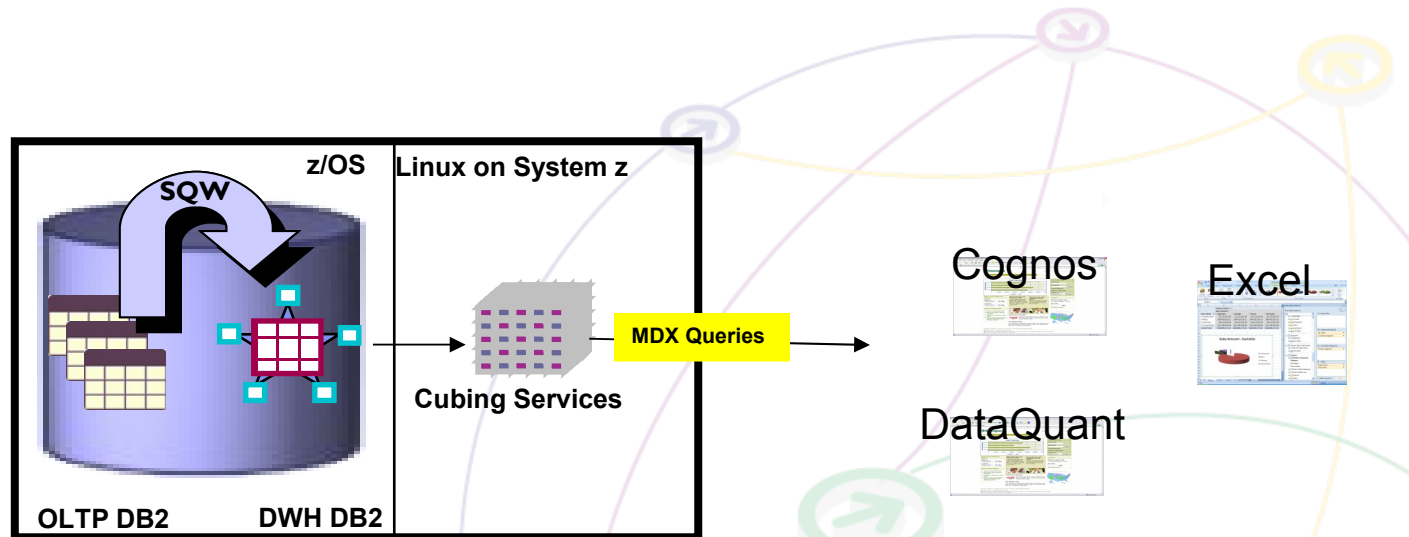

[System z Environment Enhanced with InfoSphere Warehouse](#)

The window to the Information



Built on an SOA to deploy successfully within changing environments

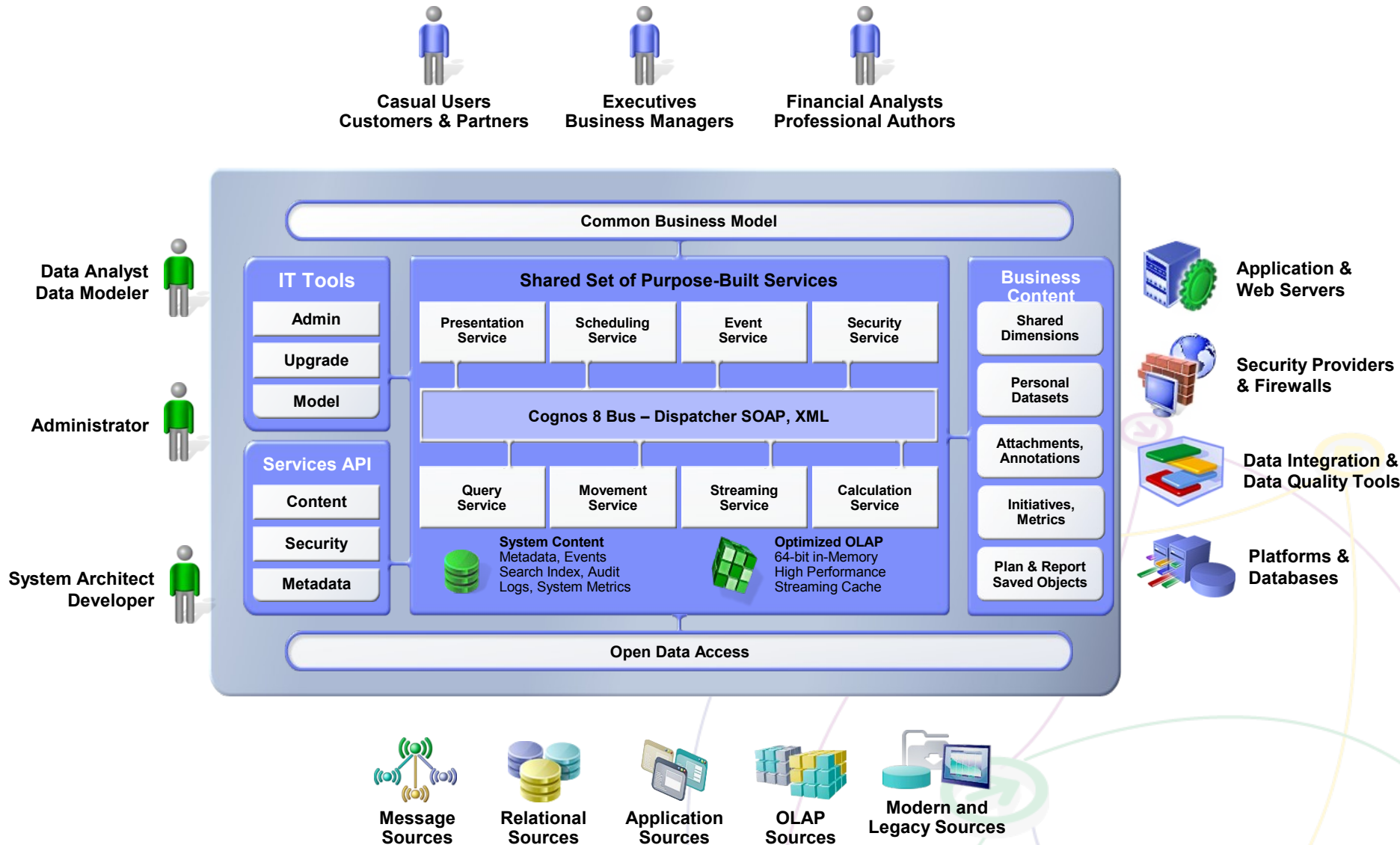

The IBM Cognos 8 platform

PRESENTATION TIER

Broad Range of Capabilities

APPLICATION TIER

Common Set of Services

Common Metadata layer

DATA TIER

Open Data Access

(Transactional, Warehouses or Modern data sources)

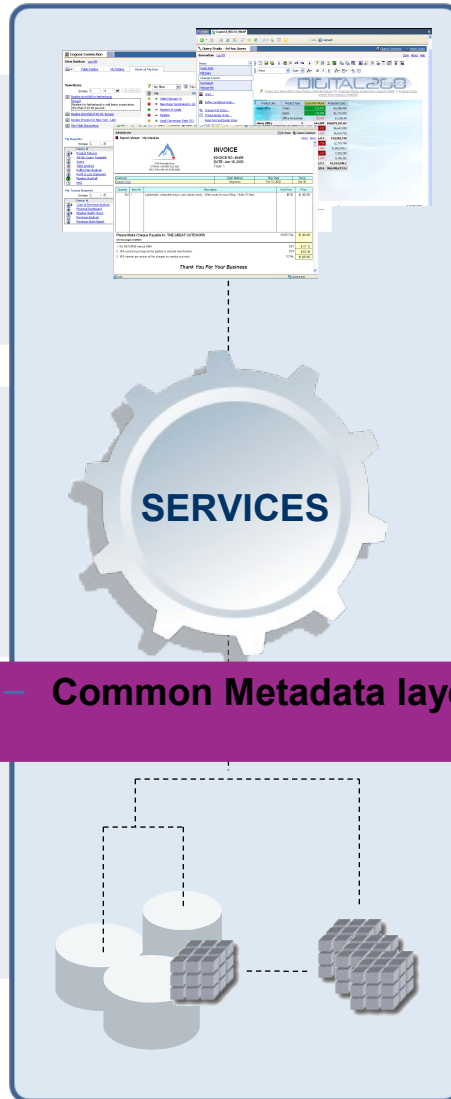



Why Cognos 8 BI for Linux on System z?

- **New workload is moving to System z**
 - Leveraging the platform strengths to improve performance, scalability, reliability, availability, bullet-proof security and energy-saving capabilities of the mainframe
- **Customers are requesting the complete IM portfolio on System z**
 - They want their middleware software running as close to their transactional data as possible
 - To take advantage of a single point of control
 - For close access to data hosted and accessed on System z
- **Benefits of running IBM Cognos 8 BI for Linux on System z**
 - With a BI solution on the same platform as the operational data, customers can reduce the time to access critical operational data which is the foundation of their businesses.
 - IBM Cognos 8 BI for Linux on System z is built on the open Cognos 8 platform so customers can now combine the enterprise-class Cognos 8 platform with the z platform

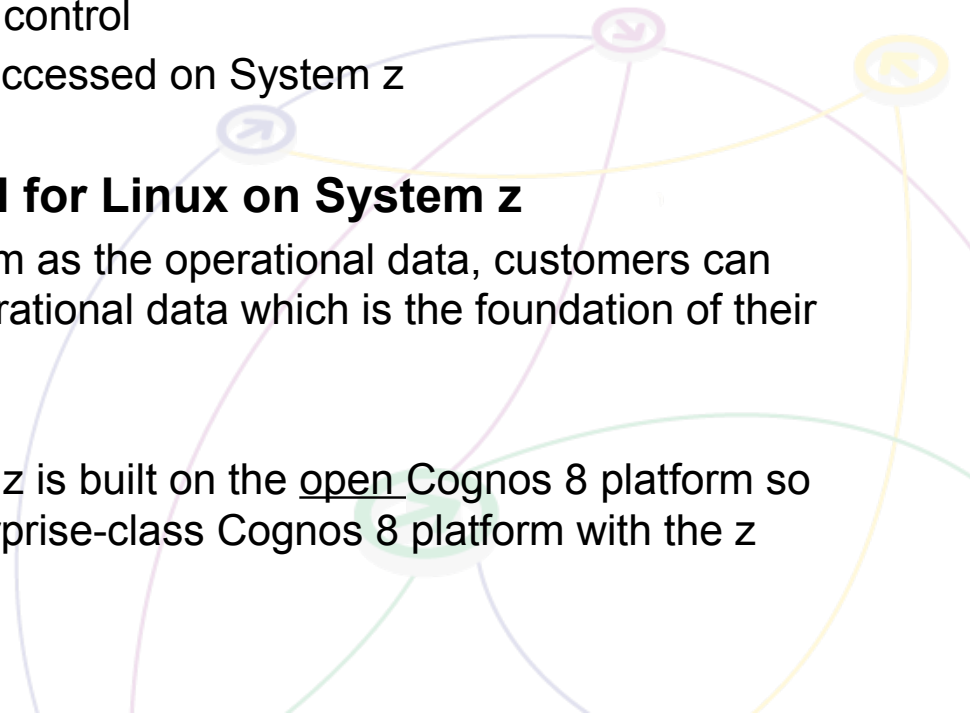



IBM System z

Proven that Cognos 8 BI for Linux for System z can: Scale Across the Enterprise

Testing demonstrated IBM Cognos 8 BI for Linux on System z **scales linearly** to large user groups.

Linear Scalability
IBM Cognos 8 BI for Linux on System z

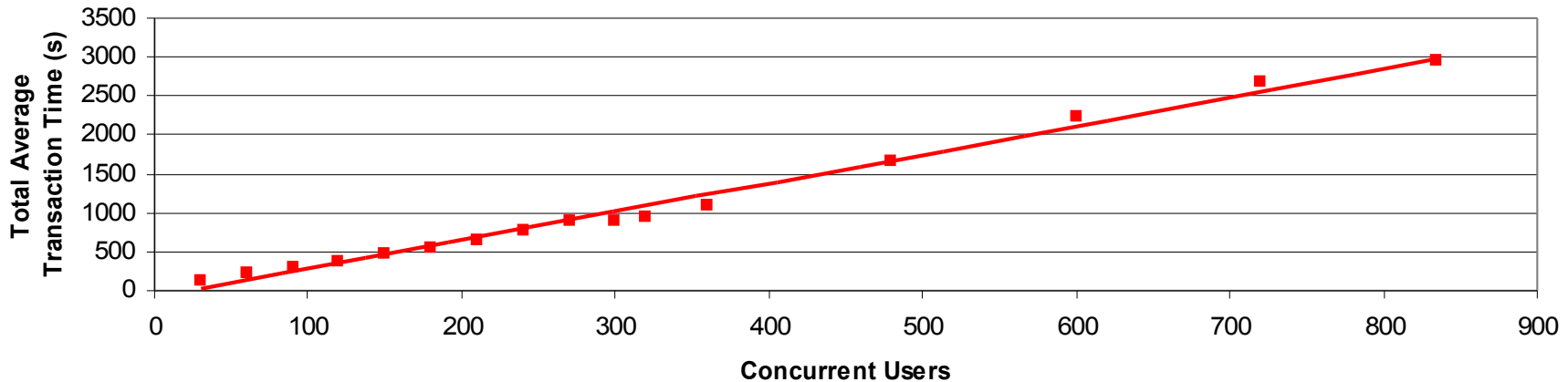

“Cognos, ...makes it easy for companies to deploy BI and PM to a broader user population, while minimizing the resulting workload for IT departments.”

- Nucleus Research, Cognos Takes on the Rest of the Enterprise, November, 2007

■ Testing was conducted on up to **90,000 named users**



Numius Case Study

→ Numius tested an existing customer's distributed Cognos environment on System z

- The application was successfully and without loss of functionality ported to the System z platform. This required no redevelopment.
- The client's application would not require a redesign to accommodate its growth in data volumes or in terms of users.
- Reports that are not practically useable at client's site now become relevant again. Reports that did not run at client's site now are runnable.
- Client would be able to serve many multiples of current number of users with the very simple architecture from this PoC.
- Client could scale out to more complex architecture without increased hardware complexity.
- Throughput (not clock speed) 400x that of distributed

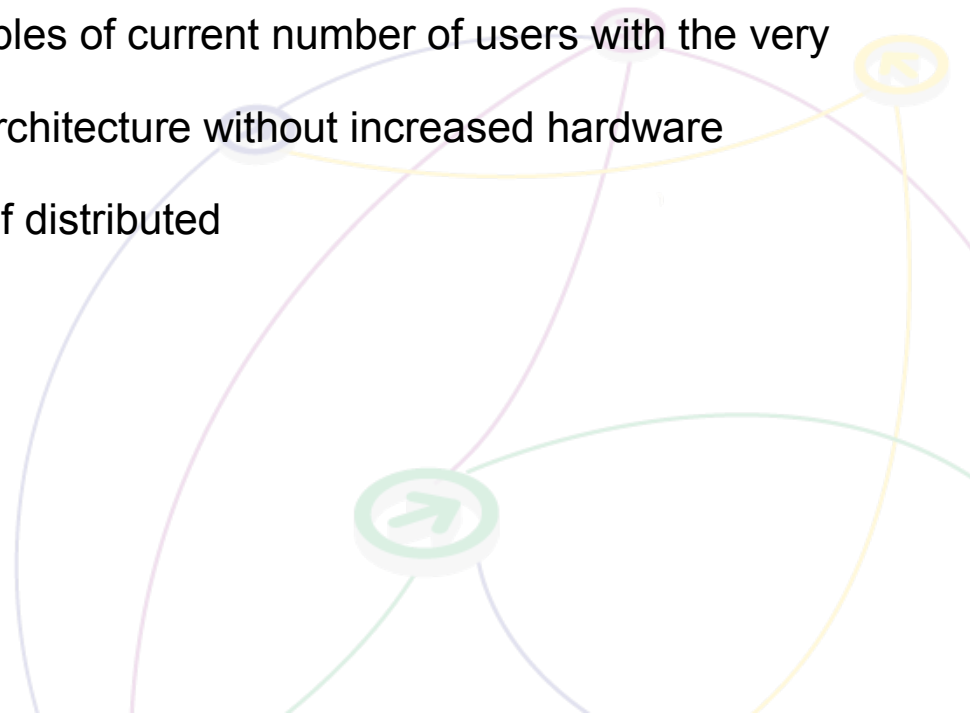



IBM Smart Analytics Optimizer

Technology Preview for System z



Client Need:

Fast and predictable query response time on unpredictable workloads

Lower cost

Better price / performance

The IBM Smart Analytics Optimizer:

Capitalize on data in existing systems by improving performance of typical analytic queries by an order of magnitude

Dramatically reduce administration efforts by reducing the need for database tuning

Significantly improve price/performance with workload optimized software and hardware



IBM Smart Analytics Optimizer Technology Preview for System z

What is it?

- ✓ A high performance extension that easily integrates with IBM data systems, delivering predictable, order-of-magnitude faster, analytic query response times, while lowering operating costs



How is it different

- ✓ **Deep integration with IBM data management systems**
- ✓ **High performance query software, based on advanced data in-memory technologies**
- ✓ **Leveraging existing data system investment and values without any changes to applications**
- ✓ **For System z, extends gold-standard manageability, security, and availability to high-performance analytic applications**



The Data Warehouse and BI Solution on System z

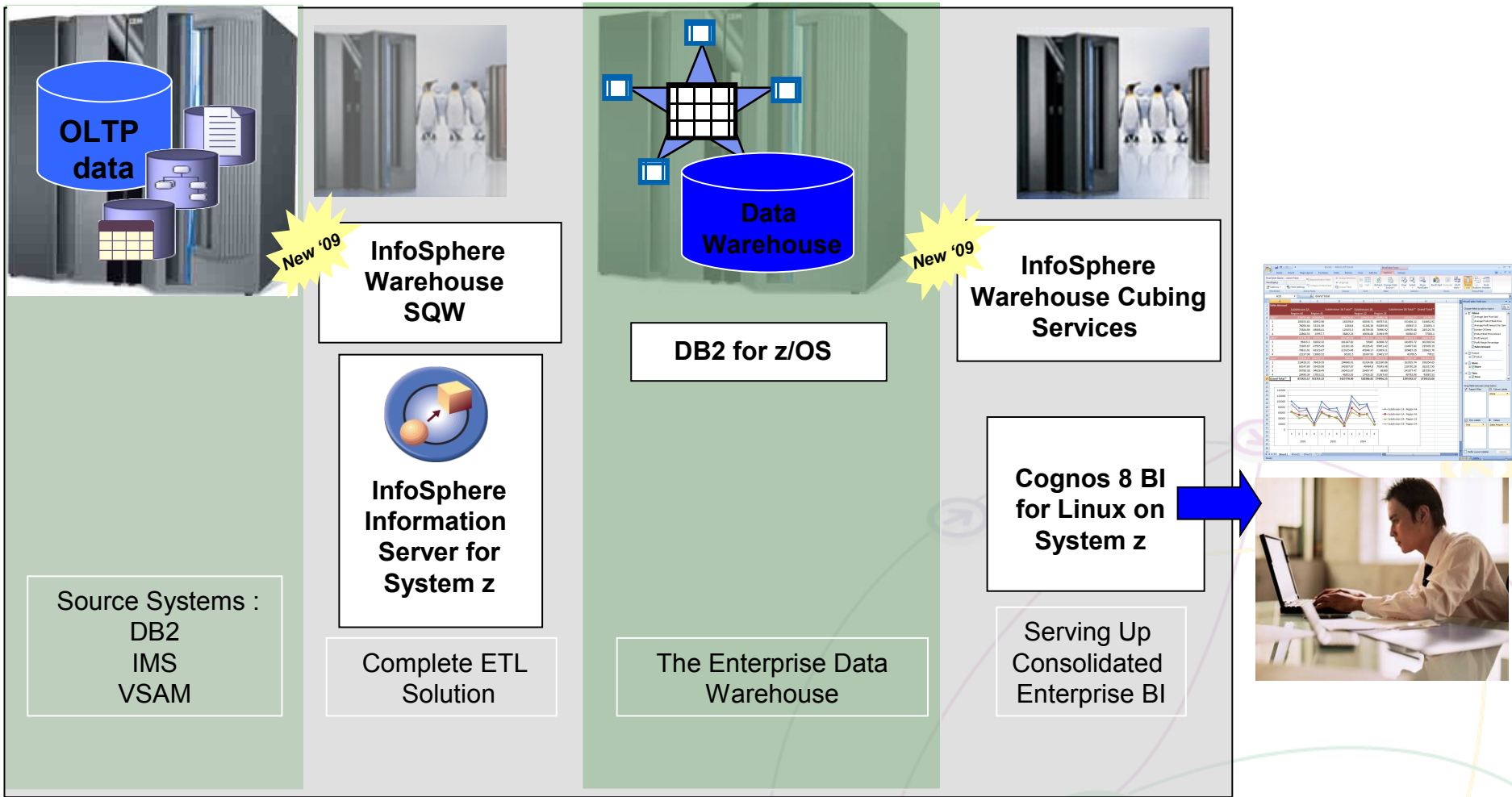

Combining the Reliability and Availability of DB2 for z/OS with Cost Effective Applications running on Linux for System z



Announcing the new System z Solution Editions:

Legendary Mainframe quality, price-competitive with distributed systems which may not be as highly available, reliable, scalable and secure as an IBM System z:

- *Affordable complete stack solutions*
- *Includes IBM System z hardware and Maintenance, IBM Middleware and IBM Services programs for new business functions*
- *Modeled on the successful “SAP Solution Edition” for which IBM has experienced significant growth*
- *Rapid, optimal and cost effective development*
- *Help make mainframe deployment of new workloads affordable, simple, and accessible*

Solution Editions include:

- *Data Warehousing*
- *Security Hub*
- *WebSphere SOA Hub*
- *Application Development*
- *SAP server*
- *ACI Payments Solutions*
- *GDPS DR & HA*
- *Cloud Services Solution*

What: Smart Analytics Cloud

A private cloud optimized for analytic services in large enterprises

Defined as ...

To create...

That delivers ...

Smart Analytics Cloud

IBM Smart Business - services with industry leading hardware & software

A private cloud computing solution for business intelligence (BI) & analytics

A services solution for delivering business intelligence to the entire organization

IBM software

Cognos 8 BI

A broad range of BI capabilities

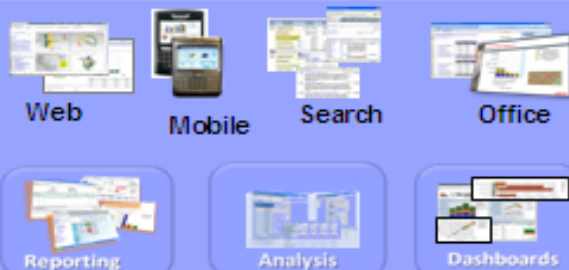

Open, enterprise-class BI platform

IBM hardware

IBM System z

Centralize, Virtualize & Simplify the BI infrastructure



IBM Services

- Create awareness of BI and understand the needs for a BI strategy across the organization
- Complete a readiness assessment to define the scope and priorities for the solution
- Deploy Cognos 8 BI for Linux on System z as a private cloud
- Provide the skills for the on going management & expansion of their BI private cloud deployment





Summary





A Multitude of Information Projects

Each successful in its own right; but limited speed and flexibility...

Large Global Bank

- 5 data warehouse projects in 5 years
- Large customer call center deployment
- Reengineered CIF System
- Millions invested



“I still can’t sleep at night;

I don’t have a real time and accurate view into my risk posture” - Chief Risk Officer

“I still can’t tell you who our most profitable customers are, let alone serve them well across my channels” - Chief Information Officer

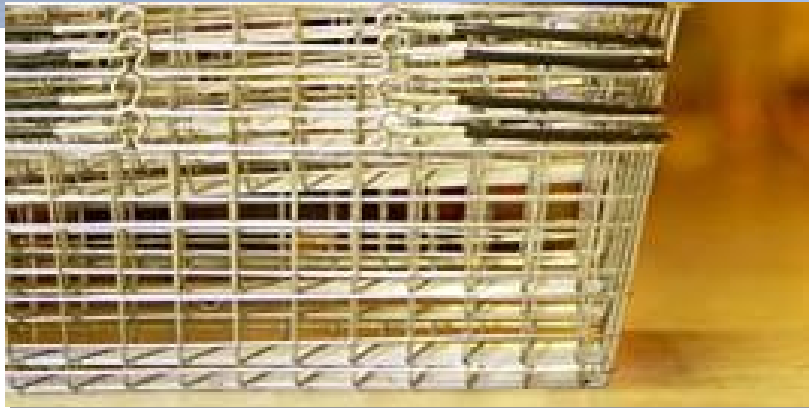

Multi-channel Apparel Retailer

- 3 brick & mortar and 1 web channel
- Multiple customer loyalty systems
- Multiple call centers
- 1 credit card



Becoming an Information Based Enterprise...

Information Agenda: The 5th entry point of Information On Demand

Creating an information agenda helps transform information into a trusted strategic asset that can be rapidly leveraged across applications, processes and decisions for sustained competitive advantage.

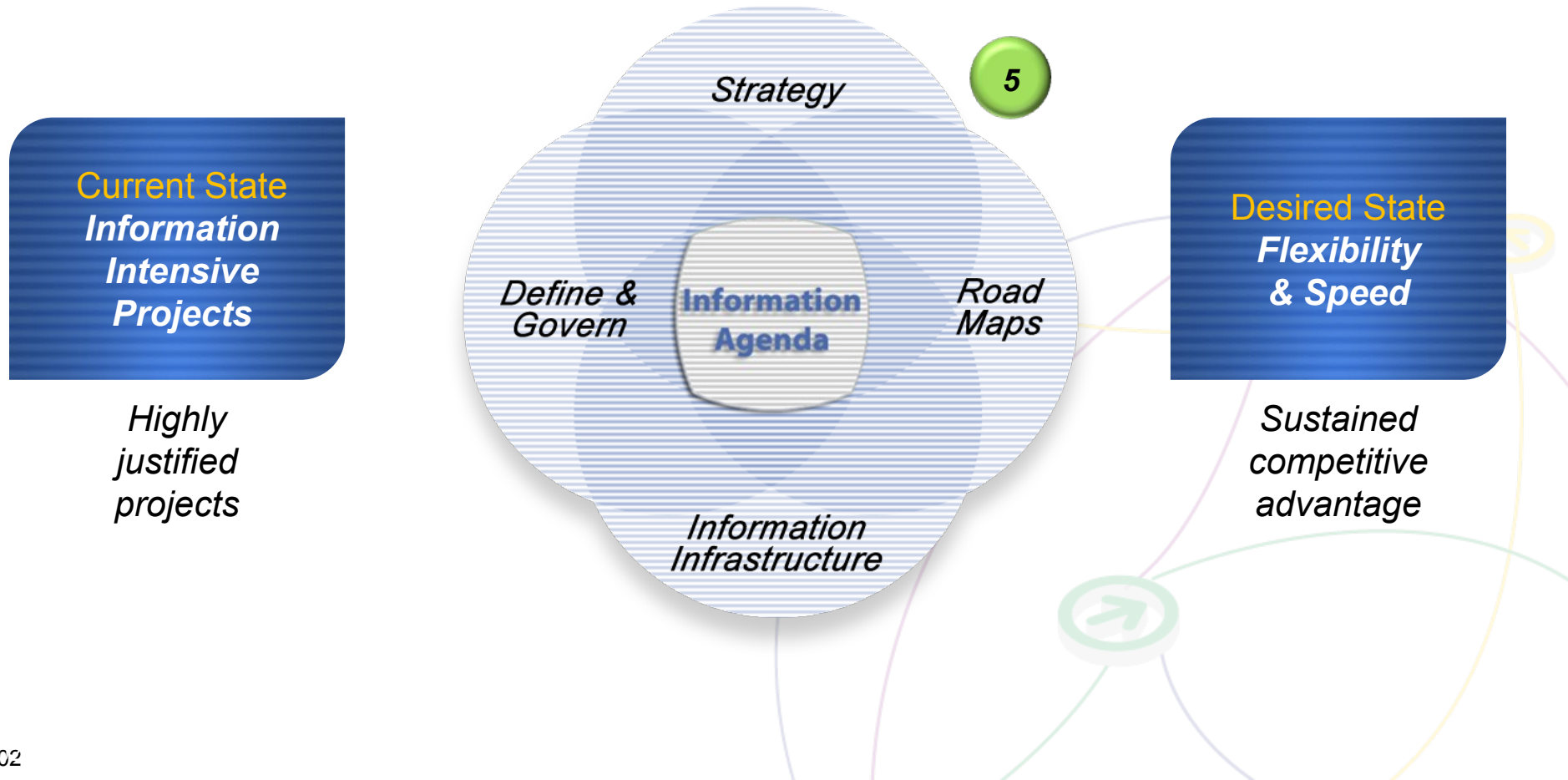



Accelerating Your Information Agenda

Recent Announcements result from \$1B+ investment & experience from thousands of client projects

New

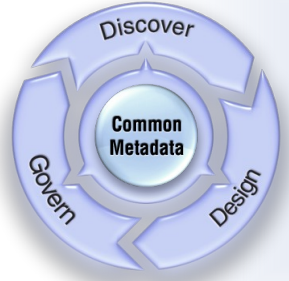

Foundational Tools

Software to help you convert your information into a trusted strategic asset

New

Information On Demand Competency Centers

Services to help you build information centers of excellence

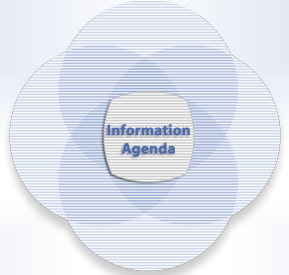

New

Information Agenda Guides & Workshops

Industry tailored sessions to guide future state design, identification of key information requirements and gap analysis

New

Information Accelerators

Industry specific assets to speed deployment

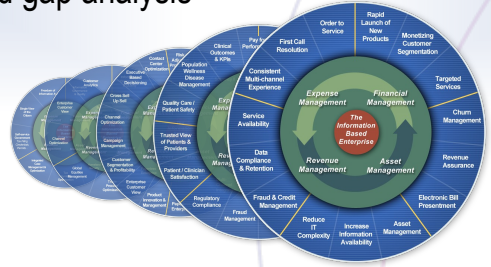



Typical Utilization for Servers

Windows: 5-10% Unix: 10-20% **System z: 85-100%**

System z can help **reduce** your floor space up to **75%-85%** in the data center



Thank You

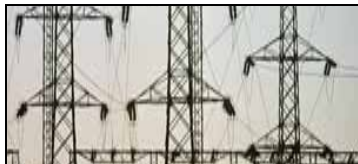

System z can lower your total cost of ownership, requiring **as little as 30%** of the power of a distributed server farm running equivalent workloads

The cost of storage is typically **three times more** in distributed environments

