



Akademia Lotus Software 2010

10-12 marca 2010, Zakopane

Nowe wcielenie Lotus Sametime

Rafał Skirzyński, IBM



Co się zmieniło?

- Nowa forma spotkań
- Poprawiona jakość wideo
- Nowe wersje przeglądarkowe
- Wiele, wiele innych...



Lotus Sametime® 8.5

Lotus Sametime® 8.5

Co się zmieniło?

- Całkowicie przepisane webkonferencje
 - Szybsze uruchamianie i obsługa
 - Gruby klient - Sametime lub Notes
 - Przeglądarki www
 - Bez potrzeby rezerwacji
 - Spotkania ad-hoc i trwałe pokoje konferencyjne
 - Poprawiona integracja z kalendarzem Lotus Notes (i Microsoft Outlook)
 - Poprawiona jakość współdzielenia ekranu
 - Łatwe nagrywanie i odtwarzanie (pliki .MOV)
- Poprawiona niezawodność konferencji
 - HTTP/HTTPS zamiast T.120
 - Ułatwiona konfiguracja firewall/SSO itd.
 - Wbudowane mechanizmy failover i lokalizacji geograficznej
 - Nie trzeba już EMS

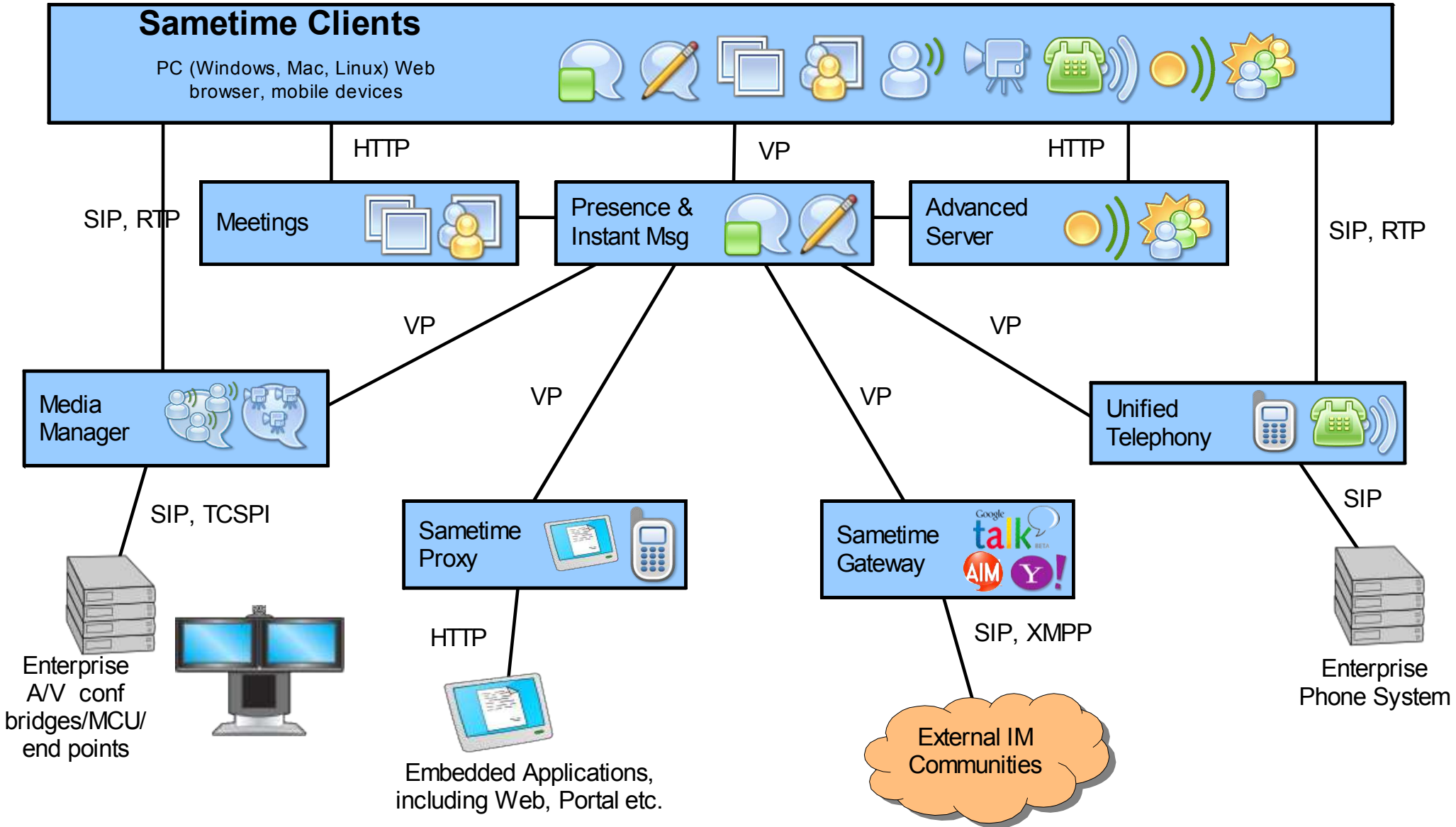

Spotkania

Gruby klient

- Sametime Connect lub wbudowany w Notes
- Szybkie tworzenie spotkań
- Nie trzeba się ponownie logować
- Drag and drop
- Audio video

Klient przeglądarkowy

- Nie trzeba nic instalować
- Dla użytkowników zautentykowanych i gości
- Applet do współdzielenia ekranu

Spotkania – ST Connect

- “Gruby” klient potrzebny jest do:
 - Konwersji slajdów po stronie klienta
 - Zdalnej kontroli aplikacji / pulpitu
 - Drag/drop dla dodawania osób do spotkаний
 - Drag/drop dla dodawania treści
 - Nagrywania spotkań
 - Narzędzi edycyjnych
 - Ankiet
 - Zrzutów ekranu
 - Audio/Video

Audio i Video - aktualne

Sametime Voice/ Video Chats

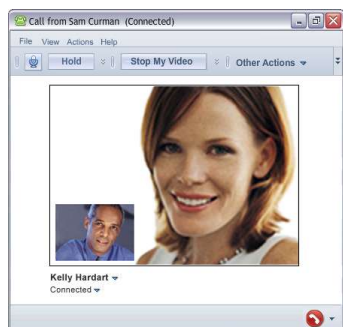

Sametime 8.5



Sametime Meetings



- IBM Sametime 8.5 client
 - Wsparcie dla chatu, VoIP audio/video chats & online meetings
 - Wykrywanie aktualnego prelegenta
 - Kodeki
 - ▶ H.263, **H.264**
 - ▶ G.711, **G.722.1**, iSAC, iLBC
 - Klient wspierający SIP
- IBM Sametime 8.5 Media Manager svr
 - SIP proxy registrar
 - Wsparcie dla SIP
 - Media router (packet switcher)
- Pozostałe
 - Sametime Community server
 - ▶ Dostępność i czat
 - Sametime 8.5 Meeting server
 - ▶ Konferencje ad-hoc i trwałe
 - ▶ Udostępnianie pulpitu/aplikacji

Audio i Video - aktualne



Sametime voice & video calls

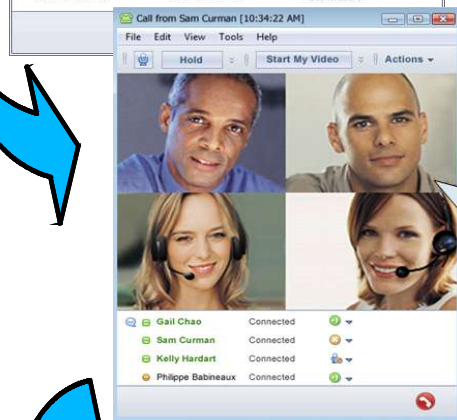
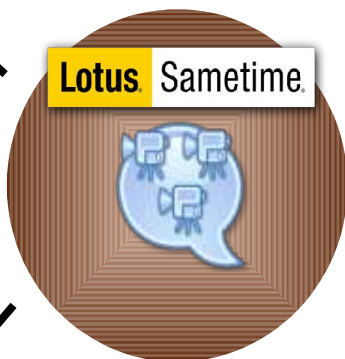

Sametime Meetings



Telepresence



Room Video Conferencing systems



Partner delivered connectors

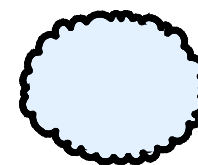

H.323
ISDN



Rozwiązania partnerskie

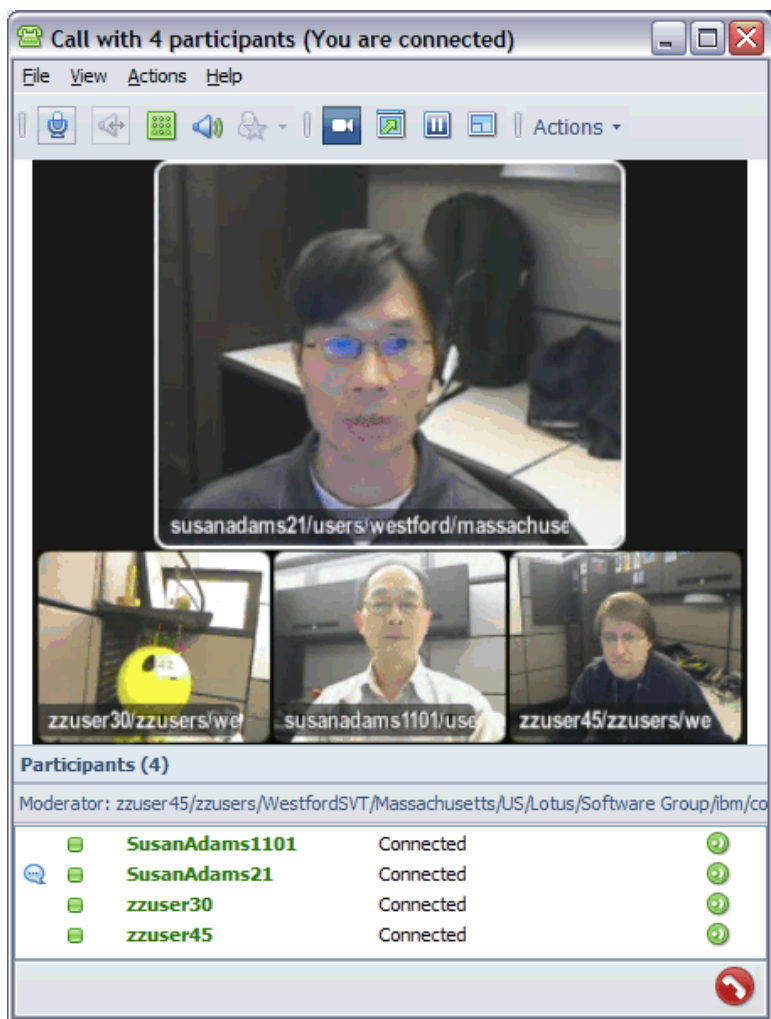

Klient

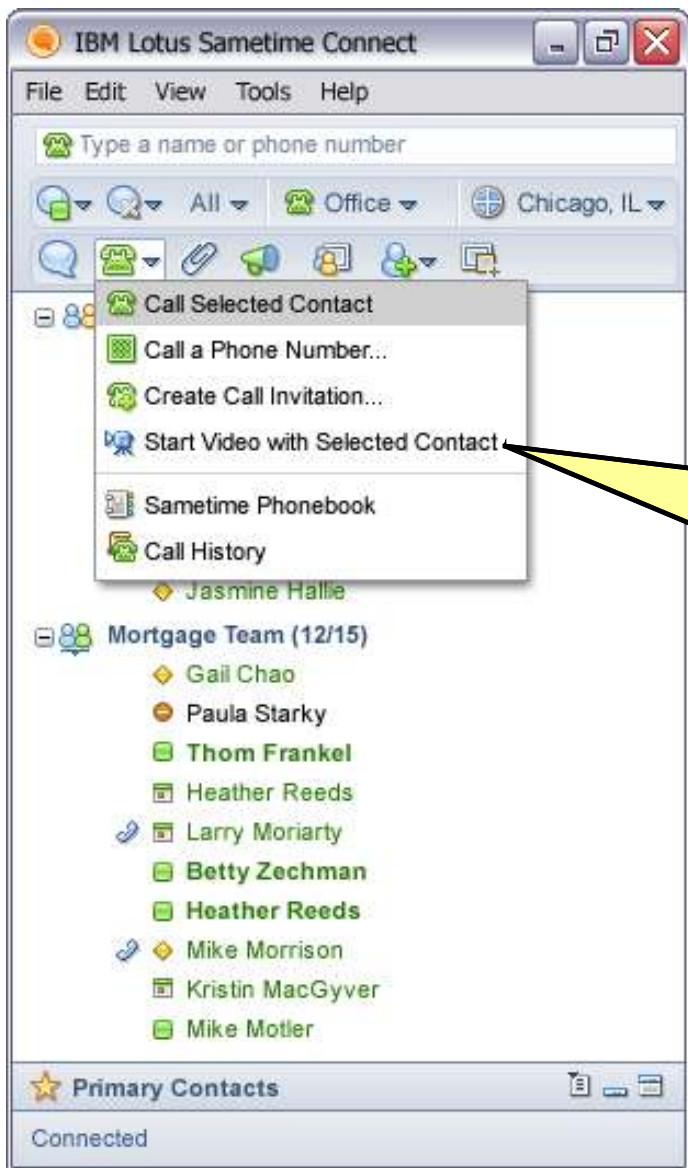

Prawie identycznie jak w Sametime 8.0.2

Możliwość wybrania wielu osób do rozmowy wideo

Wideo w kliencie



Zmiana rozmiaru
 Full screen
 Możliwość ukrycia własnego wideo

Lotus Sametime® 8.5

Spotkanie - audio

Join Call

- Join with my telephone...
- Join with my computer (This is a video-enabled session)

Participants:

- Sam Curman
- Kelly Hardart
- Philippe Babineaux
- Amadou Alain
- Betty Zechman

Library

- Organizational_Chart.odp
- Share Download
- Weeklymeetingnotes.odp
- Legaldiscloser.odp
- http://www.renovations.com
- Image_2089.jpg
- Meetingnotes.txt
- RenovationsTea....png

Group Chat

Call Controls: Raise Hand, Record, [Icons]

Click to join audio

Możliwość skorzystania z audio:

1. Wbudowanego, Sametime zawiera VoIP audio, lub
2. Rozwiązania sprzętowego poprzez conference bridge adapter (wzwanie przez telefon)

Spotkanie – audio i wideo

The screenshot shows the Lotus Sametime Web conferencing interface. A yellow callout box labeled "Kontrolki wideo" points to the video control icons (mute, video off, video on) in the top toolbar. Another yellow callout box points to the "Participants - 6" list, which includes names like Gail Chao, Sam Curman, Kelly Hardart, Philippe Babineaux, and Amadou Alain. A green button labeled "Click here to share" is visible in the center of the main video area. A large yellow callout box on the right explains the participant list: "Lista uczestników : Aktywny prelegent Status Status wideo – kto aktualnie mówi". The bottom of the interface shows a "Group Chat" section, "Raise Hand" and "Record" buttons, and a status bar indicating "This meeting is being Recorded".

Sametime w przeglądarce

- Statusy dost?pno?ci
- Lista kontaktów
- Dodawanie / usuwanie kontaktów
- Wyszukiwanie
- Wizytówki
- Po?b?enie
- Czat 1 do1
- Czat wiele do wielu
- Og?oszenia
- Rich text
- Emotikony
- Konferencje b?yskawiczne
- Nowe api

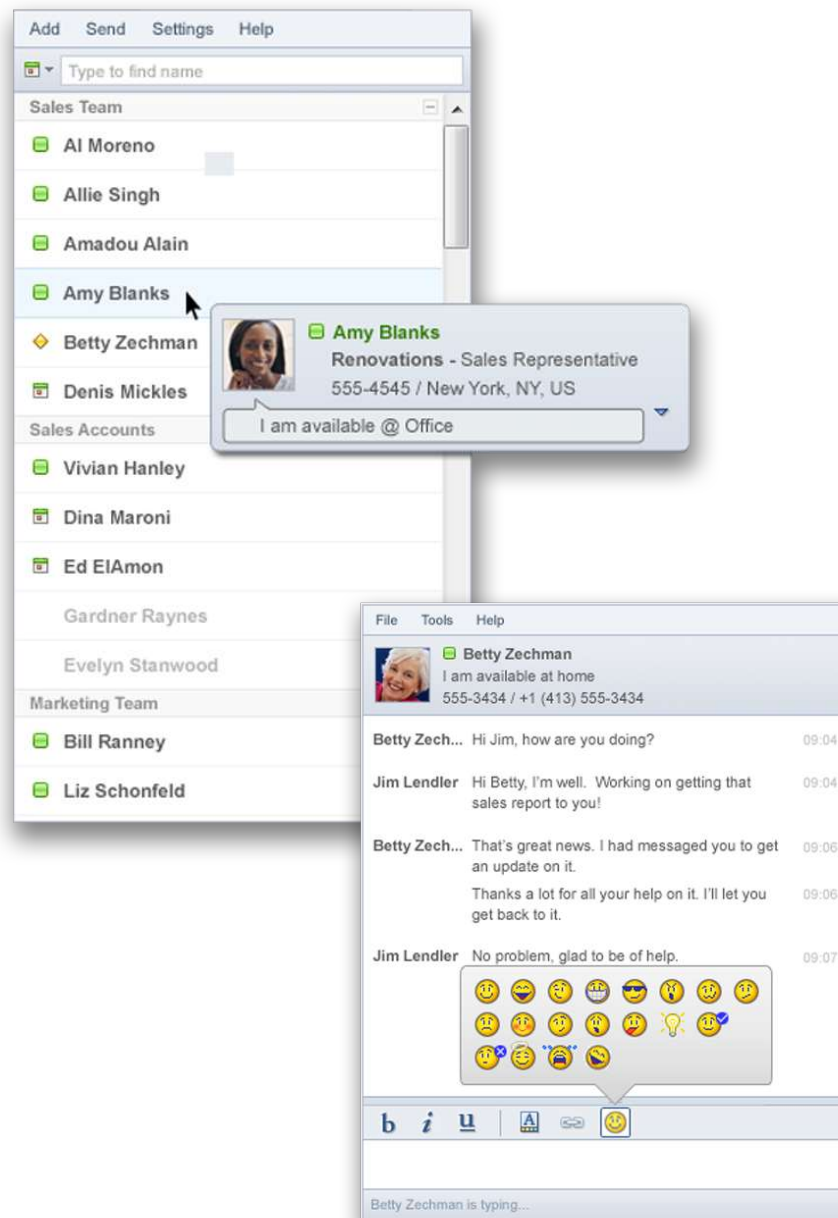

Lotus Sametime® 8.5

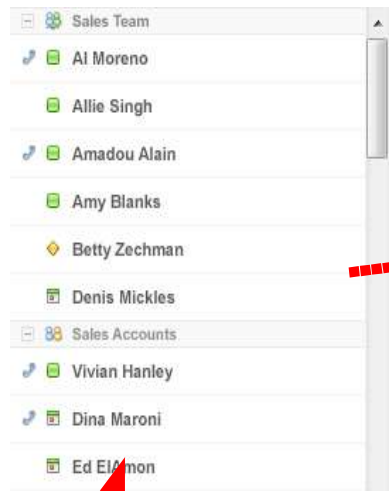

Buddy List

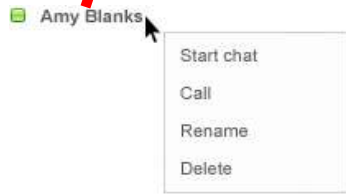

Livename

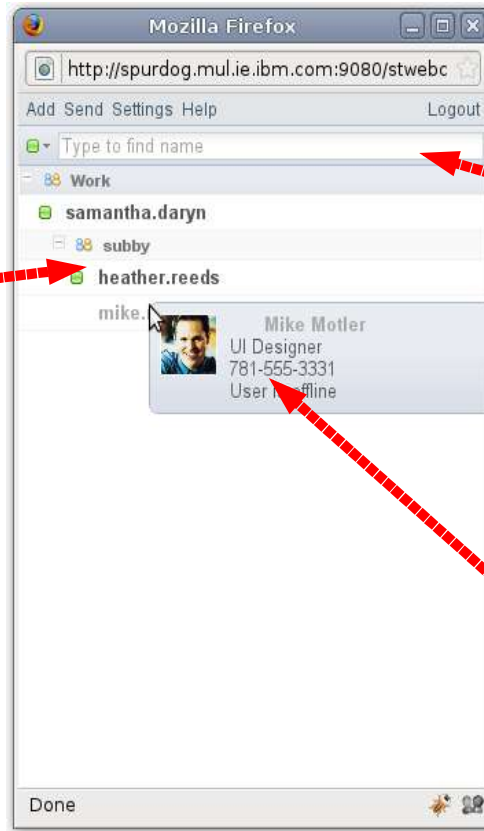

Pre-made client

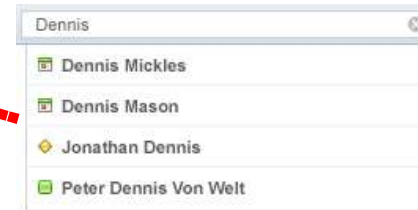

Quickfind



Business card

API dla www

OPEN FINANCIAL NETWORK Home | Wholesale Banking | Home | More... Frank Adams | Edit my Profile | Help | Log Out

Home Blogs New Page Add Content Change Theme Share Page

News

- New Market Trends for 2009** Nov 18 | Sam Omie
- Working with Teams Nov 16
- Market Research Nov 14
- Company Benefits Update Nov 14
- Cost Analysis - Renovations Green Nov 12
- Best Finance Software 2008 Nov 12

Subscriptions Updates

Blogs See more

- Renovations Finance Plan** Sam Curman | Jan 04, 2009 Details
- Global Finance** Gail Chao | Jan 10, 2009 Details
- IT for Finance Teams** Gail Chao | Jan 10, 2009 Details

Team Places Updates

- Marketing Collateral** Brochure.pdf - Amadou Alain Jan 04, 2009 | Details
- Renovations Finance Team** Brochure.pdf - Amadou Alain Jan 04, 2009 | Details

Mail

Sort By Date

- ★ **Sam Curman** Renovations Financial Planning 01/17/09 4:45 PM
- ★ **Gail Chao** Re: Renovations Financial Planning 01/17/09 4:45 PM
- ★ **Gail Chao** Cost analysis 01/17/09 4:45 PM
- Glenn Cloud Here are the estimates for the OFN brochures 01/17/09 4:45 PM

My Objectives

Performance Update

- Reduce Costs** 40% (Progress bar: 0% to 100%, current at 45%)
- Increase Credit Lines** 30% (Progress bar: 0% to 100%, current at 55%)
- Implement Customer Retention Programs** 90% (Progress bar: 0% to 100%, current at 75%)

Activities

1 - / of 20 Previous Next

- Finance Charts Templates for 2009** updated by Sam Curman Today 9:30 AM More
- Renovations Budget Discussions** updated by Sam Curman Today 9:30 AM More
- Marketing Materials** updated by Gail Chao Today 9:30 AM More
- Greenworld Conference Preparation** updated by Sam Curman Today 9:30 AM | DUE JAN 21 More

Day at a Glance

Wed, November 14, 2009

Mel & Michelle's Anniversary

- 10:00 AM - 11:00 AM** Marketing Meeting Gail Chao
- 11:00 AM - 12:00 PM** Product Analysis Update Sam Curman

Colleagues

- Customer Relations
 - Ed ElAmon
 - Gardner Raynes
 - Jasmin Haj
- Finance Experts
 - Dennis Mickles
 - Sam Curman
 - Heather Reeds
 - Ling Shin
 - Lucille Suarez
 - Betty Zechman

Tools

- Expense Reimbursement
- Benefits Enrollment
- Human Resources

Klient przeglądarkowy - style

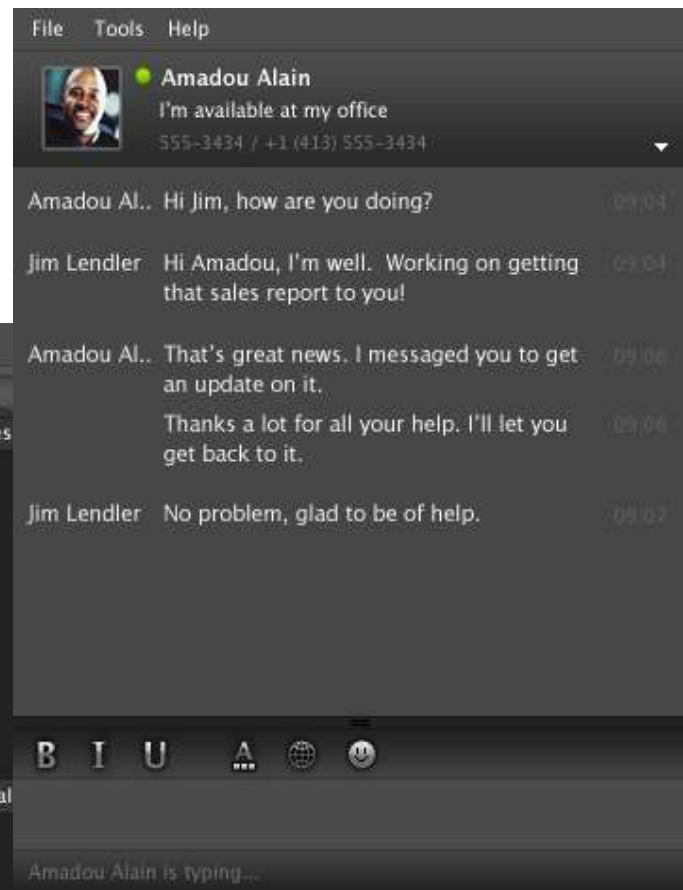
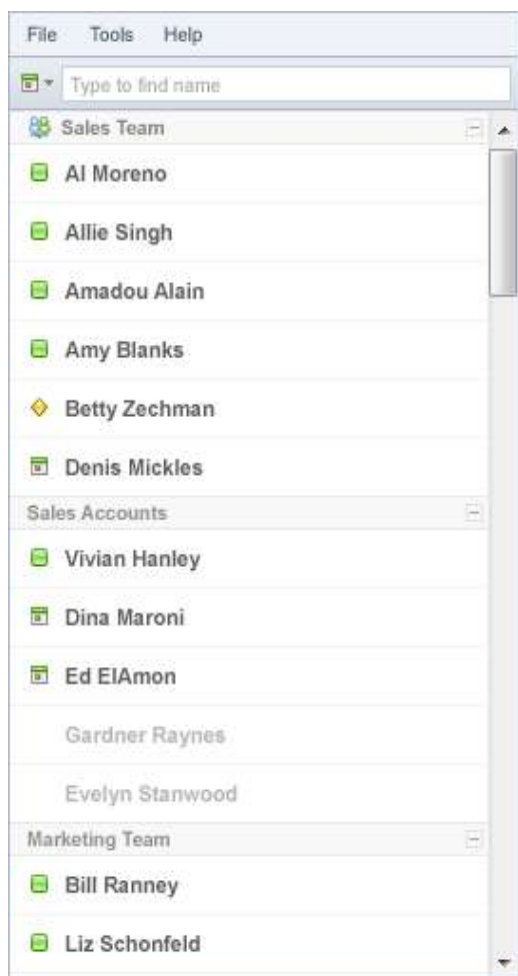

Lotus Sametime® 8.5

iPhone



Integracja z MS Outlook

Nowy toolbar - click to talk, wyślij plik, ogłoszenia, konferencja błyskawiczna...

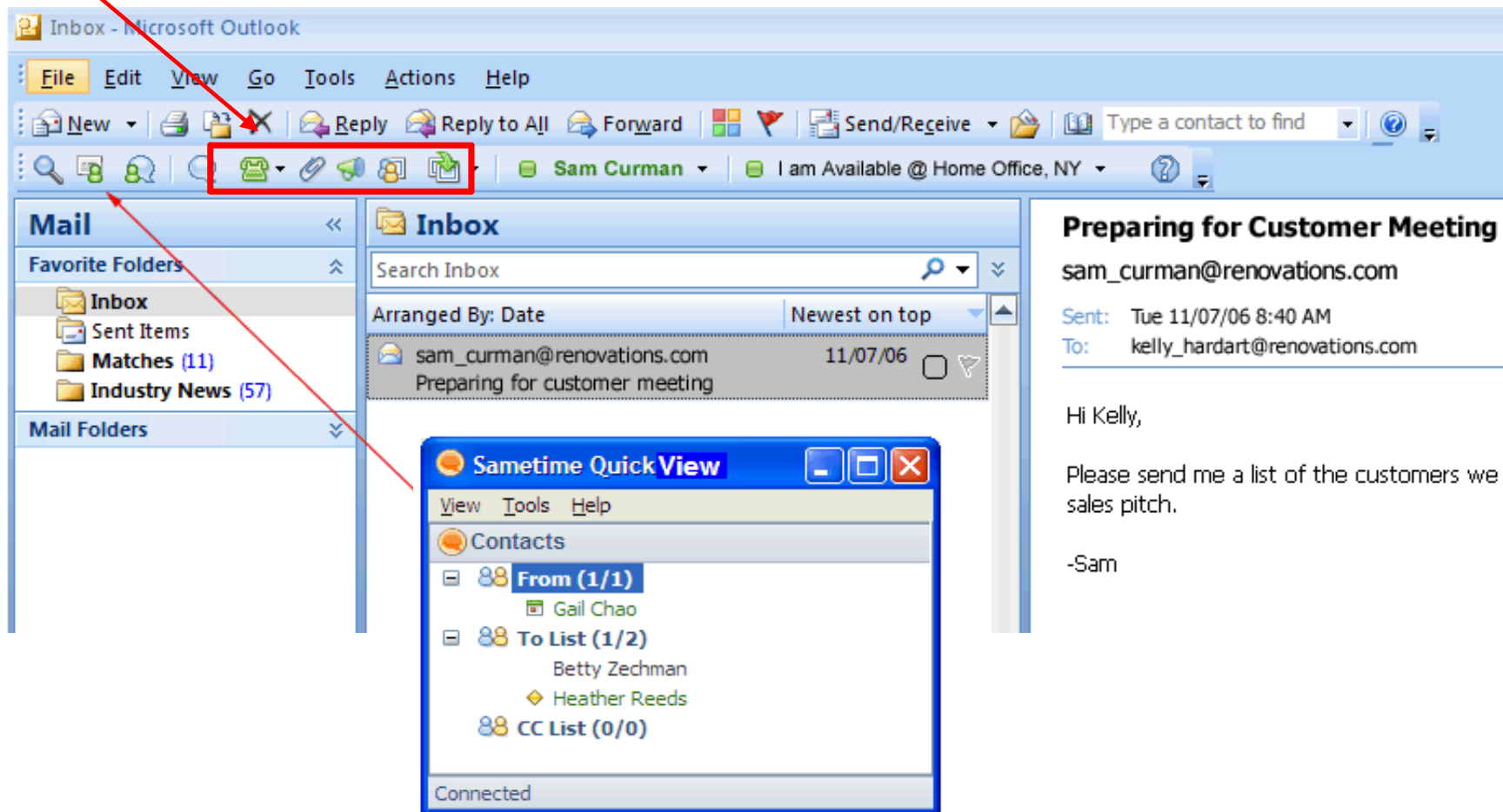

System Console - przykład

Manage Policies

View, modify, and assign policies to users and groups. To assign a policy, select the policy and click Assign. To view the policies currently in use for a particular user, click Find Active Policies.

All unauthenticated users will have the Anonymous Policy applied to them. For authenticated users, the policy engine will search for an exact user ID match, and then apply the highest weighted policy. If there is no match for the user ID in any policy, then the policy engine will apply the highest weighted group match. If no group matches are found, then the default policy will be applied.

Instant Messaging Meetings Media Manager

New... Edit... Delete Duplicate... Assign... Find Active Policies... Move Up Move Down

Name	Weight
<input checked="" type="radio"/> Sametime Meetings Default Policy	1
<input type="radio"/> Sametime Meetings Anonymous Policy	0

Manage Policies

Meetings > Edit Policy
Specify settings for this policy to give access or limit access to a feature.

Policy Name: **Sametime Meetings Default Policy**

General Meeting Settings

Maximum persistent meeting rooms this user can own:

Set this value to zero to prevent the user from creating any persistent rooms.

Allow user to create instant (non-persistent) meeting rooms

Automatically connect to meeting server when logging into Sametime Connect (IC)

Allow searching for meeting rooms
 If unchecked, users can attend meeting rooms only via a direct URL. The meeting room manager UI will never display.

Allow searching for hidden meeting rooms
 If unchecked, hidden rooms will never be returned in search results. If checked, users can explicitly search for hidden rooms by exact name.

Show "Scheduled Meetings" view (IC)

Allow meetings to be recorded (IC)

Allow meeting room content to be downloaded

Installation Manager

- Zintegrowany z Sametime System Console
- Wspierany też typowe instalacje

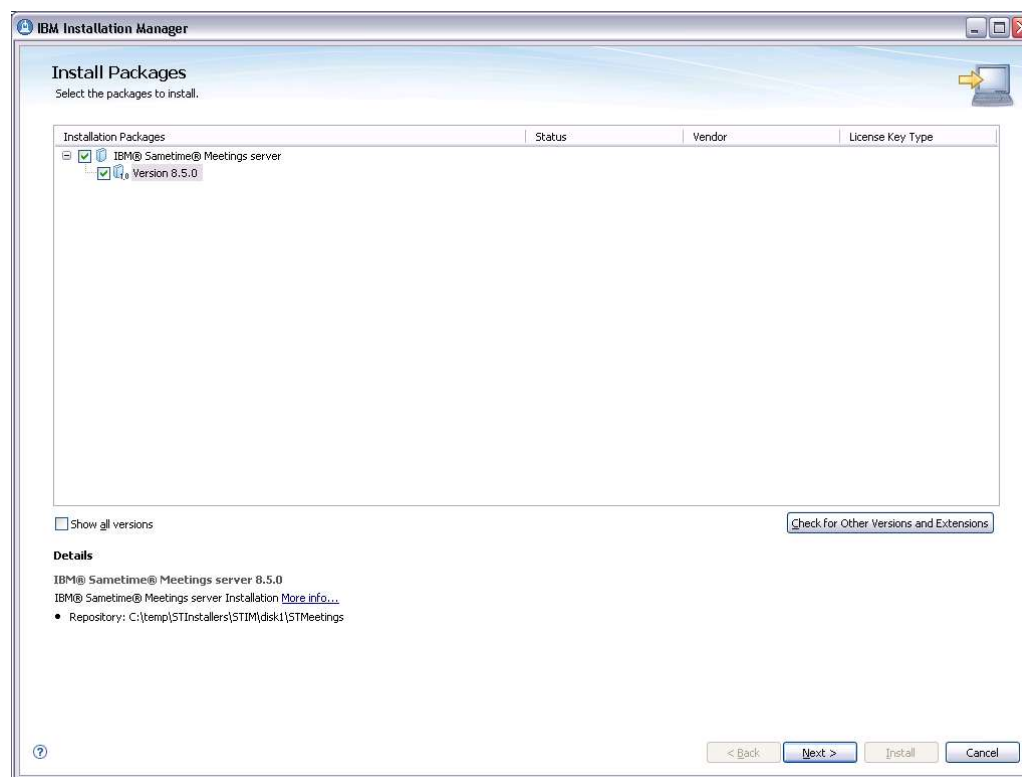

Web Meetings

Simple Web-only Setup

Pilots

Exploration

Etc.

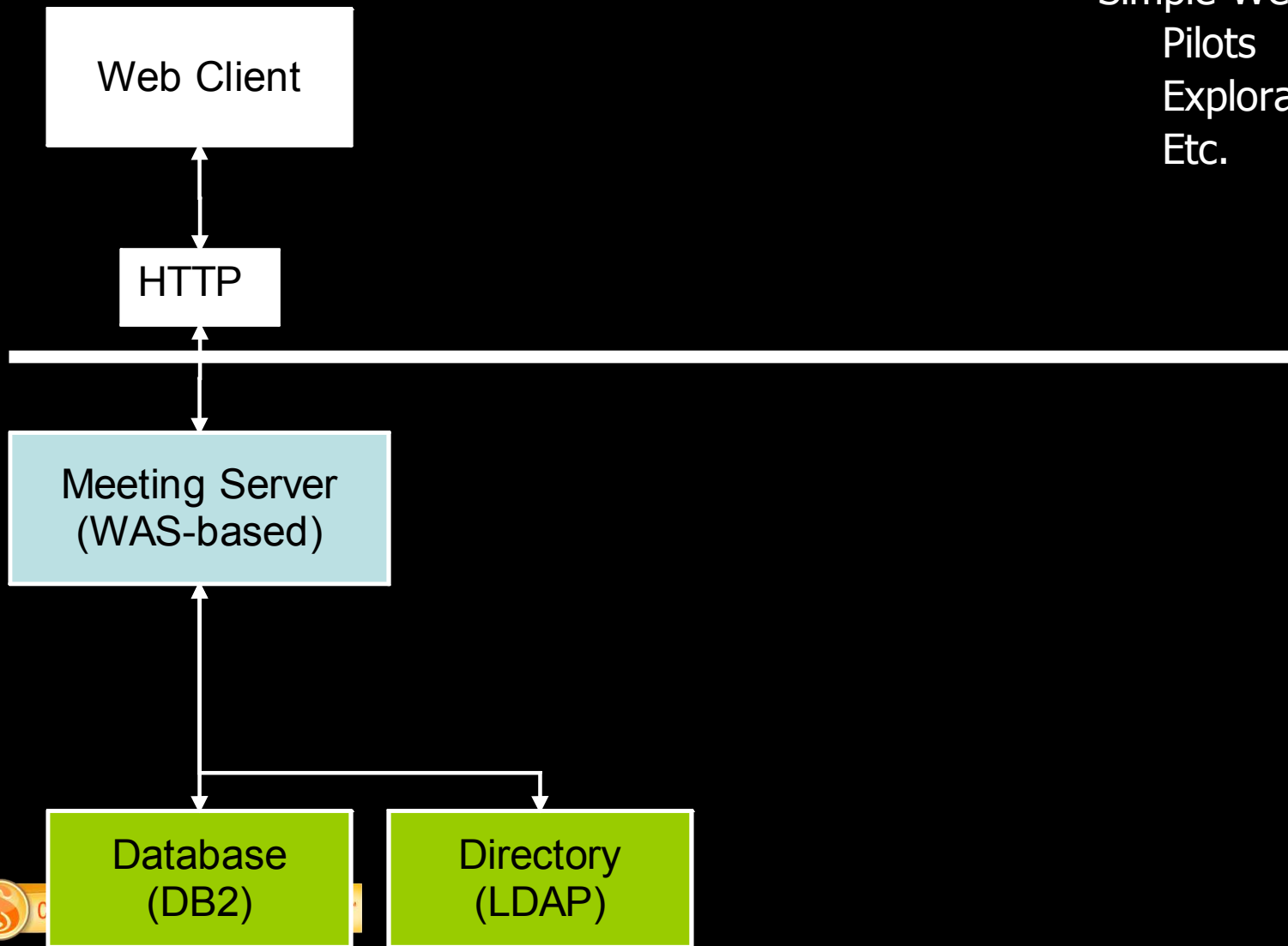

Web & Rich-Client Meetings

Sametime Rich-Client and Web
Leverage existing Sametime
deployment

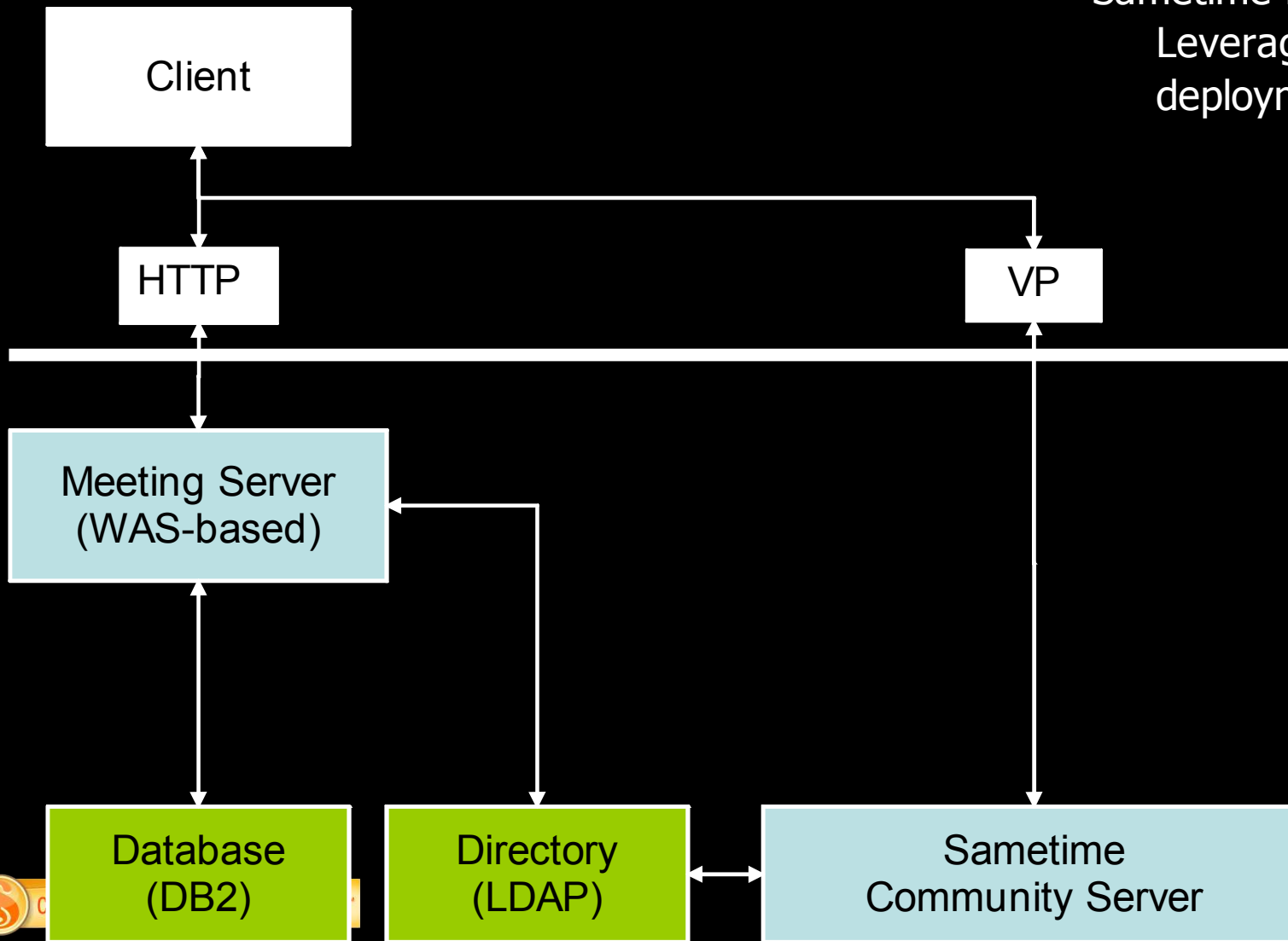

Web & Rich-Client, w/ SSC

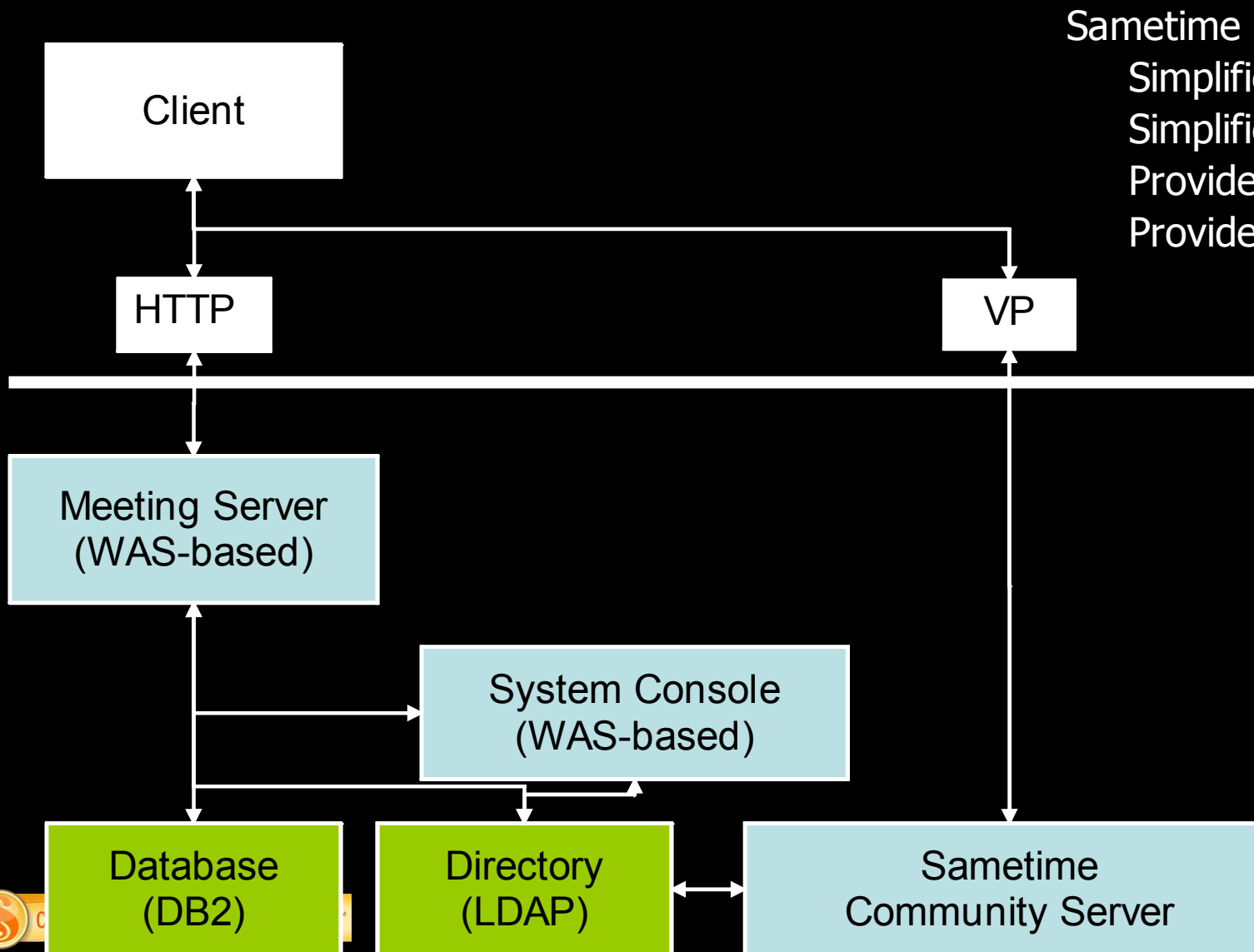

Sametime System Console
Simplifies install
Simplifies management
Provides GUI for Config
Provides GUI for policy

Web & Rich-Client, w/ SSC & Live Names

Sametime Proxy – Live Names
“Green Name” awareness
Chat from Live Names, etc.
Requires unique address !!

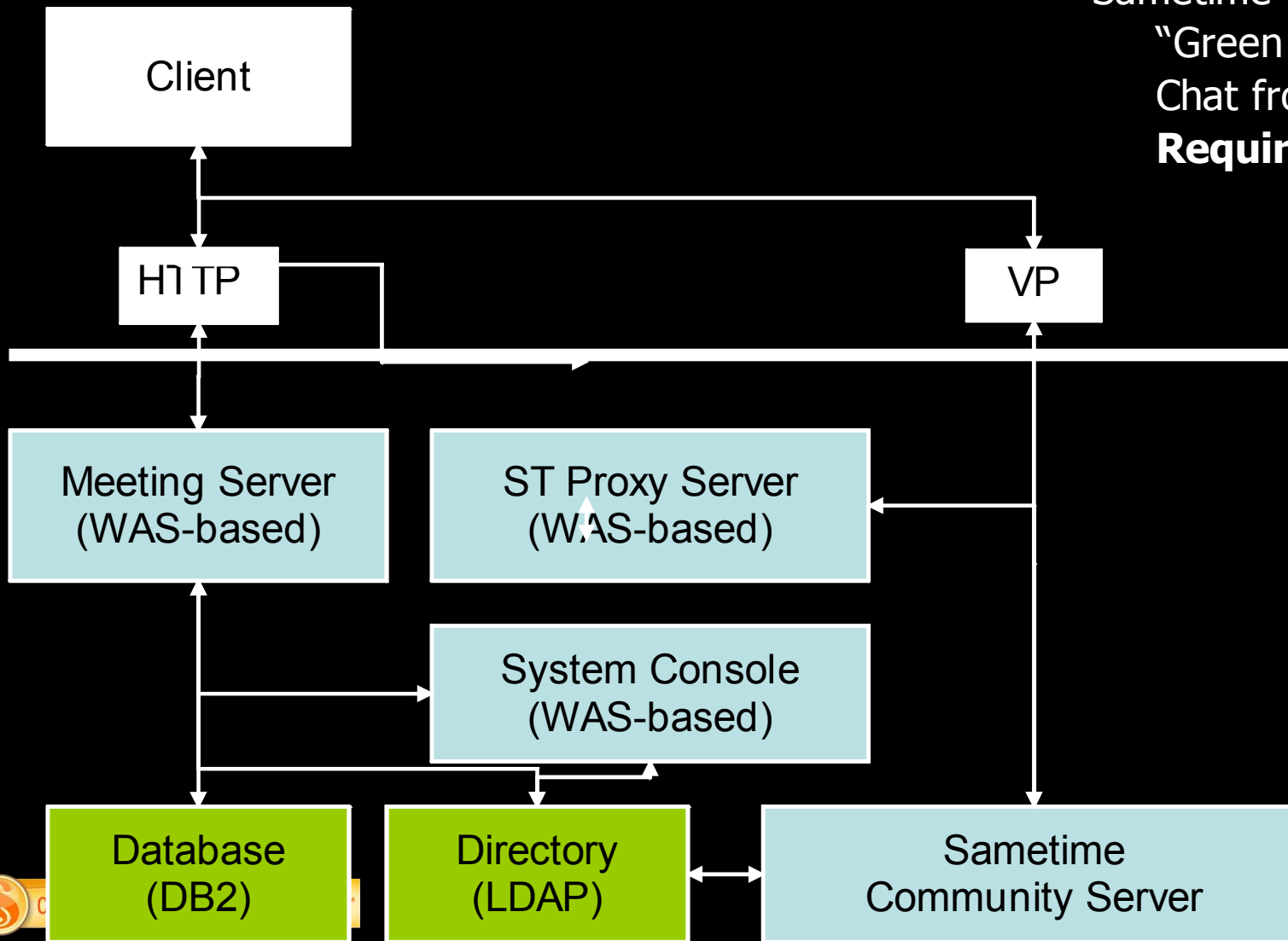

Web & Rich-Client, w/ SSC & Media

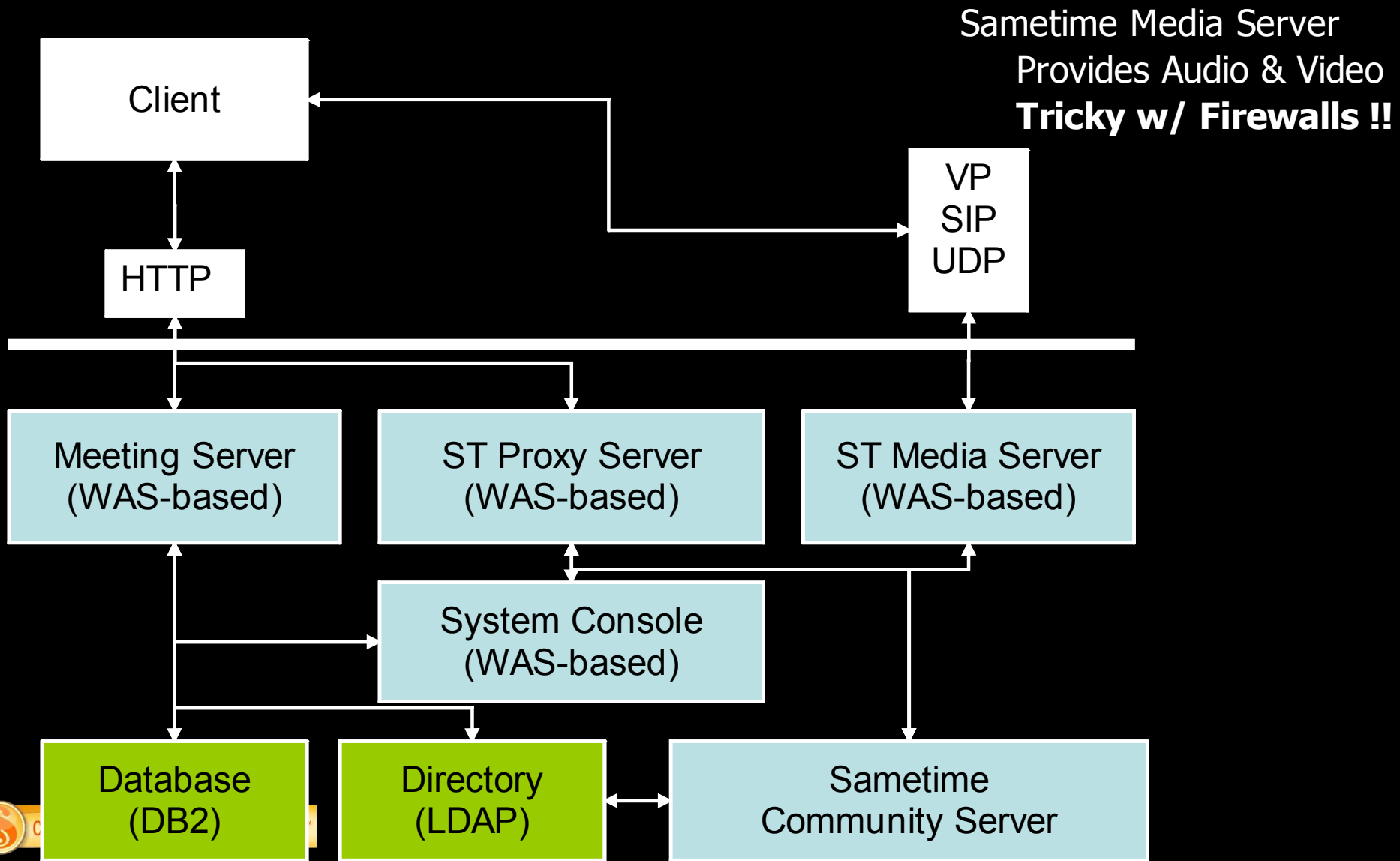

Clustered Meeting Server

Clustered Meeting Server

Load-balancing

Fail-over

Manual Setup

Recommend dedicated HW

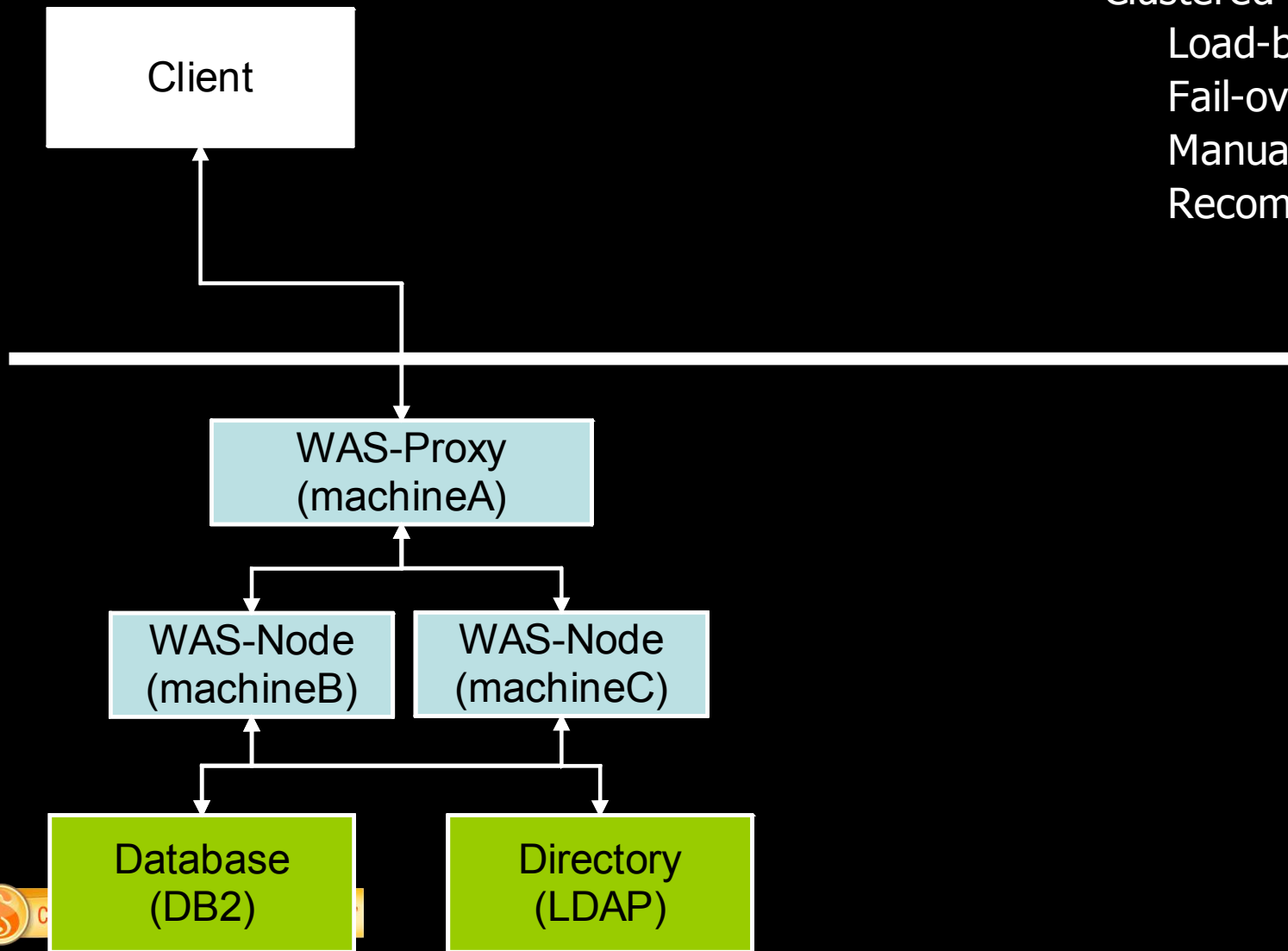



Jeszcze kilka obrazków...

Zapraszanie na konferencj? z klienta

Zaproś do spotkania

Start an Instant Meeting

Select a meeting room.

Meeting room server: stmeeting01.lotus.com

Meeting room: Sametime 8.5 demo New Meeting Room

Use this room by default for instant meetings

Invitees
To add people to the list, enter all or part of a name in the field below.

Name:

Invitees (2)	E-mail
Akiba Saeedi	akiba_saeedi@us.ibm.com
Robert Ingram	ringram@us.ibm.com

Remove Selected

...do istniejącego pokoju lub nowego...

Nowa miniaplikacja do zarządzania pokojami

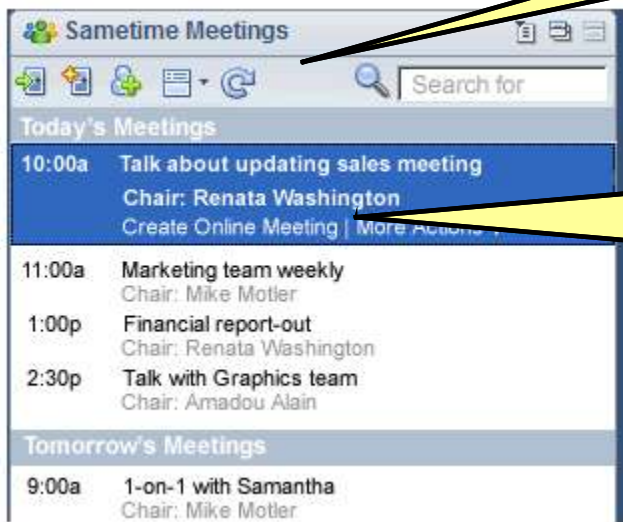
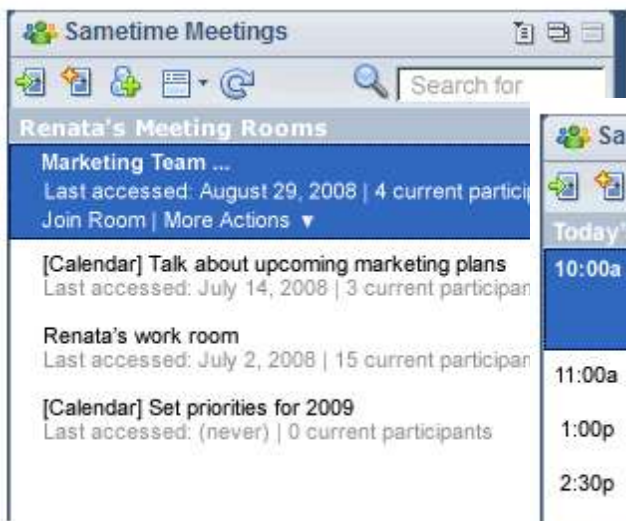

Tworzenie, dołączanie, zapraszanie

Łatwe zapraszanie ad-hoc dla spotkania z kalendarza

Tworzenie spotkania z kalendarza Notes

Save and Send Invitations Save as Draft Display Delivery Options... Check Calendar...

Return receipt Sign Encrypt

Calendar Entry

Type: Meeting

Mark Private
 Notify Me
 Mark Available

Istniejące pokoje

Subject: []

When: Starts: Tue 04/21/2009 11:30 AM
 Ends: Tue 04/21/2009 12:30 PM
 Repeat: This entry does not repeat

Who: Do not receive responses from inv...
 Required: []
 Optional: []
 FYI: []

Informacje o pokoju

Location: []

Include conference call information
 Local: 1-719-387-8316
 Toll Free: 1-866-907-1016
 Participant Passcode: 849856

Rooms: []
 Resources: []
 Online Meeting: There is no online meeting

Category: []

Reserve Online Meeting

Online Meetings ?

- My demo room
- Team Room

New ... Edit ... Delete

Preview

Meeting room name: Team Room

Service: Sametime Meetings

Meeting URL: http://stmeeting01.lotus.com/stmeetings/room/amy_travis@us.ibm.com/team-room

Password: No password required

Call-in information: 1-800-222-1199
 passcode: 592918

Include call-in information in the Location ?

OK Cancel

Tworzenie spotkania z kalendarza Outlook

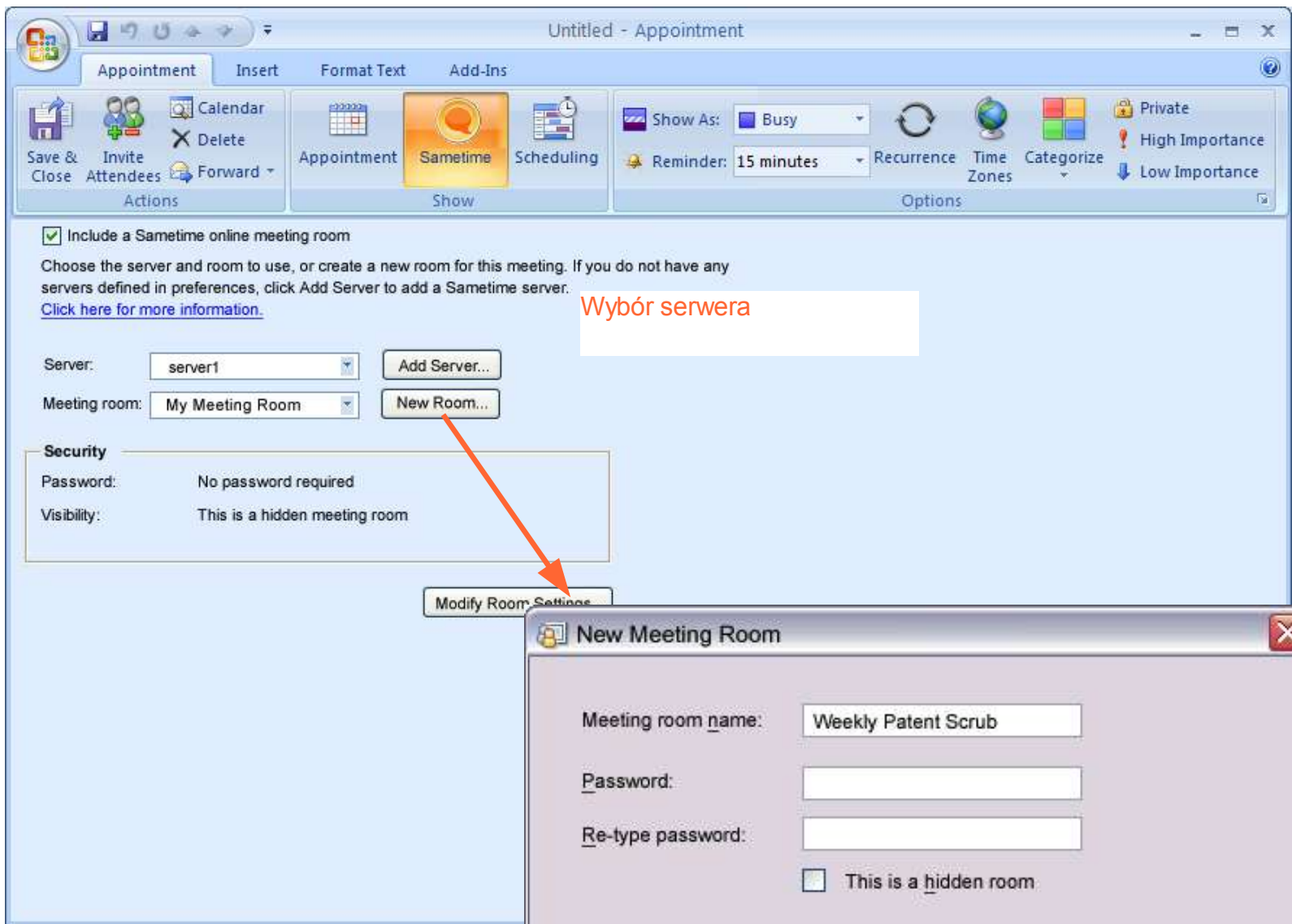

Participants - 6

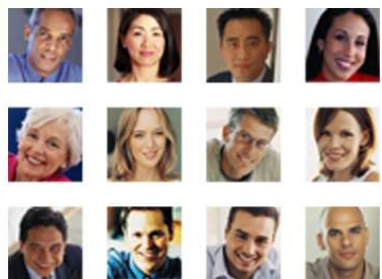

Drag and drop

Library

Organizational_Chart.odp

Share Download

Weeklymeetingnotes.odp

Legaldiscloser.odp

http://www.renovations.com

Image_2089.jpg

Materiały przechowywane w bibliotece

Discussion and Minutes

Gail Chao 10:02 a

Hey, welcome back Sam! Hope you had a great vacation!

Sam Curman 10:04 a

Hi Gail, thank you!

Rich text editor toolbar with icons for bold, italic, underline, link, and smiley.

Stop sharing You are sharing 3 of 6 Tools

Thumbnail navigation bar with 7 numbered slides.

Narzędzia prezentera - miniaturki, wskaźnik, rozmiar

Internal PR Plan

Samantha Daryn, Team Lead
Communications Task Force

Nagrywanie jako MOV

Raise Hand

Record



Participants - 6

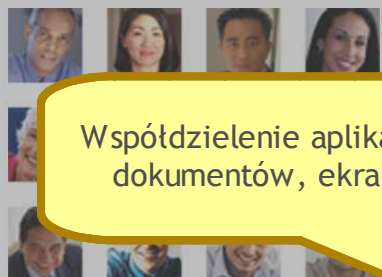

Współdzielenie aplikacji, dokumentów, ekranu

Stop sharing You are sharing

3 of 6

Tools



Share Content

Document or URL A currently running application The entire screen

Choose a running application, or click Add Application to access other applications on your computer.

- IBM Lotus Sametime
- IBM Lotus Symphony
- Inbox - IBM Lotus Notes
- Notepad**

Add Application...

Sharing quality: Fastest speed Normal Highest quality

Hide meeting room alerts while I'm sharing

OK Cancel

Library

Organizational_Chart.odp

Share Download

Weeklymeetingnotes.odp

Legaldiscloser.odp

http://www.renovations.com

Image_2089.jpg

Discussion and Minutes

Gail Chao 10:02 a

Hey, welcome back Sam! Hope you had a great vacation!

Sam Curman 10:04 a

Hi Gail, thank you!

Rich text editor toolbar: bold, italic, underline, abc, smiley

Bottom toolbar: save, copy, close, etc.

Raise Hand Record

Info, Help, and other utility icons

Participants - 6

- Gail Chao - Chairperson
- Sam Curman
- Samantha Daryn
- Philippe Babineaux
- Amadou Alain
- Betty Zechman

Library

- Organizational_Chart.odp
 - Share
 - Download
- Weeklymeetingnotes.odp
- Legaldiscloser.odp
- http://www.renovations.com
- Image_2089.jpg

Discussion and Minutes

- Gail Chao 10:02 a
 - Hey, welcome back Sam! Hope you had a great vacation!
- Sam Curman 10:04 a
 - Hi Gail, thank you!

b i u abc 😊

Stop sharing You are sharing

◀ 3 of 6 ▶ [Grid] [Zoom] [Share] [Tools]



Internal PR Plan

Samantha Daryn, Team Lead
Communications Task Force



Raise Hand



Web meetings:

<http://st85meetings.lotus.com/stmeetings/>

Web chat:

<https://st85meetings.lotus.com:9444/stwebclient/index.jsp>

Info center:

<http://publib.boulder.ibm.com/infocenter/sametime/v8r5/index.jsp>