

IBM Embedded ViaVoice

Highlights

- Provides fully integrated automatic speech recognition and text-to-speech capabilities for small mobile devices, including automotive telematics systems, personal navigation devices and hands-free phones
- Helps minimize the time and skills needed to develop advanced voice applications for devices and remote systems
- Includes free-form command support for natural and intuitive command phrases—eliminates the need to memorize commands
- Recognizes vocabulary lists exceeding 100 000 spoken words in real time and across a broad range of languages
- Provides an intuitive, easy-to-use developer toolkit powered by Eclipse technology
- Includes porting, integration, testing and consulting services provided by IBM, along with customized development workshops

Speech technology for small and mobile devices

Using speech technology as part of your day-to-day personal and business operations can make tasks quick and easy. These tasks can span a wide range from local voice control of devices in your car to voice access of information and services from a wide variety of mobile devices. To do this requires intuitive, outstanding speech-recognition, accuracy and natural-sounding speech. And you want to support multiple languages within the same consistent application interface and code base—all while keeping a small footprint.

That might sound like a lot to ask, but not with IBM Embedded ViaVoice® software. ViaVoice delivers superb speech technology for mobile devices, including:

- Automobile navigation systems
- Car infotainment with climate control systems and media players
- Hands-free phones
- Personal navigation devices (PNDs)
- Other smart devices

IBM enhanced technology is designed to meet your evolving needs. With Embedded ViaVoice automatic speech recognition (ASR) and text-to-speech (TTS) technology behind today's small mobile devices and automotive telematics systems, developers can easily provide users with voice command and control and voice access to information and services—whether users are at home, work or on the move.

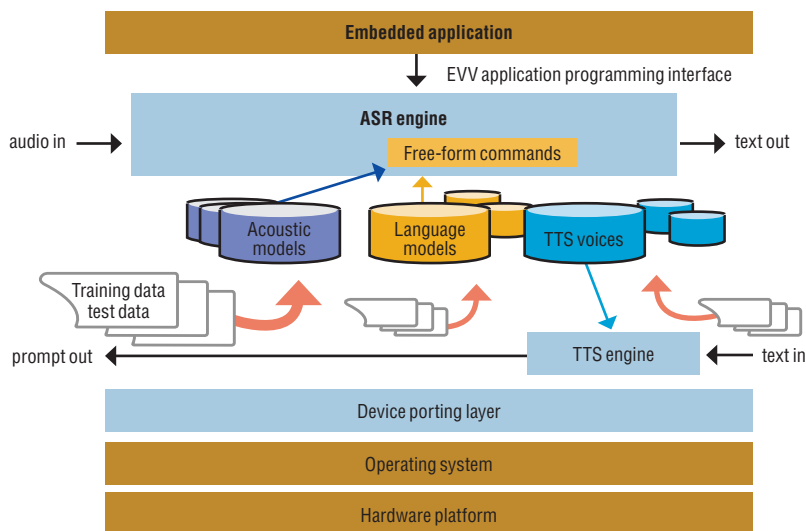

Embedded ViaVoice: Component view

Intuitive, natural communication

IBM free-form command support is included with Embedded ViaVoice. Free-form commands couple statistical language modeling and semantic interpretation, enabling application developers to create user interfaces that do not require the user to memorize specific commands. This means that users can speak naturally while using intuitive or idiomatic phrases. Embedded ViaVoice also includes formant as well as concatenated TTS. Concatenated TTS provides high-quality, natural-sounding voices and support for the Speech Synthesis Markup Language (SSML). Formant TTS provides very intelligible voices for devices with very minimal processor capability and memory.

Single, fully integrated architecture

The modular Embedded ViaVoice architecture provides fully integrated automatic speech recognition, speech synthesis (through TTS) and other technology engines. The architecture supports full-featured application requirements — on a variety of platforms — with minimal processor usage and memory requirements.

High-recognition accuracy

The Embedded ViaVoice recognition engine is based on small units of speech, called phonemes. The phoneme-based model uses finite-state grammars to support highly accurate and noise-robust continuous speech recognition. Not content to rest on our laurels, through comprehensive research and development, IBM has continuously improved the recognition accuracy of Embedded ViaVoice over the past several years.

Extensive vocabulary, broad language base

The maximum vocabulary supported by Embedded ViaVoice has grown by a factor of 25 over the past four years. Embedded ViaVoice now supports recognition of lists with a virtually limitless number of words, bounded only by the platform's processing and memory resources. Embedded ViaVoice is available in a broad set of languages and is supported by a worldwide network of IBM speech research and development laboratories.

Services and workshops

Integration services include porting to a new operating system, recompiling for a different processor architecture, or modifying the audio layer to use a new driver or codec. Alternatively, with a device adaptation kit, IBM supplies the tools that can enable you to perform and test the audio adaptations yourself.

IBM can provide on-site classes on the Embedded ViaVoice Software Developer Kit (SDK) to application developers. Also available are customized development workshops to provide skills transfer and instruction on application development, evaluation methodology and tools. That means you can design and tune your own system to suit your organization's business needs.

IBM Embedded ViaVoice software can enable you to gain a competitive advantage in today's fast-moving marketplace — and offers a clear path to growth through a single, fully integrated architecture.

For more information

To learn more about IBM Embedded ViaVoice, contact your IBM representative or IBM Business Partner, or visit:

ibm.com/speech



© Copyright IBM Corporation 2007

IBM Corporation
8051 Congress Avenue
Boca Raton, Florida 33487
U.S.A.

Produced in the United States of America
05-07
All Rights Reserved

IBM, the IBM Logo and ViaVoice are trademarks of International Business Machines Corporation in the United States, other countries or both.

References in this publication to IBM products or services do not imply that IBM intends to make them available in all countries in which IBM operates.

All statements regarding IBM future direction or intent are subject to change or withdrawal without notice and represent goals and objectives only.