

# IBM System z Technology Summit



## Charles Lewis - DB2 10 for z/OS Overview and Migration Strategy

January 27, 2011



# DB2 for z/OS The most robust and cost effective data server

## DB2

## DB2 9

## DB2 10



- Deep synergy with System z
- HW Compression
- Consolidation

- Up to 20% utility CPU savings
- Compress indexes, save 50% disk
- Native SQL procedures
- More CPU on specialty engines

- Save up to 5-10% CPU batch & transactions out-of-the-box (rebind)
- On-the-fly data Compression
- Temporal data support
- Skip-level migration



- Unmatched availability
- Unparalleled security
- Industry leading reliability

- Flexible context and role security
- Expanded online schema changes
- Volume level backup & recovery

- Ten times more concurrent users
- More online schema changes
- More granular access control



- Near-linear scalability
- Optimized for SOA
- Flexible development
- Warehousing capabilities

- Seamless integration of XML and relational
- Improved SQL
- Partition by growth
- OLAP expressions

- Enhanced query parallelism
- More SQL compatibility
- Improved pureXML and SQL PL

**V8 out of service April 2012**

# DB2 Deep Synergy With System z

## Key integration points include:

- Data sharing (availability and scale out)
- zIIP and other specialty engines
- Unicode conversion
- Encrypted communication & data
- Hardware data compression & encryption
- Cross-memory, memory protection keys
- Sorting
- Multi-core, large N-way
- 64-bit addressing and large memory
- z/OS Workload Manager
- z/OS Security Server (RACF)
- z/OS RRS integrated commit coordinator
- System z10 1 MB page size, decimal float
- Solid state disks
- zEnterprise z196, zBX, z10, ...



# System zEnterprise Benefits for DB2

*Taking System z synergy to the next level*

- Faster CPUs, more CPUs, more memory → better DB2 performance, scalability
- Compression hardware expected to increase DB2 data compression performance
- Cache optimization, 192M L4 Cache expected to benefit DB2 work
- Hybrid architecture query performance acceleration with IBM Smart Analytics Optimizer
- Excellent synergy with DB2 10 → significant CPU reduction and scalability increase
  - CPU reductions, increased zIIP usage
  - Remove key single system scaling inhibitors: virtual storage, latching, catalog, utilities, ...
  - Translation Lookaside Buffer changes expected to improve performance for 1MB page sizes
  - Buffer pool management



## Top 10 in DB2 10 for z/OS

1. CPU reductions for transactions, queries, & batch
  2. Ten times more users by avoiding memory constraints
  3. More concurrency for catalog, utilities, and SQL
  4. More online changes for data definition, utilities and subsystems
  5. Improved security with more granularity
  6. Temporal or versioned data
  7. SQL enhancements improve portability
  8. pureXML performance and usability enhancements
  9. Hash, index include columns, skip migration, ...
- Pick your favorite!**
10. Productivity improved for database & systems administrators, and application programmers



# DB2 10 for z/OS: Out-of-the-Box Savings

## CPU reductions for transactions, queries, and batch

- CPU reductions of 5-10% for traditional workloads
- CPU reductions of up to 20% for new workloads
- Up to additional 10% CPU savings using new functions
- For static SQL, REBIND typically required

## Scales with less complexity and cost

- 5-10x more concurrent users – up to 20,000 per subsystem
- Significant scale-up capabilities in addition to existing scale-out support
- Consolidate to fewer LPARs and subsystems

## Improved operational efficiencies and lower administration cost

- Automatic diagnostics, tuning, and compression

## Even better performance

- Elapsed time improvement for small LOBS and Complex Queries



# DB2 10 for z/OS - Feedback from Beta Customers

We are really thrilled about "Temporal Data" feature – this feature has the potential to significantly reduce overheads. We have estimated that 80% of our existing temporal applications could have used “the DB2 10 temporal features” instead of application code - this feature will drastically save developer time, testing time – and even more importantly make applications easier to understand so improve business efficiency and effectiveness

Frank Petersen -System Programmer

**BANKDATA**

bankdata

*“We use very large buffer pools – some of them up to 3.2GB in size. We rely on efficient access to buffered data and any saving in the cost of accessing that data will be very beneficial.”*

Philipp Nowak, BMW DB2 Product Manager

*We have measured a 38% reduction in CPU and a 7% reduction in suspend time for some heavy insert workloads in a data sharing environment. That’s a significant saving which provides immediate business benefit.”*

Philipp Nowak, BMW DB2 Product Manager

# What Customers are Saying

*Continuous availability, reduced performance cost and future growth with constraints are of paramount importance to our business. We are really excited about the potential of DB2 10 for z/OS to help us achieve our goals in each of these areas. Our high expectation is the reason why Danske Bank will invest a lot of effort in the Beta program."*

Jan Michael Christensen,  
Vice President, Danske Bank

Danske Bank



*"DB2 10 enhances our ability to support our rapidly growing workloads while delivering some very valuable new function with immediate business benefits."*

Paulo Sahadi, Senior Production Manager, Information Management Division, Banco do Brasil

***As a multi-national corporation, we must adhere to strict local audit requirements. The security and administration capabilities in DB2 10 are a key driver for us to move to this version.***



*"In addition to the cost savings, DB2 10 for z/OS offers a far superior data server environment than Oracle database"*

***Manuel Gomez Burrierl  
CECA (Spanish Bank Federation)***



## Sample of Beta Customers' Performance Feedback

Workload	Results
Customer1: Distributed Concurrent Insert	50% DB2 elapsed time reduction 15% chargeable CPU reduction after enabling high perf DBAT
Customer2: CICS online transactions	Approx. 7% CPU reduction in DB2 10 CM after REBIND, Another 4% reduction with 1MB page usage
Customer3: CICS online transactions	Approx 5% CPU reduction
Customer4: Data sharing heavy concurrent insert	38% CPU reduction
Customer5: Queries	Average CPU reduction 28% from V8 to DB2 10 NFM
Customer6: Batch	Overall 28% CPU reduction after rebind packages
Customer7: DDF OLTP	40% CPU reduction for JDBC stored procedures workload, 15% CPU reduction for securities trading app

## Beta Customers' Feedback on Selected New Functions

Workload	Results
Multi row insert (data sharing)	33% CPU reduction from DB2 9, 4x improvement from V8 due to LRSN spin reduction
Parallel Index Update	30-40% Elapsed time improvement with class 2 CPU time reduction
Inline LOB	SELECT LOB shows 80% CPU reduction
Include Index	17% CPU reduction in insert after using INCLUDE INDEX
Hash Access	<p>20-30% CPU reduction in random access</p> <p>16% CPU reduction comparing Hash Access and Index-data access.</p> <p>5% CPU reduction comparing Hash against Index only access</p> <p>Further improvements delivered late in the beta program.</p>

## DB2 10 Catalog and Directory Improvements

- **Remove links and enable row level locking on key catalog tables**
  - Improved concurrency for BIND, PREPARE, and DDL
  - DSN1CHKR no longer needed in DB2 10 NFM
- **Move long strings such as SQL statements and package binaries to LOBs**
  - Removes max size constraint for SPT01 and others
  - Easier to query SQL statements from catalog
- **Online REORG for all catalog and directory table spaces**
- **Allow SELECT from SYSLGRNX**
- **Easier management: DB2 managed and SMS controlled**

## Availability – More Online Schema Changes

- **Online schema changes for table spaces, tables and indexes – PENDING with ALTER and Online REORG instead of DROP/CREATE or REBUILD INDEX**

### **Alterations occur with REORG, unless noted otherwise**

- Page size for table spaces and indexes
- DSSIZE for table spaces
- SEGSIZE
- Convert single table segmented into UTS PBG
- Convert single table simple into UTS PBG
- Convert classic partitioned table space into UTS PBR
- Convert UTS PBR to UTS PBG
- Convert PBG to hash (immediate, but RBDP index)
- MEMBER CLUSTER
- Ability to drop pending changes

## Virtual storage improvements

- **DBM1 below 2GB**
  - 75-90% less usage in DB2 10 compared to DB2 9
  - Some of working storage (stack, xproc storage) stays below 2GB
- **Larger number of threads**
  - Possible data sharing member consolidation
- **Improve CPU with storage**
  - More release deallocate
  - Larger MAXKEEPD values for KEEP DYNAMIC=YES

### DB2 10

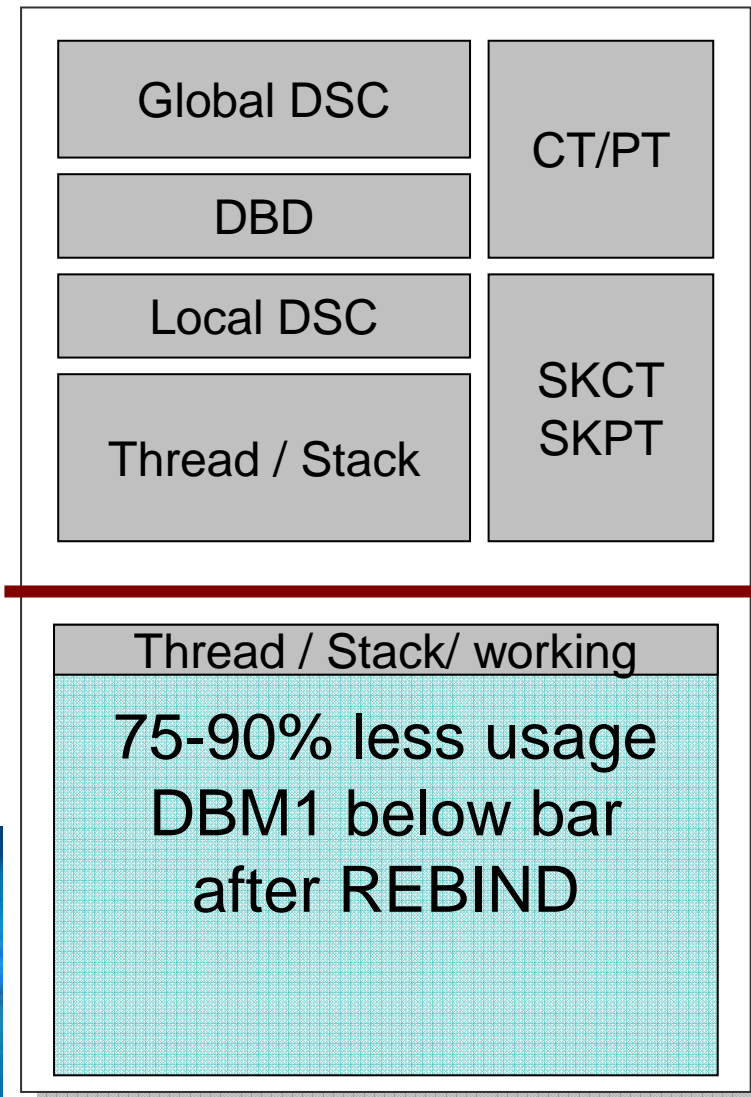

# Running Many Active Threads

## Today

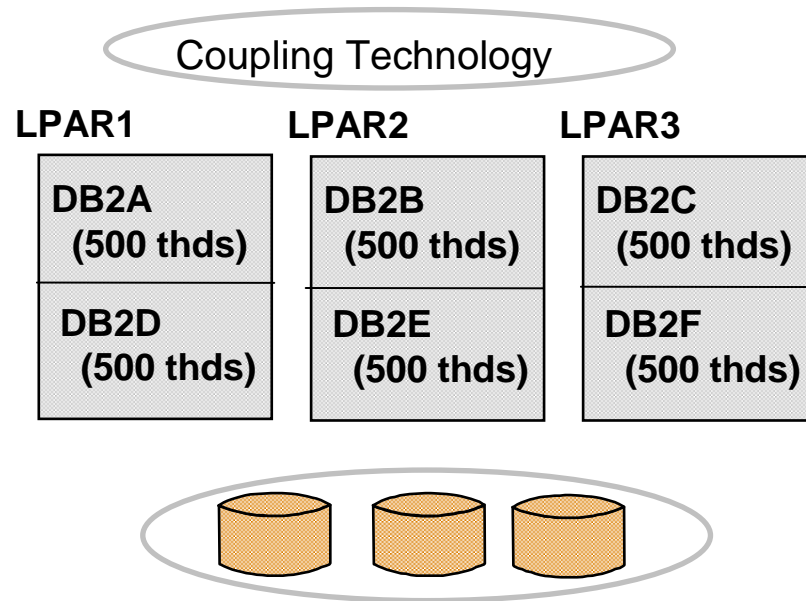

- Data sharing and sysplex allows for efficient scale-out of DB2 images
- Sometimes multiple DB2s per LPAR

## DB2 10

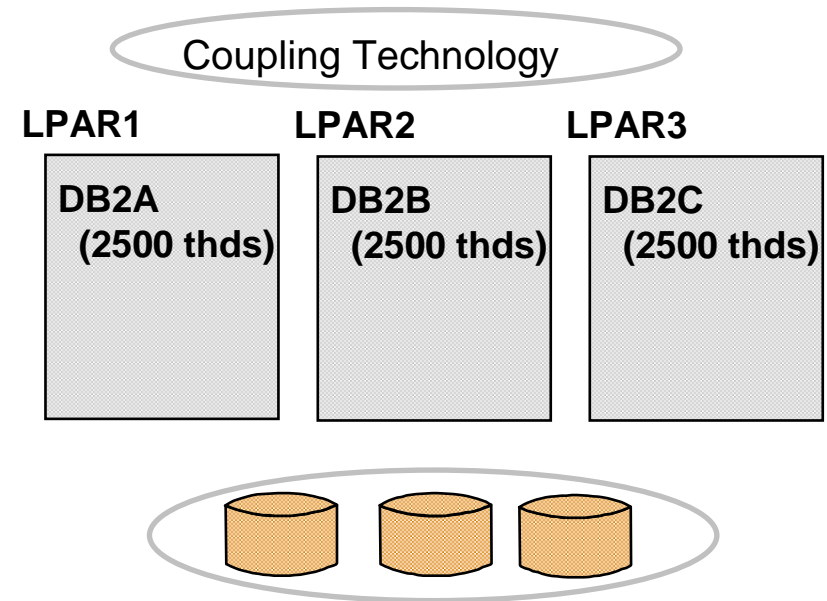

- More threads per DB2 image
- More efficient use of large n-ways
- Easier growth, lower costs, easier management
- Data sharing and Parallel Sysplex still required for very high availability and scale
- Rule of thumb: save ½% CPU for each member reduced, more on memory

# Business Security & Compliance

- Protect sensitive data from privileged users & improve productivity
  - SECADM & DBADM without data access
  - Usability: DBADM for all DB
  - Revoke without cascade
- Separate authorities to perform security related tasks, e.g. security administrator, EXPLAIN, performance monitoring and management
- Audit privileged users
- Row and column access control
  - Allow masking of value
  - Restrict user access to individual cells



## DB2 10: Productivity – Doing More with Less!

- Easier performance & scaling, simpler memory management
- Reduce contention, more online processing
- Access path stability
- Reduced need for REORG
- Auto statistics collection
- Monitoring enhanced

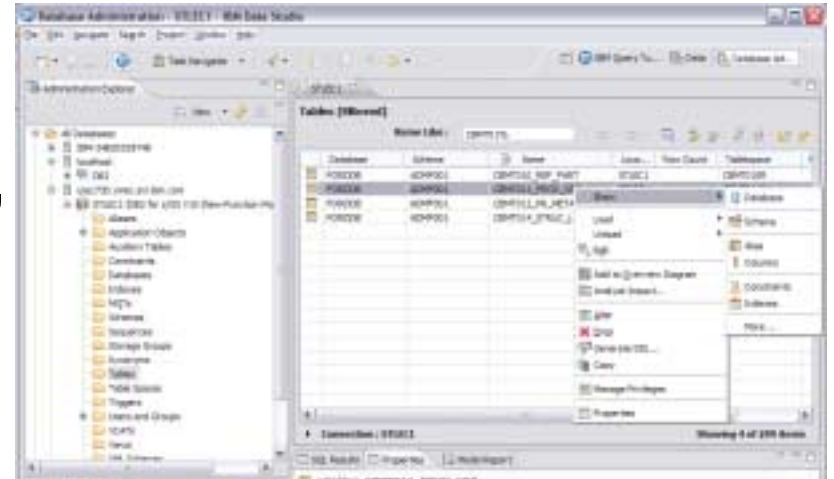



## DB2 10 Application Enablement and Portability

- **Data versioning by date**
- **pureXML enhancements**
- **Large object improvements**
  - Allow non-NULL default values for inline LOBs
  - Loading and unloading tables with LOBs
    - LOBs in input/output files with other non-LOB data
- **Improved portability and SQL consistency**
  - Currently committed locking semantics
  - Implicit casting or loose typing
  - Timestamp with time zone
  - Variable timestamp precision – seconds to picoseconds
  - Moving Sum, Moving Average

## DB2 10 More New Application Features

- **SQL stored procedure enhancements**
  - SQL PL in Scalar UDFs & XML support
- **64-bit ODBC – also DB2 9 PK83072**
- **EXTENDED INDICATOR VARIABLES to indicate value not supplied or default**
- **DRDA support of Unicode for system code points**
- **CURRENT EXPLAIN MODE special register**
- **Allow caching of dynamic SQL statements with literals**
- **Data-dependent paging**
  - When only a specific part of the result set is needed
  - Efficient access to desired portions of result set, based upon current position

# Temporal data or versioned data

- **Table-level specification to control data management based upon time**
- **Two notions of time:**
  - System time: notes the occurrence of a data base change
    - “row xyz was deleted at 10:05 pm”
    - Query at current or any prior period of time
    - Useful for auditing, compliance
  - Business time: notes the occurrence of a business event
    - “customer xyz’s service contract was modified on March 23”
    - Query at current or any prior/future period of time
    - Useful for tracking of business events over time, application logic greatly simplified
- **New syntax in FROM clause to specify a time criteria for selecting historical data**



# Many improvements for SAP & web applications

## Autonomics

- Compress on the fly on INSERT
- Auto-statistics
- Hints enhancements
- Access path lock-in and fallback for dynamic SQL
- Automatic checkpoint interval
- Automated installation, configuration & activation of DB2 supplied stored procedures & UDFs
- Data set FlashCopy in COPY & inline copy
- Inline image copies for COPY YES indexes
- UNLOAD from FlashCopy backup
- REORG enhancements
- Reduce need for reorganizations for indices

## Performance

- CPU reductions
- Hash access path

- Numerous optimizer enhancements, paging through result sets
- Parallel index update at insert
- Faster single row retrievals
- Inline LOBs
- LOB streaming between DDF and rest of DB2
- Faster fetch and insert, lower virtual storage consumption
- DEFINE NO for LOBs and XML
- MEMBER CLUSTER for UTS
- Query parallelism enhancements: lifting restrictions
- Dynamic Index ANDing Enhancements
- Option to avoid index entry creation for NULL value
- Index include columns
- Buffer pool enhancements

## Scalability

- Many more threads
- Reducing latch contention
- Workfile spanned records, PBG support, and in-memory enhancements

## Availability

- More online schema changes for table spaces, tables and indexes via online REORG
- Online REORG for LOBs
- Online add log  
Automatically delete CF structures before/during first DB2 restart

## Portability

- Allow non-NULL default values for inline LOBs
- Loading and unloading tables with LOBs in stream
- Currently committed locking semantics
- Default SAP settings for DB2

## Security

- More granular DBA privileges

## XML

## pureXML improved performance & usability

- XML schema validation in the engine for improved usability and performance
- Binary XML exchange format improves performance
- XML multi-versioning for more robust XML queries
- Allow easy update of XML document nodes
- Stored procedure, UDF, Trigger enhanced support
- XML index matching with date/timestamp
- CHECK DATA utility checks XML

# DB2 Tools for z/OS: Day 1 Savings with IBM Tools

- Exploit DB2 10 performance savings out of the box
- Optimize Performance Across Multi-Platform Applications
- Lower CPU costs while reducing batch windows
- Higher data availability through simplified recovery operations



**All New with DB2 10!**

**DB2 Utilities Suite V10** drives down costs with autonomies, page sampling and further offloads processing to zIIPs and FlashCopy. Developed in conjunction with DB2 10 to provide maximum data integrity and exploit all new functions out of the box.

**Tivoli OMEGAMON XE for DB2 Performance Expert V5.1** extends its insight into distributed workloads and offers a robust infrastructure to support DB2 10 subsystem consolidation, with lower monitoring overhead.

The recommended performance monitor of DB2 10!

**DB2 Sort V1.1** lowers the cost of DB2 Utility sort processing by exploiting advanced features of System z and z/OS while optimizing overall system efficiency. Significantly reduces batch windows.

**DB2 Administration Tool V10.1** extends the value of DB2 10 with new capabilities that allow DBAs to quickly exploit DB2 10 features like schema evolution. Reduces the overhead of many routine tasks.

**Jump into DB2 10! The water's fine.**



**DB2 V8**

**DB2 9**

**DB2 10**

**Key Questions are WHEN? and HOW?**

## Feedback: Top Items Driving DB2 10 Migration Decisions

- **CPU / Performance improvements**
- **Virtual storage enhancements**
  - Reduce number of members, save money
- **Stability & regression**
- **Security enhancements**
  - Built-in security, trace & audit features, new roles, end-to-end auditing
  - Cleaner/safer environment; Better audit/compliance
- **Temporal**
- **Skip-level migration DB2 V8 → DB2 10**

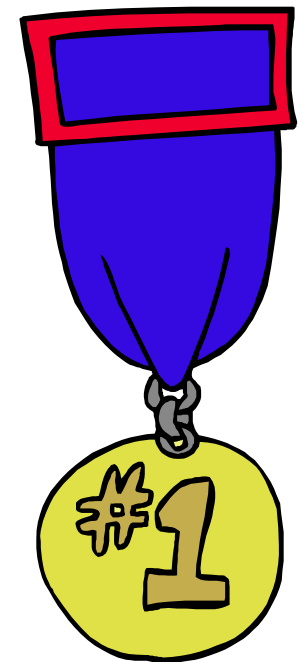

**Vast majority of beta customers plan production in 2011**



# Sample Improvements

- **Run time CPU reductions**            **5% - 10%**
- **1 MB page size**                    **0% - 4%**    **z10, z196**
- **Page fix buffers**                    **0% - 8%**    **since V8**
- **Release deallocate**                **0% - 15%** **short trans, batch**
- **Virtual storage constraints**        **0% - 5%**    **memory, latches**
- **Data sharing fewer members**      **1% for each 2 members**
- **Improved dynamic SQL cache**      **0% - 20%** **literals**
- **Insert**                                **0% - 40%** **high volume insert**
- **Predicate evaluation**                **0% - 60%** **complex predicates**
- **Access: hash, index include**        **0% - 5%**    **access improved**
- **Increased use of zIIP**                **0% - 3%**    **IO, RUNSTATS, par**
- **Utilities (from V8)**                    **3% - 20%**
- **Productivity: memory, temporal, security, admin, ...**    **priceless**

## Migration path options:



DB2 9 → DB2 10

DB2 V8 → DB2 9 → DB2 10

DB2 V8 → DB2 10

# DB2 10 for z/OS At a Glance

## Performance, Scalability

- CPU reductions out-of-the-box
- Hash access to data, index include columns
- Ten times more threads per DB2 image

## Availability Security Productivity

- More online schema changes
- Improved concurrency: catalog, data, & utilities
- Row and column access control, masking
- Administrator privileges with finer granularity
- Administration productivity enhancements

## Application Enablement

- Versioned data or temporal queries
- pureXML enhancements
- SQL improvements that simplify porting

## Dynamic Warehousing

- Moving sum, moving average
- Many query optimization improvements
- Query parallelism restrictions removed
- IBM Smart Analytics Optimizer

# DB2 for z/OS Business Value References

Information Management



## DB2 10 for z/OS Technical Overview

Information Management



Draft Document for Review January 6, 2011 1:28 pm

## Extremely pureXML in DB2 10 for z/OS

Information Management software



## DB2 9 for z/OS Technical Overview

Read about the new features and functions of DB2 Version 9.1 for z/OS

Understand prerequisites and migration process

## IBM System z Strengths and Value

DB2 10 for z/OS  
Proven, simplified and cost effective

- Technical presentation of System z hardware and z/OS
- Enterprise-wide rules for the System z platform
- Cost of competing considerations



Triton  
CONSULTING

**DB2 10 for z/OS**  
A Smarter Database for a Smarter Planet

# Questions?



Watch for upcoming white papers and conferences  
IOD IDUG Share