



# ISM for zEnterprise ensures service quality and integrity across hardware and software



ISM extends across all zEnterprise service management layers

*Integrated Service Management*

Service Lifecycle Management

Higher Quality  
Lower Risk



VISIBILITY



CONTROL



AUTOMATATION

Platform Management

Productivity Savings



**IBM zEnterprise Unified Resource Manager (zManager)**

Systems & Hardware

CapEx Savings



**Consolidation & virtualization on IBM zEnterprise**



**Workload optimization**

# zManager enables ISM by providing Platform and Hardware Management for zEnterprise resources

Integrated Service Management

## Service Management

- End-to-End Workload and Security Management that align IT Management with Business Goals
- Common Usage and Accounting for business management
- Dynamic Management of Application Workloads based on Policies

## Platform Management

- Workload based Resource Allocation and Provisioning
- Physical and Virtual Resource Management
- Goal Oriented Resource Management of zEnterprise

## Hardware Management

- Configuration management
- Operational controls
- Lifecycle management for the platform's virtual resources

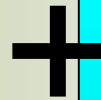

## PLUS zManager:

- Virtualization management – single view of virtualization across z platform
- Hypervisor management and creation of virtual networks
- Operational controls, service and support
- Workload awareness and platform performance management
- Energy Monitoring and Mgmt

# Architecture Vision: consolidate Integrated Service Management on System z

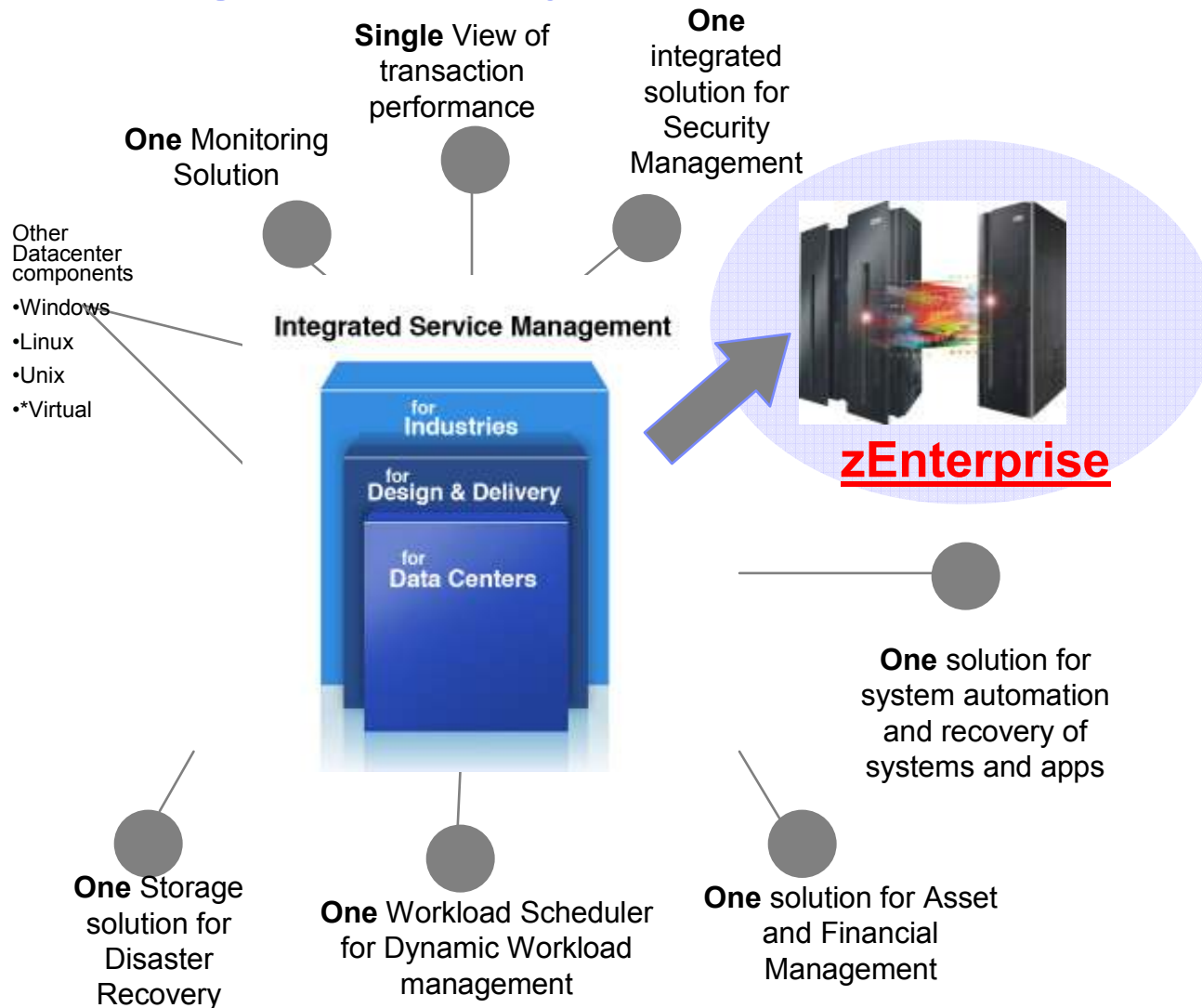

## IBM Advantage

- ✓ **Visibility. Control. Automation™** with a *SINGLE POINT OF CONTROL* on a common infrastructure
- ✓ *Consolidated view of the IT infrastructure*
- ✓ *Lower training and maintenance costs*
- ✓ *Integrated, consolidated reporting*
- ✓ *Asset optimization*

## Offerings available today for System z

### **Tivoli Application Management for zEnterprise**

- Ability to view, monitor and manage applications for physical and virtual machines
- Alerting capabilities for early detection of costly slow downs or outages

### **Tivoli Asset and Financial Management for zEnterprise**

- Visibility into software usage and compliance across heterogeneous resources
- Greater efficiency of resource usage
- Central view and management of requirements and costs

### **Tivoli Security for zEnterprise**

- Simplified administration and monitoring, reducing the time to perform everyday tasks
- Compliance with both internal security policies and external government laws and regulations
- Automation, for a faster and more consistent response to problems with and reduced costs

### **Tivoli Application Resilience for zEnterprise**

- Automated high availability and disaster recovery operations across multi-tier environments
- Central view and management of critical business processes

# Monitor and manage application performance and availability

\* New!

## Tivoli Application Management for zEnterprise

### End-to-end service management support

- Application monitoring and transaction tracking capability for heterogeneous zEnterprise environment

### Key capabilities

- Integrated end-to-end active and passive monitoring
- View and monitor workloads for composite applications, physical and virtual machines, groups and response times
- Alerting capabilities for early detection of costly performance problems and outages



### Products:

- Tivoli Business Service Manager
- OMEGAMON XE for CICS, DB2, Messaging
- OMEGAMON DE on z/OS
- ITCAM for Application Diagnostics, Transactions, Applications, SOA

## Provide centralized asset and cost visibility for shared business and IT resources

**\* New!**

### Tivoli Asset and Financial Management for zEnterprise

Ability to determine, track and cost shared resource usage for business end-to-end

#### Key capabilities

- Visibility into software usage and compliance across heterogeneous resources
- Provide audit ready data
- Alignment of IT costs with business objectives



#### Products:

- Tivoli Usage and Accounting Manager
- Tivoli Asset Management for IT
- Tivoli Asset Discovery for z/OS
- Tivoli Decision Support for z/OS

# Enterprise Security Hub across production systems and consolidated virtual system workloads

New and Enhanced!

## Tivoli Security for zEnterprise

### Expanding security across Linux on z

- Supports recent mainframe, RACF, and zSecure security enhancements

### Key capabilities

- Updated federation standards for on- and off-premise access including software as a service (SaaS) and cloud-based services
- Define business-level security needs while reducing complexity and cost of securing applications and services



### Products:

- Tivoli zSecure suite and Tivoli Security Management for z/OS
- Tivoli zSecure Manager for RACF z/VM
- Tivoli Federated Identity Manager for Linux on z
- Tivoli Access Manager Family



# Optimize availability and resiliency of multi-tier, composite application environments

**\* New!**

## Tivoli Application Resilience for zEnterprise

End-to-end applications and integrated operations management for multi-platforms

### Key capabilities

- Single end-to-end point of control for resource automation throughout zEnterprise
- Aggregate and centrally manage cross-enterprise, heterogeneous workloads to support business goals and service levels
- Automated High Availability and Disaster Recovery to meet business service level requirements



### Products:

- System Automation for z/OS, Multiplatforms, Application Manager
- System Automation for Integrated Operations Management
- Tivoli Workload Scheduler

# Integrated Service Management capabilities enhanced for zEnterprise

**Tivoli OMEGAMON XE for Mainframe Networks** provides the visibility into the OSA CHPID types and interface types specific to zEnterprise network

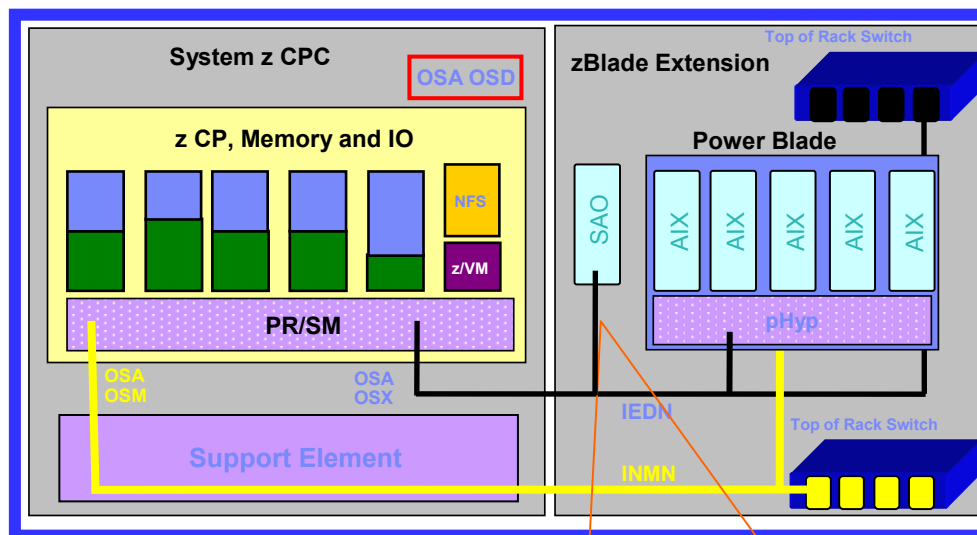

**Tivoli OMEGAMON XE for DB2** will provide visibility into the offload of DB2 on z/OS warehouse queries to the **Smart Analytics Optimizer**

## Questions?

The importance of Integrated Service Management for exploiting zEnterprise

Paul M Smith (paulmsm@us.ibm.com)  
Dean Butler (butlerde@us.ibm.com)