



# **zEnterprise – An Ideal Basis For Smarter Computing**

Understanding The Value  
Of The Mainframe Today

# Agenda

<b>50 minutes</b>	<b>Understanding The Value Of The Mainframe Today</b>
<b>50 minutes</b>	<b>Simplify And Compress Hardware Infrastructure With zEnterprise</b>
15 minutes	<i>Break</i>
<b>50 minutes</b>	<b>System z – The Best Place For Business Analytics</b>
<b>10 minutes</b>	<b>Academic Initiative</b>
60 minutes	<i>Lunch</i>
<b>50 minutes</b>	<b>Improving Service Delivery With Private Cloud Computing</b>
15 minutes	<i>Break</i>
<b>50 minutes</b>	<b>TCO Lessons From Customer Engagements</b>
<b>50 minutes</b>	<b>Developing Hybrid Applications For zEnterprise</b>
5 minutes	Close

# A Fundamental Shift In Costs Is Underway...

## Worldwide IT Spending on Servers, Power, Cooling and Management Administration

- New server spending
- Power and cooling costs
- Server management and admin costs

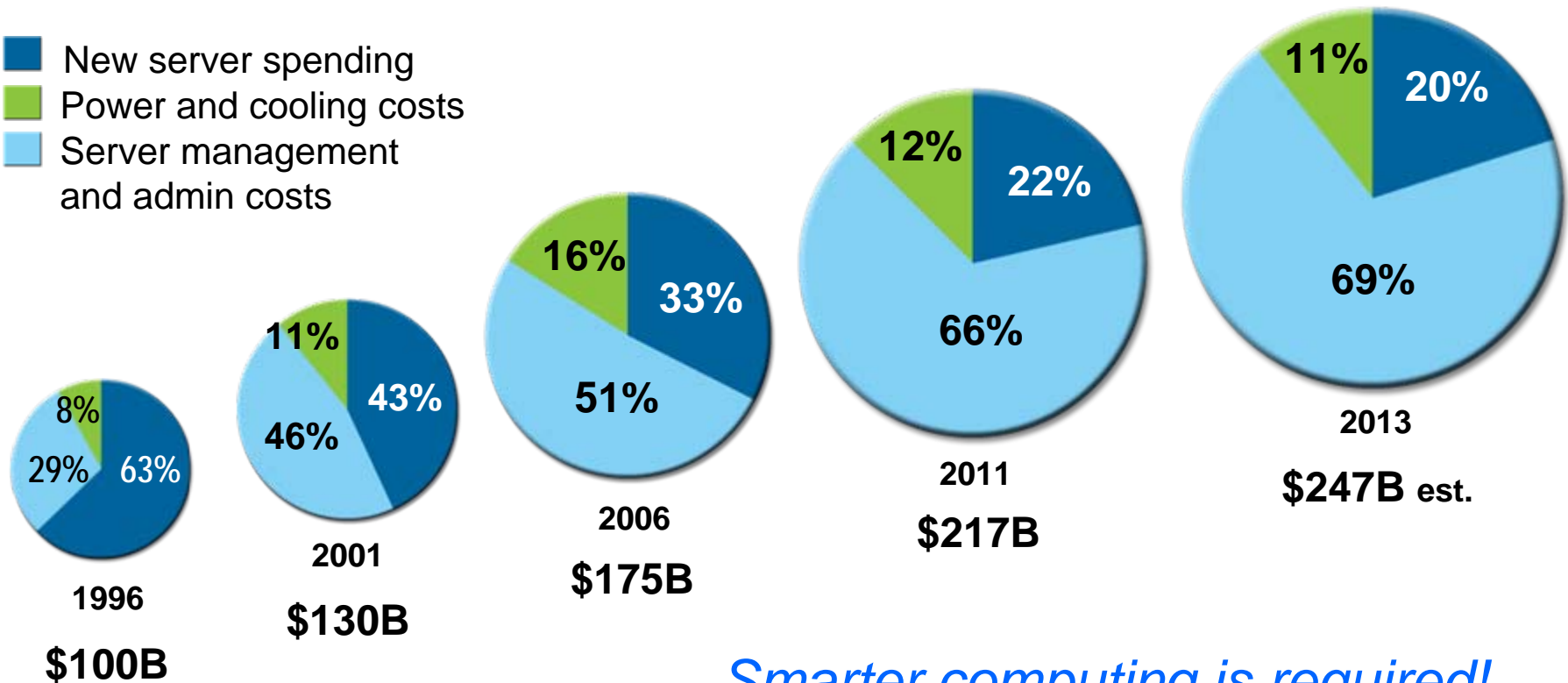

*Smarter computing is required!*

# Adopting Smarter Computing Strategies Reduces Costs And Improves Value

**Consolidate servers on virtualized platforms**

Reduce Hardware Infrastructure

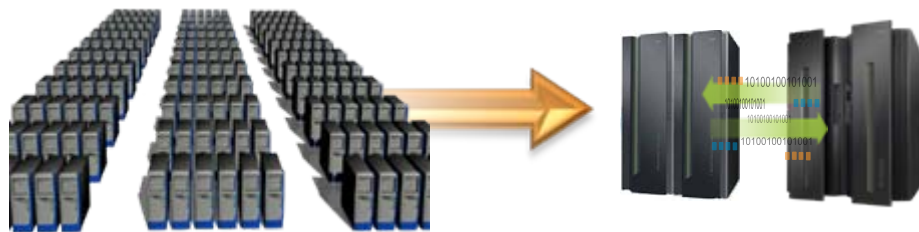

**Leverage systems optimized for specific workloads**

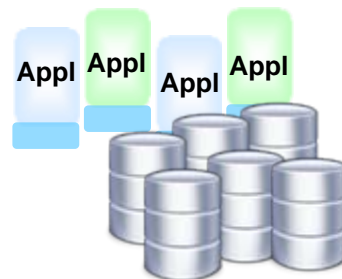

Processor intensity

Data intensity

**Reduce labor costs with a private cloud**

Integrated Service Management



Visibility



Control



Automation



Cloud Computing

# System z Plays A Major Role In A Smarter Computing Strategy

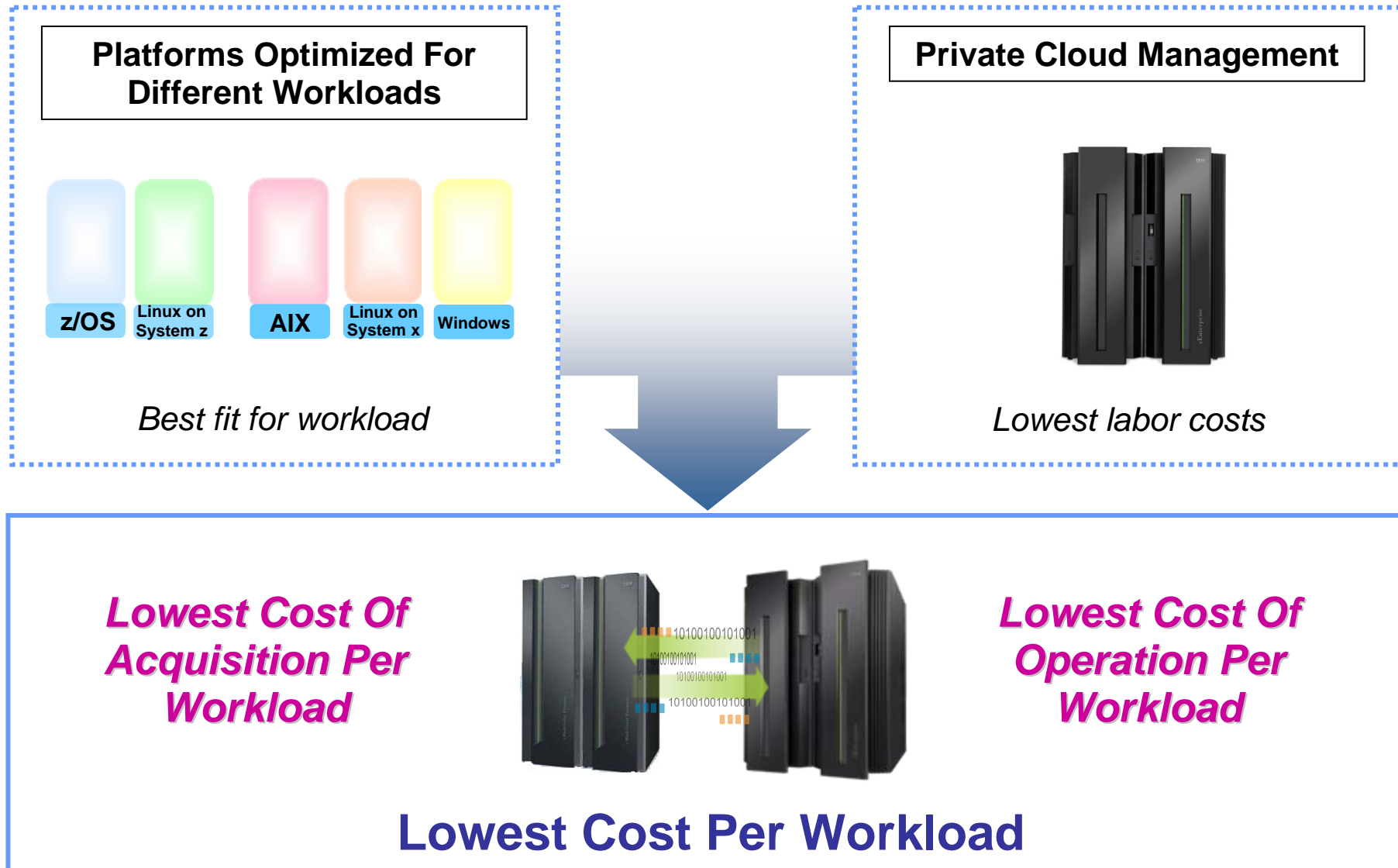

# zEnterprise Provides A Variety Of Platforms For All Workloads

Use a Best Fit Strategy for Workload Assignment

*POWER7  
Blades*



*System x Blades*

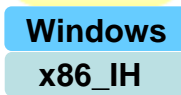
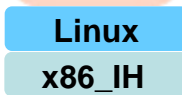

*Optimizer  
Blades*

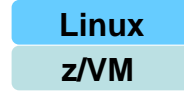
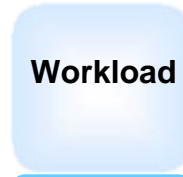
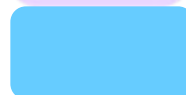

*Specialty  
Appliances*

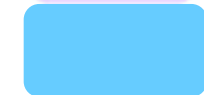

**zEnterprise BladeCenter  
Extension (zBX)**



+

**z196 / z114**



+

**IBM DB2 Analytics  
Accelerator**



# zEnterprise 196 – The Fastest, Most Capable Mainframe To Date



*z10 Enterprise Class*



*zEnterprise 196 (z196)*

<i>Clock speed</i>	4.4 GHz	➤	<b>5.2 GHz</b>
<i>Processors per MCM</i>	5	➤	<b>6</b>
<i>Total processors</i>	77 (64 configurable)	➤	<b>96 (80 configurable)</b>
<i>Total Memory</i>	1.5 TB	➤	<b>3TB</b>
<i>Core performance**</i>	920 MIPS	➤	<b>1,202 MIPS</b>
<i>Total Capacity*</i>	30,657 MIPS	➤	<b>52,286 MIPS</b>
<i>Power per MCM</i>	1800 W	➤	<b>1800 W</b>

• Based on LSPR ratings for fully configured system

\*\* Single process performance

# zEnterprise BladeCenter Extension (zBX) Adds New Platforms To System z

- zBX ordered and installed as one fully built and tested System z “part”
  - ▶ Includes all necessary components – switches, chassis, power, and cabling
  - ▶ Blades and optimizers purchased separately
- Built from standard IBM Certified Components
- Full redundancy insures highest reliability
- System z product support for problem reporting, hardware and firmware updates



**One zBX rack:**

- Up to 14 single-width blades per chassis
- Up to 2 chassis per rack

**One fully loaded zBX is:**

- 4 racks
- 112 blades

**Selected IBM blades supported:**

- IBM POWER7 blades
- IBM System x blades
- Specialty Optimizer
- Most can be mixed



# Add IBM DB2 Analytics Accelerator For Even Better Performance

Complex queries run significantly faster with IBM DB2 Analytics Accelerator

Query	DB2 (Secs)	DB2 + IDAA (Secs)	Speed Up	Rows Reviewed	Rows Returned
Query 1	9,540	5	1,908x	2,813,571	853,320
Query 2	8,220	5	1,644x	2,813,571	585,780
Query 3	4,560	6	760x	8,260,214	274
Query 4	4,080	5	816x	2,813,571	601,197
Query 5	4,080	70	58x	3,422,765	508
Query 6	3,180	6	530x	4,290,648	165
Query 7	3,120	4	780x	361,521	58,236
Query 8	2,640	2	1,320x	342,529	724
Query 9	2,520	193	13x	4,130,107	137



*“We had this up and running in days with queries that ran over 1000 times faster”*

*“We expect ROI in less than 4 months”*

# How To Make The Best Use Of System z To Reduce Costs

- Survey workloads for best assignments

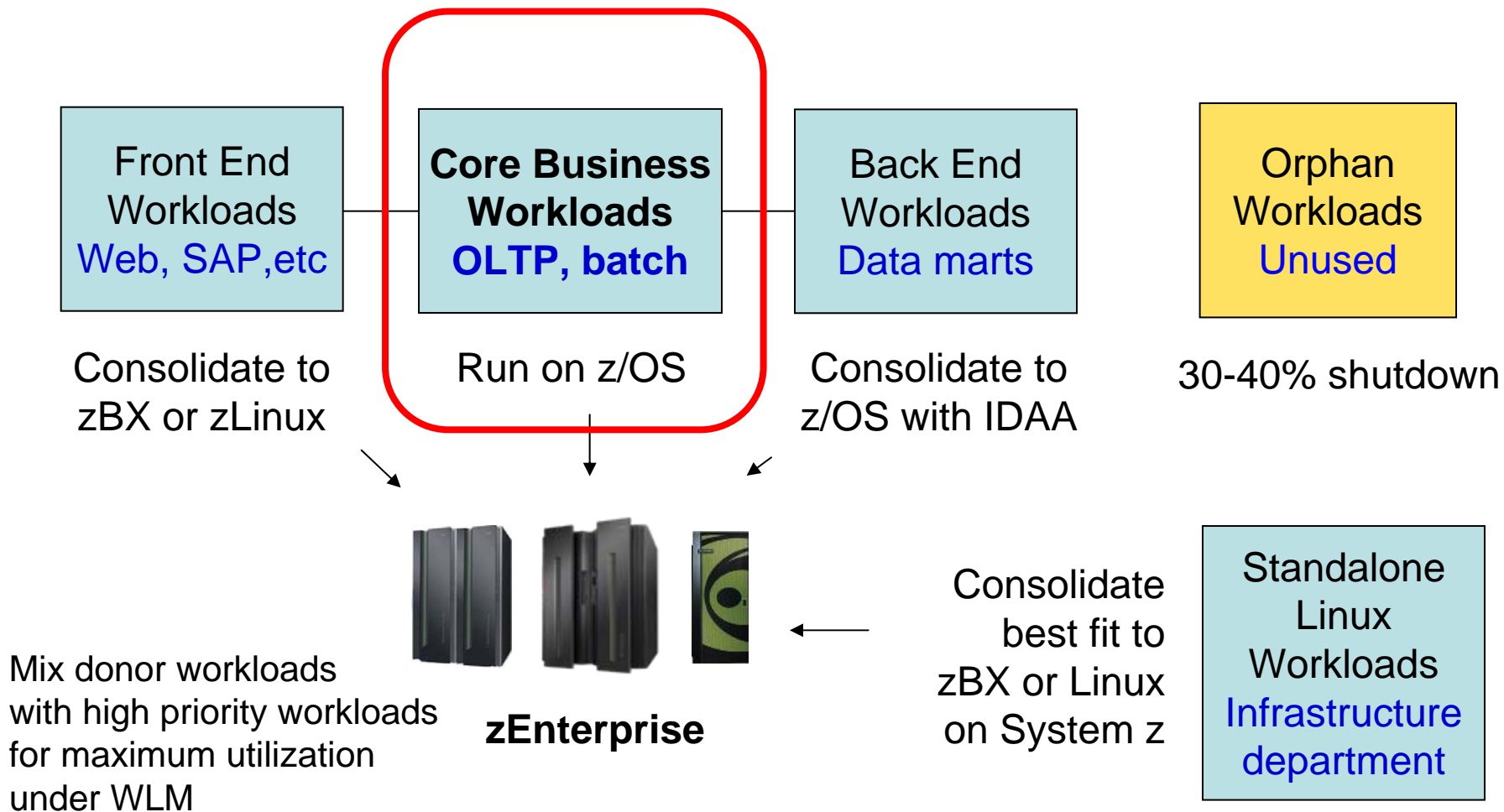

# Core Business Workloads Are Fit Best On System z

- System z is optimized for real-world **transaction processing** workloads
  - ▶ Online and batch
  - ▶ DB2 on z/OS beats Oracle in price/performance
- System z is optimized to run **multiple workloads** thereby enabling higher levels of utilization
  - ▶ Consolidating SAP Databases on z/OS beats Oracle in price/performance
- System z is optimized to run **business analytics**
  - ▶ Co-locating data marts on z/OS reduces costs
  - ▶ IBM DB2 Analytics Accelerator (IDAA) beats Exadata hands down!

# Surveys Confirm Mainframes Are Lowest Cost For Core Business Workloads

Industry	Measure	Average IT Cost of Goods	Mainframe Biased	Distributed Biased	% Mainframe Cost Less Than Distributed
Bank	Per Teller Transaction	\$0.31	\$0.12	\$0.35	66%
Mortgage	Per Approved Loan	\$263.67	\$98.38	\$290.80	66%
Credit Card	Per Transaction	\$0.16	\$0.10	\$0.18	44%
Railroads	Per Ton Mile	\$0.0014	\$0.0012	\$0.0018	33%
Armed Service	Per Person	\$8,036	\$6,871	\$9,839	30%
Automotive	Per Vehicle	\$333	\$275	\$370	26%
Retail	Per Store (Door)	\$494,818	\$421,346	\$560,300	25%
Utilities	Per MegaWatt Hour	\$2.63	\$2.21	\$2.94	25%
Hospitals	Per Bed per Day	\$64.30	\$54.4	\$71.7	24%
Oil & Gas	Per Barrel of Oil	\$2.10	\$1.78	\$2.32	23%
Consulting	Per Consultant	\$53,060	\$48,900	\$62,344	22%
Trucking	Per Road Mile	\$0.177	\$0.155	\$0.194	20%
Airlines	Per Passenger Mile	\$0.007	\$0.0061	\$0.0076	20%
Chemicals	Per Patent	\$57,717	\$55,800	\$59,552	6%
Web Sites	Per Search	\$0.042	\$0.046	\$0.041	-12%

**Most businesses running core workloads on mainframes had 6% to 66% lower IT costs per good than those using distributed servers**

# System z Balanced Optimization Technologies Yield Best Performance With Most Efficiency

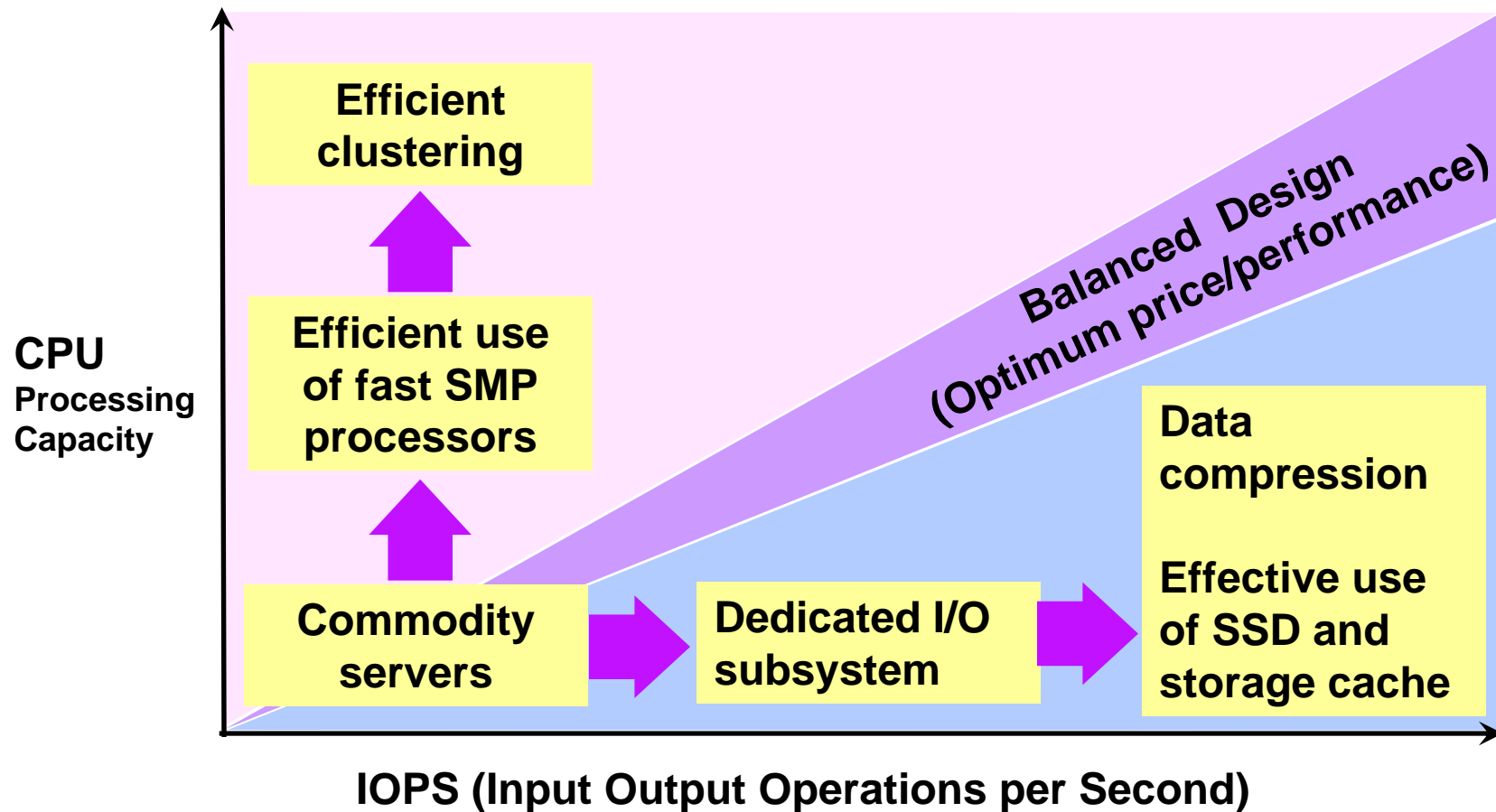

# System z Is Uniquely Architected To Support Very Large Scalability Rates

- More processors, memory and cache than other enterprise servers
- I/O offloaded to dedicated processors for extreme efficiency
- Up to 32 can be clustered in a parallel sysplex
- Result:
  - ▶ Potential sysplex scale to over 1,300 BIPS
  - ▶ Near-linear
  - ▶ Optimized for heavy I/O workloads

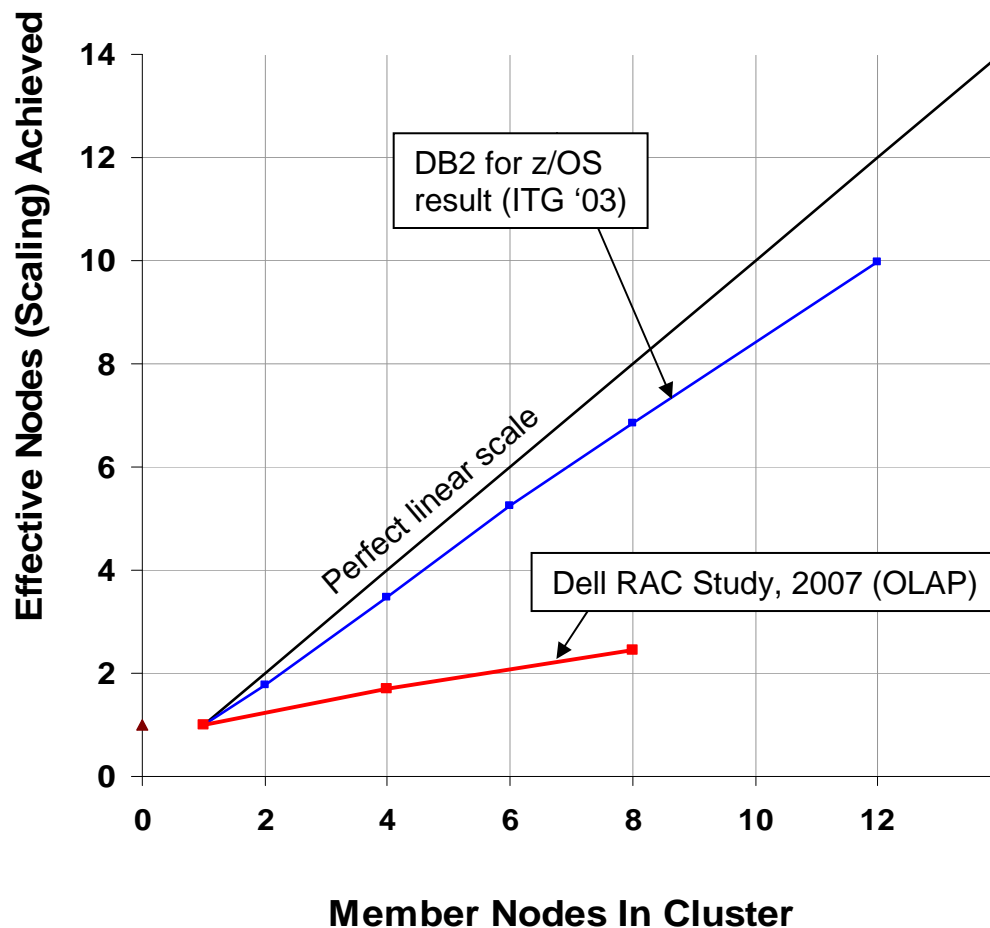

# System z I/O Subsystem Helps Achieve Higher Density For Workloads With Heavy I/O

## Comparison of consolidation platforms

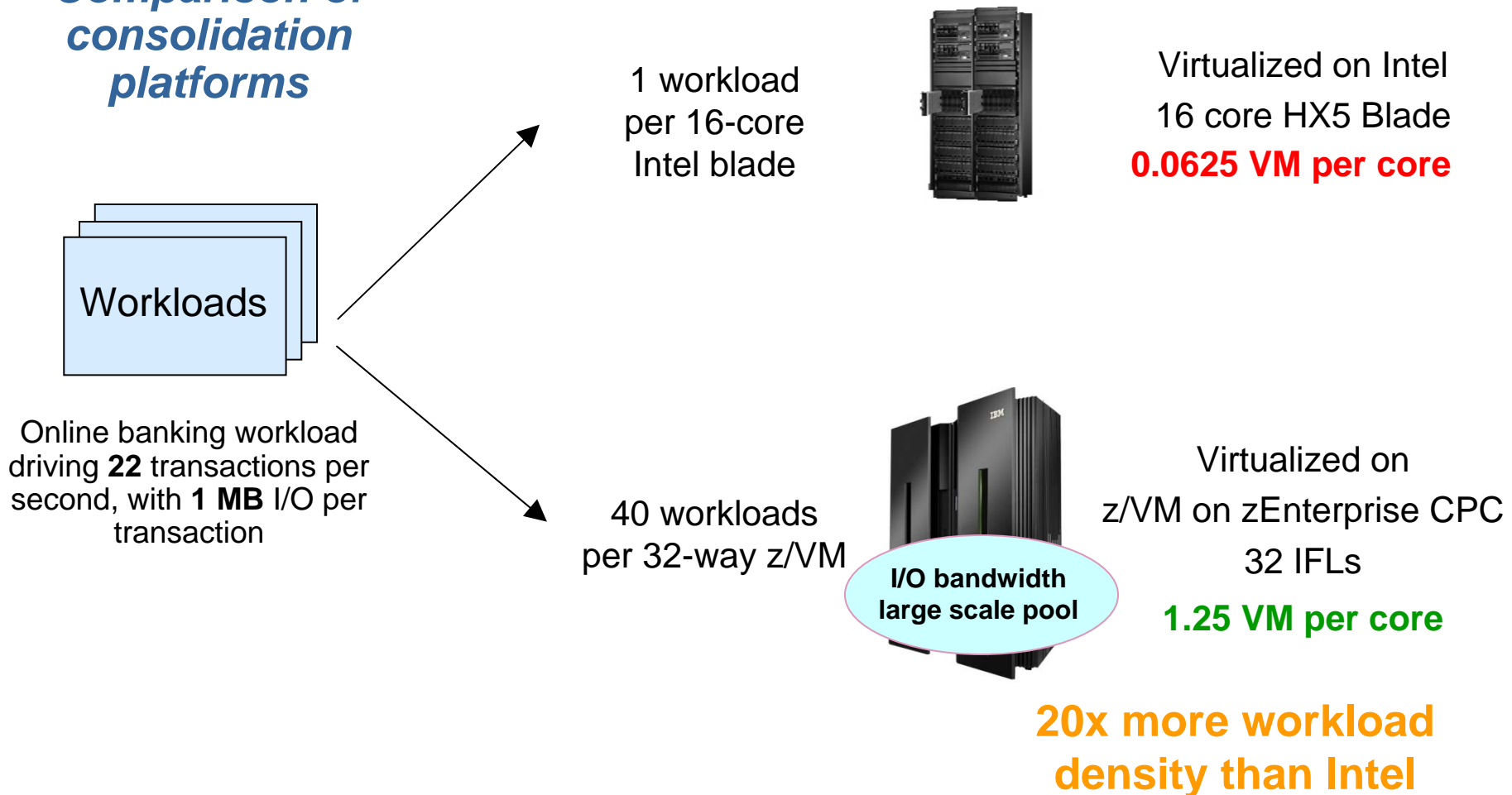

Results may vary based on customer workload profiles/characteristics.

# Batch Sort/Merge Comparison – Demonstrates I/O Bandwidth Capacity

## Intel x3550 + DS8300

12 processors  
128 GB RAM

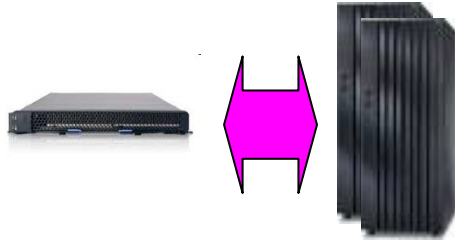

Sorting  
Average CPU  
89%

## z/OS + DS8800

8 z196 processors  
128 GB RAM



Sorting  
Average CPU  
72%

**SORT** Job: Sort a 3 GB transaction file – Repetitions: 300

Sorting Total Elapsed 28,800 secs  
Bytes Per Sec **64 MB**

Sorting Total Elapsed 644 secs  
Bytes Per Sec **3,072 MB**

**48x  
more I/O  
bandwidth  
than Intel**

**MERGE** Job: Merge 30 sorted files into a 90 GB master file – Repetitions: 10

Merging Total Elapsed 16,800 secs  
Bytes Per Sec **109 MB**

Merging Total Elapsed 558 secs  
Bytes Per Sec **3,543MB**

**Intel Batch window is 38x longer than z/OS**

Source: IBM Internal Study. Results may vary based on customer workload profiles/characteristics.



# Real-World Benchmarks Show DB2 For z/OS Delivers Better Performance Than Oracle On HP

## System z and BaNCS Online Banking Benchmarks

### ■ Kookmin Bank

- ▶ IBM System z and DB2
- ▶ TCS BaNCS
- ▶ 15,353 Transactions/second
- ▶ 50 Million Accounts
- ▶ IBM benchmark for customer
- ▶ DB2 V9, CICS 3.1, z/OS V1.8

### ■ State Bank of India<sup>1</sup>

- ▶ HP Superdome
- ▶ TCS BaNCS
- ▶ 10,716 Transactions/second
- ▶ 500 Million Accounts
- ▶ Largest banking benchmark performance claimed by HP

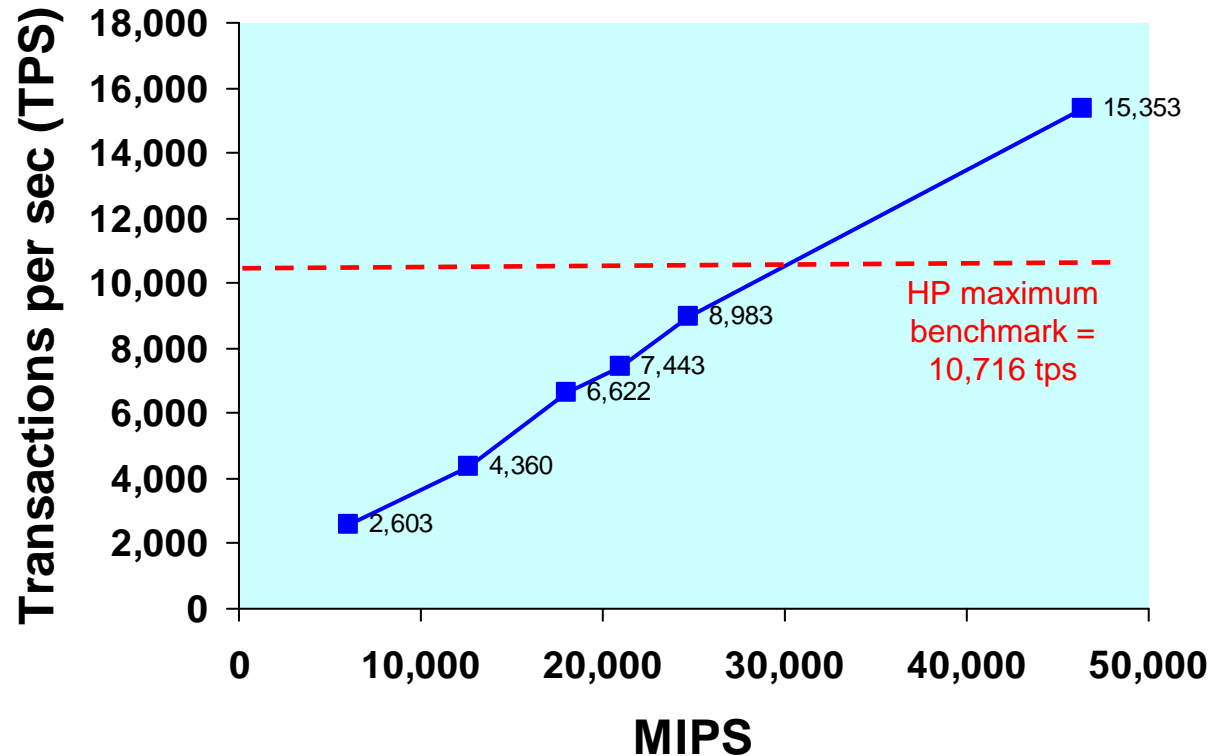

<sup>1</sup> Source: <http://www.enterprisenetworksandservers.com/monthly/art.php?2976> and *InfoSizing FNS BANCS Scalability on IBM System z – Report Date: September 20, 2006*; Clement Report; <http://h20195.www2.hp.com/v2/GetPDF.aspx/4AA1-4027ENW.pdf> Feb 2010

# Compare The Cores Needed To Achieve Equivalent Throughput (10,716 Transactions Per Second)

BaNCs Application Servers:  
8x HP Superdome (16ch/22co)

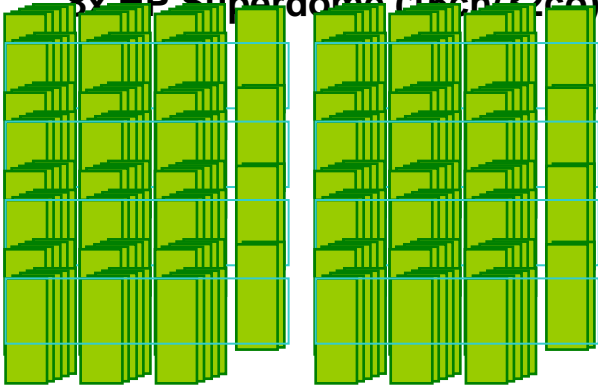

BaNCs Database Servers:  
4x HP Superdome (24ch/48co)

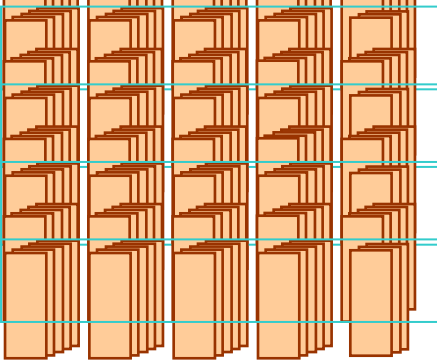

37 processors  
(31 GPs + 6 zIIPs)  
(30,837 MIPS)



448 Intel  
processors

TCS BaNCs  
1x z196-731  
with 6 zIIPs



**System z delivers  
equivalent performance  
with 92% fewer cores**

# Processor Proliferation Drives Up The Cost Of The HP Solution

## Development and Test processors included

BaNCS Application Servers:  
16x HP Superdome (16ch/32co)

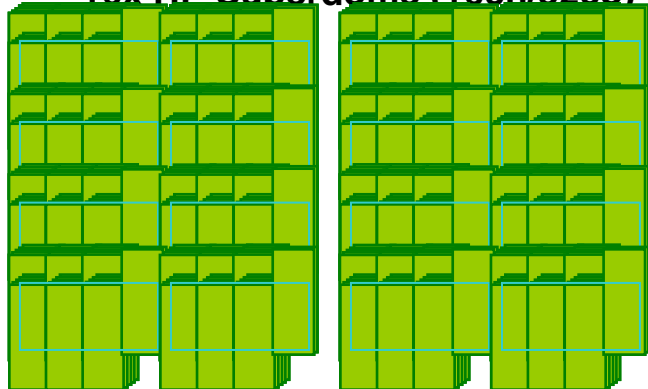

BaNCS Database Servers:  
16x HP Superdome (16ch/32co)

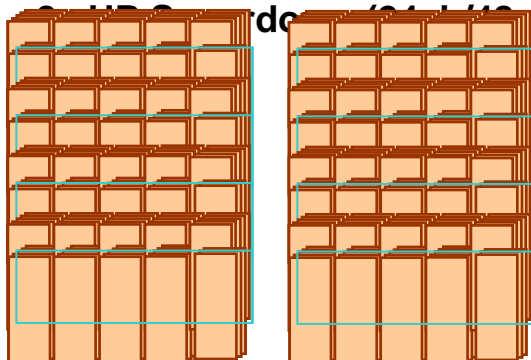

**Total (5yr TCA) \$180M**

49 processors  
(41 GPs + 8 zIIPs)  
(39,112 MIPS)

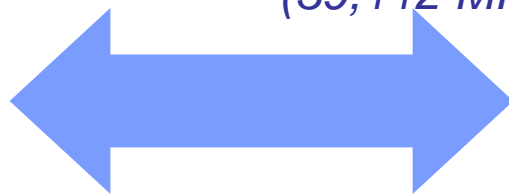

896 processors  
(3,668,600 PerfUnits)

TCS BaNCS  
1x z196-741  
with 8 zIIPs



Hardware	\$98.2M
Software	\$78.2M
Power	\$1.5M
Space	\$1.1M

Hardware	\$64.2M
Software	\$45.6M
Power	\$0.13M
Space	\$0.08M

**Total (5yr TCA) \$110M**

NOTE: To cover DEV/QA capacity, add 100% servers for distributed servers, add 25% MIPS (8,000) to System z

# Large Systems With Centralized Management Deliver Better Labor Productivity

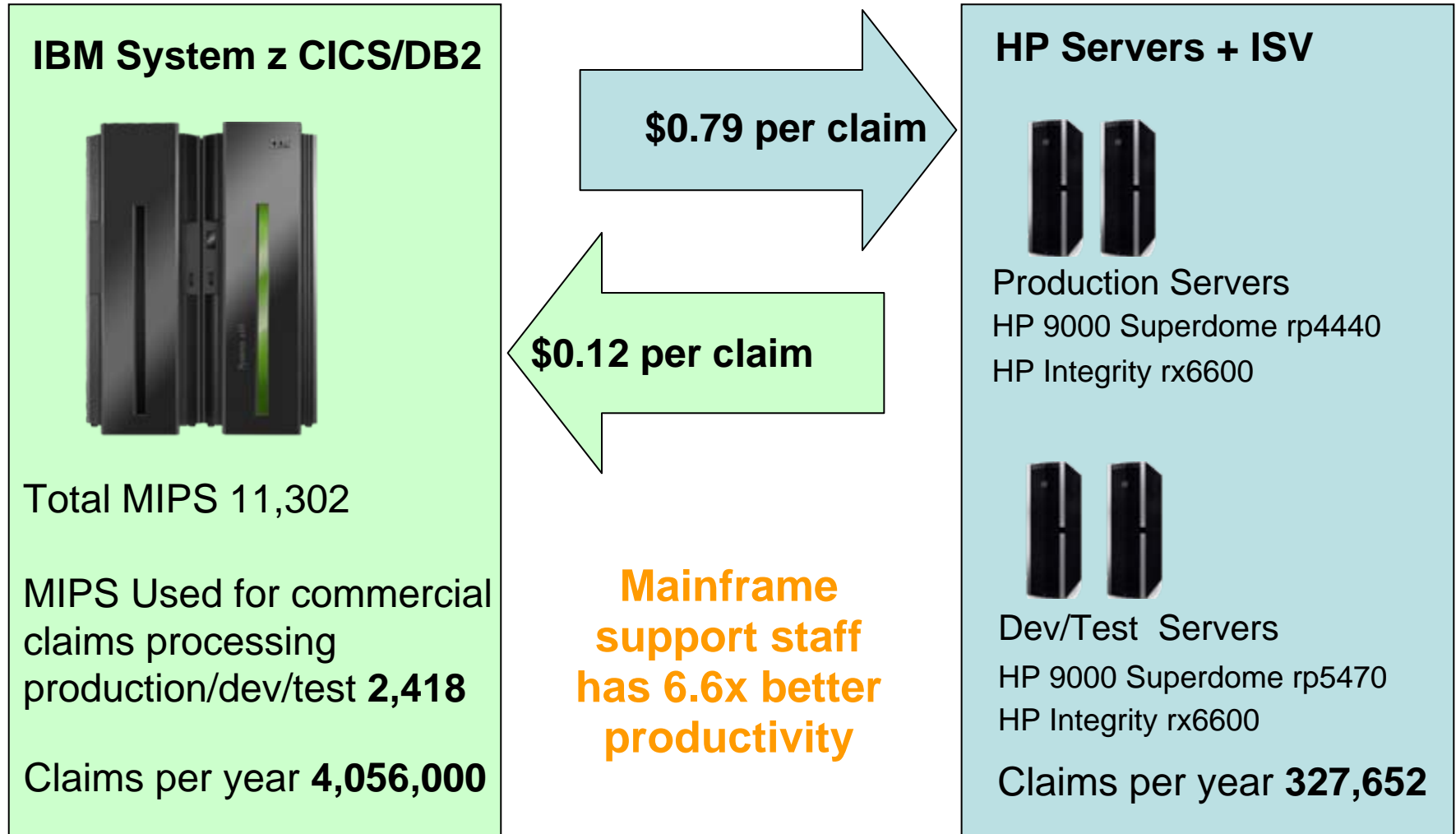

# Constant Optimizations - CICS/DB2 From Then To Now

Continued investment in optimization of key z/OS software

1. Upgraded CICS/DB2 stack produces 1.49x performance improvement
2. Move to z196 hardware produces 1.35x performance improvement
3. Upgrade to latest software produces 1.12x improvement
4. Combined hardware and software updates – **2.25x** performance improvement

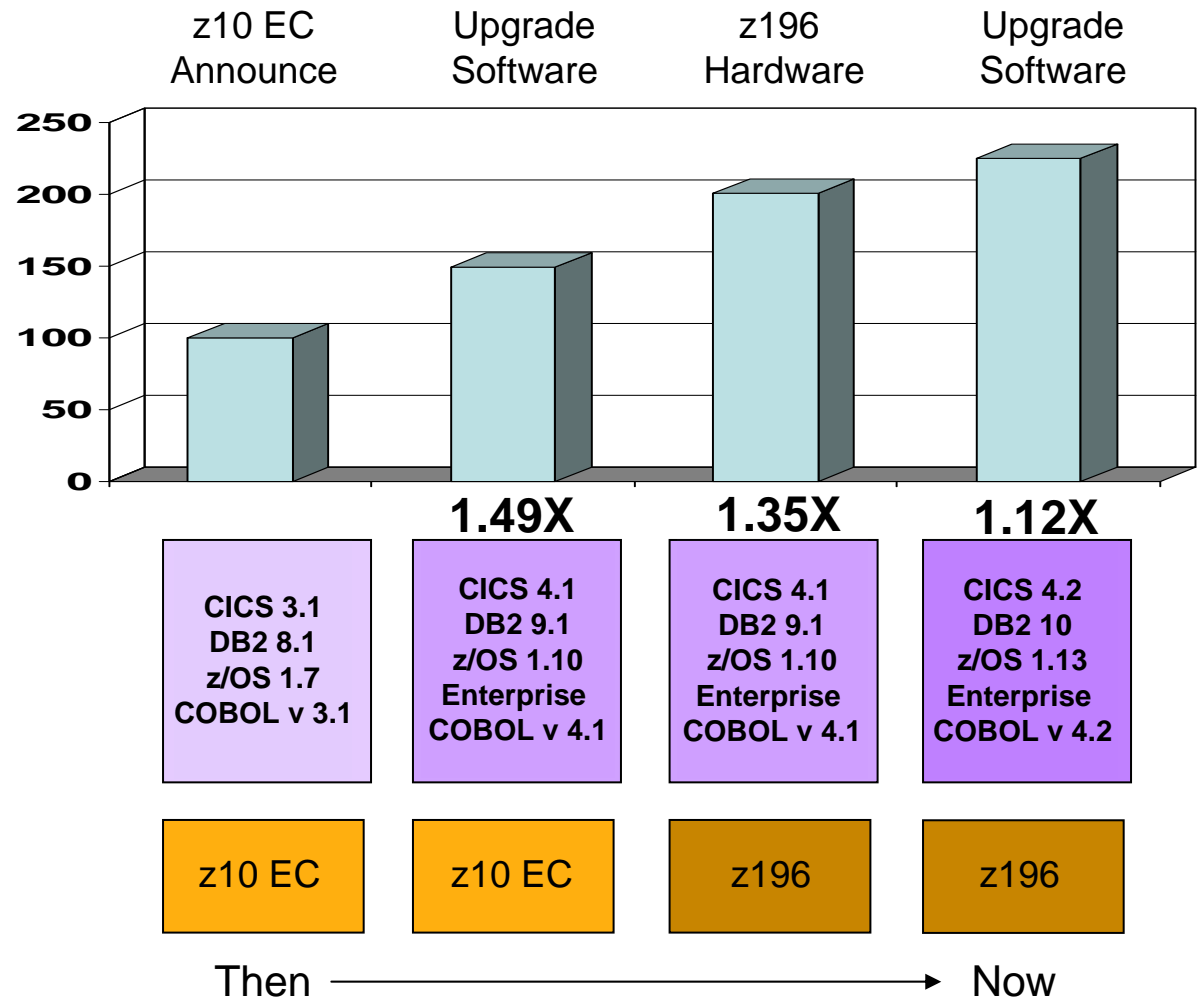

# European Bank Study – Consolidating SAP On DB2

## Six SAP databases, Oracle on Intel

2 x 100% Production and Pre-production with active/passive failover; 18% Dev/QA, no failover

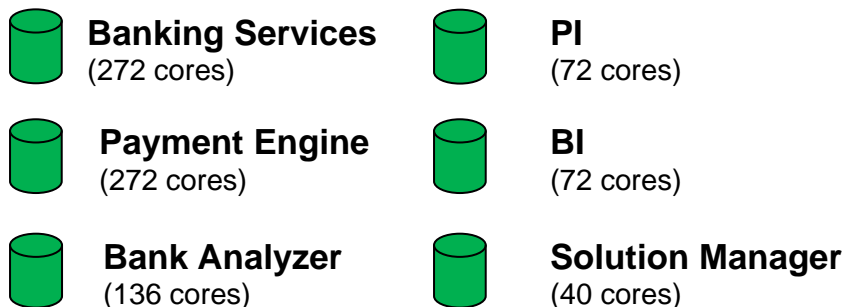

30 x HP DL Servers X7560 2.27GHz with Oracle

**864 cores**

**Total** (5yr TCA)      **\$97.2M**

Hardware	\$3,097,858
Software	\$92,908,752
Networking	\$1,185,000

## Multi-Tenancy, DB2 on z/OS

Consolidated Databases DB2 for z/OS Sysplex  
100% Production, 33% Pre-Production, 18% Dev/QA

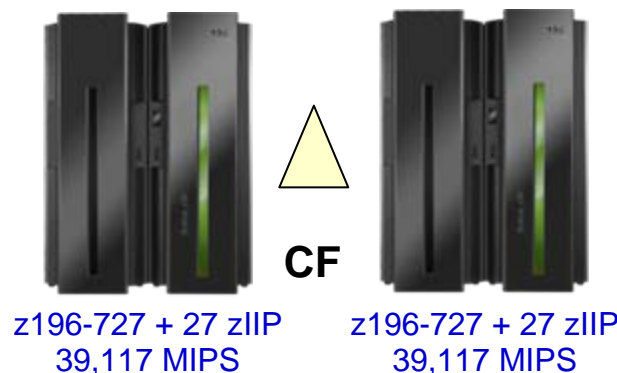

**108 cores**

**88% less**

**Total** (5yr TCA)      **\$11.8M**

Hardware & Software (Solution Edition SAP)	\$11,699,122
Networking	\$79,000

6 SAP DB Instances with total Prod. DB QuickSizer SAPS = 177,000 consolidated into DB2 z/OS (multi-tenancy) , Performance Equivalence = 64, US Prices with System z Solution Edition for SAP DB and List Prices for Oracle SW & HP HW. Does not include cost of SAP software.

# Data Mart Proliferation At A Local Government Department

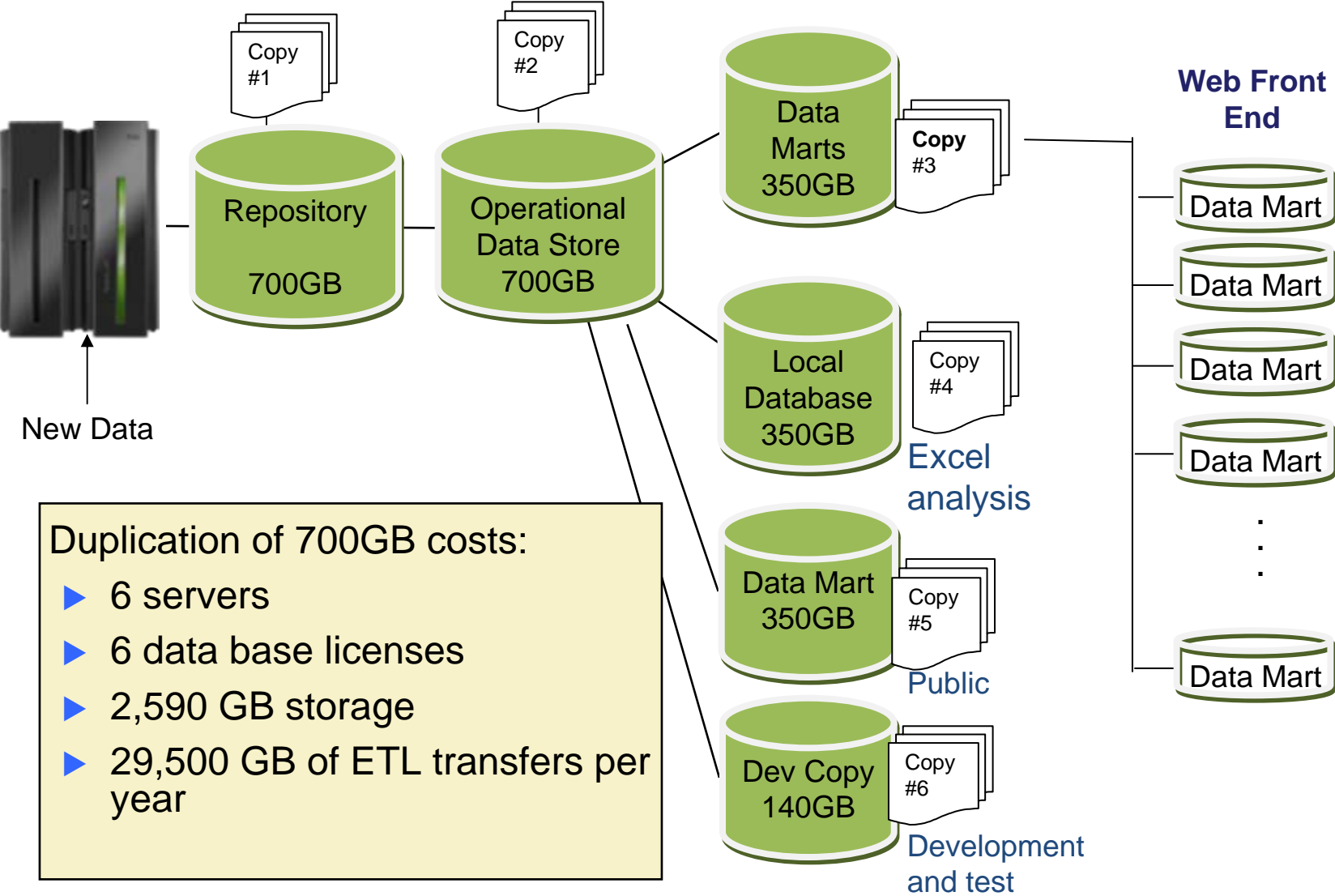

Duplication of 700GB costs:

- ▶ 6 servers
- ▶ 6 data base licenses
- ▶ 2,590 GB storage
- ▶ 29,500 GB of ETL transfers per year

# Compare Cost Of Standalone Data Mart To Incremental Cost Of Consolidating On System z

## Standalone Competitor

Quarter Rack



Unit Cost (3yr TCA) **\$97/RpH**

Reports/Hour (RpH)	29,572
Competitor ¼ Rack (HW+SW+Storage)	\$2,857,500

## IBM Smart Analytics System 9700

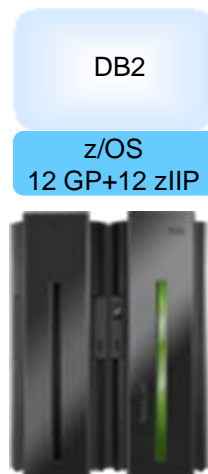

Unit Cost (3yr TCA) **\$62/RpH**

Reports/Hour (RpH)	57,904
IBM Smart Analytics System 9700 24-cores (HW+SW+Storage)	\$3,600,000

## IBM Smart Analytics System 9700 + IDAA

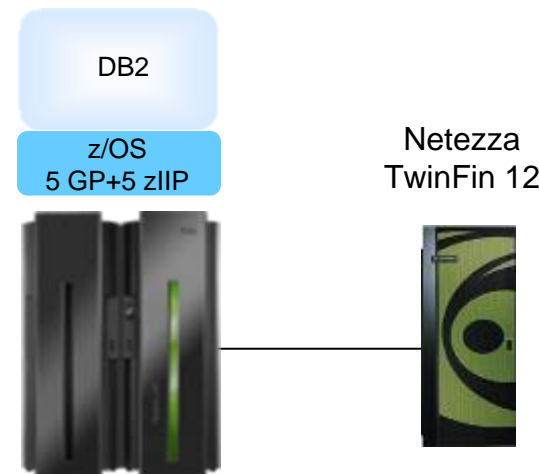

Unit Cost (3yr TCA) **\$24/RpH**

Reports/Hour (RpH)	154,893
IBM Smart Analytics System 9700 10-cores (HW+SW+Storage)	\$1,500,000
IDAA (HW+SW+Storage)	\$2,140,600

**5x performance at ¼ the cost!**

Source: Customer Study running 161,166 concurrent operational reports. Intermediate/Complex Reports offloaded to IDAA for serial execution. Results may vary based on customer workload profiles/characteristics.



# System z Active Workload Manager Handles Workload Peaks For Optimum Core Efficiency

Example: Core banking workloads running simultaneously on z/OS with high utilization

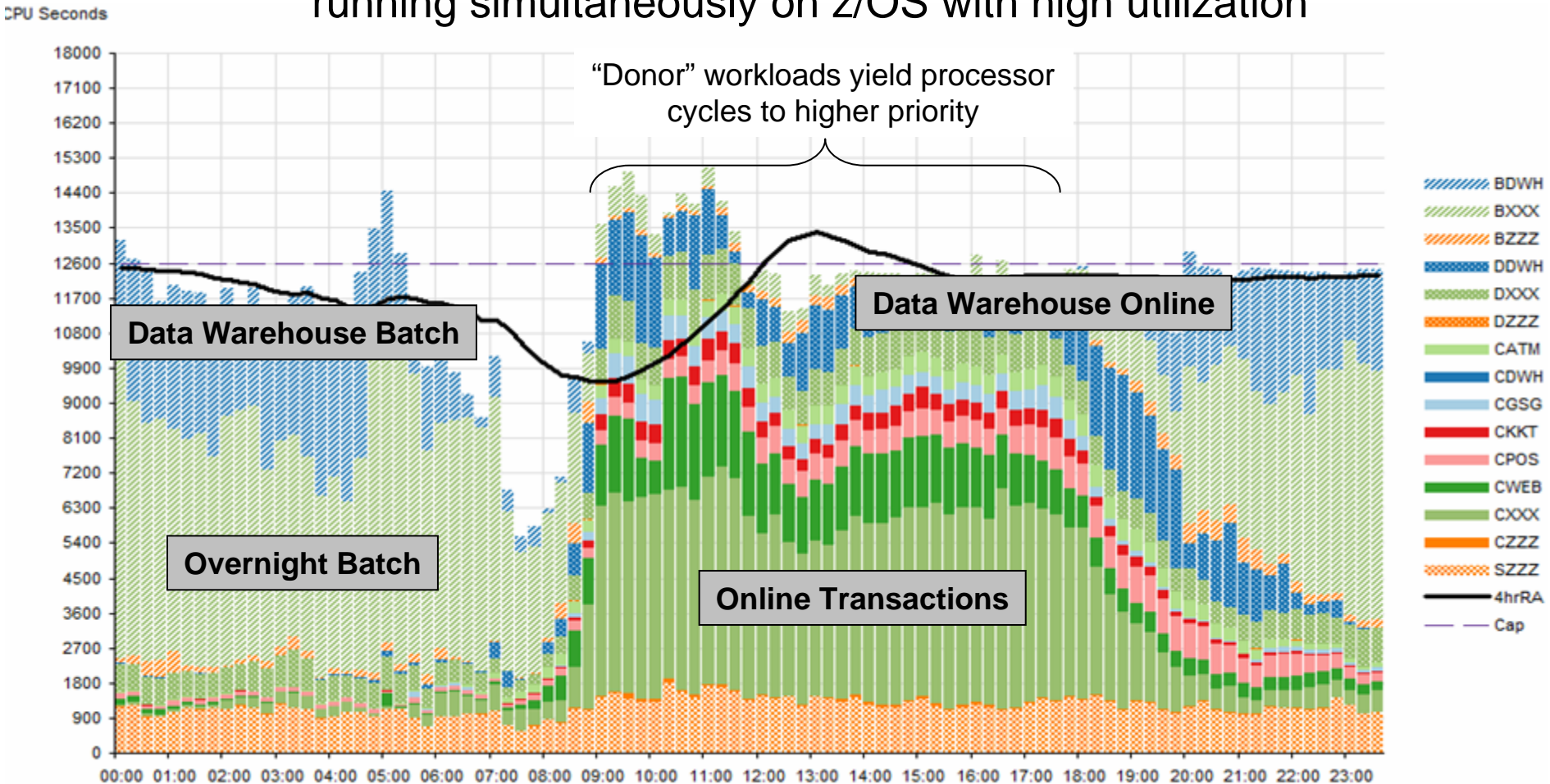

# System z Workload Management Can Mix OLTP And Analytics On The Same Platform

- Existing OLTP workload is the business priority
  - ▶ Service level agreement must be maintained at 800 tps
- Add new business analytics workload in a separate LPAR
  - ▶ Balanced core across both LPARs to maintain OLTP SLA
- Both workloads execute simultaneously while maintaining OLTP service level
- **z196 optimized workload management avoids OLTP degradation**

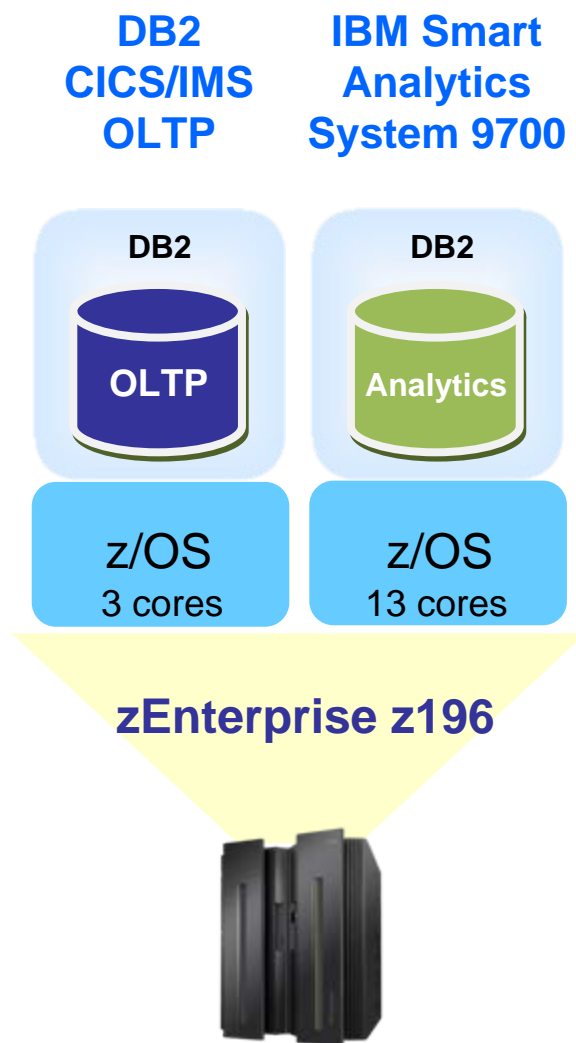

# Competitor's Platform Fails To Effectively Manage Mixed OLTP And Analytics Workloads

Competitor  
¼ Rack  
16 cores

**OLTP only**  
Utilization:  
Database 16%  
Storage 11%

**After 4 weeks of tuning** – OLTP workload meets SLA, but Analytic workload must be throttled to keep CPU utilization low on storage servers

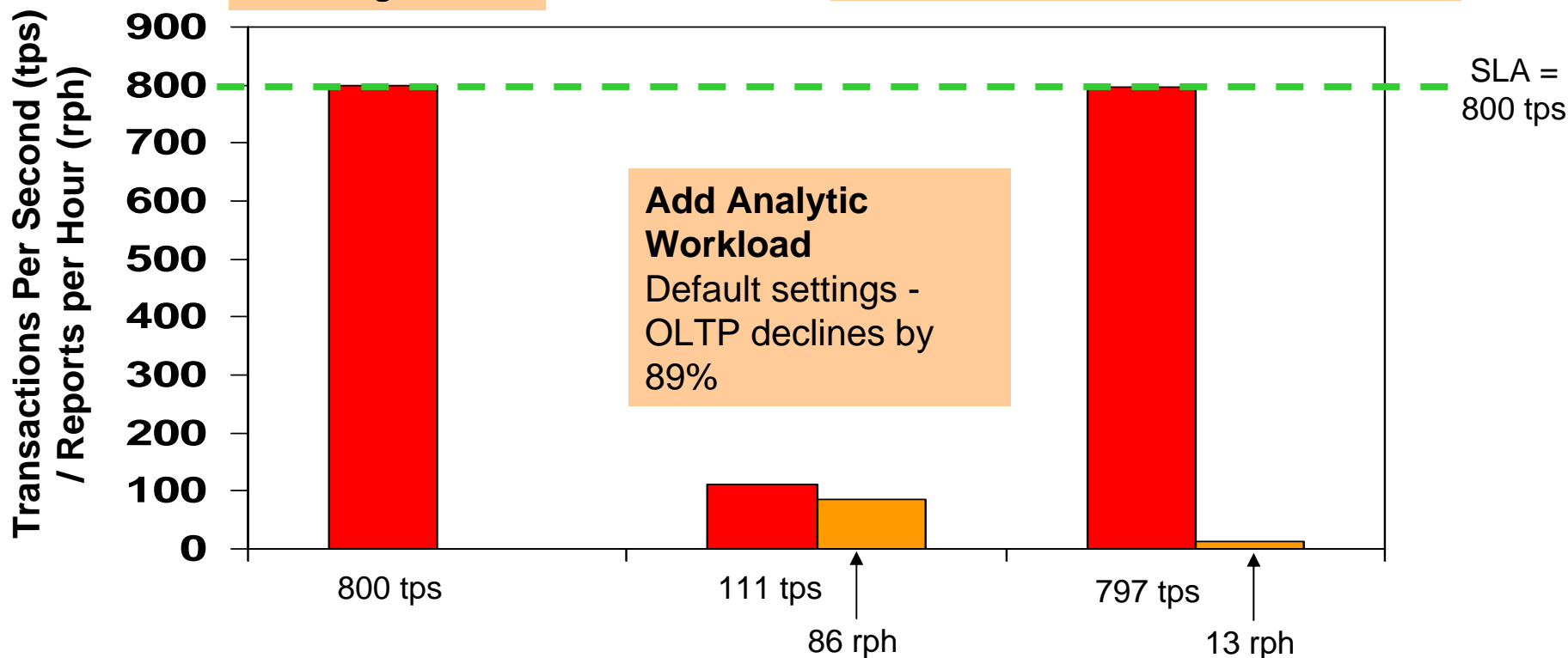





Reports per Hour are Intermediate based on BI Day benchmarks

# System z Capacity On Demand Provides Elasticity To Handle Unexpected Peaks

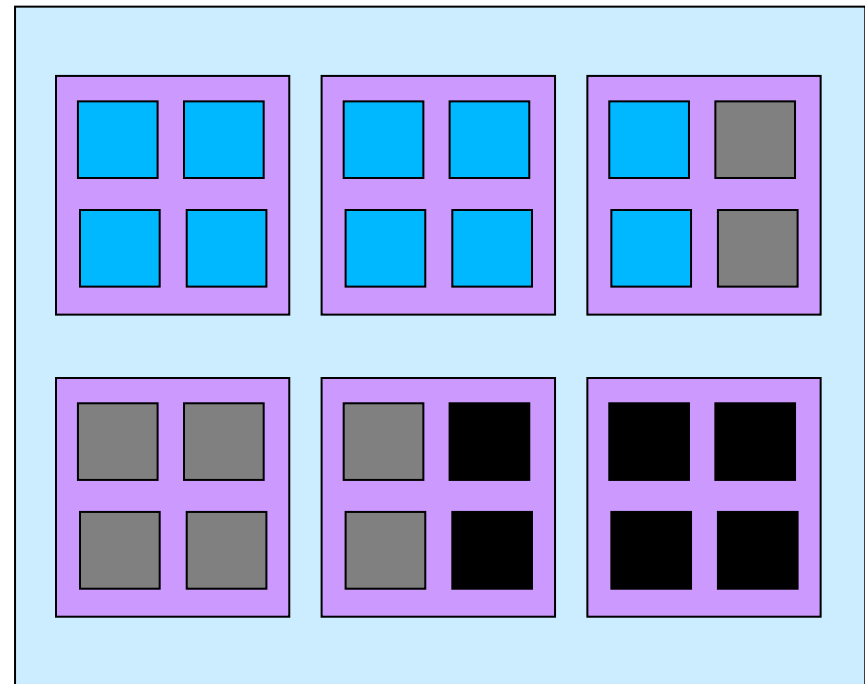
- On/Off Capacity on Demand (On/Off CoD)
  - ▶ Flexible, easy, temporary additional capacity
  - ▶ Self-managed
  - ▶ Total flexibility within number of books installed
- New capacity is immediately available for work without service disruption
- Can be automated

One Book with 24 Processors



-  Active processors – pay full price
-  Inactive processors (On/Off CoD) – pay only 2% of full price
-  Dark processors (unused) – no charge

# A Complex Scale Out Of Distributed Servers Has Its Risks

North America	Europe	Asia Pacific		Apr 26	Apr 25	Apr 24	Apr 23	Apr 22	Apr 21	Apr 20	
Amazon CloudFront				✓	✓	✓	✓	✓	✓	✓	
Amazon CloudWatch (N. California)				✓	✓	✓	✓	✓	✓	✓	
Amazon CloudWatch (N. Virginia)				✓	✓	⚠	⚠	⚠	⚠	✓	
Amazon EC2 (N. California)				✓	✓	✓	✓	✓	✓	✓	
Amazon EC2 (N. Virginia)				✓	⚠	⚠	✖	✖	✖	✓	
Amazon EMR (N. California)				✓	✓	✓	✓	✓	✓	✓	
Amazon EMR (N. Virginia)				✓	✓	✓	⚠	⚠	⚠	✓	
Amazon Flexible Payments Service				✓	✓	✓	✓	✓	✓	✓	
Amazon Mechanical Turk (Requester)				✓	✓	✓	✓	✓	✓	✓	
Amazon Mechanical Turk (Worker)				✓	✓	✓	✓	✓	✓	✓	
Amazon RDS (N. California)				✓	✓	✓	✓	✓	✓	✓	
Amazon RDS (N. Virginia)				✓	⚠	⚠	✖	✖	✖	✓	
Amazon Route 53				✓	✓	✓	✓	✓	✓	✓	
Amazon Simple Email Service (N. Virginia)				✓	✓	✓	✓	✓	✓	✓	
Amazon SNS (N. California)				✓	✓	✓	✓	✓	✓	✓	
Amazon SNS (N. Virginia)				✓	✓	✓	✓	✓	✓	✓	
Amazon SQS (N. California)				✓	✓	✓	✓	✓	✓	✓	
Amazon SQS (N. Virginia)				✓	✓	✓	✓	✓	✓	✓	
Amazon S3 (N. California)				✓	✓	✓	✓	✓	✓	✓	
Amazon S3 (US Standard)				✓	✓	✓	✓	✓	✓	✓	
Amazon SimpleDB (N. California)				✓	✓	✓	✓	✓	✓	✓	
Amazon SimpleDB (N. Virginia)				✓	✓	✓	✓	✓	✓	✓	
Amazon VPC (N. Virginia)				✓	✓	✓	✓	✓	✓	✓	
reddit is down.				✓	✓	✓	✓	✓	✓	✓	
				✓	✓	✓	⚠	⚠	⚠	✓	
				✓	✓	✓	✓	✓	✓	✓	
				✓	✓	✓	✓	✓	✓	✓	
				✓	✓	✓	✓	✓	✓	✓	

Amazon public cloud platform suffered a 3+ day outage in April, 2011

- Distributed architecture designed “for durability and availability”
- Yet a complex *single point of failure* negated the advantage of rapid replacement of failed resources
- Numerous customers suffered significant and unrecoverable data loss

# Downtime Effects Sales, Revenue And Customer Satisfaction

## Revenue Impact of Downtime Per Hour

Figure 1 Cost of downtime by industry segment  
Average = \$2.7M

Industry/Sector	Revenue/Hour
Energy	\$1,468,798
Telecommunications	\$4,611,604
Financial	\$8,213,470
Information Technology	\$3,316,058
Insurance	\$2,582,382
Pharmaceuticals	\$2,058,710
Banking	\$1,145,129
Consumer Products	\$989,795
Chemicals	\$1,071,404
Transportation	\$1,463,128

Source: Robert Frances Group 2006

## Business Impact of 10 Minutes Of Downtime

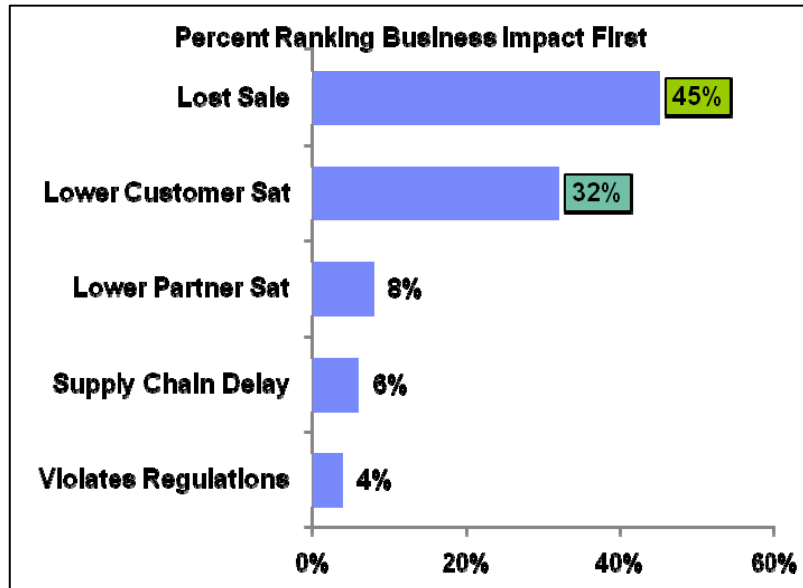

Source: IBM Customer Survey

## Profit Impact of Downtime

A Telco	%	Profit 2009	Profit/Hr	Profit/Min
Wireless	68%	\$3,000,000,000	\$342,466	\$5,708
Cable	29%	\$1,300,000,000	\$148,402	\$2,473
Media	3%	\$120,000,000	\$13,699	\$228
<b>Total</b>	<b>100%</b>	<b>\$4,420,000,000</b>	<b>\$504,566</b>	<b>\$8,409</b>

# Result: zOS Delivers The Highest Availability And The Lowest Downtime Cost

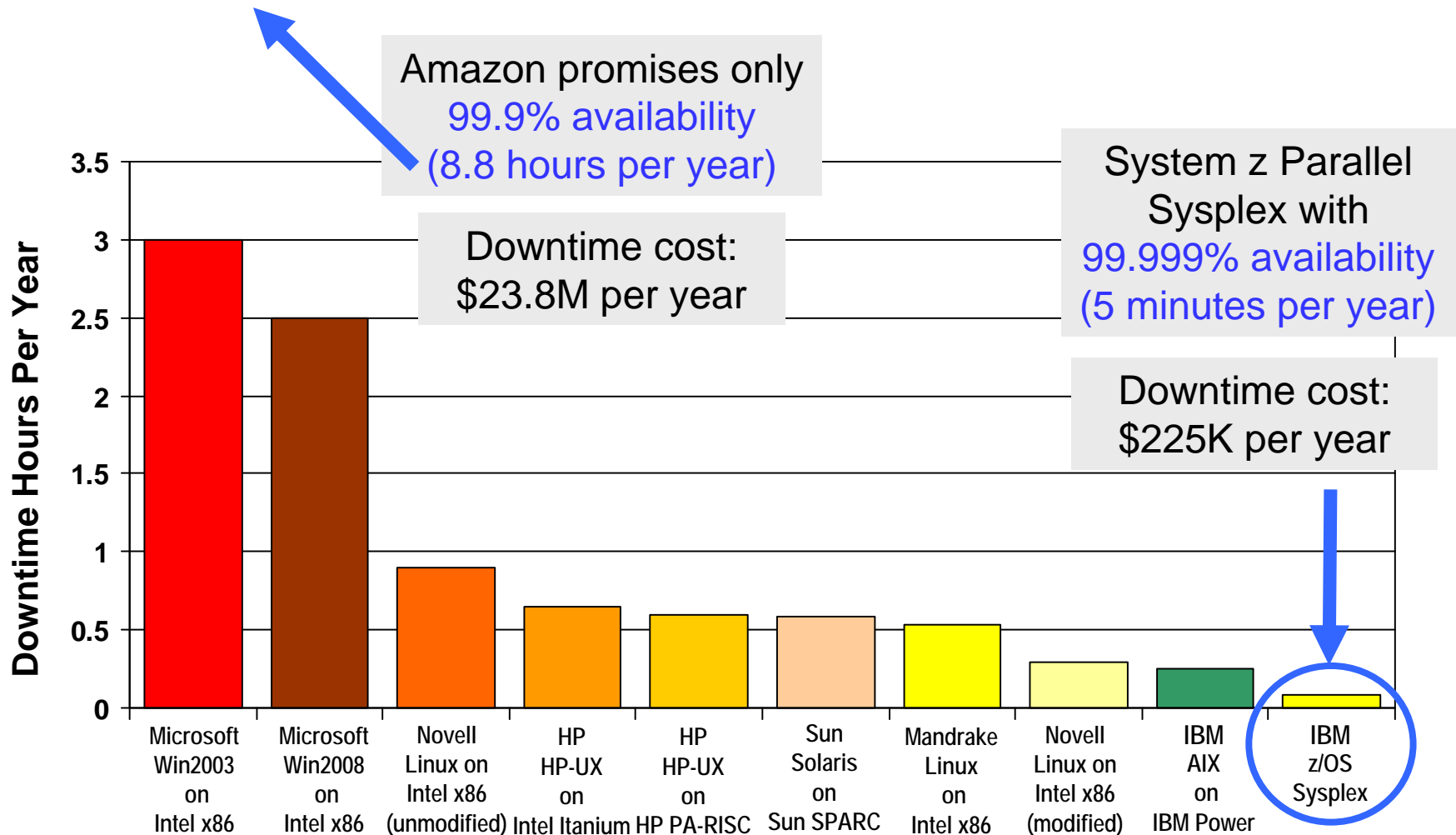

Source: ITIC: ITIC 2009 Global Server Hardware & Server OS Reliability Survey; July 2009; <http://itic-corp.com/blog/2009/07/itic-2009-global-server-hardware-server-os-reliability-survey-results/>; Results are measured in minutes per year. Survey of 400 participants in 20 countries.

\*Note: All operating systems included in the survey are not included in this chart. Fifteen operating systems on various processor architectures were included in the survey. The chart will be updated when the full report is available.

# System z Continues A History Of Mainframe Improvements To Reliability And Serviceability

Comprehensive, multi-layered strategy for reliability and serviceability

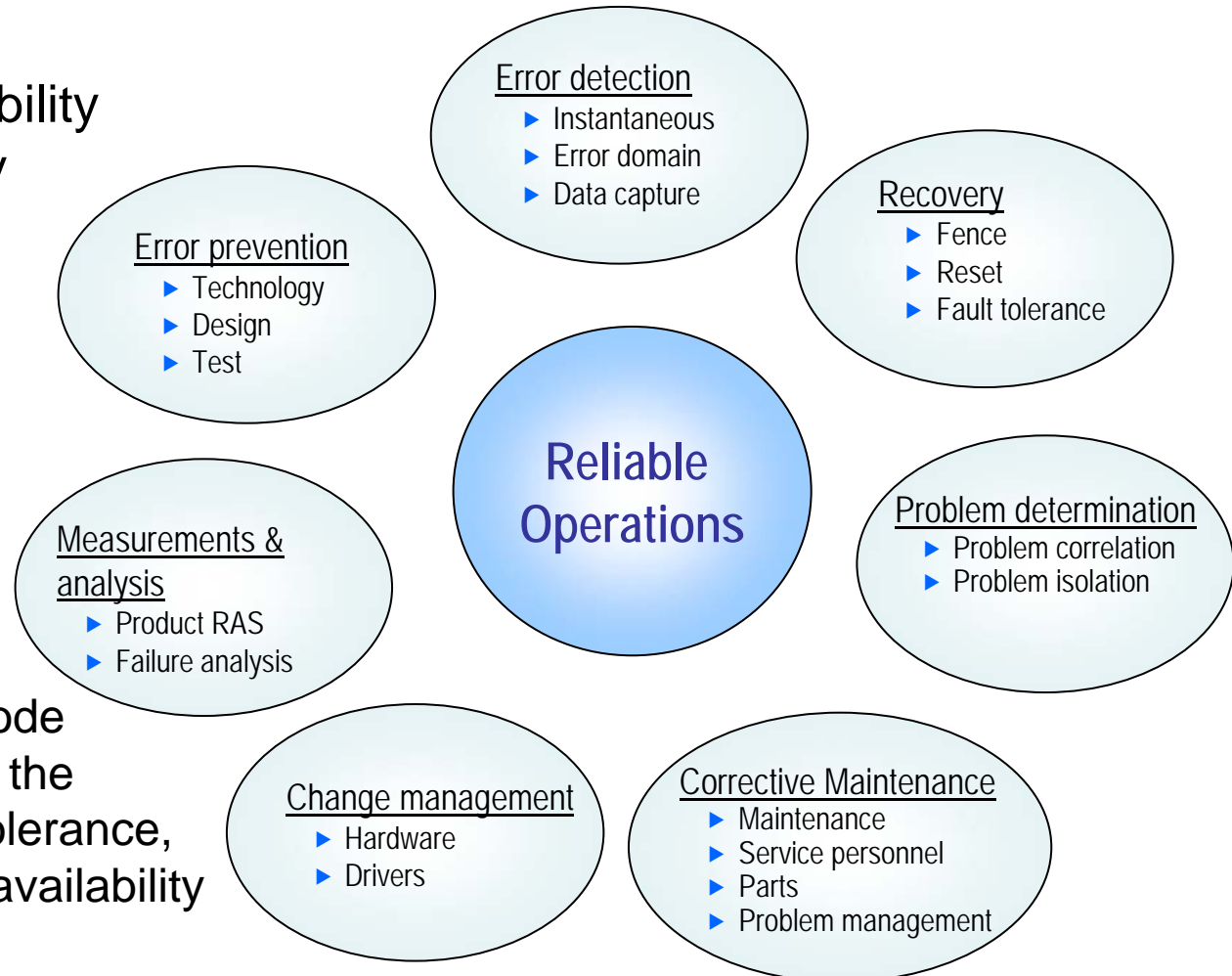

Of ~80M lines of code in z/OS, 50% is for the purposes of fault tolerance, recoverability and availability



# Latest Release Continues This Strategy Of Constant Improvements For Availability

- RAIM memory provides more protection against failure modes
  - ▶ Protects DIMM and memory channel components
  - ▶ More robust than ECC
  - ▶ More cost effective than 100% memory mirroring
  - ▶ No performance penalty
- Hot pluggable I/O drawer technology reduces planned down time
  - ▶ Perform maintenance while the system keeps running

**z196 Book Layout**

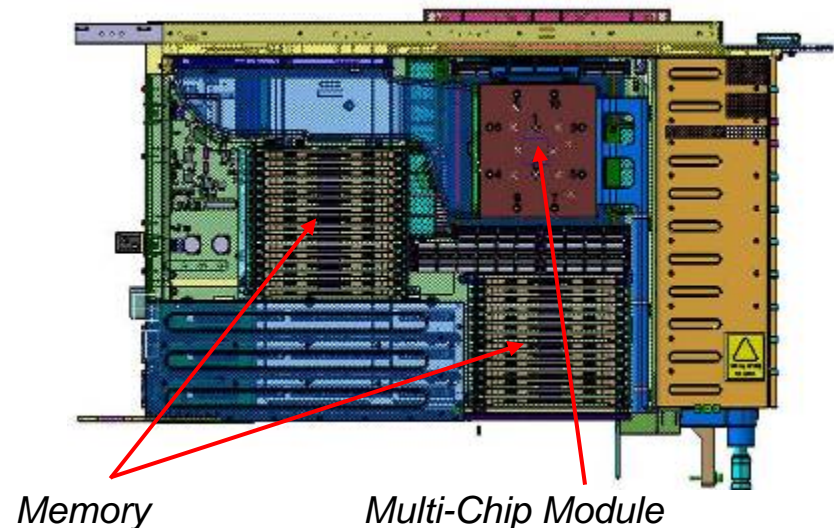

**z196 I/O Drawer (Front)**

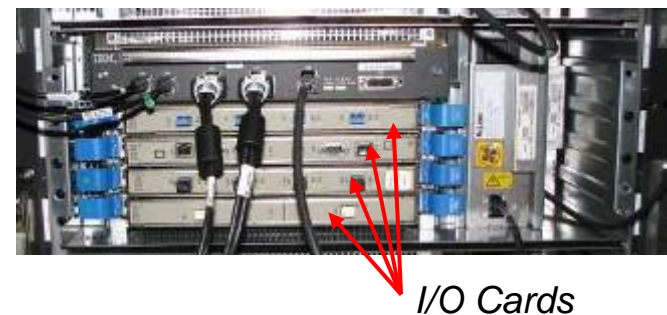

# System z Is Uniquely Optimized For Core Business Workloads

- Extreme scalability coupled with high I/O capability
  - ▶ Optimized for real-world, enterprise-class transaction processing and batch
- Designed with highest reliability and elasticity
  - ▶ Significantly reduced costs of downtime
- Active workload management drives up utilization
  - ▶ Reduces core requirements yielding lower software costs
  - ▶ Consolidate SAP data bases into DB2 multi-tenancy
  - ▶ Solution Edition pricing
- No data movement necessary
  - ▶ Consolidate back end data marts on System z
  - ▶ IDAA is a game changer
- Better administrator productivity

# DEMO: Architecture

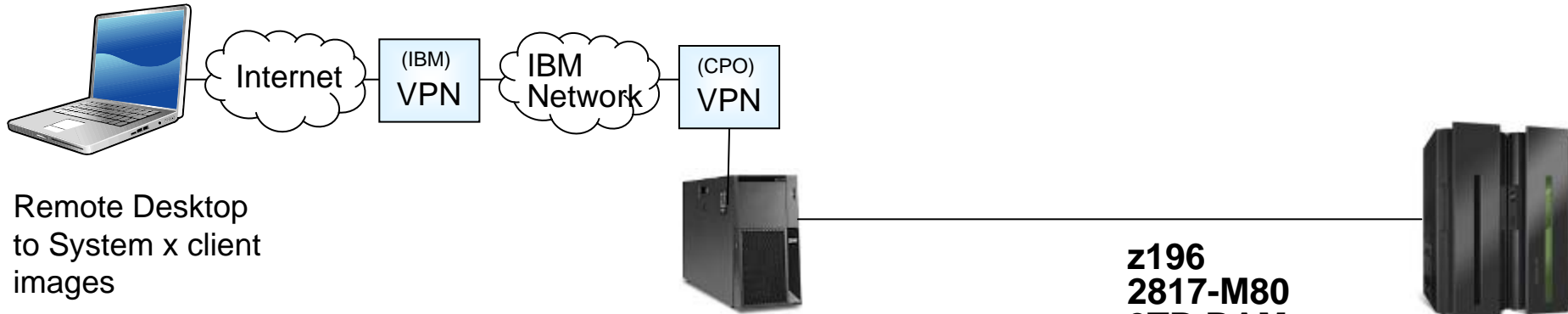

**System x 3950**  
**8 x 3.5GHz Xeon MP**  
**64GB RAM**

System x VMware images running as desktop or server clients to System z



**z196**  
**2817-M80**  
**2TB RAM**

