



Why Linux on IBM System z

Kurt Acker

Bfishing@us.ibm.com

9-16-2008



Trademarks

The following are trademarks of the International Business Machines Corporation in the United States and/or other countries.

APPN*	GDPS*	POWERPC*	Virtual Image Facility
CICS*	Geographically Dispersed Parallel Sysplex	PR/SM	Virtualization Engine
DB2*	HiperSockets	Processor Resource/Systems Manager	VisualAge*
DFSMSMVS	HyperSwap	QMF	VM/ESA*
DFSMS/VM*	IBM*	RACF*	VSE/ESA
DirMaint	IBM eServer	Resource Link	VTAM*
Distributed Relational Database Architecture*	IBM logo*	RMF	WebSphere*
DRDA*	IBMLink	RS/6000*	z/Architecture
e-business logo*	Language Environment*	S/390*	z/OS*
ECKD	MQSeries*	S/390 Parallel Enterprise Server	z/VM*
Enterprise Storage Server*	Multiprise*	System 370	z/VSE
Enterprise Systems Architecture/390*	On demand business logo	System 390*	zSeries*
ESCON*	OS/390*		zSeries Entry License Charge
FICON*	Parallel Sysplex*	System z9	
GDDM*	Performance Toolkit for VM	Tivoli*	
	POWER5	Tivoli Storage Manager	
		TotalStorage*	

The following are trademarks or registered trademarks of other companies.

Java and all Java-related trademarks and logos are trademarks of Sun Microsystems, Inc., in the United States and other countries

Linux is a trademark of Linus Torvalds in the United States and other countries..

UNIX is a registered trademark of The Open Group in the United States and other countries.

Microsoft, Windows and Windows NT are registered trademarks of Microsoft Corporation in the United States and other countries.

* All other products may be trademarks or registered trademarks of their respective companies.

Notes:

Performance is in Internal Throughput Rate (ITR) ratio based on measurements and projections using standard IBM benchmarks in a controlled environment. The actual throughput that any user will experience will vary depending upon considerations such as the amount of multiprogramming in the user's job stream, the I/O configuration, the storage configuration, and the workload processed. Therefore, no assurance can be given that an individual user will achieve throughput improvements equivalent to the performance ratios stated here.

IBM hardware products are manufactured from new parts, or new and serviceable used parts. Regardless, our warranty terms apply.

All customer examples cited or described in this presentation are presented as illustrations of the manner in which some customers have used IBM products and the results they may have achieved. Actual environmental costs and performance characteristics will vary depending on individual customer configurations and conditions.

This publication was produced in the United States. IBM may not offer the products, services or features discussed in this document in other countries, and the information may be subject to change without notice. Consult your local IBM business contact for information on the product or services available in your area.

All statements regarding IBM's future direction and intent are subject to change or withdrawal without notice, and represent goals and objectives only.

Information about non-IBM products is obtained from the manufacturers of those products or their published announcements. IBM has not tested those products and cannot confirm the performance, compatibility, or any other claims related to non-IBM products. Questions on the capabilities of non-IBM products should be addressed to the suppliers of those products.

Prices subject to change without notice. Contact your IBM representative or Business Partner for the most current pricing in your geography.

Why Linux on System z - Topics

- **Data Centers**
- **System z Virtualization**
- **System z Engines**
- **System z Security**
- **System z High Availability (HA) and Disaster Recovery (DR)**

System z

Data Centers

Factors in choosing a platform

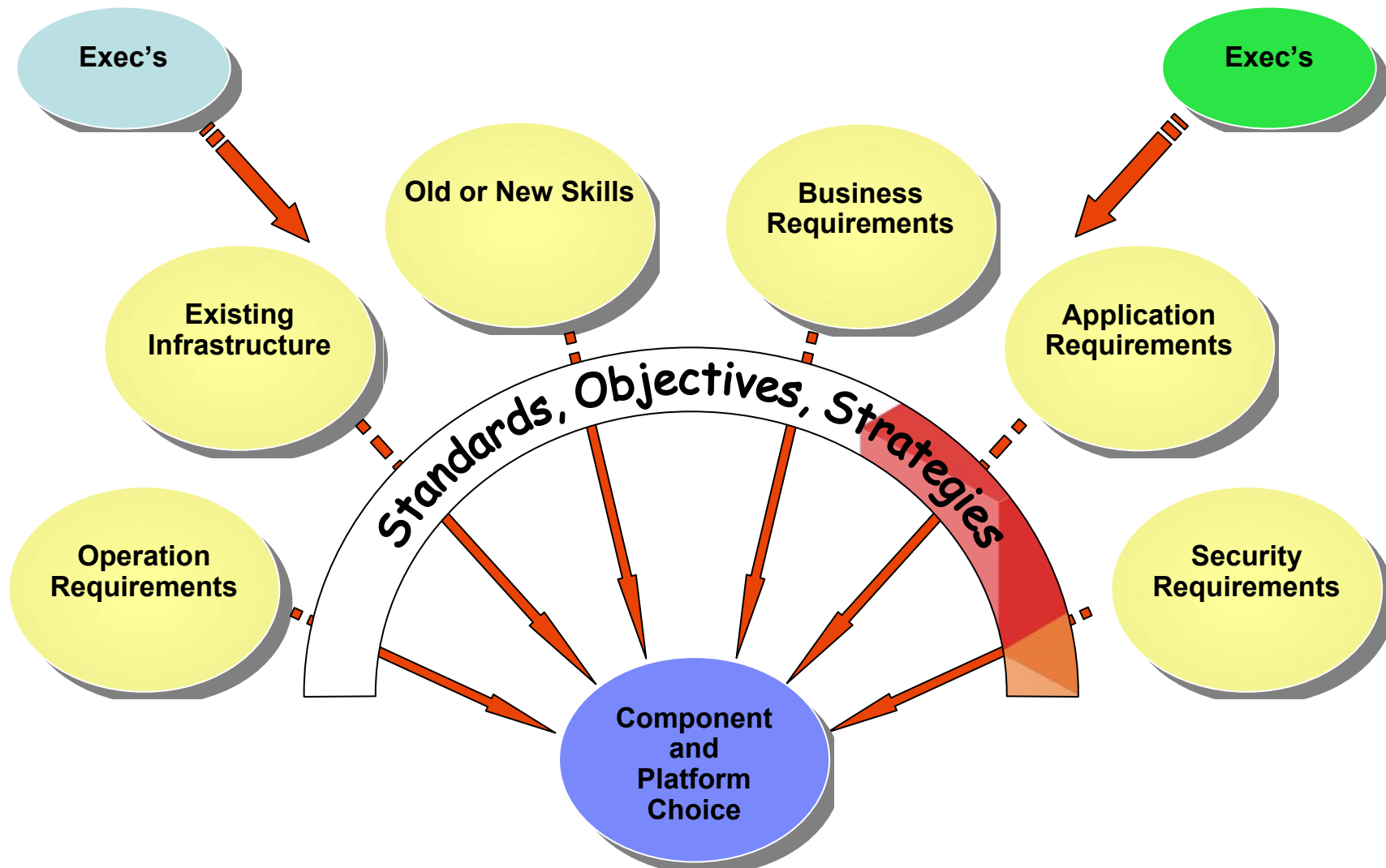

IBM STG Architecture

A design blueprint for building proven IBM enterprise capability

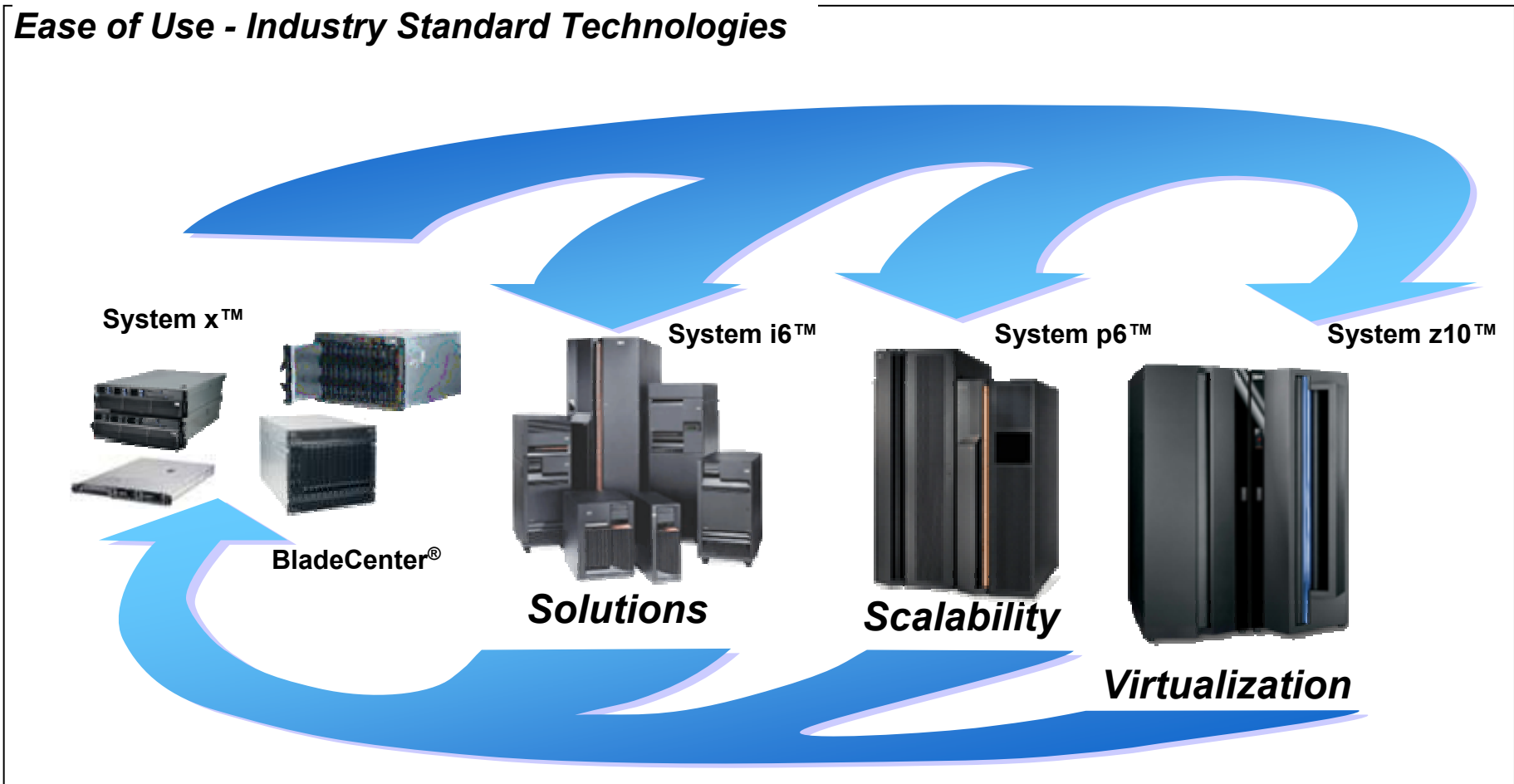

New Enterprise Data Center

- **Evolutionary**
- **Resilient**
- **Efficient**



Multiple forces are driving a transformation of the data center

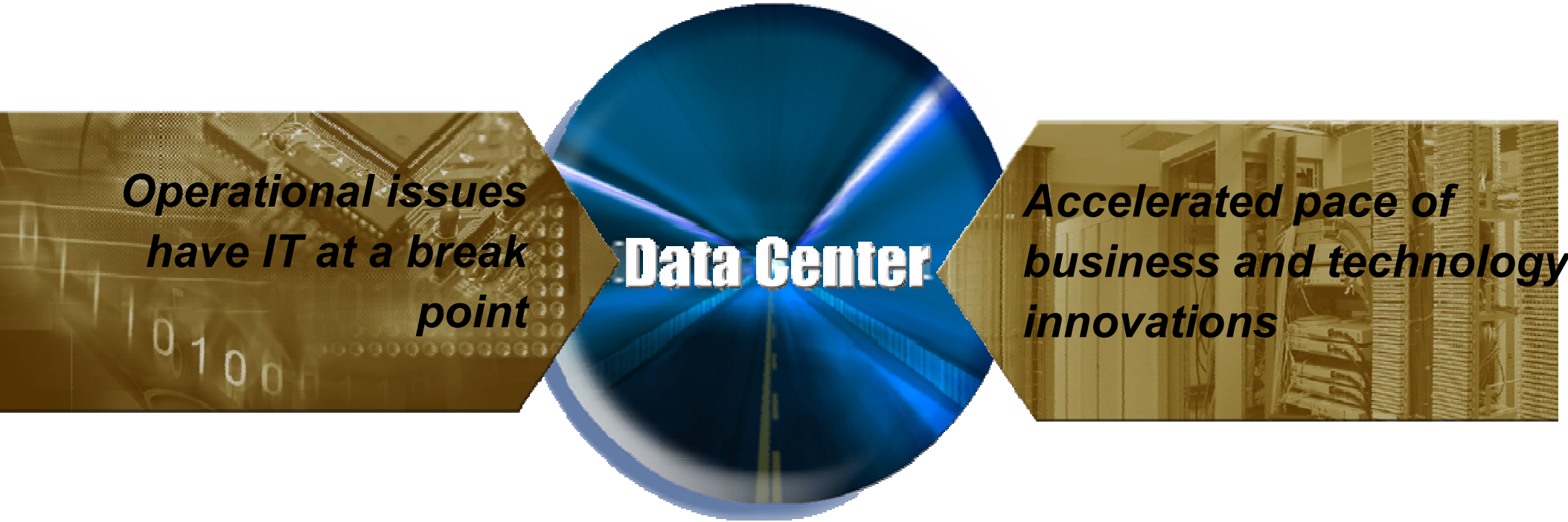

*Operational issues
have IT at a break
point*

Data Center

*Accelerated pace of
business and technology
innovations*

Energy costs 8x

Management costs 4x

70% of IT budget is operational overhead

Globalization

Acquisitions

Green

We really examined the growth of distributed servers in Data Centers

A source of complexity and cost, and a Savings Opportunity

Distributed-systems can proliferate IT costs:

- Cost and complexity (e.g., more physical servers, real network gear)
- Excessive energy usage and heating problems
- Inadequate power and cooling infrastructure
- Data silos and data synchronization
- Linear staffing costs
- Linear per processor software costs
- Frequent outages

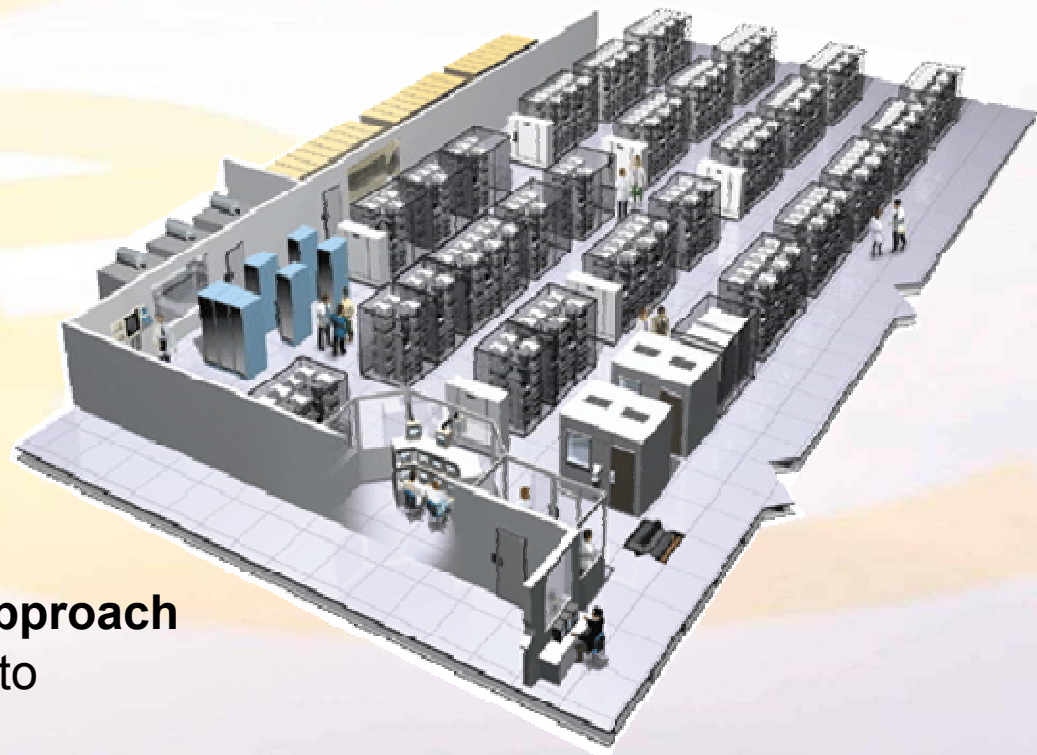

IBM System z10 EC suggests an alternate approach

- ▶ Use fewer, more powerful z10 EC servers to unlock the savings in your Data Centers

LESS IS MORE – Focus on highly efficient use of FEWER servers

Cost of Ownership

- **TCO model should include all relevant costs**
 - ▶ People costs have doubled as a % of total IT cost since 1996
 - ▶ Software costs have grown linearly. Much of it is CPU based.
 - ▶ Energy costs could approach total hardware spend in the next several years
 - ▶ Hardware spend has been flat

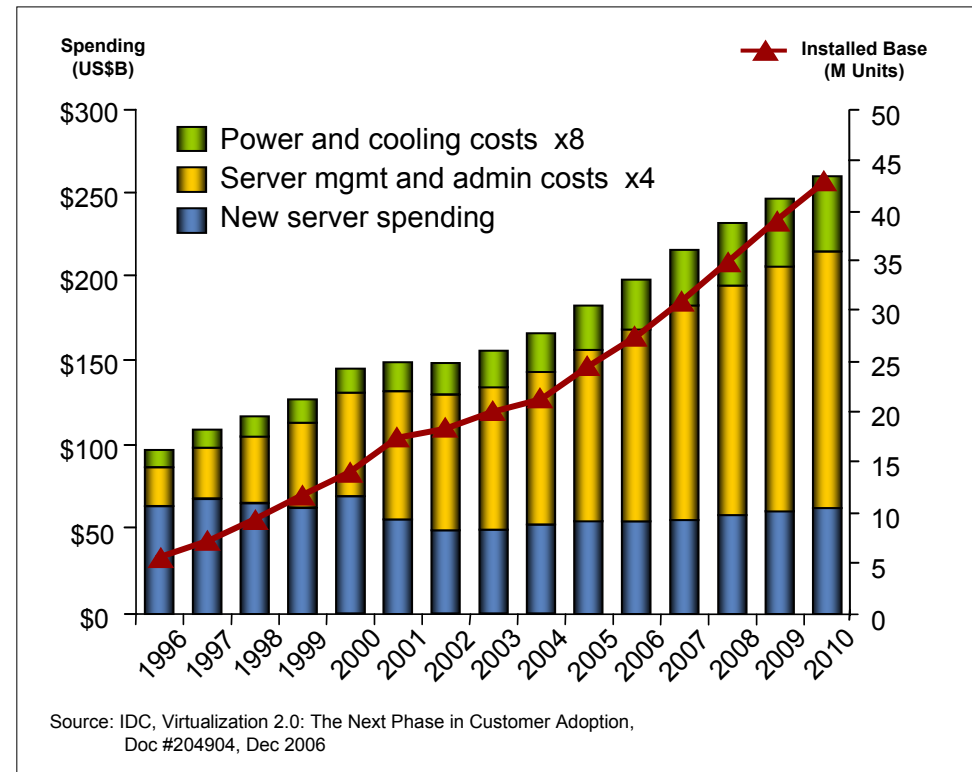

A TCO model that focuses primarily on hardware spend will ignore many of the most significant costs in the datacenter.

When consolidating Linux on low utilization Intel servers, the System z10 Mainframe's ability to provide high utilization may help to reduce both power and facility costs

Power and Space Consumption

System z10 EC

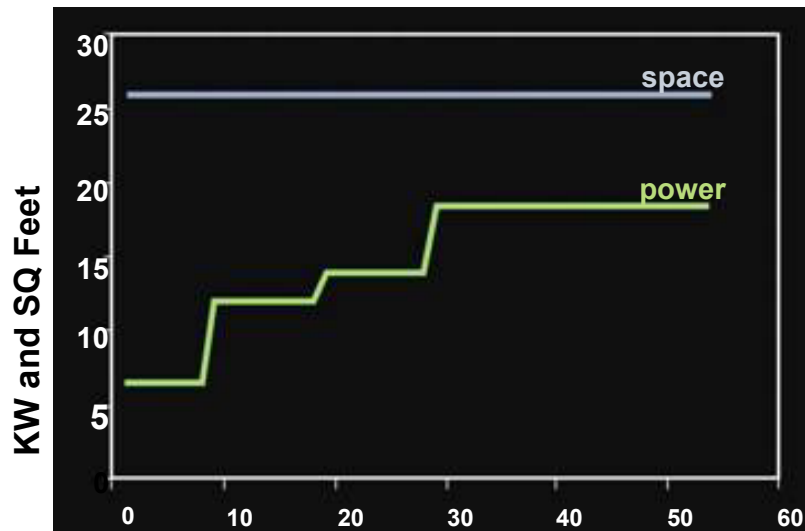

Processors

In a consolidation, the System z10 may provide up to 4 times the same work in the same space and may provide up to 12 times the work for the same power consumption

Linux on Intel

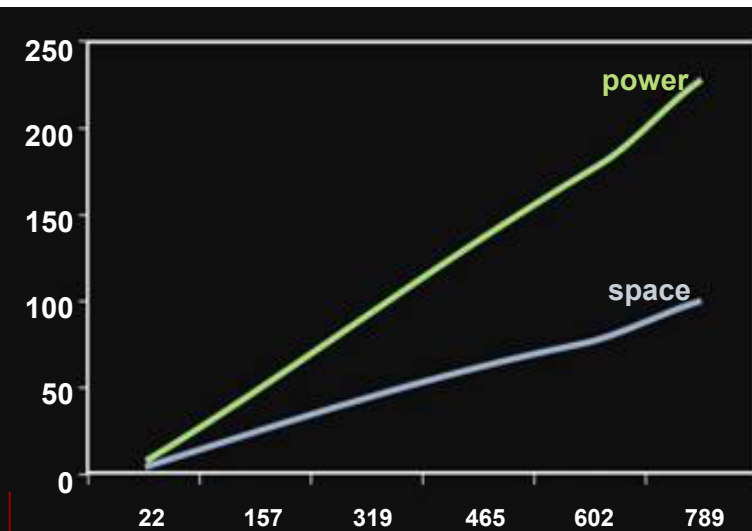

Processors

The Linux on Intel servers selected in this example are functionally eligible servers considered for consolidation to a System z running at low utilization such that the composite utilization is approximately 5%. The utilization rate assumed for System z10 EC is 90%. This is for illustration only, actual power and space reductions, if any, will vary according to the actual servers selected for consolidation.

Linux on System z - Potential Candidates

Medium Peak to Average or Small Workloads (HW / SW Savings)

- Development and test
- Apps with multiple environments that cumulatively have medium peak to average ratios
- Oracle/DB2 databases
- WebSphere
- Tivoli Monitoring
- Sandbox / Training servers

Quality of Service (People / Business Impact)

- System z Hardware RAS
- z/VM - very mature Hypervisor
- Fewer critical Linux patches
- Service bureau virtual hosting
- Lotus Domino
- Infrastructure – LDAP, DNS, TSM, TIM/TAM, FTP
- Critical DR applications

Co-located Applications (with z/OS or other Linux) (Performance / Security / HW)

- CICS / IMS Gateways
- DB2 connect
- Applications with significant z/OS data affinity such as WAS
- SAP Application Servers with z/OS database
- Communication Controller
- MQSeries Queue Manager
- IBI WebFOCUS
- Chatty Linux applications
- Applications that could eliminate security layers between components

Reduce other TCO Factors (People/Other Savings)

- Application environments that can be cloned or replicated (e.g. WebSphere)
- Applications/middleware that can take advantage of shared OS or application binaries
- Speed to market

Linux Strategy (People / Flexibility)

- Significant industry growth in the Linux applications
- IFLs have strong IT industry adoption
- Common OS across platforms reduces administrative costs

Smart, new approaches to business and IT innovation

Leveraging the best of traditional and new approaches

Industrial Strength, Universal Connectivity

Content Browsers Standards

Transactions Systems Mgmt

Web Servers Availability

Security Java

Traditional IT

Cloud Computing

New Enterprise Data Center

Efficient, dynamic and responsive



Fragmented, inefficient islands of computing

Massive Scalability, Rich Diversity

Business Services

Autonomic Management

Sensors

Devices

Real-time Info

Consumer Services

Massive Compute Capacity

Scale-out data center designs

System z

Virtualization



System z Virtualization

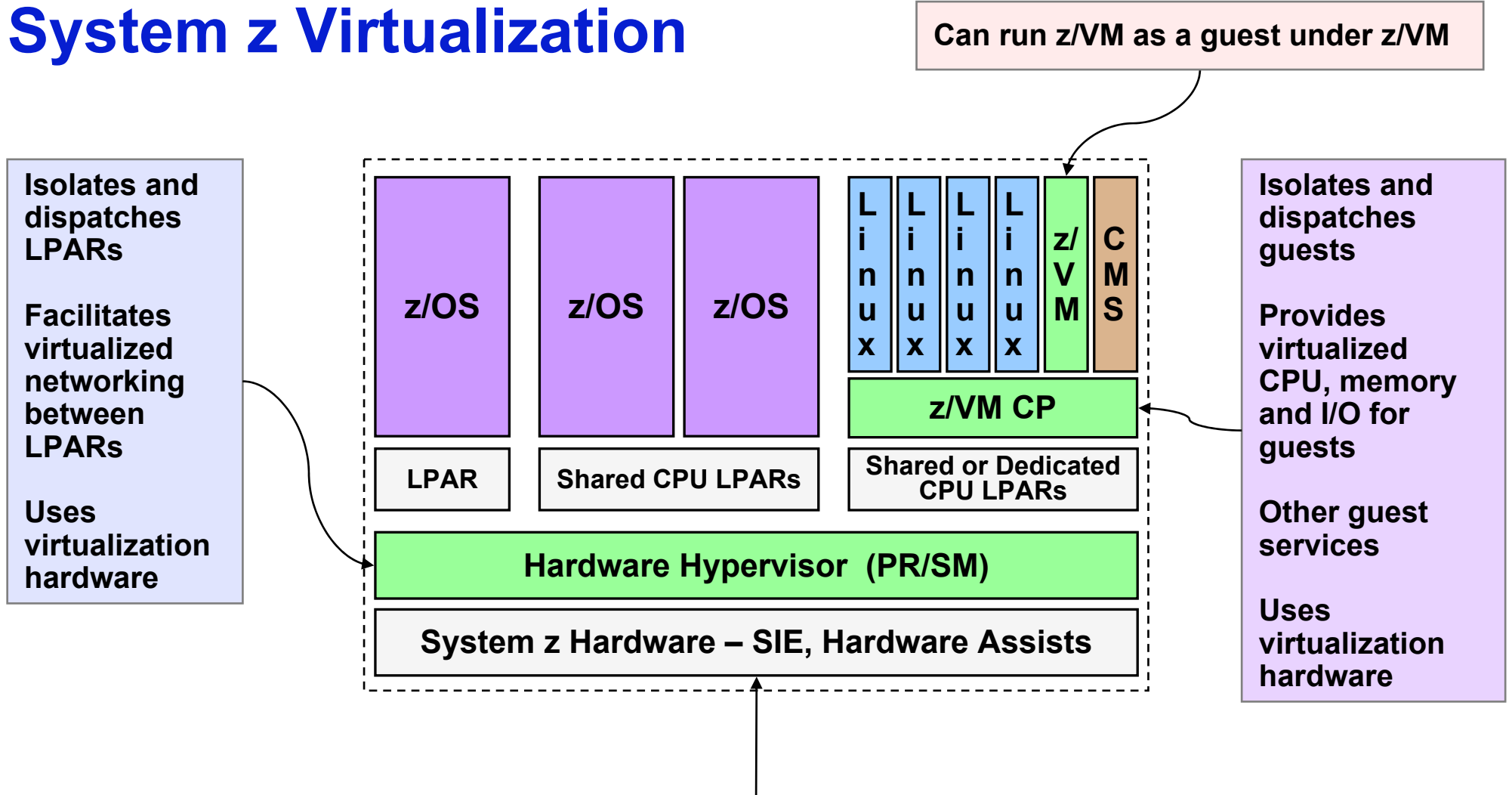

Isolates and dispatches LPARs
 Facilitates virtualized networking between LPARs
 Uses virtualization hardware

Isolates and dispatches guests
 Provides virtualized CPU, memory and I/O for guests
 Other guest services
 Uses virtualization hardware

- The majority of virtualization functions are done directly in hardware
- Hardware - saves and loads guests, does address translation, optimizes wait states and spin locks, provides timer facilities, reflects I/O and timer interrupts directly to guests, provides buffer state management for QDIO, allows for second level Hypervisor (z/VM), and other functions
- Results in low latency, low overhead virtualization capabilities

z/VM Technology: Advanced Disk Support

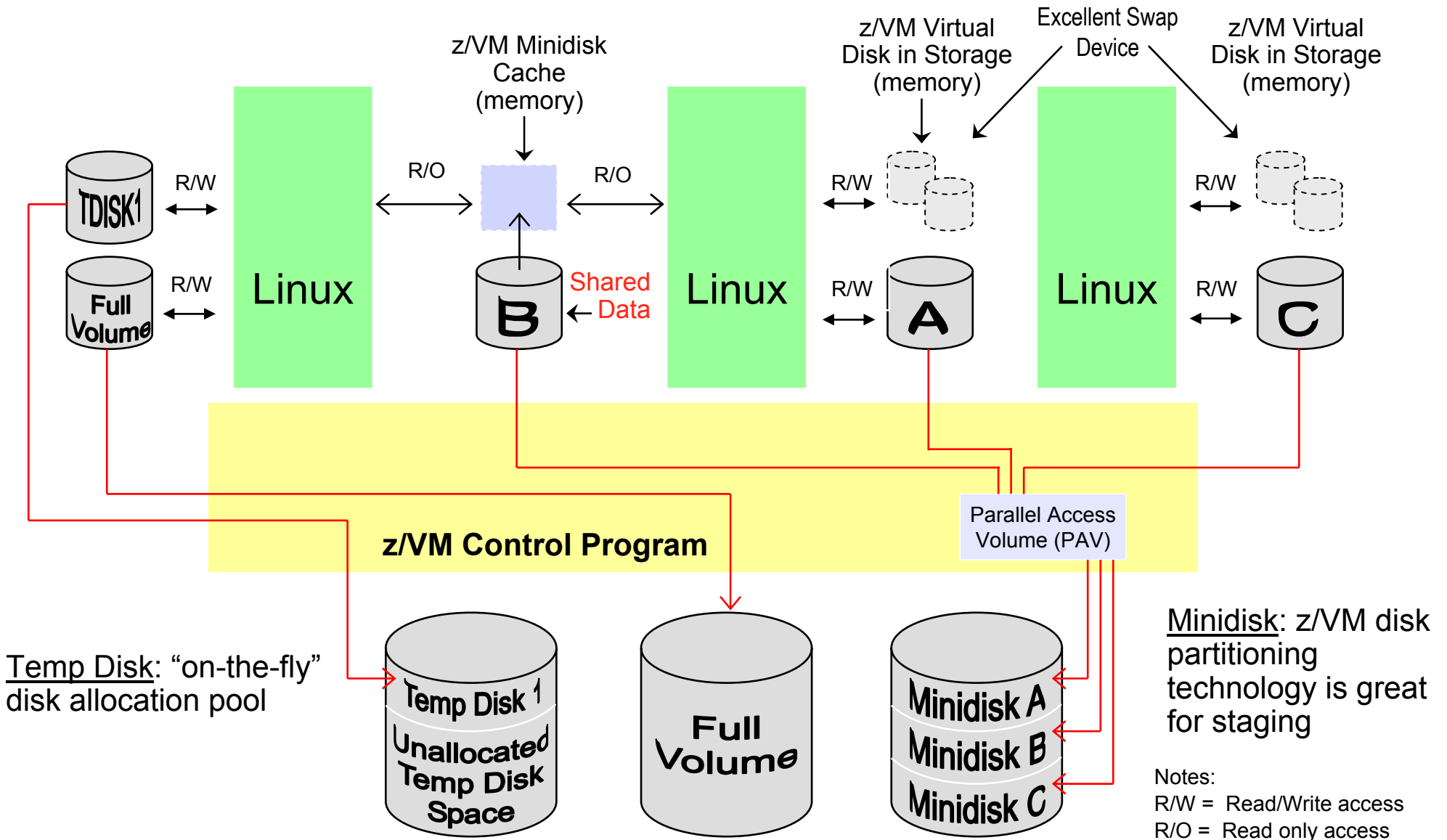

Extreme Linux-on-z/VM Virtualization

Linux Exploitation of z/VM DCSS Support

- Discontiguous Saved Segments (DCSS)
 - Share a single, real memory location among multiple virtual machines
 - Can reduce real memory utilization
- Linux exploitation: shared program executables
 - Program executables are stored in an execute-in-place file system, then loaded into a DCSS
 - DCSS memory locations can reside outside the defined virtual machine configuration
 - Access to file system is at memory speeds; executables are invoked directly out of the file system (no data movement required)
 - Avoids duplication of virtual memory
 - Helps enhance overall system performance and scalability
- **z/VM V5.4 support enhancements:**
 - Segments can reside above 2 GB address line
 - Enables even greater system scalability
 - New addressing limit is 512 GB

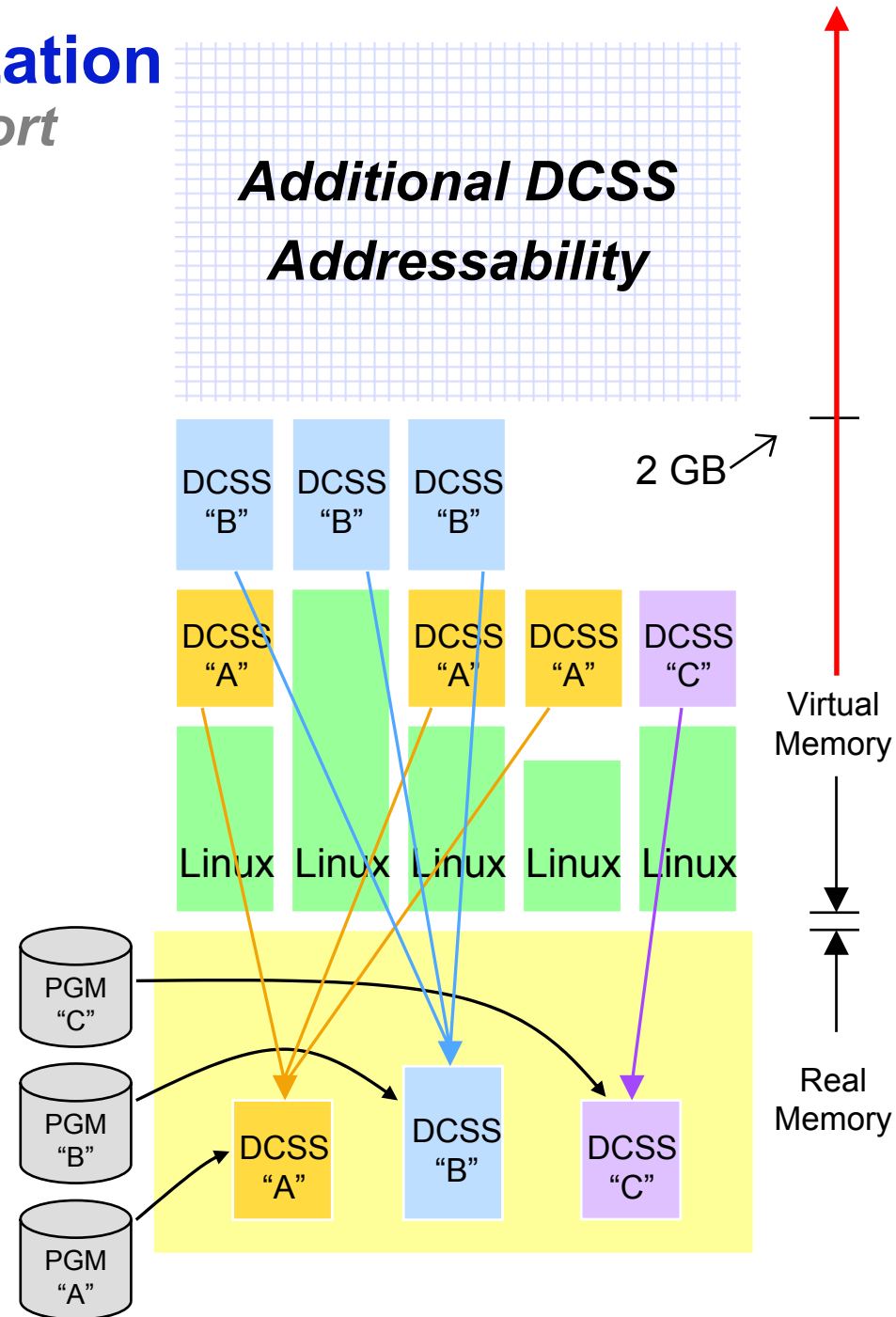

Note: Maximum size of a single DCSS is 2047 MB

Linux and z/VM Technology Exploitation

Cooperative Memory Management (CMM)

■ Problem scenario:

- ▶ Virtual memory utilization exceeds real memory availability
- ▶ z/VM paging operations become excessive
- ▶ Overall performance suffers

■ Solution:

- ▶ Real memory constraint detected by z/VM Virtual Machine Resource Manager
- ▶ Linux images signaled to reduce virtual memory consumption
- ▶ Linux memory pages are released
- ▶ Demand on real memory is reduced
- ▶ Improves performance and throughput

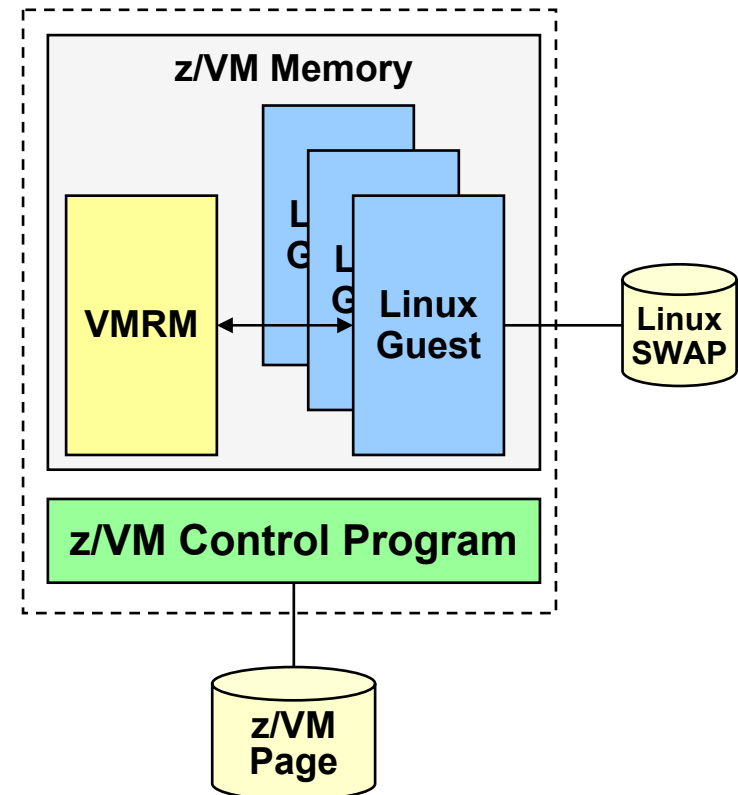

Linux and z/VM Technology Exploitation

■ Collaborative Memory Management Assist

- ▶ Coordination of memory and paging between Linux and z/VM to the level of individual pages
- ▶ z/VM knows when..
 - Linux has released a page of memory
 - Linux is able to just re-read a page from disk
 - Pages are meaningless to Linux

■ Linux knows which pages are resident

- ▶ Supported by System z9 and z/VM V5.3, SLES10, upstream in Linux kernel

■ Host Page-Management Assist

- ▶ Allows the hardware to assign, lock, and unlock page frames without z/VM assistance

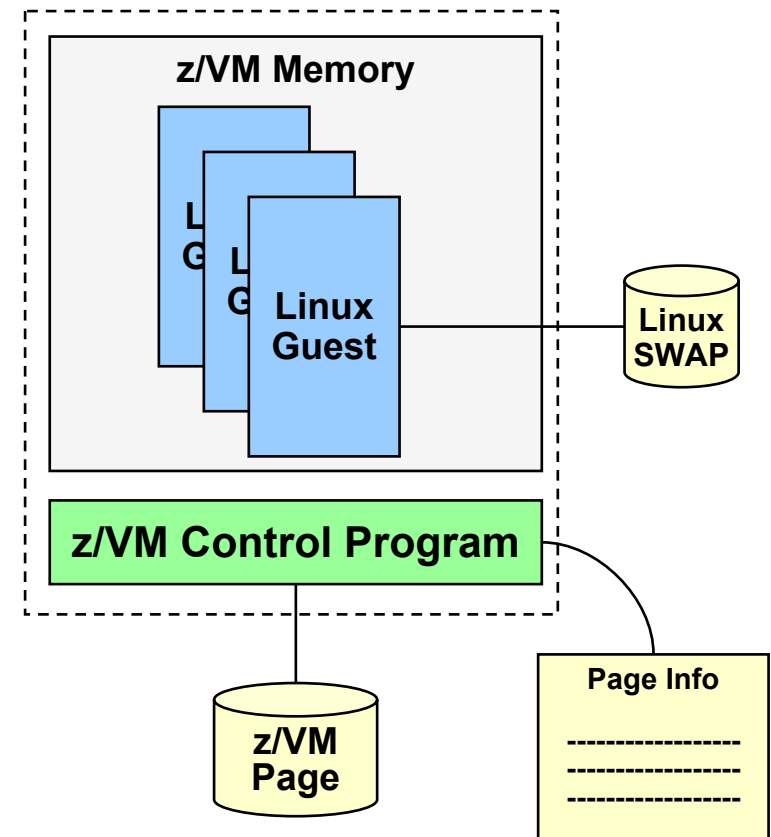

Can help z/VM host more virtual servers in the same amount of memory

z/VM Virtual Switch Support

Layer 3 Compared to Layer 2 Switching

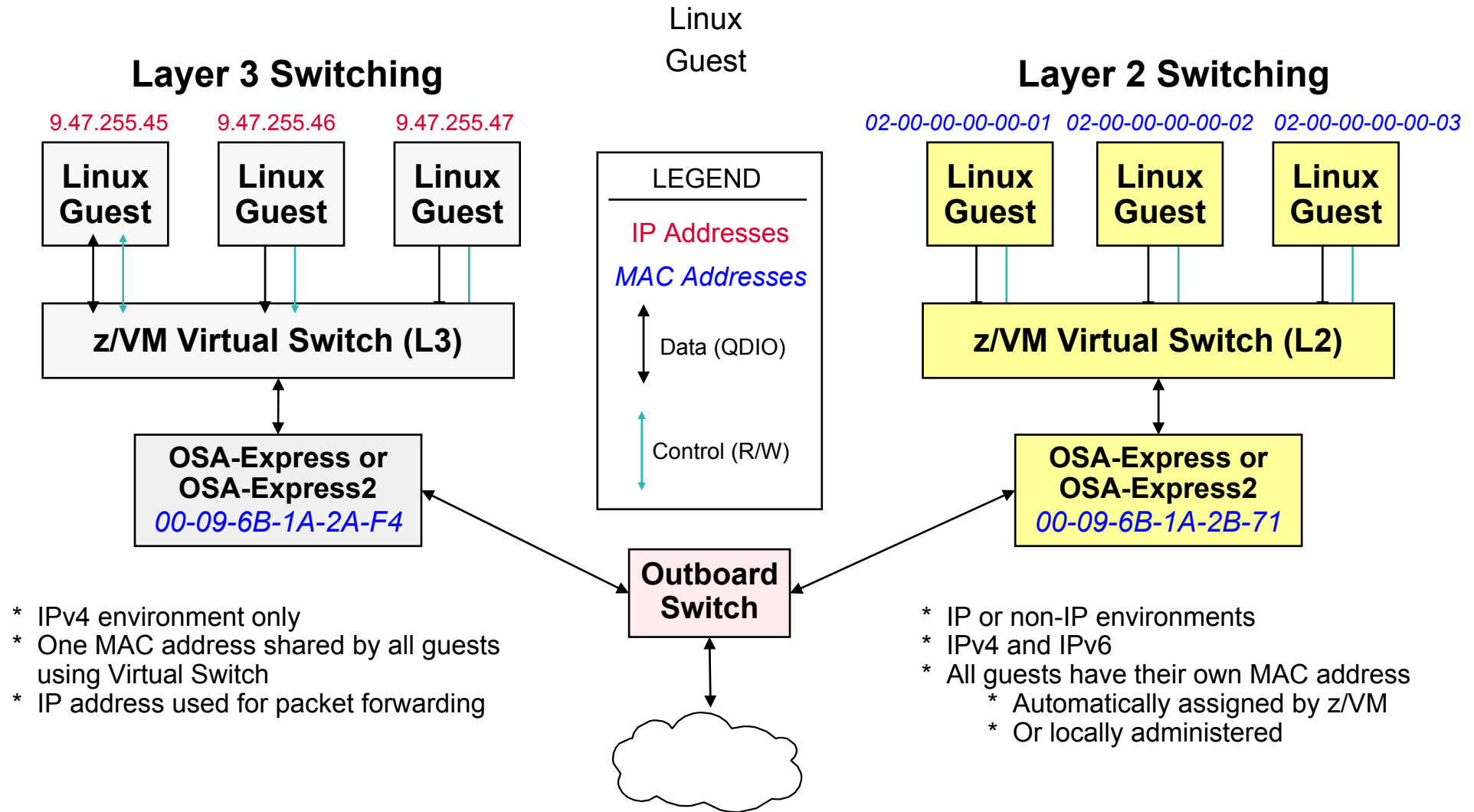

- * IPv4 environment only
- * One MAC address shared by all guests using Virtual Switch
- * IP address used for packet forwarding

- * IP or non-IP environments
- * IPv4 and IPv6
- * All guests have their own MAC address
 - * Automatically assigned by z/VM
 - * Or locally administered

z/VM Virtual Switch Link Aggregation

With z/VM TCP/IP Stack Connectivity Support in z/VM V5.4

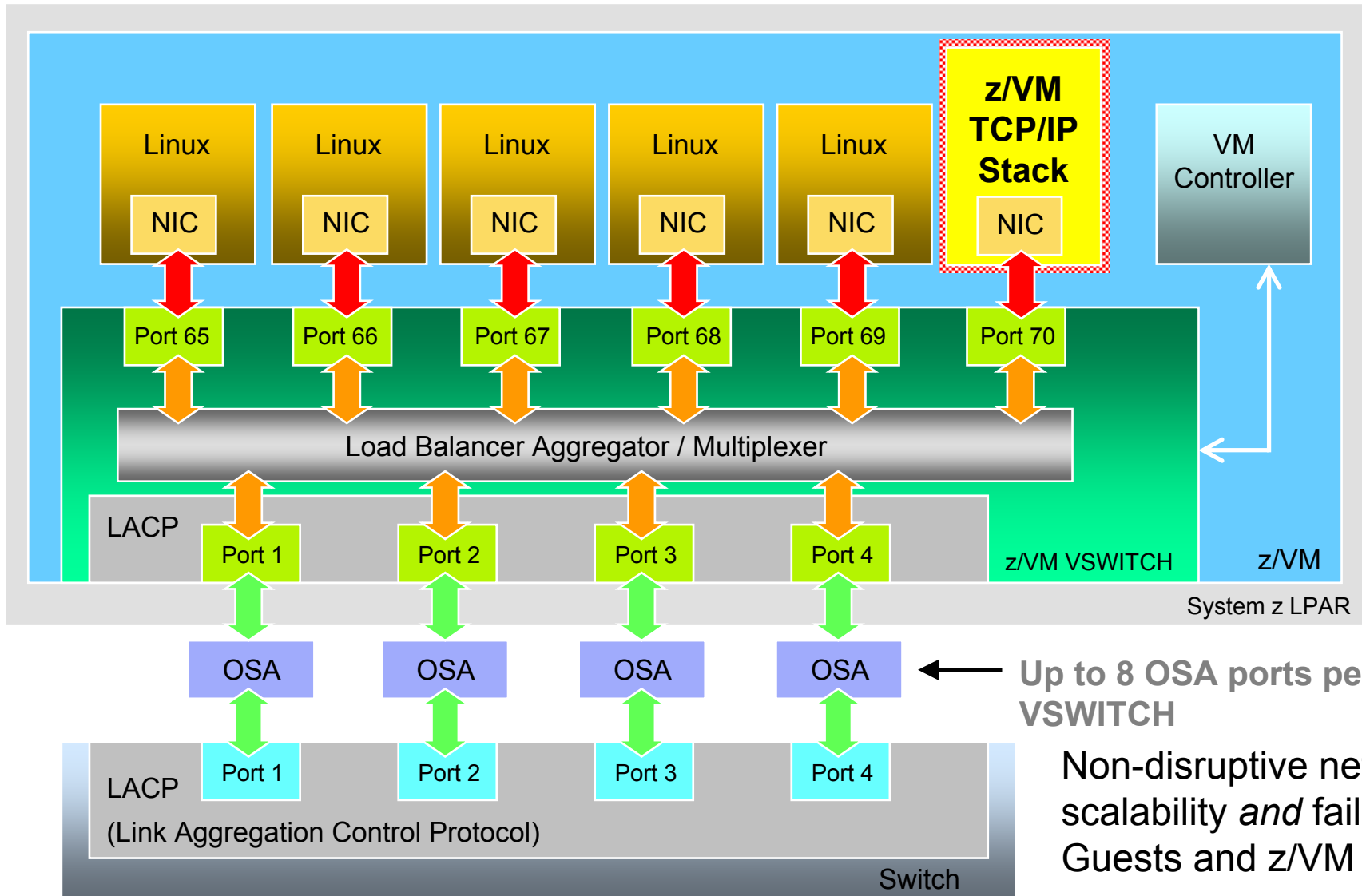

Up to 8 OSA ports per VSWITCH

Non-disruptive networking scalability *and* failover for Guests and z/VM TCP/IP.

Brief History of z/VM

Product	Years	Additional Capacities
CP40	1965-1967	Research projecting on developing a virtual machine CMS, minidisks
CP/67	1967-1972	Time sharing operating system Provide as open source – IBM Type III Library Trap and emulate – problem state/ supervisor state
VM/370	1972-1980	First IBM VM Product RSCS, Virtual Memory, VM under VM, Virtual Storage VM Assist Microcode
VM/SP	1980-1990	REXX, Networking Utilities, Xedit, GCS Shared File Systems, Name Save Systems Discontiguous Saved Segments
VM/HPO	1981-1990	Enhanced performance and memory addressability Preferred Machine Assist
VM/XA	1983-1990	31-bit Addressability Mini-disk cache Start Interpretive Execution Instruction (SIE)
VM/ESA	1990-2000	Queued Direct I/O FICON Channels, CMS Pipelines
z/VM	2001-Present	64-bit Addressability Virtual LANs, HiperSockets, VSWITCH Fibre Channel support

Announcing new releases of:

z/OS, z/VM, and z/VSE

- **“Three operating systems, Many improvements, One conclusion... IBM System z is serious about enterprise data and applications.”**
 - ▶ z/OS Version 1 Release 10
 - ▶ z/VM Version 5 Release 4
 - ▶ z/VSE Version 4 Release 2

- **Operating Systems announcement web site:**
www.ibm.com/systems/z/os/announcement_080508.html

- **System z Web site:**
www.ibm.com/systems/z/

System z

Engines

IBM z10 EC Continues the CMOS Mainframe Heritage

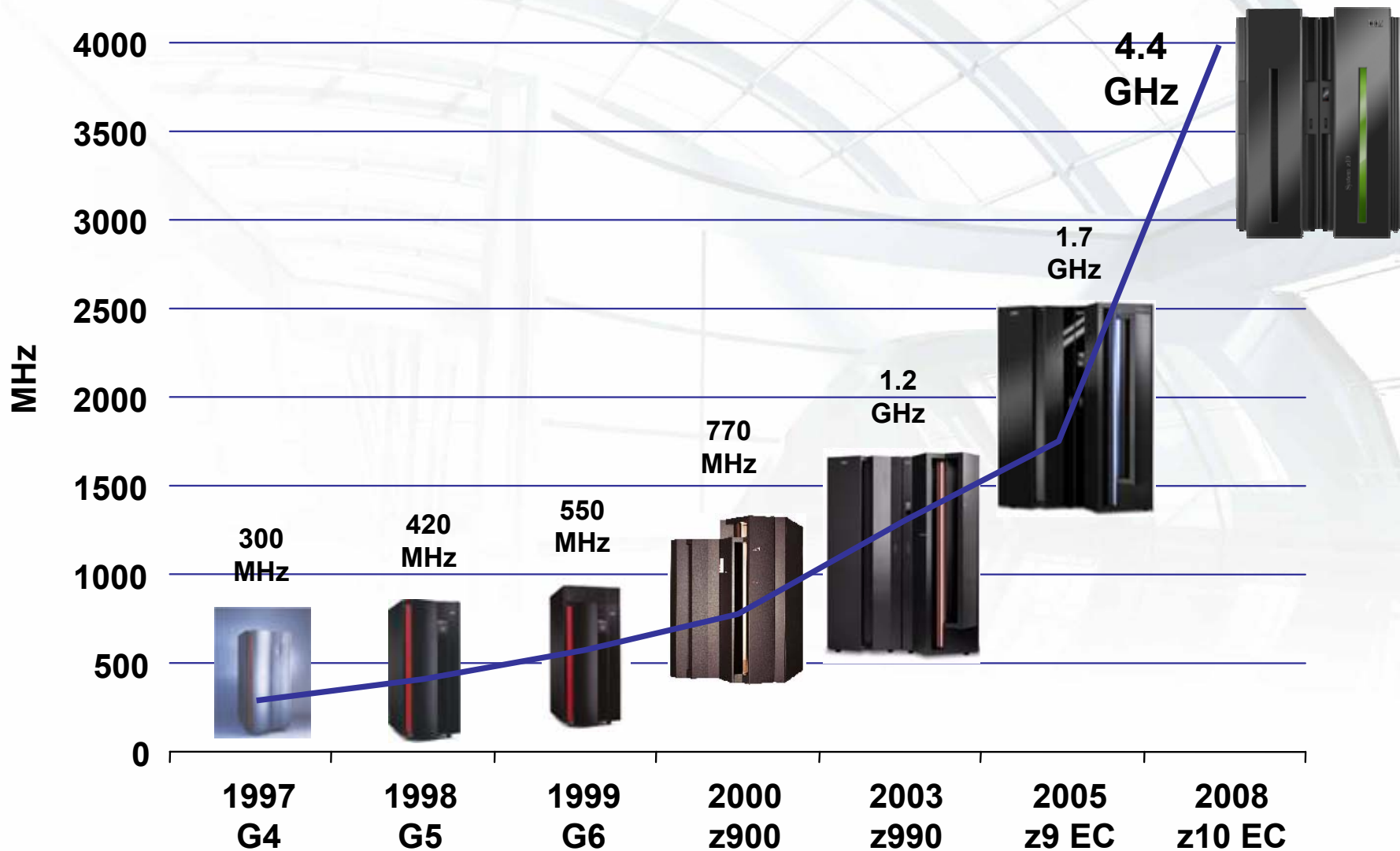

- G4 - 1st full-custom CMOS S/390
- G5 - IEEE-standard BFP; branch target prediction
- G6 - Cu BEOL
- z900 - Full 64-bit z/Architecture
- z990 - Superscalar CISC pipeline
- z9 EC - System level scaling
- z10 EC – Architectural extensions

Evolution of System z Specialty Engines

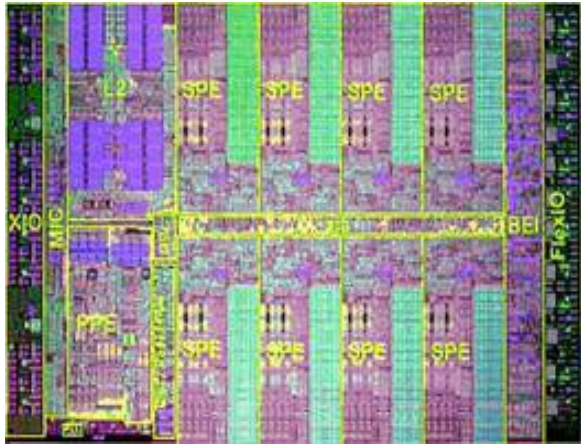

Cell Broadband Engine™

Building on a strong track record of technology innovation with specialty engines – DB Compression, SORT, Encryption, Vector Facility



Integrated Facility for Linux (IFL) 2000



System z Application Assist Processor (zAAP) 2004

- Eligible for zAAP:**
- Java™ execution environment
 - z/OS XML



IBM System z9 Integrated Information Processor (IBM zIIP) 2006

- Eligible for zIIP:**
- DB2 remote access and BI/DW
 - ISVs
 - New! IPSec encryption
 - z/OS XML
 - z/OS Global Mirror*

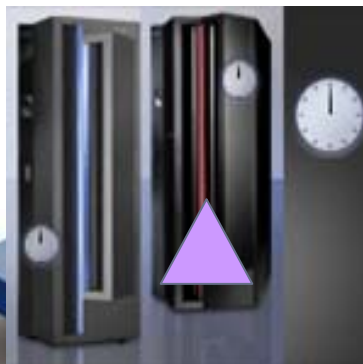

Internal Coupling Facility (ICF) 1997

z/VM 5.4 with the new System z10 EC now allows for any combination of CP, zIIP, zAAP, IFL, and ICF processor-types to reside in the same z/VM LPAR

System z Terminology – Processors

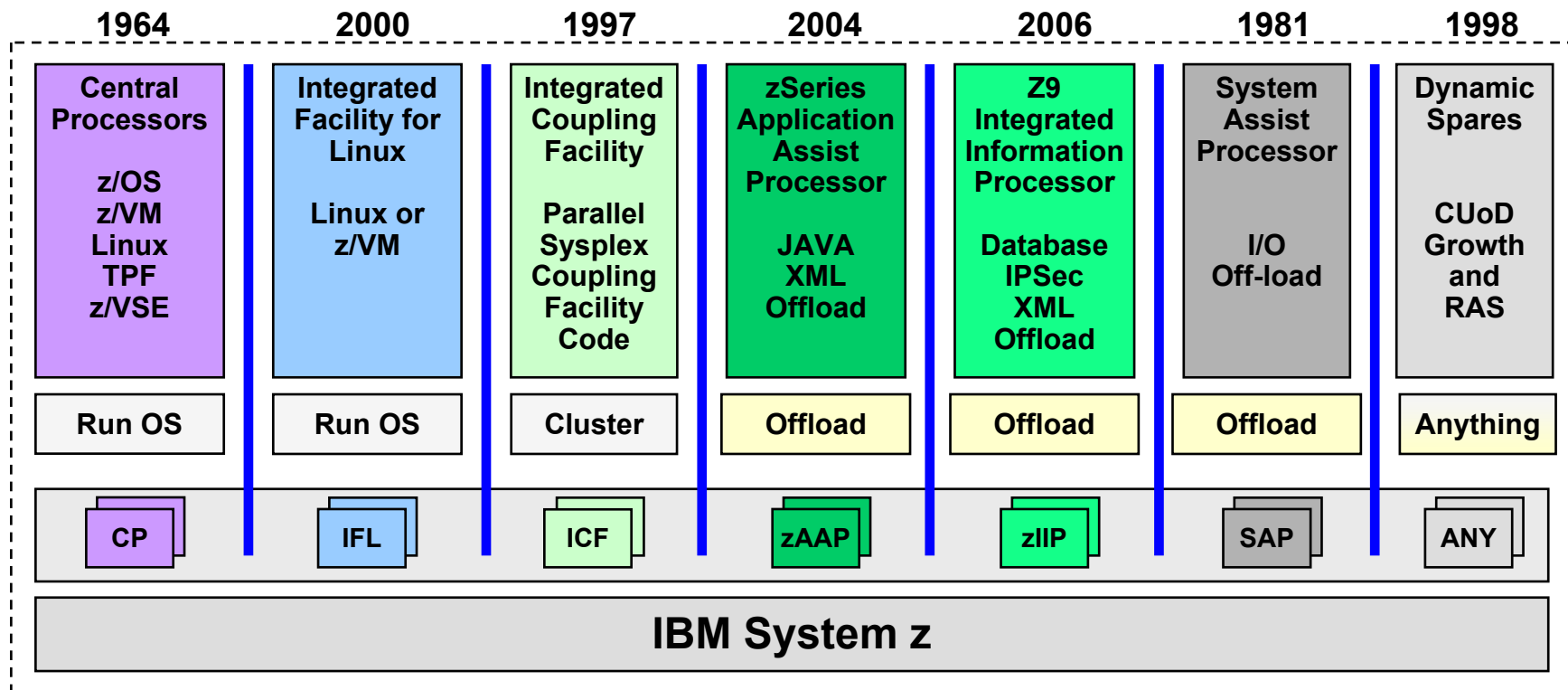

- **Runs operating systems**

- Central Processor (CP)
- Integrated Facility for Linux (IFL)

- **Used for clustering**

- Integrated Coupling Facility (ICF)

- **Central processor offload**

- I/O (SAP), Java (zAAP), DB2 (zIIP)
- Lower hardware and software costs

- **Spares**

- Can dynamically replace any other processor or be turned into any processor for growth

Benefits of zAAP on the Mainframe: Farmers Insurance



FARMERS

Gets you back where you belong.®

Farmers Zurich

Farmers online application experiences CICS transaction volumes of up to 45 million per day, supporting approximately 50,000 users

90% of the revenue business is supported by applications running within WAS for z/OS, which also communicates with applications running off-platform

zAAPs reduced the MIPS on a key application from 1200 MIPS to 700 MIPS (42%)

“Experiences tell us that zSeries is a must, because that is the only platform that can help us deliver all of these qualities. Quality is really, really important, because our customers are dependent upon the availability of these applications and the platform.”

**- Claudia Ku,
Dir of Tech Services**

Svenska Handelsbanken looks to zIIP up security

“zIIP Assisted IPsec provides us with the security our clients demand at an attractive cost to the business”

“Protecting our critical business data and applications is paramount to our business and our clients, so securing our communications from our core mainframe applications to our international offices is a critical element of our overall security policies.

We have successfully tested the integrated IPsec support in z/OS which enables end-to-end encryption from the mainframe all the way to the end device and plan to put into production soon. With the announcement of the zIIP Assisted IPsec, this solution delivers greater value to our business because of the improved price / performance provided by the zIIP specialty engine.”

Ingemar Gustafson,
Manager of zSeries Networking
Svenska Handelsbanken



Svenska Handelsbanken has worked with IBM for many years. The IBM mainframe is a key element of our infrastructure, hosting our critical applications and data. Our mainframe connections were historically secured end-to-end with proprietary SNA connections. As we moved to an all Internet environment, we have implemented end-to-end encryption with IPsec on z/OS for our most secure connections.

The announcement of zIIP Assisted IPsec will improve the economics of this solution as much of the IPsec work can be directed to the lower cost zIIP engines. This will enable our company to expand our use of IPsec-communications directly from our mainframe to our internal servers and to other financial institutions. The ability to use the zIIP engines for much of the IPsec encryption and decryption is a most welcomed enhancement to the overall security solution provided on IBM System z.

Nationwide partners with IBM to improve financial squeeze

■ Business Challenge

- ▶ Pressure on IT growth was forcing them to prioritize IT investments. What started as consolidation project, created unexpected energy savings bonus

■ Solution

- ▶ Use z/VM virtualization to significantly consolidate servers

■ Benefits

- ▶ Expect to save \$16M over the next 3 years
- ▶ Initial phase: 250 Prod / Test / Dev → 6 IFLs
- ▶ Lower power and floor space by 80% over alternatives
- ▶ Lower middleware costs (DB2, WebSphere, Oracle)
- ▶ 50% reduction in monthly charges for Web infrastructure
- ▶ Dramatically improved server provisioning speed
- ▶ Able to add workloads with out additional FTEs



Nationwide[®]
On Your Side[™]

"Nationwide's Linux on System z project is currently estimated to save **\$16 million dollars** over the next three years, not including floor space.

We also were able to provide a reduction in server cost of more than 50 percent to our customers. The Linux on System z system saved significant data center floor space and power consumption."

Steve Womer, Senior IT Architect for
Nationwide in Columbus, OH.

IBM Consolidation Announcement Highlights

■ IBM Consolidation Effort

- ▶ 3900 servers to 15 - z10 mainframes
- ▶ 80% savings in annual energy usage
- ▶ 85% savings in total floor space
- ▶ Labor: 54% reduction
- ▶ Software: 36% reduction
- ▶ Improved availability and DR



Think what we could do for you

IBM'S PROJECT BIG GREEN SPURS GLOBAL SHIFT TO LINUX ON MAINFRAME



Plan to shrink 3,900 computer servers to about 30 mainframes targets 80 percent energy reduction over five years

Optimized environment to increase business flexibility

ARMONK, NY, August 1, 2007 – In one of the most significant transformations of its worldwide data centers in a generation, IBM (NYSE: IBM) today announced that it will consolidate about 3,900 computer servers onto about 30 System z mainframes running the Linux operating system. The company anticipates that the new server environment will consume approximately 80 percent less energy than the current set up and expects significant savings over five years in energy, software and system support costs.

At the same time, the transformation will make IBM's IT infrastructure more flexible to evolving business needs. The initiative is part of Project Big Green, a broad commitment that IBM announced in May to sharply reduce data center energy consumption for IBM and its clients.

System z

Security

What is z/VM System Security?

- **Knowing who is accessing the system or its resources**
- **Ensuring a user only has access to system resources specifically permitted**
- **Knowing who is accessing (or failing to access) what resources**
- **Security is only meaningful in the presence of system integrity**
 - Integrity prevents bypass of security controls
 - Audit trail confirms conformance

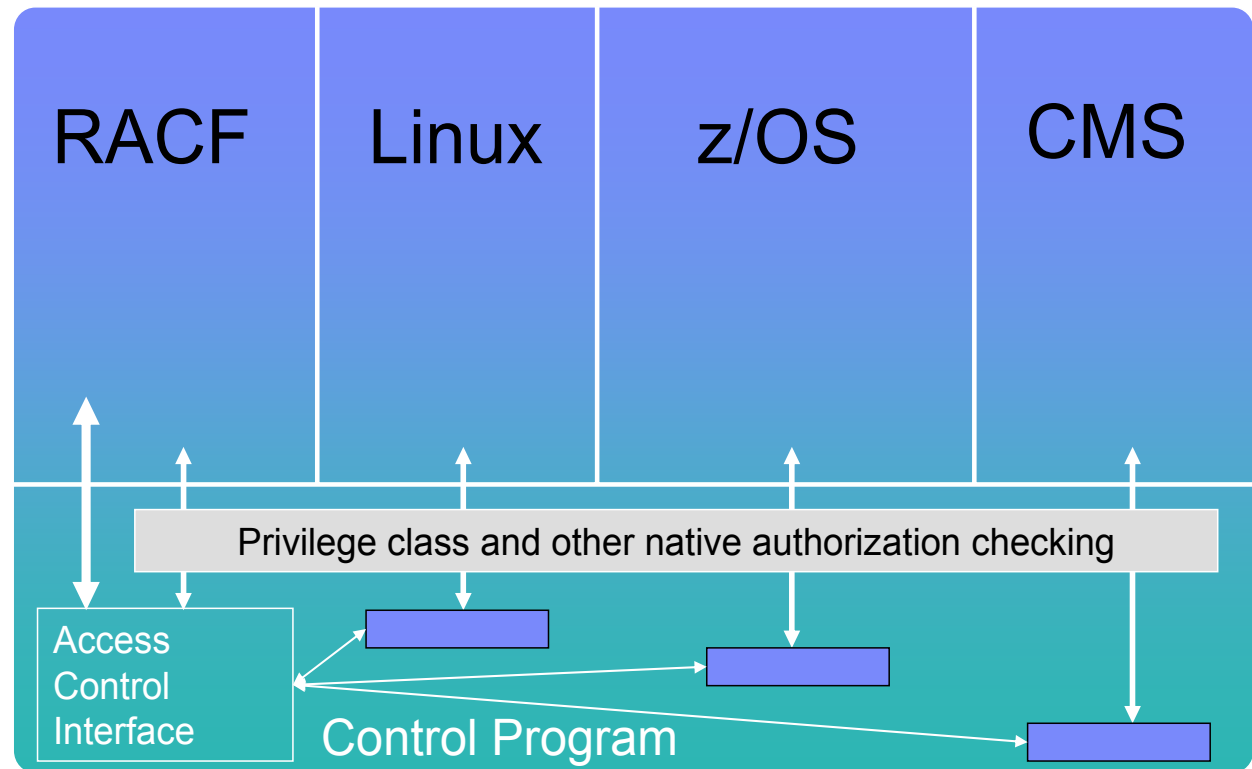

Learn more: "z/VM Security and Integrity" – ibm.com/servers/eserver/zseries/library/techpapers/pdf/gm130145.pdf

The Mainframe Delivers Great Security at Every Level

Crypto Cards



Tape encryption



TS1120

Key management



Multilevel security

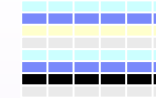

System z SMF

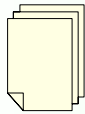

Consul Insight



Consul System z Tools



DB2 Audit Management Expert



Compliance and Audit

Data Privacy



Extended Enterprise

Tivoli Identity Manager



Tivoli Federated Identity Mgr



Platform Infrastructure

Common Criteria Ratings



Support for standards

PKI services



Supports VPNs etc

RACF



Provides audit, authorization, authentication and access

Communications Server



Network intrusion detection

Built in Secured System z Processing Reduces Risk

■ Workload Isolation

- ▶ Each user runs in a separate address space
- ▶ Supervisor state & system programs separated
- ▶ LPAR separation ensures processing integrity
- ▶ Storage Protection controls access to protected areas of storage
- ▶ HiperSockets communication secures network communications at memory speed

■ Encryption

- ▶ Support for encryption in middleware
- ▶ Tape Encryption
- ▶ Key serving
- ▶ System z cryptographic capabilities

■ System Integrity Statement

- ▶ For both z/OS and z/VM
- ▶ Common Criteria

■ Scalability

- ▶ Encryption offload enabled by zIIP
- ▶ High performance solution

Allows customers to place multiple workloads on single z/OS & Linux Images.

Helps prevent malware, viruses and worms from disrupting systems operations.

z/VM Security Examples

■ Privilege Class

- ▶ A - System operator
- ▶ B - Real device management
- ▶ C - System programmer
- ▶ D - Spooling operator
- ▶ E - Systems analyst
- ▶ F - Service representative (CE)
- ▶ G - General user
- ▶ H - Reserved for IBM
- ▶ Customer can use I-Z and 1-6

■ I/O Protection

- ▶ Access to real devices is controlled by the system administrator
- ▶ I/O commands which affect device or subsystem require additional authorization
- ▶ Virtual Switch – restricted use
- ▶ Minidisks can be shared or non-shared

■ External Security Manager (RACF)

- ▶ Can audit all privileged commands and limit use to specific individuals
- ▶ Use Access Control List for minidisks instead of minidisk password
- ▶ Secures “the on/off switch”

■ Intrusion Detection

- ▶ Incorrect passwords
- ▶ Network – Certain denial of service attacks are detected and reported on TCP/IP console
- ▶ Journaling - Guest logons and linking to other guest minidisks are detected and recorded

■ Cryptography

- ▶ Supports the use of all installed cryptographic options simultaneously by different guests on a z/VM system

■ z/VM Currently certified at EAL 4+

Note: This security is in addition to security provided by guest operating systems such as Linux.

z/VM Accounting

- **Collect accounting data**
 - ▶ CPU
 - ▶ Memory
 - ▶ Network devices
 - ▶ I/O adapters
 - ▶ Disk space
- **Useful for charge back purposes**
- **Use in-house reporting scripts or commercial packages**

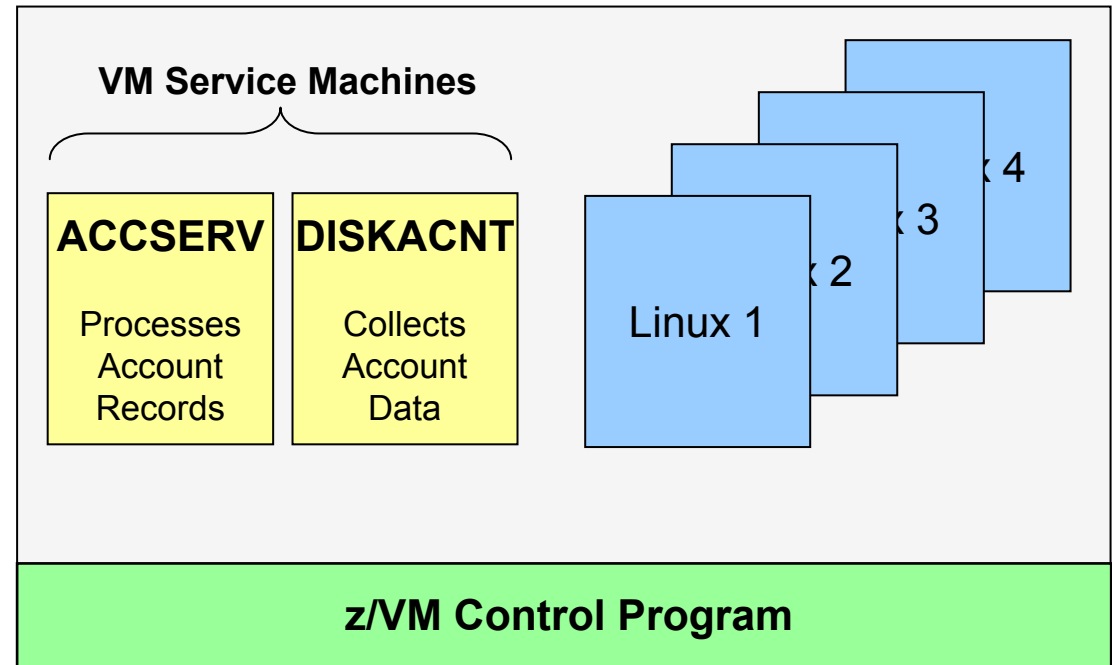

Additional Information: **"Accounting and monitoring for z/VM Linux guest machines"**
Source: <http://www.redbooks.ibm.com/redpapers/pdfs/redp3818.pdf>

Virtualization and Security

Should IT Managers Be Concerned?

Virtualization security risks being overlooked, Gartner warns

Gartner raises warning on virtualization and security.

Companies in a rush to deploy virtualization technologies for server consolidation efforts could wind up overlooking many security issues and exposing themselves to risks, warns research firm Gartner.

“Virtualization, as with any emerging technology, will be the target of new security threats,” said Neil MacDonald, a vice president at Gartner, in a published statement.

– NetworkWorld.com, April 6, 2007

System z

HA and DR



Generic Linux – High Availability

■ Clustering Software (Examples)

- ▶ Tivoli System Automation for Multiplatforms (IBM)
- ▶ Linux HA (open source)
- ▶ Linux Virtual Server (open source)

■ Application Clustering (Examples)

- ▶ Websphere ND
 - Clusters share session data and logs
 - HAManager (new in V6) allows recovery of in-flight 2PC
- ▶ DB2 HADR
 - Provides failover between primary and backup DB2 servers
 - Data is mirrored between servers
 - Fast takeover
- ▶ Oracle RAC
 - Can be run active/active or active/passive
 - Less CPU overhead and faster failover with active/passive configuration

Linux & z/VM High Availability

- **Probably of different scenarios varies greatly**

- ▶ Application is most likely to fail, entire System z box is least likely
- ▶ System z MTBF measured in decades
- ▶ Most hardware and firmware upgrades can be done concurrently

- **Designing HA solution**

- ▶ How much availability is enough?
- ▶ Configure for what you need
- ▶ Can provide multiple Linux and z/VM instances within the same frame

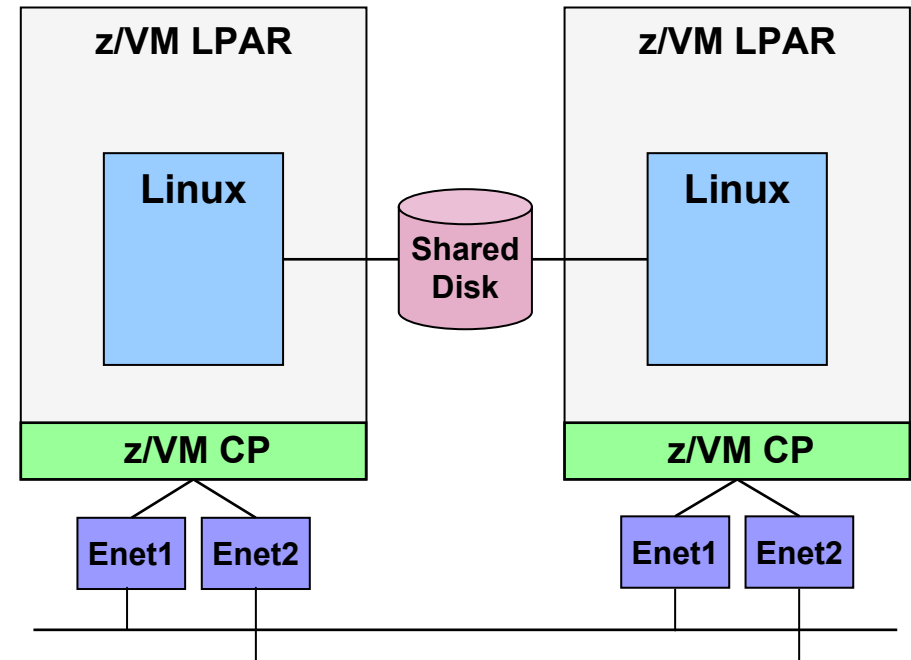

Cross System Extensions (CSE)

- **Guests may access files from any z/VM image in the cluster**
 - ▶ Single sign-on for guests
 - ▶ Maximum 4 nodes
 - ▶ ECKD Storage Devices
 - ▶ DirMaint - manage directories

- **Capability to share**
 - ▶ Minidisks
 - ▶ Replicate spool files

- **Commands may be sent among images in the cluster**
 - ▶ Cross System Messages
 - ▶ Cross System Query

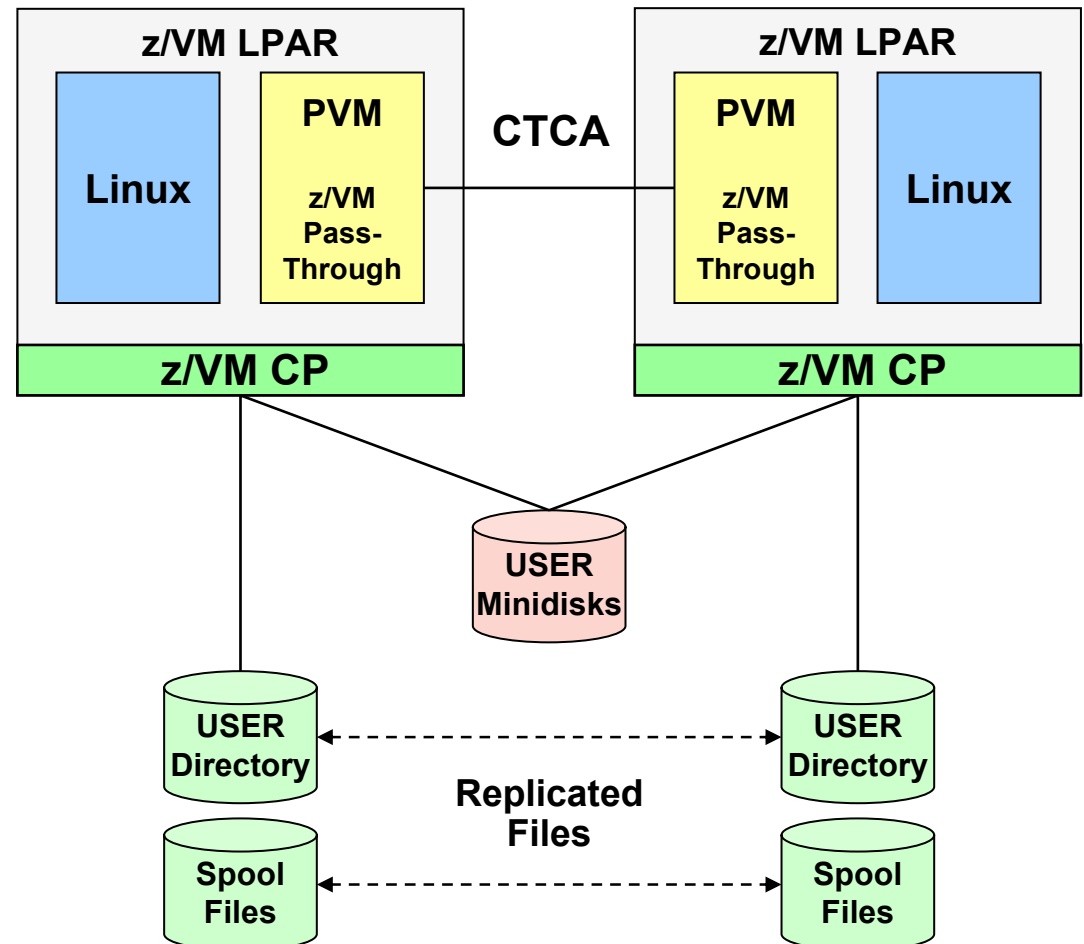

GDPS/PPRC Multiplatform Resiliency for System z

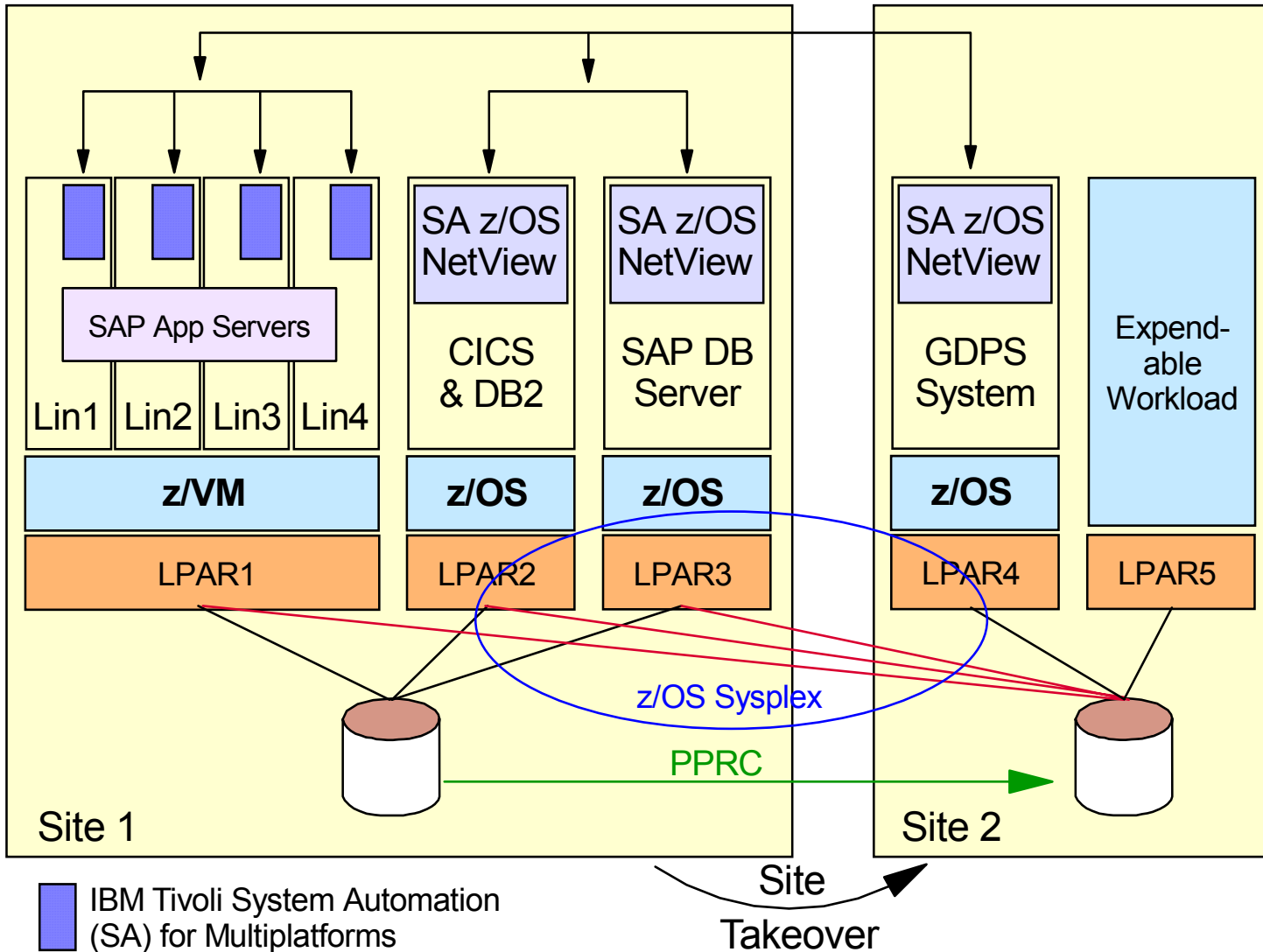

- Designed for customers with distributed applications
- SAP application server running on Linux for System z
- SAP DB server running on z/OS
- Coordinated near-continuous availability and DR solution for z/OS, Linux guests, and z/VM
- Uses z/VM HyperSwap function to switch to secondary disks
- Sysplex support allows for site recovery

z/VM Dynamic Memory Upgrade

New z/VM V5.4 Function Enhances System Availability

- **Users can non-disruptively add memory to a z/VM LPAR**
 - Additional memory can come from: a) unused available memory, b) concurrent memory upgrade, or c) an LPAR that can release memory
 - Memory *cannot* be non-disruptively removed from a z/VM LPAR
- **z/VM virtualizes this hardware support for *guest machines***
 - Currently, only z/OS and z/VM support this capability in a virtual machine environment
- **Complements ability to dynamically add CPU, I/O, and networking resources**

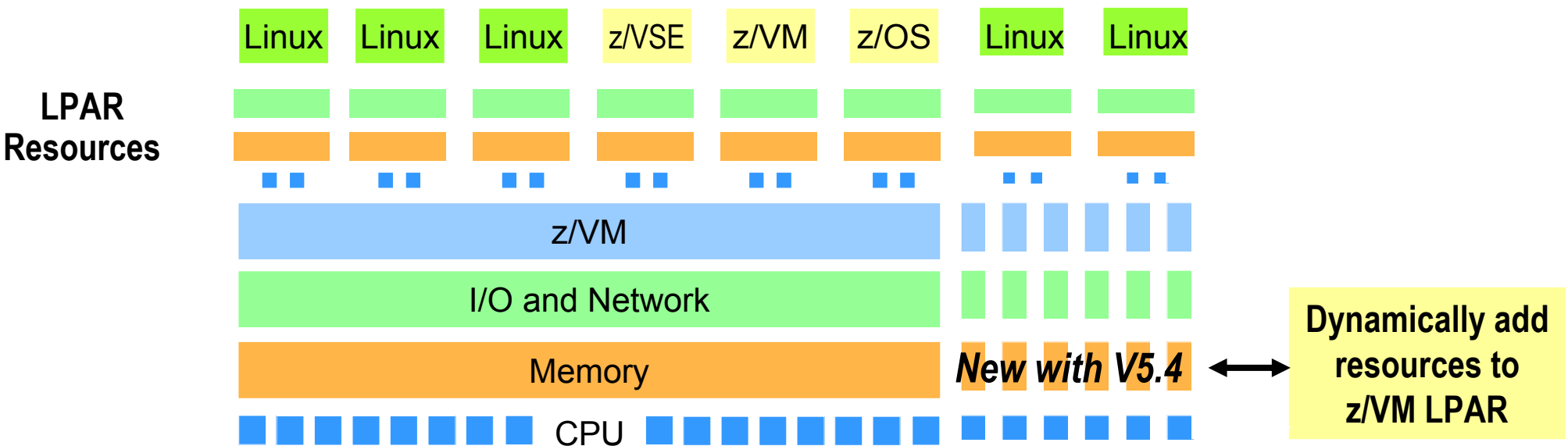

Smart economics: non-disruptively scale your z/VM environment by adding hardware assets that can be shared with every virtual server

Disaster Recovery Options

Recover Point & Recovery Time Objectives	MIPS	Memory	Data	Notes
Low	Cold site Device drivers simplifies	Cold Site	Usually Tape Vaulting	System Z easier than on generic Linux due to device drivers
Moderate	CBU Contract for MIPS	Memory must be available	PPRC to Tape Vaulting	
High	Hot site available	Hot Site Available	PPRC with Hyperswap	Can use VMRM to prioritize workload in active/active configuration

Need MIPS, memory, data (and network) to handle DR. RPO and RTO objectives will dictate possible approaches.

Disaster Recovery – Tape Options

■ Full volume backup

- ▶ Can be done with z/OS, or z/VM
- ▶ Very fast tape drives
- ▶ May need to quiesce systems (not always)
 - Flashcopy can reduce downtime
- ▶ Most useful for major problems
 - DR
 - Entire volume loss
 - Etc.
- ▶ Easily incorporated into existing z/OS backup strategies

■ File by file backup

- ▶ Numerous products, e.g. TSM, Veritas
- ▶ Incremental backup – quick
- ▶ Full restore can be slow and network limited
- ▶ Most useful for “oops” scenario
 - Need to retrieve single file

■ Most companies use both for Linux on Z

- ▶ Different recoveries for different failure scenarios

Evolution of data center energy efficiency



Centralization

- Consolidate many centers into fewer
- Reduce infrastructure complexity
- Improve facilities management
- Reduce staffing requirements
- Improve business resilience (manage fewer things better)
- Improve operational costs

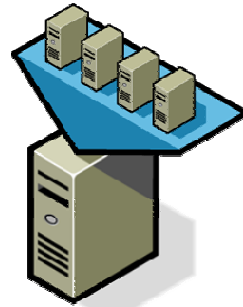

Physical Consolidation

- Consolidate many servers into fewer on physical resource boundaries
- Reduce system management complexity
- Reduce physical footprints

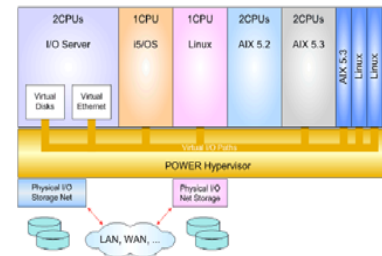

Virtualization

- Remove physical resource boundaries
- Increased hardware utilization
- Allocate less than physical boundary
- Reduce software licensing costs

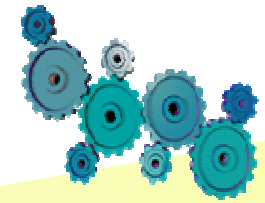

Application Integration

- Migrate many applications into fewer images
- Simplify IT environment
- Reduction of operations resources
- Improve application specific monitoring and tuning

Time for ?

Always time for Follow-up

**Thank You,
Kurt Acker**
Bfishing@us.ibm.com

Want help with System z virtualization strategy planning, server consolidation, and complete data center management solutions:

Your local IBM sales rep has new workload sales specialist ready to help create successful project plans with you today.

System z

Back up charts

Automated Linux Installation

Operating System (OS) Template - Concept

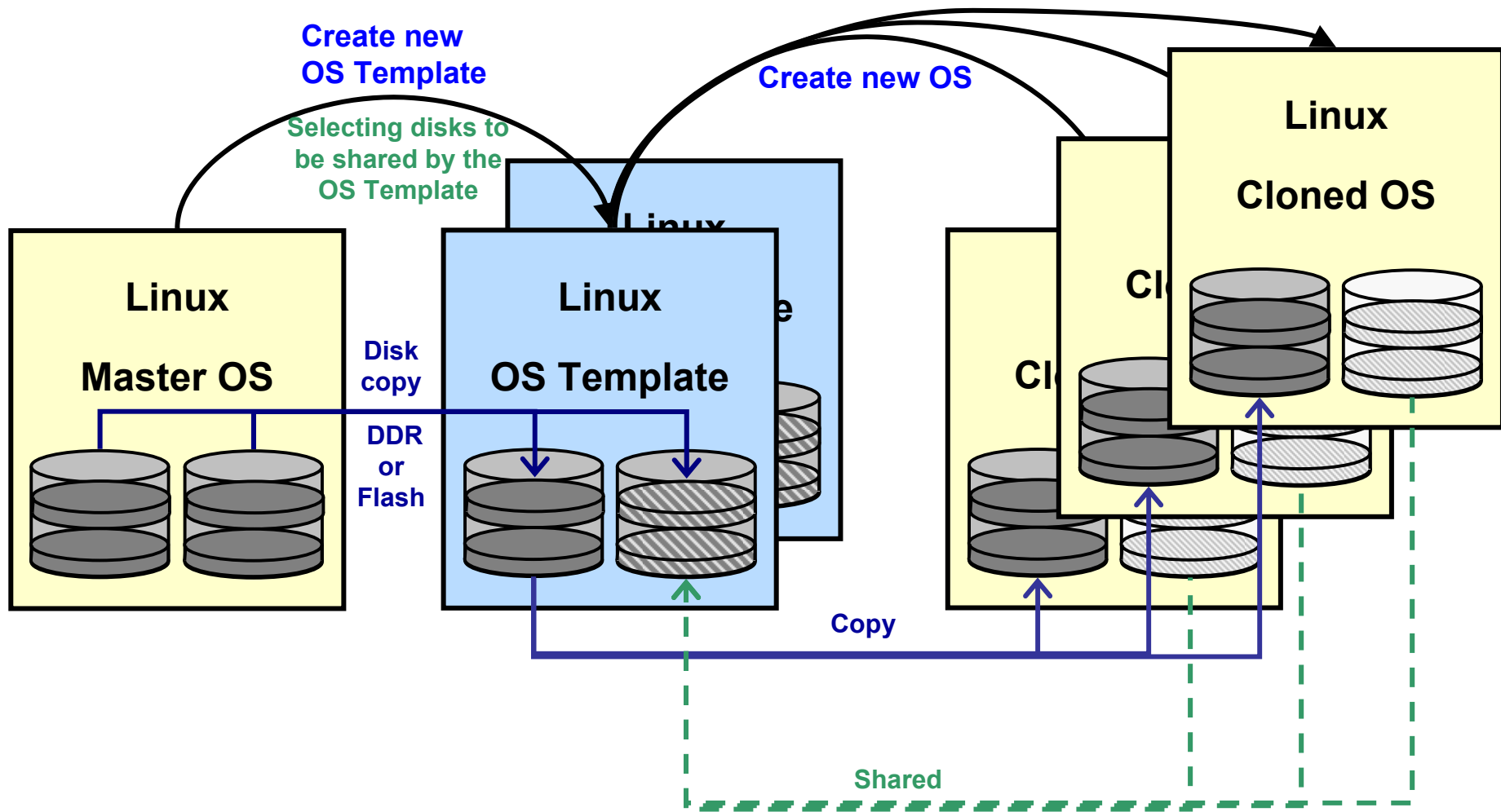

Note: Shared disks are an option and are not required

Cloned WebSphere Systems - Example

- **Clone WebSphere Linux guests**
 - ▶ Rapidly clone WebSphere systems
 - ▶ Can build a system in under 30 seconds
 - ▶ Each with their own cloned Linux image
 - ▶ Customized WAS profile
- **Exploit shared disk**
 - ▶ Single shared WAS binaries

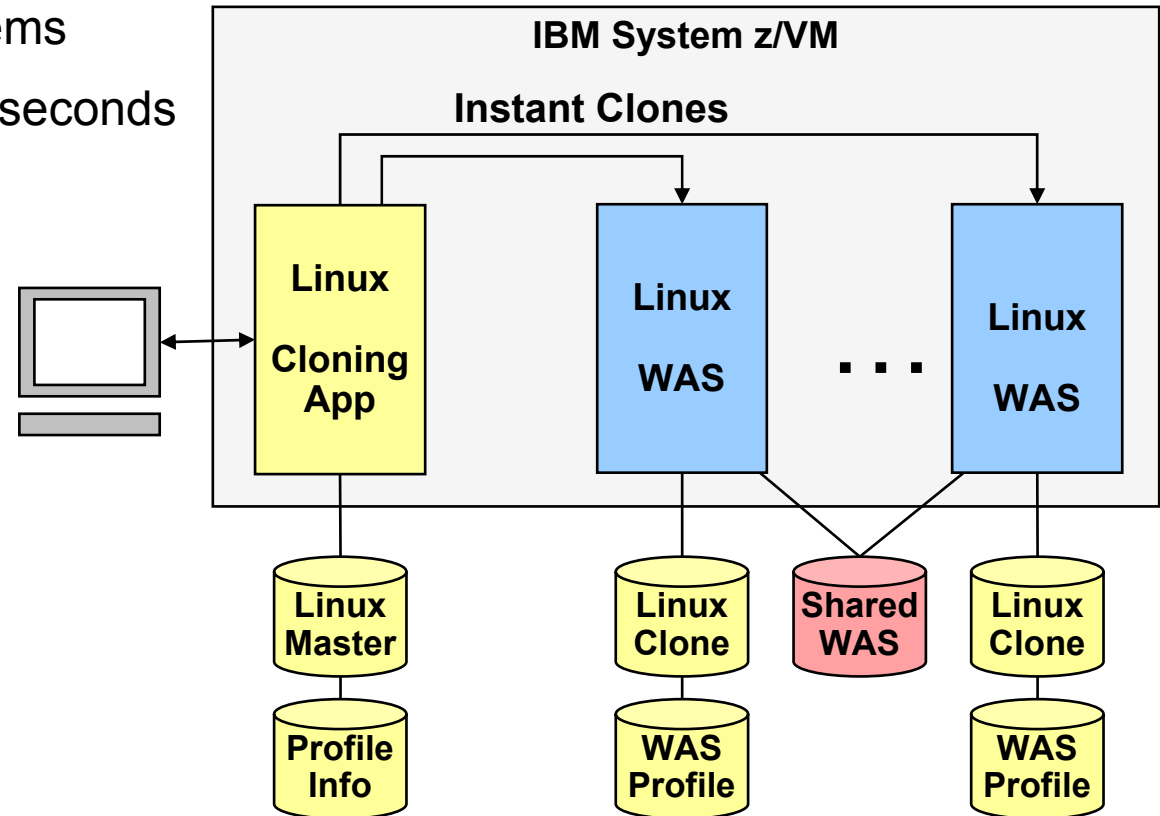

Shared Disk Example - WebSphere Binaries

- **Clone WebSphere Linux guests**
 - ▶ Each with their own cloned Linux filesystem copies
 - ▶ Single shared WAS binaries
- **Can mix/match shared and dedicated disks**
- **Benefit**
 - ▶ Patching done once
 - ▶ Rollout and rollback a matter of updating directory statements and links
 - ▶ No additional software (such as NFS) is required

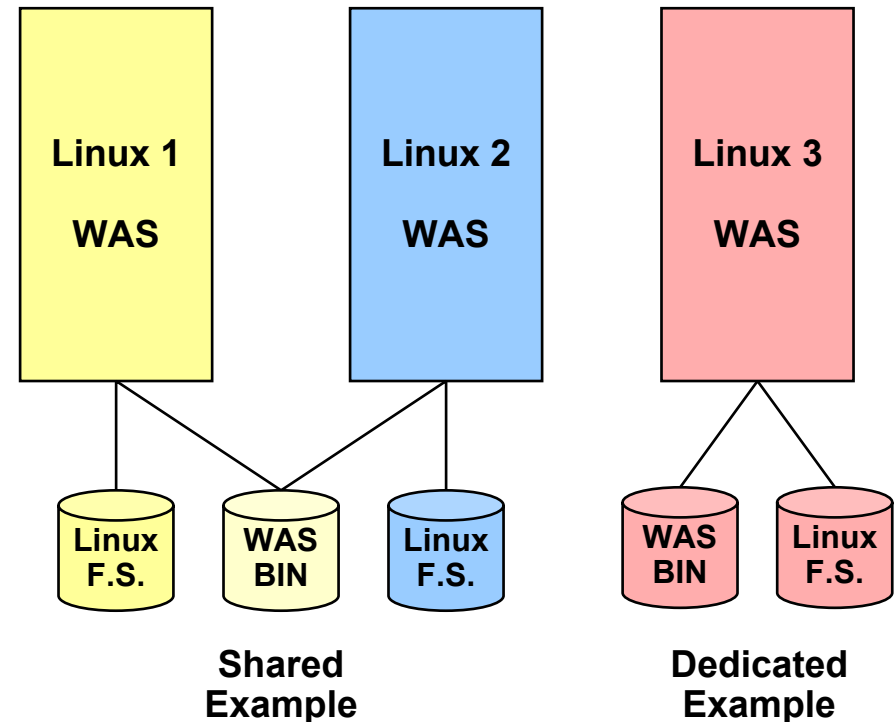

Sample Cloning Scripts

■ Sample Scripts

- ▶ Sample scripts for a simple cloning utility are included in the Virtualization Cookbook Redbook
- ▶ This Redbook can be found at:

<http://www.redbooks.ibm.com/abstracts/sg246695.html>

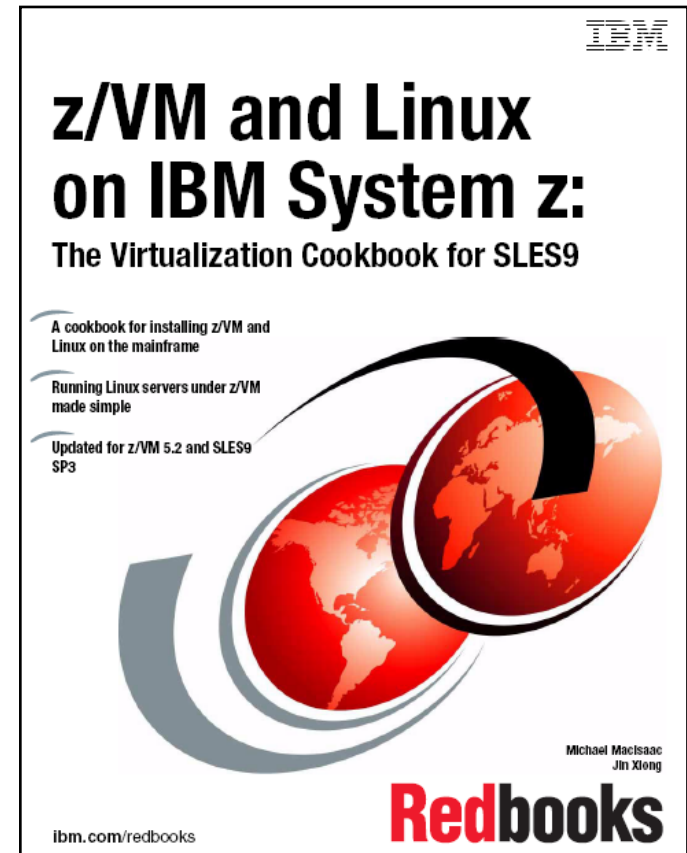

Why the new momentum for the mainframe?



What HP Says . . .

The Facts . . .

“Mainframes are old”

1. z10 = State-of-the-art technology driving mission critical applications with instant response to changing business dynamics.

“Mainframes are proprietary”

2. System z is open (Linux, Java™, WebSphere) and delivers a superior operations model to meet customer governance, risk and compliance management needs.

“Mainframes are expensive”

3. Our client’s experience indicates that consolidation on a z10 can reduce TCO by up to 80%, compared to distributed systems.



“IBM’s z10 is the computer industry’s pinnacle systems platform. Blow-away performance (fast quad-core processors), increased capacity (1.5 times greater than its predecessor), and expanded memory (three times greater than its predecessor) makes this system the absolute best scale-up architecture — bar none — in the computing industry.”

Joe Clabby, Clabby Analytics, February 26, 2008

Myths and Reality

■ Myth

1. Mainframes are expensive
2. Mainframes are slow
3. Mainframes customers are shrinking
4. IBM milks the Mainframe as a cash-cow
5. Putting Linux on a Mainframe is stupid
6. The development of a specialized micro for the mainframe is not sustainable

■ New Reality

1. Once you get past the sticker shock, the TCO is actually quite compelling, & value is high
2. The new quad-core z10 processor runs at 4.4GHz and is 50% faster than the z9
3. Actually, >350 large and 1300 midsize clients are growing their MIPS by >30% & their z spend by 11% CAGR, in a -3% market
4. IBM has increased investments by \$100's M on z technology and field resources
5. Perhaps, unless you are executing lots of threads, have a lot of servers, or accessing lots of data (sound familiar?)
6. IBM realizes synergy between Power, z, and Software Group, delivering significant shareholder and client value

System z – Overview and Brief History

- **System/360 – April 9, 1964**
 - ▶ 24-bit, 1-2 CPUs
 - ▶ General purpose family of computers
- **System 370/XA - 1981**
 - ▶ 31-Bit, 1-4 CPUs
 - ▶ I/O Subsystem
- **ESA/370 - 1988**
 - ▶ 31-bit, 1-6 CPUs
 - ▶ PR/SM
- **ESA/390 – 1990**
 - ▶ 31-bit, 1-12 CPUs
 - ▶ EMIF, ESCON and FICON Channels
- **z/Architecture – 2000**
 - ▶ 64-Bit, 1-64 CPUs
 - ▶ Specialty Processors

