

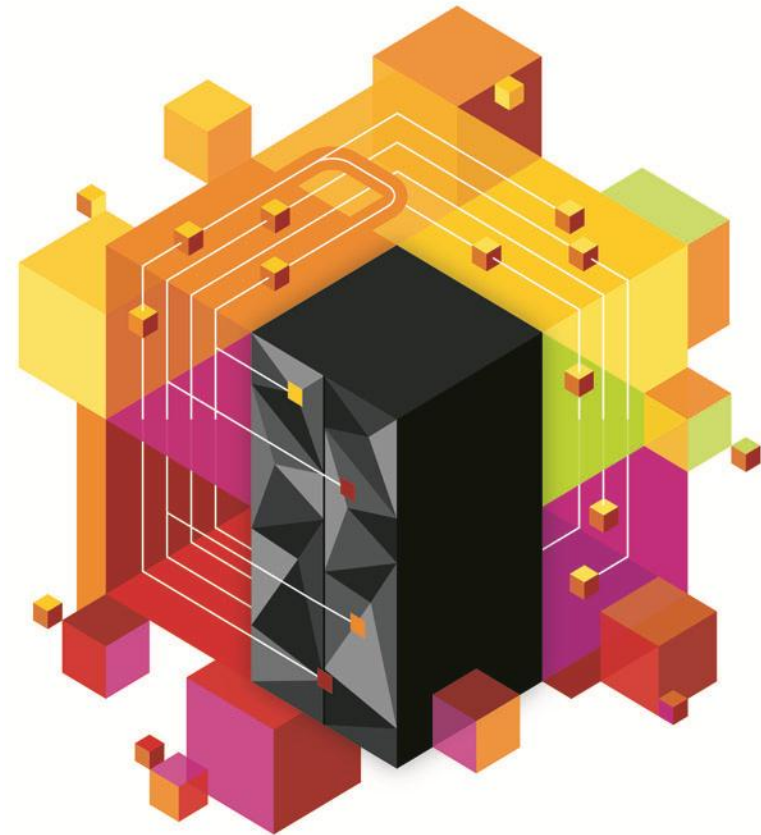

IBM zEnterprise Technology Summit

The New zEnterprise –
A Cost-Busting Platform

Best Fit Workloads
For System z Private Clouds



Private Cloud On System z

Two Cost Reducing Strategies...

**Reduce Hardware
and Software Costs**

**Consolidate
and Virtualize**

**IBM zEnterprise EC12
with Linux on z/VM**

**Reduce Labor Costs
and Improve Agility**

**SmartCloud
Provisioning**

**Automate
Operations**

Examples of Workloads Best Suited To Consolidate On Linux On z/VM

Workloads with high I/O demand



Smaller scale transaction processing workloads

Workloads with co-location requirements



Systems of engagement workloads

Workloads requiring high availability and qualities of service



Applications critical to business revenue

Consolidation of large numbers of mixed priority workloads



Mixed high priority and low workloads

A Closer Look At z/VM and Linux

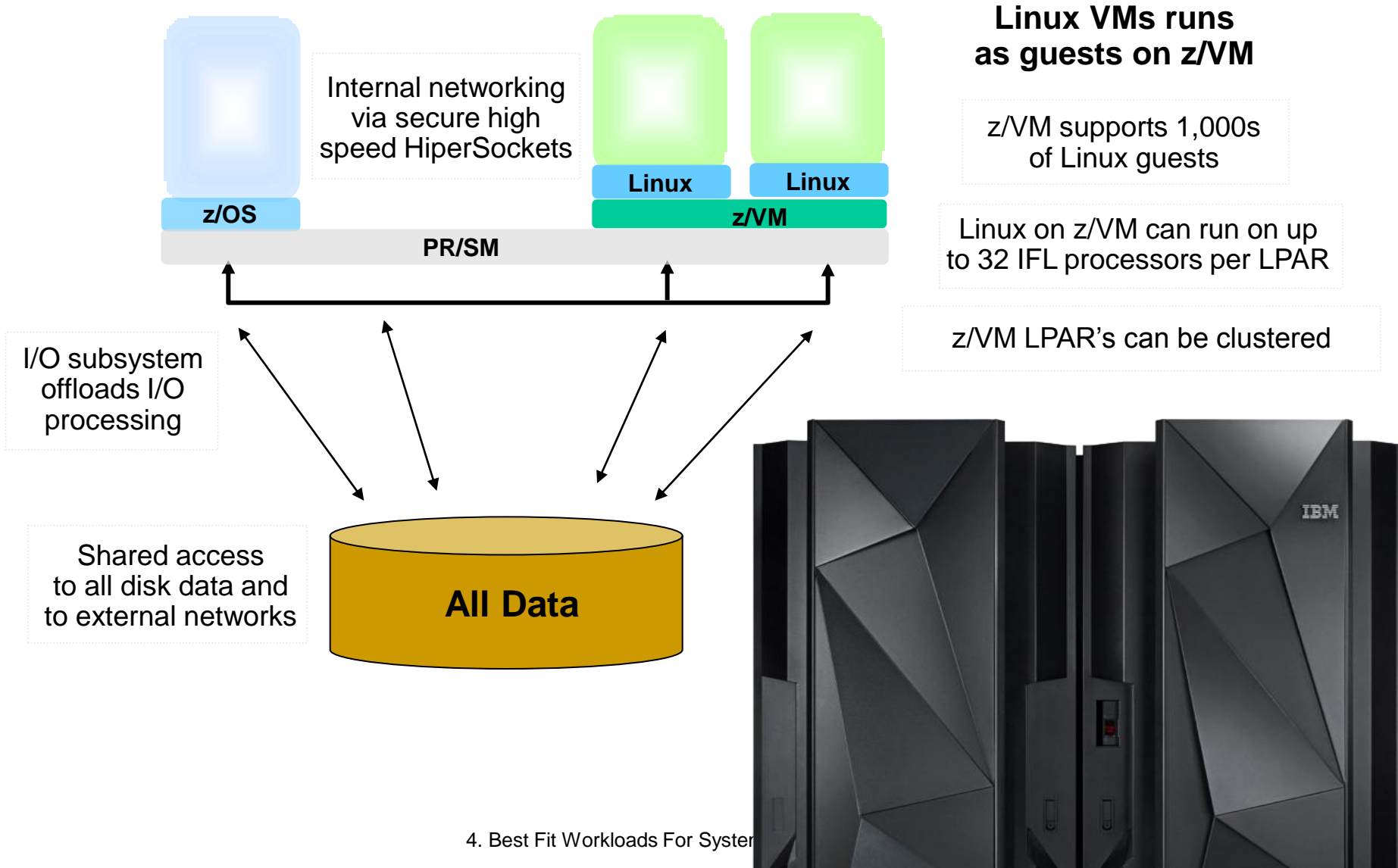

System z With IFL Processors Delivers Unmatched Capacity

- zEC12 has 120 total processors –
 - 101 can be configured as IFLs for Linux
 - ▶ IFLs have same performance characteristics as general purpose processors
 - ▶ All processors run at world's fastest clock rate – 5.5 GHz
 - ▶ Exceptional cache structure, and up to 3 TB memory
- More than 78,000 IFL MIPS at maximum
- Significantly discounted pricing for IFLs
- Software running on IFLs is licensed by PVU, not MLC (zEC12 = 120 PVU's)
- Solution Edition pricing can be even more attractive

6 processors per chip

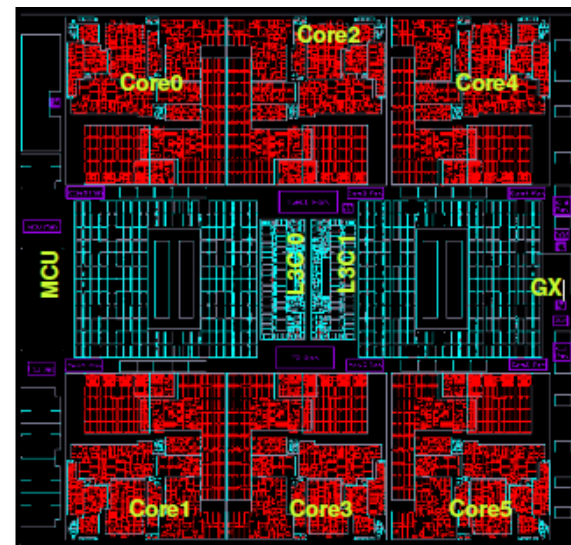

Multi-Chip Module



Linux On z/VM Workloads Get The Benefit Of System z Dedicated I/O Subsystem

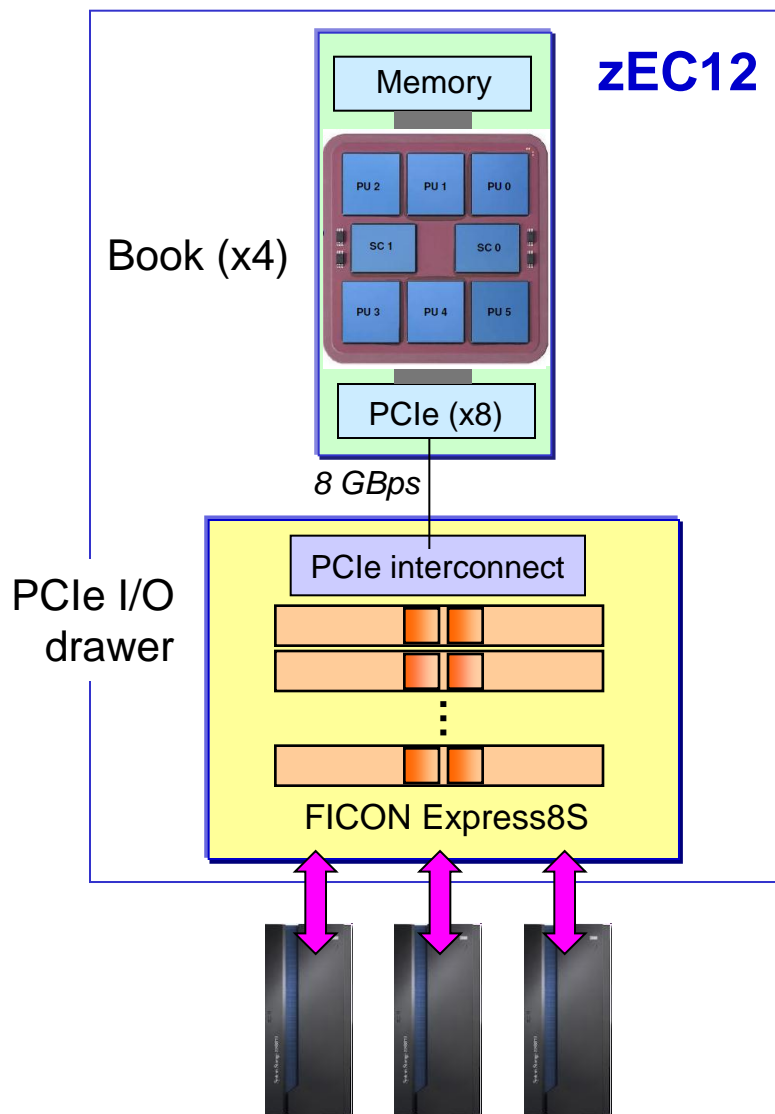

- Specialty processors handle all I/O requests – System Assist Processors (SAPs)
 - ▶ Max of 16 SAPs can sustain up to 2.4M IOPS*
 - ▶ I/O subsystem bus speed = 8 GBps
- Up to 160 physical FICON cards for I/O transfers
 - ▶ Up to 320 RISC processors (2 per card)
 - ▶ Up to 320 FICON channels (2 per card)
 - ▶ 8 Gbps per link, 288 GB/Sec I/O aggregate per zEC12
- IBM DS8800 Storage System
 - ▶ Up to 440K IOPS capability

* Recommend 70% max utilization – 1.7M IOPS
Numbers represent High Performance FICON traffic

Workloads With Higher I/O Bandwidth Requirements Benefit From System z Architecture

Which platform provides the lowest TCA over 3 years?

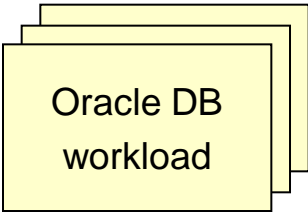

3 Database Workloads
Oracle Enterprise Edition
Oracle Real Application Cluster



3 Oracle RAC clusters
4 server nodes per cluster
12 total Oracle T3-4 servers
(768 cores)

\$28.7M (3 yr. TCA)



3 Oracle RAC clusters
4 nodes per cluster
Each node is a Linux on z guest
zEC12 with 27 IFLs

\$5.7M (3 yr. TCA)

80% less cost!

TCA includes hardware, software, maintenance, support and subscription. Workload Equivalence derived from a proof-of-concept study conducted at a large Cooperative Bank and projecting to T3-4 servers using published TPC-C Results normalizing them to Relative Performance Units as available from Ideas International

City And County Of Honolulu Benefit From System z Architecture

Business challenge:

The City and County of Honolulu wanted to increase government transparency and provide more information, such as the city's financial data, to its citizens.

Solution:

Honolulu deployed an Integrated Facility for Linux (IFL) engine running Linux on IBM System z. This provided the necessary platform to provide the city's data to citizens, and it enabled the city to create a custom cloud environment to deploy applications.

Benefits:

- *Reduced database licensing costs by **68** percent*
- Reduced time to deploy applications from 1 week to only hours
- Increased property tax revenue by \$1.4M

“Working with IBM enabled us to take an innovative approach... we were able to get things up and running quickly.”

—Gordon J. Bruce, director and CIO of the Department of Information Technology, City and County of Honolulu

Solution components

Optimized systems:

- IBM System z with IFL engine running Linux
- IBM XIV Storage System
- IBM Tivoli software

Co-location Benefit From System z Architecture

Separate Machines

Separate LPARs

270 tps $\xrightarrow{33\%}$ 360 tps

4 CPUs

2 CPUs

1 CPUs

2 CPUs

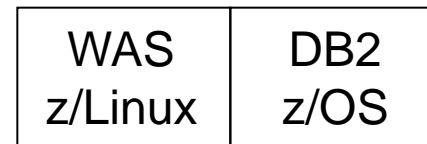
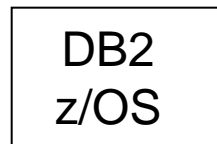

T4



Power System

System z



T4

System z

SAP Applications Benefit From Co-location



Business challenge:

Baldor needed to **cut costs** while simultaneously enhancing customer service with very **rapid** order processing, responsive manufacturing and swift delivery.

Solution:

Migrated its mission-critical SAP and DB2-based applications to an IBM System z running Linux, z/OS and z/VM operating systems, eliminating several large Sun servers in the process.

Benefits:

- Reduced IT costs as proportion of sales by **50%**
- Consolidation cuts power by **40%** and reduces data center floor space from 6,000 to 1,000 sq ft
- Cut system administration and maintenance costs

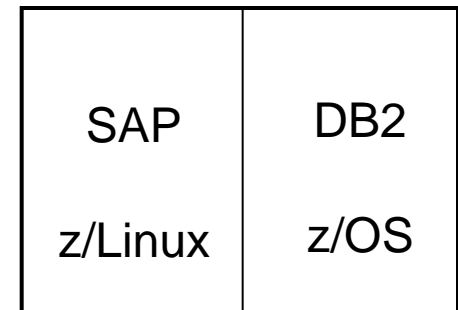

SAP Applications
Co-located on System z

US Manufacturing Customer Consolidates Low Utilization Servers On System z

Before:



Factory automation workload
Average utilization = 2%

200 Sun x4100 servers
(800 cores)

\$4.48M (5 yr. TCO)

After:



2 z114 servers
(2 IFLs per server)

\$1.45M (5 yr. TCO)

68% lower TCO

TCO includes hardware, software, maintenance, support and subscription, labor power, space and 2 years migration costs. DR not included.

Linux On z/VM Workloads Inherit System z Qualities Of Service

- Add processing capacity to Linux environment without disruption
- Capacity on demand upgrades
- Reliability, availability, serviceability
- Site failover for disaster recovery



DEMO: Dynamically Add Processing Capacity To z/VM LPAR To Handle Increased Workload Without Disruption

1. A customer has in-house Risk Analysis program running on Linux on System z
2. Increased workload to all 4 Linux guests is causing z/VM LPAR utilization of 90%+
3. Customer determines this is a long term trend - additional physical capacity needed
4. New capacity made available to LPAR as new Logical CPU, available for work
 - ▶ Without disruption in service

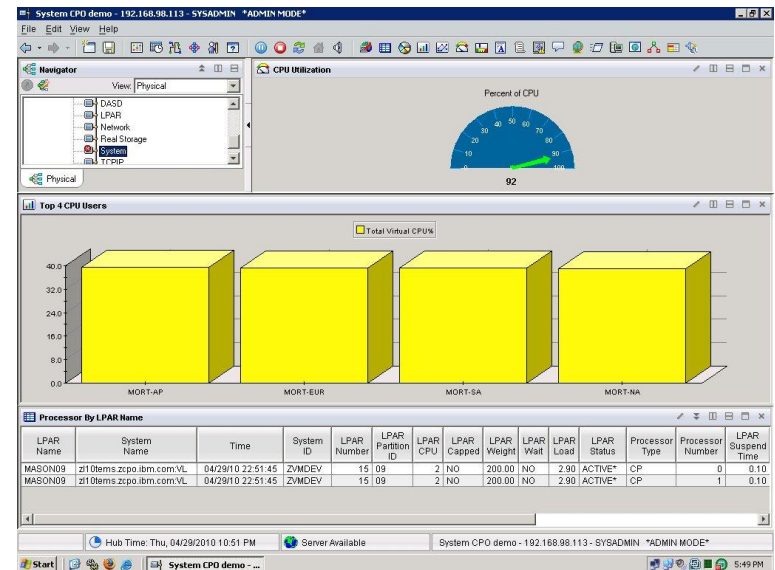

Note: Assumes available processors on installed books

System z Capacity On Demand Provides Physical Processors To Handle Unexpected Peaks

- Capacity on Demand
 - ▶ “Books” are shipped fully populated
 - ▶ Activate dormant processors as needed
 - ▶ Use for temporary or permanent capacity
 - ▶ Self-managed on/off
- New capacity is immediately available for work without service disruption

One Book with 36 Processors

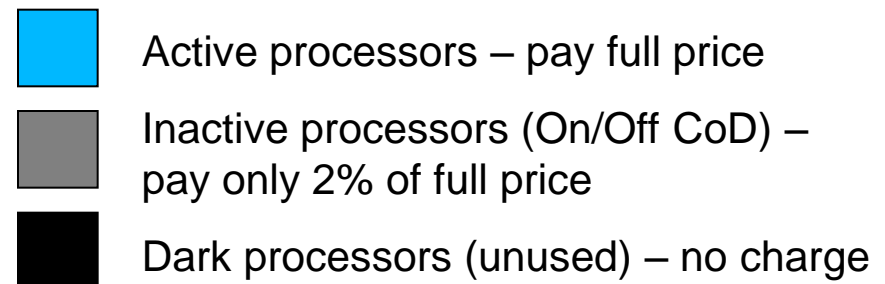
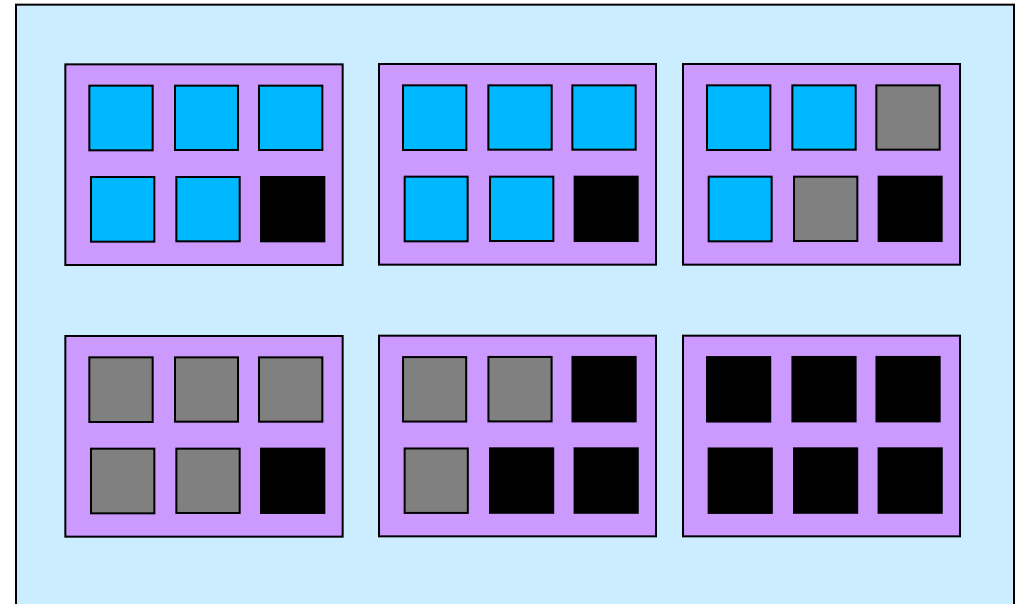

Transzap Benefits From High Reliability

Business challenge:

As a small business with tens of billions of dollars in client transactions flowing through their systems each year, Transzap needed an economical, reliable platform to provide clients with **high availability** while enabling the capacity to accommodate triple digit **growth** within their software as a service business model.

Solution:

Transzap migrated to System z and virtualized its critical applications on Linux on System z, a platform that supports Transzap's dynamic Java™ and Oracle environments.

Benefits:

- Helps Transzap to serve more than 69,000 users across 6,800 companies
- Provides higher levels of **uptime** for their customers
- Offers peace of mind through 24x7 world-class hardware support

*“We intend to deliver a **99.9% application uptime guarantee** to our customer base, thanks to the availability characteristics of System z.”*

— Peter Flanagan, CEO of Transzap, Inc.

Solution components:

- IBM System z
- Linux on System z
- IBM z/VM



ZSP03141-USEN-00

Local Government Consolidates BI Workloads On Linux On System z For Improved Reliability

Which platform provides the lowest TCA over 3 years?

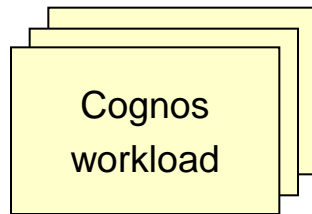

21 Cognos Report Workloads

Cognos 10 BI



21 HP DL580 Wintel servers
(Xeon 2.13 GHz, 1ch/8co)
168 cores total

\$3.32M (3 yr. TCA)



(Cognos runs as a zVM
Linux on System z guest)

zEC12 with 2 IFLs

\$0.40M (3 yr. TCA)



zEC12

88% lower cost!

TCA includes hardware, software, maintenance, support and subscription. Software includes WebSphere and OS. Cognos 10 BI software cost is same for both environments since it is priced per authorized user and hence not included. Case study derived from a customer scenario in government industry.

Many Customers Are Realizing The Benefits Of Consolidating On Linux On z/VM

- 
- Atos Origin
 - AutoData Norg AS
 - Baldor
 - Banco Pastor
 - Bank of New Zealand
 - Bankia
 - BG-Phoenics
 - BSBC Minnesota
 - Business Connecion
 - City of Honolulu
 - Colacem S.p.A.
 - Computacentre
 - Dundee City
 - Efis EDI Finance
 - El Corte Ingles
 - Embasa
 - Endress+Houser
 - EuroControl MUAC
 - gkd-el
 - IBM Blue Insight
 - Liberty Mutual
 - Marist
 - Marsh
 - Miami Dada County
 - National Registration Dept
 - Nationwide
 - NWK
 - Procempa
 - RCBC
 - RENFE
 - Salt River Project
 - Shelter Mutual Insurance
 - Shikoku Electric
 - Sparda Datenverarbeitung eG
 - Svenska Handelsbanken
 - Swiss Re
 - Transzap
 - Univeristy of Bari
 - University of Arkansas
 - University of NC
 - VietinBank

Over 11,000 IFL processors installed worldwide (BC and EC)

Private Cloud On System z

Two Cost Reducing Strategies...

**Reduce Hardware
and Software Costs**

**Consolidate
and Virtualize**

**IBM zEnterprise EC12
with Linux on z/VM**

**Reduce Labor Costs
and Improve Agility**

**SmartCloud
Provisioning**

**Automate
Operations**

Automate Workload Deployment With IBM SmartCloud Provisioning

- Self-service automated provisioning of virtual machine images...
- ...into pools/clouds of external virtualized hardware
 - ▶ Can deploy to various virtualized platforms
 - ▶ Supports zVM, PowerVM, VMware ESX hypervisors
- Supports IBM patterns
 - ▶ Deploy multiple virtual machines in a single operation
 - ▶ Images can include middleware and applications

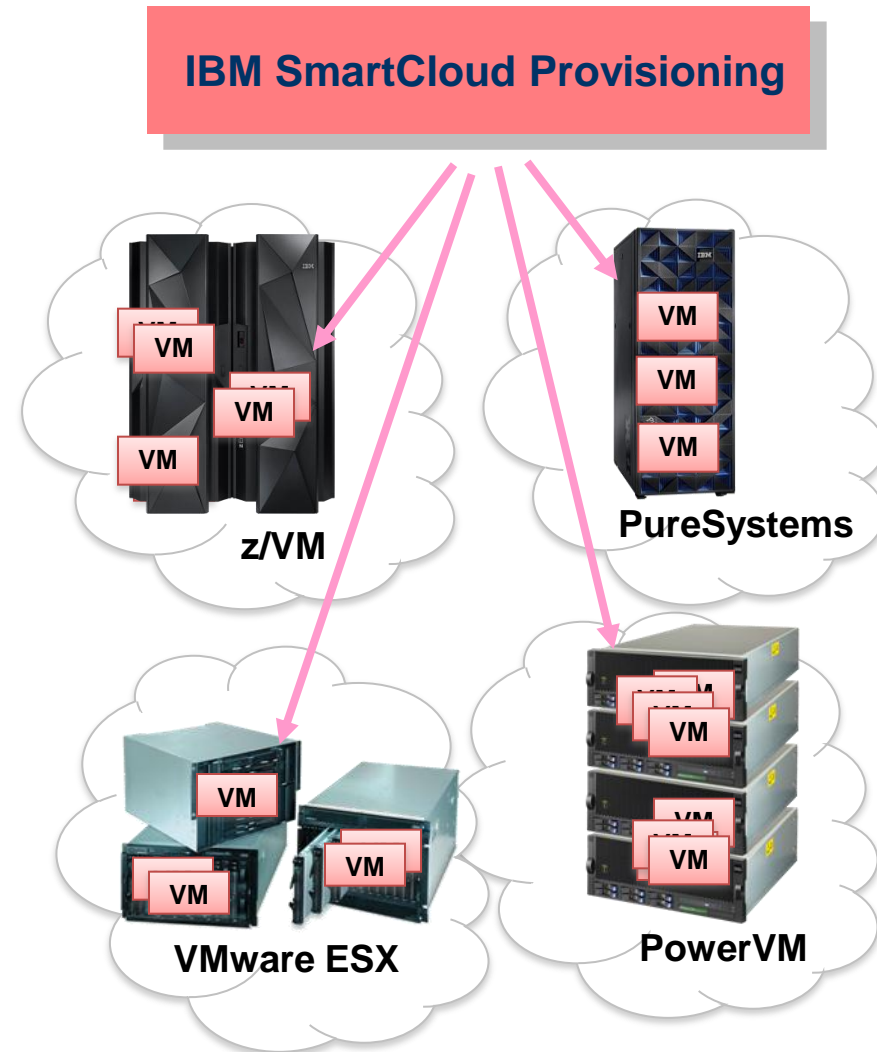

Automation With IBM SmartCloud Provisioning Can Further Reduce Costs



User selects and deploys a pattern

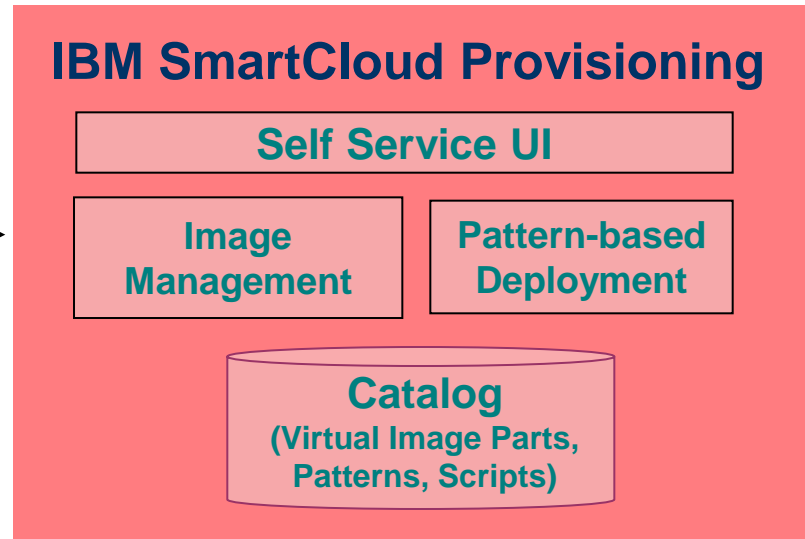

- Self-service console for users
- Virtual images and patterns for quick-starts
- Drag and drop tooling for creating and deploying virtual applications using catalog
- Intelligent placement algorithm optimize resource utilization based on cloud activity

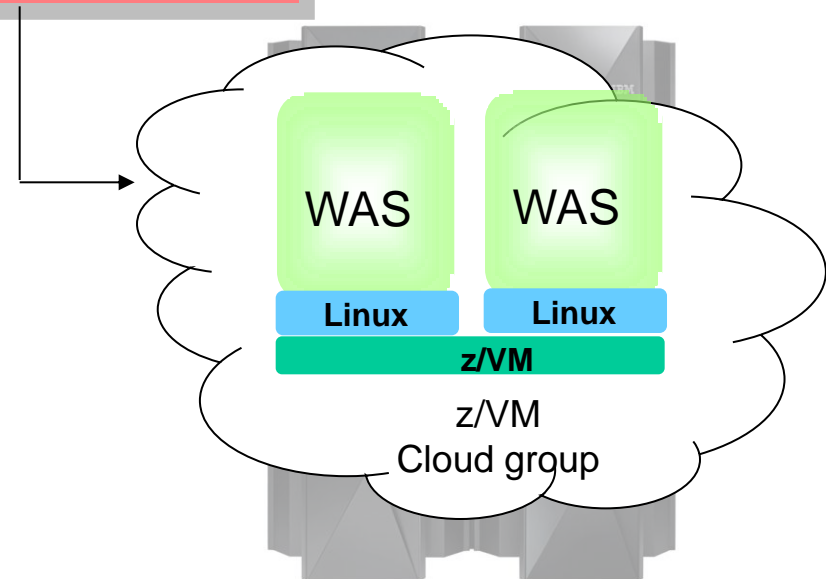

IBM SmartCloud Provisioning Makes It Easier To Get Started With Virtualized Images

- IBM middleware packaged as Hypervisor Editions (.OVF virtual images), ready to run on a hypervisor
 - ▶ Includes pre-installed and pre-configured image, image-specific tuning/configuration and fast deploy-time activation capabilities
- Hypervisor Editions (HV) offered for z/VM include:
 - ▶ WebSphere Application Server
 - ▶ WebSphere Process Server
 - ▶ WebSphere Portal Server
- Hypervisor Editions imported into SmartCloud Provisioning catalog as virtual image parts that represent topology components
 - ▶ Example: deployment manager, custom node, etc.
- Virtual image parts can be used to create virtual system patterns

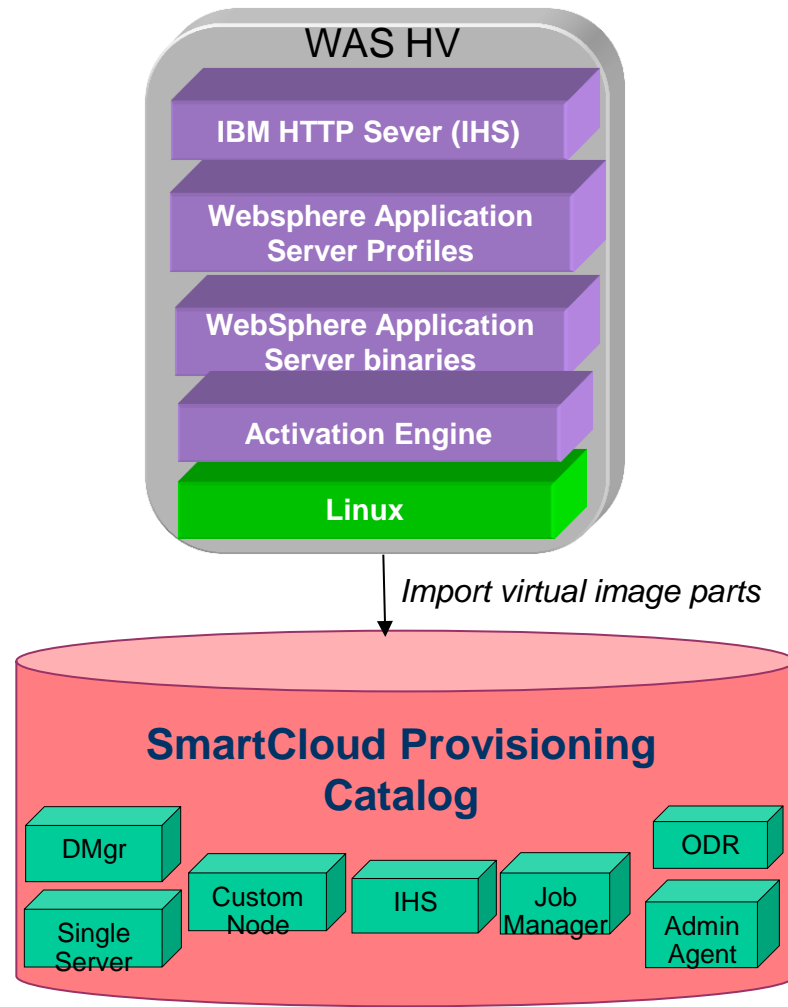

IBM SmartCloud Provisioning Deploys Standardized Virtual System Patterns

A Virtual System Pattern is one or more virtual images and script packages to satisfy a certain deployment topology

Single Server

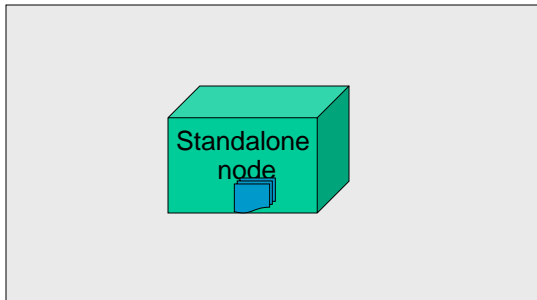

WebSphere cluster

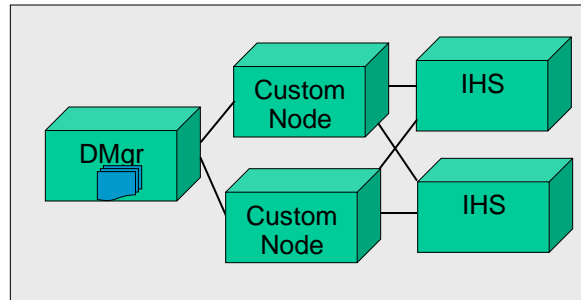

WebSphere Advanced Cluster

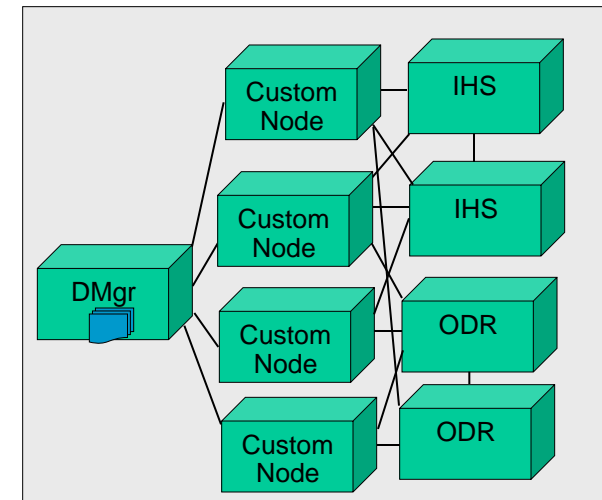

WebSphere cluster (dev)

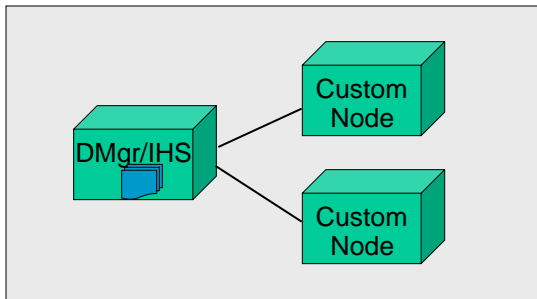

WebSphere Process Server (Scalable)

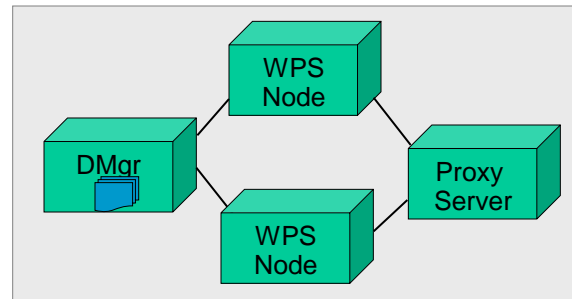

DMgr = Deployment Manager
IHS = IBM http Server
ODR=On Demand Router

Example: Use A Pattern For Automated Deployment Of Single WAS Server

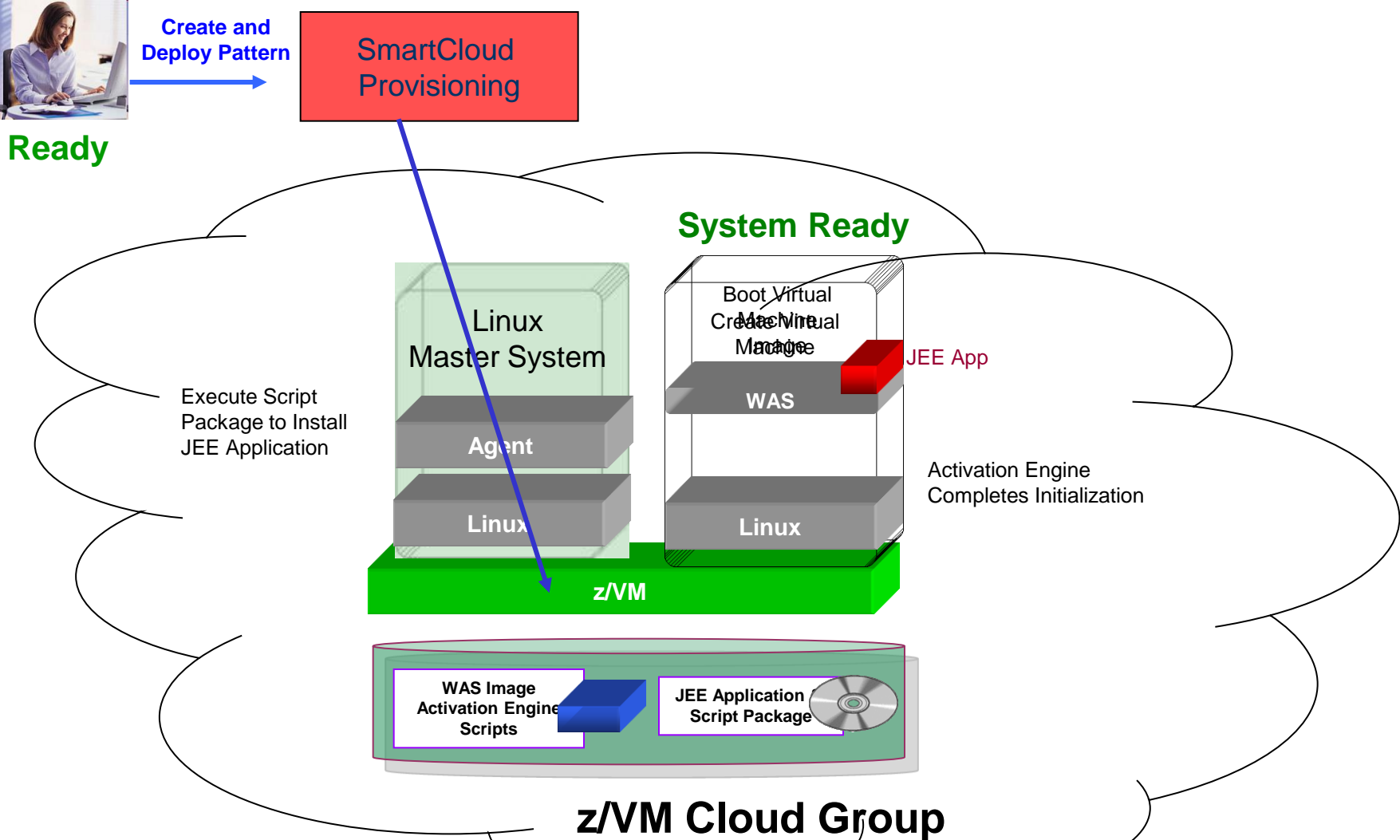

IBM SmartCloud Provisioning Automated Pattern-Based Deployment Is Fast

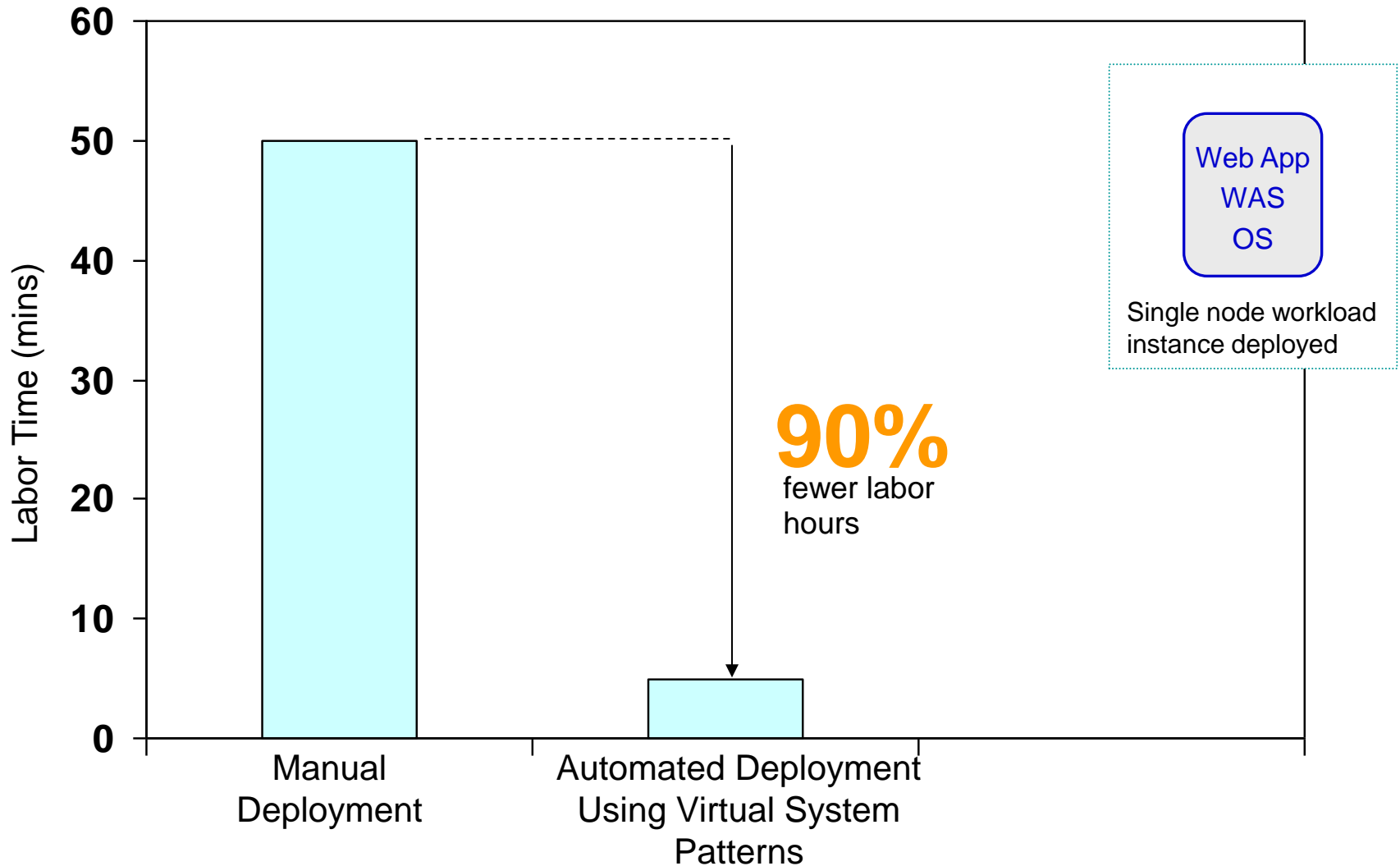

Normal Deployment Steps For WAS High Available Clustered Environment

1. Involves creating 4 virtual servers
 - ▶ 1 WebSphere deployment manager
 - ▶ 2 WebSphere Node
 - ▶ 1 IBM HTTP Server
2. Install the WAS Update Installer and install the required iFixs
3. Create WebSphere Cluster with 2 members
4. Configure the HTTP Server
5. Configure Session replication on servers to support Failover
6. Deploy the Application to the WebSphere Cluster

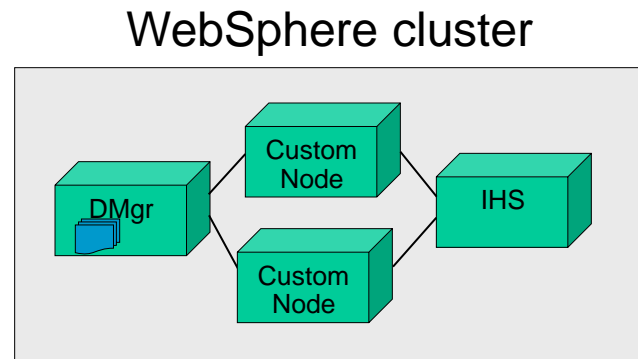

All of these steps are done automatically with IBM SmartCloud Provisioning

DEMO: Fast Deployment Of WAS Cluster With IBM SmartCloud Provisioning

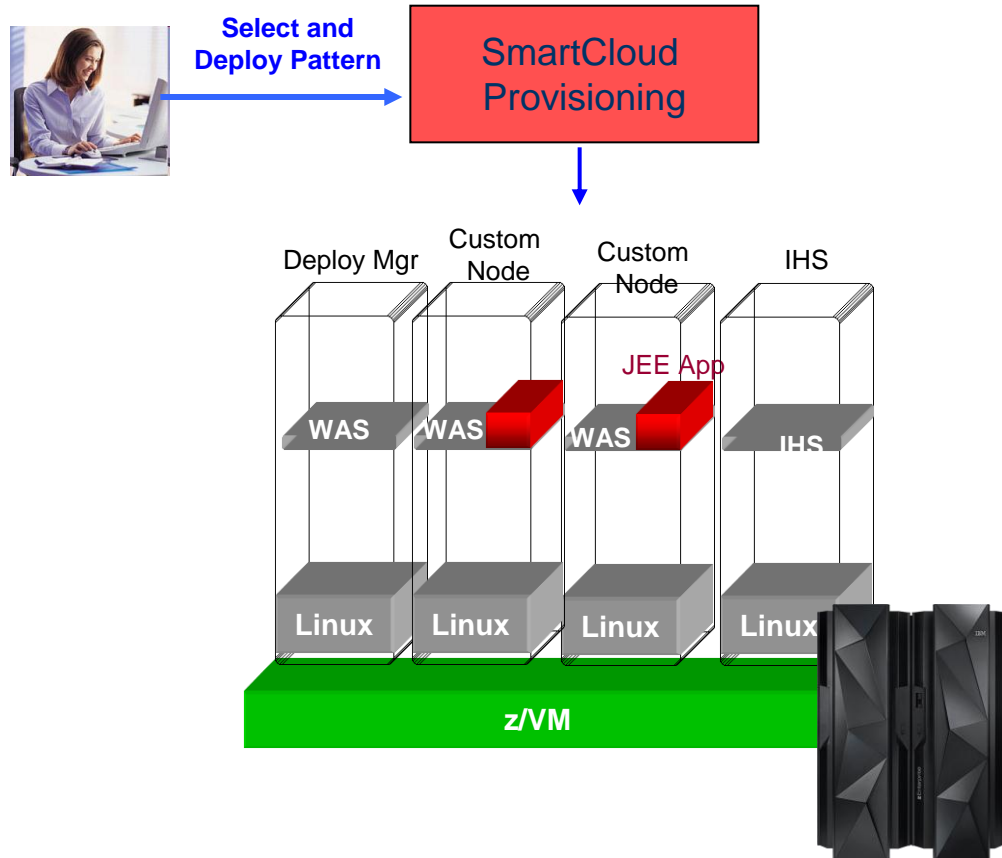

- Self-service console
- Drag and drop pattern editor to create a WAS cluster pattern
- Automated provisioning of the cluster

Which Option Requires The Least Amount Of Labor?

Which platform provides the lowest labor costs over 3 years?

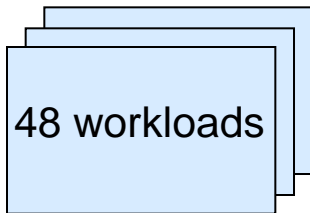

Online banking workloads, each driving **22** transactions per second, with **1 MB I/O** per transaction

48 Sun Fire X4170 M2



1
z/VM on zEC12
32 IFLs

A High-Level View Of The Labor Model

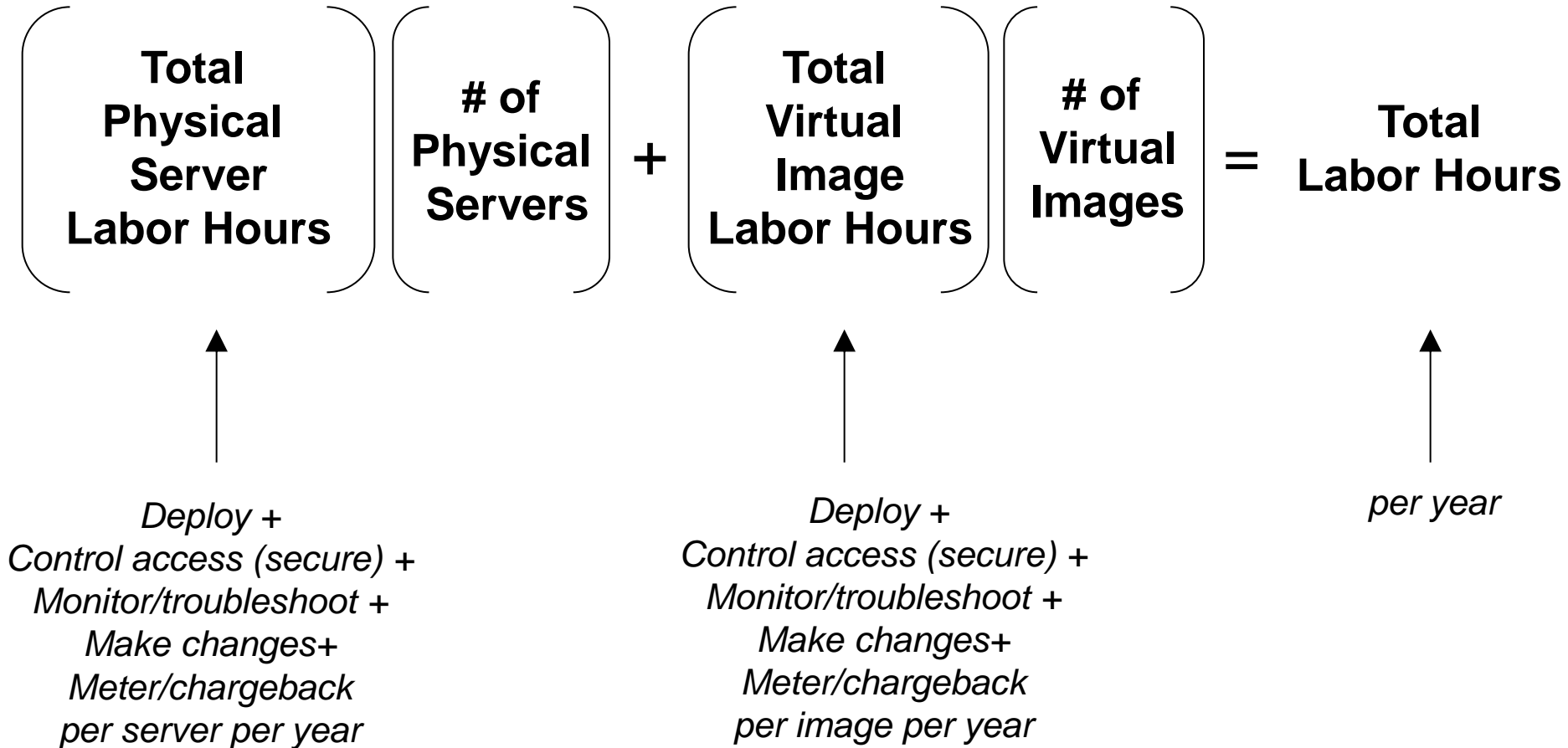

Note: Labor model best fit to field data

A High-Level View Of The Labor Model

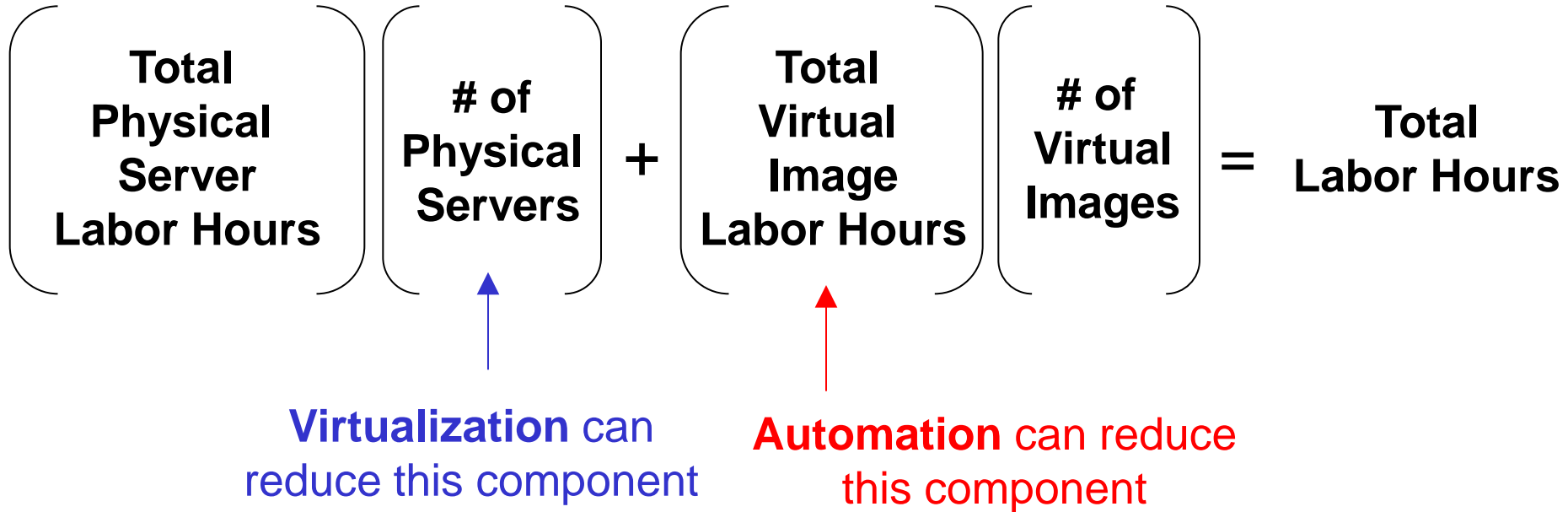

IBM SmartCloud Provisioning Cuts Labor Costs

Case Study With 48 Workloads

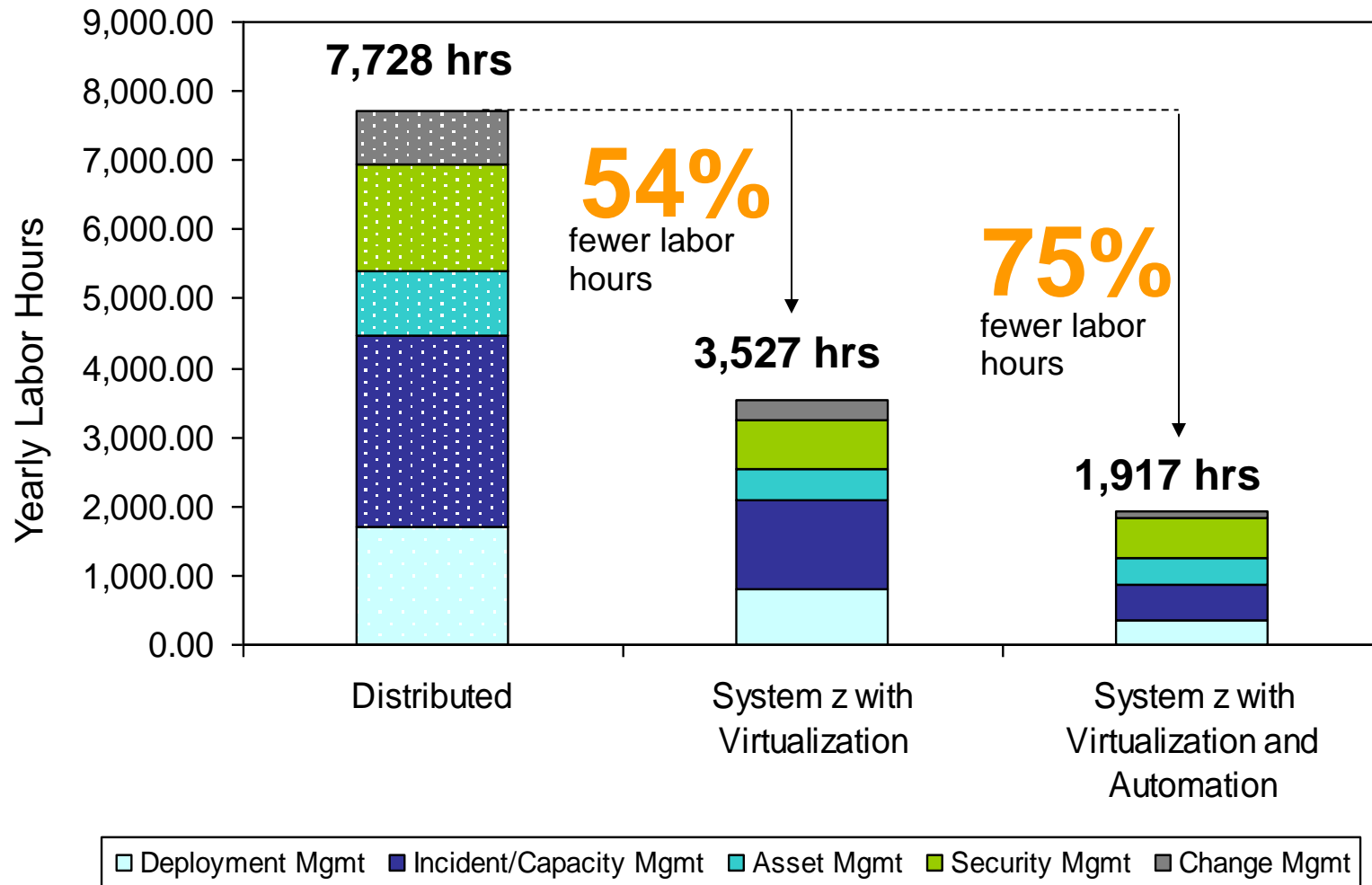

IBM SmartCloud Provisioning Cuts Labor Costs

Change Mgmt –

- Visibility into relationships of virtual images in a workload
- Automatically apply changes to desired virtual servers

Security Mgmt –

- Centrally access control

Asset Mgmt –

- Track license usage of products

Incident/Capacity Mgmt –

- Centrally monitor and resolve issues

Deployment Mgmt –

- Fast pattern-based deployment

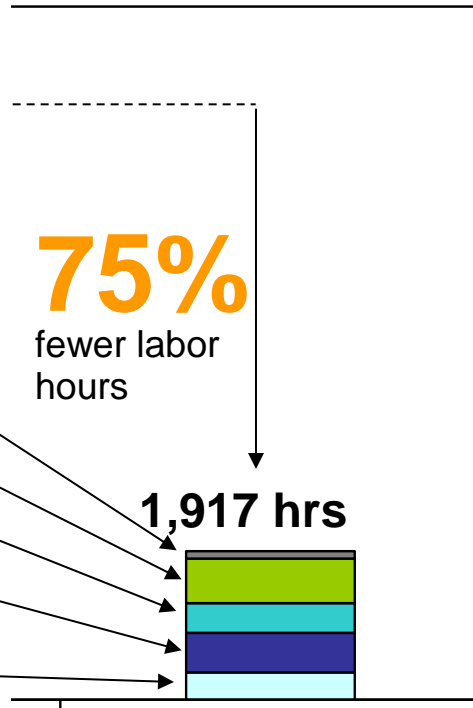

Deployment Mgmt Incident/Capacity Mgmt Asset Mgmt Security Mgmt Change Mgmt

Reduce Costs With A System z Private Cloud

Example With 48 Workloads

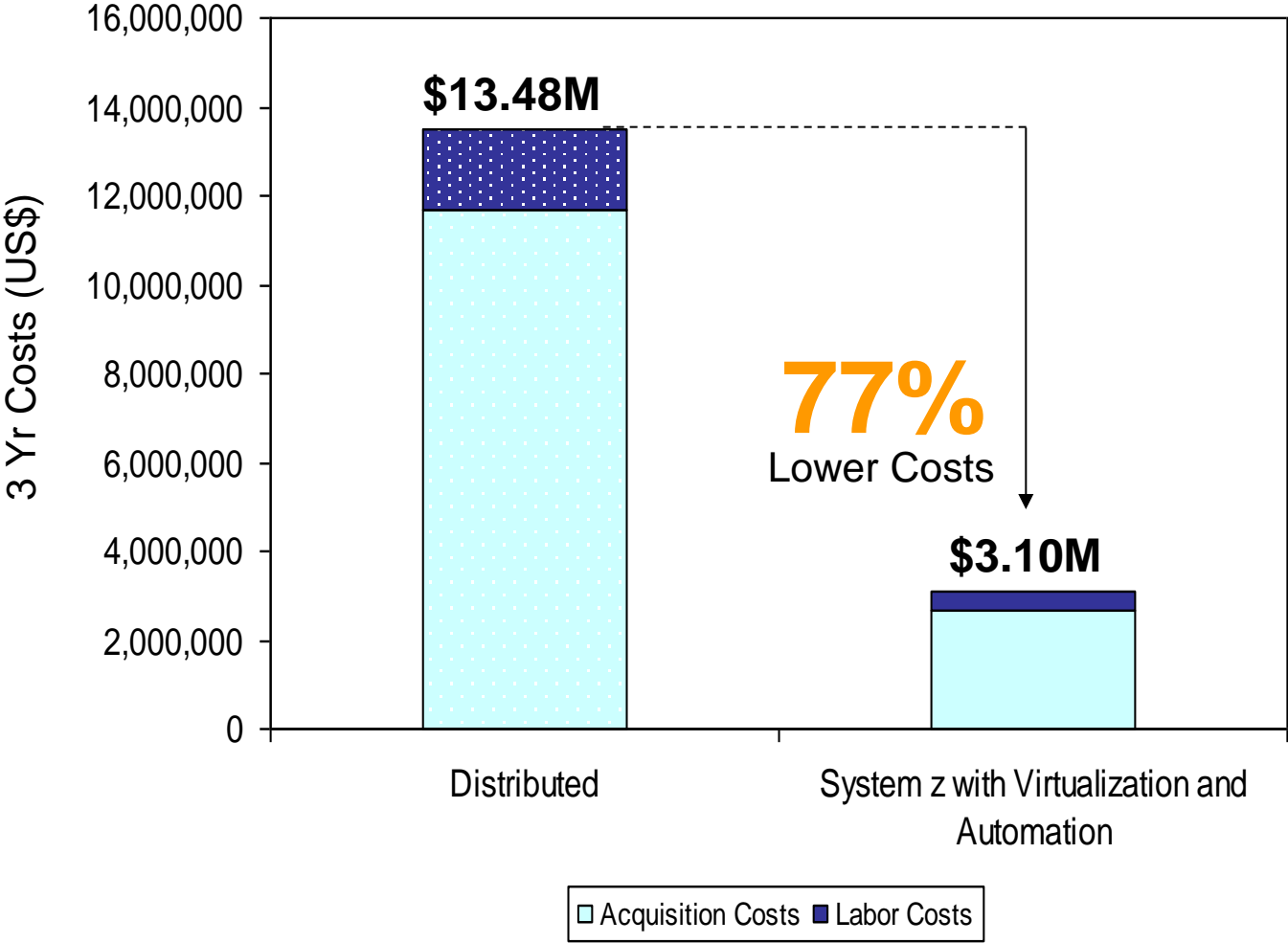

Note: 3 year TCO includes hardware acquisition, maintenance, software acquisition, S&S and labor. US pricing and will vary by country.

Reduce Costs With A System z Private Cloud

Two Cost Reducing Strategies...

**Reduce Hardware
and Software Costs**

**Consolidate
and Virtualize**

**IBM zEnterprise EC12
with Linux on z/VM**

**Reduce Labor Costs
and Improve Agility**

**SmartCloud
Provisioning**

**Automate
Operations**



Notice Regarding Specialty Engines (e.g., zIIPs, zAAPs and IFLs):

Any information contained in this document regarding Specialty Engines ("SEs") and SE eligible workloads provides only general descriptions of the types and portions of workloads that are eligible for execution on Specialty Engines (e.g., zIIPs, zAAPs, and IFLs). IBM authorizes customers to use IBM SE only to execute the processing of Eligible Workloads of specific Programs expressly authorized by IBM as specified in the "Authorized Use Table for IBM Machines" provided at www.ibm.com/systems/support/machine_warranties/machine_code/aut.html ("AUT").

No other workload processing is authorized for execution on an SE.

IBM offers SEs at a lower price than General Processors/Central Processors because customers are authorized to use SEs only to process certain types and/or amounts of workloads as specified by IBM in the AUT.