

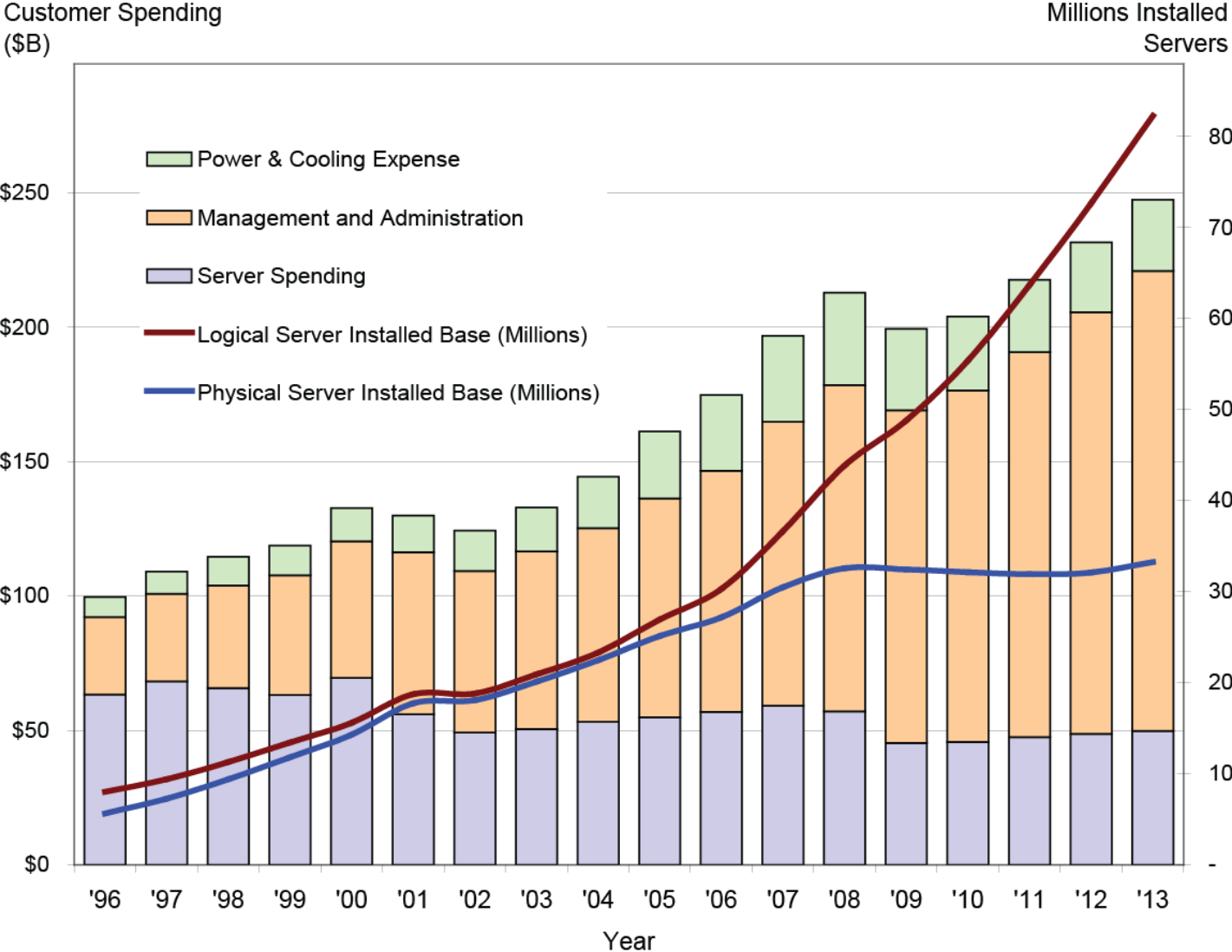

# **Best Fit Workloads For System z Private Cloud**

The New zEnterprise –  
A Cost-Busting Platform

# Annual IT Costs Keep Rising



Source: IDC, 2011

# Cloud Technologies Can Help Reduce Costs And Improve Agility

Let's first see how we can reduce costs with virtualization on System z...



**Reduce Hardware,  
Software, and Labor  
Costs**

**Reduce Labor Costs  
Improve Agility**

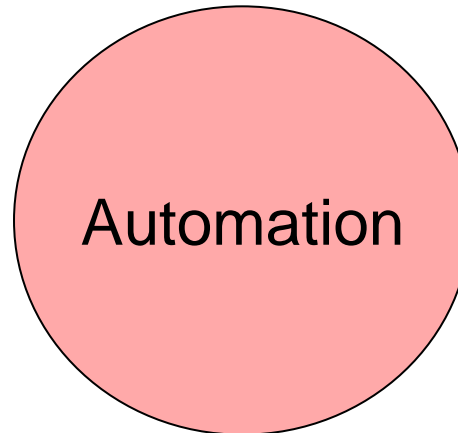
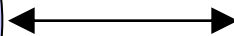
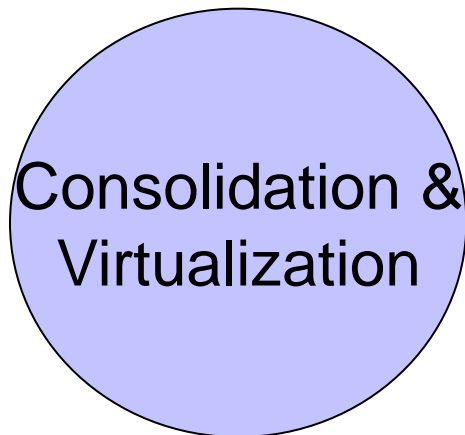

# Certain Workloads Are Best Suited To Consolidate On Linux On System z

- High I/O bandwidth
  - ▶ Example: Transaction processing applications
  - ▶ I/O operations offloaded to SAPs to improve performance
- Co-location
  - ▶ Example: Application front ends
  - ▶ Less latency to improve performance
- High reliability
  - ▶ Example: Applications critical to business revenue
  - ▶ Industry best platform for high availability and disaster recovery
- High number of light workloads
  - ▶ Example: Applications with low utilization
  - ▶ z/VM can define thousands of virtual machines

# Other Advantages To Consolidate On Linux on System z

- Lower acquisition costs
  - ▶ High consolidation ratios and economics of Specialty Engines (IFLs) and Solution Edition Pricing provide significantly lower total costs of acquisition
- Lower labor costs
  - ▶ Consolidated workloads are easier to manage

# A Closer Look At Linux On z/VM

## Logical Partitions Share Processors, Common Cache Structures, and I/O

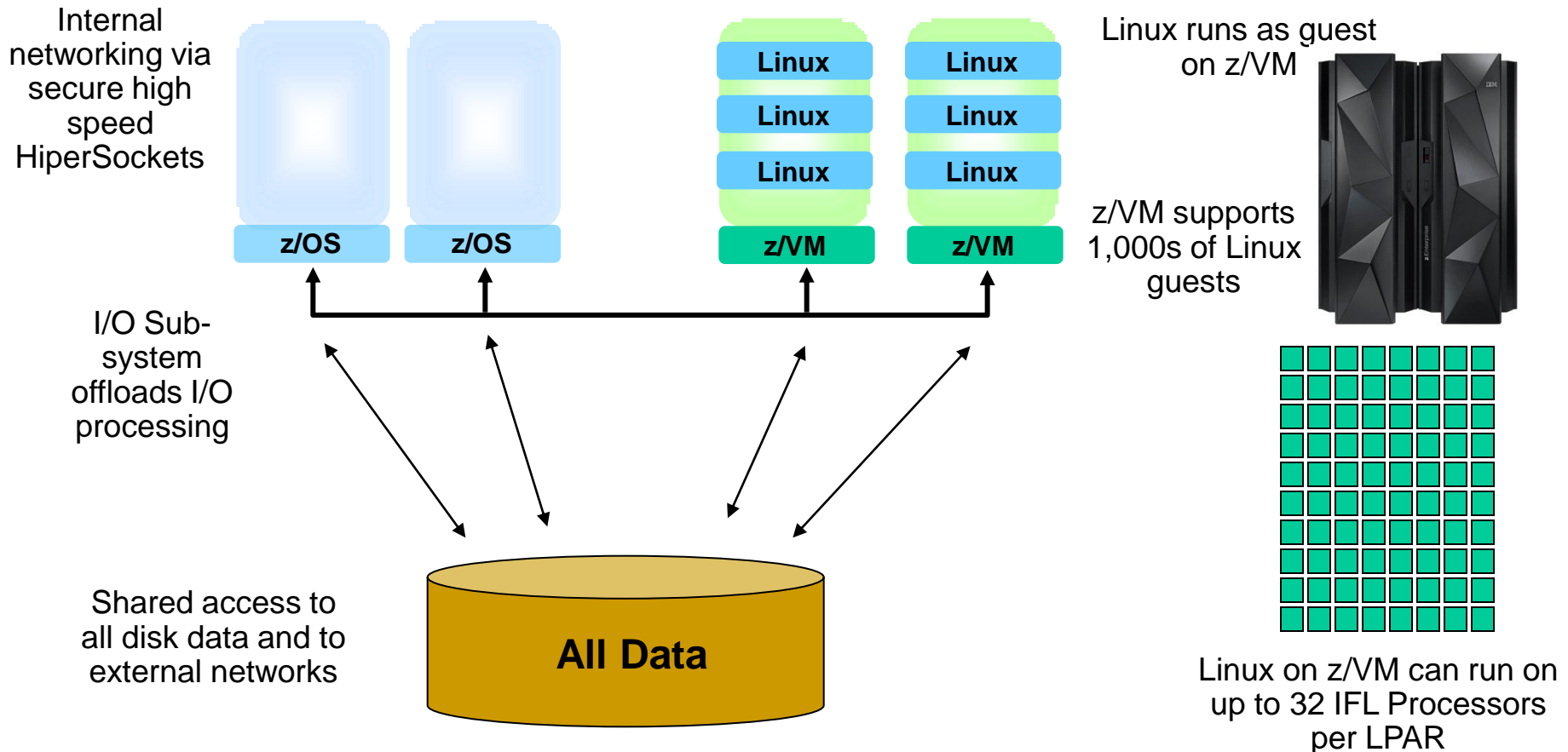

# z/OS And z/VM Get The Benefit Of High I/O Bandwidth

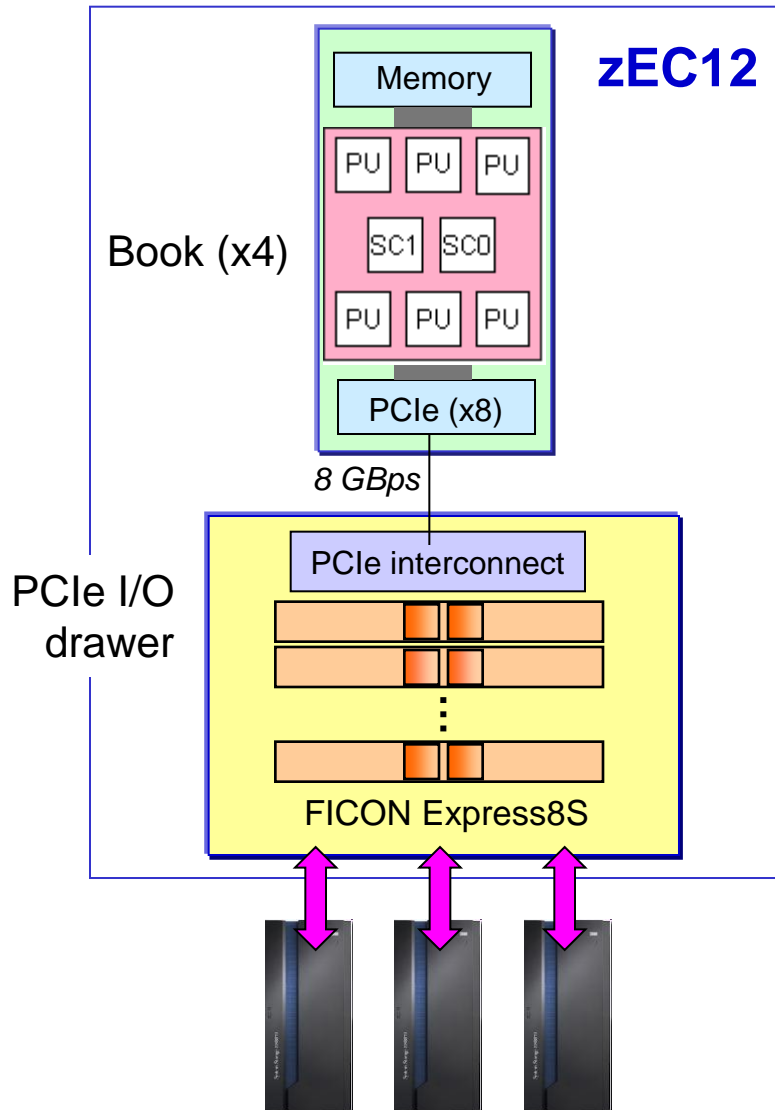

- At minimum, 2 core per server are configured as System Assist Processors (SAPs)
  - ▶ All I/O requests are offloaded to SAPs
  - ▶ Number of SAPs increases with capacity up to a maximum of 16 in a fully loaded system
  - ▶ Each SAP can sustain up to 2.4M IOPS\*
  - ▶ I/O subsystem internal bus interconnect speed of 8 GBps
- Up to 160 physical FICON cards for I/O transfers
  - ▶ Up to 320 RISC processors (2 per card)
  - ▶ Up to 320 FICON channels (2 per card)
- IBM DS8800 Storage System
  - ▶ Up to 440K IOPS capability
- Delivers efficiency at scale

\* Recommend 70% max utilization – 1.7M IOPS  
Numbers represent High Performance FICON traffic

# High I/O Bandwidth Benefit From System z Architecture

*Which platform provides the lowest TCA over 3 years?*

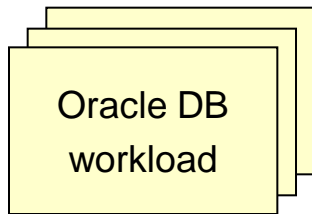

3 Database Workloads  
Oracle Enterprise Edition  
Oracle Real Application Cluster



3 Oracle RAC clusters  
4 server nodes per cluster  
12 total Oracle T3-4 servers  
(768 cores)

**\$28.7M** (3 yr. TCA)



3 Oracle RAC clusters  
4 nodes per cluster  
Each node is a Linux on z guest  
zEC12 with 27 IFLs

**\$5.7M** (3 yr. TCA)

**80% less cost!**

TCA includes hardware, software, maintenance, support and subscription. Workload Equivalence derived from a proof-of-concept study conducted at a large Cooperative Bank and projecting to T3-4 servers using published TPC-C Results normalizing them to Relative Performance Units as available from Ideas International



# City And County Of Honolulu Benefit From System z Architecture

## Business challenge:

The City and County of Honolulu wanted to increase government transparency and provide more information, such as the city's financial data, to its citizens. Honolulu also wanted to increase community involvement and improve the efficiency of its work order system.

## Solution:

Honolulu deployed an Integrated Facility for Linux (IFL) engine running Linux on IBM System z. This provided the necessary platform to provide the city's data to citizens, and it enabled the city to create a custom cloud environment to deploy applications.

## Benefits:

- *Reduced database licensing costs by 68 percent*
- Reduced time to deploy applications from 1 week to only hours
- Increased property tax revenue by \$1.4M

*“Working with IBM enabled us to take an innovative approach. Instead of following the long processes of other governments or even the private sector, we were able to get things up and running quickly.”*

*—Gordon J. Bruce, director and CIO of the Department of Information Technology, City and County of Honolulu*

## Solution components

### Optimized systems:

- IBM System z with IFL engine running Linux
- IBM XIV Storage System
- IBM Tivoli software

# Co-location Benefit From System z Architecture

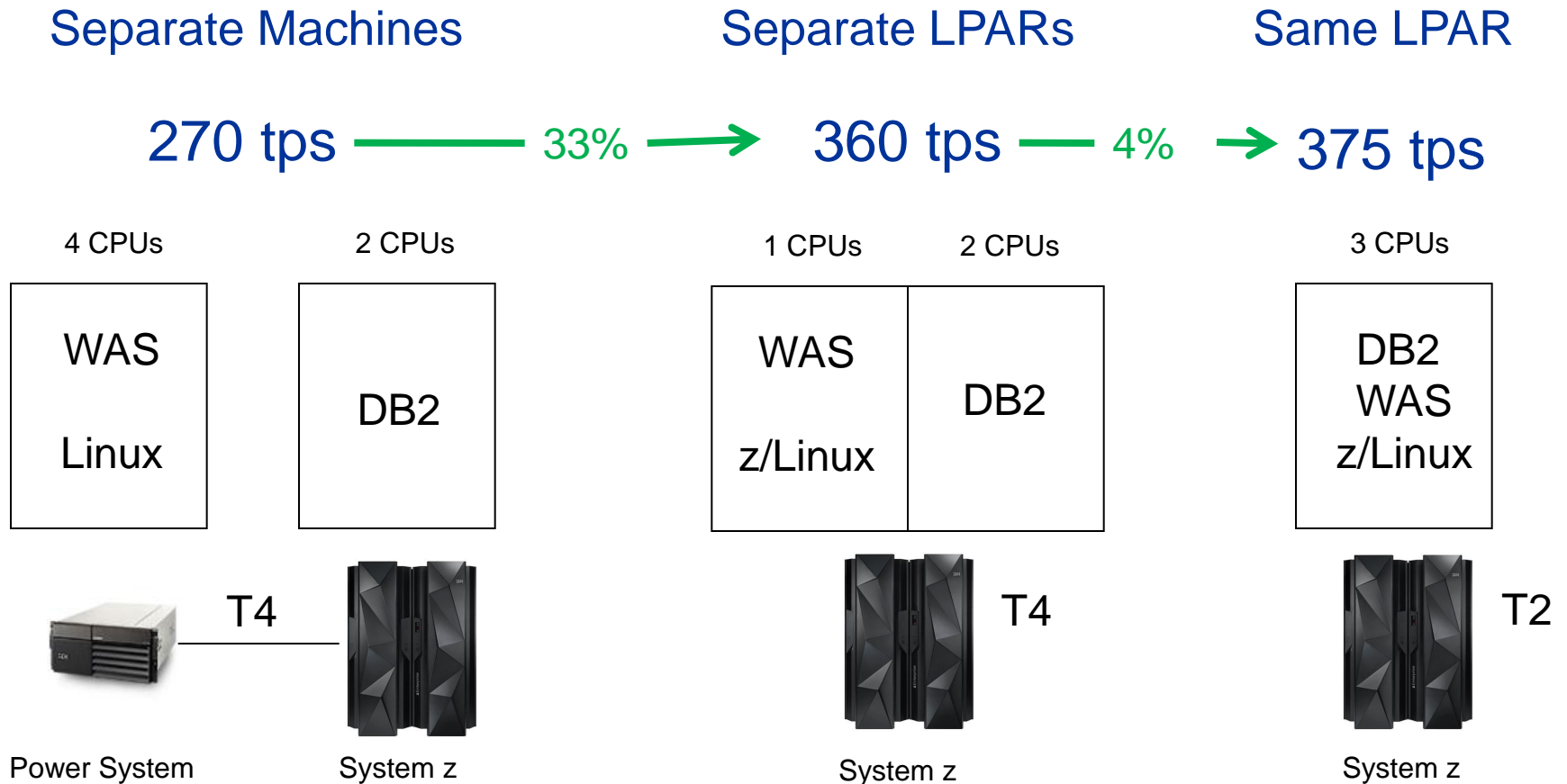

# SAP Applications Benefit From Co-location



## Business challenge:

Facing stiff competition from offshore manufacturers, Baldor needed to cut costs while simultaneously enhancing customer service with very rapid order processing, responsive manufacturing and swift delivery.

## Solution:

Migrated its mission-critical SAP and DB2-based applications to an IBM System z running Linux, z/OS and z/VM operating systems, eliminating several large Sun servers in the process.

## Benefits:

- Reduced IT costs as proportion of sales by 50%
- Consolidation cuts power by 40% and reduces data center floor space from 6,000 to 1,000 sq ft
- Cut system administration and maintenance costs

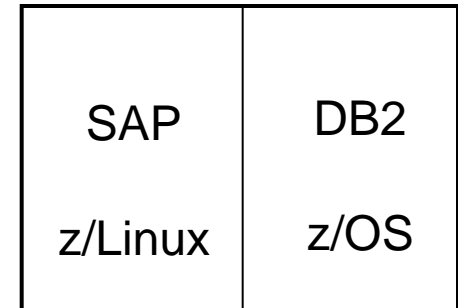

SAP Applications  
Co-located on System z

# Linux On z/VM Workloads Inherit System z Qualities Of Service

- Reliability, availability, serviceability characteristics of System z
- Capacity on demand upgrades
- Add physical processors to Linux environment without disruption
- Site failover for disaster recovery

# System z Capacity On Demand Provides Elasticity To Handle Unexpected Peaks

- Capacity on Demand
  - ▶ “Books” are shipped fully populated
  - ▶ Activate dormant processors as needed
  - ▶ Use for temporary or permanent capacity
  - ▶ Self-managed on/off
- New capacity is immediately available for work without service disruption

One Book with 36 Processors

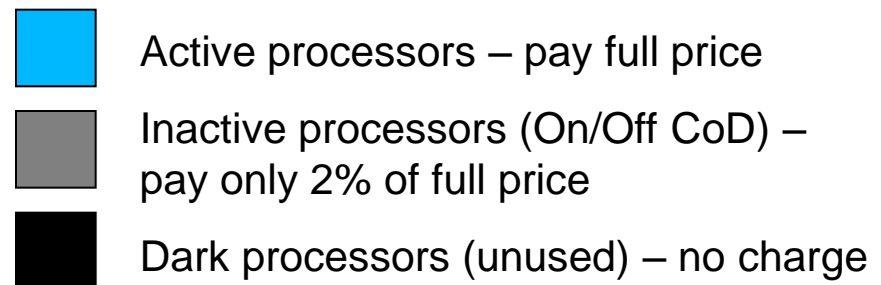
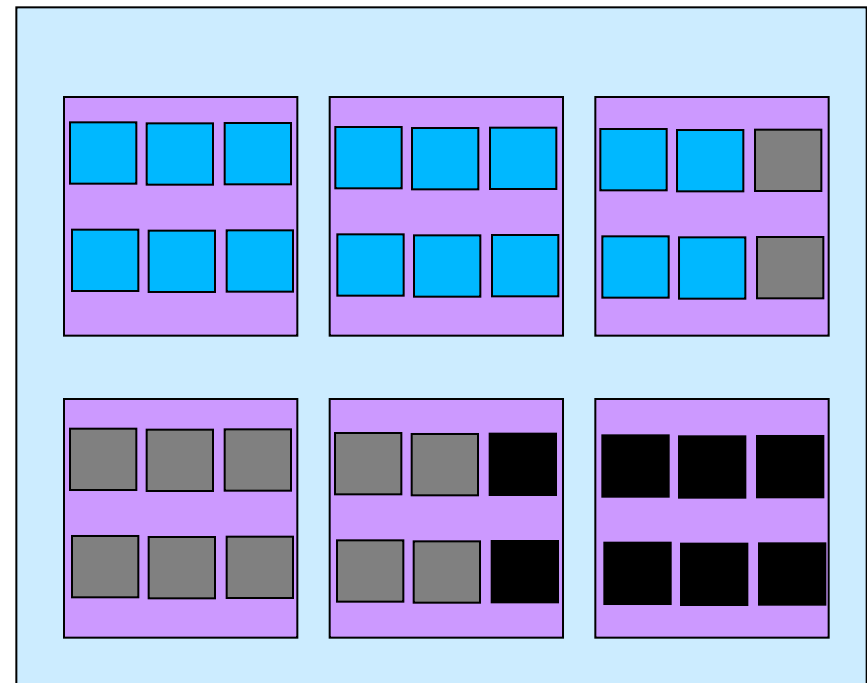

# DEMO: Dynamically Add New Processor To z/VM LPAR To Handle Increased Workload Without Disruption

1. A customer has in-house Risk Analysis program running on Linux on System z
2. Increased workload to all 4 Linux guests is causing z/VM LPAR utilization of 90%+
3. Customer determines this is a long term trend - additional physical capacity needed
4. New capacity made available to LPAR as new Logical CPU, available for work
  - ▶ Without disruption in service

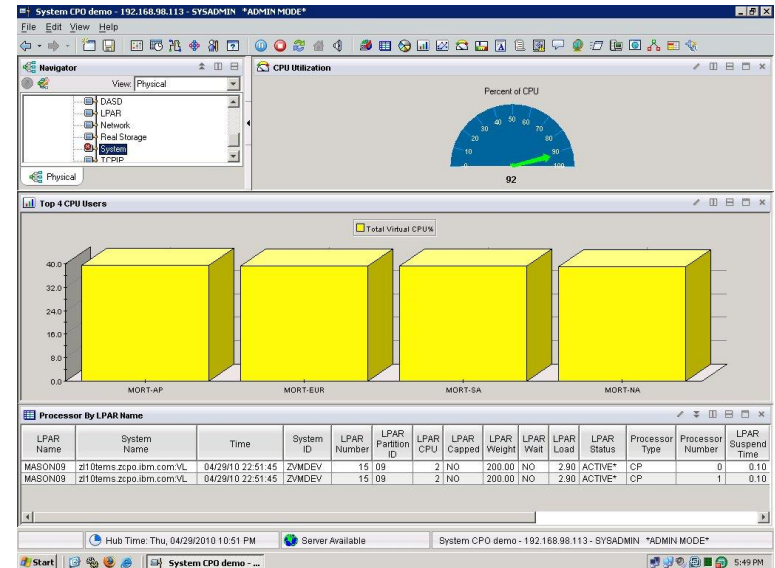

Note: Assumes available processors on installed books

# Cognos BI Workloads Benefit From High Reliability

*Which platform provides the lowest TCA over 3 years?*

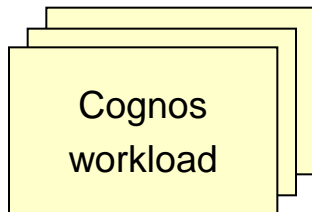

21 Cognos Report Workloads

Cognos 10 BI



21 HP DL580 Wintel servers  
(Xeon 2.13 GHz, 1ch/8co)  
168 cores total

**\$3.32M** (3 yr. TCA)



(Cognos runs as a zVM  
Linux on System z guest)

zEC12 with 2 IFLs

**\$0.40M** (3 yr. TCA)



zEC12

**88% lower cost!**

TCA includes hardware, software, maintenance, support and subscription. Software includes WebSphere and OS. Cognos 10 BI software cost is same for both environments since it is priced per authorized user and hence not included. Case study derived from a customer scenario in government industry.

# Transzap Benefits From High Reliability

## Business challenge:

Transzap offers its customers a comprehensive suite of financial software tools. As a small business with tens of billions of dollars in client transactions flowing through their systems each year, Transzap needed an economical, reliable platform to provide clients with high availability while enabling the capacity to accommodate growth within their software as a service business model.

## Solution:

Transzap decided to consolidate on an IBM System z platform to provide the stability and scalability needed to accommodate triple digit volume growth, enabling them to focus on the business of software innovation. Transzap migrated to System z and virtualized its critical applications on Linux on System z, a platform that supports Transzap's dynamic Java™ and Oracle environments.

## Benefits:

- Helps Transzap to serve more than 69,000 users across 6,800 companies
- Provides higher levels of uptime for their customers
- Offers peace of mind through 24x7 world-class hardware support

*“We intend to deliver a 99.9% application uptime guarantee to our customer base, thanks to the availability characteristics of System z.”*

*— Peter Flanagan, CEO of  
Transzap, Inc.*

## Solution components:

- IBM System z
- Linux on System z
- IBM z/VM



ZSP03141-USEN-00



# Cloud Technologies For zEnterprise

Now let's focus on labor costs and agility!



**Reduce Hardware,  
Software, and Labor  
Costs**

Consolidation &  
Virtualization

**Reduce Labor Costs  
Improve Agility**

Automation

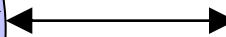

# A High-Level View Of The Labor Model

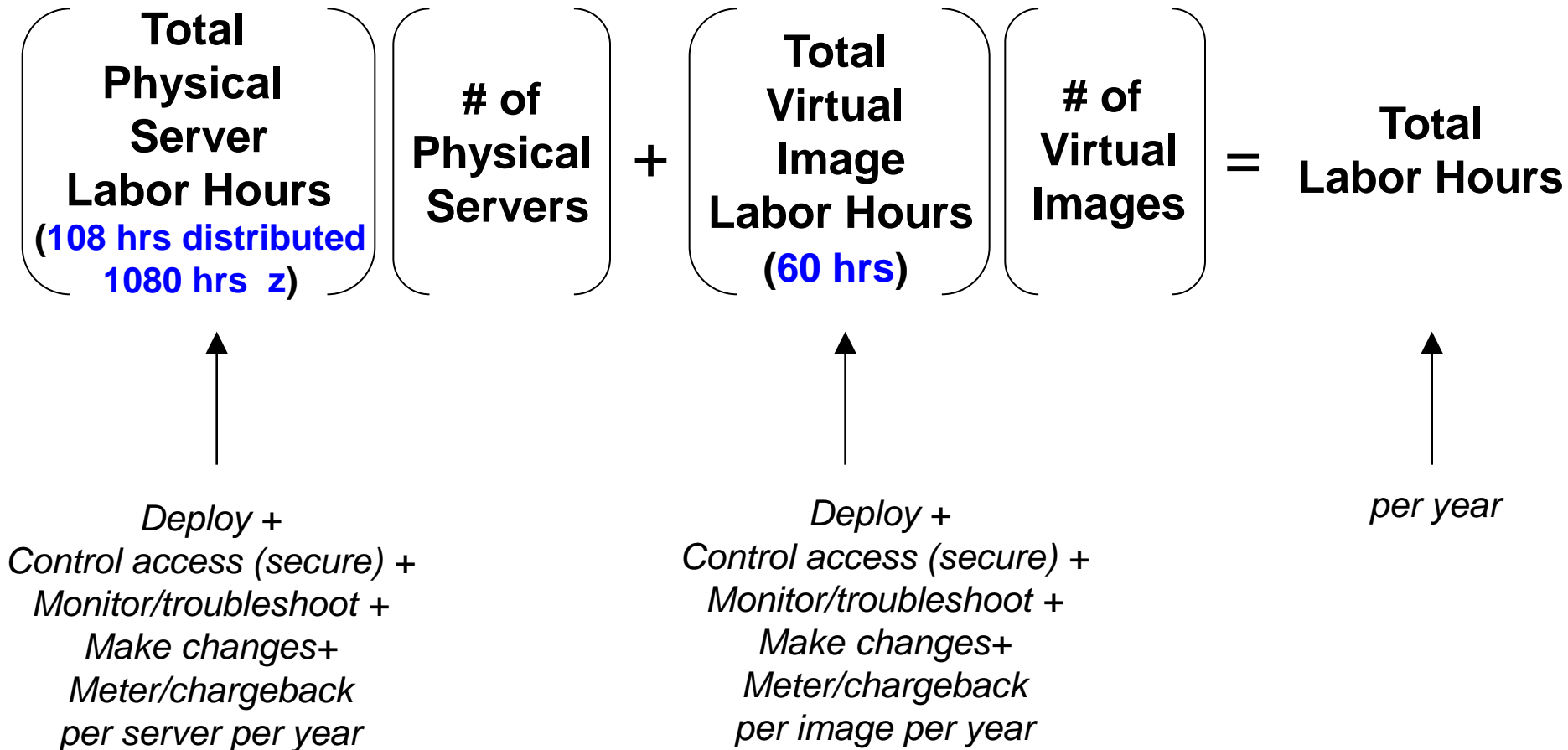

Note: labor model best fitted to field data

# A High-Level View Of The Labor Model

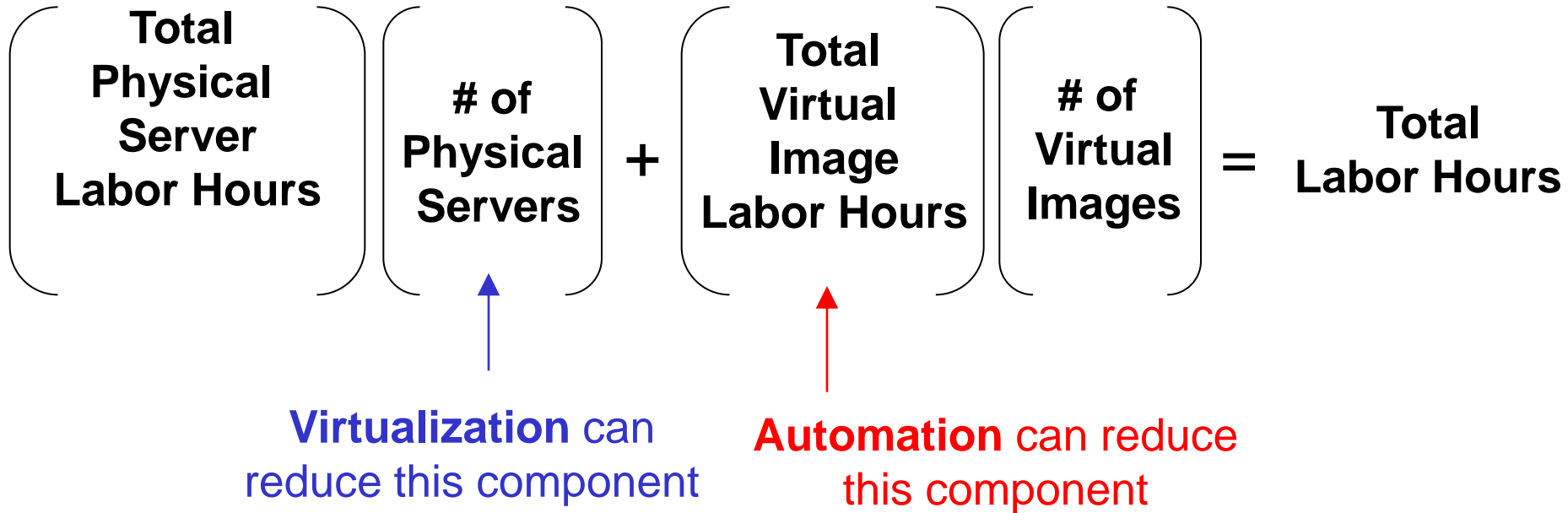

# Which Option Requires The Least Amount Of Labor?

*Which platform provides the lowest labor costs over 3 years?*

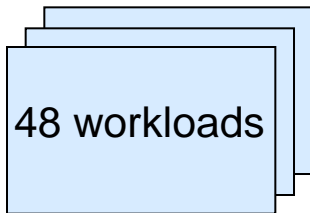

Online banking workloads, each driving **22** transactions per second, with **1 MB I/O per transaction**

48 Sun Fire X4170  
M2



1  
z/VM on zEC12  
32 IFLs



# Consolidation And Virtualization On System z Can Reduce Labor Costs

## Case Study With 48 Workloads

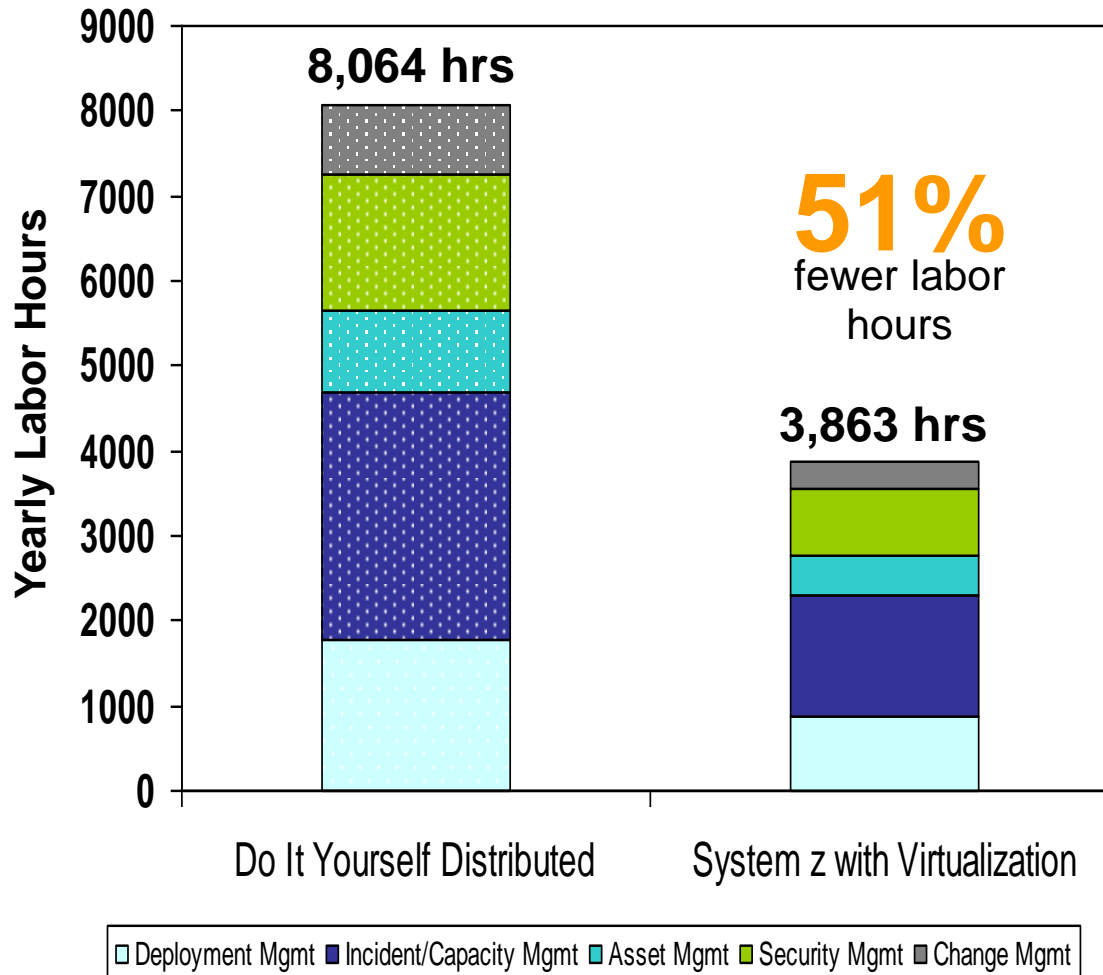

# Automation With IBM SmartCloud Provisioning For Virtual Cloud Environments

- Self-service automated provisioning of virtual systems and application into a pool/cloud of external virtualized hardware running a supported hypervisor
  - ▶ “Bring your own cloud”
  - ▶ Supports various hypervisors, including, zVM, PowerVM, VMware ESX
- Standardized IBM middleware virtual images and patterns

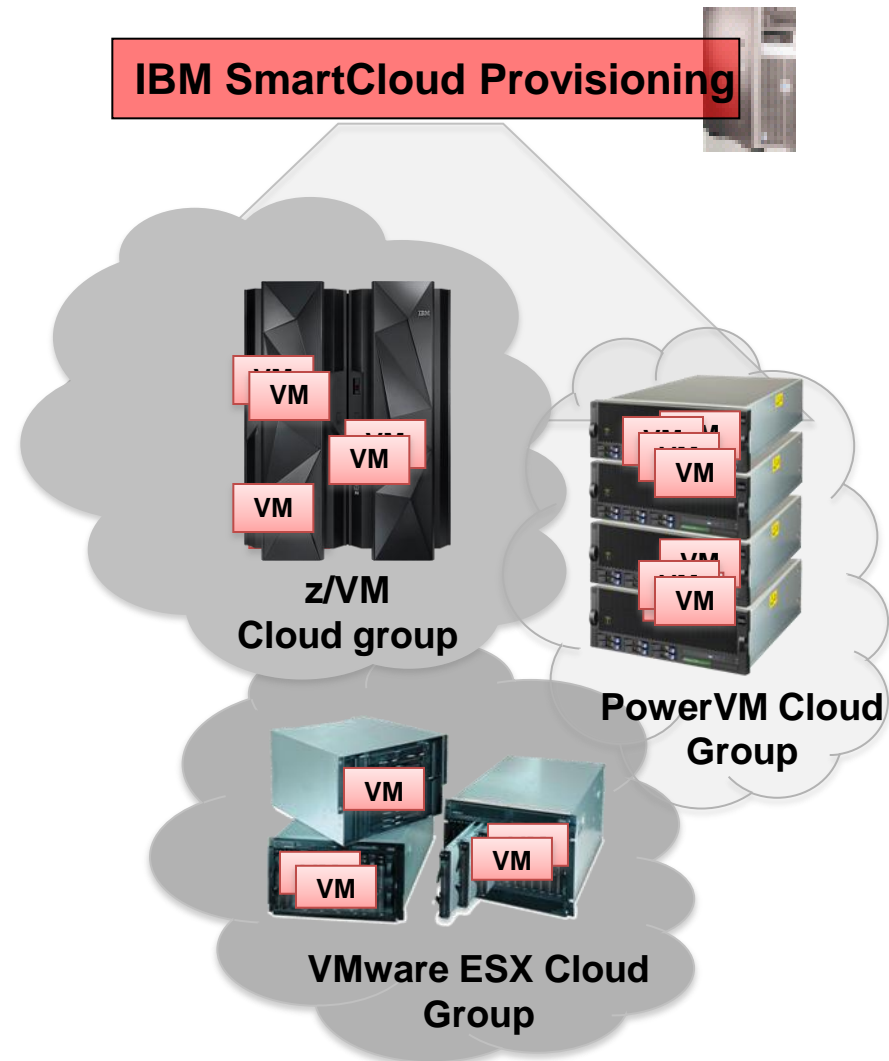

# Automation With IBM SmartCloud Provisioning Can Further Reduce Costs



User selects and deploys a pattern

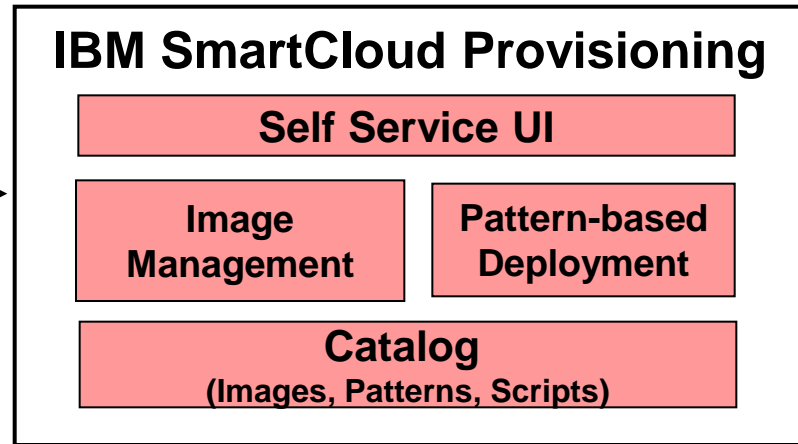

- Self-service console for users
- Virtual images and patterns for quick-starts
- Drag and drop tooling for creating and deploying virtual applications using images and patterns
- Intelligent placement algorithm optimize resource utilization based on cloud activity

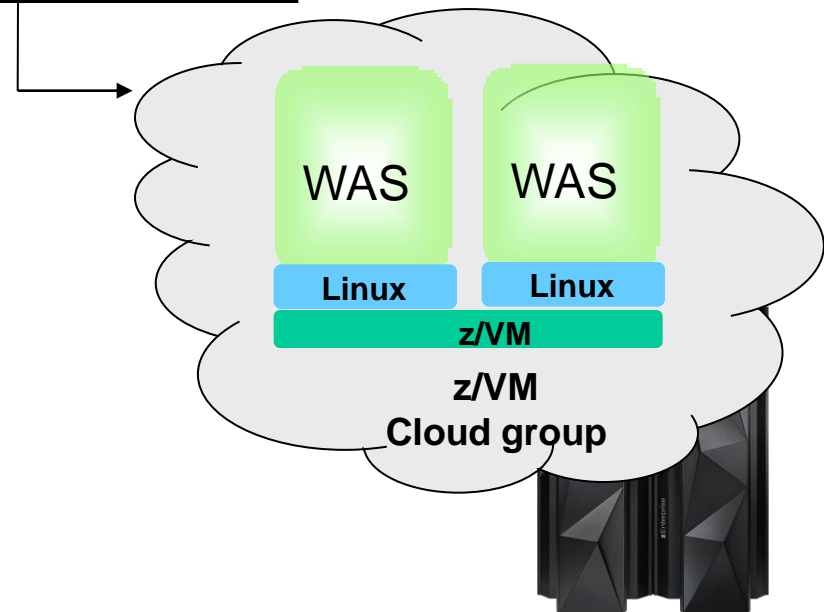

# IBM SmartCloud Provisioning Make It Easier To Get Started With New Virtualized Images

- IBM Middleware shipped as an Hypervisor Editions (.OVF virtual images), ready to run on a hypervisor
- Hypervisor Editions offered for z/VM include:
  - ▶ WebSphere Application Server
  - ▶ WebSphere Process Server
  - ▶ WebSphere Portal Server
- Maintenance, support, and fixes through IBM for both middleware and operating system
  - ▶ New images include most recent GA components of IBM middleware, as well as OS patches

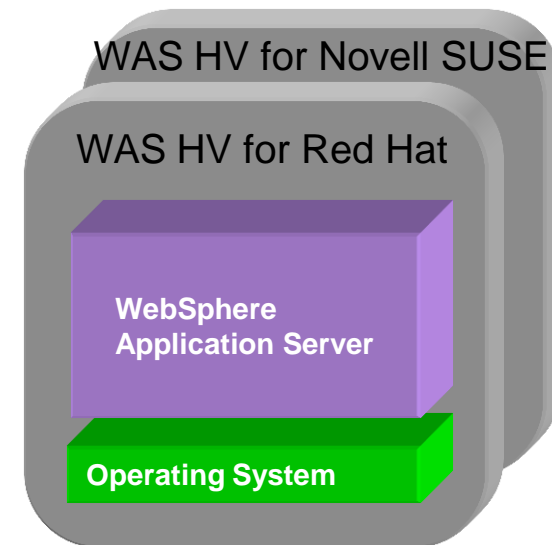



# IBM SmartCloud Provisioning Deploys Standardized Virtual System Patterns

A Virtual System Pattern is one or more virtual images and script packages to satisfy a certain deployment topology

Single Server

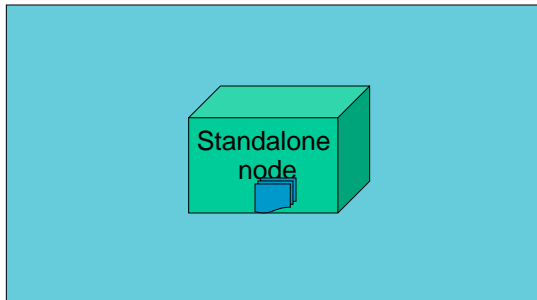

WebSphere cluster

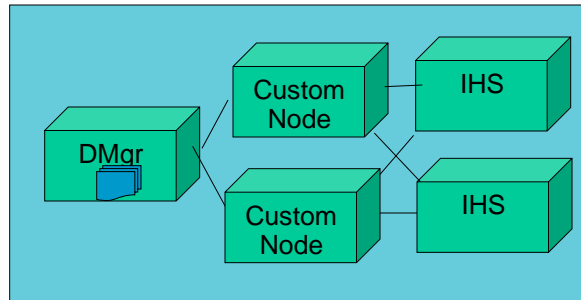

WebSphere Advanced Cluster

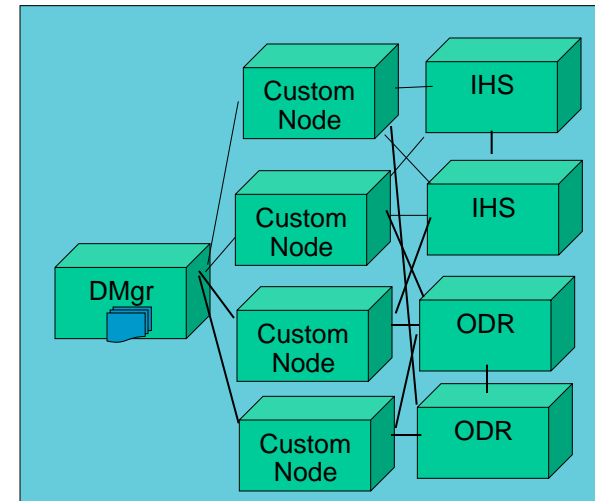

WebSphere cluster (dev)

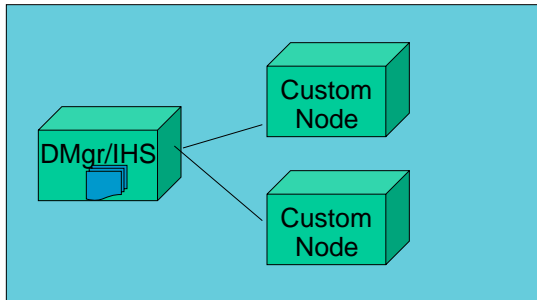

WebSphere Process Server (Scalable)

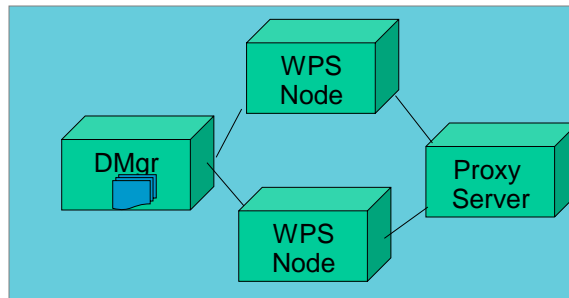

DMgr = Deployment Manager

IHS = IBM http Server

# Example Of How It Works - Use Pattern For Automated Deployment Of Single WAS Server

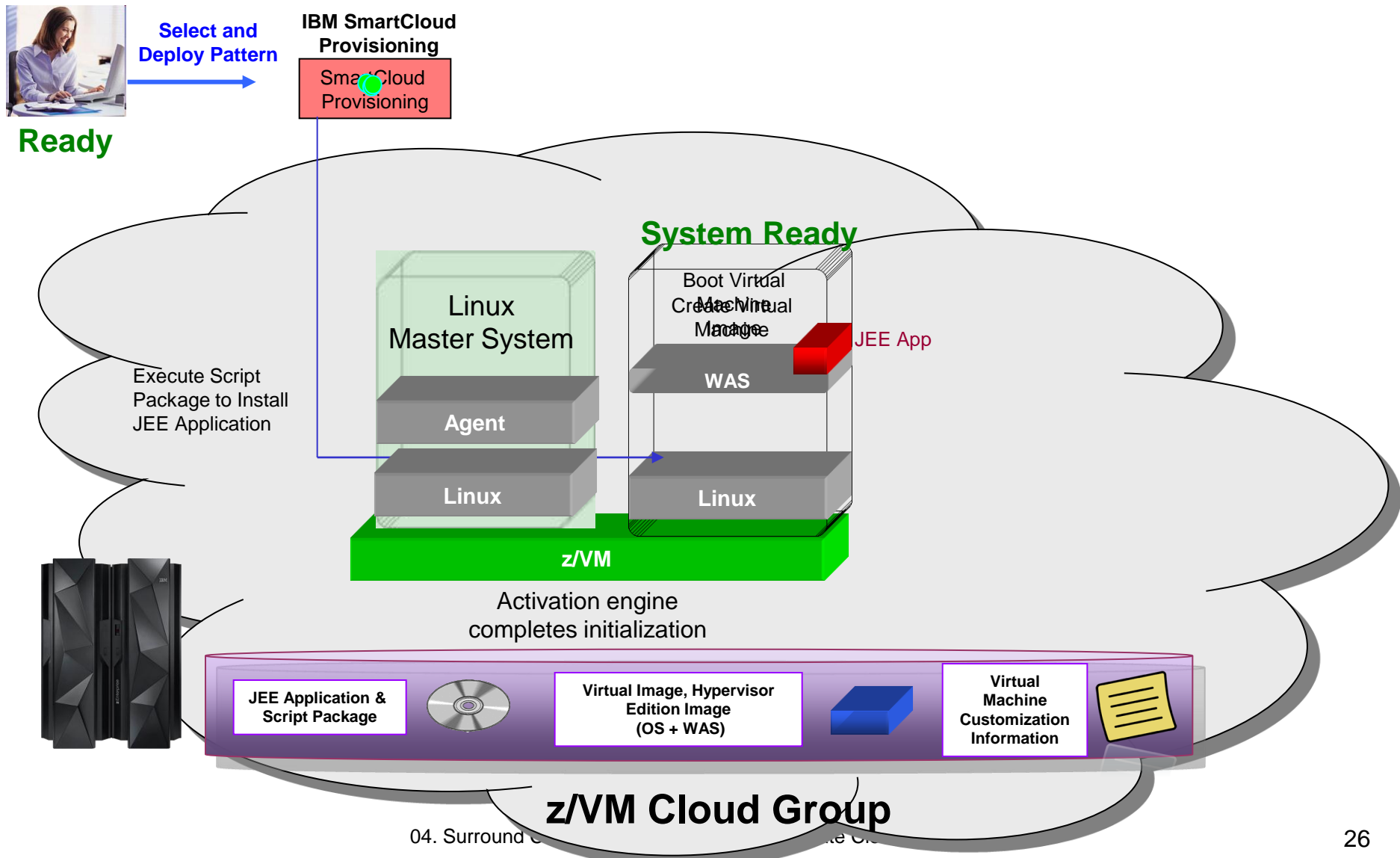

# Example: Normal Deployment Steps For WAS High Available Clustered Environment

1. Involves creating 4 virtual servers
  - ▶ 1 WebSphere deployment manager
  - ▶ 2 WebSphere Node
  - ▶ 1 IBM HTTP Server
2. Install the WAS Update Installer and install the required iFixs
3. Create WebSphere Cluster with 2 members
4. Configure the HTTP Server
5. Configure Session replication on servers to support Failover
6. Deploy the Application to the WebSphere Cluster

WebSphere cluster

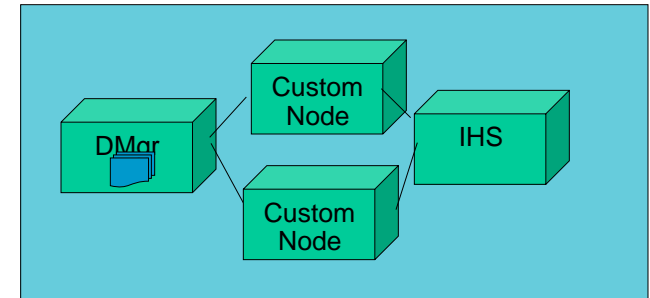

***All of these steps are done automatically with IBM SmartCloud Provisioning***

# DEMO: Fast Deployment Of WAS Cluster With IBM SmartCloud Provisioning

- Self-service console for user
- Pre-loaded Websphere best practices patterns for quick-starts
- Drag and drop tooling to provision a cluster of WAS-based web application

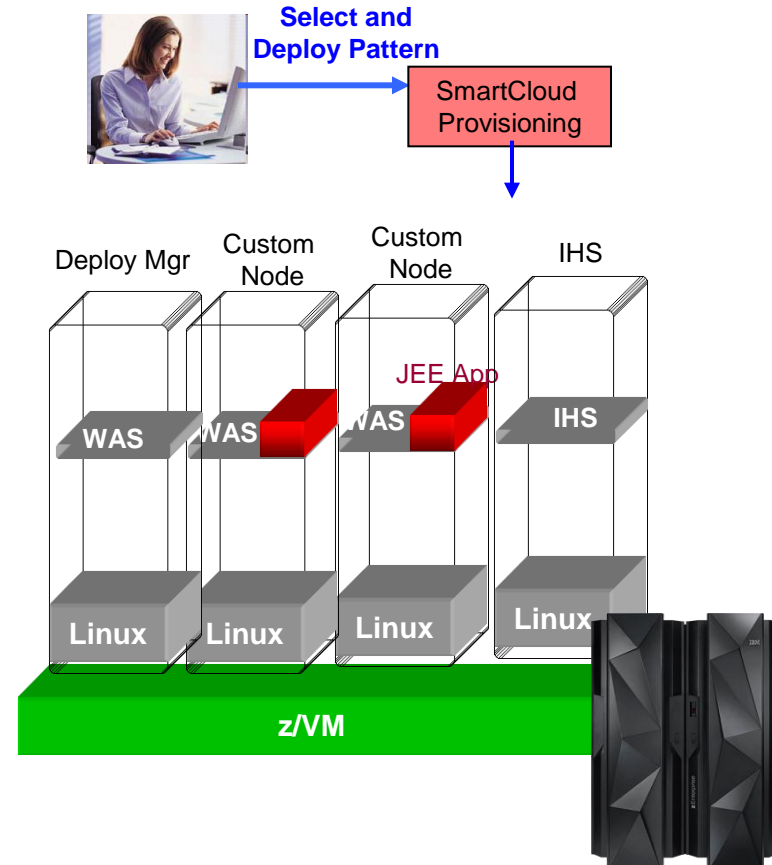

# IBM SmartCloud Provisioning Automated Pattern-Based Deployment Is Fast

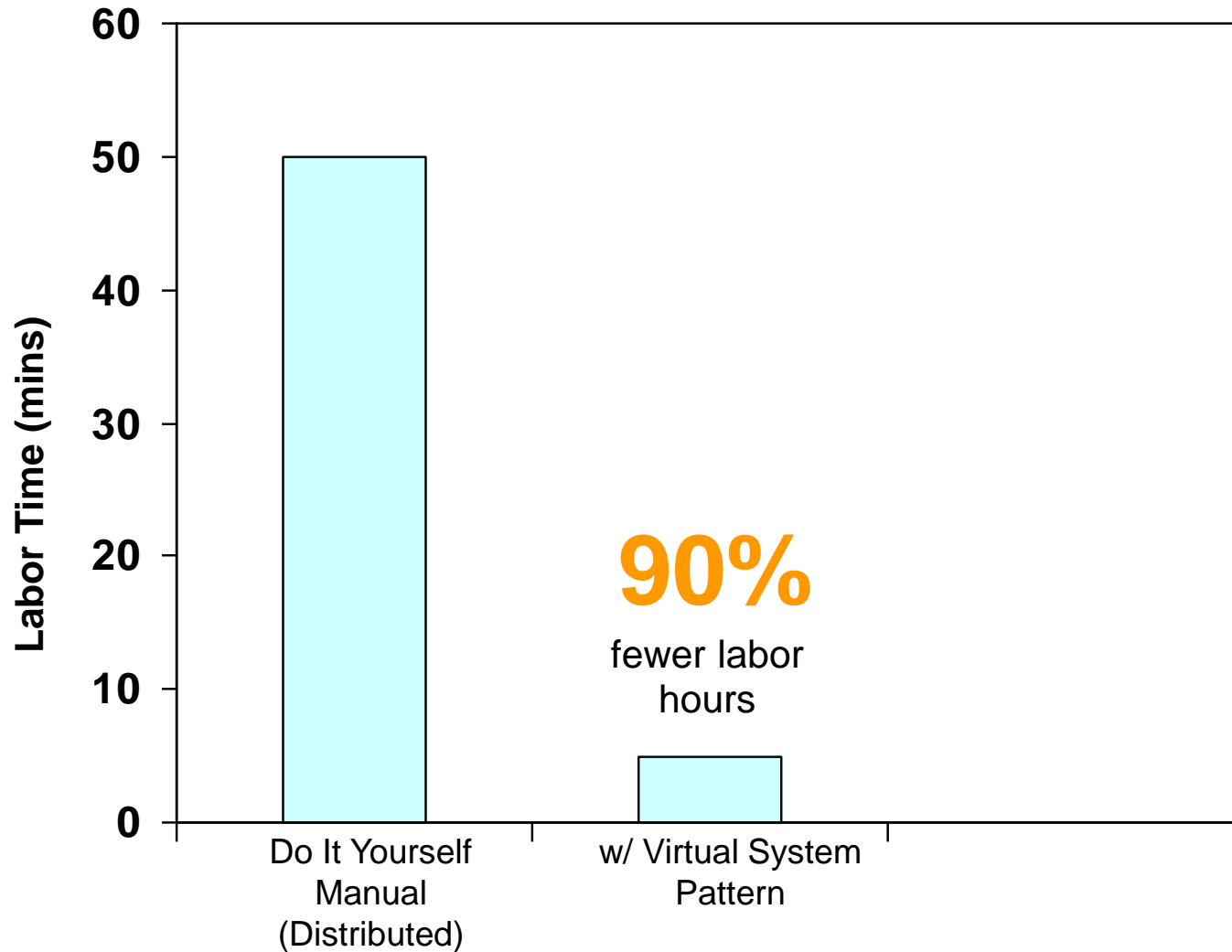

Workload Deployed

# IBM SmartCloud Provisioning Can Lower Labor Costs Further

## Example With 48 Workloads

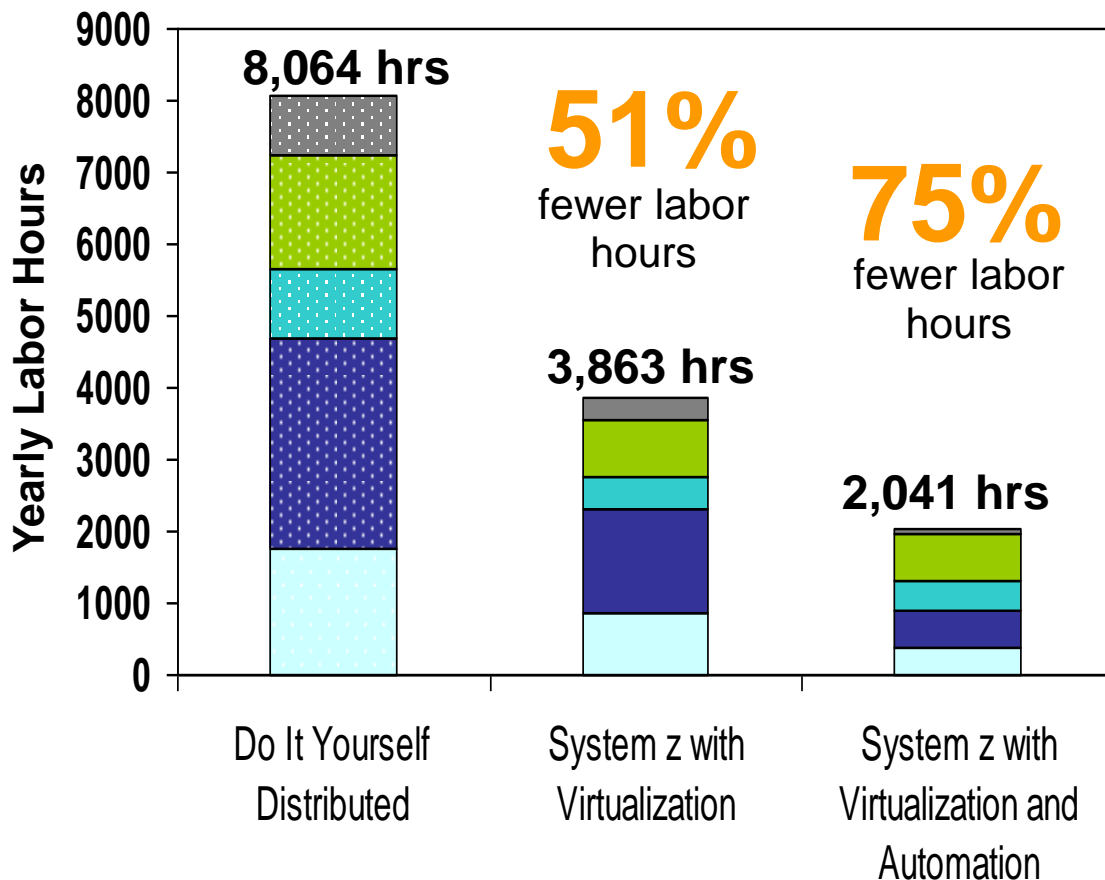

## SmartCloud Provisioning Contributors to Labor Savings

- **Deployment**
  - ▶ *Fast pattern-based deployment*
- **Incident/capacity**
  - ▶ *Centrally monitor and resolve issues*
- **Asset**
  - ▶ *Track license usage of products*
- **Security**
  - ▶ *Centralized access control*
- **Change**
  - ▶ *Visibility into relationships of virtual images in a workload*
  - ▶ *Automatically apply changes to desired virtual servers*

Deployment Mgmt Incident/Capacity Mgmt Asset Mgmt Security Mgmt Change Mgmt

# Summary: System z Can Lower Total Acquisition and Labor Costs

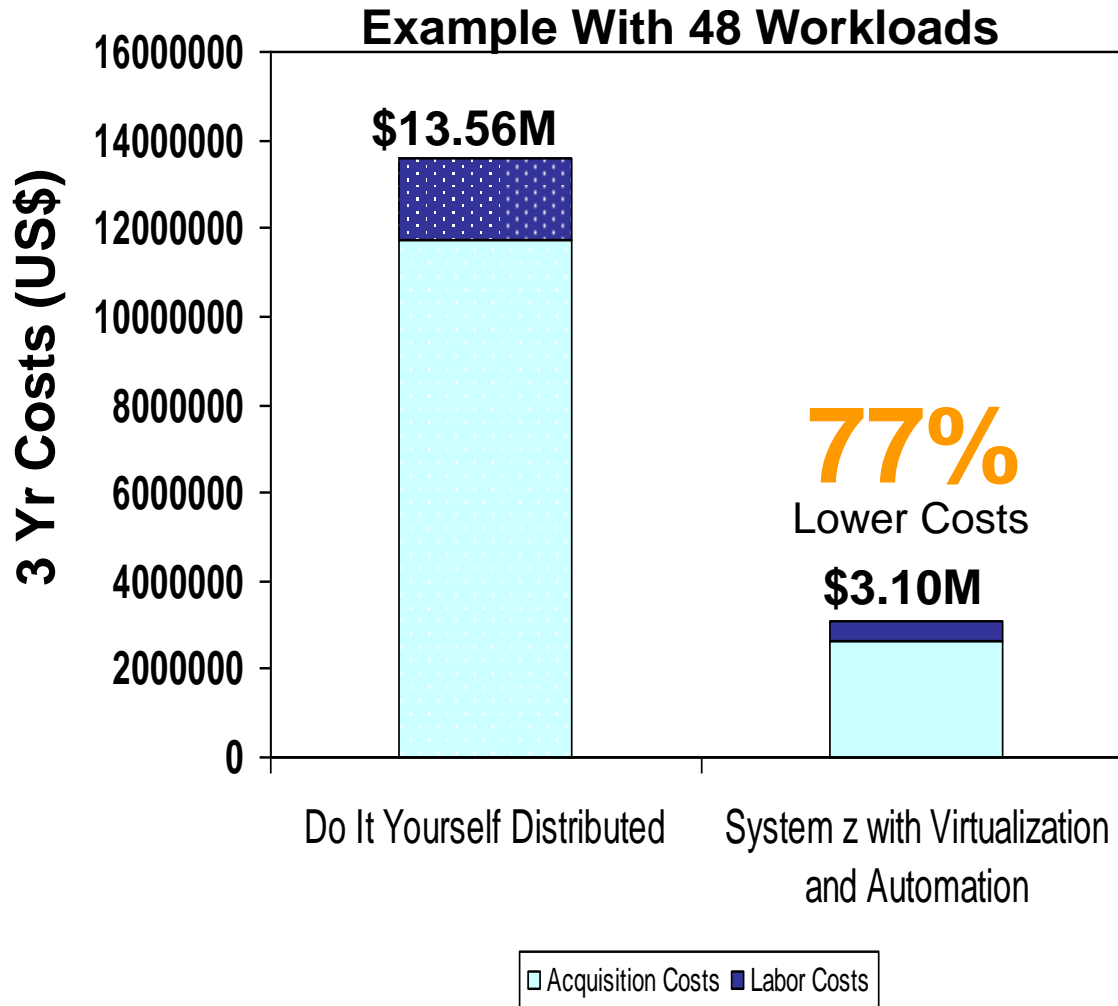

Note: 3 year TCO includes hardware acquisition, maintenance, software acquisition, S&S and labor. US pricing and will vary by country.

# Summary

Take out costs and be more agile  
with cloud technologies on System z!



**IBM**





THANK YOU

# Notice Regarding Specialty Engines (e.g., zIIPs, zAAPs and IFLs):

Any information contained in this document regarding Specialty Engines ("SEs") and SE eligible workloads provides only general descriptions of the types and portions of workloads that are eligible for execution on Specialty Engines (e.g., zIIPs, zAAPs, and IFLs). IBM authorizes customers to use IBM SE only to execute the processing of Eligible Workloads of specific Programs expressly authorized by IBM as specified in the "Authorized Use Table for IBM Machines" provided at

[www.ibm.com/systems/support/machine\\_warranties/machine\\_code/aut.html](http://www.ibm.com/systems/support/machine_warranties/machine_code/aut.html) ("AUT").

No other workload processing is authorized for execution on an SE.

IBM offers SEs at a lower price than General Processors/Central Processors because customers are authorized to use SEs only to process certain types and/or amounts of workloads as specified by IBM in the AUT.