

DB2 for z/OS Trends and Directions

Jeff Josten, IBM Distinguished Engineer, DB2 Architect

Tom Ramey, Director, DB2 for z/OS



Agenda

- **DB2 Strategy**
- **DB2 11 adoption rate and quality**

- **DB2 11 overview, and some DB2 10 news**
- **z Systems synergy**
- **DB2 Cypress preview**



Please Note

- IBM's statements regarding its plans, directions, and intent are subject to change or withdrawal without notice at IBM's sole discretion.
- Information regarding potential future products is intended to outline our general product direction and it should not be relied on in making a purchasing decision.
- The information mentioned regarding potential future products is not a commitment, promise, or legal obligation to deliver any material, code or functionality. Information about potential future products may not be incorporated into any contract.
- The development, release, and timing of any future features or functionality described for our products remains at our sole discretion.

Performance is based on measurements and projections using standard IBM benchmarks in a controlled environment. The actual throughput or performance that any user will experience will vary depending upon many factors, including considerations such as the amount of multiprogramming in the user's job stream, the I/O configuration, the storage configuration, and the workload processed. Therefore, no assurance can be given that an individual user will achieve results similar to those stated here.

The new imperatives for digital business

Availability

24x7x365
application
availability

Response Time

Users expect
<1 second
app utility

Personalization

80%
of Marketers send
the same content to
all subscribers

Trust

70%
lack confidence in
data security

Integration

91%
of new customer-facing
apps access the
mainframe

Scale

35%
mobile transaction
growth annually

IBM z Systems: built for the digital era



The foundation for **Mobile** and **Social** engagement

The ultimate **Analytics** engine for right-time insight

Superior service at lower cost through **Cloud**

A robust and **Trusted** infrastructure

IBM z13: The New Possible



Mobile

Deliver **up to 36%** better response time, **up to 61%** better throughput, and **up to 17%** lower cost per mobile transaction



Analytics

Deliver insights **up to 17x** faster and with **13x** better price performance than closest competitor



Cloud

Enable superior Cloud services at **up to 40%** lower cost than x86 Cloud and **up to 65%** less than Public Cloud over three years



Security

Accelerate speed of encryption **up to 2x** over the zEC12 to help protect the privacy of data throughout its life cycle

Extend the core

reliability:availability:scalability:security

Extend the unique value of System z

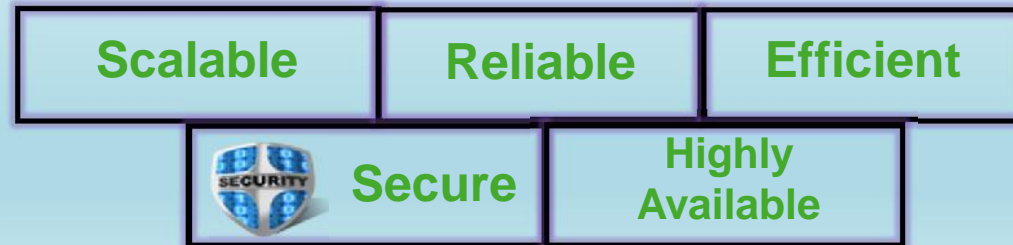

Empower the future

analytics:autonomics:cloud:mobile

Empower the next wave of applications



Cloud
Self provisioning, Multi-tenancy, Self managing, guaranteed SLAs



Analytics
Real time analytics integrated with OLTP



Mobile
Agile development, Enterprise mobile scale

Extend the core

reliability:availability:scalability:security

- Parallel Sysplex and DB2 Data Sharing
- Availability and scalability leadership
- Multi-site DR and continuous availability
- Reliability, quality, and Security Leadership
- System z hw/sw integration
- High Performance
- In-Memory Database



Empower the future

analytics:autonomics:cloud:mobile

- Support the next wave of applications
- Analytics and HTAP
- Mobile and Internet of Things (IoT)
- Cloud and developer self-service
- DevOps: Continuous delivery
- Simplification and Autonomics



Why Mobile on System z?

Because mobile users want ...

INSTANT RESPONSE

*Fastest response time, **real-time** access to System of Record, current data - not old copy. **Acceleration of queries 2000x** to meet mobile demands*

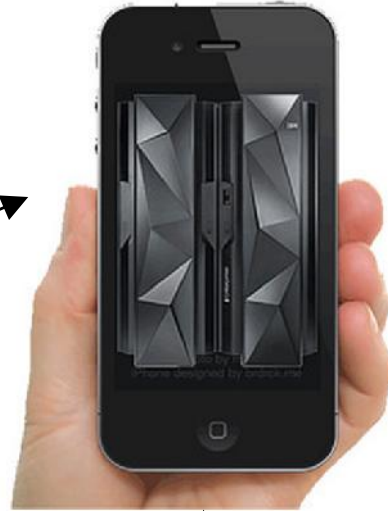

Highest SCALABILITY on the planet

*Only IBM System z can handle the **massive spikes** and growth of mobile workloads*

Toughest DATA SECURITY and RESILIENCE

*Modern **agile tooling** with pervasive best-of-breed **security, scalability, RAS***

*Mobile data is growing at **61% CAGR 2013-2018***

Cloud is the infrastructure model of the digital era

System z enables a choice of delivery models



Private Cloud

z/OS and Linux on System z as the foundation of the most secure, scalable private cloud infrastructure

Hybrid Cloud

Leveraging BlueMix and interoperability with SoftLayer, AWS and other public cloud offerings

Public Cloud

Enabling MSPs/CSPs to deliver differentiated mainframe-based service offerings



Cloud/Mobile integration with DB2 - simple and secure

z/OS Connect

Getting REST and JSON into your mainframe environment in a way that enables you to best take advantage of the assets that exist there:

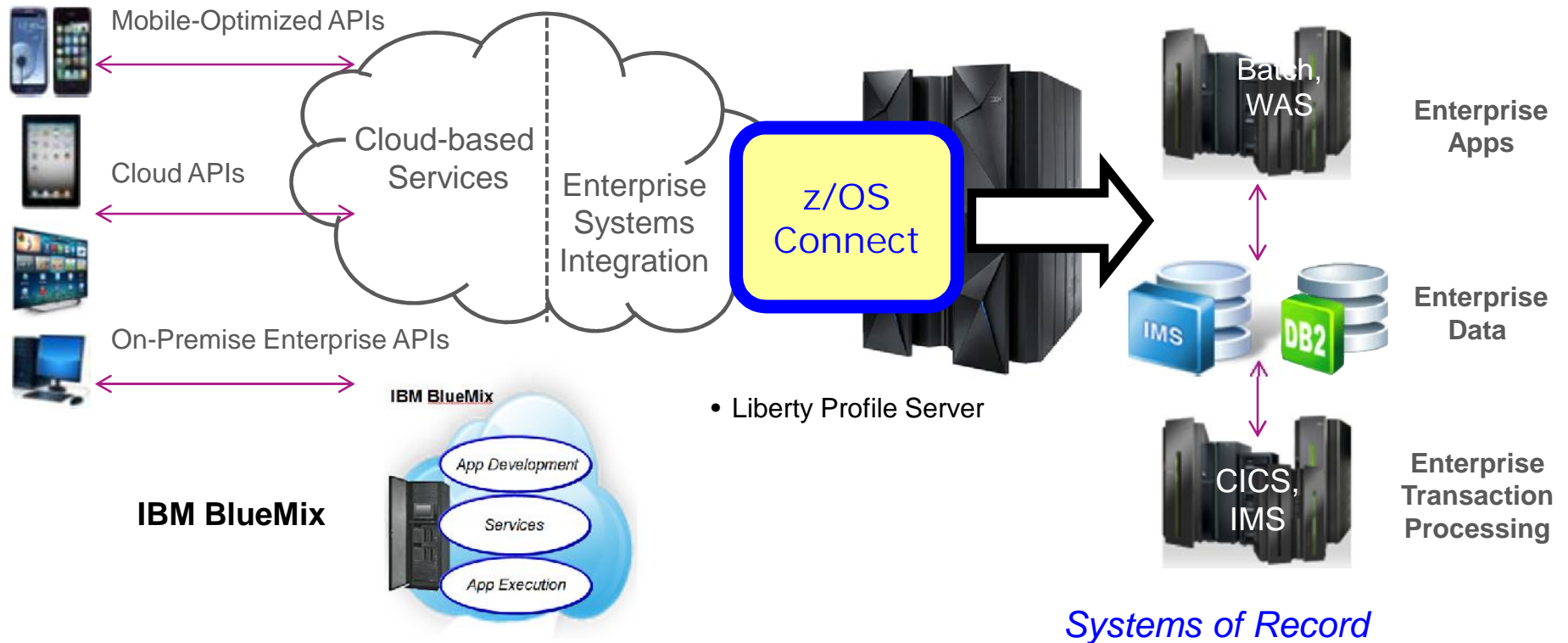

Provides a common and consistent entry point for mobile access to one or many backend systems

Simplifies front-end functions by allowing them to pass RESTful and JSON rather than be aware of or involved in data transformation

Enabling Next Generation cloud apps

**Build hybrid environments.
Connect to on-premises systems
of record plus other public and
private clouds. Expose your own
APIs to your developers.**

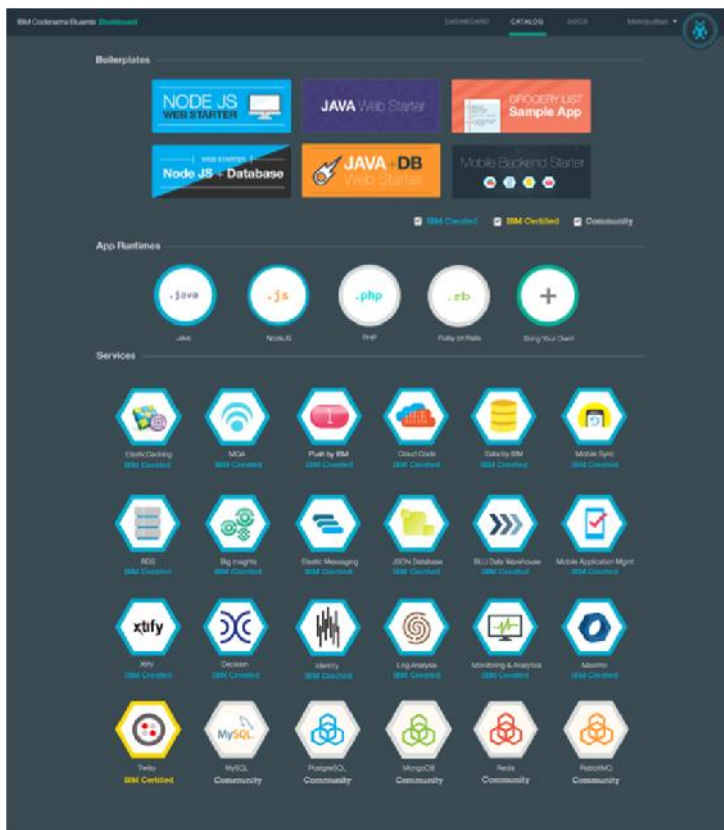

BlueMix brings unparalleled speed to development, deployment and IT operations & cuts the time needed to go from idea to running application to days vs months

100% Open Standards-based scalable platform – a competitive differentiation

Allows customers to use proven API services that they use on-premises, but in a much simplified, easy to consumer and instantly deployed manner

System z - BlueMix Integration

- Expose services in a secure manner via zOS Connect to achieve rapid open source based development whilst leveraging mainframe assets
- Expose z/OS Data as-a-Service via BlueMix to enable system of record to be called by Dev-Ops driven composable apps

Vision of database cloud services

Simplification & Cost reduction



- Get databases on z/OS as easy as a server on the amazon cloud
 - In minutes instead of days
- Simply the management of the entire lifecycle including
 - Provisioning
 - Maintenance
 - Cloning / Copy
 - Release Migration
- Enforce standardization through automation
- Switch to self-service type of operation (opposite of admin driven as of today)



Benefits

- Drive down expenses
- Improve user experience
- Increase quality of service
- History of lifecycle operations (audit)

What some DB2 customers doing with Cloud, Mobile and Internet Of Things

Growing business and customer satisfaction



Location-based promotions

- Find the nearest restaurant, hotel, or business
- Customer specific discounts based past purchase history

Optimize machines, logistics, customer usage

- Capture/track equipment location, movement and usage
 - Higher productivity and uptime
 - Better manage logistics and communication across fleet
 - Easy customer dashboard to access machinery and usage data
- Geo fencing keeps equipment on site and on hand



Simplify tax collection

- Tablet-based tax collection using GPS location
- Improved tax collection rate

Tracking and billing every text/call/download – Billions per second

Analytics on z: Data is the newest resource for competitive advantage

7.6%

boost

to customer lifetime
value for firms using
engagement analytics

\$13

for every dollar
spent

estimate of analytics
payback; 1.2 X more
than 3 years ago

\$226

billion

estimated fraud
loss to healthcare
every year

Source: Aberdeen Group

Challenges with traditional analytics processing

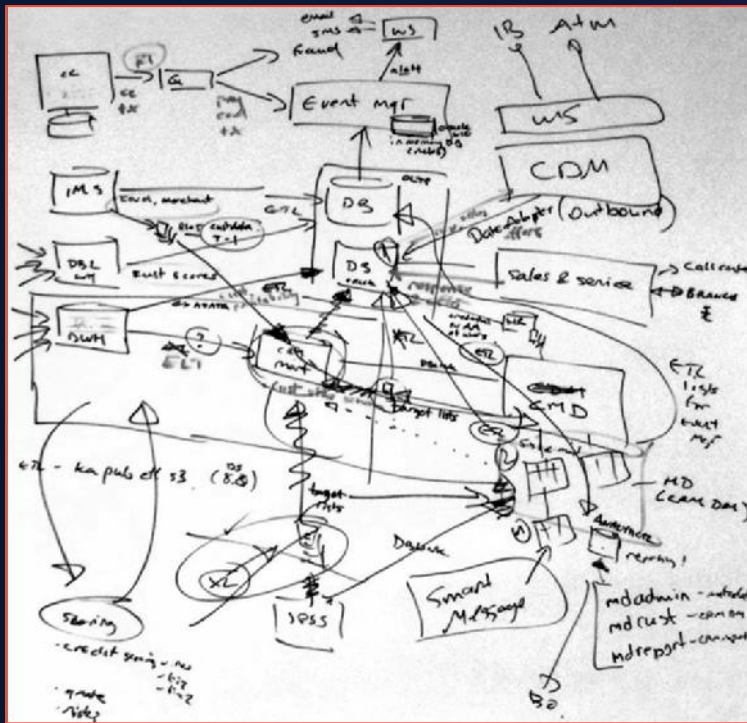

80% of the world's operational data resides on System z

Significant complexity

Data is move from operational databases to separated data warehouses/data marts to support analytics

Analytics latency

Transactional data is not readily or easily available for analytics when created

Lack of synchronization

Data is not easily aggregated and users are not assured they have access to “fresh” data. Logistics are difficult.

Data duplication

Multiple copies of the same data is proliferated throughout the organization. Security exposure is magnified.

Excessive costs

An IT infrastructure that was not designed nor can support real-time analytics

Moving data off of z Systems is costly

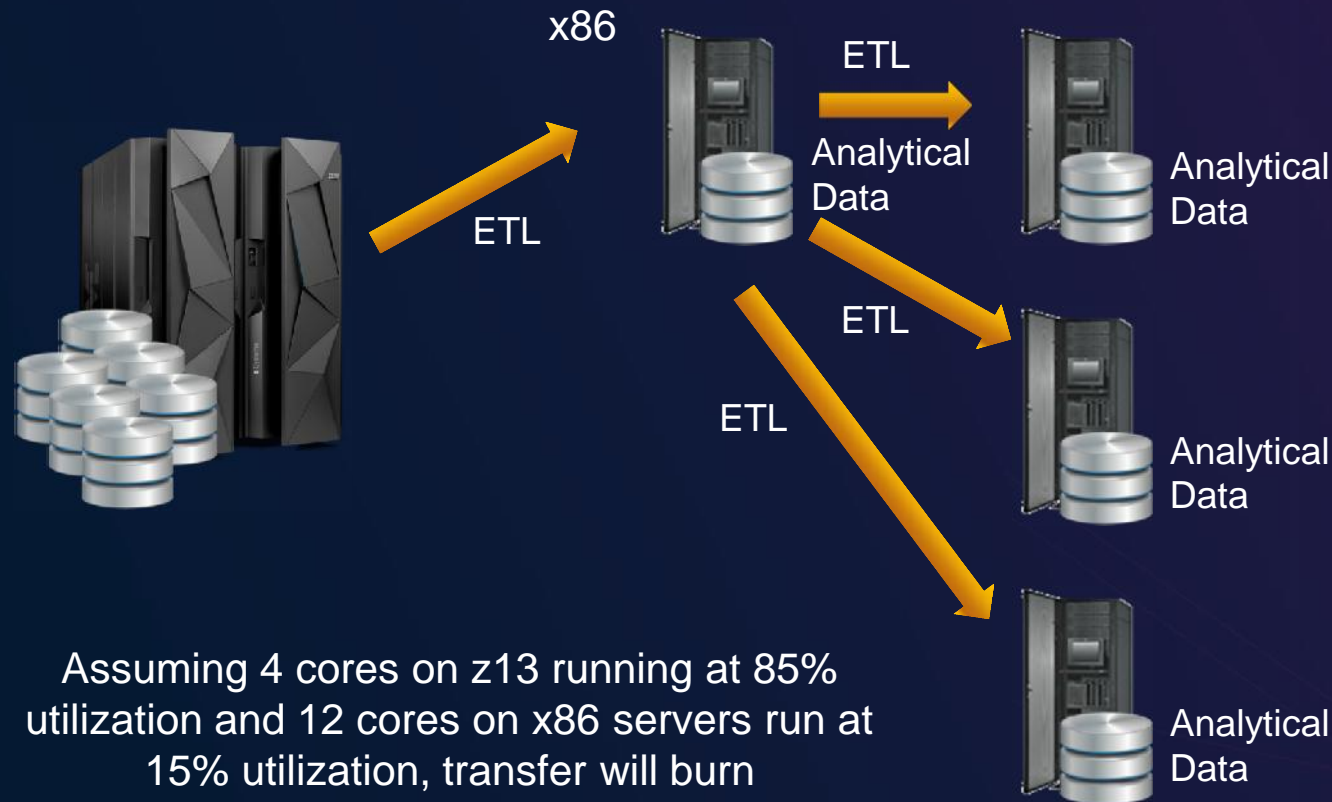

Assuming 4 cores on z13 running at 85% utilization and 12 cores on x86 servers run at 15% utilization, transfer will burn

519 MIPS and use **30 x86 cores** *per day*

To move 1TB of data daily off z Systems can cost over \$10M over 4 years

Estimated 4 year cost summary

System costs =
\$9,864,412

Labor costs =
\$393,927

Total =
\$10,258,339

Some clients report using 30% - 40% of System z cycles to move data

... So a new deployment strategy is needed

Bring the analytics to
where the data and
transactions originate
for greatest value

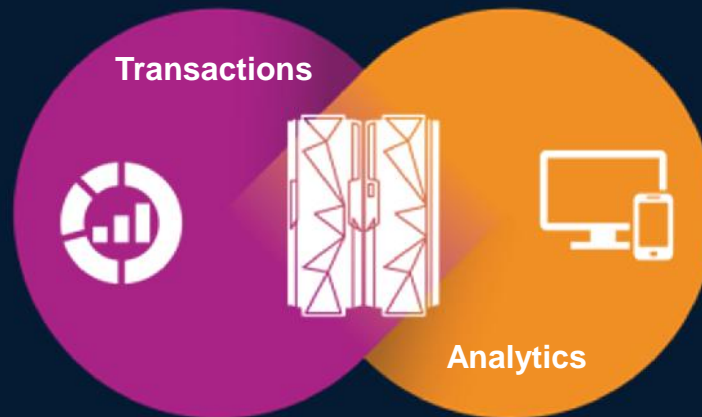

Insights on every transaction

- Deliver real-time insights at the point of impact
- Manage data lifecycle and governance
- Eliminate redundancy and avoid ETL

72%

say greatest value will come from analyzing transactional data

55%

of enterprise applications need mainframe to complete transactions

z Analytics Delivers the Breadth of Capabilities

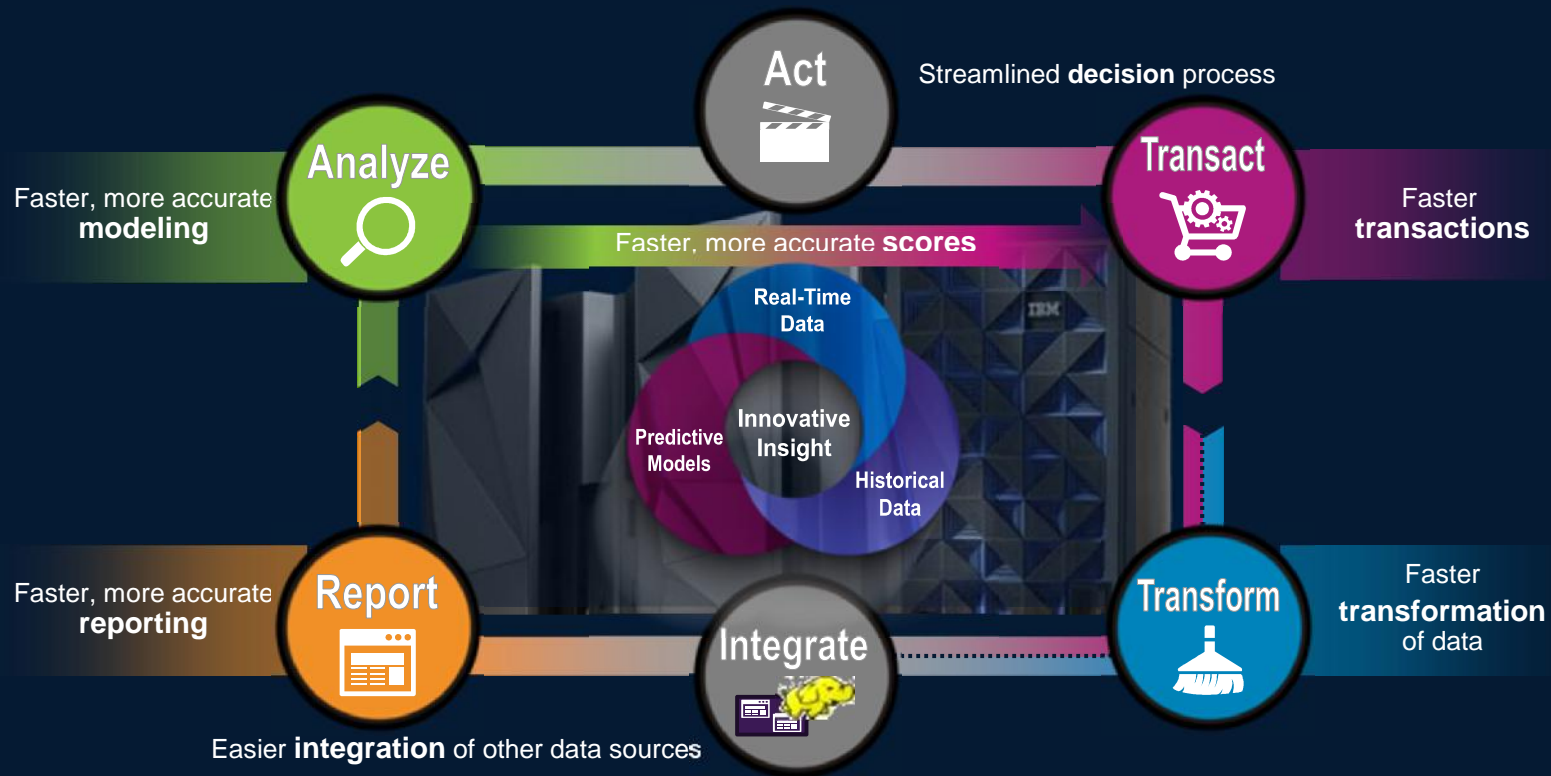

Integrated operations and analytics

Hybrid transactional/analytical processing

Robust operational throughput/ITR
20.5 million trx per hour

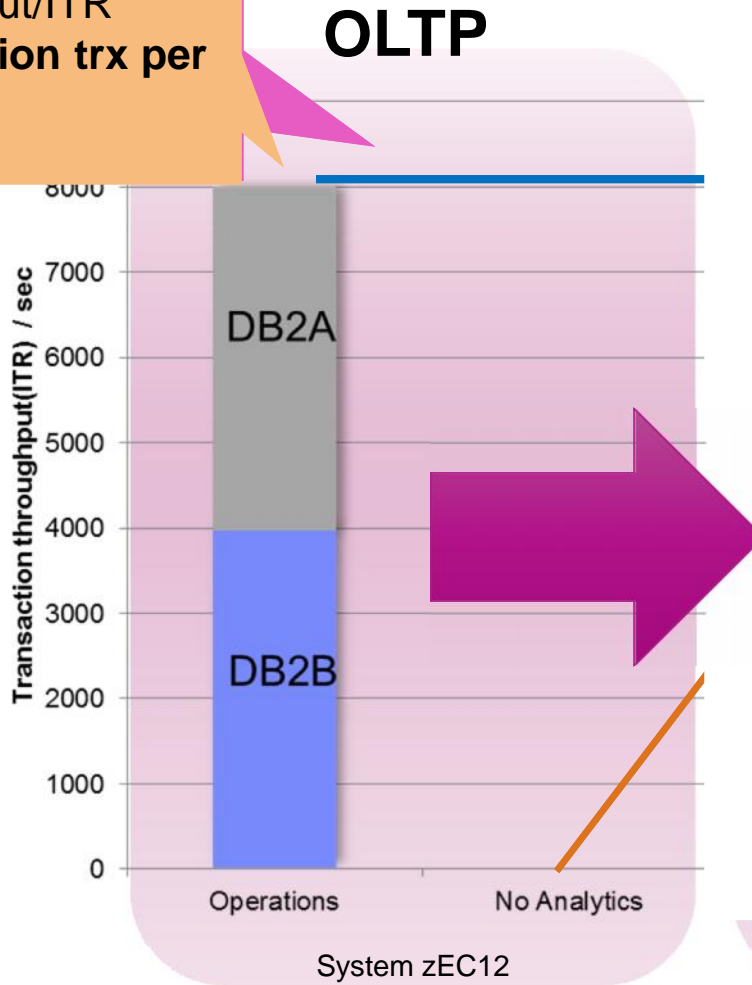

Addition of 13,000
complex analytical
queries per hour,
integrated with
operational workload

System zEC12 and IDAA N2001

DB2 11 for z/OS

Strong uptake out of the gate

- Over 250 customers*
- Faster migration success
- **2x** faster adoption

Out-of-the-box quality/stability

- **70% fewer PMRs**
- **56% fewer APARs**

DB2 10

- Withdraw from Marketing: July 6, 2015
- End of Service: Sept 30, 2017

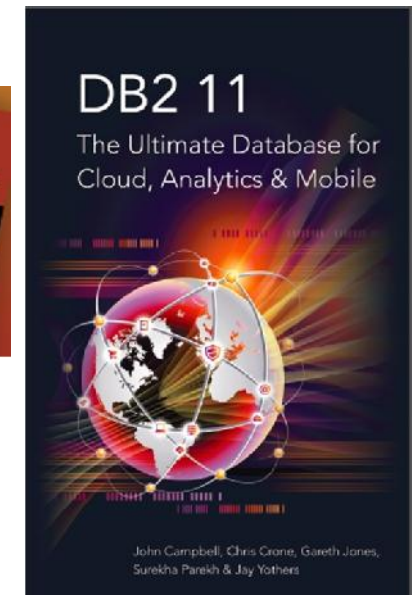
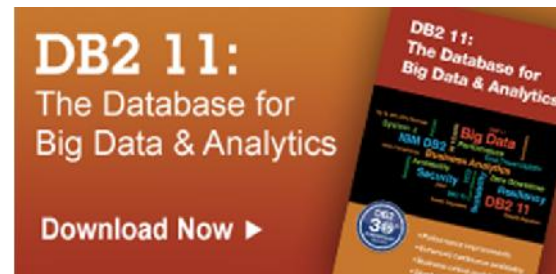

*Fastest SAP certification
in history!*



DB2 11 APAR Trend

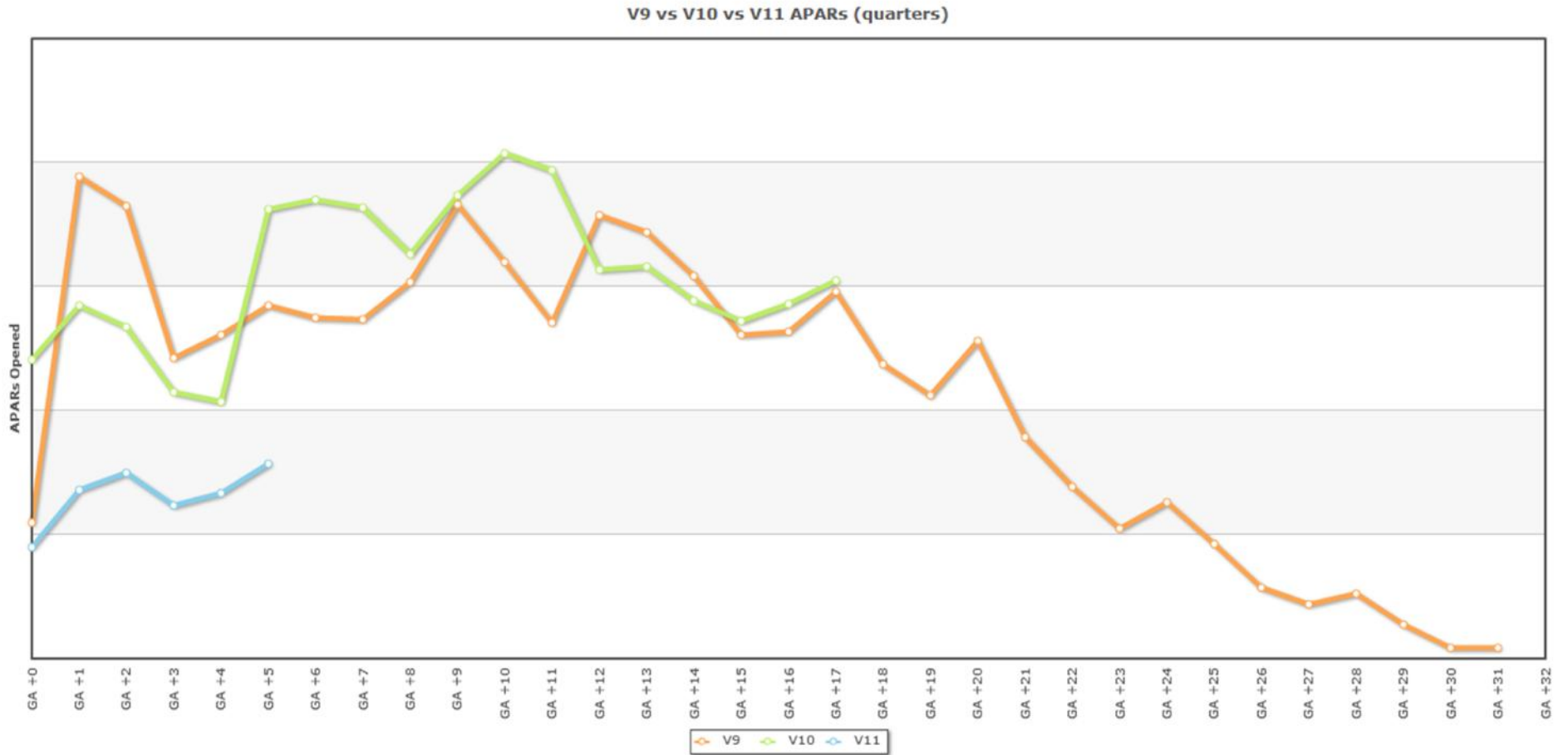

Strong DB2 11 Adoption

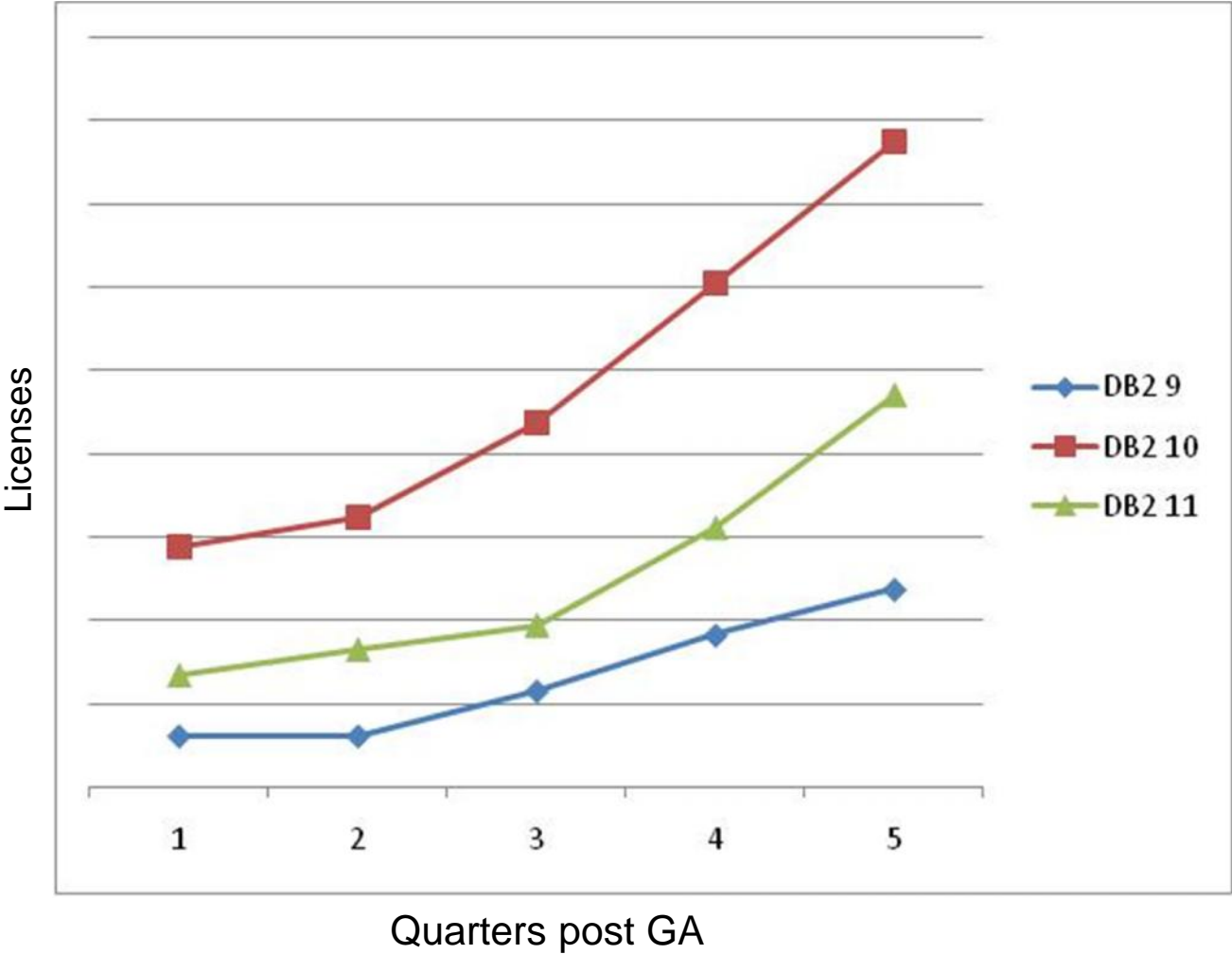

The World's leading businesses run on DB2 for z/OS



92 of the top 100
worldwide banks



10 out of 10 of the
world's largest insurers



6 of the top 10 global
retailers



23 out of 25 of the
world's largest airlines

68 for 6

Mainframes account for 68% of production workloads; but only 6 percent of IT spend

55 percent

of all enterprise applications need the mainframe to complete transactions

80 percent

of the world's corporate data resides or originates on mainframes

91 percent

of surveyed CIOs said new customer-facing applications are accessing the mainframe

DB2 11: The Database for Enterprise OLTP and Analytics

Affordable for every workload with out-of-the-box savings

- Up to 10% for complex OLTP
- Up to 15% for update intensive batch
- Up to 40% for queries

Business critical analytics

- Expanded SQL, XML and analytics capabilities
- Hadoop integration, NoSQL/JSON support
- In-transaction real-time scoring
- Advanced QMF analytic capabilities with mobile support

Enhanced Resiliency and Continuous Availability

- Fewer planned outages, fewer REORGs, faster recovery
- Transparent archiving, access warm/cold data in single query

Simpler, faster upgrades for faster ROI

- 16x faster catalog migration
- No application changes required for DB2 upgrade
- Product quality and stability – raised the bar

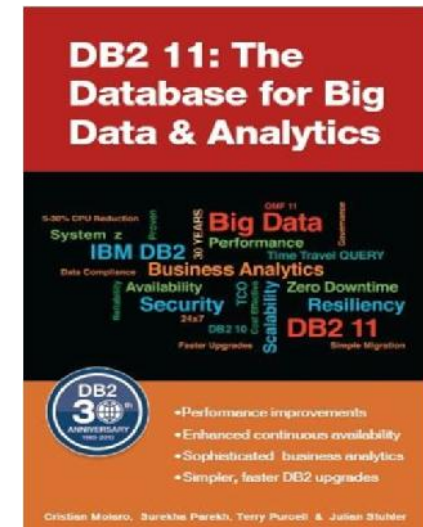

Impressive DB2 11 Performance Results!

DB2 11 % CPU Improvement From DB2 10

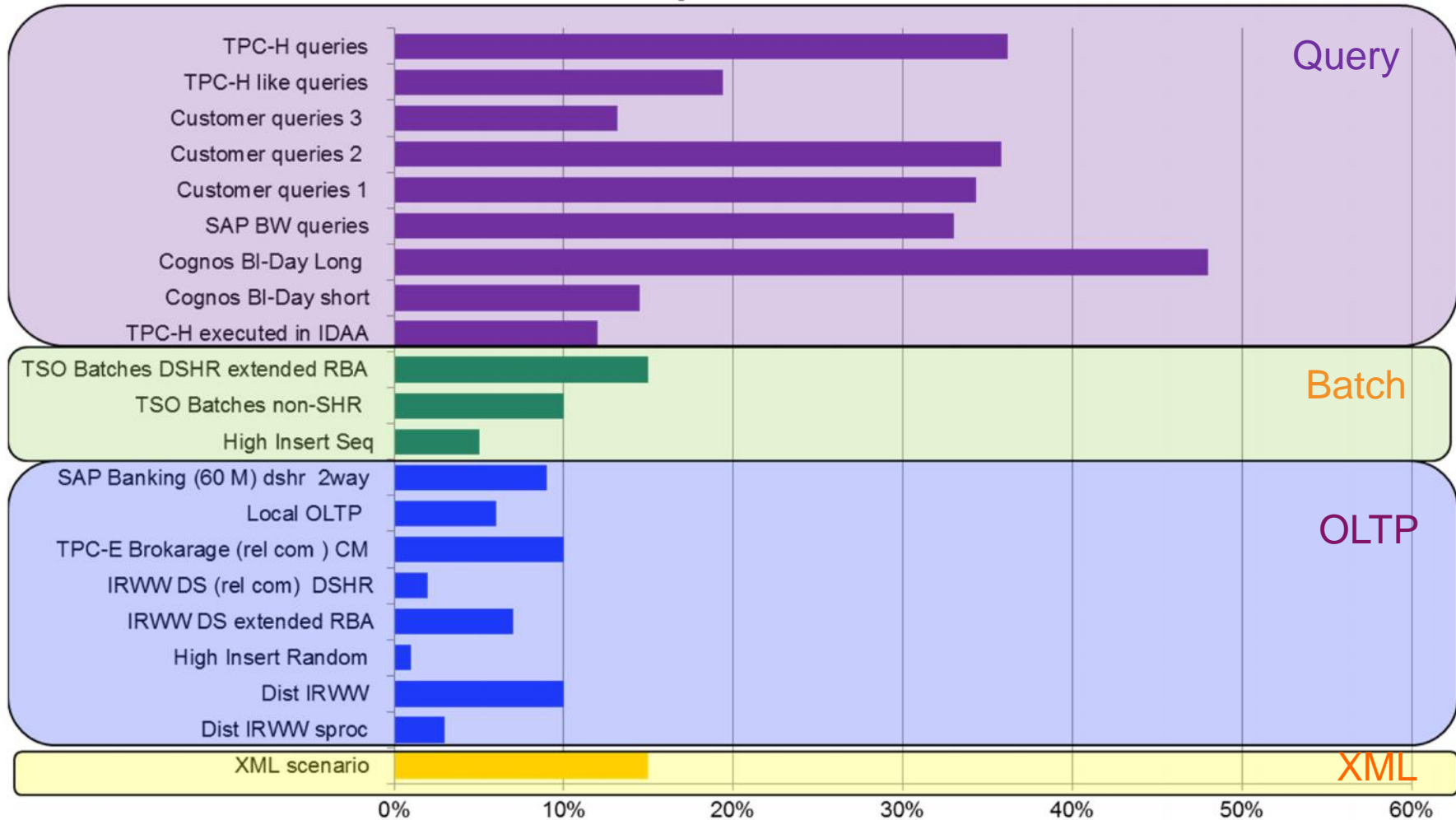

Performance Improvements

no REBIND needed – Partial List

- DDF performance improvements
 - Reduced SRB scheduling on tcp/ip receive using new CommServer capabilities
 - Improved autocommit OLTP performance
- INSERT performance
 - Latch contention reduction
 - CPU reduction for Insert column processing and log record creation
 - Data sharing LRSN spin avoidance
 - Page fix/free avoidance in GBP write
- Automatic index pseudo delete cleanup
- IFI 306 filtering capabilities to improve Replication capture performance
- DGTT performance improvements
 - Avoid incremental binds for reduced cpu overhead
- Utilities performance improvements
- Java stored procedures: multi threaded JVMs, 64-bit JVM – more efficient

Example benefit of DB2 11 performance & pseudo delete cleanup

- Websphere Portal internal measurement
 - At day 1 – 18% CPU saving
 - Due to various DB2 11 performance improvements
 - At day 5 – 39% CPU saving
 - Due to 93% reduction in pseudo-deleted index entries

WAS Portal Workload 5 Days Performance

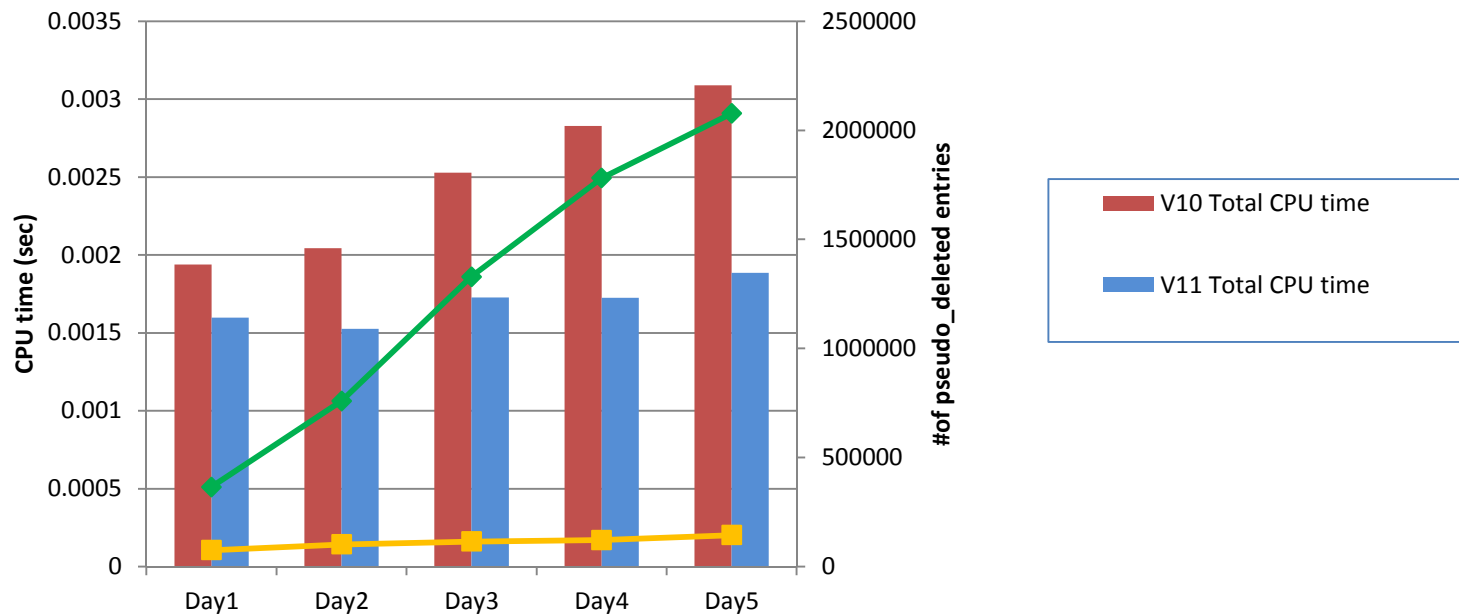

Performance Improvements

REBIND required – Partial List

- Query transformation improvements – less expertise required for performant SQL
- Enhanced duplicate removal
 - Lots of queries require duplicate removal: e.g. DISTINCT, GROUP BY, etc.
 - Dup elimination via sorting can be expensive
 - New techniques: Index duplicate removal, early out
- In-memory techniques
 - In-memory, reusable workfile
 - Sparse index (limited hash join support)
 - Non-correlated subquery using MXDTCACH
 - Correlated subquery caching
- Select list do-once
 - Non column expressions in the select list can be executed once rather than per-row
- Column processing improvements
 - Xproc (generated machine code) for column processing
- DPSI performance improvements
- Data de-compression optimizations
- Optimizer CPU and I/O cost balancing improvements
- DRDA package based continuous block fetch

Performance Improvements

Sysprog, DBA, or application effort required – Partial List

- Suppress-null indexes
 - Index entries not created when all values for indexed columns are NULL
 - Reduced index size, improved insert/update/delete performance, compatibility with other DBMSes
 - Improved utility and CREATE INDEX performance
- New PCTFREE FOR UPDATE attribute to reduce indirect references
- DGTG performance improvements
 - Non logged DGTGs
- Extended optimization - selectivity overrides (filter factor hints)
 - Improve optimizer's ability to find the cheapest access path
 - Collect filter factors for predicates in a Selectivity Profile
- Open dataset limit raised to 200K

DB2 11 enhancements applicable to analytics

- Improved predicate filtering – filtering rows earlier
- Sparse index (in-memory data cache)
- Index skipping and Early-out
- Page range performance improvements
- Sort / Workfile performance improvements
- DPSI query performance improvements
 - DPSI can benefit from page range screening from join
 - Improved DPSI Join Performance (using parallelism)
 - Sort avoidance for DPSIs (also known as DPSI merge)
 - Straw-model parallelism support for DPSI

DB2 and z13 Synergy

- **Increased Uni processor capacity**
 - Up to 10% more capacity per core vs. zEC12
 - Up to 38% more capacity per core vs. z196
- **Bigger/faster cache**
- **Increased System Capacity**
 - Up to 40% more z/OS system capacity
 - Max LPARs increased from 60 to 85
 - Max usable CPs increased from 101 to 141
 - System I/O bandwidth up to 832 GB/sec.
- **Increased memory sizes**
 - Up to 10TB per server
 - Up to 4 TB per z/OS LPAR
- **Significant increase in zIIP processor capacity**
 - zIIPs (and IFLs) are SMT enabled
 - Up to 1.4x capacity per zIIP core vs. zEC12
- **Faster XML parsing through use of SIMD**
- **CFCC Level 20 allows for much larger DB2 CF structures**



IBM z13 and DB2 z : Compete on Speed to Insight and Action

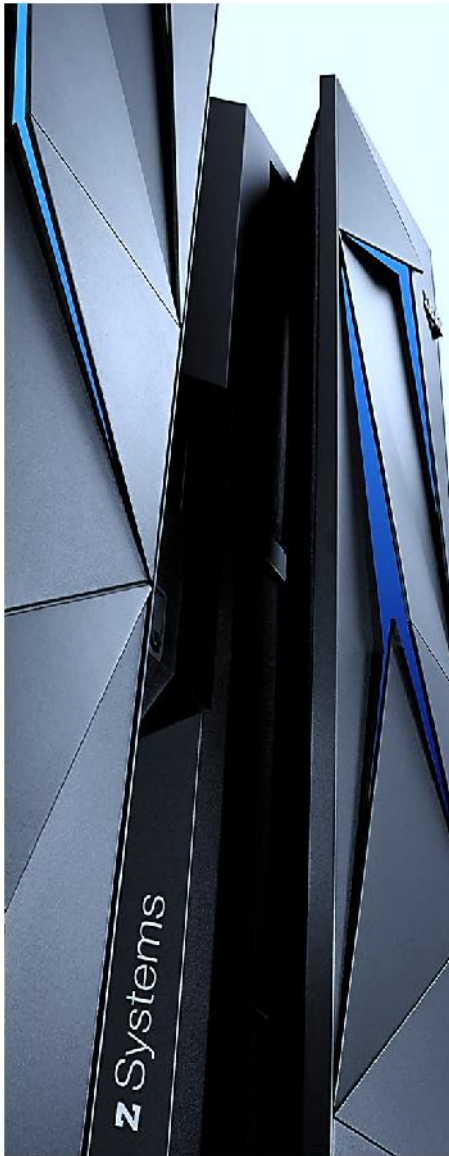

- DB2 workloads showing 4 to 38% range (mostly better than expected 10% improvement)
- 2.4x Reduction in compression cost in utility

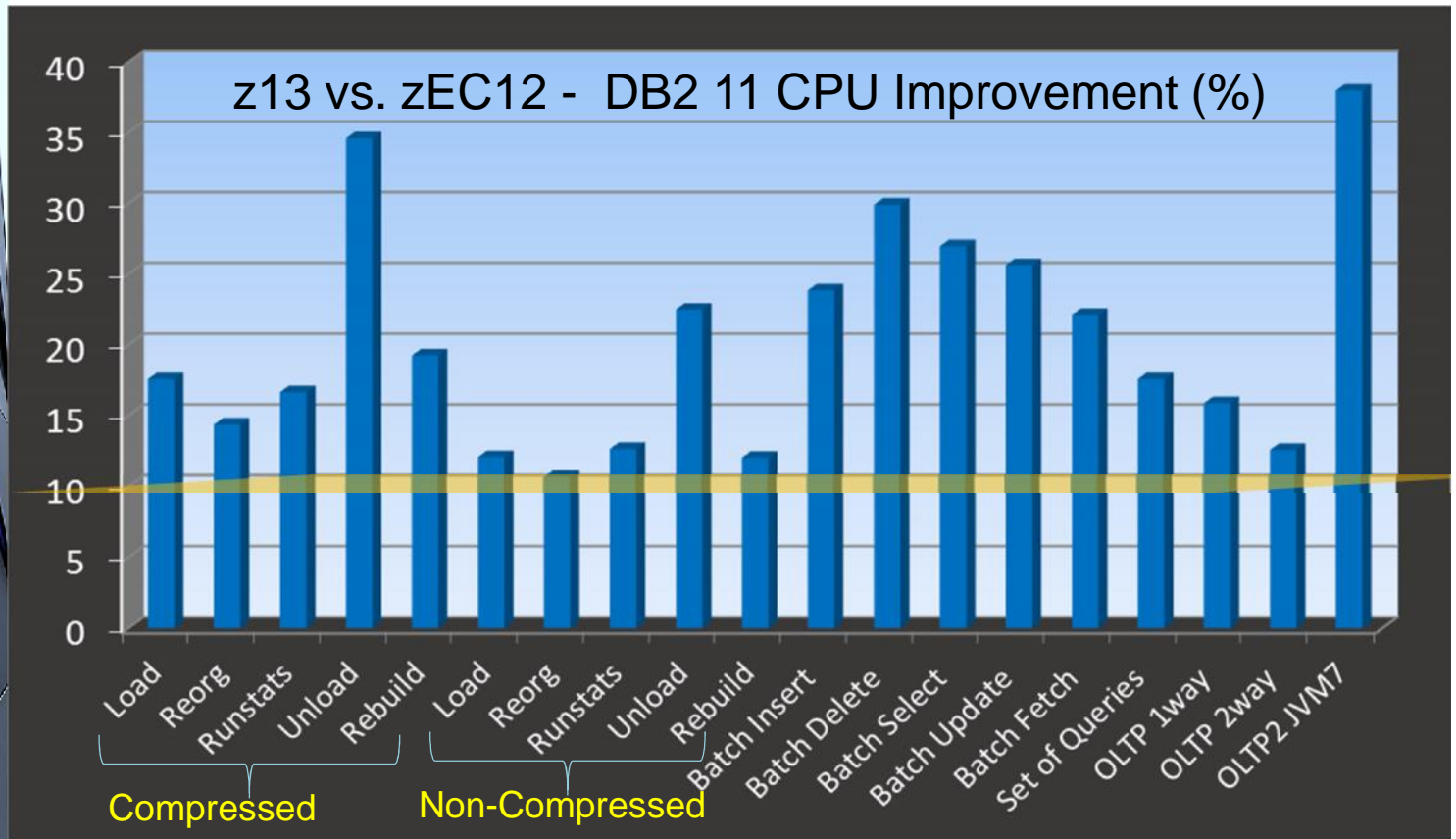

(Controlled measurement environment, results may vary)

z13 - Benefits for DB2 Compression

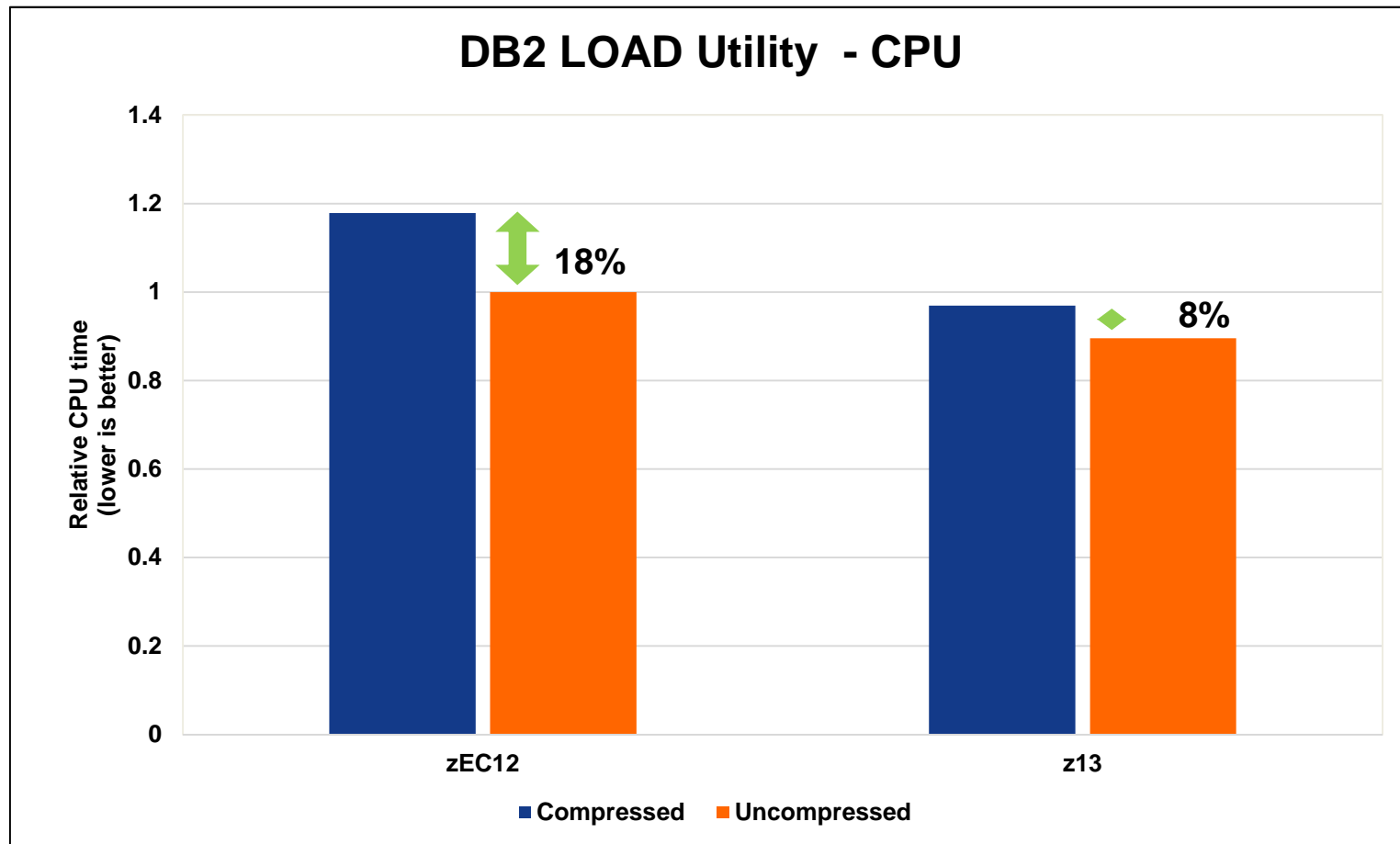

**CPU overhead of DB2 compression is reduced by up to 59% on z13 vs. zEC12
CPU cost of loading to compressed vs. uncompressed tables as low as 8% on z13**

(Controlled measurement environment, results may vary)

IBM z13 and DB2 z : Up to 4TB Memory per LPAR

- DB2 workloads can take advantage of larger memory in z13
- Example : Banking transaction workload showing 24% throughout improvement by expanding DB2 buffer pools from 161GB to 638GB

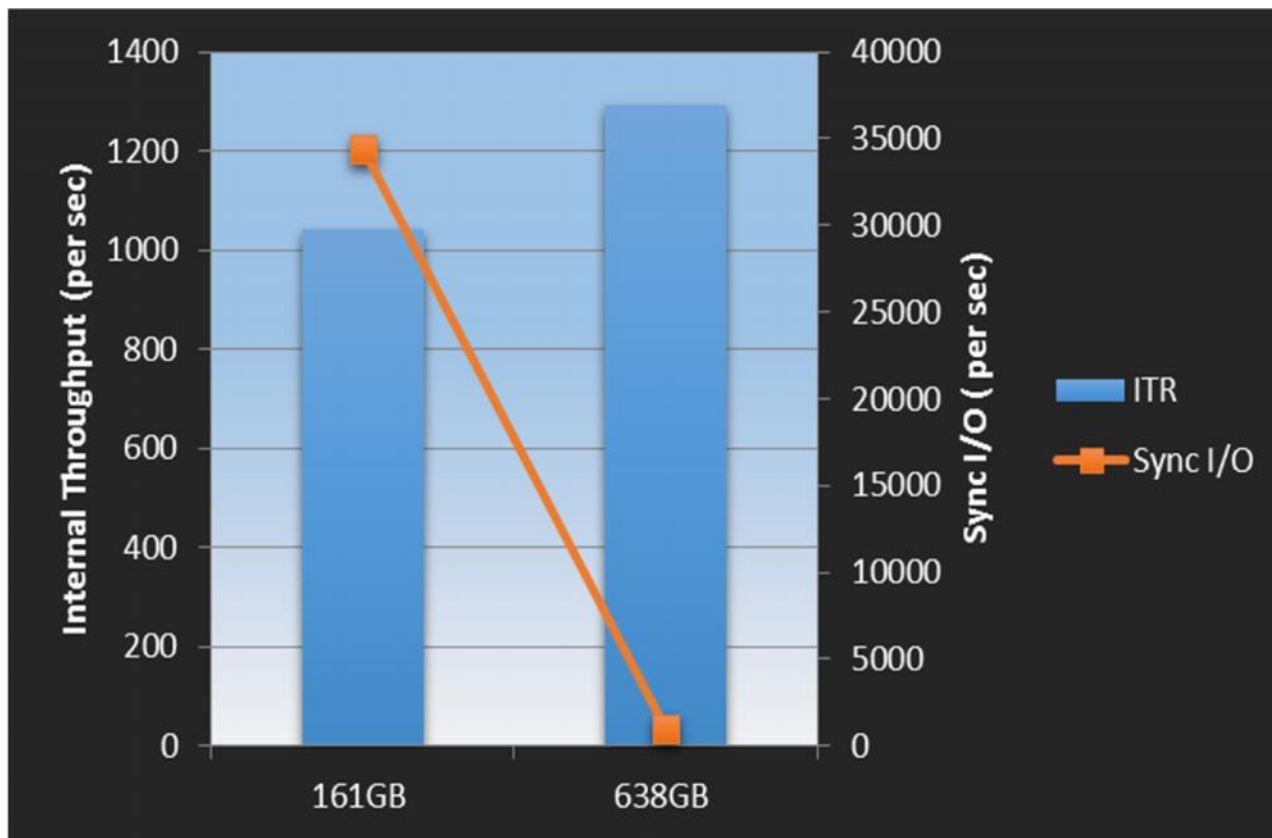

(Controlled measurement environment, results may vary)

DB2 Buffer Pool Simulation - Why?

- Larger buffer pools can potentially reduce CPU usage and transaction response time by reducing sync I/Os
 - The benefit depends on the size of active workload and access pattern
 - Try & validate may not work well with customer's workload with high variations and memory limitations
 - z13 allows for larger memory sizes
- Available tools can be cumbersome to use for simple BP sizing analysis

Buffer Pool Simulation

- Provides accurate estimation of I/O savings of simulated larger BP size
 - Intended for production environments as well as test/dev
- For more sophisticated BP analysis, a tool would still be required
- ALTER BUFFERPOOL command will support
 - SPSIZE (simulated pool size)
 - SPSEQT (sequential threshold for simulated pool)
- DISPLAY BPOOL DETAIL and statistics traces will include
 - Sync and Async DASD I/Os that could have been avoided
 - Sync I/O delay that could have been avoided
- Cost of simulation is small
 - CPU cost : approximate 1-2% per buffer pool
 - Real storage cost : approximate 2% of simulated pool size (4k page size, less for larger page sizes)
 - For example, SPSIZE(1,000K) requires approx. 78MB additional real storage (4k page size)
- DB2 11 APAR PI22091
- Refer to DB2 11 for z/OS Managing Performance publication, SC19-4060

DB2 10/11 : Benefits with Larger Memory

- **DB2 local and group buffer pools**
 - Reduction of elapsed time and CPU time by avoiding I/Os
- **Large page frames**
 - CPU reduction through better TLB efficiency
- **Thread reuse with IMS or CICS applications**
 - Reduction of CPU time by avoiding thread allocation and deallocation
- **Thread reuse and RELEASE(DEALLOCATE)**
 - Reduction of CPU time by avoiding package allocation and parent locks
 - DDF High performance DBATs support with DB2 10
 - Ability to break-in to persistent threads with DB2 11
- **Global dynamic statement cache**
 - EDMSTMTC up to 4G with DB2 11, default 110MB
 - Reduction of CPU time by avoiding full prepare
- **Local statement cache**
 - MAXKEEPD up to 200K statements with DB2 11, default 5000
 - Reduction of CPU time by avoiding short prepare
- **In-memory data cache**
 - MXDTCACH up to 512MB per thread, default 20MB
 - Reduce CPU/elapsed time with potentially better access path selection with DB2 11

zHyperWrite for z/OS, DB2 and DS8870

New zHyperWrite function for DB2, z/OS and DS8870 with GDPS or TPC-R HyperSwap

- Delivered year end 2014
- Leverages synergy of z/OS and DS8870 replication technologies
- Designed to accelerate DB2 Log Writes in Metro Mirror environment
 - Benefits include:
 - Improved DB2 transactional latency
 - Log throughput improvement
 - Additional headroom for growth
 - Improved resilience for workload spikes
 - Potential cost savings from workload consolidation
- DB2 commit response time reduced up to 40%
 - Benefit percentage varies with distance
 - Requires:
 - zHyperWrite function in z/OS 2.1, with the PTF for APAR OA45662
 - DB2 10 and DB2 11 with PTF for APAR PI25747
 - IBM DS8870 Storage Subsystem MCL



HyperWrite with DB2 Batch Updates

- A customer running 2.7 millions update (commit every 3 updates)
- 28% DB2 elapsed time improvement by reducing log write wait during update commit, 26% Job elapsed time improvement.

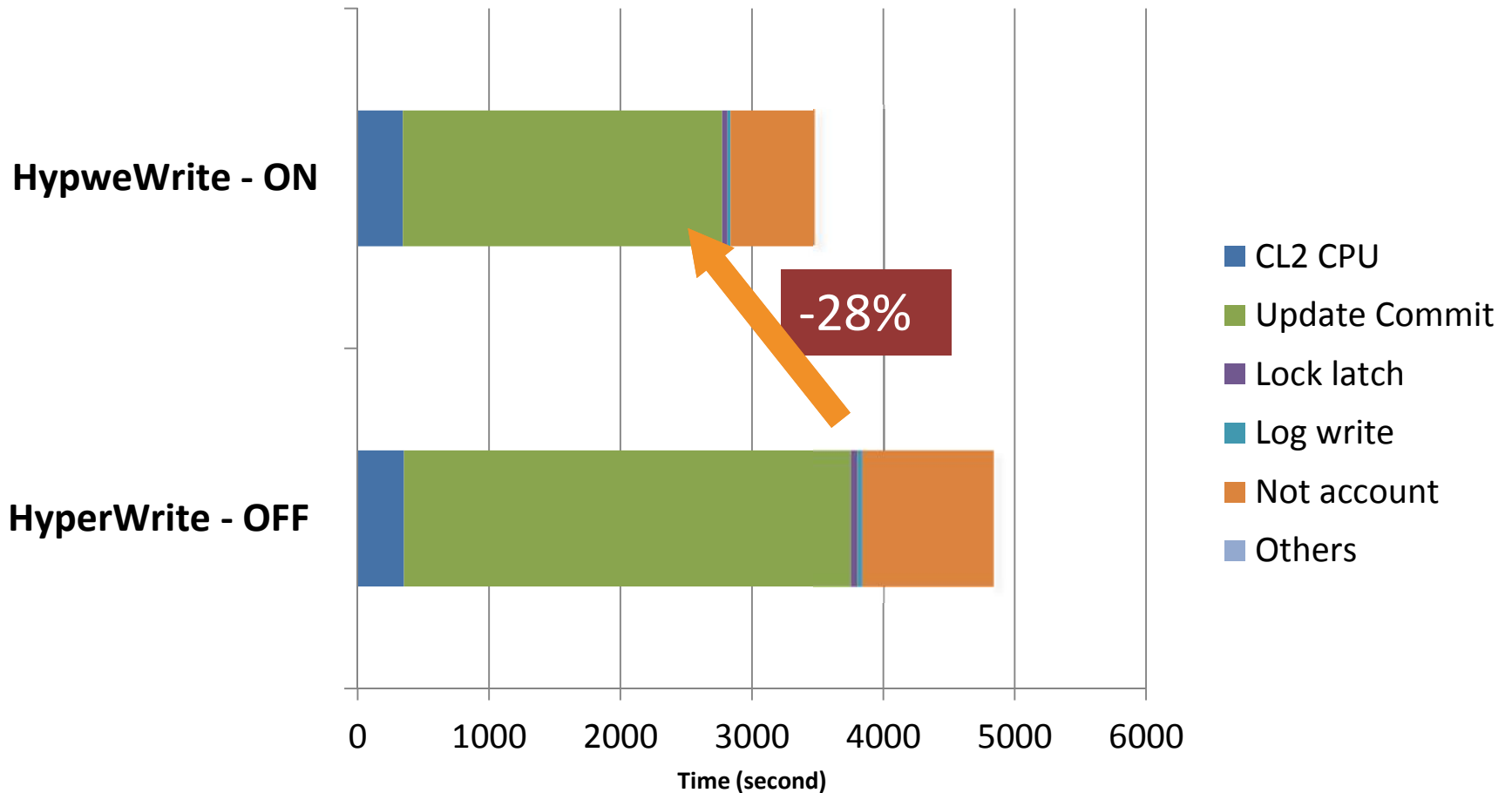

DB2 Integration with DS8870 Easy Tier

- Easy Tier is a “multi temperature” data placement solution, automatically putting frequently accessed data on SSDs, lesser accessed data on HDDs
- Problem: with DB2 REORGs, the Easy Tier control info can be lost for DB2 objects, causing sub-optimal placement
- New Enhancement: DB2 REORG utility communicates dataset usage control info so that new (shadow) dataset(s) inherit control info from the base dataset(s)
- Avoids I/O performance degradation after REORG with Easy Tier
- DB2 APAR PI35321, V10 and V11
- z/OS 1.13 or above (APAR will be provided)
- DS8870 R7.4 or later



**z Systems and
DB2 leadership
and innovation!**

DB2 11 RAS and Usability Improvement Highlights

- Logging capacity and performance: RBA/LRSN optionally expands to 10 bytes
- BIND / DDL / Online REORG break-in for persistent threads
 - Avoid having to shut down apps to get a REBIND through, e.g. for application upgrades
- More online schema changes
 - Alter partitioning limit keys
 - DROP column
 - Point in time recovery support for deferred schema changes
- Autonomics improvements
 - Automatic index pseudo delete cleanup
 - Overflow row reduction
 - Optimizer externalizes missing stats to enable automated RUNSTATS

99.999% availability because
your business never stops.!

DB2 11 RAS and Usability Improvement Highlights...

- Data sharing improvements
 - Group buffer pool write-around
 - Restart light enhancements
 - Index split performance and other indexing improvements
 - Castout performance improvements
 - Full LRSN spin avoidance
- Plan management improvements -
APREUSE(WARN) support
- ACCESS DATABASE ... MODE(STATS) option to
externalize RTS statistics

99.999% availability because
your business never stops.!

Security Enhancements

- Remove inconsistencies between DB2 and RACF access controls
 - Automatic DB2 cache refresh when RACF changes are made
 - Package auth cache, dynamic statement cache, user authentication cache
 - Support BIND OWNER when using RACF exit
 - Support auto REBIND using owner's authid when using RACF exit
 - Dynamic SQL authorisation checking improvements
 - Honor DYNAMICRULES(BIND) rules
- Bind plan option to ensure the program is authorized to use the plan
 - New PROGAUTH bind option
- Remove column masking restrictions for GROUP BY and DIST



Summary of Utilities Improvements

- Over 40 new enhancements!
- Availability
 - Online data repartitioning
 - REORG REBALANCE SHRLEVEL(CHANGE)
 - Online ALTER of limit keys
 - Online REORG availability improvements
 - SWITCH phase reduction
 - Improved drain processing
 - Part level inline image copies for REORG
- Usability
 - Online REORG automated mapping tables
 - REORG delete unused PBG datasets
 - System cloning improvements
- CPU reduction
 - More zIIP offload for LOAD and RUNSTATS
- Performance
 - Faster LOAD processing via increased parallelism
 - Inline statistics improvements, reduced need for RUNSTATS
 - Optimizer input to statistics collection
 - REORG option to avoid sorting data for clustering
 - Improved buffer pool efficiency



Easier DB2 Version Upgrade

- Application Compatibility (APPLCOMPAT)
 - New feature to ease DB2 version upgrades – avoid impact to applications
 - New mechanism to identify applications affected by SQL changes in the new release
 - Seamless mechanism to make changes at an application (package) level or system level
- Faster ENFM processing
 - Lab measurement showed 18x faster in V11 vs. V10 using a large customer catalog
- Access path stability improvements
- Higher code quality stability levels
- SQL Capture/Replay tooling can help testing of DB2 version upgrades
- Migration Planning Workshops (MPW)
 - See the DB2 11 MPW community in DeveloperWorks for latest info

We have seen some really good results regarding CPU savings - we have been so impressed with the product stability and have already moved an internal production system to DB2 11”

Stefan Korte GAD

zCloud Services

- IBM z development teams are working on Cloud-enabling z/OS services: WebSphere, CICS, IMS, DB2, MQ along with core z/OS features like security and network
- Plan to provide REST interfaces to easily integrate these services into various tools or applications



High level architecture

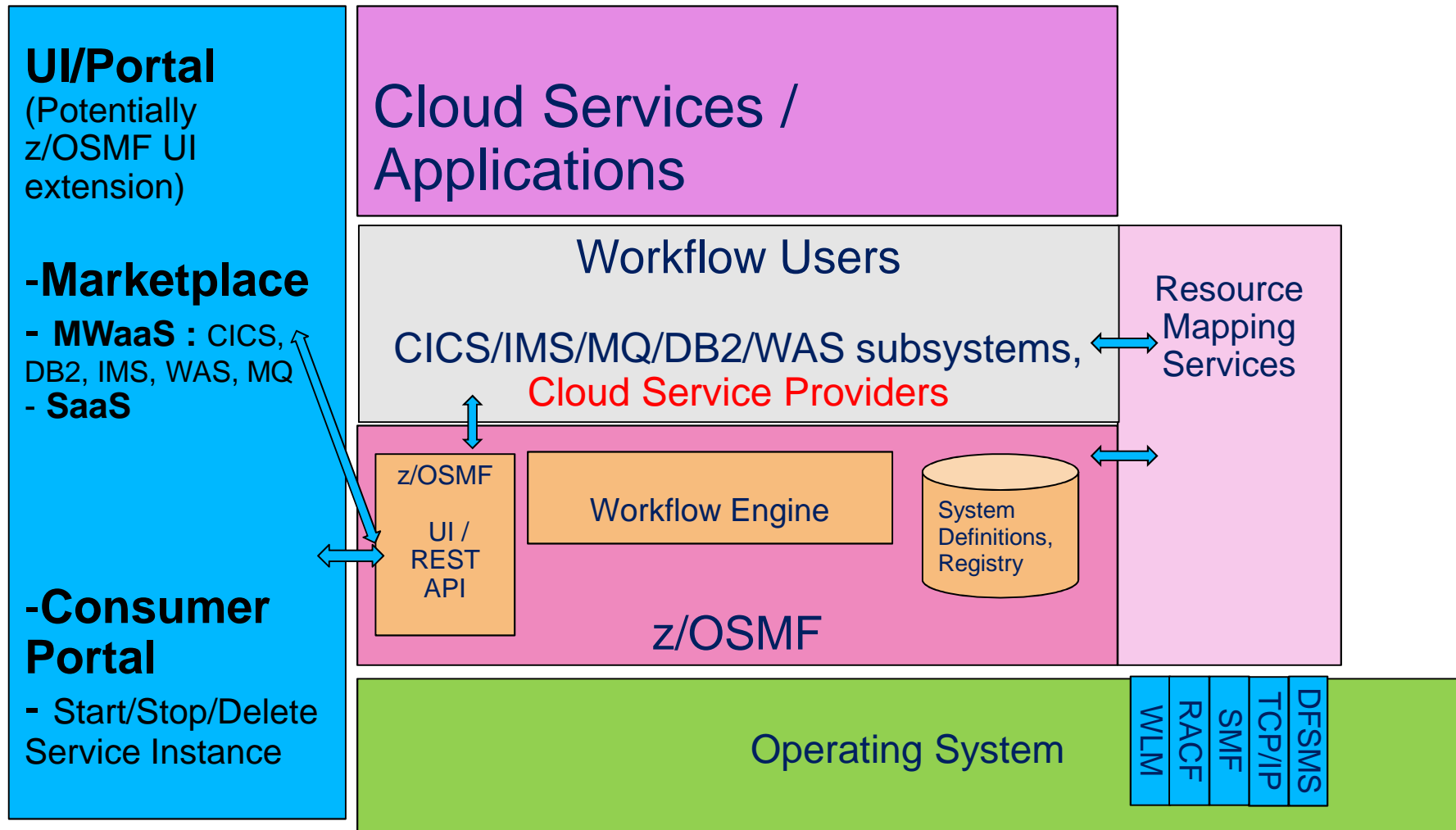

DB2 for z/OS aaS

- Fast provisioning a DB2 environment as part of provisioning a software stack
 - DB2 environment scope can be
 - DB2 system
 - Migrate to a new version of a DB2 system
 - Database in an existing DB2 system
 - Copy of an existing database
 -

- z is a highly virtualized shared multi tenant environment and many people need to be involved for the provisioning
 - SME (division of responsibilities) for different aspects of system management like storage, network, security, ... and DB2 system management
 - DB2 Installations are highly customized across different companies

z/OS Management Facility (z/OSMF) Can Help

- IBM z/OS Management Facility (z/OSMF) delivers on IBM's strategy for mainframe simplification and modernization
- Is a free feature of z/OS
- Provides a modern browser based interface for managing the z/OS system
- Helps to automate management tasks to
 - Reduce the learning curve and improve productivity
 - Helps guide users easily through tasks with embedded user assistance (such as wizards)
 - Helps accelerate productivity, making navigation and task steps more seamless
 - Makes administration more intuitive
- Extended to simplify management of z/OS subsystems like DB2

DB2 Fast Provisioning

- Use Case 1 – Migrate to a new version of a DB2 system
 - DB2 11 plan to provide new Procedure to Migrate a DB2 with z/OSMF
 - Enhanced CLIST to allow for z/OSMF variable selection
 - Generated z/OSMF artifacts for customization and z/OSMF deployment

- Use Case 2- Install new DB2 subsystem
 - DB2 11 plan to provide new Procedure to Install a DB2 with z/OSMF
 - Enhanced CLIST to allow for z/OSMF variable selection
 - Generated z/OSMF artifacts for customization and z/OSMF deployment

DB2 development plans to provide z/OSMF workflows to automate install/migration of DB2, along with REST APIs over the workflows that can be invoked by cloud / deployment tooling. Planned for June, 2015

DB2 Fast Provisioning...

- DB2 Services
 - Multi-tenancy style provisioning
 - **z/OS Connect to expose SQL as service**
 - Leveraging existing DB2 Admin Tool capability with z/OSMF workflows
 - Sub system style provisioning → **z/OSMF workflows**
 - SAP and SAP like Customers

Mobile/Cloud support – Problem Statement

- Cloud and Mobile providers **need a uniform way to interact with z-based middleware for discovery, provisioning, data transformation, and service invocation.**
- Customers have expressed an interest in a common way to interact with all z/OS business and **infrastructure assets using REST and JSON technology**
 - REST – Representational State Transfer ... the Other use of HTTP URLs that map to a 'service', such as 'query account' or 'update data'
 - JSON – JavaScript Object Notation ... a standard of representing data as a set of name/value pairs. This is passed back and forth along with REST request/responses
- Ability to track and handle large spikes of new requests originating from any number of almost instantly available clients.

Introducing z/OS Connect

- Enhanced Mobile and Cloud connectivity to backend z/OS assets
- Provides a consistent way to discover and call in to application assets on z/OS
- Runs in Liberty profile
- Uses RESTful service and JSON
- Capable of converting JSON to data format required by backend service
- No additional cost, packaged with WAS, CICS and IMS and in future with DB2
- Java, so runs on specialty engines
- Example of invocation

- `http://<hostname>:<port>/zosConnect/services/CUSTOMER_INQ?action=invoke<JSON payload>`

```
{  
  "firstName": "John",  
  "lastName": "Smith"  
}
```

IBM z/OS Connect

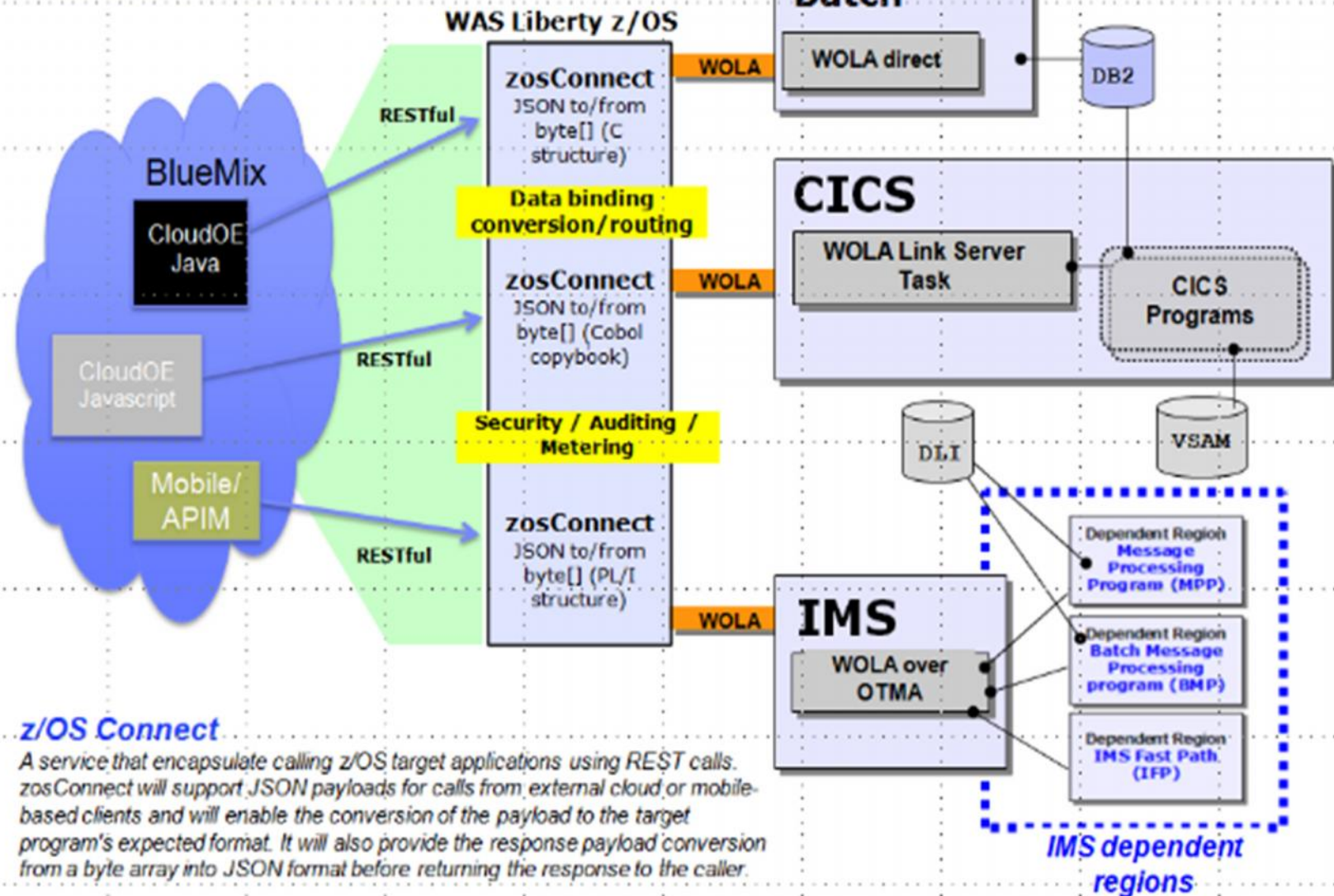

z/OS Connect

A service that encapsulate calling z/OS target applications using REST calls. zosConnect will support JSON payloads for calls from external cloud or mobile-based clients and will enable the conversion of the payload to the target program's expected format. It will also provide the response payload conversion from a byte array into JSON format before returning the response to the caller.

DB2 Adaptor for z/OS Connect Preview

- DB2 Adapter for z/OS Connect will be an integrated solution that enables developers to make existing DB2 assets – SQL and Stored Procedures – more accessible in today's growing mobile and cloud application ecosystem
- Will consist of 3 components
 - z/OS Connect license
 - DB2 Adapter for z/OS Connect
 - DataStudio
- DB2 Adapter for z/OS Connect ships via Accessory Suites
 - DB2 10 and DB2 11
 - Some WAS skill needed to install and configure
- Planned availability in 3Q 2015

DevOps

IBM UrbanCode Deploy extends provisioning for Systems of Record

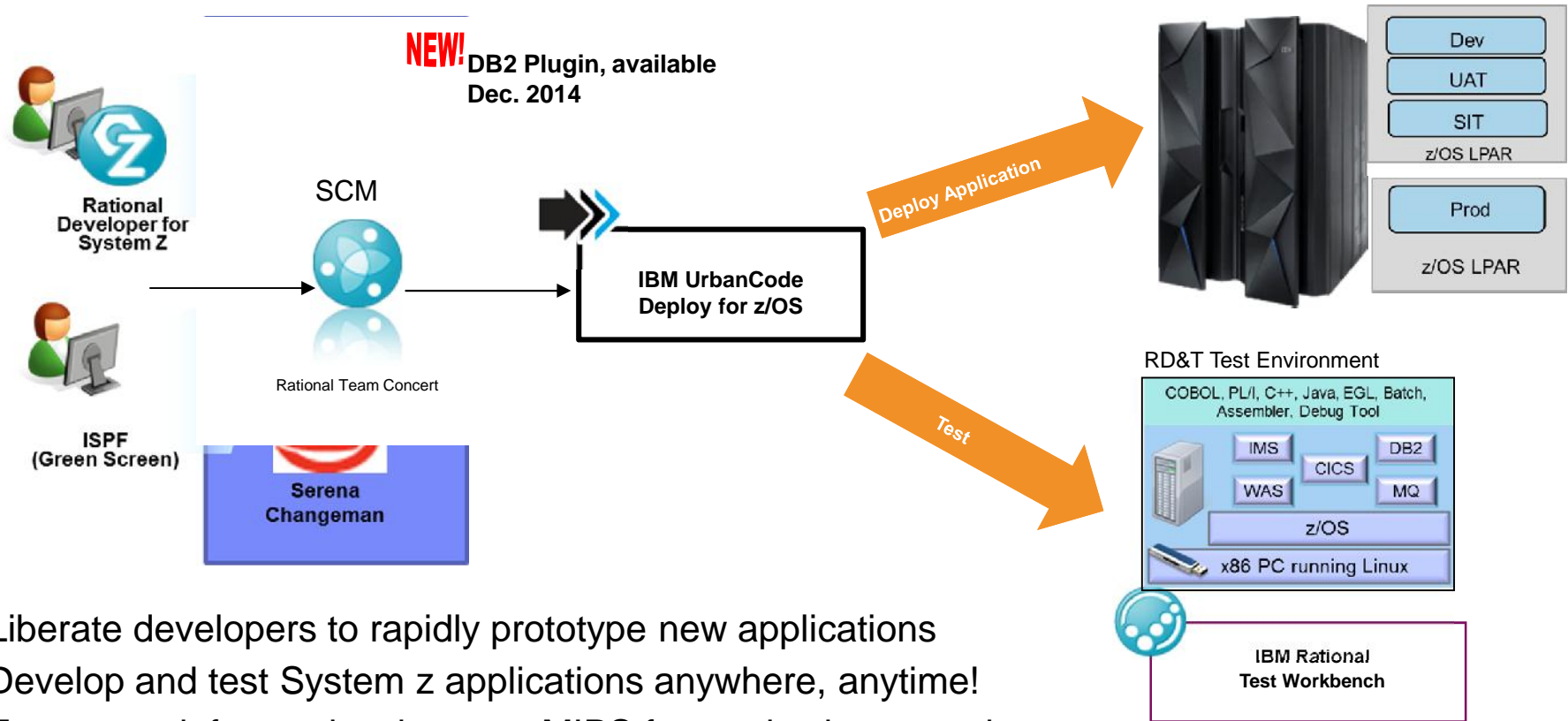

- Liberate developers to rapidly prototype new applications
- Develop and test System z applications anywhere, anytime!
- Free up mainframe development MIPS for production capacity
- Eliminate costly delays by reducing dependencies on operations staff

DB2 11 Expanded Application Capabilities

- Global variables
- SQLPL improvements: array data type, autonomous transactions
- Alias support for sequence objects
- Temporal data enhancements
 - Support for views
 - Special register support
 - Integrated auditing support (planned)
- Transparent archive query
- SQL Grouping Sets, including Rollup, Cube
- Unicode column support for EBCDIC tables
- Hadoop access via table UDF
- JSON support

Transparent Archive Query

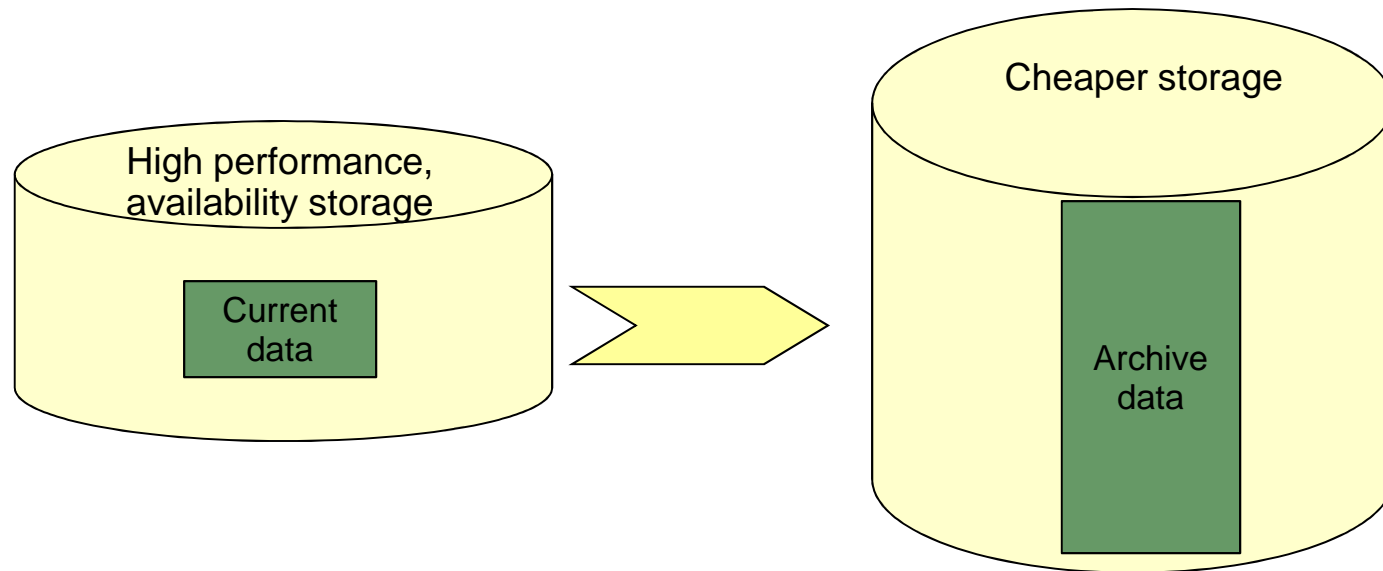

Applications can query current + archive with no SQL changes

By default, data is retrieved from base table only, as usual

Set a new global variable when archive data is desired

DB2 automatically converts SQL to UNION ALL via dynamic plan switching technique (high performance)

Archiving process is user-controlled

Move_To_Archive global variable allows DELETES to be automatically archived

Bring Analytics to the Data, Reduce ETL

Converge analytics with data and transaction environments where data exists on the platform, and actively encourage the growth of data hosted on System z.

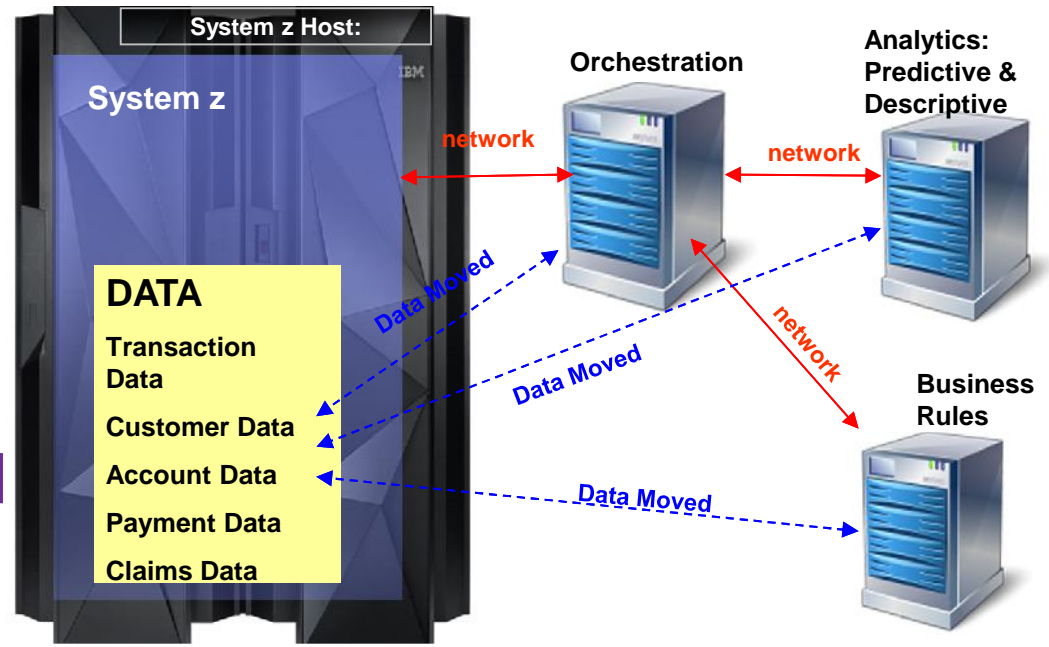

WHY?

- System z **already hosts a majority of the systems of record data** that feeds business analytics
- Unparalleled, **proven performance execution** of combining transactional data environments, analytics & rules
- **Best of breed security** for sensitive data
- **Extensive logging** for data and transaction governance
- **Existing comprehensive, tested HA / DR capabilities**
- **Cost savings** from reduced systems, software & people
- **Plug and play capacity extensions and migrations** enabling **quick production application deployment** with **no downtime**

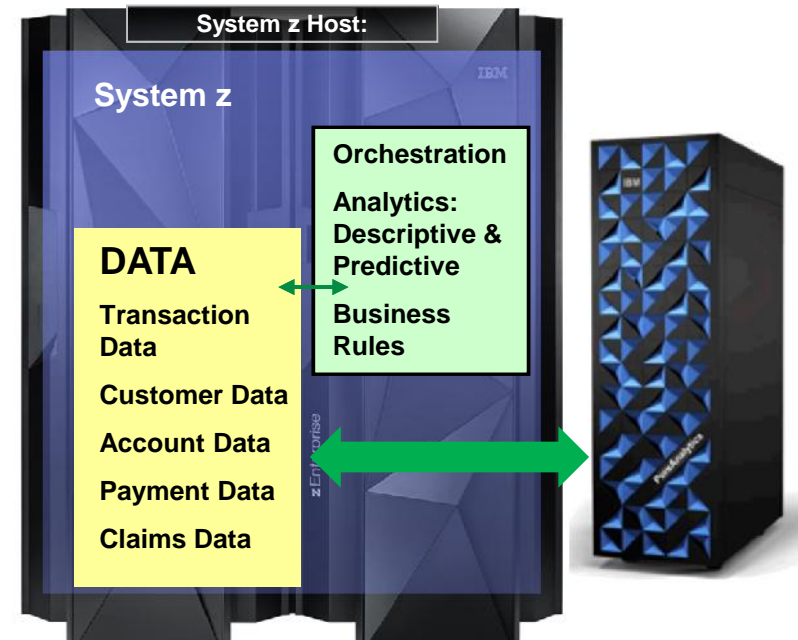

In-Database Analytics in DB2 for z/OS

SPSS Modeler Server Scoring Adapter for z Systems

- Execute predictive **models inside DB2 for z/OS**, with little data movement
 - Scores executed **10-50x faster** than making calls to remote scoring engines
 - Achieve **huge scale** of execution without performance degradation
 - Leverage historical and current transaction data to produce **most accurate results**
 - Plans to exploit z13 SIMD for higher performance
 - Exploits DB2 UDF enhancements

Available System z business solutions
that use this technology:

- **IBM System z Smarter Analytics for Banking**
anti-fraud and anti-money laundering focus
- **IBM Signature Solution**
anti-fraud, waste and abuse for Healthcare and Insurance
- **IBM Signature Solution**
anti-fraud, waste and abuse for Tax
- **IBM Signature Solution for Next Best Action**

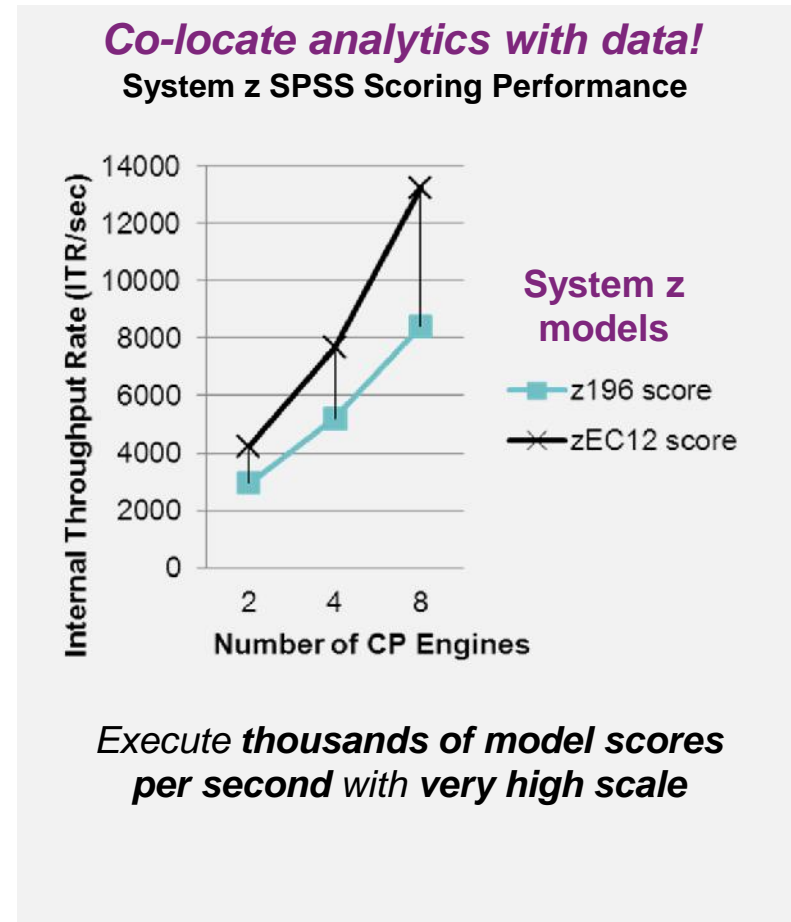

DB2 11 Expanded Analytics Capabilities

- Significant query performance improvements
 - Without accelerator
- SQL Grouping Sets, including Rollup, Cube
 - Rollup is helpful in providing subtotaling along a hierarchical dimension such as time or geography
 - CUBE is helpful in queries that aggregate based on columns from multiple dimensions
- High performance SPSS in-database scoring via PACK/UNPACK (rolled back to v10)
- Hadoop access via table UDF
 - UDFs shipped with BigInsights
 - Uses new V11 generic table UDF capability
- JSON support

Integrating Big Data Analytics with DB2 for z/OS

- **Much of the world's operational data resides on z/OS**
- **Unstructured data sources are growing fast**

▪ Two significant needs:

1. Merge this data with trusted OLTP data from zEnterprise data sources
2. Integrate this data so that insights from Big Data sources can drive business actions

New V11 features enable this

- Connectors to allow BigInsights to easily & efficiently access DB2 data
- DB2 is providing the connectors & the DB capability to allow DB2 apps to easily and efficiently access hadoop data sources

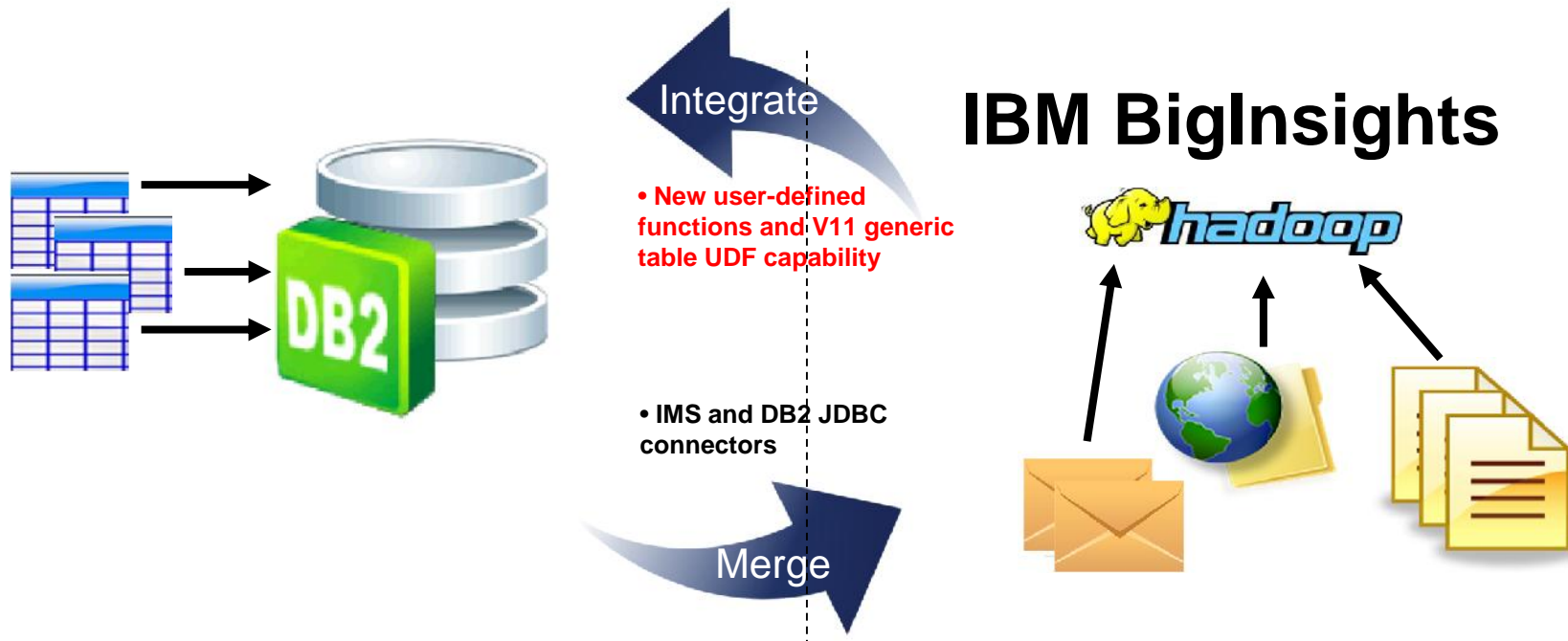

InfoSphere BigInsights for Linux on System z - 2.1.2

Secure Perimeter

GA'd
Aug 5
2014

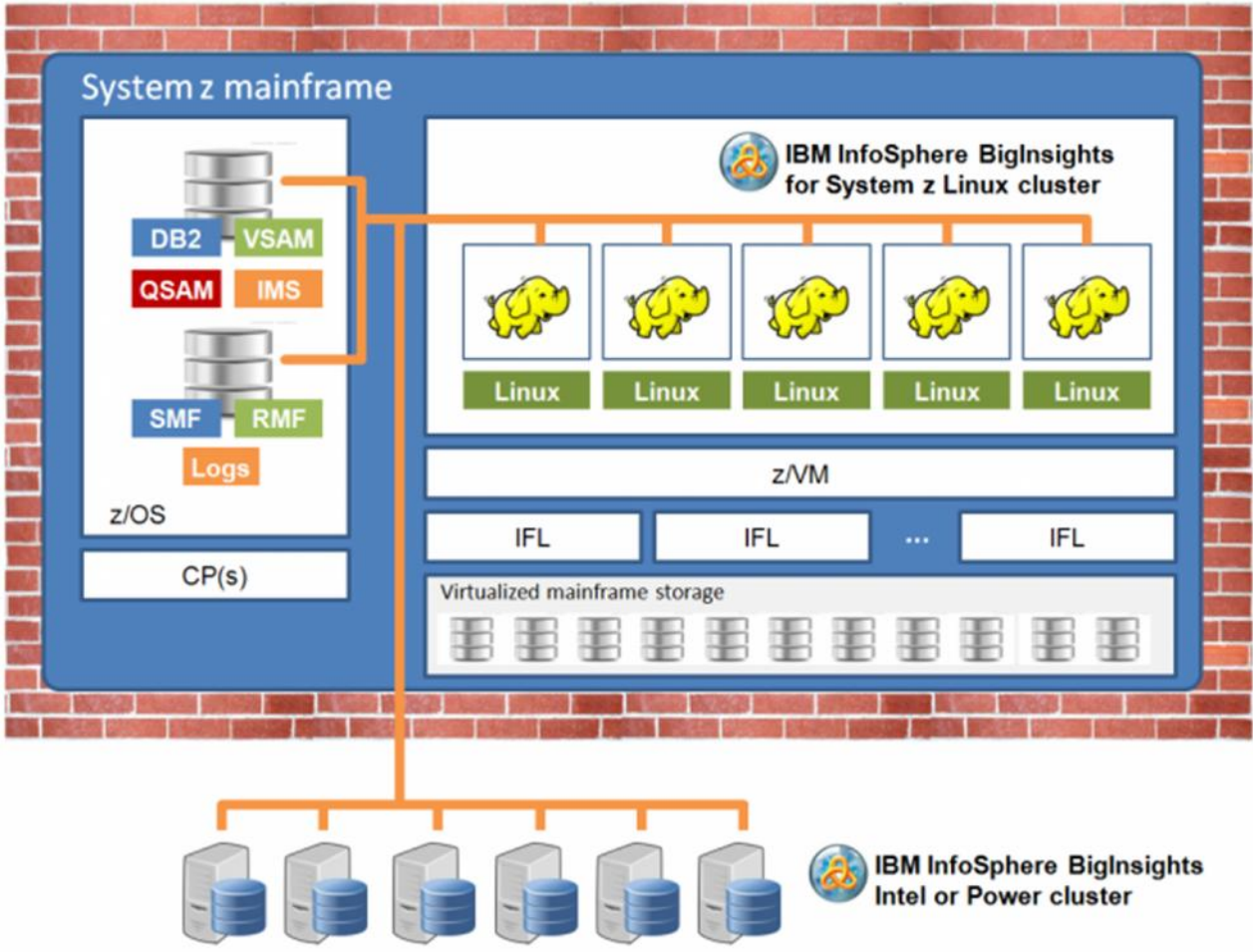

InfoSphere System z Connector for Hadoop

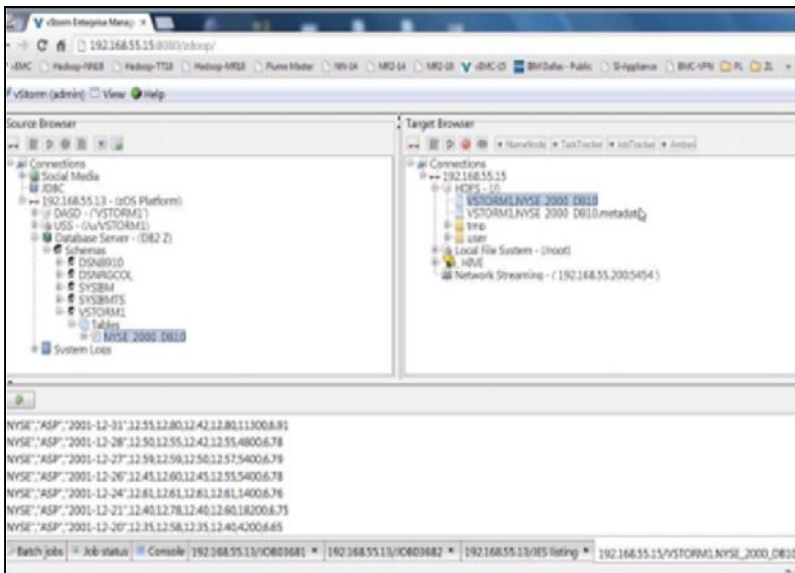
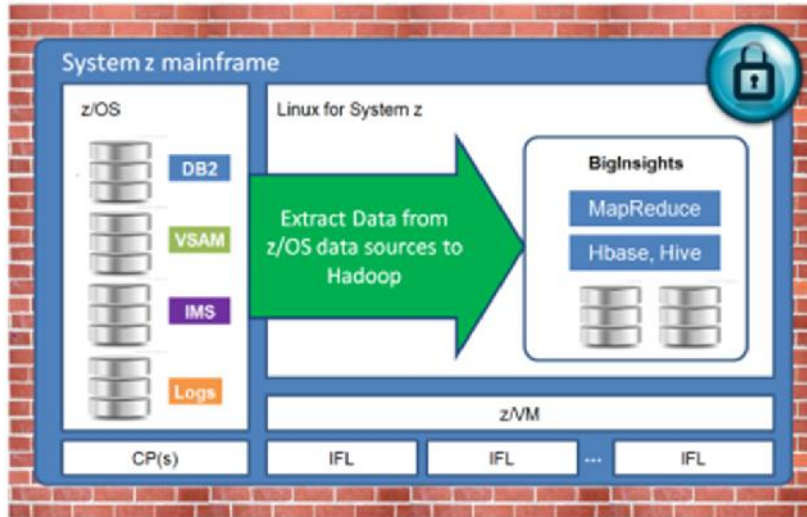

Easy to use ingestion engine

- Native data collectors accessed via graphical interface
- Light-weight; no programming required
- Multiple z/OS data sources
- Conversions handled automatically
- Streaming technology leverages USS (no z/OS engines) with no DASD required for staging

A secure pipe for data

- RACF integration – no need for separate or special credentials
- Data streamed over secure channel using hardware crypto
- Combining with BigInsights for Linux on System z means data never leaves the box

Mainframe efficiencies

DB2 11 Planning

- Dual mode migration (CM, ENFM, NFM)
- DB2 10 is the platform for migration
- z/OS 1.13 or above. z10 or above.
- No pre-V9 bound packages
- DB2 Connect:
 - DB2 11 continues to support all levels of DB2 Connect
 - V10.5 FP4 recommended to exploit some new DB2 11 features
 - Refer to DB2 11 Program Directory on the web
- Sysplex query parallelism support is removed

DB2 for z/OS Timeline

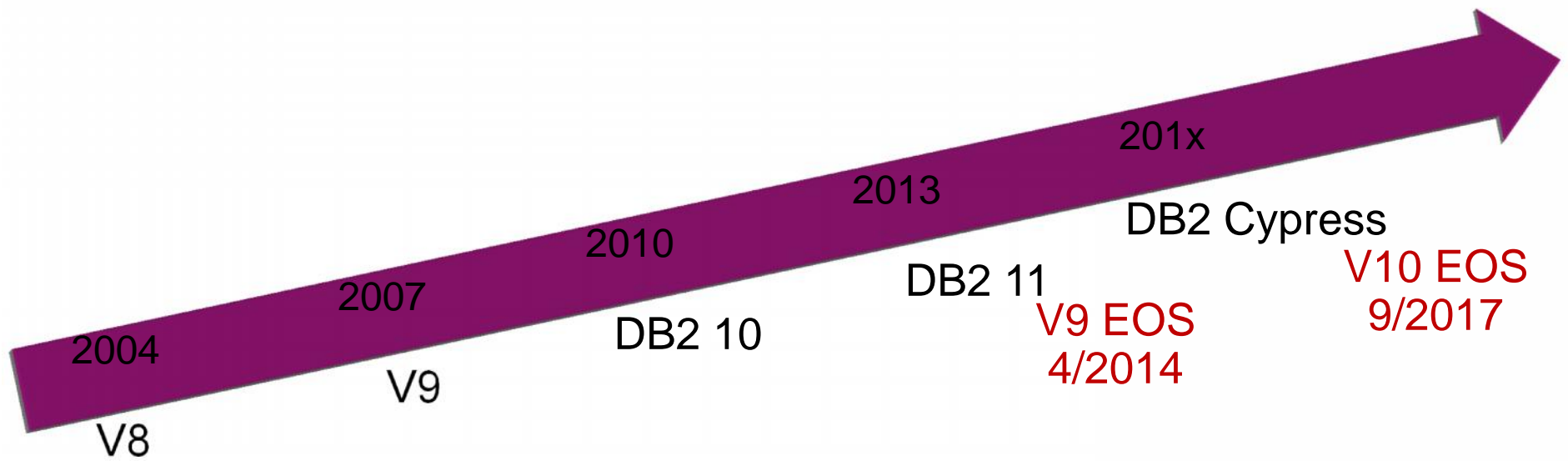

DB2 Cypress Themes

Performance

- Expanded in-memory processing
- CPU reductions expected for most workloads
- Faster insert and easier insert performance mgmt

DBA productivity, autonomies

- More schema and partition flexibility
- Stay ahead of mobile, internet-of-things:
Extreme scale tables, indexes
- Streamlined and less disruptive migrations
- Security, compliance improvements

Application enablement

- IDAA improvements to expand to new use cases
- Cloud-based data or database as-a-Service provisioning
- SQL improvements to address key customer requirements



DB2 Cypress Planning

- DB2 11 NFM is the prereq for migration
- Single phase catalog migration
- z/OS 2.1 or above. z196 hw or above
- No pre-V10 bound packages
- More memory = more performance
- BRF deprecated
- Require BSDS conversion to new format



Thank You