

# IBM System z Technology Summit



## DB2 10 Overview & Migration Planning



# DB2 10 for z/OS: Out-of-the-Box Savings

## CPU reductions for transactions, queries, and batch

- Out-of-the-box CPU reductions of 5-10% for traditional workloads with REBIND
- Up to additional 10% CPU savings using new functions or avoiding constraints
- Out-of-the box CPU reductions of up to 20% for new workloads

## Scales with less complexity and cost

- 5-10x more concurrent users – up to 20,000 per subsystem
- Significant scale-up capabilities in addition to existing scale-out support
- Consolidate to fewer LPARs and subsystems

## Improved operational efficiencies and lower administration cost

- Automatic statistics, diagnostics, tuning, and compression

## Even better performance

- Elapsed time improvement for small LOBS and Complex Queries



# Sample Improvements for Guesstimate

- |  |          |                        |
|--|----------|------------------------|
| ■ Run time CPU reductions                              | 5% - 10% |                        |
| ■ 1 MB page size                                       | 0% - 5%  | z10, z196              |
| ■ Page fix buffers                                     | 0% - 8%  | V8 & high IO, in use?  |
| ■ Release deallocate                                   | 0% - 15% | short trans, batch     |
| ■ Virtual storage constraints                          | 0% - 5%  | memory, latches        |
| ■ Data sharing fewer members                           | 1%       | for each 2 members     |
| ■ Improved dynamic SQL cache                           | 0% - 20% | literals               |
| ■ Insert   | 0% - 40% | high volume insert     |
| ■ Predicate evaluation                                 | 0% - 60% | complex predicates     |
| ■ Access: hash, index include                          | 0% - 5%  | access improved        |
| ■ Increased use of zIIP                                | 0% - 3%  | IO, RUNSTATS, parallel |
| ■ Utilities (from V8)                                  | 3% - 20% | about same for 9 → 10  |
| ■ Productivity: memory, temporal, security, admin, ... |          | priceless              |

## DB2 z/OS Availability Summary

Version	PID	General Availability	Marketing Withdrawal	End of Service
4	5695-DB2	November 1995	December 2000	December 2001
5	5655-DB2	June 1997	December 2001	December 2002
6	5645-DB2	June 1999	June 2002	June 2005
7	5675-DB2	March 2001	March 2007	June 2008
8	5625-DB2	March 2004	September 2009	April 2012
9	5635-DB2	March 2007	December 2012	June 2014
10	5605-DB2	October 2010		

## Some Beta Customer Performance Feedback

Workload	Results
Customer1: Distributed Concurrent Insert	50% DB2 elapsed time reduction; 15% chargeable CPU reduction after enabling high perf DBAT
Customer2: CICS online transactions	Approx. 7% CPU reduction in DB2 10 CM after REBIND, Another 4% reduction with 1MB page usage
Customer3: CICS online transactions	Approx 5% CPU reduction
Customer4: Data sharing heavy concurrent insert	38% CPU reduction
Customer5: Queries	Average CPU reduction 28% from V8 to DB2 10 NFM
Customer6: Batch	Overall 28% CPU reduction after rebind packages
Customer7: DDF OLTP	40% CPU reduction for JDBC stored procedures workload, 15% CPU reduction for securities trading

## Beta Customer Feedback on Selected New Functions

Workload	Results
Multi row insert (data sharing)	33% CPU reduction from DB2 9, 4x improvement from V8 due to LRSN spin reduction
Parallel Index Update	30-40% Elapsed time improvement with class 2 CPU time reduction
Inline LOB	SELECT LOB shows 80% CPU reduction
Include Index	17% CPU reduction in insert after using INCLUDE INDEX
Hash Access	16% CPU reduction comparing Hash Access and Index-data access. 5% CPU reduction comparing Hash against Index only access

# Preliminary Measurements of IBM Relational Warehouse Workload (IRWW) with data sharing

## Base DB2 9 NFM REBIND with PLANMGMT(EXTENDED)

- DB2 9 NFM → DB2 10 CM without REBIND measured 3.7% CPU reduction from DB2 9
- DB2 10 CM REBIND getting same access path measured 7.4% CPU reduction from DB2 9
- DB2 10 NFM measured same 7.4% CPU reduction
- DB2 10 CM or NFM with RELEASE(DEALLOCATE) measured additional 10% CPU reduction from DB2 10 NFM RELEASE(COMMIT)

# Mainframe Innovation: Specialty Engines

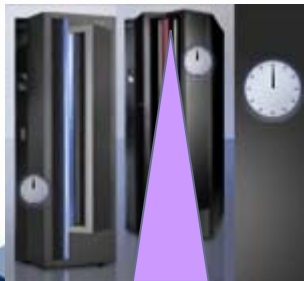

**Internal Coupling  
Facility (ICF) 1997**



**Integrated Facility  
for Linux® (IFL)  
2000**



**System z Application  
Assist Processor (zAAP)  
2004**

## Eligible for zAAP:

- Java execution environment
- z/OS XML System Services



**IBM System z Integrated  
Information Processor and  
(2006)**

## Eligible for zIIP:

- DB2 remote access, XML, large parallel queries, utilities (index, sort, stats)
- ISVs
- IPsec encryption
- XML System Services
- Global Mirror (XRC)
- HiperSockets for large messages (e.g. DRDA)
- IBM GBS Scalable Architecture for Financial Reporting
- z/OS CIM Server
- zAAP on zIIP

\* Statements represent the current intention of IBM. IBM development plans are subject to change or withdrawal without further notice.



# IBM DB2 Analytics Accelerator

- Redirect warehouse-type queries with
  - Query acceleration
  - Consistent response times
- Integrating Netezza technology with DB2 for z/OS
- Application transparency
- Access to data via DB2 for z/OS queries
- Data Studio IDAA administration

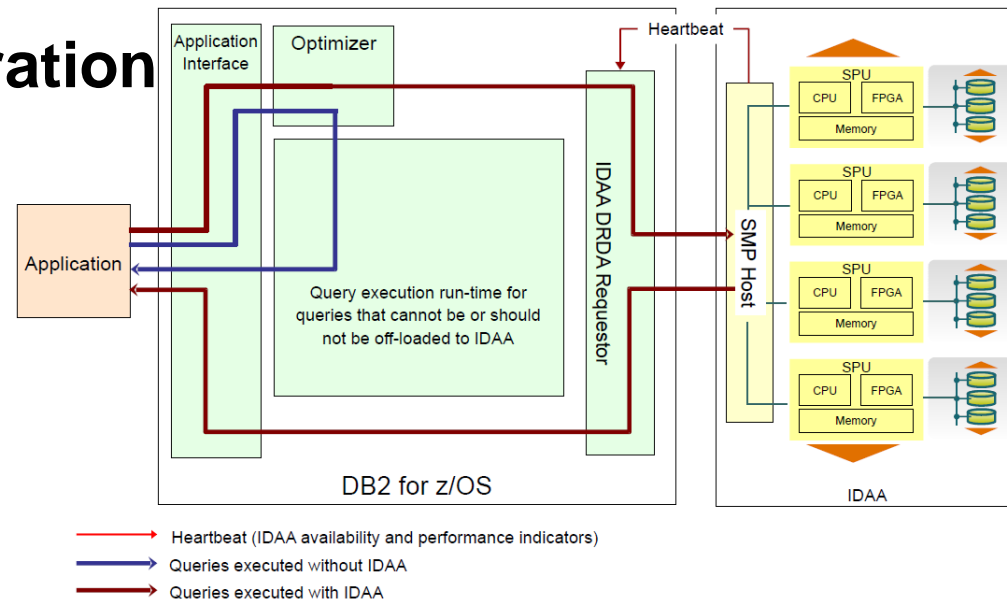

## DB2 & IBM zIIP Add Value to Database Work

Portions of the following DB2 for z/OS V8, DB2 9 and 10 workloads may benefit from zIIP or zAAP for XML (DB2 9 in blue, DB2 10 in green)\*:

### 1 DRDA over TCP/IP connections

- DB2 9 for z/OS Remote Native SQL Procedures
- DB2 9 XML parsing
- XML schema validation
- Increased portion of DRDA redirected to zIIPs to 60%
  - Improved performance via reduced processor switching

### 2 Requests that use parallel queries

- DB2 9 higher percentage of parallel queries zIIP eligible
- DB2 10 more queries eligible, more parallelism

### 3 DB2 Utilities LOAD, REORG & REBUILD functions used to maintain index structures and sort

- DB2 10 RUNSTATS
  - options other than column group
  - not for inline stats

### 4 DB2 10 buffer pool prefetch and deferred write

## Performance Enhancements Few Changes (CM)

- **SQL runtime improved efficiency**
- **Address space, memory changes to 64 bit, some REBINDs**
- **Faster single row retrievals via open / fetch / close chaining**
- **DB2 9 utility enhancements in CM8**
- **Parallel index update at insert**
- **Workfile in-memory enhancements**
- **Index list prefetch**
- **Buffer pool enhancements**
  - Utilize 1MB page size on z10
  - “Fully in memory” option (ALTER BUFFERPOOL)

# Performance Enhancements need REBIND (CM)

- **Most access path enhancements**
- **Further SQL runtime improvements**
- **Use of RELEASE(DEALLOCATE)**
- **SQL paging performance enhancements**
  - Single index access for complex OR predicates:
- **IN list performance**
  - Optimized Stage1 processing (single or multiple IN lists)
  - Matching index scan on multiple IN lists
- **Safe query optimization**
- **Query parallelism improvements**
- **More stage 2 predicates can be pushed down to stage 1**
- **More aggressive merge of views and table expressions**
  - Avoid materialization of views
- **If migrating from V8, get new RUNSTATS before mass rebind**

## **Performance Enhancements requiring NFM**

- **DB2 catalog concurrency and productivity**
- **Compress on insert**
- **Most utility enhancements**
- **LOB streaming between DDF and rest of DB2**
- **Faster insert, lower virtual storage consumption**
- **SQL Procedure Language performance improvements**
- **Workfile spanned records, partition by growth**
- **Access to currently committed data**
- **Insert improvement for universal table spaces**
- **Improvement for multirow insert**
- **Efficient caching of dynamic SQL statements with literals**

# Performance Enhancements need NFM + DBA

- **Hash access path**
  - Create + Reorg + rebind to activate
- **Index include columns**
  - Alter + Rebuild + rebind to activate
- **Inline LOBs**
  - Alter (need universal table space and reordered row format)
- **DEFINE NO for LOB and XML columns**
- **MEMBER CLUSTER for Universal Table Space**
  - Alter + Reorg
- **Alter to universal table space, page size, data set size, segment size**
  - Alter + Reorg
- **Online reorg (SHRLEVEL CHANGE) for all catalog and directory table spaces**

# Hashing Summary



- **Provides fast, direct location of most rows**
  - Reduces I/O and CPU in most cases
  - Can replace an existing Primary or Unique Key Index
    - Faster Insertion/Deletion
- **Size of Fixed Size Hash Area is important**
  - Too small and performance degrades, too large and space is wasted
- **DB2 helps you manage the size**
  - REORG AUTOESTSPACE YES
  - RTS tracks the number of overflowed entries
- **If clustering is important for query performance, then be aware that Hash will eliminate these benefits**
- **LOAD performance is slower with hash**

# Best practice for hash INDEX on AcctID

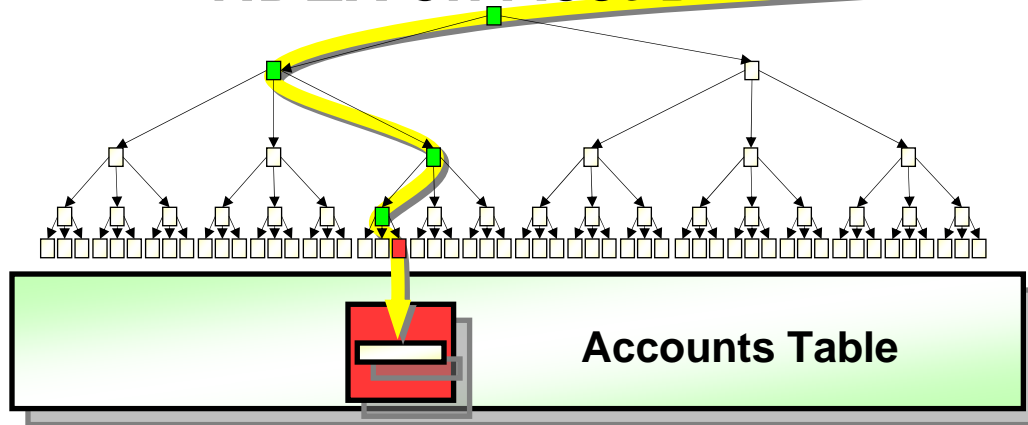

Select Balance  
From Accounts  
WHERE acctID = 17

■ Page in Bufferpool  
■ Page Read from Disk

- ❑ Table has a unique key. Queries are equal predicates on unique values to return a single row of data
- ❑ Most access to the data in the table is truly random, no need for clustering
- ❑ Size of data in the table is relatively stable, or the maximum size is known
- ❑ Many rows fit on a single data page.
- ❑ Rows of relatively uniform size.
- ❑ Index on the table's unique key would have more than 3 levels, not index only
- ❑ Monitor real time statistics to ensure that hash access is used, and tune the size of the hash space.



# Virtual storage improvements

- **DBM1 below 2GB**
  - 75-90% less usage in DB2 10 compared to DB2 9
  - Some of working storage (stack, xproc storage) stays below 2GB
- **Larger number of threads**
  - Possible data sharing member consolidation
- **Improve CPU with storage**
  - More release deallocate



## DB2 10

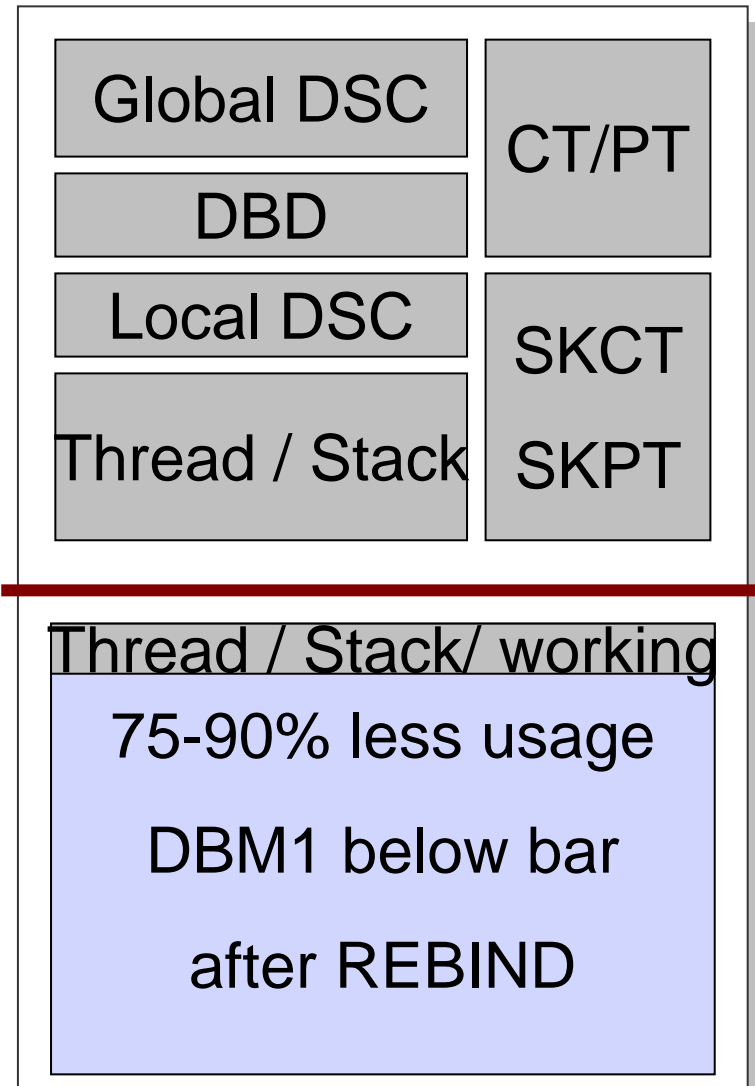

# Running Many Active Threads

Today

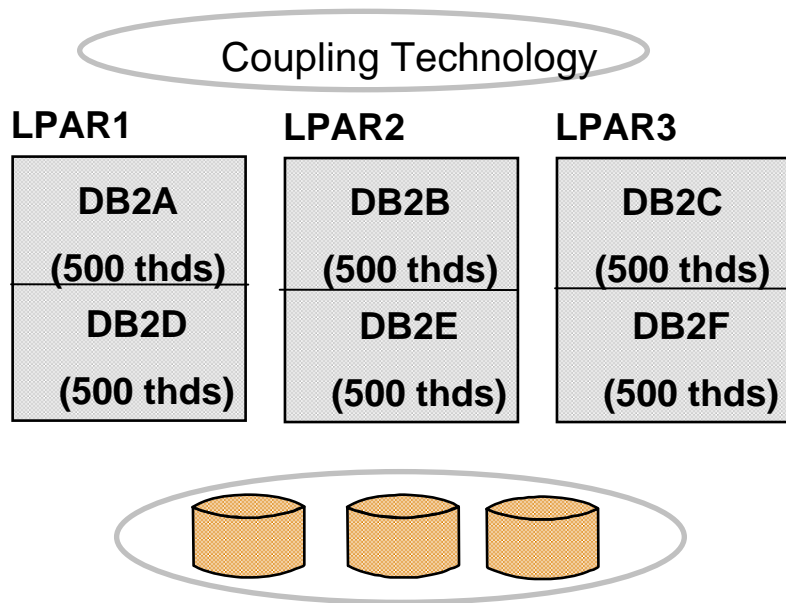

DB2 10

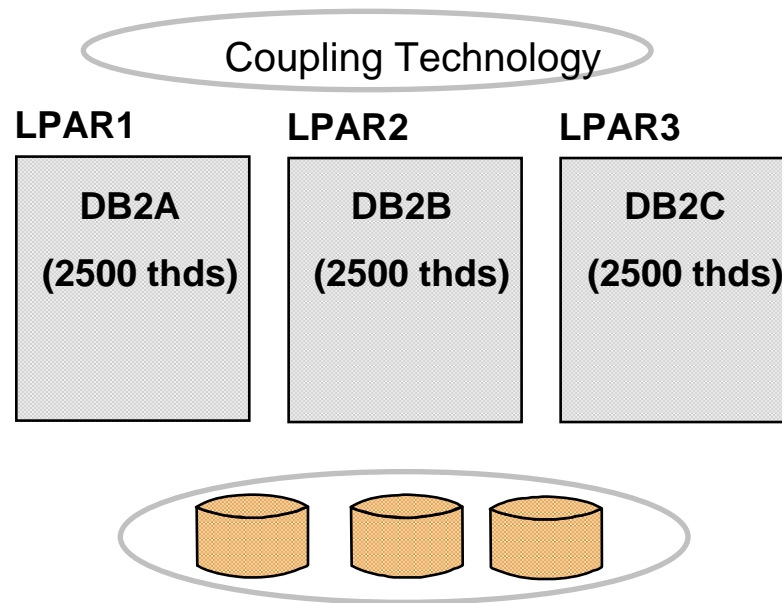

- Data sharing and sysplex allows for efficient scale-out of DB2 images
- Sometimes multiple DB2s per LPAR

- More threads per DB2 image
- More efficient use of large n-ways
- Easier growth, lower costs, easier management
- Data sharing and Parallel Sysplex still required for very high availability and scale
- Rule of thumb: save ½% CPU for each member reduced, more on memory

## Other System Scaling Improvements

- **Other bottlenecks can emerge in extremely heavy workloads**
  - several improvements reduce latching and other system serialization contention
  - new option to for readers to avoid waiting for inserters
  - eliminate UTSERIAL lock contention for utilities
  - Use 64-bit common storage to avoid ECDSA constraints
- **SPT01 64GB limit can be a constraint, especially if package stability is enabled**
  - Allow many more packages by using LOBs
  - COMPRESS\_SPT01 still available
- **Improved accounting rollup, compress SMF option**

## Major changes in DB2 10 catalog & directory

- **Improve availability and productivity**
- **Increase maximum size substantially**
- **Reduce contention: BIND, DDL, utilities**
- **Catalog changes: Remove links**
  - Many more table spaces, partition by growth
  - Row level locking, reordered row format
  - CLOB and BLOB columns for long strings
    - Inline for performance
  - Online reorganization and check
  - More automatic: DB2-managed SMS-controlled

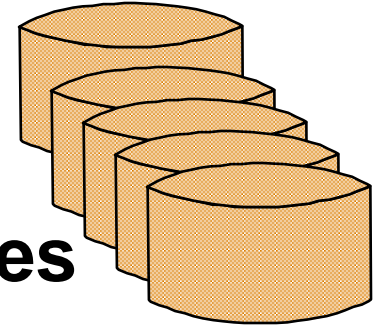

# Improved availability ALTER REORG

Pending ALTER, then online REORG to make changes

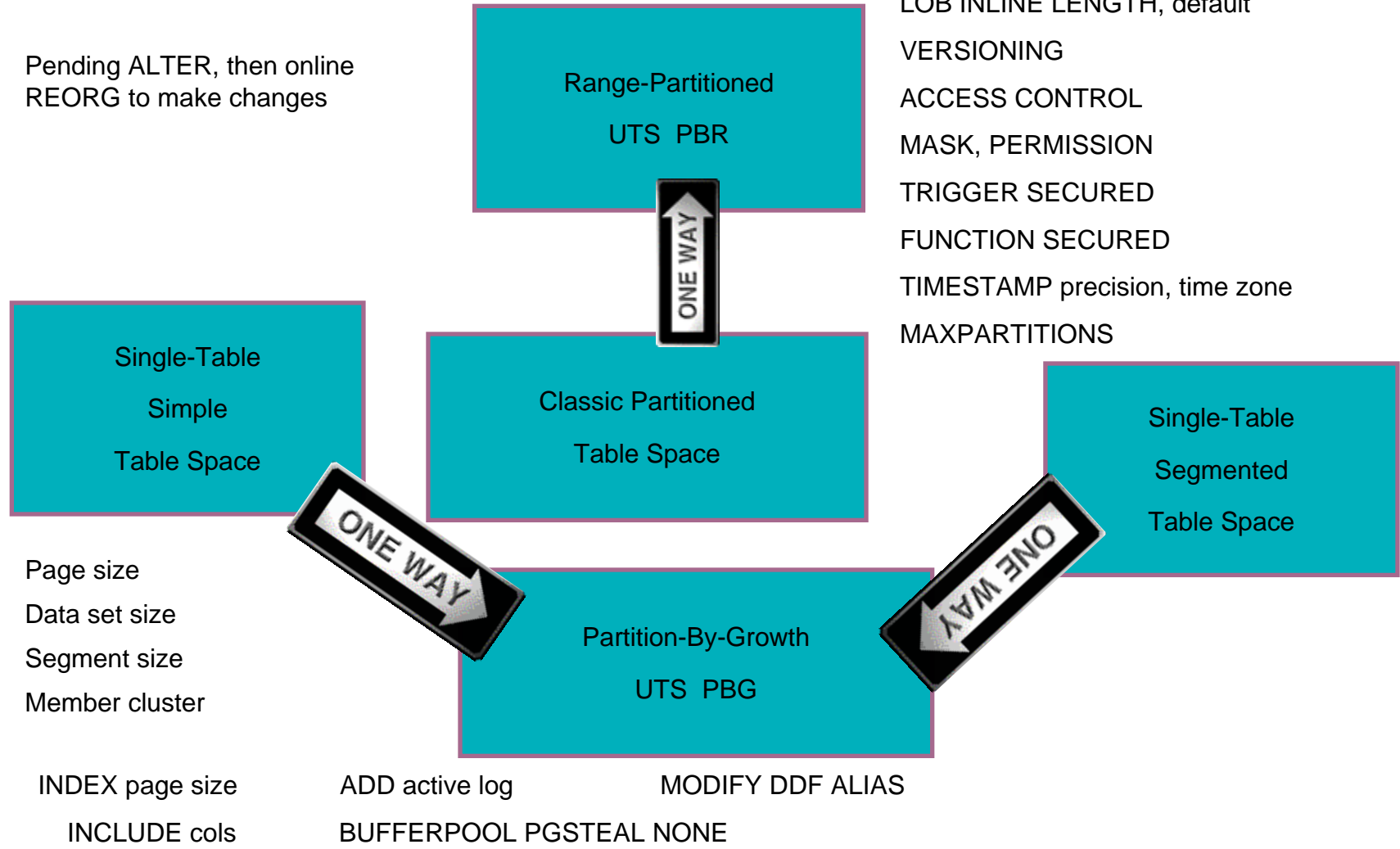

# Business Security & Compliance

- Protect sensitive data from privileged users & improve productivity
  - SECADM & DBADM without data access
  - Usability: DBADM for all DB
  - Revoke without cascade
- Separate authorities to perform security related tasks, e.g. security administrator, EXPLAIN, performance monitoring and management
- Audit privileged users
- Row and column access control
  - Allow masking of value
  - Restrict user access to individual cells



## DB2 10: Productivity – Doing More with Less!

- Easier performance & scaling, simpler memory management
- Reduce contention, more online processing
- Reduced need for REORG
- Auto statistics collection
- Monitoring enhanced

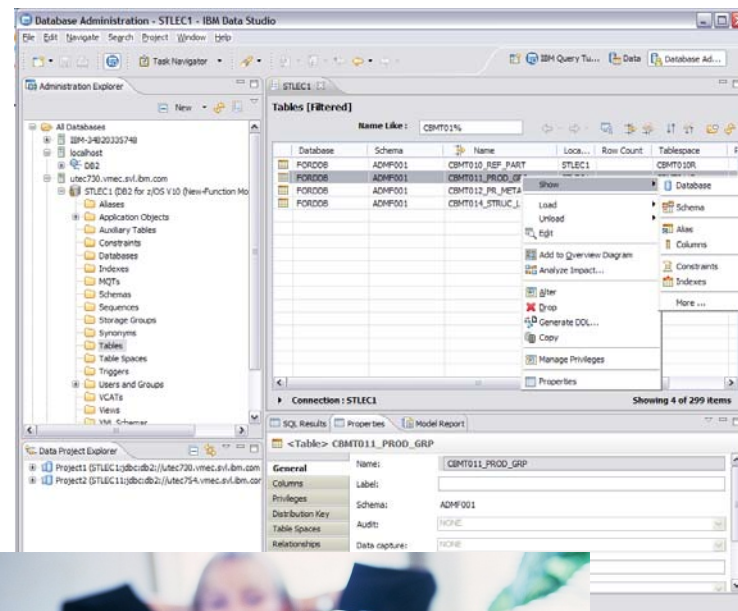

## DB2 10 Utilities Enhancements

- REORG SHRLEVEL(CHANGE) for LOBs
- Online REORG enhancements
  - SHRLEVEL(CHANGE) for all catalog & directory
  - Option to cancel blocking threads
- Improved usability & availability
  - Allow disjoint partition ranges
  - Permit movement of rows between partitions when LOB columns exist
    - Allow REBALANCE and ALTER LIMITKEY even when LOB columns exist
    - Allow DISCARD to delete associated LOB values
  - Messages to estimate length of REORG phases and time to completion



# Query Processing Enhancements

## ■ Performance Improvements

- Improved caching of dynamic SQL with literals
- Safe Query Optimization
- Aggressive View Merge
- IN List Processing
- SQL Pagination
- Parallelism Enhancements

## ■ Access Path Stability

- Relief from package REBIND regression
- Access Path Repository (BIND QUERY)



# Query Enhancements

- **CPU time reductions for queries, batch, & transactions**
  - Complex predicate processing improvements
- **SQL enhancements: Moving Sum, Moving Average, temporal, timestamp, implicit cast, SQL PL, ...**
- **pureXML improvements (MV storage)**
- **Access improvements: Index include columns, Hash**
- **Optimization techniques**
  - Remove parallelism restrictions; more even parallel distribution
  - Scalability: memory and latching relief allow more parallel
  - Increased zIIP use – parallel, prefetch, RUNSTATS
  - In-memory techniques for faster query performance
- **Analysis: instrumentation, Data Studio & Optim Query Tuner**

## DB2 10 Application Enablement and Portability

- **Data versioning by date**
- **pureXML enhancements – Basic XQuery support**
- **Large object improvements**
  - Allow non-NULL default values for inline LOBs
  - Loading and unloading tables with LOBs
    - LOBs in input/output files with other non-LOB data
- **Improved portability and SQL consistency**
  - Currently committed locking semantics
  - Implicit casting or loose typing
  - Timestamp with time zone
  - Variable timestamp precision – seconds to picoseconds
  - Moving Sum, Moving Average, and others...

## Versioned data or Temporal Data

- **Table-level specification to control data management based upon time**
- **Two notions of time:**
  - System time: notes the occurrence of a data base change
    - “row xyz was deleted at 10:05 pm”
    - Query at current or any prior period of time
    - Useful for auditing, compliance
  - Business time: notes the occurrence of a business event
    - “customer xyz’s service contract was modified on March 23”
    - Query at current or any prior/future period of time
    - Useful for tracking of business events over time, application logic greatly simplified
- **New syntax in FROM clause to specify a time criteria for selecting historical data**



## **pureXML improved performance & usability**

- XML schema validation in the engine for improved usability and performance
- Binary XML exchange format improves performance
- XML multi-versioning for more robust XML queries
- Allow easy update of XML document nodes
- Stored procedure, UDF, Trigger enhanced support
- XML index matching with date/timestamp
- CHECK DATA utility checks XML
- Basic XQuery support

**Jump into DB2 10! The water's fine.**



**DB2 V8**

**DB2 9**

**DB2 10**

**Key Questions are WHEN? and HOW?**



# DB2 10 for z/OS: Skip-Level Migration

- May move from V8 to DB2 10
- Migration, fallback and data sharing coexistence fully supported
  - Mix of DB2 9 and 10 or DB2 V8 and 10
  - Once a migration path is started....it is committed
- Key considerations:
  - V8 EOS & DB2 9 EOS Date is negating most of this conversation
  - Risk/reward analysis
    - What's your risk? Tolerance level?
    - How will you do it? What's your mitigation plan? Are ISVs ready?
    - What workloads do you need to test and can you test them properly?
    - Do you have best practice service and test processes?
  - Migration cost savings is not 2X versus two migrations
    - Migration considerations for two versions still apply
    - Larger migration project, longer migration timeline
    - Applications and ISVs need to be ready
  - DB2 10 NFM features are NOT available until DB2 10 NFM

# Prerequisite Summary & Planning

- **z/Architecture (z890, z990, z9, z10, z196)\***
- **Configure a minimum of**
  - 128GB of shared private - HVSHARE (V9)
  - 6GB of shared extended private – HVCOMMON (V10)
- **z/OS 1.10 or above**
  - Some features require z/OS V1.11
- **Migrate from**
  - DB2 for z/OS V8 NFM
  - DB2 9 for z/OS NFM
  - With Fallback SPE (PK56922)
- **Coming from V8**
  - BSDS reformatted for larger active / archive tracking
  - Check use of Java drivers





# Prerequisite Summary & Planning

- **Run a current DSNTIJPA pre-migration job**
  - **PM33991 / PM15965 / PM30748 / PM48451 / PM47246 / PM54699**
  - **35 Reports**
- **Check Tools / Purchased Applications**
- **Establish performance benchmarks**
- **Eliminate use of Private Protocol & DBRMs bound into Plans**
  - Consider using PRIVATE\_PROTOCOL=NO on V8 or 9
  - See PM17665 / PM37300 for Plan Ownership Authorization
    - PRIVATE\_PROTOCOL=AUTH for relief in V8, 9, or 10
- **Upgrade EXPLAIN table formats to most current in UNICODE (DSNTIJXA, DSNTIJXB, DSNTIJXC)**



# Prerequisite Summary & Planning

## ▪ Check Incompatibilities

- Installation Guide
- Application Programming Guide
- Check programming language requirements

## ▪ Resolve incompatible changes

- Timestamp format YYYY-MM-DD-HH:MM:SS.mmmmmm
- No more extenders
- No more Optimization Service Center or Book Manager
- REORG LOB SHRLEVEL NONE



# Prerequisite Summary & Planning

- **SMS managed catalog and directory**
  - DSNTIJSS provided as a sample for configuration
    - A copy of [DSNTIJSS](#) can be obtained from developerWorks
      - Search for file dsntijss.copy
  - Data Class with Extended Addressability and Extended Format
- **PDSEs required for SDSNLOAD, SDSNLOD2, ADSNLOAD**
- **Build a detailed migration plan**
- **Assess the training plans for your organization**



# Prerequisite Summary & Planning

- **Don't spend your savings before they are realized**
  - 10 – 30% more real storage
  - DB2 10 BVA for sub-capacity licensing
- **REBIND in CMx**
  - Use Plan Management
    - If migrating from DB2 9; possible APREUSE, APCOMPARE, or APRETAINDUP
  - RUNSTATS before REBIND for migrations from V8
- **Use a proactive PMR**
  - Particularly CMx in Production
- **How will you execute your plan?**
  - CM8 or CM9 or for Conversion Mode / Coexistence
    - X Mode for Coexistence
  - EN8 or EN9 for Enable New Function Mode
  - NFM



# DSNTXAZP (Job DSNTIJXZ)

- Job to update the installation CLIST input (DSNTIDxx) to reflect current:

- System parameters
- Buffer pool settings

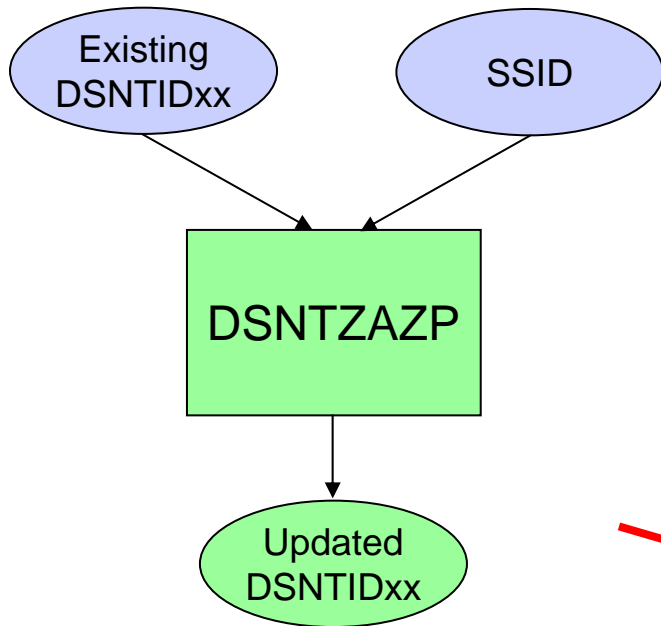

CLIST INPUT MEMBER GENERATION REPORT \*\* 2010-05-21 06:28:18

CLIST PARAMETER REPORT:

```

0001 PARAMETER NAME           = ABEXP
    ZPARAM/BUFFERPOOL PARAMETER = ABEXP
    PARAMETER TYPE              = CHAR
    DATA SHARING SCOPE        = M
    MINIMUM VALUE               = NO
    MAXIMUM VALUE               = YES
    CURRENT CLIST VALUE         = YES
    CURRENT INSTALLED VALUE     = YES
    STATUS                       = RETAINED
  
```

```

0030 PARAMETER NAME           = AUDIT
    ZPARAM/BUFFERPOOL PARAMETER = AUDITST
    PARAMETER TYPE              = CHAR
    DATA SHARING SCOPE        = M
    MINIMUM VALUE               = NONE
    MAXIMUM VALUE               = NONE
    CURRENT CLIST VALUE         = YES
    CURRENT INSTALLED VALUE     = 1
    STATUS                       = UPDATED
  
```

CHANGE SUMMARY REPORT:

CLIST PARAMETER NAME	ZPARAM/BUFFERPOOL NAME	VALUE
ABEXP	-SAME-	YES
ASSIST	-SAME-	NO
* AUDIT	AUDITST	1 (YES)

# DB2 10 Project Planning Framework Structure

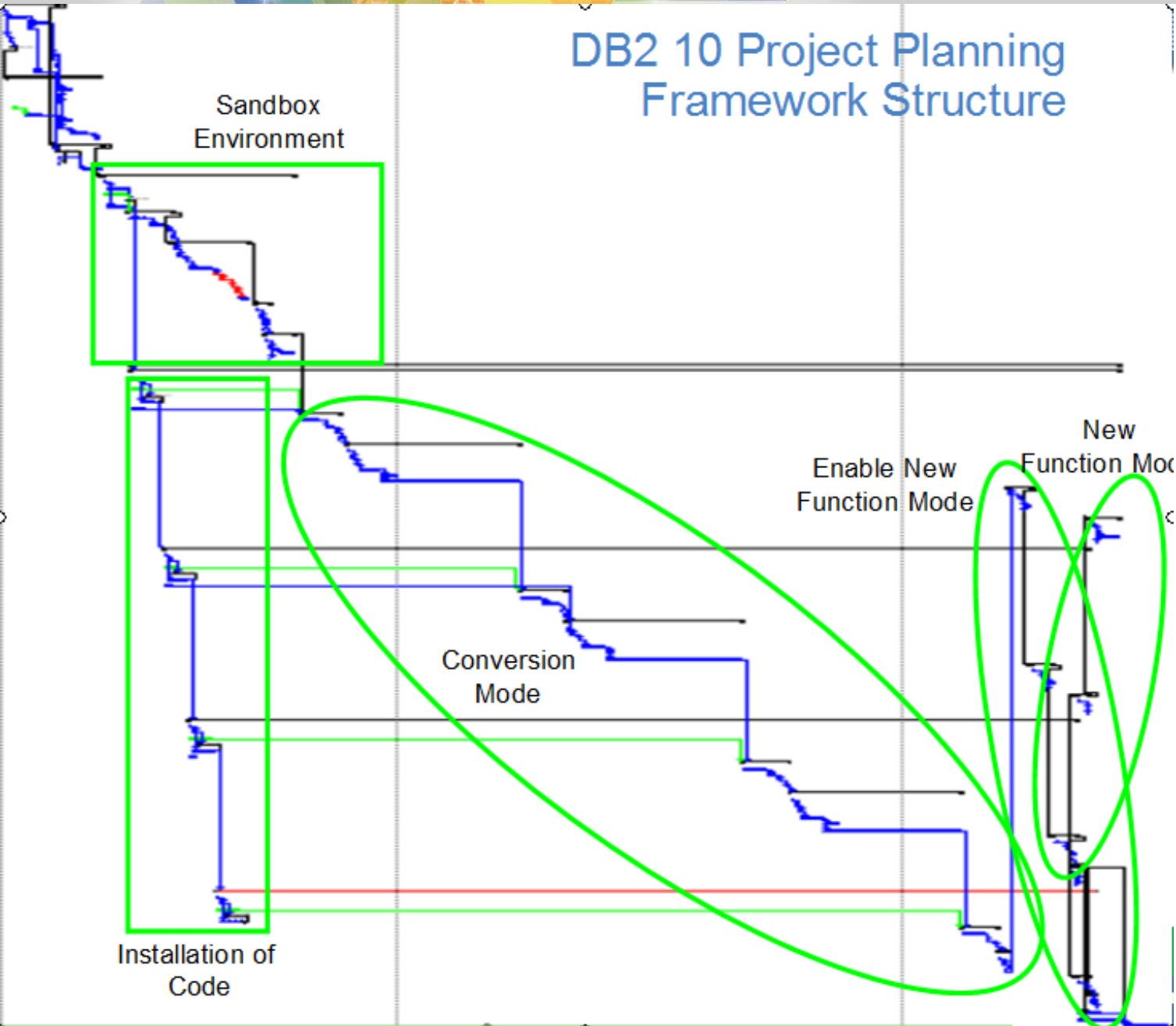

# Free Migration Planning Workshops DB2 10 9

- Understand breadth of features in DB2 for z/OS
- Bring together a toolbox of resources for your migration planning
- Explain the current migration process
- Bring a project focus to migration
- Remain relevant through GA life of the product
  - Updated with field experiences



# Important features of information center

- Find helpful usage instructions in the “Information center home” section.
- Easily send feedback by clicking the Feedback link at the bottom of any topic.
- Conveniently download the PDF version of the information from the link at the bottom of any topic. *(Look for the PDF icon!)*

The screenshot displays the IBM Information Center interface for 'DB2 10 for z/OS information'. The top navigation bar includes links for Home, Business solutions, IT services, Products, Support & downloads, and My IBM. A search bar is present with the text 'Search scope: ten'. The left sidebar shows a tree view of the information center structure, including sections like 'Information center home', 'Data warehousing and analytics', and 'DB2 10 for z/OS' with various sub-topics.

The main content area is titled 'DB2 10 for z/OS information' and contains the following text:

Welcome to the DB2® 10 for z/OS® (DB2 for z/OS) information, where you can find topics that you need to use DB2 for z/OS. By using this information, you can install or migrate to Version 10 of DB2 for z/OS, develop and run application programs, and administer and operate DB2 databases and subsystems.

These topics can also be found in DB2 for z/OS PDF books. To see the correspondence between the PDF books and the information center topics and to download PDF books, view this table.

Subscribe to DB2 10 for z/OS information updates

The 'Resources' section is organized into several columns:

- Getting started:** Planning for Version 10, DB2 for z/OS information roadmap, What's new in the information center.
- News and events:** News about DB2 for z/OS, Upcoming DB2 for z/OS events.
- Programming with DB2:** Application programming and SQL, Programming for Java™, Programming for ODBC, Programming for XML with DB2.
- IBM® Information Management training:** DB2 for z/OS training, Professional certification.
- General product information:** DB2 for z/OS home page, Terminology and citations, Accessibility for DB2.
- DB2 administration:** Administration, Data sharing, Managing performance.
- Communities:** DB2 for z/OS Exchange, developerWorks Information Management forums, International DB2 User Group (IDUG®), Information Management user groups, SHARE.
- Related information:** IBM Redbooks™, IBM Publications Center, IBM Information Centers.

The right-hand sidebar contains two sections:

- Support and assistance:** Send feedback, Search for messages and codes, DB2 for z/OS Support, DB2 developerWorks site, DB2 for z/OS downloads, Information Management Business Partner Solutions, IBM Global Solutions directory, Survey: Quality technical information.
- Using the information center:** Navigating, Searching, Setting bookmarks, Printing topics, Displaying information in your preferred language, Accessibility.

At the bottom of the page, there is a footer with the following text:

Terms of use | Library | Support | Feedback  
[https://publib.boulder.ibm.com/infocenter/dzichelp/v2r2/topic/com.ibm.db2z10.doc/db2z\\_10\\_prodhome.htm](https://publib.boulder.ibm.com/infocenter/dzichelp/v2r2/topic/com.ibm.db2z10.doc/db2z_10_prodhome.htm)  
 Last updated: December, 2010



# IBM DB2 Tools: Are you ready for DB2 10?

- Exploit DB2 10 performance savings out-of-the-box
- Optimize Performance Across Multi-Platform Applications
- Lower CPU costs while reducing batch windows
- Higher data availability through simplified recovery operations



## All New with DB2 10!

**DB2 Utilities Suite 10** drives down costs with autonomics, page sampling and further offloads processing to zIIPs and FlashCopy. Developed in conjunction with DB2 10 to provide maximum data integrity and exploit all new functions out of the box.

**DB2 Administration Tool/Object Compare 10.1** extends the value of DB2 10 with new capabilities that allow DBAs to quickly exploit DB2 10 features like schema evolution. Reduces the overhead of many routine tasks.

**DB2 Sort 1.1** lowers the cost of DB2 Utility sort processing by exploiting advanced features of System z and z/OS while optimizing overall system efficiency. Significantly reduces batch windows.

**Tivoli OMEGAMON XE for DB2 Performance Expert 5.1** extends its insight into distributed workloads and offers a robust infrastructure to support DB2 10 subsystem consolidation, with lower monitoring overhead.

The recommended performance monitor of DB2 10!

**QMF 10** delivers built-in visualizations and reports that dramatically extend the value to end users.

A new metadata layer simplifies the process to understand and create reports.

**DB2 High Performance Unload 4.1** reduces the cost of extracting DB2 10 data with support for TCP/IP Pipes and the new internal format as well as a new native XML data unload capability.

# DB2 9 and 10 **IBM Redbooks** Publication

1. DB2 10 Technical Overview SG24-7892 new
2. Extremely pureXML DB2 10 & 9 SG24-7915 new
3. DB2 10 Performance Topics coming soon
4. DB2 9 Technical Overview SG24-7330
5. DB2 9 Performance Topics SG24-7473
6. DB2 9 Stored Procedures SG24-7604
7. Serialization and Concurrency SG24-4725-01
8. Distributed Functions SG24-6952
9. Utilities SG24-6289-01
10. DB2 and Storage Management, SG24-7823
11. Index Compression with DB2 9 for z/OS redp4345
12. SQL Reference for Cross-Platform Development
13. Enterprise Database Warehouse, SG24-7637
14. 50 TB Data Warehouse on System z, SG24-7674
15. LOBs with DB2 for z/OS SG24-7270
16. Deploying SOA Solutions SG24-7663
17. Enhancing SAP - DB2 9 SG24-7239
18. Best practices SAP BI - DB2 9 SG24-6489-01
19. Data Sharing in a Nutshell, SG24-7322
20. Securing DB2 & MLS z/OS SG24-6480-01
21. Data Sharing: Dist Load Balancing & config. redp4449
22. Packages Revisited, SG24-7688
23. Ready to Access Solid-State Drives redp4537
24. Buffer Pool Monitoring & Tuning redp4604
25. ...

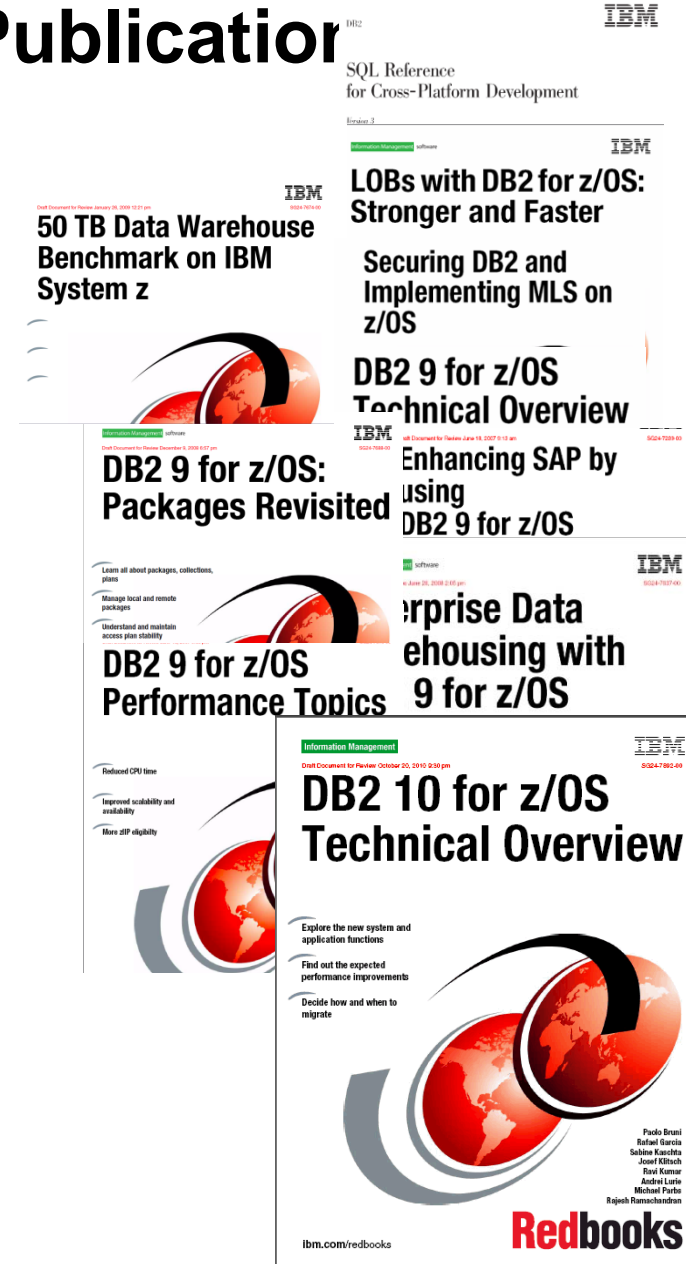

## More information and resources

- **DB2 main web page**  
<http://www.ibm.com/software/data/db2/zos/>
- **DB2 10 web page**  
<http://www.ibm.com/software/data/db2/zos/db2-10/>
- **DB2 books, Information Center**
  - <http://www.ibm.com/support/docview.wss?rs=64&uid=swg27011656>
  - <http://publib.boulder.ibm.com/infocenter/imzic>
- **DB2 best practices web page**
  - <https://www.ibm.com/developerworks/data/bestpractices/db2zos/>
- **DB2 for z/OS IBM Redbooks publications**
  - <http://www.redbooks.ibm.com/cgi-bin/searchsite.cgi?query=db2&SearchOrder=4&SearchFuzzy=>
- **DB2 presentations**  
<ftp://ftp.software.ibm.com/software/data/db2/zos/presentations/>
- **DB2 for z/OS Exchange Forum**  
<https://www.ibm.com/developerworks/mydeveloperworks/groups/service/html/communityview?communityUuid=22586cb0-8817-4d2c-ae74-0ddcc2a409bc>

Information Management

IBM

IBM Software Group

DB2 10 for z/OS  
Proven, simplified and cost effective

DB2 10 for z/OS  
Technical Overview

Explore the new system and application functions

Obtain information about expected performance improvements

Decide how and when to migrate to DB2 10

IBM

Information Management

IBM

Draft Document for Review January 9, 2011 1:25 pm

SQ24-7915-00

Extremely pureXML  
in DB2 10 for z/OS

Triton  
CONSULTING

Information Management

IBM

Draft Document for Review February 25, 2011 11:01 am

SQ24-7942-00

DB2 10 for z/OS  
base for a Smarter Planet

DB2 10 for z/OS  
Performance Topics

Discover the functions that provide reduced CPU time in CM and NFM

Thank  
YOU