



**zEnterprise –
An Ideal Basis For
Smarter Computing**

System z – Still The Best Place For Data

Businesses Analytics Answers Key Questions That Drive A Competitive Edge

How are we doing?

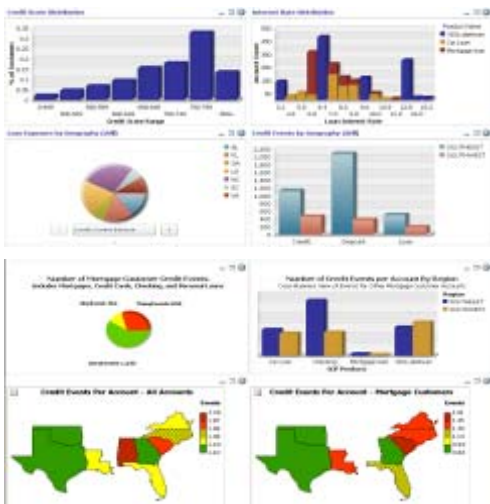

Dashboard
Operational or Strategic

Why are we on/off track?

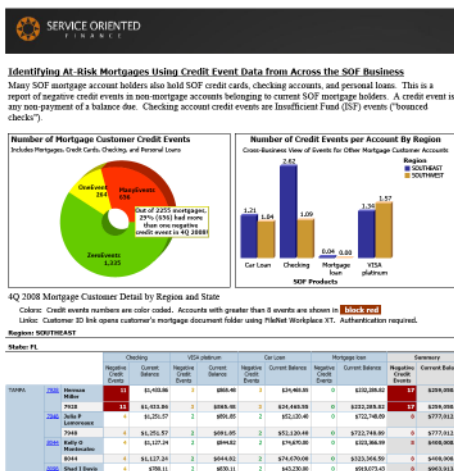

Query and Reporting
Exploratory Analysis

What should we do next?

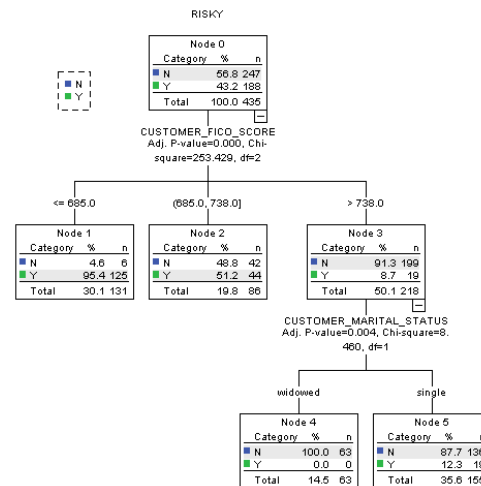

Analytics
Statistics and Predictive Analytics



Executive



Business Manager



Casual Business User



Line Manager



Business Analyst



Financial Analyst

Businesses Benefit By Using An Analytic Approach Over Intuition



40% decline
in homicide rates



600% increase
in cross-sell
campaign



\$13.8 Million
in cost savings



PRIMERICA
1000's of Reps
run their daily business using
IBM Business Analytics



80% decrease
in reporting time on top of
Oracle e-business suite

OmnicomGroup



\$200 Million
increase in cash flow

The more analytics a business uses, the better it performs

There Are Two Approaches To Analytics

Operational Business Intelligence

Simple Queries

“How are we doing?”

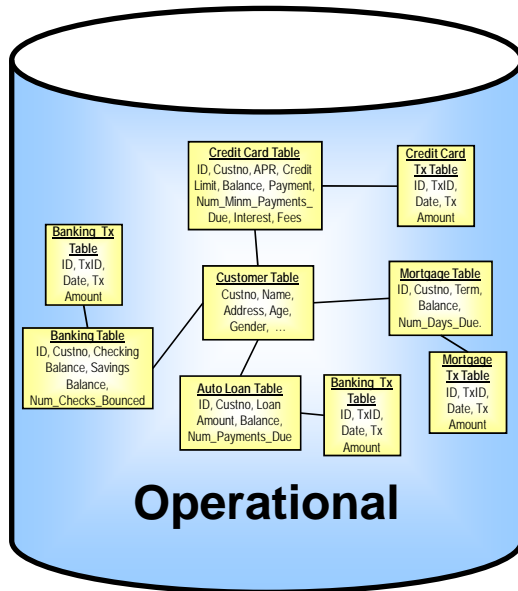

Schema organized to efficiently process simple queries
No Duplicated Data

Deep Analytics

Longer Queries

“Why?”

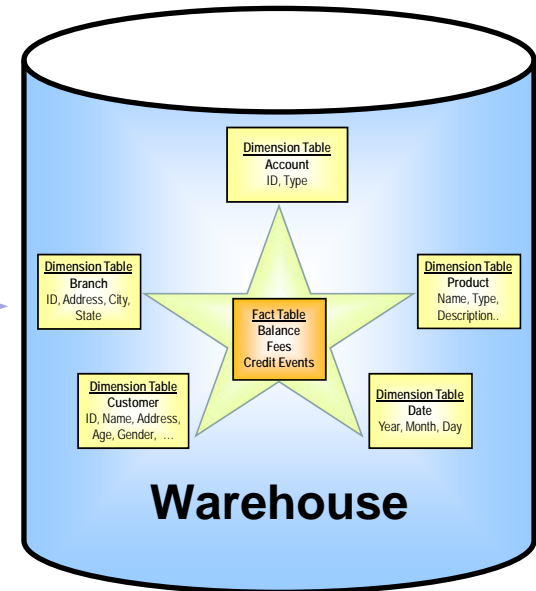

Schema organized to efficiently answer longer queries
Data is Duplicated



Transform Schema

Operational Business Intelligence Answers Simple Questions Quickly

■ Advantages

- ▶ Technologies designed for fast OLTP also work well for simple operational BI queries
- ▶ Access most recent data with real-time queries
- ▶ Does not require Extract-Cleanse-Transform-Load processes
- ▶ No requirement to duplicate the data

■ Considerations

- ▶ Can impact OLTP performance

Demo: Use Dashboards To Answer The Question “How Are We Doing?”

■ Dashboards give quick access to information

- ▶ Present at-a-glance, high impact views of relevant scorecards and information
- ▶ Use visual indicators such as gauges and dials
 - Drill-down into details
- ▶ No additional licensing requirements to create dashboards with Cognos BI

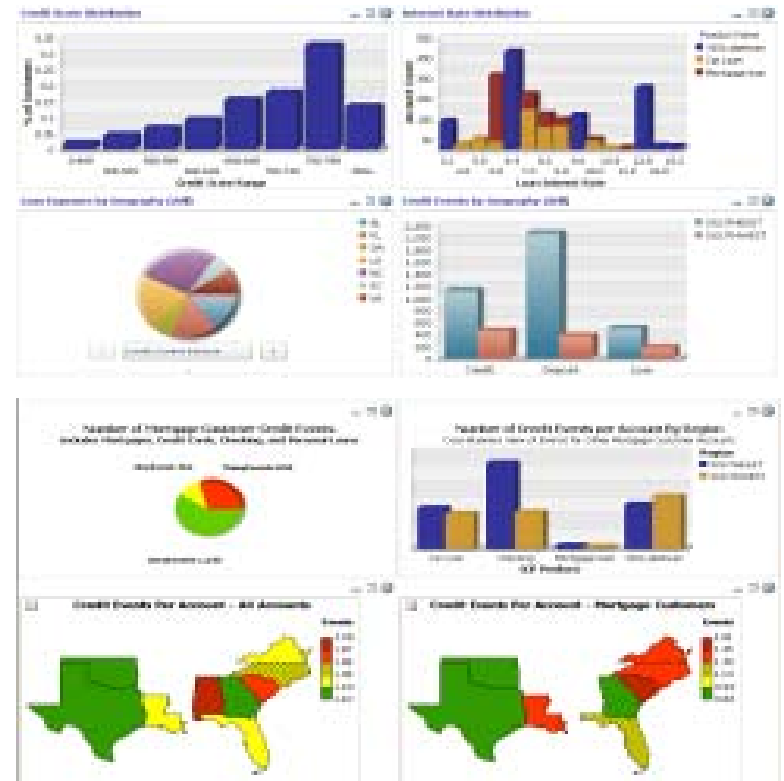

Deep Analytics Answers Deeper Questions

- Access historical data
- Use Extract-Cleanse-Transform-Load to unify customer information across OLTP silos into a Warehouse
- Queries are complex and long running
- Scan millions of records to compute aggregations
- Unique technologies to speed up complex queries

Operational Data Typically Stored In A Schema Designed For Fast Access To Small Amounts Of Data

```
SELECT Cust_Name, Monthly_Pymt FROM Customer,  
Mortgage WHERE Cust_No = '7928'
```

| Customer Table | | | | |
|----------------|---------------|-------------|----------|------|
| Cust No | Cust Name | Cust Gender | Cust Age | |
| 7928 | Herman Miller | M | 29 | ... |
| 8010 | Hyong X Nolan | M | 22 | ... |
| ... | ... | ... | ... | ... |

| Mortgage Table | | | | |
|----------------|---------|------|--------------|------|
| ID | Cust No | Term | Monthly Pymt | |
| LF236 | 7928 | 15 | 2263.09 | ... |
| LF318 | 8010 | 15 | 9432.96 | ... |
| ... | ... | ... | ... | ... |

Complete View Requires Joining Many Tables

| Customer Table | | | | |
|----------------|---------------|-------------|----------|------|
| Cust No | Cust Name | Cust Gender | Cust Age | |
| 7928 | Herman Miller | M | 29 | ... |
| 8010 | Hyong X Nolan | M | 22 | ... |
| ... | ... | ... | ... | ... |

| Mortgage Table | | | | |
|----------------|---------|------|--------------|------|
| ID | Cust No | Term | Monthly Pymt | |
| LF236 | 7928 | 15 | 2263.09 | ... |
| LF318 | 8010 | 15 | 9432.96 | ... |
| ... | ... | ... | ... | ... |

| Car Loan Table | | | | |
|----------------|---------|------|--------------|------|
| ID | Cust No | Term | Monthly Pymt | |
| CL12 | 7928 | 35 | 463.05 | ... |
| CL38 | 8010 | 60 | 432.87 | ... |
| ... | ... | ... | ... | ... |

| Credit Card Table | | | | |
|-------------------|---------|--------|------------|------|
| ID | Cust No | APR | Minm. Pymt | |
| CC25 | 7928 | 12.99% | 299 | ... |
| CC97 | 8010 | 5.99% | 599 | ... |
| ... | ... | ... | ... | ... |

Data Warehouses Organize Data Differently For Efficient Comprehensive View

See All Activity For A Given Customer

| FACT Table | | | | | | |
|------------|---------|---------|---------|------|---------------|------|
| CustNo | Acct_ID | Date_ID | Payment | Term | Credit_Events | |
| 7928 | LF236 | 365 | 2263.09 | 15 | 0 | ... |
| 7928 | CF12 | 365 | 463.05 | 35 | 3 | |
| 7928 | CC25 | 365 | 299 | NULL | 3 | |
| ... | ... | ... | ... | | | ... |

DB2 For z/OS Is Optimized For Operational BI Queries

- Workload Management (WLM) optimizes resource sharing between OLTP and Analytical Queries
 - ▶ Minimize impact on OLTP performance
- Cost Based Optimizer provides best access path and query execution plan
- Achieves Near-Linear Scaling And High Availability with Parallel Sysplex Clustering
- Provides Hash access path for even faster access to a single row of a table
- DB2 10 supports up to 10x more concurrent users and up to 20,000 concurrent connections per subsystem

A Large US Financial Institution - Performance Comparison Of Operational BI

1.2X More
Small Reports

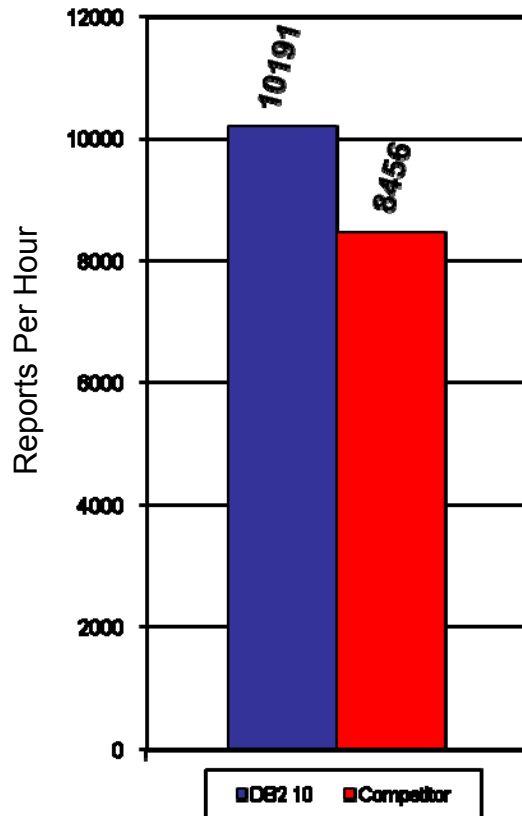

Reports Per Hour
at 750GB data size
(Higher is Better)

3.2X More
Medium Reports

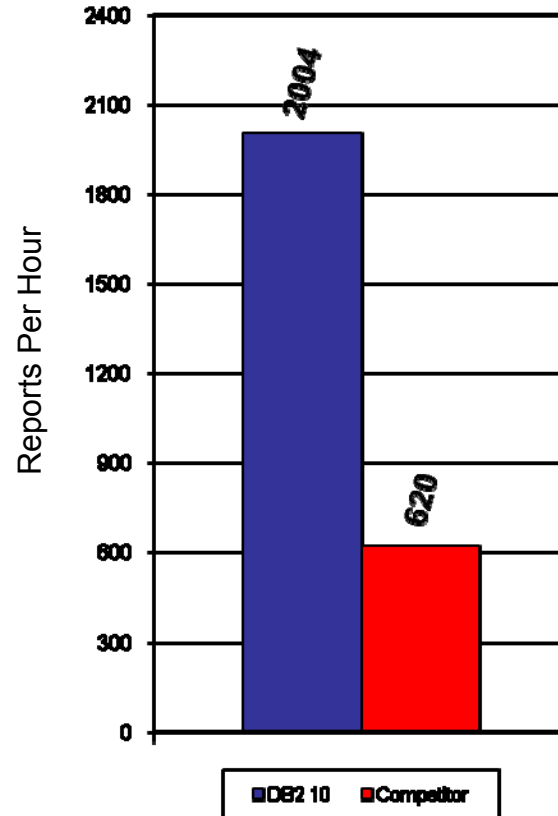

Reports Per Hour
at 750GB data size
(Higher is Better)

1.1X More
Large Reports

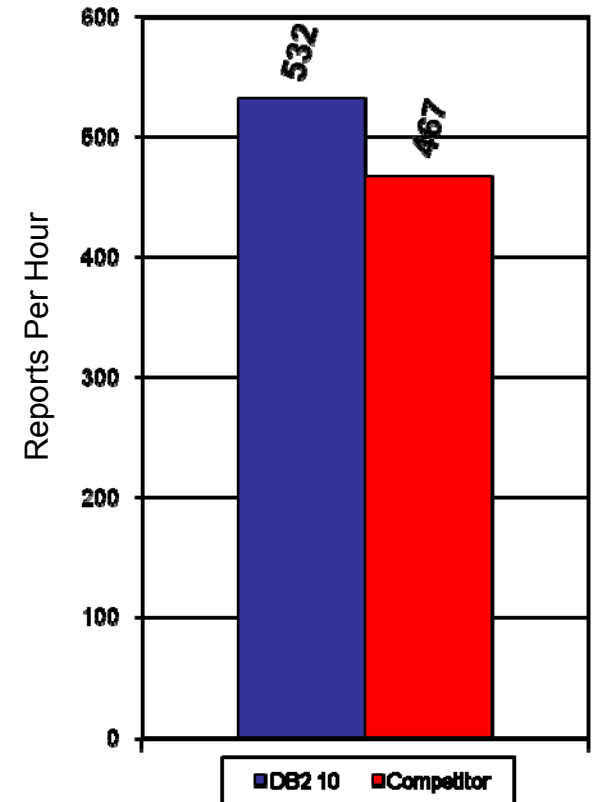

Reports Per Hour
at 750GB data size
(Higher is Better)

DB2 For z/OS Is Also Optimized For Data Warehouse Queries

- Data Warehouse Workloads typically include a mix of simple, intermediate and complex queries
- Data is partitioned to increase parallelism and compressed to increase I/O performance
- DB2 for z/OS Cost Based Optimizer decides best execution plan for each query
 - ▶ Simple queries typically assigned to a single processing thread
 - ▶ Complex queries may be decomposed into operations that execute in parallel
 - ▶ Queries may be automatically rewritten to take advantage of pre-computed partial results in materialized query tables (MQT)
- Result: Optimum Throughput

Platform Capabilities Benefit Both Operation BI And Deep Analytics

- More processors, memory and cache than other enterprise servers provides high concurrency
- I/O offloaded to the Dedicated I/O Sub-system
- Parallel Sysplex clustering designed for near linear scaling
- Hardware compression
- Optimized resource sharing for mixed queries with WLM
- DS8000 delivers high storage bandwidth with caching
- Unmatched scalability
- Systematic Disaster Recovery
- Attractive pricing with IBM Smart Analytics Solution 9700

Add IBM DB2 Analytics Accelerator For Even More Optimization

- A workload-optimized, blade-based appliance with storage integrated into the hardware rack and based on Netezza Technology
- Pre-load data from DB2 for z/OS into IDAA at over 400GB/hr and update by partitions
- Deeply integrated with DB2 for z/OS and transparent to applications
- Significantly speeds up the response time for a wide variety of complex queries using massively parallel processing architecture and patented data filtering technology at streaming speed using Field Programmable Gate Arrays (FPGAs)
- Drives down the costs of data warehousing and business analytics



Breakthrough Technology Enabling New Opportunities

IDAA Leverages Massively Parallel Processing To Speed Up Complex Queries

Data partitioned across CPUs and storage

Query distributed to CPU/FPGAs which decompress and filter data in real-time.

SMP Host assembles results and returns

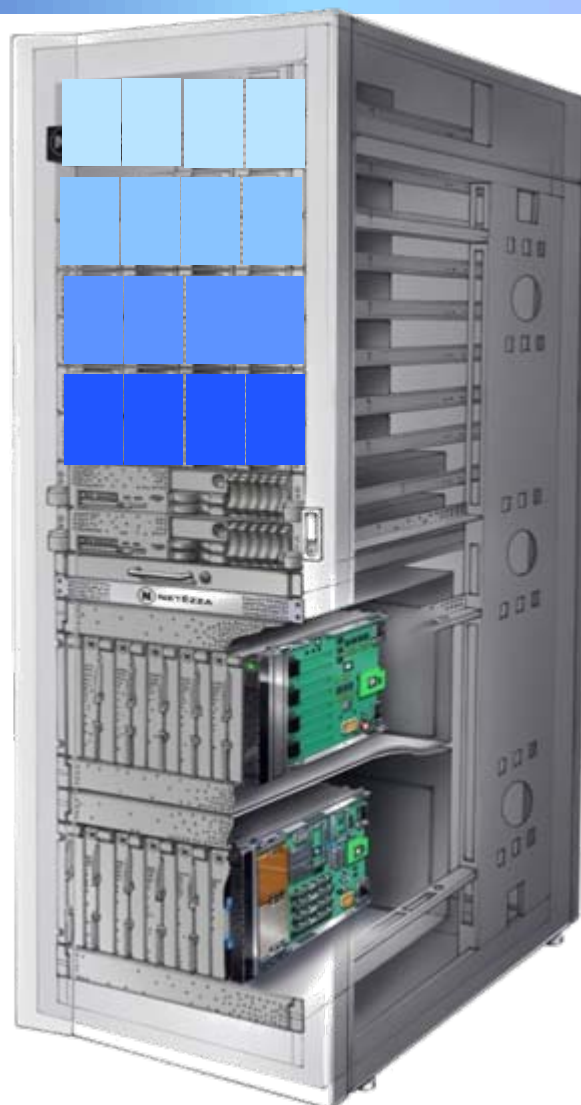

Storage

SMP Hosts

CPU/FPGA

“...when something took 24 hours I could only do so much with it, but when something takes 10 seconds, I may be able to completely rethink the business...” SVP, Nielsen

Outstanding Customer Results With IDAA

| Query | DB2 (Secs) | DB2 + IDAA (Secs) | Speed Up | Rows Reviewed | Rows Returned |
|---------|---------------|----------------------|---------------|------------------|------------------|
| Query 1 | 9,540 | 5 | 1,908x | 2,813,571 | 853,320 |
| Query 2 | 8,220 | 5 | 1,644x | 2,813,571 | 585,780 |
| Query 3 | 4,560 | 6 | 760x | 8,260,214 | 274 |
| Query 4 | 4,080 | 5 | 816x | 2,813,571 | 601,197 |
| Query 5 | 4,080 | 70 | 58x | 3,422,765 | 508 |
| Query 6 | 3,180 | 6 | 530x | 4,290,648 | 165 |
| Query 7 | 3,120 | 4 | 780x | 361,521 | 58,236 |
| Query 8 | 2,640 | 2 | 1,320x | 342,529 | 724 |
| Query 9 | 2,520 | 193 | 13x | 4,130,107 | 137 |

Speed Ups Ranging From 13x to 1,908x

Actual customer results, October 2011

Customers Are Excited About Business Analytics On zEnterprise



DB2 Analytics Accelerator: “we had this up and running in days with queries that ran over 1000 times faster”



DB2 Analytics Accelerator: “we expect ROI in less than 4 months”



Cognos BI for System z “We didn’t have to justify a higher cost for putting this on the mainframe, *it was cheaper!*”

Intelligent Solutions, Inc.

Analyst Claudia Imhoff “the industry pendulum in swinging towards centralization and there is no better platform than the mainframe”

Example: BI Day Fixed-Set Of Analytic Reports Run Concurrently On A Periodic Schedule

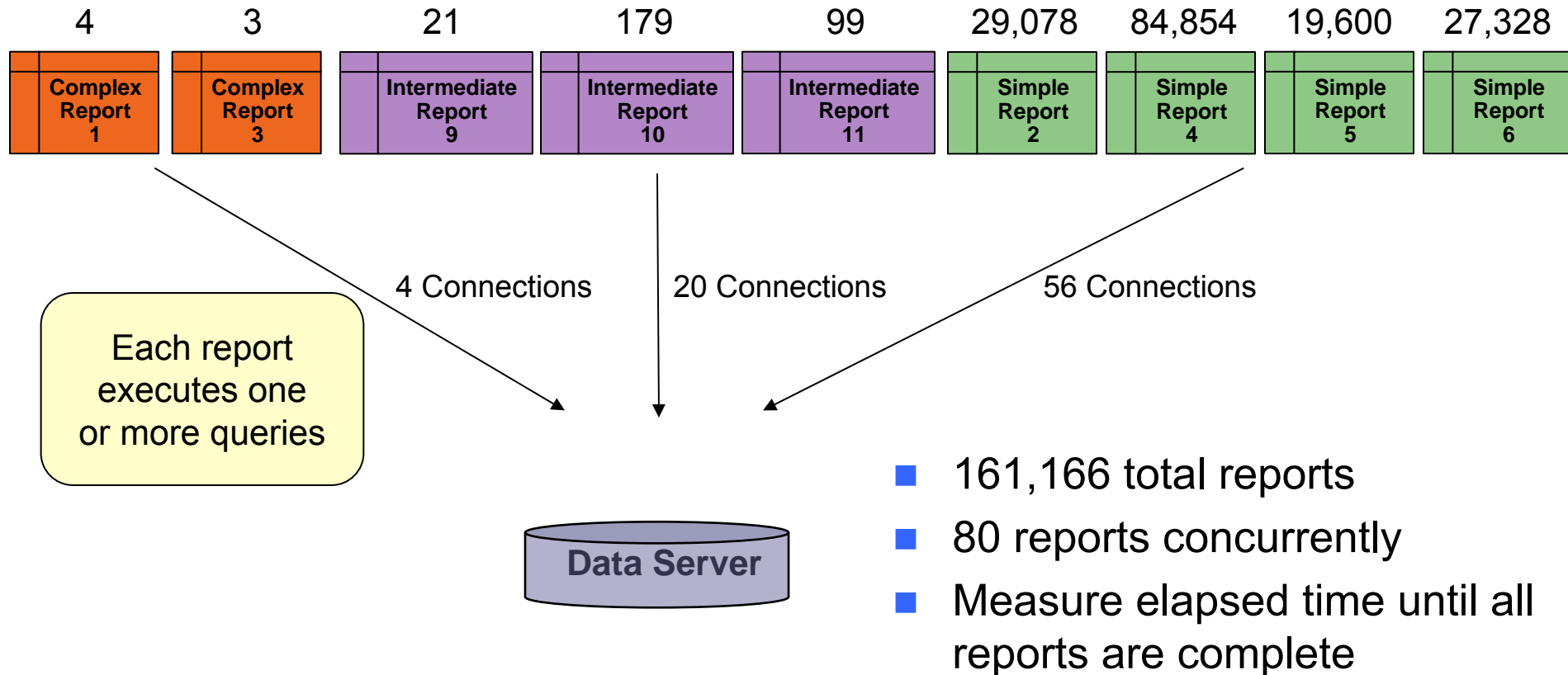

Note: Distribution of complex, intermediate, and simple workloads based on Forrester Research, Profiling the Analytic End User for Business Intelligence, 2004

BI Day Fixed-Set Analytic Reports Run Concurrently On A Periodic Schedule

- CASE 1:
Run concurrently 160,860 simple reports and 306 intermediate and complex reports on Competitor ¼ Rack
- CASE 2:
Run concurrently 160,860 simple reports and 306 intermediate and complex reports on IBM Smart Analytics System 9700 with dedicated 24-cores
- CASE 3:
Run concurrently 160,860 simple reports on IBM Smart Analytics System 9700 10-cores and in parallel offload 306 intermediate and complex reports serially to IDAA (Twinfin 12)

IBM DB2 Analytics Accelerator Makes A Great Analytics Solution Even Better

Time To Completion For Fixed Size Concurrent Workload – 1 TB

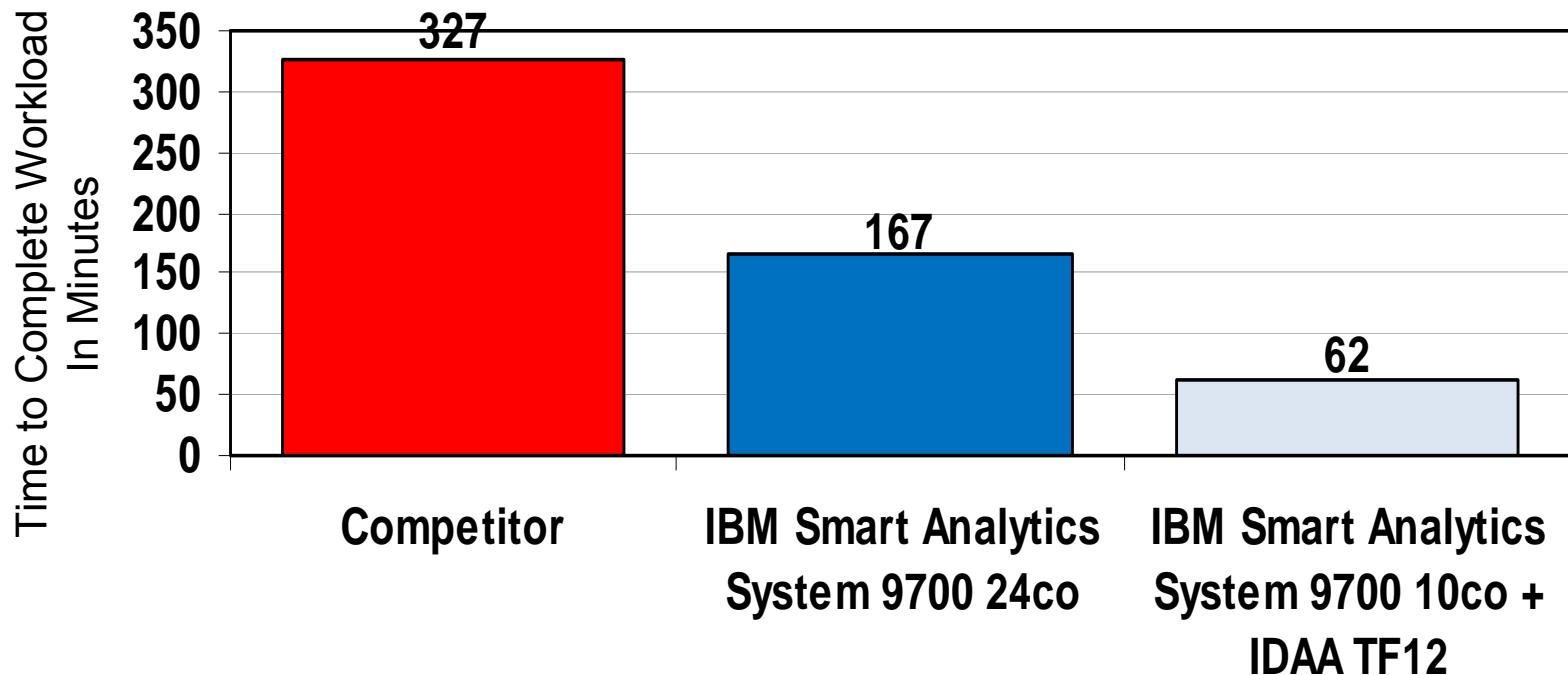

Lower is better

Test measures time to complete a fixed number of 161,166 concurrently executing reports

Based on BI Day Tests. Performance numbers may vary based on workload profiles. IBM Smart Analytics System + IDAA performance estimated from IBM Smart Analytics System running simple reports and NZ TF12 running intermediate + complex reports

Running Analytics On Optimized zEnterprise Platform Saves 75% Over Competition

Competitor

Quarter Rack



IBM Smart Analytics System 9700

DB2
(IBM Smart Analytics System 9700)
z/OS
12 GP+12 zIIP



IBM Smart Analytics System 9700 + IDAA

DB2
(IBM Smart Analytics System 9700)
z/OS
5 GP+5 zIIP



Netezza TwinFin 12



Unit Cost (3yr TCA) **\$97/RpH**

Unit Cost (3yr TCA) **\$62/RpH**

Unit Cost (3yr TCA) **\$24/RpH**

| | |
|-----------------------------------|-------------|
| RpH (Reports/Hour) | 29,572 |
| Competitor ¼ Rack (HW+SW+Storage) | \$2,857,500 |

| | |
|---|-------------|
| RpH (Reports/Hour) | 57,904 |
| IBM Smart Analytics System 9700 24-co (HW+SW+Storage) | \$3,600,000 |

| | |
|---|-------------|
| RpH (Reports/Hour) | 154,893 |
| IBM Smart Analytics System 9700 10-co (HW+SW+Storage) | \$1,500,000 |
| NZ TF12 (HW+SW+Storage) | \$2,140,600 |

Based on IBM internal tests of Smart Analytics 9700 + IDAA solution compared to results of testing of a competitor's configuration (previous version; no longer available) executing an analytics workload in a controlled laboratory environment and a 3 year total cost of acquisition (based on US list prices). The cost calculation compares the average cost per report for 161,166 concurrently executing mixed complex, intermediate and simple report types. Intermediate/Complex reports offloaded to IDAA for serial execution. 9700+IDAA results are a projection based on actual data for simple reports on SA 9700 and complex/intermediate report times run on separate Netezza TwinFin 12. 3 year total cost of acquisition includes expected hardware, software, service & support. Results may not be typical and will vary based on actual configuration, applications, specific queries and other variables in a production environment. Users of this document should verify the applicable data for their specific environment. Contact IBM and see what we can do for you.

5X performance
4X price performance

IBM Smart Analytics System 9700 – A Comprehensive Package For Business Analytics

- Pre-configured appliance-like solution with aggressive solution edition pricing
- Hardware/OS
 - ▶ IBM zEnterprise z196 technology
 - ▶ IBM System Storage DS8800 Intelligent Disk controller
 - Large controller cache and 3 Tier disk offering
 - ▶ z/OS 1.12
- Unique Software
 - ▶ DB2 10 for z/OS
 - ▶ Cognos 10 BI (Linux on System z)
 - ▶ InfoSphere Warehouse (Linux on System z)
 - ▶ SPSS Modeler (Linux on System z)
- Optional Components
 - ▶ IBM DB2 Analytics Accelerator
 - ▶ Solid State drives, integrated within DS8800
 - Easy Tier to identify and migrate “hot data” to SSD

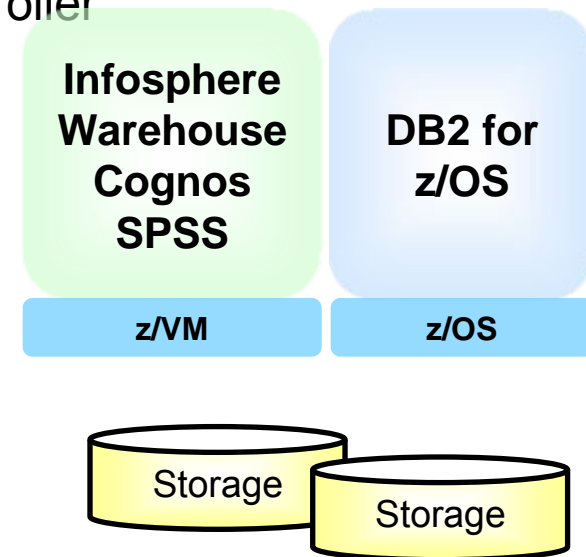

zEnterprise Now Provides All Of The Components You Need For A Complete Analytic Solution In One Platform

Operational Business Intelligence
Simple Queries
How are we doing?

Cognos
SPSS

Linux
z/VM

Deep Analytics
Longer Queries
Why?

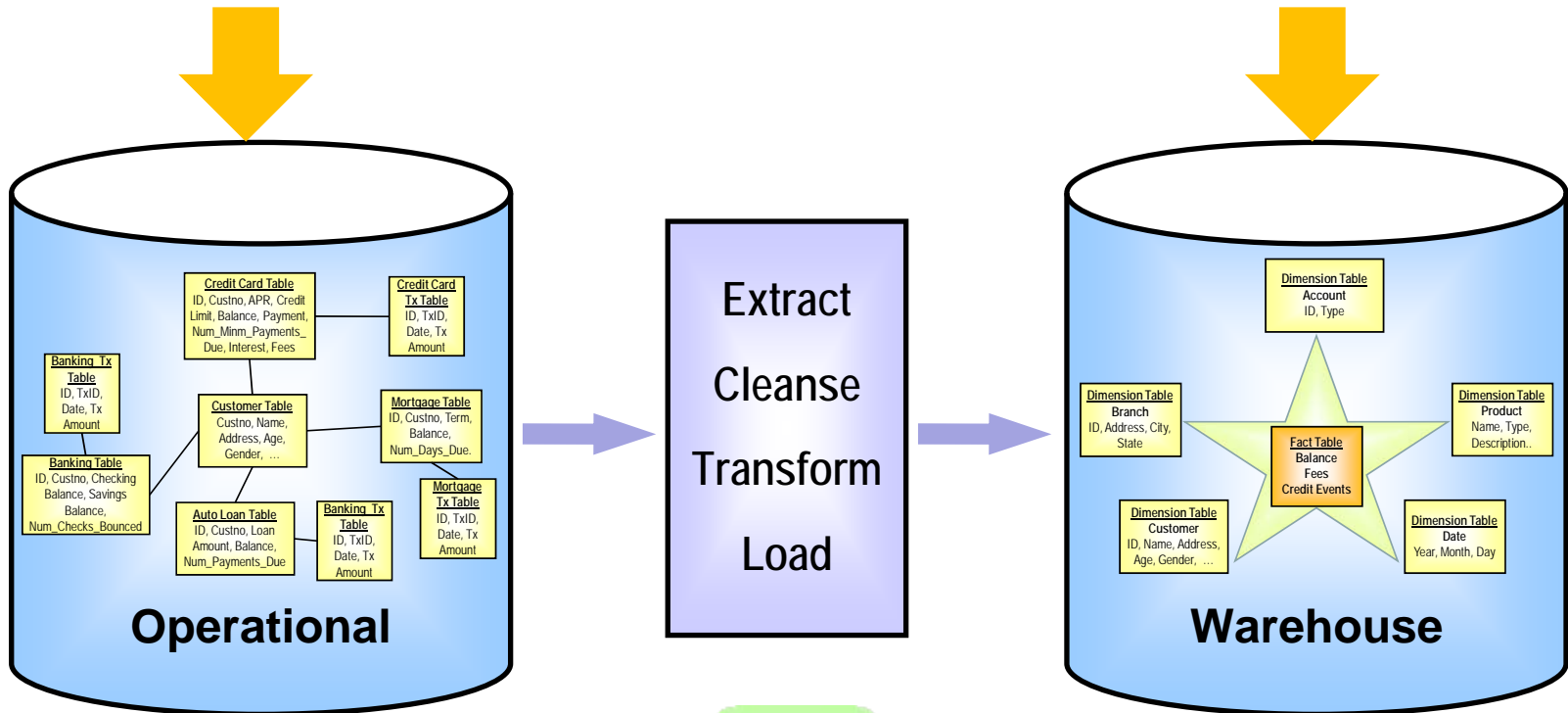

DB2

z/OS

Infosphere
Information
Server

Linux
z/VM

Infosphere
Warehouse

DB2

Linux
z/VM

z/OS

Cognos Can Generate Reports And Dashboards For Operational BI And Deep Analytics Queries

■ People-centric

- ▶ Server based business analytics accessed via browser
- ▶ Consistent user interface for different analytic activities
- ▶ Reuse new intelligence assets
- ▶ Built-in collaboration and social networking
- ▶ Threaded discussions, activities, and notifications

■ Easy to deploy and manage

- ▶ Implemented in Java, runs on WebSphere
- ▶ Scales up and out across heterogeneous hardware and operating systems
- ▶ Runs on Linux on System z

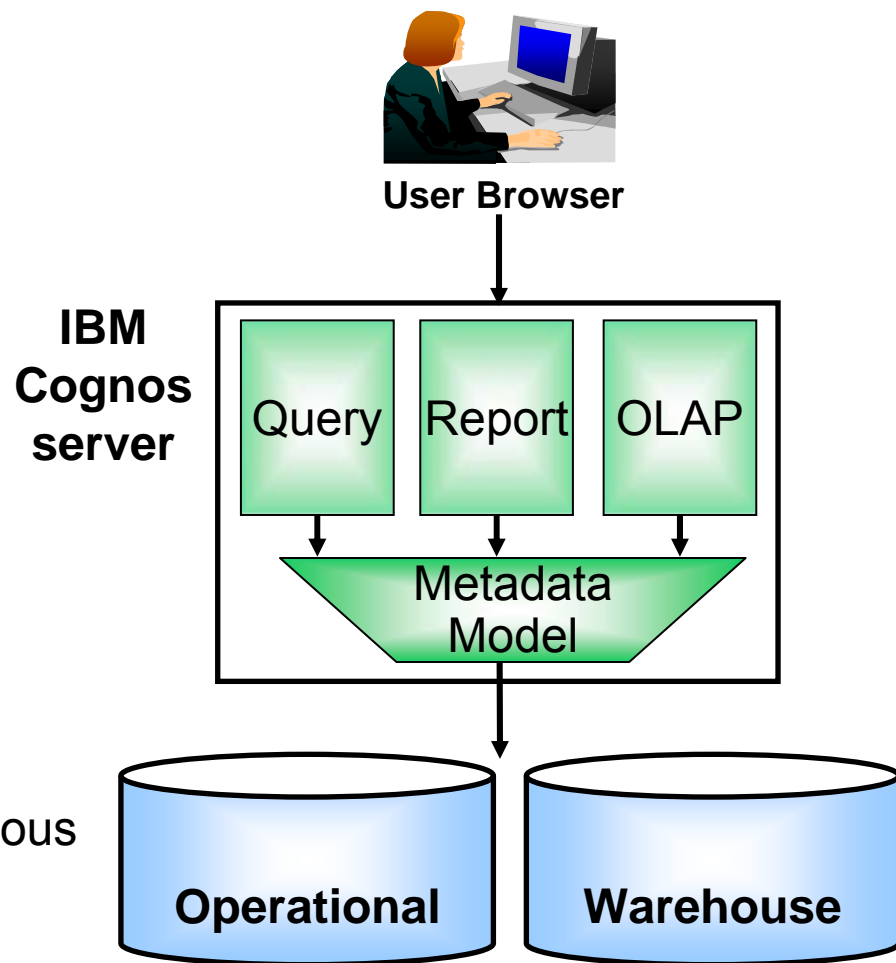

Reuse Prior Cognos Reports In New Deliverables

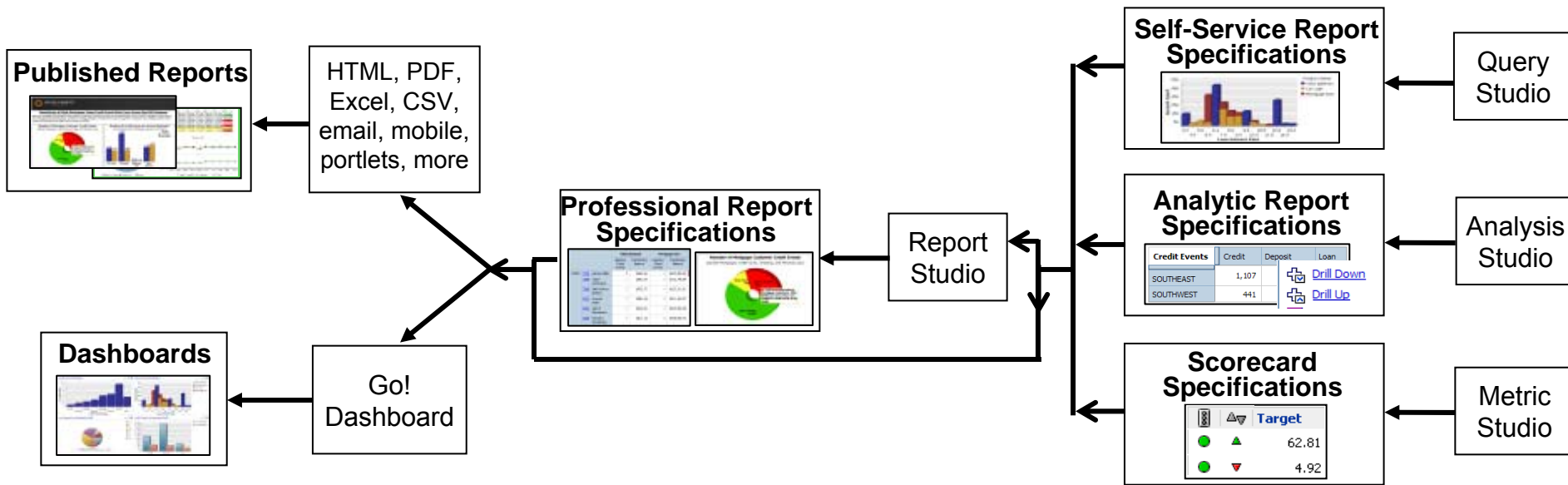

- Author once, consume anywhere
- All analytic assets share a common metadata model and a common multilingual report specification
- Ensures consistent information and enables reuse across platform functions

DEMO: Use Cognos To Identify New Business Insights from the Data Warehouse

1. Reviewing Mortgage data provides false impression of credit risk
2. Report looking at negative credit events (bounced checks, missed payments) of customer across all accounts (Credit Card, Checking, etc...), identifies high-risk mortgages
3. Assess risk of flagged customer using FileNet case management data (Appraisal) linked to the Report



Identifying At-Risk Mortgages Using Credit Event Data from Across the SOF Business

Many SOF mortgage account holders also hold SOF credit cards, checking accounts, and personal loans. This is a report of negative credit events in non-mortgage accounts belonging to current SOF mortgage holders. A credit event is any non-payment of a balance due. Checking account credit events are Insufficient Fund (ISF) events ("bounced checks").

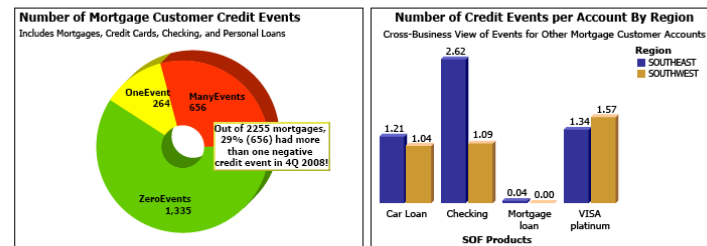

4Q 2008 Mortgage Customer Detail by Region and State

Colors: Credit events numbers are color coded. Accounts with greater than 8 events are shown in **block red**.
Links: Customer ID link opens customer's mortgage document folder using FileNet Workplace XT. Authentication required.

Region: SOUTHEAST

State: FL

| | | | Checking | | VISA platinum | | Car Loan | | Mortgage loan | | Summary | |
|-------|------|--------------------|------------------------|-----------------|------------------------|-----------------|------------------------|-----------------|------------------------|-----------------|------------------------|-----------------|
| | | | Negative Credit Events | Current Balance | Negative Credit Events | Current Balance | Negative Credit Events | Current Balance | Negative Credit Events | Current Balance | Negative Credit Events | Current Balance |
| TAMPA | 7228 | Herman Miller | 11 | \$1,433.86 | 3 | \$865.46 | 3 | \$24,465.55 | 0 | \$232,285.82 | 17 | \$259,050.71 |
| | | 7928 | 11 | \$1,433.86 | 3 | \$865.46 | 3 | \$24,465.55 | 0 | \$232,285.82 | 17 | \$259,050.71 |
| | 7248 | Julia P Lamoreaux | 4 | \$1,251.57 | 2 | \$891.85 | 2 | \$52,120.40 | 0 | \$722,748.89 | 8 | \$777,012.71 |
| | | 7948 | 4 | \$1,251.57 | 2 | \$891.85 | 2 | \$52,120.40 | 0 | \$722,748.89 | 8 | \$777,012.71 |
| | 8044 | Kelly O Montecalvo | 4 | \$1,127.24 | 2 | \$844.82 | 2 | \$74,670.00 | 0 | \$323,366.59 | 8 | \$400,008.65 |
| | | 8044 | 4 | \$1,127.24 | 2 | \$844.82 | 2 | \$74,670.00 | 0 | \$323,366.59 | 8 | \$400,008.65 |
| | 8028 | Shad I Davis | 4 | \$780.11 | 2 | \$830.11 | 2 | \$43,230.00 | 0 | \$919,073.43 | 8 | \$963,913.65 |

At risk customers are identified

Miami Dade County Runs Cognos On Linux On System z

Requirements:

- Demand for BI has really taken off
 - ▶ New Federal reporting requirements
 - ▶ Every new system, every new solution, every new application is having a business intelligence component
- Multiple Cognos 8 BI deployments
- Wanted an enterprise BI standardized solution, but
 - ▶ Needed higher capacity – grow from approx 400 to 1000 users
 - ▶ Do more with less - less researchers, less software, less hardware, same staff
 - ▶ Had available IFL's on System z

Results:

- 11 days to move from distributed to System z deployment model for Cognos 8 BI
 - ▶ Quickly and easily meet new requirements
- Consolidate multiple BI deployments on to a single platform
- Single point for BI administration
- Consolidate multiple disparate data sources
- Ensure 99.999% availability
- Offer a complete disaster recovery plan
- Additional green savings



SPSS Enables Customers To Predict Future Events And Drive Better Business Outcomes

Capture

Data Collection delivers an accurate view of customer attitudes and opinions

IBMSPSS Data Collection



Predict

Predictive capabilities bring repeatability to ongoing decision making, and drive confidence in your results and decisions

IBM SPSS Statistics*/Modeler*/Text Analytics



Platform

Pre-built Content



Act

Unique deployment technologies and methodologies maximize the impact of analytics in your operation

IBM SPSS Decision Management Collaboration & Deployment *

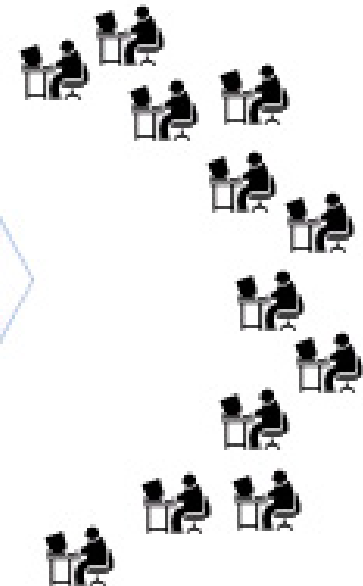

* Runs on Linux on System z

What Can We Learn From Historical Data That Would Help Evaluate New Customers

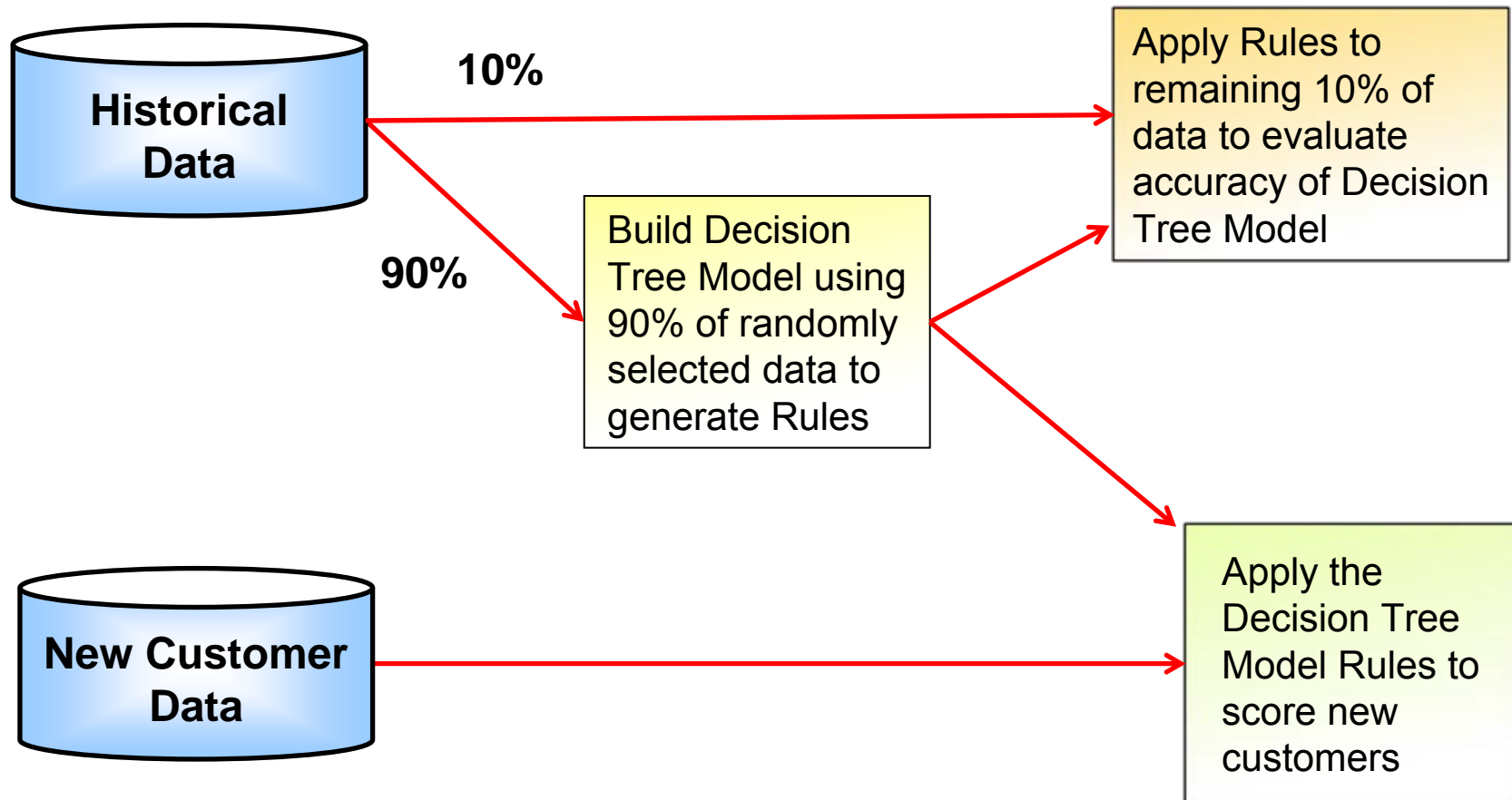

Example: Create A Model For Identifying Risky Customers For Loan Approval

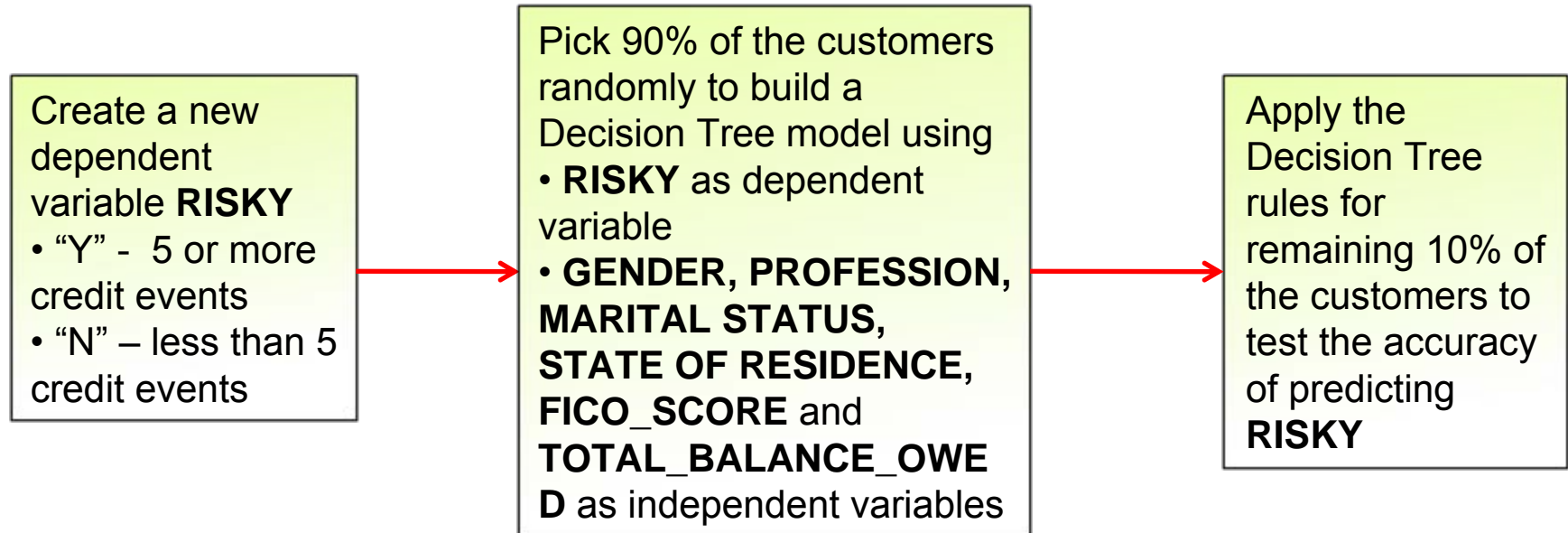

DEMO: Discover Rules For Identifying Risky Customers Using SPSS Statistics

1. Load data from Data Warehouse on DB2 for z/OS into SPSS Statistics
2. Pre-process the data to create new attributes for quantifying negative credit events across different product lines and create a risk flag for mortgage
3. Run Decision Tree to discover rules for characterizing risky customers
4. Evaluate if Herman Miller is classified as “RISKY” by applying the Decision Tree rules

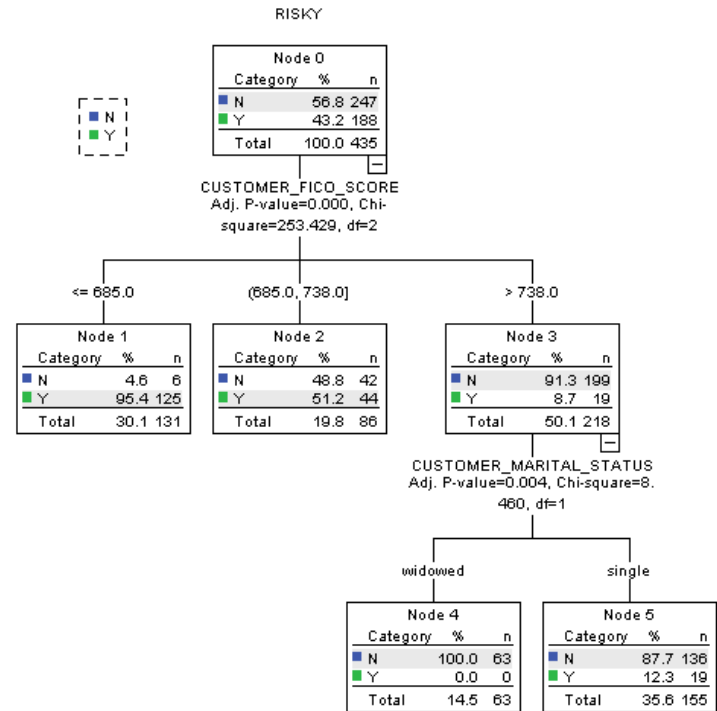

- Credit Limits identified for characterizing risky customers
- Use these credit limits for automated loan approval process

Run End-To-End BI On zEnterprise To Reduce Costs And Improve Reliability

- 60-70% of operational data resides on System z*
- zEnterprise offers a fully integrated, optimized solution from operational data to business analytics in one platform
- Consolidating data warehouses and data marts on IBM Smart Analytics 9700 with IDAA can reduce costs by 75%



* Source <http://www.ibmsystemsmag.com/mainframe/trends/whatsnew/The-Mainframe-at-a-Crossroads/>