

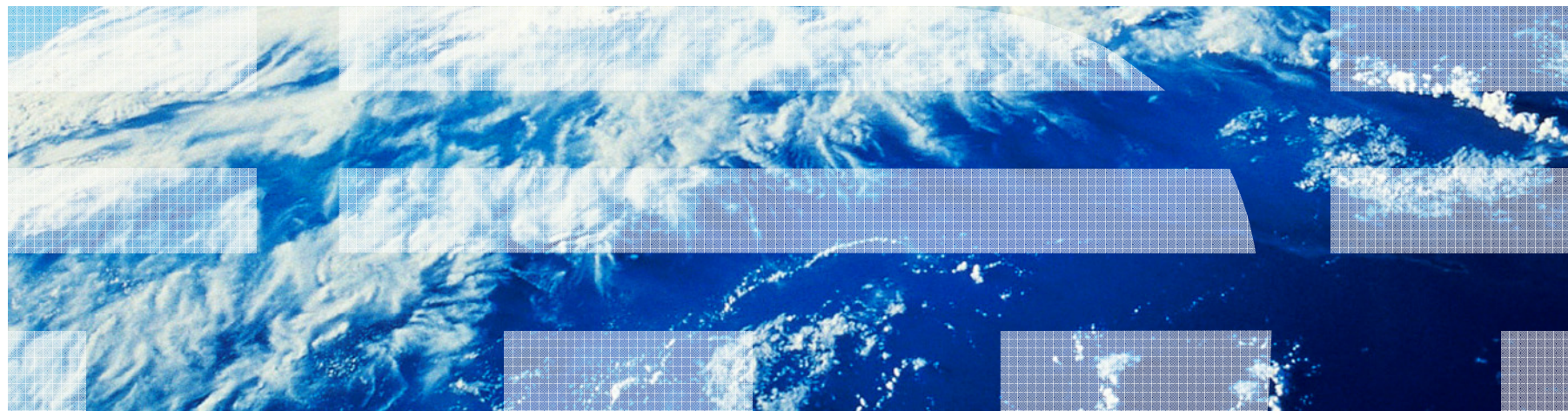

DS8700 & DS8800

World Class Enterprise Storage

Craig McKenna
Technical Sales Leader, System Storage
Growth Markets Unit



Agenda



- **Storage Overview**
- **Introducing new DS8800 model**
- **Enterprise Progression**
- **Dramatic efficiency**
- **Additional enhancements**
- **Conclusion**

IBM Storage is about the smart movement and management of information
IBM Storage *Grows Capacity without Complexity*

IBM Smarter Planet Vision



The world is flatter and smaller. Now it's becoming smarter.



The world is generating 15 petabytes of data daily.

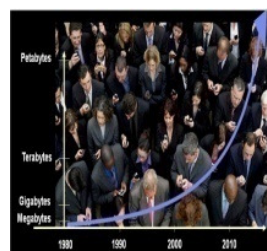

Information is doubling every 18 months. Storage capacity is growing 45% yr.



80% of new data growth is unstructured content.

How do I create an infrastructure that drives down cost, protects information, and delivers new intelligence to enable smarter business decisions?

Data Deluge

2



Did You Know?

Estimated Enterprise Data Growth in 5 Years?

650%

80% Will be Unstructured!

Gartner.

With the Information Explosion Comes a Value Gap

Storage Requirement Growth Outpaces Storage Budget Growth

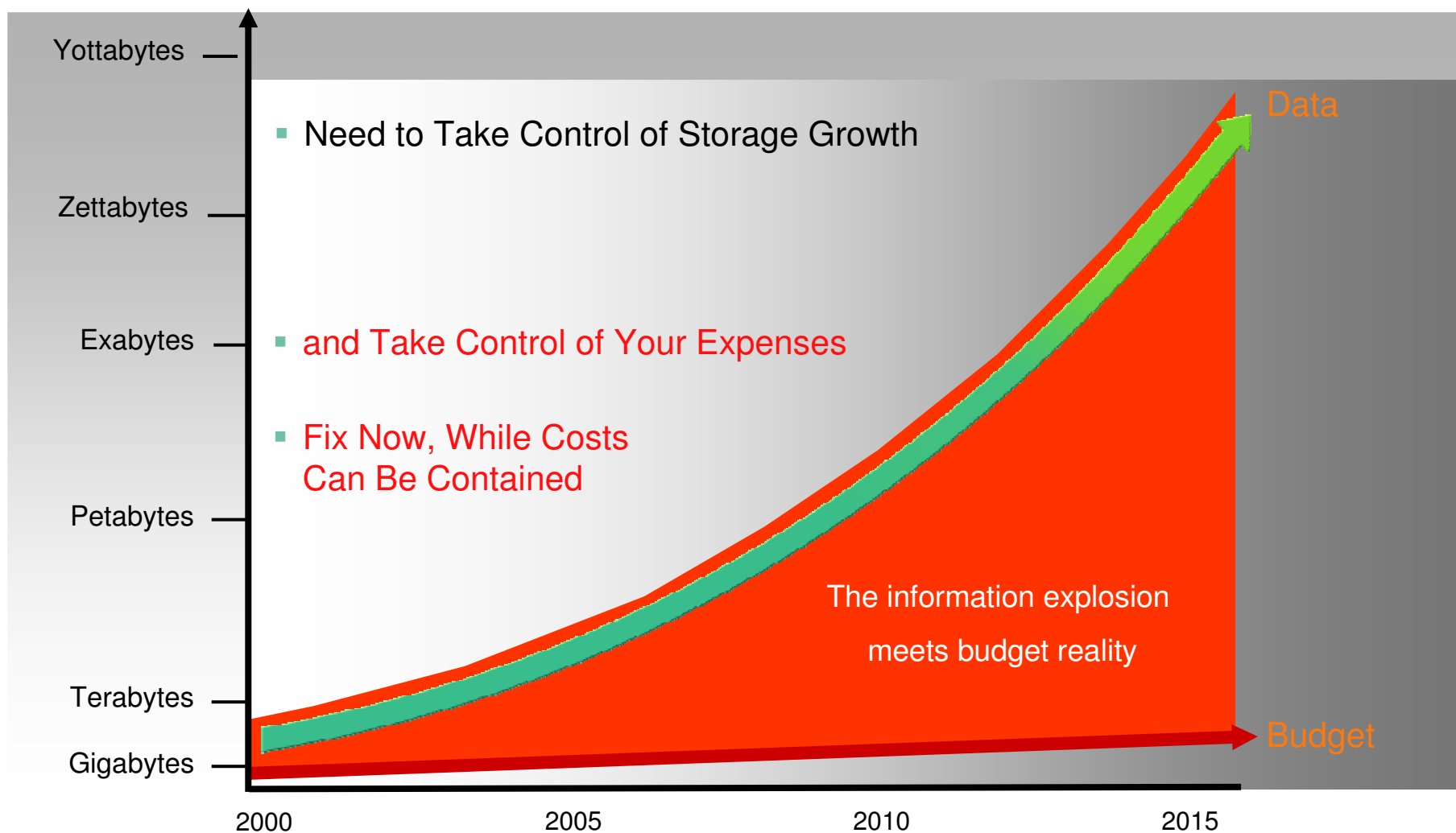

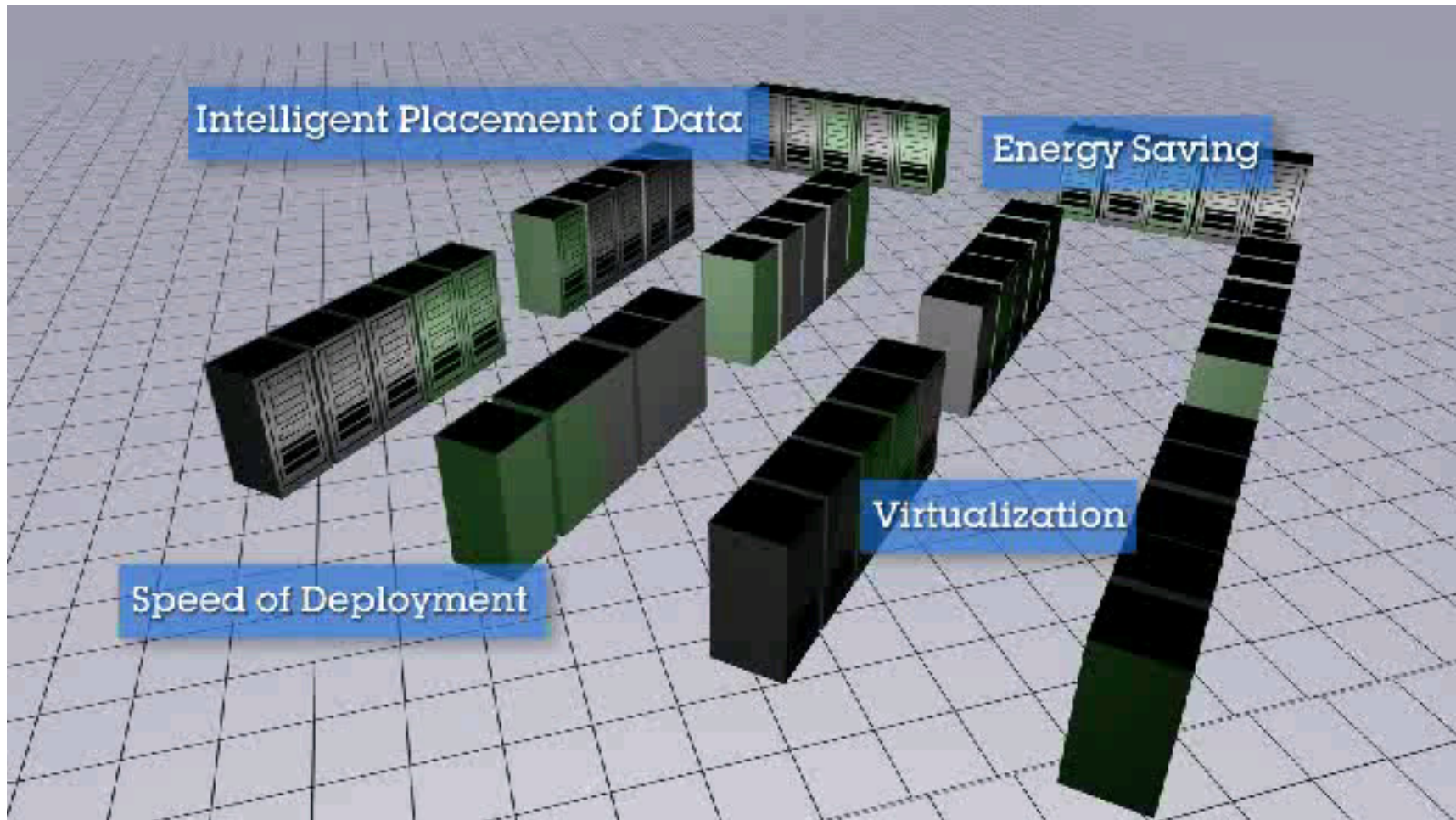

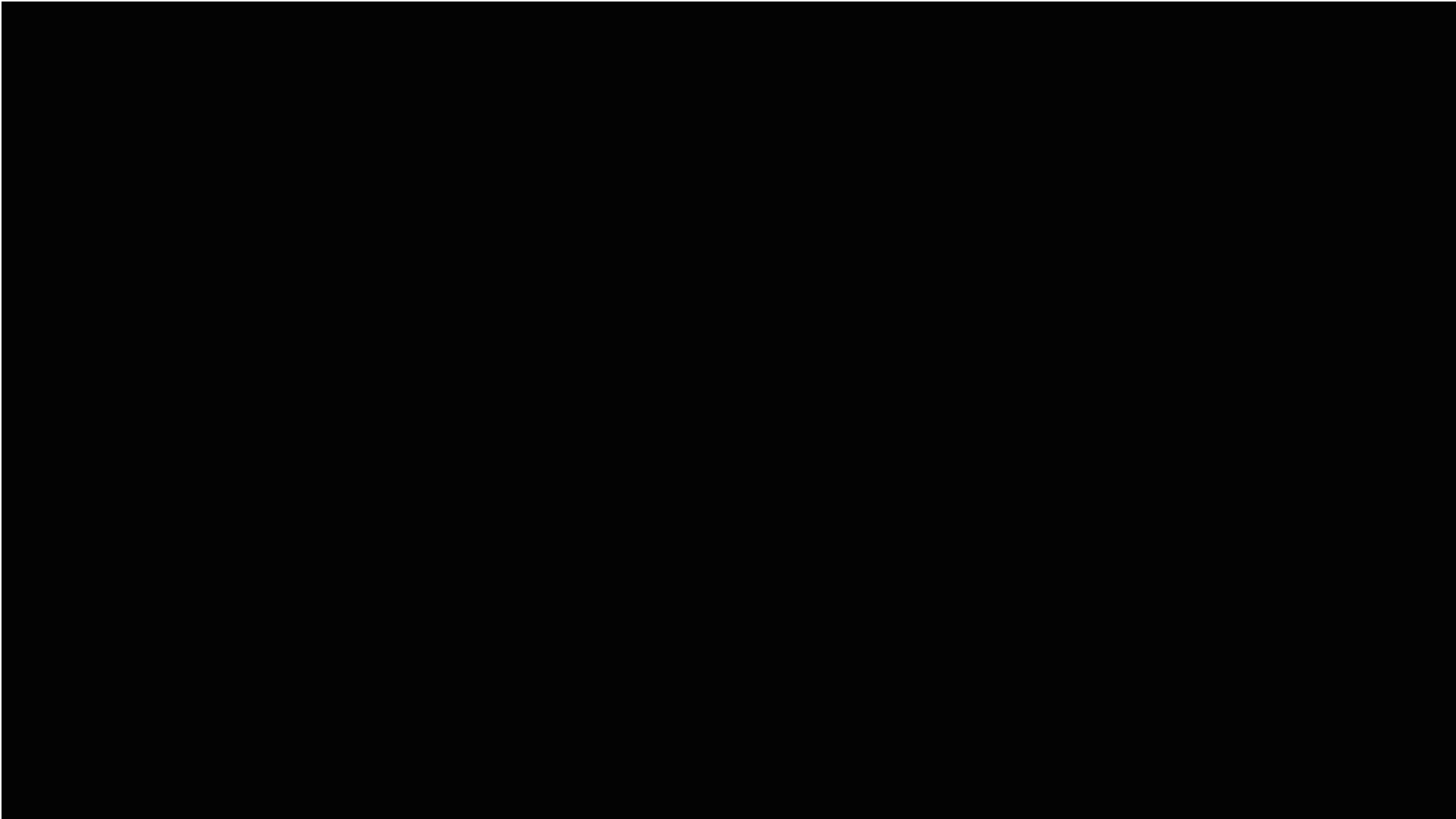

Introducing the DS8800

4th-generation DS8000 enterprise disk platform

- **Exceptional reliability for critical workloads**
- **Faster hardware throughout**
- **Higher capacity with more efficient footprint**

Announcing on October 7...

Generally Available on November 19



DS8800

From DS8300 to DS8700 – Remove Performance Bottlenecks



Remove Power 5 and Rio-G

Change in I/O structure

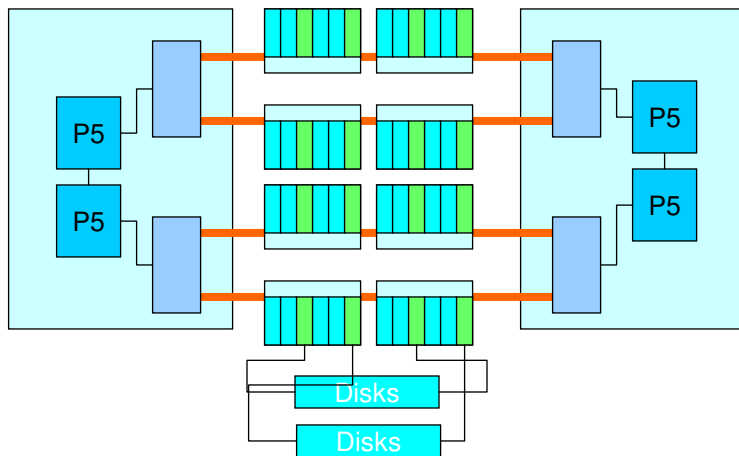

P5 to P6 server upgrade.

New PCIe I/O Drawer attachment

- Point-to-point server to I/O bay connection via PCI-e cables.
- The server to server communication path continues to use RIO.
- Isolated from I/O traffic.

DS8700 PCIe cable I/O attach

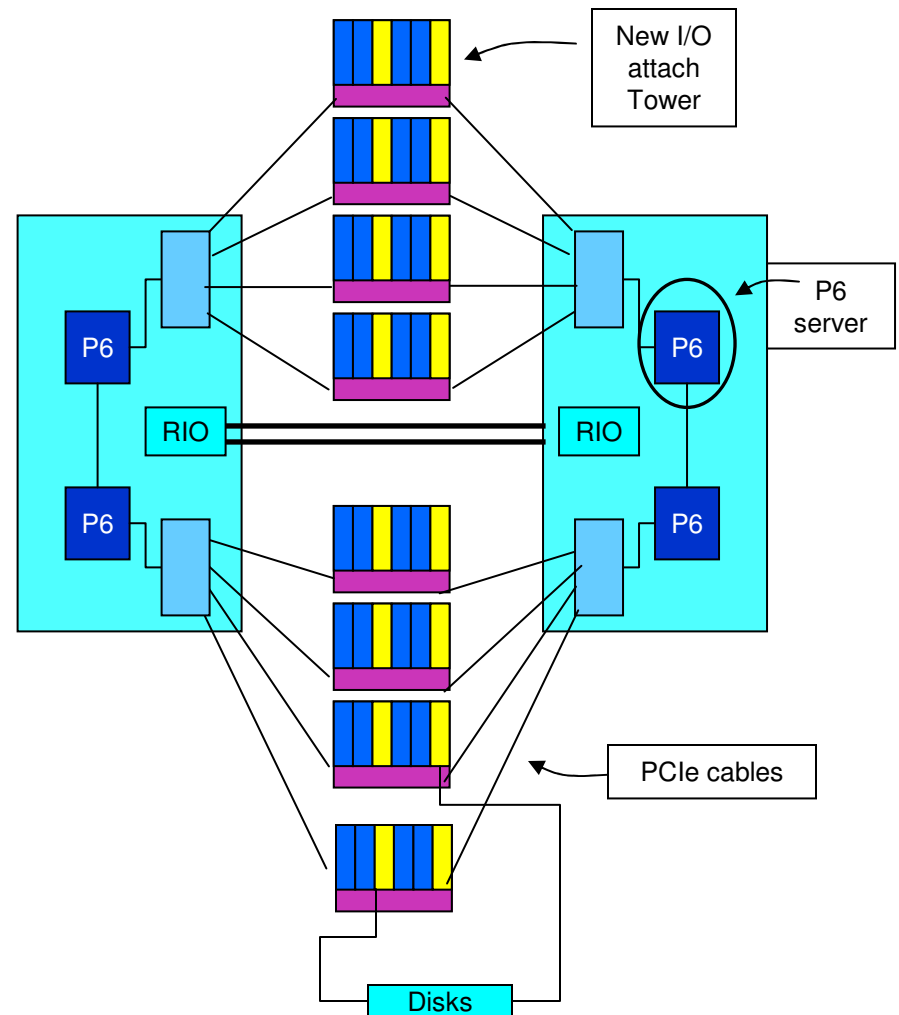

From DS8700 to DS8800 – Bandwidth – Density – Power



- Upgraded P6 Servers
 - Upgrade to 2 or 4-way P6+ 5Ghz
- New host adapter
 - 8 ports, 8Gb SAN connection, multi-core, PCI-e
- New RAID adapter
 - 8 ports, 8Gb fibre channel, multi-core, PCI-e
- New disk enclosure & power system
 - Higher density, SFF SAS 2.0, 8Gb FC Fabric
 - Hot aisle / cold aisle cooling design

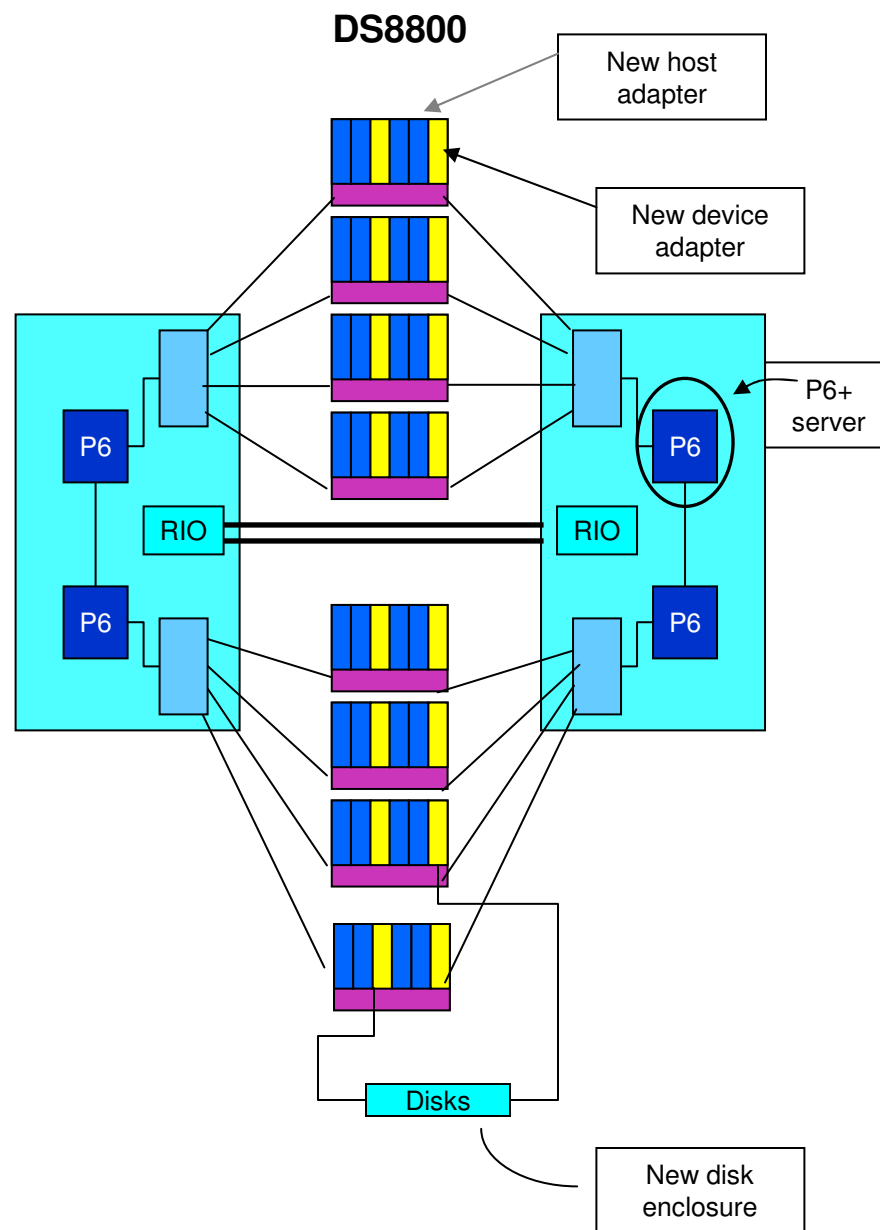

Performance comparison across DS8000 models

Open Results Summary

DS8800 Full Box Results– 96x RAID5 Arrays 768x 15K RPM HDDs, 16x SSDs, 8x DA Pair, 16x HA w/ 32x 8Gb ports					
		DS8300	DS8700	DS8800	% increase (vs. DS8300)
Database Open	4KB K IOps	165	191	196	3% (19%)
4K Read Hits	4KB K IOps	425	523	530	1% (25%)
4K Write Hits	4KB K IOps	164	203	222	1% (35%)
4K Read Miss	4KB K IOps	111	137	160	17% (44%)
Seq Read	GBps	3.9	9.7	11.8	22% (203%)
Seq Write	GBps	2.2	4.7	6.7	43% (205%)

DS8800 Component Results – 4port HA; RAID5 arrays					
			DS8700	DS8800	% increase
HA 4KB Read	4KB K IOps		78	190	144%
HA 4KB Write	4KB K IOps		42	110	162%
HA 64KB Read	GBps		530	2530	377%
HA 64KB Write	GBps		400	1420	255%
DA Pair 4KB Read	4KB K IOps		53	77	45%
DA Pair 4KB Write	4KB K IOps		19	32	68%
DA Pair 64KB Read	GBps		1.2	3.2	167%
DA Pair 64KB Write	GBps		0.77	1.42	84%

Performance comparison across DS8000 models

CKD Results Summary

DS8800 Full Box Results– RAID5					
384x 15K RPM HDDs, 48x 10K RPM HDDs, 8x DA Pair, 16x HA w/ 32x 8Gb ports					
		DS8300	DS8700	DS8800	% increase (vs. DS8300)
zHPF DB zOS	4KB K IOps	165	201	204	2% (24%)
FICON DB zOS	4KB K IOps	124	174	181	4% (46%)
zHPF 4K Read Hits	4KB K IOps	344	423	440	4% (28%)
zHPF 4K Write Hits	4KB K IOps	124	159	175	10% (41%)
FICON Seq Read	GBps	4.1	9.4	10.0	6% (144%)
FICON Seq Write	GBps	2.1	5.6	5.7	2% (171%)

4th-generation DS8000 enterprise disk system

The IBM POWER processor has been behind the success of IBM enterprise storage beginning with the Enterprise Storage Server in 1999

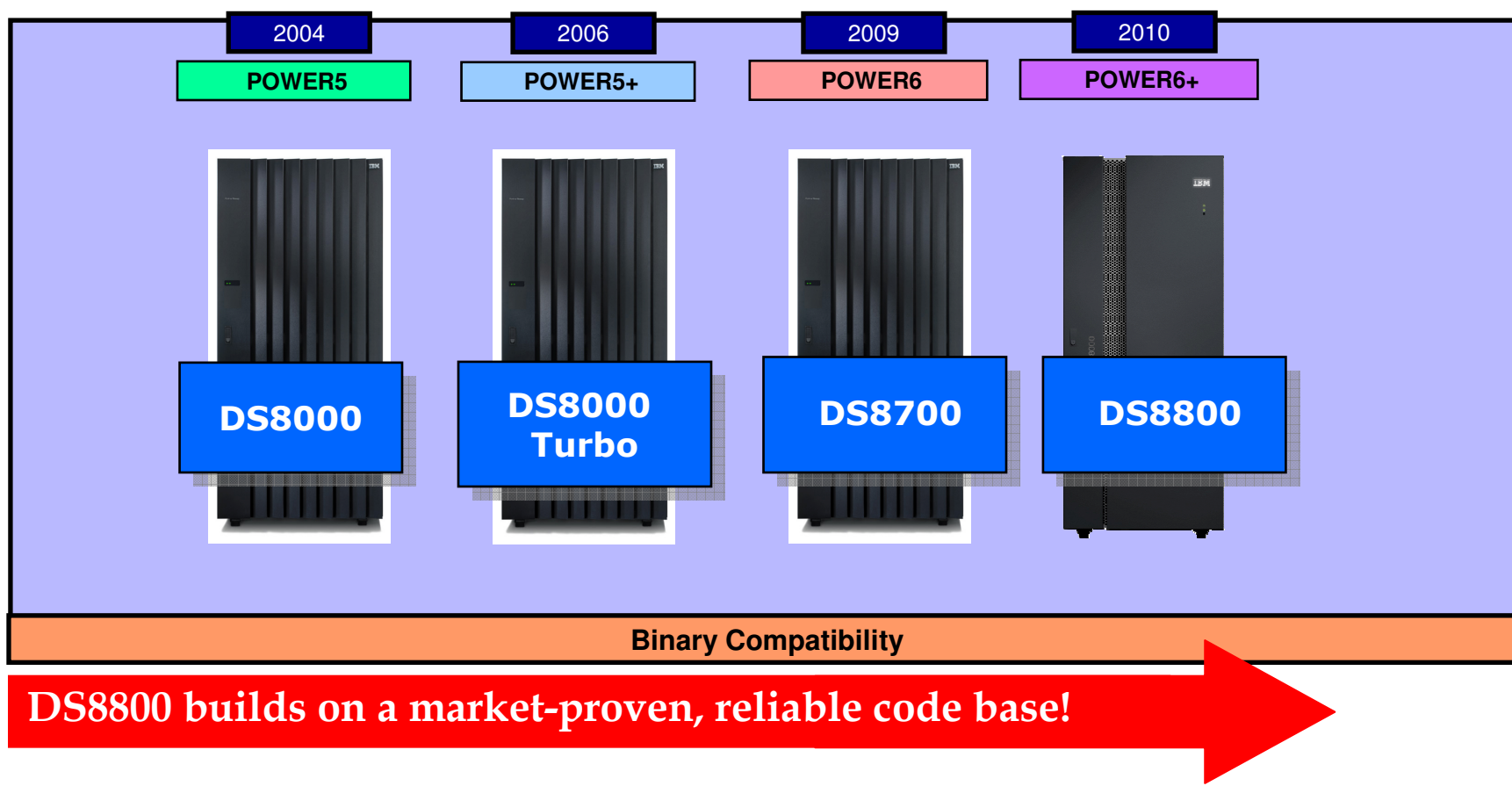

DS8000 family models

Two base models with scalable controllers and capacity



DS8700

- POWER6 controllers (2-way and 4-way)
- 4 Gb/s and 2 Gb/s host and device adapters
- 3.5" Enterprise Fibre Channel drives

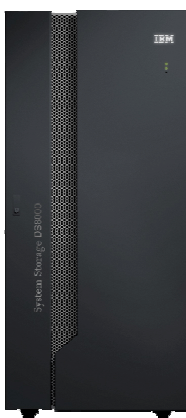

DS8800

- POWER6+ controllers (2-way and 4-way)
- 8 Gb/s host and device adapters
- 2.5" Enterprise SAS-2 drives

New level of performance and efficiency... same outstanding reliability



- New model
- New hardware
- Same microcode architecture

- Outstanding reliability
 - Faster performance
 - Greater efficiency and scalability

DS8800 hardware upgrades

Higher performance and efficiency

- Compact and highly efficiency drive enclosures
 - New 2.5", small-form-factor drives
 - 6 Gb/s SAS (SAS-2)
 - New enclosures support 50% more drives
- Upgraded processor complexes
 - IBM POWER6+ for faster performance
- Upgraded I/O adapters
 - 8 Gb/s host adapters
 - 8 Gb/s device adapters
- More efficient airflow
 - Front-to-back cooling
 - Aligns with data center best practices

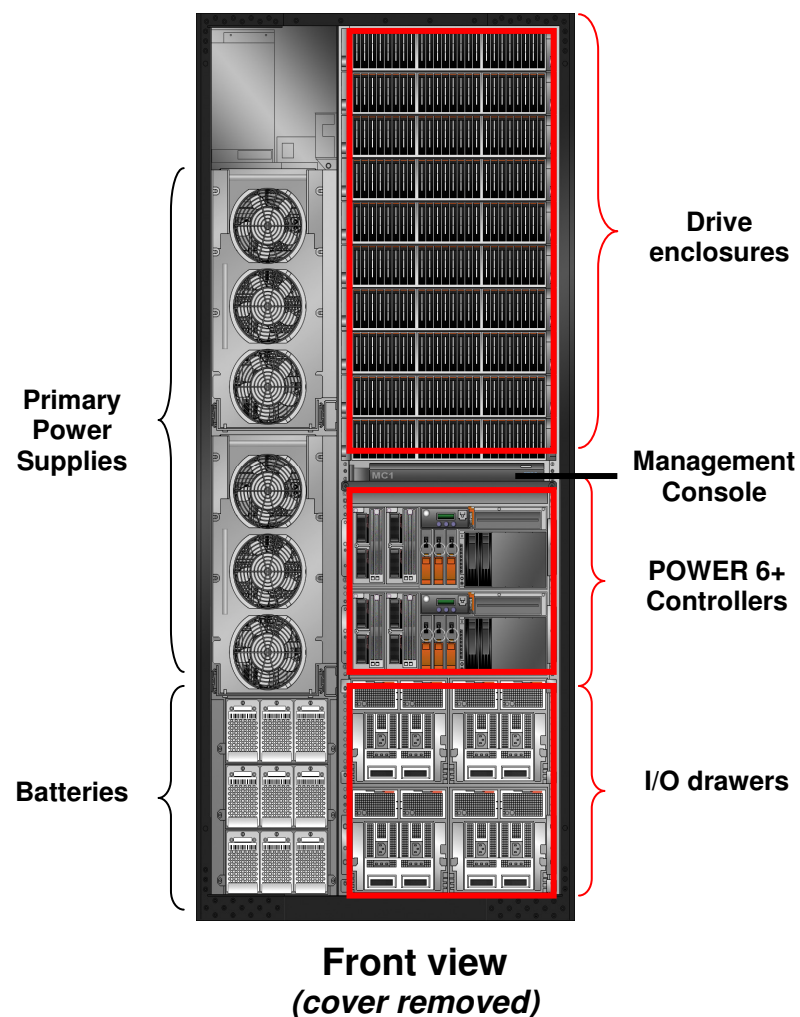

Dramatic efficiency and performance benefits

Disk enclosure comparison

New high-density enclosures



DS8700 Megapack



- Disk Technology
 - 3.5" (LFF) Fibre Channel
- Throughput
 - 2Gbps FC interconnect backbone
 - 2Gbps FC to disks
- Density
 - Supports 16 disks per enclosure
 - 3.5U of vertical rack space
- Cabling
 - Passive copper interconnect
- Modularity
 - Rack level power
 - Rack level cooling

DS8800 Gigapack



- Disk Technology
 - 2.5" (SFF) SAS
- Throughput
 - 8Gbps FC interconnect backbone
 - 6Gbps SAS to disks
- Density
 - Supports 24 disks per enclosure
 - 2U of vertical rack space
- Cabling
 - Optical short wave multimode interconnect
- Modularity
 - Integrated power
 - Integrated cooling

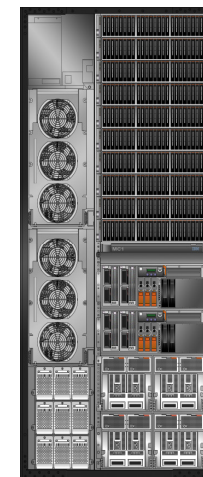

Storage efficiency with space-saving design

Saving money with high-density drives, enclosures, frames

- Client feedback is very positive on space-saving design
 - Small-form-factor drives
 - High-density drive enclosures
 - Almost double the drives in same frame footprint
- Benefits
 - More effective consolidation can lower operating costs
 - Support more workloads with smaller footprint
 - Reduce number of systems to manage
 - Reduce power and cooling costs

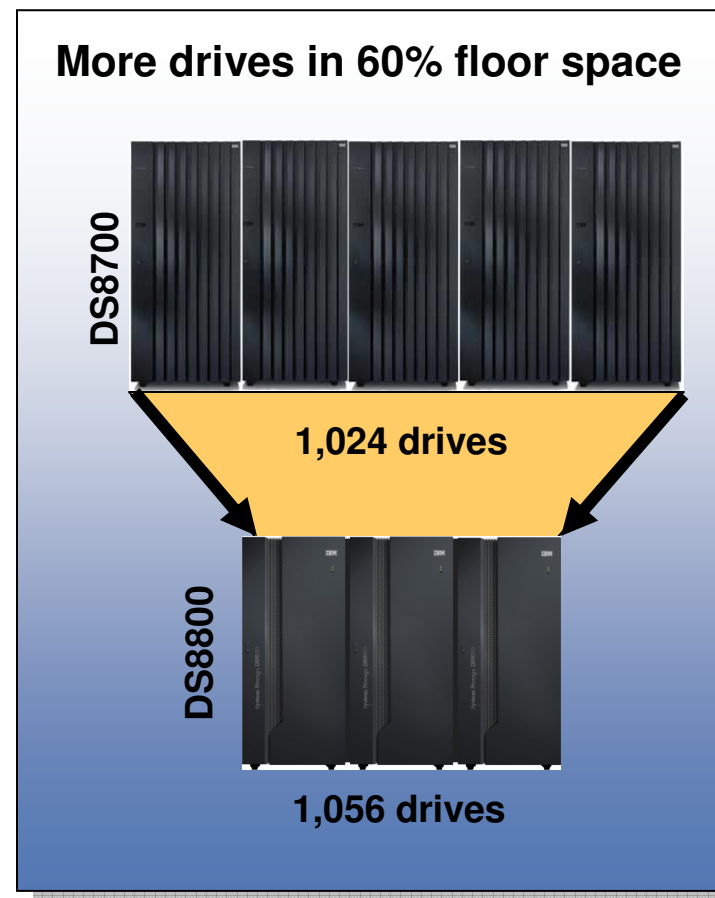
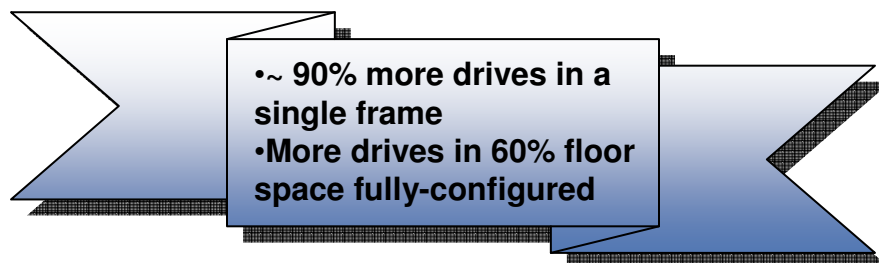

Extremely positive client feedback about substantial footprint reduction

Energy consumption comparison with DS8700 and DS8300



DS8800 with 1056 drives

- Base frame: 6.8kW
- Exp frame: 5.4kW
- Exp frame: 6.5kW

TOTAL: 18.7kW



DS8700 with 1024 drives

- Base frame: 6.8kW
- Exp frame: 7.1kW
- Exp frame: 6.1kW
- Exp frame: 6.1kW
- Exp frame: 3.0kW

TOTAL: 29.1kW

3-year cost savings

- 36% less energy usage; 40% less floor space
- \$41,336 less for power/cooling
- \$71,624 less for floor space

Saves client \$112,960

New airflow design is also more energy efficient

Front-to-back airflow for hot-aisle-cold-aisle data centers

- More data centers are moving to hot aisle / cold aisle designs to optimize energy efficiency
- DS8800 is now designed with complete front-to-back airflow

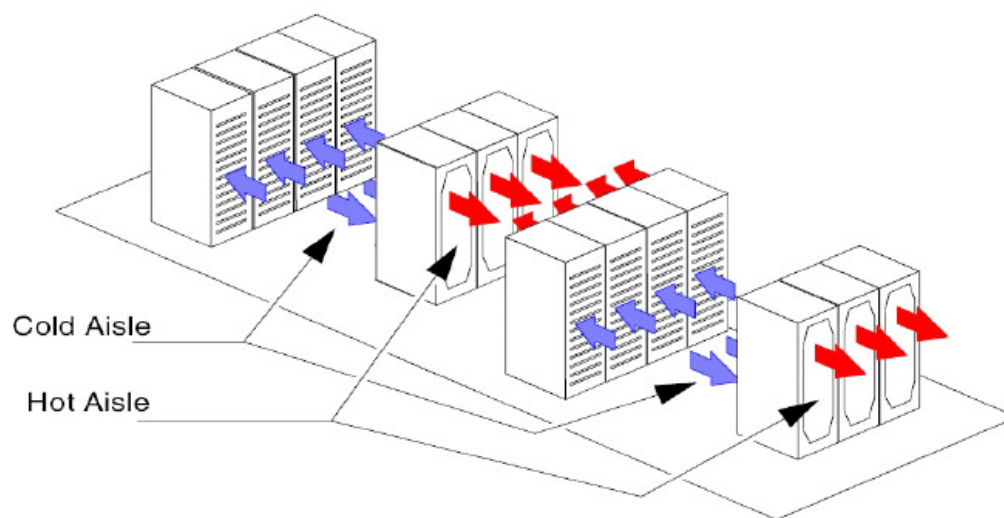

Benefit: Greater energy efficiency and contributes to lower energy costs

Business Class cabling option

Higher drive counts per adapter for better utilization

- Most clients don't use maximum configured systems
 - Supporting more drives per adapter lets smaller systems scale more efficiently
 - Reduces required hardware for smaller configurations
 - Almost double the drives in same frame footprint compared to standard cabling for 2-way systems

- Benefits
 - More drives supported for 2-way systems in base frame
 - Smaller footprint for small to mid size systems up to 240 drives, allowing better hardware utilization
 - Supports single phase power

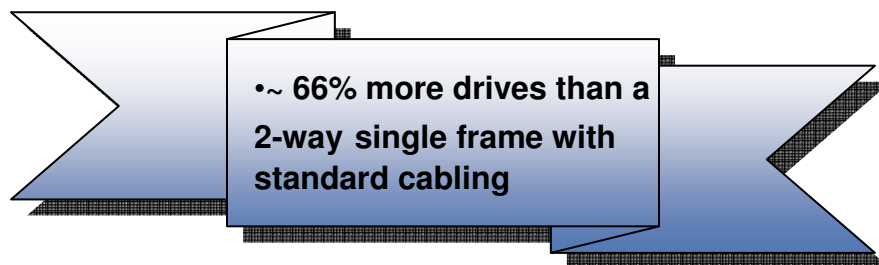

Perfect for System z BC environments

High Availability Volume Management with TPC for Replication v4.2

Open HyperSwap for IBM AIX environments

- **Ability to swap IBM DS8000 volumes in seconds**
 - Can be command driven or can be automated upon a storage system failure
 - Designed to scale to multi-thousands of volumes
- **Switches Metro Mirror primary storage system to the secondary storage system**
 - No operator interaction is needed for event driven operation
 - Function is configured and managed by TPC-R
- **Feature is non-disruptive**
 - Applications keep using same device addresses
- **Integration with AIX 5.3 (or later) provides higher availability for AIX environments**

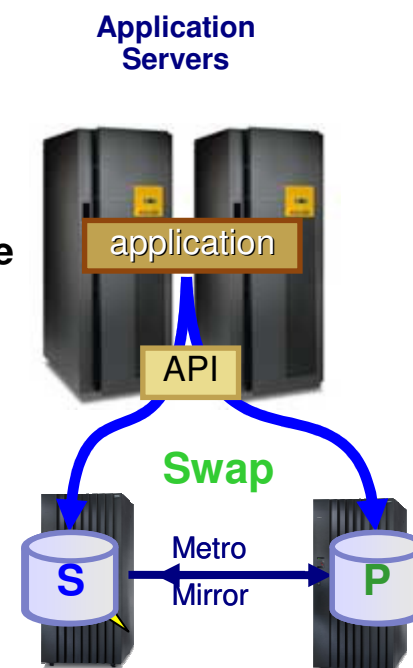

Available on TPC-R Windows, AIX, Linux and z/OS installations with the TPC-R 2 Site BC License

Tivoli Key Lifecycle Manager v2.0

Advanced security for data at rest

- New features for TKLM V2.0
 - KMIP – Key Management Interoperability Protocol V1.0 standard from OASIS
 - Partners include Emulex, Brocade,...
 - RBAC – Role Based Access Control
 - Grouping of permissions
 - Grouping of Devices
 - Grouping of Administrators
 - Who can do what action
 - What device can see what keys
- Continues with Ease of Use, simple install and administration
 - Key store, key serving, key rotation, auditing

IBM is rated in the top 5 of
 “Most Trusted Companies
 in [Data] Privacy”*

If your information
 isn't secure, your
 business isn't safe.



The DS8800 announcement introduces the most advanced model in our high-end disk portfolio with another increase in performance, greatly improved energy efficiency, and almost double the capacity in the same footprint.

This new model not only offers the ability to process information faster and more efficiently, it also builds on the DS8700's foundation of unrivaled reputation for customer proven reliability, performance and disaster protection by maintaining DS8000's base microcode architecture and its market-proven, IBM POWER-based architecture over generations of new models.

Announce date is October 7, 2010

Ship Support date is October 22, 2010

General Availability date is November 19, 2010

Thank You!

Trademarks and Disclaimers



IBM Corporation 1994-2010. All rights reserved.

References in this document to IBM products or services do not imply that IBM intends to make them available in every country.

Trademarks of International Business Machines Corporation in the United States, other countries, or both can be found on the World Wide Web at <http://www.ibm.com/legal/copytrade.shtml>.

Intel, Intel logo, Intel Inside, Intel Inside logo, Intel Centrino, Intel Centrino logo, Celeron, Intel Xeon, Intel SpeedStep, Itanium, and Pentium are trademarks or registered trademarks of Intel Corporation or its subsidiaries in the United States and other countries.

Linux is a registered trademark of Linus Torvalds in the United States, other countries, or both.

Microsoft, Windows, Windows NT, and the Windows logo are trademarks of Microsoft Corporation in the United States, other countries, or both.

UNIX is a registered trademark of The Open Group in the United States and other countries.

Java and all Java-based trademarks are trademarks of Sun Microsystems, Inc. in the United States, other countries, or both.

Other company, product, or service names may be trademarks or service marks of others.

Information is provided "AS IS" without warranty of any kind.

The customer examples described are presented as illustrations of how those customers have used IBM products and the results they may have achieved. Actual environmental costs and performance characteristics may vary by customer.

Information concerning non-IBM products was obtained from a supplier of these products, published announcement material, or other publicly available sources and does not constitute an endorsement of such products by IBM. Sources for non-IBM list prices and performance numbers are taken from publicly available information, including vendor announcements and vendor worldwide homepages. IBM has not tested these products and cannot confirm the accuracy of performance, capability, or any other claims related to non-IBM products. Questions on the capability of non-IBM products should be addressed to the supplier of those products.

All statements regarding IBM future direction and intent are subject to change or withdrawal without notice, and represent goals and objectives only.

Some information addresses anticipated future capabilities. Such information is not intended as a definitive statement of a commitment to specific levels of performance, function or delivery schedules with respect to any future products. Such commitments are only made in IBM product announcements. The information is presented here to communicate IBM's current investment and development activities as a good faith effort to help with our customers' future planning.

Performance is based on measurements and projections using standard IBM benchmarks in a controlled environment. The actual throughput or performance that any user will experience will vary depending upon considerations such as the amount of multiprogramming in the user's job stream, the I/O configuration, the storage configuration, and the workload processed. Therefore, no assurance can be given that an individual user will achieve throughput or performance improvements equivalent to the ratios stated here.

Photographs shown may be engineering prototypes. Changes may be incorporated in production models.

