

IBM CICS Transaction Gateway V9.0

Recent enhancements

- Java 7 support for client applications
- Increased vertical scaling on z/OS®
- Extended Secure Sockets Layer (SSL) connectivity to 3-tier topologies
- Connection-level time-out with IPIC
- 64-bit support for ECI V2 and ESI V2
- ECI V2 support for asynchronous calls
- End-to-end transaction tracking with the WebSphere® Application Server V8.5
- Simplified topologies for highly-available connections with global transactions
- Historical statistics with CICS® TG for Multiplatforms

Features

- Optimized for WebSphere Application Server, plus channels and containers support for the .NET API for handling larger amounts of data.
- Open integration with extended support for .NET environments
- Extended interoperability and simplified security with CICS TS V4.2 and later
- Integration with CICS Explorer®

Benefits

- Proven connectivity: distributed platforms integrate with any CICS server
- Skills match for today: bridges the skill gap
- Inter-operable: rich programming APIs to drive CICS transactions
- Flexible: from the Desktop Edition through Multiplatform to the z/OS version
- Non-invasive: no changes to CICS applications
- Scalability and availability—secure, scalable, and highly available connectivity
- Instrumentation: monitoring and statistical facilities give insight into workload patterns

The premier IBM connector to CICS

Much of the world's data is processed on mainframes, using the qualities of service of proven transaction servers such as CICS TS. Delivering access to CICS applications through standards-based interfaces is becoming a key requirement in many of today's sophisticated service-oriented solutions.

IBM® CICS Transaction Gateway (CICS TG), a market-leading Enterprise connector, is production proven by over a thousand customers as a high-performing, security-rich, and scalable method of service-oriented architecture (SOA) access to CICS, which:

- Delivers Java Enterprise Edition (JEE) standards-based access to CICS applications, while requiring minimal changes to CICS and usually no changes to existing CICS applications
- Provides quick and easy connector access to CICS applications from a wide variety of environments, including Java, C/C++, Microsoft .NET, and COBOL run times
- Allows the reuse of existing CICS applications as services in comprehensive and sophisticated JEE and web services solutions hosted on powerful application servers such as WebSphere Application Server

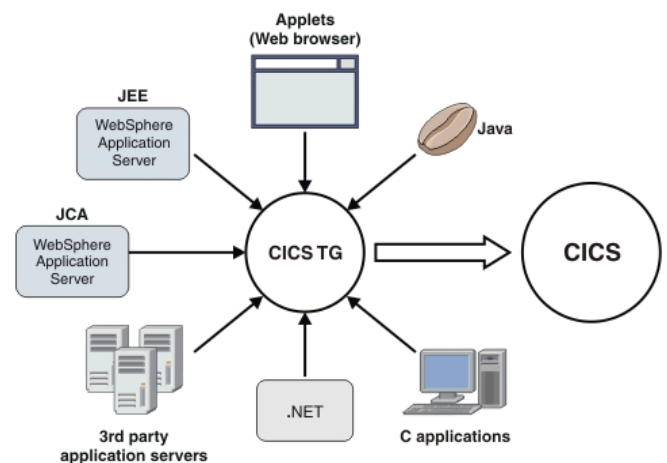

Figure 1 CICS TG topologies

Implementing CICS TG requires minimal changes to CICS systems and usually no changes to CICS applications. CICS TG is available on a range of platforms and can be deployed in a number of different topologies (see Figure 1).

CICS TG supports common programming frameworks allowing a wide variety of application platforms to securely integrate with CICS. While Java Connectivity Architecture (JCA) provides the highest qualities of service, such as connection pooling and transaction management, for applications deployed to a JEE application server such as WebSphere Application Server, the CICS TG APIs for Microsoft .NET and C, COBOL, and Java applications allow Windows, UNIX, and Linux platforms to exploit the robust and scalable connectivity available through CICS TG.

CICS TG V9.0 provides significant enhancements over previous releases in the key areas of open integration, high availability, and support for CICS TS V5.1.

The ability to reuse CICS applications in mixed CICS, Java, and other workloads, delivers real business value by increasing system flexibility and by helping to reduce costs.

Deployment options

CICS Transaction Gateway is available in three product options, to best match your requirements.

- CICS TG for z/OS V9.0 provides highly-scalable, multi-user access to CICS TS for z/OS, and is the recommended deployment platform when the highest qualities of service—availability, performance, security, and transactionality—are required.
- CICS TG for Multiplatforms V9.0 delivers scalable, multi-user access to CICS TS for z/OS, CICS TS for VSE, TXSeries, and CICS TS for i. It is an ideal deployment option for less-demanding environments, or when managed by distributed system administrators.
- CICS TG Desktop Edition V9.0 provides low-cost, single-user access to CICS. It includes all the function of CICS Universal Client V7.1 with the addition of the latest operating system and compiler support.

External Call Interface (ECI) applications developed for use with CICS TG Desktop Edition can be deployed as remote client applications using CICS TG for Multiplatforms or CICS TG for z/OS.

See Table 1, in the specifications section at the end of this data sheet, for a detailed comparison of the three different products.

Open integration

CICS TG provides extended support for Java Enterprise Edition (JEE) application servers and Windows .NET environments. CICS TG is the

premier connector for integration with WebSphere Application Server, and is optimized for use with WebSphere Application Server on host and distributed systems.

JEE integration

CICS TG V9.0 supports any JEE 6 certified application server, and is backward compatible with J2EE 1.4 and JEE 5 application servers. Exploitation of the enhanced JCA 1.6 specification (part of JEE 6) enables a single CICS TG resource adapter to provide both one-phase and two-phase commit support, reducing confusion about which resource adapter to pick, reducing maintenance overheads, and increasing flexibility in deployment.

A JEE application server installation verification test (IVT). This allows simple verification of the CICS JCA resource adapters for usage in any application server that complies with the J2EE 1.4 specification.

.NET support

CICS TG APIs are usable in a wide variety of client runtime environments, including Microsoft .NET, COBOL, and C++. CICS TG enables a broad range of .NET applications, for example C# or Visual Basic .NET clients to connect to CICS through the ECI API in remote mode topologies. CICS TG V9.0 clients are interoperable with 32-bit and 64-bit .NET compilers and runtime environments.

Powerful APIs

The CICS TS channels and containers programming model provides a simple method for CICS TG applications to exchange data with CICS programs, in amounts that far exceed the 32 KB limit that applies to the COMMAREA, and additionally provides an optimized and more structured data interface. In CICS TG V9.0 the .NET remote client ECI API provides support for the CICS TS channels and containers programming model.

The ECI Version 2 API can be used in a wide variety of client runtime environments, including Microsoft.NET, COBOL, and C++, and extends the capability for migration of CICS Universal Client ECI applications to a lightweight client footprint.

Java

CICS TG can operate in local mode within 64-bit Java runtime environments. Support is provided through the ECI resource adapters and enables a direct IPIC connection to a CICS server in a 2-tier

environment. This provides enhanced compatibility and scalability for local deployment with 64-bit JEE application servers, such as WebSphere Application Server for Multiplatforms.

Java applets can also access CICS TG, using the Secure Sockets Layer (SSL), encrypted SSL, or Transport Layer Security (TLS) connections to a remote Gateway daemon, supporting encryption and authentication capabilities and better interoperability with a variety of secure clients.

Enhanced IPIC connection support

Customers wishing to standardize on modern networking protocols can benefit from the CICS Internet Protocol Inter-connectivity (IPIC) support available with CICS TG.

In the event that connections to CICS servers fail, it is important that the CICS TG is able to detect and respond to such failures quickly. A customizable server retry interval for IPIC connections shortens time-to-failure, allowing faster fail-over to an alternate CICS server when used with dynamic server selection in a high availability configuration.

Security

CICS TG provides a range of security mechanisms to provide end-to-end security solutions, including SSL, identity propagation and user authentication.

The External Security Interface (ESI) API is available from ECI V2 and .NET applications and ESI requests can also be used with IPIC connections.

CICS TG supports password phrases with both the ECI and ESI APIs when connecting to CICS TS V4.2 and above using IPIC connections. Password phrases allow longer and more complex strings of mixed-case characters to be used to authenticate a user ID and can provide improved system protection since they are less likely to be guessed and require more processing power to sustain an attack.

CICS TG V9.0 now supports SSL connectivity with IPIC connections in 3-tier (or remote mode) topologies, allowing secure end-to-end connectivity for CICS TG applications, regardless of deployed topology.

Availability and scalability

CICS TG provides a number of options for implementing highly available and scalable environments. With CICS TG for z/OS, it is possible to create a sysplex-wide highly available Gateway solution incorporating XA transactions,

maintaining transactional scope with CICS systems across the IBM Parallel Sysplex® while ensuring that confidence in system up-time is maximized (see Figure 2).

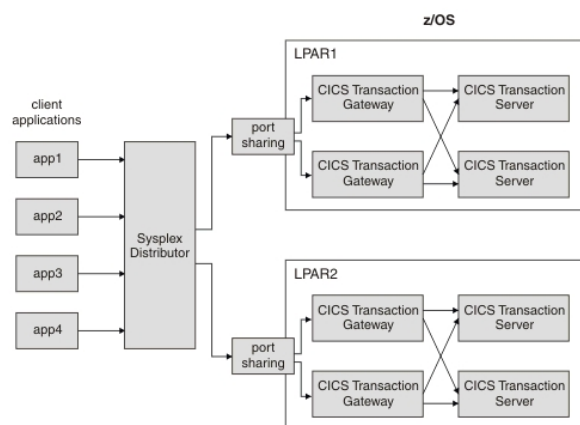

Figure 2 CICS TG for z/OS high availability

Dynamic server selection

CICS TG for z/OS supports dynamic server selection for all types of ECI requests, including two-phase commit requests using the XA protocol. Policy-based, configurable dynamic server selection, provides out-of-the-box high availability support for ECI and ESI workloads, and a simplified mechanism for creating CICS high availability solutions that do not require the provision of user exit code.

CICS request exit

High availability on distributed platforms is implemented using the CICS request exit with CICS TG for Multiplatforms, and CICS TG Desktop Edition. CICS SupportPac CA1T provides a working sample CICS request exit for deployment into the Gateway daemon, enabling remote Java, Microsoft .NET and ECI V2 clients to exploit a CICS high availability infrastructure.

AIX Workload Partitioning

CICS TG V9.0 supports the use of IBM AIX virtualization through Workload Partitioning (WPAR), for client applications and for CICS TG daemon processes. CICS TG supports using application WPARs for client applications in remote mode or, where the IPIC protocol is used, in local mode.

CICS TG V9.0 exploits 64-bit Java 7 increasing overall capacity per Gateway daemon, enabling customers to consolidate and simplify deployment topologies and reduce system management overheads. Exploitation of 64-bit storage allows CICS TG V9.0 to carry more work with larger payloads than ever before.

Transaction tracking

CICS TG enables end-to-end tracking of requests across the enterprise, tracking a user request from its point of origin all the way across the CICSplex. JEE, Java clients and ECI V2 applications propagate origin metadata to CICS using IPIC connections, enabling correlation of work flows from their end user right through to the system. CICS TG V9.0 can exploit the new Cross Component Trace feature of WebSphere Application Server V8.5, providing end to end audit and diagnostic capabilities. Transaction tracking can quickly identify where to concentrate attention in problem determination and also facilitate roundtrip, performance optimization.

CICS Explorer integration

The CICS Explorer is the recommended systems management tool framework for CICS, for use with CICS TS V3, V4, and V5.

The CICS Explorer provides an intuitive, easy-to-use way of managing one or more CICS regions. A plug-in for the CICS Explorer provides the ability to manage Gateway daemons at version V7.1 or later on any platform. Recent updates to the plug-in provide an improved set of views and customizations, together with integrated connection management and built-in Gateway and CICS test functions.

For more information about IBM CICS Explorer, see: ibm.com/cics/explorer.

Performance and availability monitoring

CICS TG records usage statistics, enabling capacity planning and performance monitoring. CICS TG for z/OS writes statistics to z/OS System Management Facilities (SMF) using an SMF type-111 record for in-depth, offline analysis using IBM CICS Performance Analyzer for z/OS. CICS TG for Multiplatforms and Desktop Edition both write statistics in XML format to local files.

In addition, IBM Tivoli® OMEGAMON® XE for CICS on z/OS uses the monitoring function in CICS TG for z/OS to support real-time performance management, monitoring and troubleshooting with charts, alerts, advice, and automated scripts.

Scenario: Bank branch offices

A major national bank with thousands of branch offices, tens of thousands of connected users, and with stringent quality of service requirements. The bank uses desktop ECIV2 client applications, written in C/C++, to access home-grown core-

banking applications running on CICS TS for z/OS using CICS TG for z/OS.

Scenario: Insurance package access

An insurance company uses a vendor-provided JEE-based package deployed using WebSphere Application Server on AIX to provide branch and direct customer access to front-office systems for customer and order management. The package connects to CICS-based, back-office, policy-management applications with full transactional integrity using CICS TG for Multiplatforms.

Scenario: Retail chain

A large chain of retail stores uses CICS TG Desktop Edition to run ECI applications to connect directly to CICS. Using remote clients to connect to a centralized CICS is useful approach, where networks might be unreliable.

CICS Tools — your pathway to success

CICS Transaction Gateway, an IBM CICS Tool, can help you to exploit and augment the latest operational efficiency and service agility enhancements in CICS TS V5.1 in a way that positions you for the next transformational era in technology, moving towards a service delivery platform for cloud computing.

CICS Tools can help you to optimize your CICS resources and achieve greater capacity and improve the availability of your critical enterprise systems. Their powerful automation capabilities can speed service delivery, improve standardization, and reduce risk, while rich discovery, advanced visualization, and comprehensive reporting provide the insight needed to ensure that your applications run smoothly and changes are efficient and reliable.

Support for the application and platform resources introduced in CICS TS V5.1 help you to achieve value from the new version of CICS more quickly. CICS tools include modern interfaces integrated with CICS Explorer, helping both new and experienced IT personnel to be more productive with minimal training delay. Foundational enhancements continue to extend the tools capabilities in many areas.

For more information

Contact your IBM representative or IBM Business Partner or visit: ibm.com/cics/ctg

To learn more about other IBM CICS Tools, visit: ibm.com/cics/tools

CICS Transaction Gateway V9.0				
Features		Desktop Edition	for Multiplatforms	for z/OS
Number of users		Single-user	100s to 1000s	1000s +
Programming interfaces		ECI, EPI, ESI	ECI, EPI, ESI	ECI, ESI
Programming languages		Java, .NET, C/C++, COBOL	Java, .NET, C/C++, COBOL	Java, .NET, C
Networking options		TCP/IP, IPIC, SNA	TCP/IP, IPIC, SNA	EXCI
Request monitoring and statistics functions		Y	Y	Y (With CICS PA, OMEGAMON XE, or both)
Application Servers		.NET only	.NET, JEE	.NET, JEE
CICS Explorer		Y	Y	Y
Application style		Desktop	Desktop Application server	Desktop Application server
Operating systems	Client	Windows, Linux, UNIX	Windows, Linux, UNIX	Windows, Linux, UNIX
	Gateway	Windows, Linux, UNIX	Windows, Linux, UNIX	z/OS
2-phase commit		N	JCA (XA)	JCA (XA)
High Availability		Dynamic server selection (User exit) Windows workload manager	Dynamic server selection (User exit) Windows workload manager	Dynamic server selection (Out of the box)

Table 1 CICS Transaction Gateway product comparison

IBM CICS Transaction Gateway V9.0

At a glance

Hardware requirements

CICS TG V9.0 runs on any of the following hardware, supported by an operating system listed below:

- z/OS: IBM System z
- AIX: IBM System p® machine supported by IBM AIX
- Linux: Intel Pentium IV or later processor, Intel x86-64 or AMD x86-64 processor; 64-bit IBM System p machine supported by Linux; IBM System z machine supported by Linux
- Microsoft Windows: Intel Pentium IV or later processor, Intel x86-64 or AMD x86-64 processor supported by Microsoft Windows
- Oracle Solaris: 32-bit or 64-bit SPARC system supported by Oracle Solaris Operating Environment
- HP-UX: 64-bit HP Itanium

Software requirements

Supported operating systems

- z/OS V1.12, or later
- AIX V6.1, or later
- Linux on System z: Red Hat Enterprise Linux (RHEL) 5, RHEL 6, SLES 10, or SLES 11 (with 64-bit kernel)
- Linux on Intel: RHEL 5 or RHEL 6 compatible environments*
- Microsoft Windows Vista, Windows 7 Business, Professional, Enterprise and Ultimate Editions (with 32-bit or 64-bit kernel)
- Microsoft Windows 2008 Standard (including Small Business Server), Enterprise and Datacenter Editions (with 32-bit or 64-bit kernel)
- Microsoft Windows 2008 R2 Standard (including Small Business Server), Enterprise and Datacenter Editions (with 64-bit kernel)
- Oracle Solaris V10 (with 32-bit or 64-bit kernel)
- HP-UX11i V2 or V3 (with 64-bit kernel) on Itanium

Supported CICS systems

CICS Transaction Gateway is designed to provide interoperability with all supported levels of CICS. The following list summarizes the CICS servers currently supported by IBM:

- CICS Transaction Server for z/OS V3.1, or later
- TXSeries for Multiplatforms V6.1, or later
- IBM CICS Transaction Server for VSE/ESA V1.1.1
- IBM CICS Transaction Server for i5/OS™ V5.4, or later
- IBM CICS Transaction Server for i V7.1

Supported application servers

Not applicable to CICS Transaction Gateway Desktop Edition.

- IBM WebSphere Application Server V8.0
- Other JEE application servers that are JEE 6 certified compliant. Use the Installation Verification Test (IVT) provided with CICS Transaction Gateway V9.0 to check if a specific JEE application server can be used.
- JEE application servers that are J2EE 1.4 certified compliant are supported in remote mode with the CC03 SupportPac.

Full details of the hardware and software requirements CICS Transaction Gateway can be found at: ibm.com/cics/ctg/reqs

IBM United Kingdom Limited
Hursley Park
Winchester
Hampshire
UK SO21 2JN
United Kingdom

© Copyright IBM Corporation. 2010, 2012. US Government Users Restricted Rights - Use, duplication or disclosure restricted by GSA ADP Schedule Contract with IBM Corp. IBM, the IBM logo, ibm.com, and CICS, CICS Explorer, i5/OS, OMEGAMON, Parallel Sysplex, System p, System z, Tivoli, WebSphere, and z/OS are trademarks of IBM Corporation, registered in many jurisdictions worldwide. Java and all Java-based trademarks and logos are trademarks or registered trademarks of Oracle and/or its affiliates. Linux is a registered trademark of Linus Torvalds in the United States, other countries, or both. Microsoft, Windows, and the Windows logo are trademarks of Microsoft Corporation in the United States, other countries, or both. UNIX is a registered trademark of The Open Group in the United States and other countries. Pentium is a trademark or registered trademark of Intel Corporation or its subsidiaries in the United States and other countries. Other product and service names might be trademarks of IBM or other companies. A current list of IBM trademarks is available on the Web at "Copyright and trademark information" www.ibm.com/legal/copytrade.shtml.



GI13-0598-00