

Understand how the new features
in CICS IP interconnectivity can
help your business

August 2011



IBM CICS IP interconnectivity: New features in Version 4.2

*Phil Wakelin, Technical strategist, CICS Transaction Server
Mike Brooks, Developer, CICS Transaction Server*



CICS icon of progress: <http://www.ibm.com/ibm100/us/en/icons/cics/>

Executive summary

CICS® Transaction Server for z/OS® (CICS TS) continues to evolve as a highly optimized transaction-processing environment with a flexible and adaptable network-communications framework. As part of this strategy, CICS TS Version 4.2 delivers extended capabilities for IP interconnectivity (IPIC), and now supports sending Distributed Programming Links (DPL), External Call Interface (ECI) requests, 3270 transaction routing, function shipping, and START requests across an IP network connection. As a result, the majority of CICS distributed processing functions can be migrated from SNA to TCP/IP networking, with the associated benefits of simplified administration and lower operating costs provided by network modernization.

The use of IPIC delivers a number of advantages over existing VTAM® intersystem communication, including improved scalability and the provision of new facilities for monitoring, security, and problem determination. Future versions of the CICS family will continue to address the need to further extend IPIC support to provide robust and comprehensive intercommunication support between CICS systems and other System z® software components. By contrast, CICS multi-region operation (MRO) provides optimized networking capabilities for use between systems running in the same z/OS sysplex. IPIC is not intended as a replacement for the MRO facilities that provide optimized intercommunication facilities in a sysplex, although it might be appropriate to migrate some specific applications from MRO to IPIC to exploit the added value that IPIC provides.

Introduction: From SNA to TCP/IP

IBM® Systems Network Architecture (SNA) describes a complete protocol stack for interconnecting computers and their resources, and through the function of the Virtual Telecommunications Access Method (VTAM) component of IBM Communications Server has provided reliable and efficient networking for CICS for over 30 years. SNA is still widely used by many enterprises and has been implemented on many operating systems (see Figure 1).

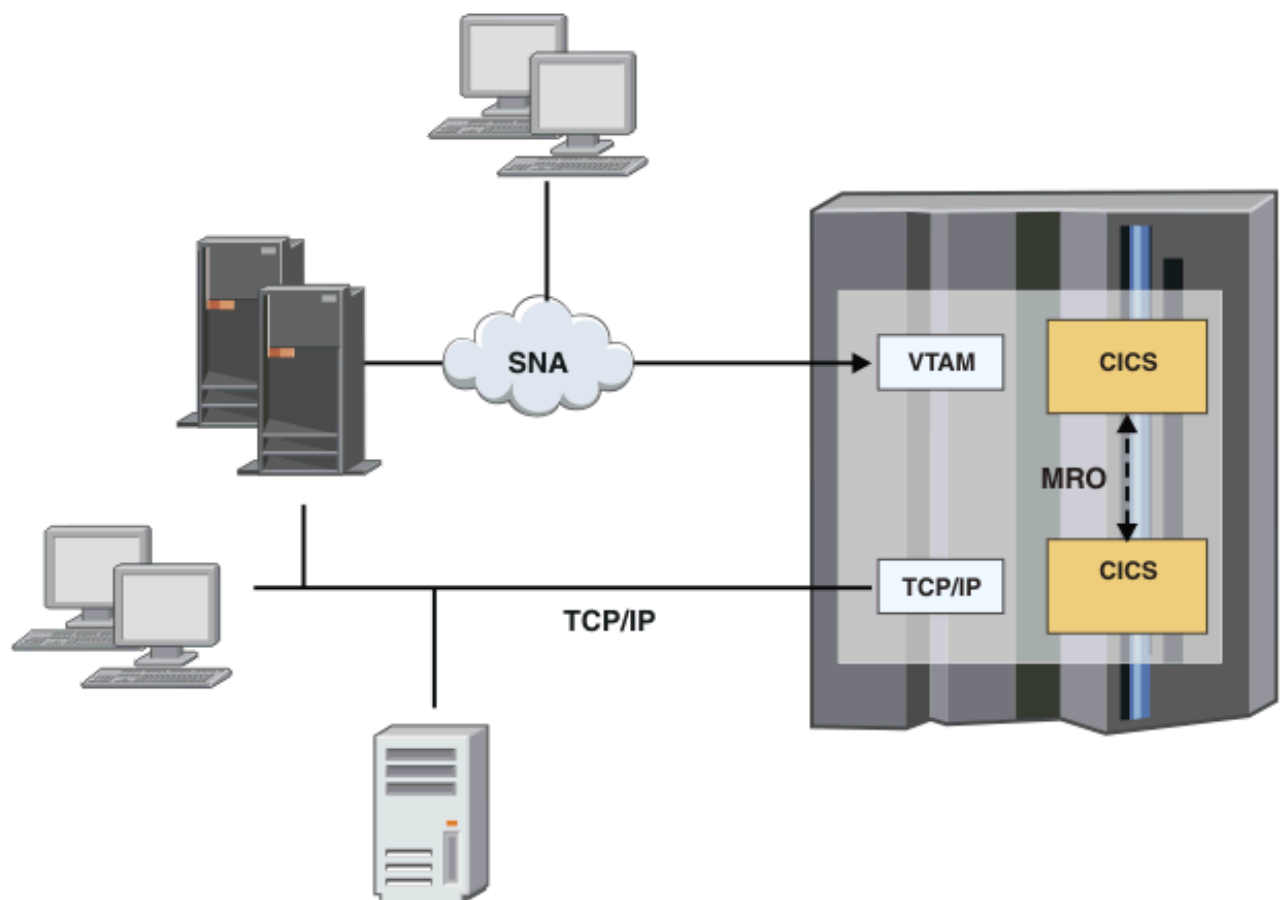

Figure 1. SNA and TCP/IP as network choices for System z

The data formats and protocols used by CICS intersystem communication (ISC) allow intercommunication with remotely connected systems using local or wide area networks based on SNA. This intercommunication includes remote CICS systems on a variety of operating systems, ranging from IBM z/OS to Microsoft Windows, and remote IBM IMS™ systems.

By contrast, CICS multi-region operation (MRO) provides optimized networking capabilities for use between systems running in the same z/OS sysplex. Support is based either on specialized cross-memory services or through the use of a Parallel Sysplex® coupling facility.

TCP/IP, by comparison, provides a standardized and flexible network communications framework, which is supported on virtually all operating systems and by many skilled professionals and tools. The TCP/IP protocol suite has become the foundation for the set of technologies that form the basis of the modern Internet, and has allowed many enterprise networks to benefit from advances in networking technology, such as those provided by multi-gigabit Ethernet networks.

CICS and IP interconnectivity

With CICS TS 4.2 the majority of interconnectivity functions previously supported via SNA and MRO are now also supported over TCP/IP communications links, allowing TCP/IP networking to be adopted across System z enterprise networks. This capability is known as *IP interconnectivity (IPIC)* and the function available with different CICS TS and TXSeries releases is summarized in *Table 1*. Support from IPIC is comparable to that provided for requests transmitted over ISC, with similar controls for user authentication, and support for the exchange of either COMMAREAs, or containers and channels, and built-in syncpoint controls for maintaining transactional integrity.

| <i>Interconnectivity function</i> | <i>CICS TS 3.2</i> | <i>CICS TS 4.1</i> | <i>CICS TS 4.2</i> | <i>TXSeries 7.1</i> |
|--|---------------------------|---------------------------|---------------------------|----------------------------|
| ECI requests via the CICS Transaction Gateway | Yes | Yes | Yes | Yes |
| 3270 transaction routing | No | Yes | Yes | No |
| Asynchronous processing (STARTs and CANCELs) | No | Yes | Yes (enhanced routing) | No |
| Distributed Program Link (DPL) | Yes | Yes | Yes | Yes (sync level 1 only) |
| Function Shipping (of TS, TD and file control) | No | No | Yes | No |

Table 1: IPIC functionality by CICS release with TXSeries

IPIC support across the CICS family

The implementation of IPIC in CICS TS is based on the established support for TCP/IP through the CICS sockets domain, and has been used widely for a variety of CICS connectivity protocols for several releases. The following CICS products provide IPIC functionality:

CICS Transaction Server for z/OS

CICS TS 4.2 IPIC interconnectivity provides support for the function shipping of file control, temporary storage (TS), and transient data (TD) requests between CICS regions. This is in addition to the 3270 transaction routing, distributed program link (DPL), and asynchronous processing already supported in prior releases.

Additionally, CICS TS 4.2 provides the following benefits in the areas of scalability and workload management when using IPIC support:

- Support of enhanced routing for terminal-based STARTs when using CICSplex® System Manager (CICSplex SM) dynamic routing.
- Improved scalability for function-shipped requests through improvements in CICS multi-threading support, and via the option for requests to reuse a long-running mirror task in a remote region.
- Ability to define unit-of-work (UOW) based affinities when using CICSplex SM to dynamically route DPL requests, simplifying the ability to create high availability CICSplex configurations.
- Ability to dynamically route requests over IPIC links in preference to SNA links when using the CICSplex SM goal or queue routing algorithms, ensuring better performance when TCP/IP connections are available across an enterprise.

The new CICS Explorer™ system management interface can be used in conjunction with CICS regions in a CICSplex to:

- Dynamically correlate inter-related CICS tasks in different CICS systems connected via IPIC or MRO connections, through the use of point of origin data.
- Track inter-related tasks using the IP address that is being used by an IPCONN or TCPIP SERVICE resource.

Although IPIC now supports the majority of commonly used ISC interconnectivity functions, the following functions are not available in CICS TS 4.2 IPIC support:

- CMAS to CMAS interconnectivity when using a CICSplex
- Support for APPC or CPIC based applications using CICS DTP
- Support for non-3270 transaction routing such as LU0 devices or LU6.2 sessions

TXSeries

IBM TXSeries for Multiplatforms Version 7.1 is the first release of TXSeries to provide support for IPIC. It permits one-phase commit DPL or ECI requests to be sent and received over an IPIC connection. TXSeries has the following IPIC features:

- Support for channels and containers and traditional DPL requests that use a COMMAREA
- Encryption and authentication support using Secure Sockets Layer (SSL)
- Management of IPIC resources using the TXSeries Web-based administration user

interface

- Support for the dynamic routing of requests using the TXSeries workload manager

CICS Transaction Gateway

Access to CICS from remote client applications is provided through the facilities of the External Call Interface (ECI) provided by IBM CICS Transaction Gateway (CICS TG). Using the ECI enables a wide variety of applications, including Java, C, or .NET clients, to invoke business functions within CICS applications.

Starting with CICS TG 7.1, ECI requests can now use IPIC links to connect to applications in CICS TS or TXSeries. Usage of IPIC provides enhanced capabilities over those provided with other existing protocols, with the following key benefits:

- Support for the CICS channels and containers programming model
- Improved sysplex-wide high availability when using XA
- Additional security options, including SSL connections directly into CICS and support for RACF® identity propagation with CICS TS
- Improved transaction tracking, through the addition of the originating client IP address and CICS TG point of origin to the CICS task association data
- XA two-phase commit connections without a Gateway daemon
- Additional 64-bit client application support scenarios
- Increased session limits compared to the use of the EXCI interface to CICS MRO

Connections

Although migration to IPIC should not necessitate application changes, it is important to realize that the resource definitions used by CICS are different (see Figure 2).

ISC resource definitions

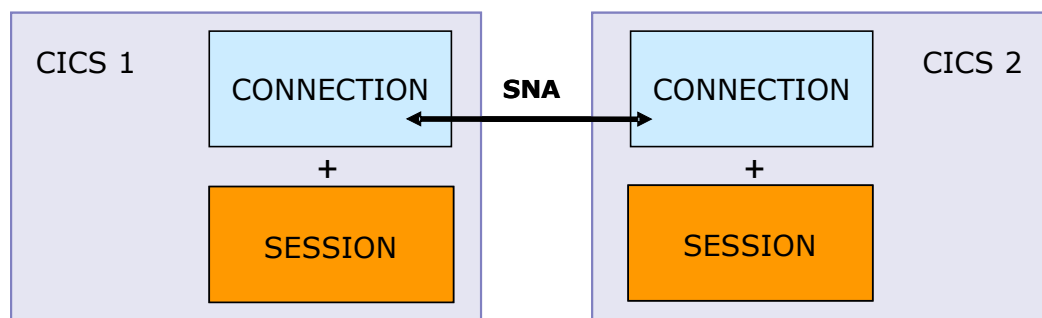

IP interconnectivity resource definitions

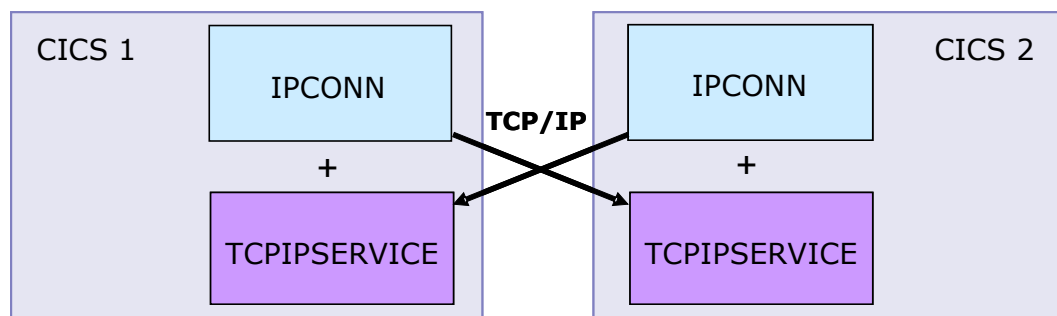

Figure 2. ISC and IPIC resources

ISC requires CONNECTION and SESSION resources, whereas IPIC requires an IPCONN resource. The IPCONN resource definition controls the properties of both the send and receive sessions and the related facets, such as security or queuing. In addition, the ability of the CICS region to listen on a given TCP/IP port is controlled through a TCPIP SERVICE definition that is specific to a given TCP/IP access protocol. A sample CICS tool has been provided to assist in the creation of the IPCONN and TCPIP SERVICE resource definitions based on the CONNECTION and SESSION resources that were used in a non-IPIC environment.

Benefits of IPIC

The new IPIC support delivered by CICS TS 4.2 offers a replacement for the current SNA based ISC support and is now available for the majority of CICS interconnectivity applications. It is not intended to replace the MRO facilities that provide optimized intercommunication facilities within a sysplex, although some installations may wish to migrate specific applications from MRO to IPIC in order to exploit the added value IPIC provides (see Figure 3).

IPIC not only offers similar capabilities and qualities of service to those provided by ISC but also builds on the unique value of System z IP networking enhancements to provide the following added benefits:

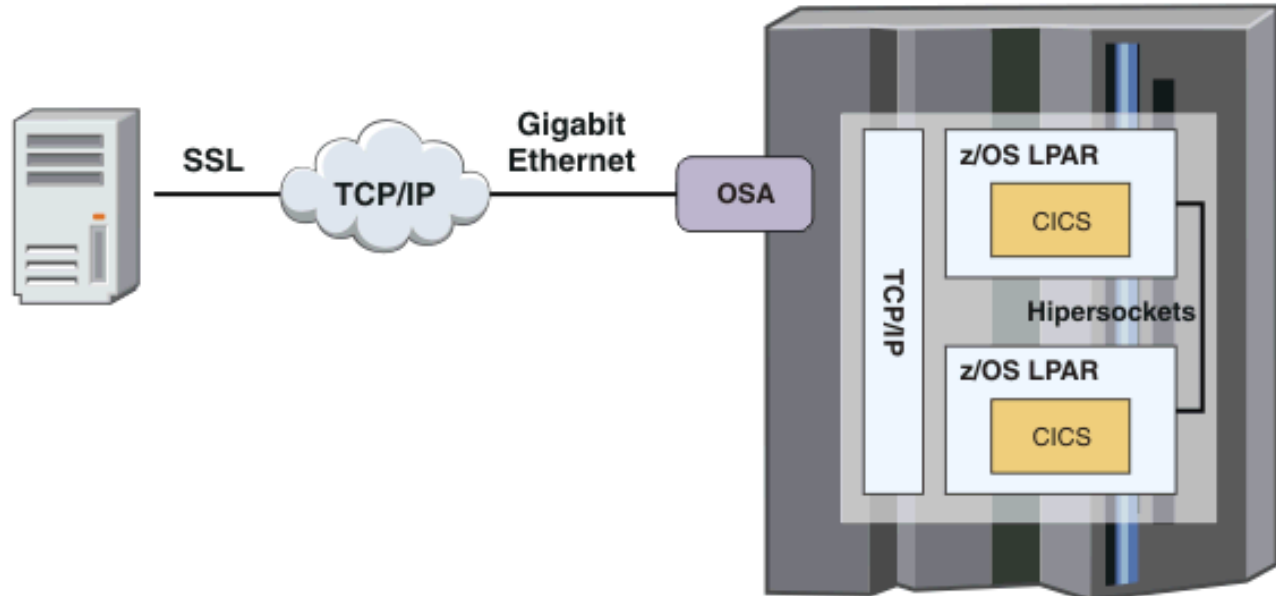

Figure 3. IPIC use of TCP/IP networking

- Improved encryption and authentication between CICS regions through the function of Secure Sockets Layer (SSL)
- Greater security control of the IP services through the Communications Server facilities for STACKACCESS and PORTACCESS control,¹ and NETACCESS zones.
- Use of specialized Open Systems Adapter-Express (OSA-Express) hardware for the exploitation of modern high capacity multi-gigabit Ethernet networks
- IBM HiperSockets™ network facilities for cross-memory, high-speed networking between logical partitions (LPARs) that are located on the same physical server
- Offload of CPU to speciality zIIP processors when using container payloads over 32 KB across Hipersocket connections
- Exploitation of VIPA¹ (Virtual IP Address) technology that decouples the IP address from the physical adapter, allowing an IP address to be easily moved around the sysplex

Looking forwards

There are two goals of modernizing a CICS network. The first goal is to avoid the need to modify application programs. Because the majority of CICS applications are not themselves based on SNA, they should transition easily from running in an SNA network environment to running in a TCP/IP environment. The second and long-term goal for CICS IP interconnectivity is to enable the modernization of the enterprise network

¹ For transactional recovery reasons, TCP/IP load balancing technology such as Port Sharing or Sysplex Distributor cannot be used to dynamically balance requests that use IPIC connections.

infrastructure so that all CICS applications can be accessed and can intercommunicate using native TCP/IP networking capabilities.

Today CICS TS supports DPL, ECI, 3270 transaction routing, function shipping, and START requests using IPIC connections. Future versions of the CICS family will continue to address the need to further extend IPIC support to provide robust and comprehensive intercommunication support between CICS systems and other System z software components.

Although SNA is being replaced by IP at the networking level, IBM does not plan to discontinue CICS support for SNA or VTAM. Any SNA-based CICS applications that directly use Logical Unit (LU) 0 or LU 6.2 facilities can continue to be accessed through an IP-based SNA networking technology such as the HPR/IP technology provided by the Enterprise Extender feature of IBM Communications Server.

Conclusion

The TCP/IP-based intercommunication protocol provided by CICS TS 4.2 delivers a number of advantages:

- CICS TS continues to evolve as a highly optimized transaction-processing environment with a flexible and adaptable network-communications framework.
- Migration of SNA networks to IP allows CICS system administrators to put into effect a readily available set of IP-based wide area networks and associated skills, and to benefit from the wide choice of modern IP networking appliances.
- The addition of function-shipping support in CICS TS 4.2 allows the majority of CICS interconnectivity applications to be migrated from SNA to IP networks.
- The new IPIC protocol provides added value over ISC-based VTAM connectivity through improved scalability and the provision of new facilities for monitoring, security, and problem determination.

Further reading

1. IPIC learning path:
<http://publib.boulder.ibm.com/infocenter/cicsts/v4r2/topic/com.ibm.cics.ts.doc/lpaths/ipic/overview.html>
2. *A Structured Approach to Modernizing the SNA Environment* Redbooks® publication:
<http://www.redbooks.ibm.com/abstracts/sg247334.html>

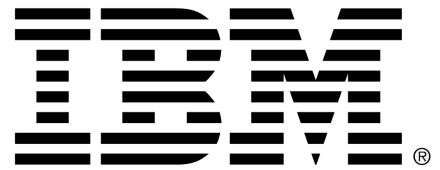

© Copyright IBM Corporation 2011

US Government Users Restricted Rights – Use, duplication or disclosure restricted by GSA ADP Schedule Contract with IBM Corp. IBM, the IBM logo, ibm.com, CICS, CICSplex, CICS Explorer, Hiperspace, Parallel Sysplex, RACF, System z, VTAM, and z/OS are trademarks or registered trademarks of International Business Machines Corp., registered in many jurisdictions worldwide. Other product and service names might be trademarks of IBM or other companies. A current list of IBM trademarks is available on the Web at [Copyright and trademark information at www.ibm.com/legal/copytrade.shtml](http://www.ibm.com/legal/copytrade.shtml). All statements regarding IBM plans, directions, and intent are subject to change or withdrawal without notice.