

Isabelle BRUNEEL

[Isabelle\\_bruneel@fr.ibm.com](mailto:Isabelle_bruneel@fr.ibm.com)

IMS Technical Sales IBM Software Group



# Solutions to recover IMS Data



## Agenda

- **Introduction**
- **IMS resources for recovery – WHAT ?**
- **Timestamp Recovery or Point in Time Recovery – WHEN ?**
- **Recovering IMS DB on local site – HOW ?**
- **IMS/DB2 solutions**
- **Disaster Recovery**

# IMS resources to recover

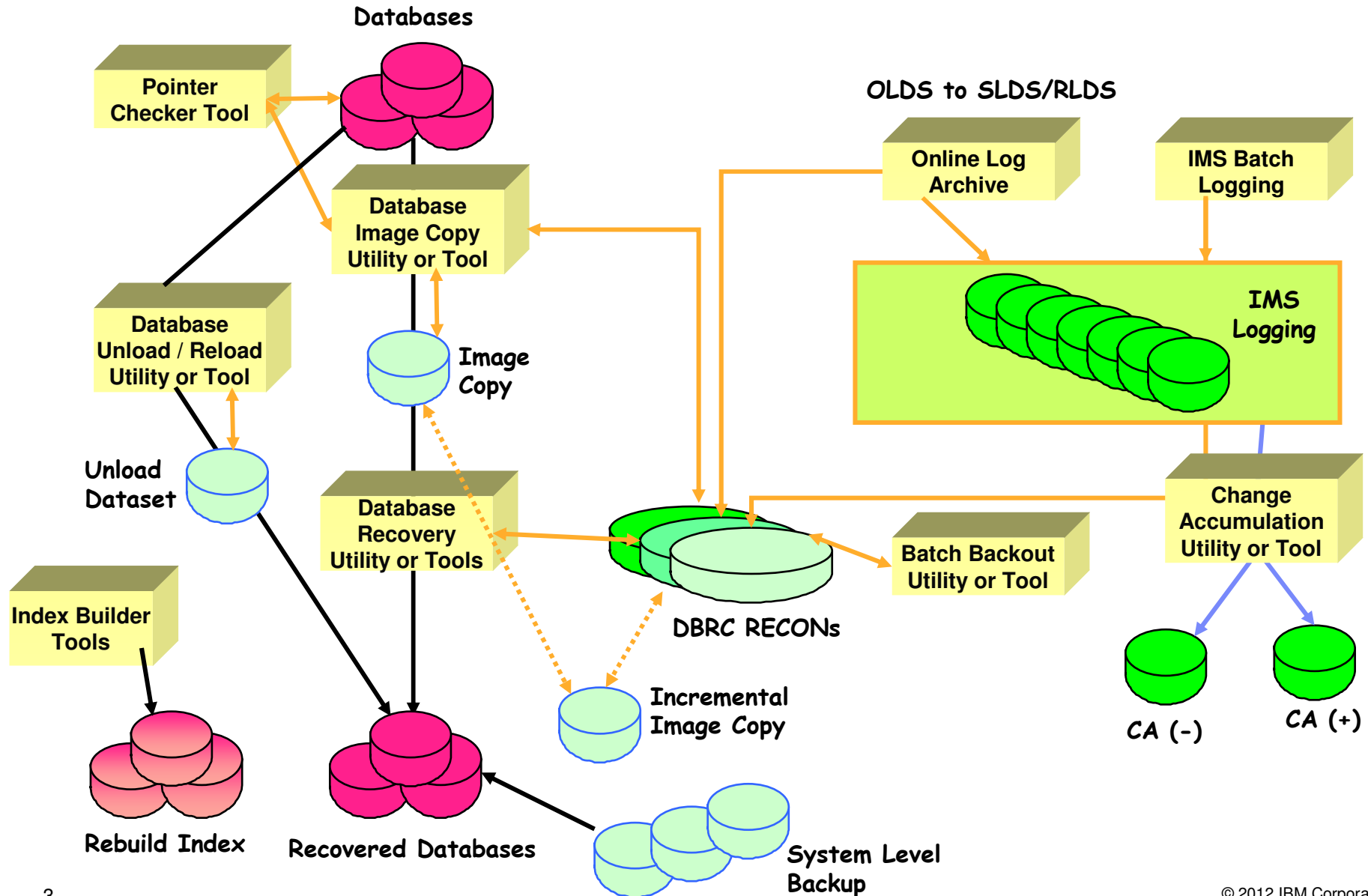

---

## Resources required to recover IMS database dataset

- **Image copies**
  - Backup management
  
- **SLDS / RLDS / CA**
  - Log management
  
- **RECON dataset**
  - Database Recovery Control (DBRC) = Supervisor if Recovery
  - Keep track of logs, CAs, and ICs needed for recovery
  - Holds Recovery Points information
  
- **Unload dataset**
  - May be used when standard recovery fails
  
- **Point In Time to recover**
  - Consistent state of data

## WHAT to backup/recover ?

- **One or several specific databases**
  - FF DBDS
  - Fast Path Areas
  - Index
  
- **One or several groups of databases**
  - DB group / DBDS group / Recovery group
  - Grouping by application
  - Grouping by volumes
  
- **One IMS database/group and one DB2 database/group**
  - if DL/I and SQL in the same UOR, choose coordinated time to recover
  - Any timestamp or recovery point

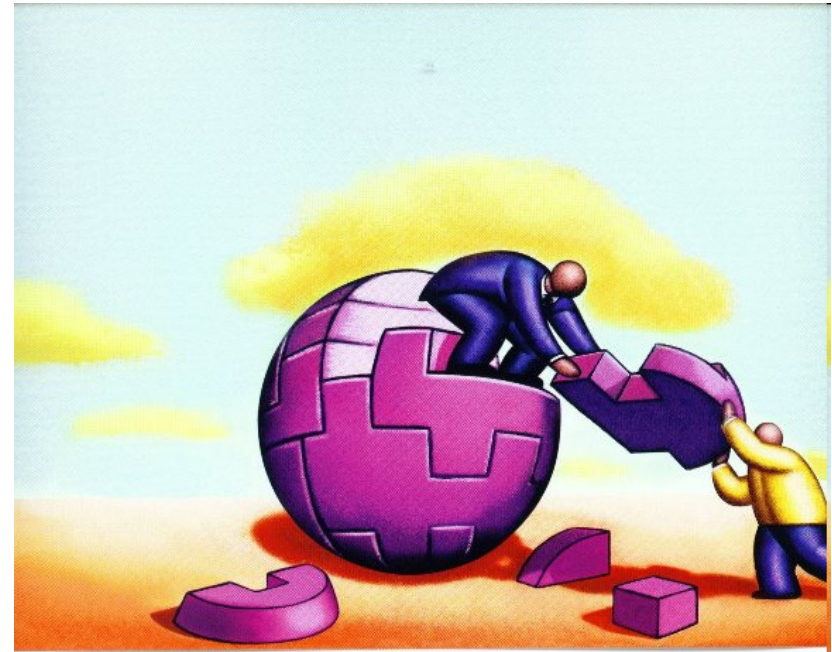

## WHEN to recover ? Which point in time ?

- **To a Recovery Point RP : Timestamp Recovery TR**
  - A RP is a period of time when the database is not allocated
  
- **To any timestamp : Point In Time Recovery PITR**
  - Recover all committed updates to any timestamp
  
- **To the end of the log or Full database recovery**
  
- **Coordinated IMS and DB2 recovery**
  - To the same RP
  - To a Timestamp and coordinated RBA/LRSN
  
- **Which volume of data do you accept to loose ?**
  
- **If broken pointers, consider Unload dataset**



## HOW to backup and recover ?

### ▪ Basic Solution

- IMS commands and/or IMS utilities
  - GENJCL
  - IMS Quiesce
- DB2 Quiesce and/or recover command
- Recovery Readiness Reporter

### ▪ Enhanced solutions

- IMS Recovery Solution Pack including
  - DRF component
  - DRF/XF component
  - **High Performance Image Copy**
  - **IMS Index Builder**
  - High Performance Change Accumulation
- IMS Recovery Expert V2.1
- DB2 Recovery Expert V2.2

### ▪ Storage solutions ( Flashcopy like )



---

## Agenda

- **Introduction**

- **IMS resources for recovery – WHAT ?**

- **Timestamp Recovery or Point in Time Recovery – WHEN ?**

- **Recovering IMS DB on local site – HOW ?**

- **IMS/DB2 solutions**

- **Disaster Recovery**



## Types of backup copy

### ▪ Clean IC vs. Fuzzy IC

- Clean IC or Batch IC to create Recovery Point
  - Database is not available for update for some time  
*/DBR or /DBD or /STA ACCESS RO required or Quiesce DB hold*
  - All segment images are from the same time  
*Recovery may be done without logs*
- Fuzzy IC or ‘Concurrent Image Copy CIC’
  - Database is available for update during the IC process
  - Segment images are from different times  
*Recovery requires logs*

### ▪ Incremental Image Copy

- Offline Image Copy created from a IC and IMS logs updates.
  - Registered in RECON as a clean IC because only committed updates are applied.

### ▪ System Level Backup

- Backup of specific or global datasets / volumes using Storage-based fast-replication ( ex: Flash Copy ). The vast majority of Image copies can be eliminated except the ones required ( following a reorganization )



---

## IMS Image Copy Solutions – From IMS Product

- **Database Image Copy (DFSUDMP0) in a Batch**
  - Clean and fuzzy image copies
  - Fuzzy IC also called “Concurrent Image Copy”
    - Fuzzy IC not valid for VSAM KSDSs
  
- **Database Image Copy 2 Utility (DFSUDMT0) in a Batch**
  - Clean and fuzzy image copies
  - Using DFSMS concurrent copy function (DUMP)
    - Copy multiple database data sets in one execution
    - Copy groups of DBDSs (e.g. DBDSGRP)
  - IMS database data sets supported
    - HDAM, HIDAM, HISAM, DEDB, HALDB
    - OSAM, ESDS, KSDS
  - Will produce 1-4 copies
  - Multiple ICs to single output data set

## IMS Image Copy Solutions – From IMS Product ...

- **Online Database Image Copy (DFSUICP0) in a BMP**
  - Fuzzy image copies
    - Updates allowed only in the same online system

*Limited data sharing support*
  - Runs in online system – special BMP
    - Uses online buffer pools – performance implications
  - Valid for all data set types: OSAM, VSAM ESDS and KSDS
  - Does not support Fast Path databases
  
- **Fast Path DEDB High-Speed Sequential Processing (HSSP)**
  - Fast Path DEDBs only
  - HSSP is an option for BMP application programs
    - High speed process to read the database

*Anticipatory reads eliminate many read waits*
  - HSSP has an image copy option
    - Produces an image copy while application processes the area
    - Fuzzy image copy

*Concurrent updates are allowed in any data sharing system*



## Enhanced IMS Image Copy Solutions – From IMS Tools

- **High Performance Image Copy in a Batch :**
  - Enhanced IC functions to copy a lot of databases in a minimal downtime
  - Works in compatible mode with IMS standard JCL but add:
    - I/O engine to shorten the copy time
    - Can Compress the output
    - Integrate pointer checking and space validation if HP Pointer Checker is there.
  - Works in Native mode with standard IC. Adds to the compatible mode :
    - Possibility to perform several DBD or group of DBD in one JCL step
    - Create copies in //
  - Works in native mode with Advanced Copy Services. Adds :
    - Use storage aware services ( like Snapshot / Flashcopy )
    - Multi database, multi group, copy in //
- **DRF component in Recovery Solution Pack**
  - Provides the Incremental Image Copy function:
    - Apply committed updates from the log datasets to a clean or fuzzy Image Copy
    - Register it in RECON as a Clean IC
- **IMS Recover Expert v2**
  - Provides System Level Backups to recover using a restored dataset
  - Backs up a subset of DBMS (logs, databases) at single point in time in less than 1s
    - Used for Local Application Recovery or Disaster Recovery
  - Intelligent Recovery Manager (IRM) to choose assets for a recovery
  - Determines best recovery resources and method
    - SLB and Image Copies can be combined
    - To Current / Timestamp Recovery (TR) / Point-In-Time-Recovery (PITR)
  - Drives DRF for PITR

## An Unload could be great !

- **High Performance Unload offers the SKERROR option to unload HIDAM, HDAM, PHIDAM, PHDAM, or HISAM databases even if they have incorrect pointer.**
    - It skips incorrect pointers processing, treated as X'00000000' (end of chain),
    - This means that one or more segments are bypassed and are not contained in any output data set.
      - Option 1 (indicated by a 1 in column 28 of the DBD control statement) invokes the Pointer Bypass option using normal retrieval techniques. The usual retrieval methods are as follows:
        - HIDAM and PHIDAM with twin backward on root segment: The primary index is used to find the first root segment. The root twin forward pointer is then followed. If a pointer error is encountered in the root twin forward pointer, HSSR Engine attempts to locate the next root via the primary index.*
        - HDAM and PHDAM: Retrieval begins at the first RAP and follows the root twin forward until a "0" pointer or pointer error is encountered. The retrieval then continues at the next RAP.*
      - Option 2 (indicated by a 2 in column 28 of the DBD control statement) is applicable only to HIDAM and PHIDAM. It forces FABHFSU to use the index (rather than the root twin forward pointers) to unload the database.
- **Reload with IMS standard Reload or High Performance Load.**

## How to identify available resources ?

- **Manually : DBRC commands are great !**
- **Asking for help ? Use RRR Recovery Readiness Reporter**
- **Have you ever ask yourself the following about IC :**
  - What is the image copy frequency in production? Is this automated?
  - Are the jobs scheduled on a regular basis?
  - How often do image copy jobs fail? Is it lack of space or objects not in correct state?
  - What types of backups are being used? DB2 DSN1COPY, FDR, HSM?
  - IMS batch image copy (SHRLEVEL reference), concurrent image copy (SHRLEVEL change), SMS image copies?
  - Is storage team already making volume copies of DB2/IMS data?
  - Are you image copying the same object/database many times a night without you knowing it?
  - Do you have control over your backups?
  - Are incremental copies made?
    - How many between full copies?
    - DB2 Merge copy run?
    - IMS Change Accums?
  - Are these copied to disk or tape? Stacked on tape?
  - Is everything in sync with the ICF catalog?
  - Do you verify recovery on a scheduled basis?
  - Are you taking copies of application spaces – test and production?



## Resource Readiness Reporter



- **RRR is an informative tool that will provide sites with the help they need in the following:**
  - Risk
    - Reduce risk of data loss by reporting missed backups
  - Exposure
    - Reduce exposure for application outage
  - Costs
    - Reveal the price of image copies – by examining their resource usage.
  
- **Analyzes all recovery resources for DB2 and IMS subsystems over a specified period of time.**
  - Note: Resource usage is valid for only DSNUTILB (DB2 image copies). RRR does not report on CPU/IO for vendor utilities. Same for IMS IC for now.

## How does it work ?

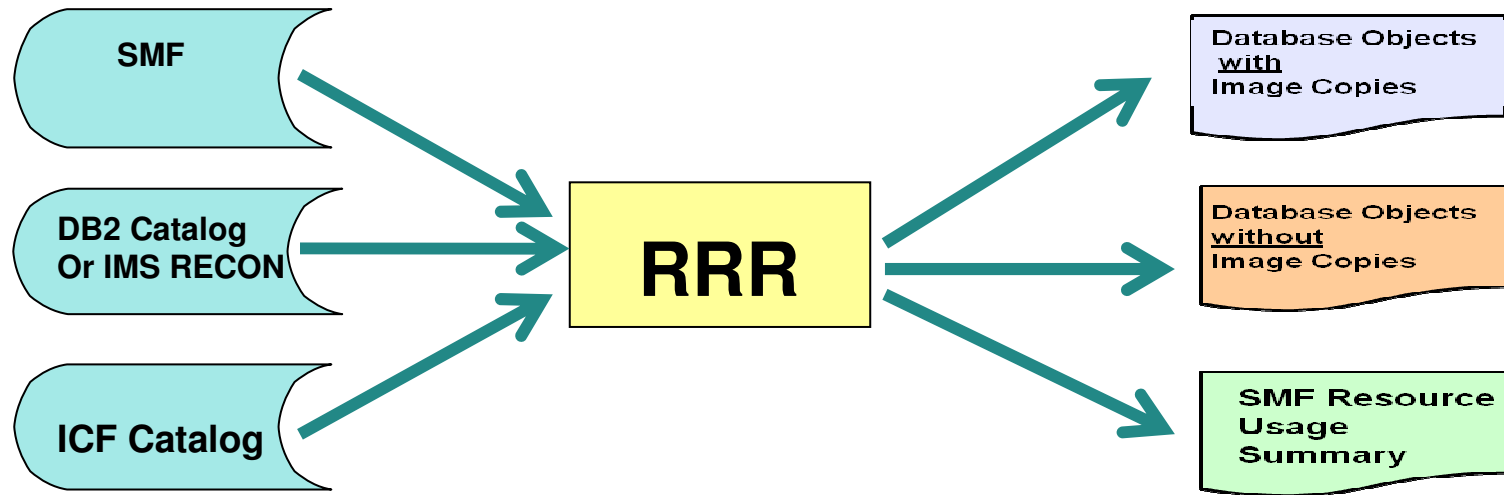

- **RRR will produce a report on**

- Which tsnames/dbnames do not have a valid image copies within a given time period.
- Which tsnames/dbnames have valid image copies within the same time period
  - And whether or not these “registered” image copies datasets still exist on the z/OS system
- The CPU and I/O resources required to create these image copies
- It shows IMS Change Accum consumption





## Sample Reports – IMS

### Recovery Readiness Image Copy Report

Start Timestamp 2011-09-11-00.00.00.000000

End Timestamp 2011-09-17-23.59.59.999999

### Objects without Image Copies

DBNAME	Area/Part	Type	DDNAME	Recov	IC Dataset	IC Dataset	Exists
DBFSAMD3	CUSDB	DEDB		Y			
DBFSAMD		FF	LOAN	Y			
DI21PART		FF	DI21PARO	Y			
DI21PART		FF	DI21PART	Y			

# Sample Report- SMF Report for IMS

```

Earliest SMF job found Day: 2011.232 Time: 00:01:01
Latest SMF job found Day: 2011.267 Time: 00:01:00

Image Copy Resources for RECON
Total IC Steps: .....239
CPU: .....26 (secs)
EXCP: .....195969
Tape Mounts: .....0
Elapsed Time: .....0:26:24

Change Accumulation Resources for System
Total CA Steps: .....1121
CPU: .....11220 (secs)
Elapsed Time: .....72:53:59

Total system Information
Total CPU : .....3680923 (secs)
Total Jobs: .....857171
Total IC Steps: .....17770
  Saturday : .....1018
  Sunday : .....2113
  Monday : .....3049
  Tuesday : .....2920
  Wednesday: .....2797
  Thursday : .....2330
  Friday : .....3543
ABTERM IC Steps: .....39
  
```

START-TIMESTAMP/  
END-TIMESTAMP INFO

Image Copy  
consumption of  
resources

Change Accum  
resource  
consumption  
summary

This information  
is for the LPAR –  
break down on  
how often ICs are  
done and which  
day



## Sample Reports – DB2

### Recovery Readiness Image Copy Report

Subsystem EA1A

Start Timestamp 2011-05-04-00.01.00.000000

End Timestamp 2011-05-04-23.59.00.999999

Objects without Image Copies



**Without ICs**

DBNAME	TSNAME	Part	Type	IC Dataset	IC Dataset Check
PARTDB01	PARTTS01	0001	TS		Not Checked
PARTDB01	PARTTS01	0002	TS		Not Checked
PARTDB01	PARTTS01	0003	TS	....	Not Checked

...

Objects with Image Copies



**With IC data sets checked**

DBNAME	TSNAME	Part	Type	IC Dataset	IC Dataset Check
PARTDB02	PARTTS02	0001	TS	PDBOB.DB02.TS02.P01.COPY	Checked
PARTDB02	PARTTS02	0002	TS	PDBOB.DB02.TS02.P02.COPY	Checked
PARTDB02	PARTTS02	0003	TS	PDBOB.DB02.TS02.P03.COPY	Checked

## Sample Report- SMF Report for DB2

### Recovery Readiness SMF Report

Subsystem EA1A

Start Timestamp 2011-05-04-00.01.00.000000

End Timestamp 2011-05-04-23.59.00.000000

### Resource Usage

#### Image Copy Resources for DB2 (or RECON)

Total IC Steps: .....545  
CPU: .....25014 (secs)  
EXCP: .....143856576  
Tape Mounts: .....1904  
Elapsed Time: .....41:07:21



## Installation

- **The RRR is a simple installable “Load and Go” program**
  - The files are 3 simple binary zipped files consisting of the DBRMLIB, LOADLIB and SAMPLIB and are found at:
    - [https://www14.software.ibm.com/webapp/iwm/web/reg/download.do?source=swg-ibmrrrdi&S\\_PKG=dl&lang=en\\_US&cp=UTF-8](https://www14.software.ibm.com/webapp/iwm/web/reg/download.do?source=swg-ibmrrrdi&S_PKG=dl&lang=en_US&cp=UTF-8)
  - The XMIT file will need to be unzipped and FTP'd to the mainframe where it will need to be RECEIVED. (Sample JCL to do the receive is provided in the installation instructions)
- **The file includes the following three data sets:**
  - #PERMHLQ.DB2IMS.LOADLIB – contains load modules that are used in the Recovery Readiness Reporter job.
  - #PERMHLQ.DB2IMS.SAMPLIB – contains the Recovery Readiness Reporter JCL members.
  - #PERMHLQ.DB2IMS.DBRMLIB – contains the Recovery Readiness Reporter DB2 DBRMLIB members.
- **The SAMPLIB contains a sample job RRRDB2 or RRRIMS that can be customized to run the RRR program.**



## Customize and run – one for db2 and one for ims

- **No binds necessary for the IMS – and RECON dsns are supplied through the JCL**
- **JCL found in SAMPLIB – RRRDB2 and RRRIMS**
- **Customize for the environment**
- **Job will create two reports**
  - First report lists the DB2 table and index spaces or IMS databases that have and have not been image copied within a given time period
  - Second report totals up the resources used to create image copies within a given time period



```
//RRRREP EXEC PGM=RRRMAIN
// ...
//REPORT DD SYSOUT=*
//SYSPRINT DD SYSOUT=*
//SMFDATA DD DSN=##SMFDATA,UNIT=SYSDA,DISP=(,DELETE,DELETE),
// DCB=(RECFM=VBS,LRECL=32760,BLKSIZE=0),SPACE=(CYL,(200,200))
//SMFIN DD DISP=SHR,DSN=#SMFIN
//RRROUT DD SYSOUT=*
//RRRIN DD *
DB2-REPORT Y
SSID #SSID
START-TIMESTAMP #STARTTS
END-TIMESTAMP #ENDTS
PLAN #RRRPLAN
```

## Agenda

- **Introduction**
- **IMS resources for recovery – WHAT ?**
- **Timestamp Recovery or Point in Time Recovery – WHEN ?**
- **Recovering IMS DB on local site – HOW ?**
- **IMS/DB2 solutions**
- **Disaster Recovery**

## Timestamp Recovery TR needs a Recovery Point RP

- **A RP is a period of time when the database is not allocated**
  - Means that the ALLOC record in RECON has been updated with a DEALLOC time
  - Created by taking the database offline with /DBR, UPDATE DB STOP(ACCESS), /DBD, UPDATE DB STOP(UPDATES)
  - The DB QUIESCE function ( V11+ ) provides the ability to create a RP without taking the database dataset offline
- **Recover database updates to an earlier state (time) than the last log record**
  - Uses: Earlier image copy + some logs data sets
- **In Datasharing Multiple updaters**
  - Multiple logs : Change Accumulation needed ( Unless DRF )
  - Multiple ALLOC records
  - Recovery point must be created on each IMS
  - Requires longer data outage
  - /DBR or Quiesce database on all systems before /START on any system
    - All ALLOC records must be closed at the same time
- **Recovery point (RP) Constraints**
  - No subsystem has the database open for update at recovery time

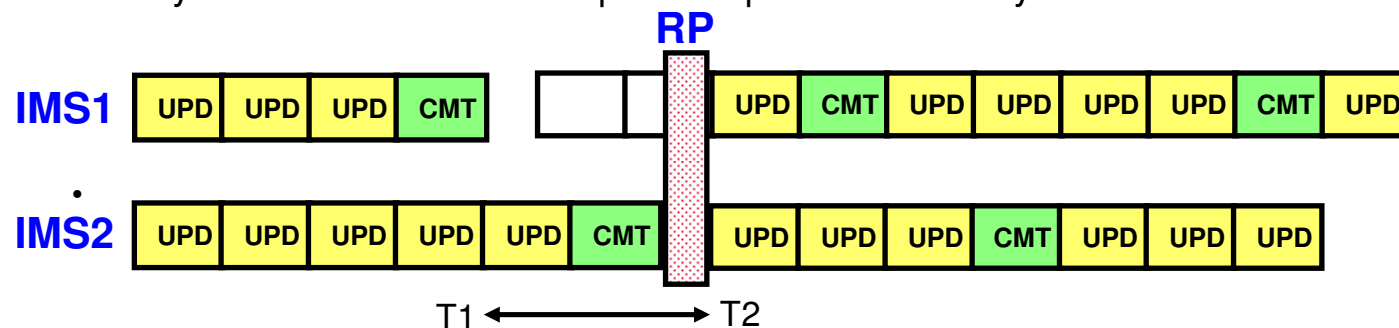



## Point In Time Recovery PITR to ANY timestamp

- Recover all committed updates to any timestamp other than a RP ( in the middle of an UOW )
- No need to have a RP written in the Recon.
- Not a DBRC supported Recovery Point when using IMS standard Database Recovery utility
- With Database Recovery Facility (DRF) Tool
  - Capability to recover IMS DBs to any timestamp, even if in the middle of UOW
  - Only committed updates applied



## Full Database recovery or Recover to current



- Full Database Recovery
  - Recover all database updates to last available log record
  - Uses: Last image copy + logs + backout as needed
  - Applies to Disaster Recovery when ICs and logs are on the remote site

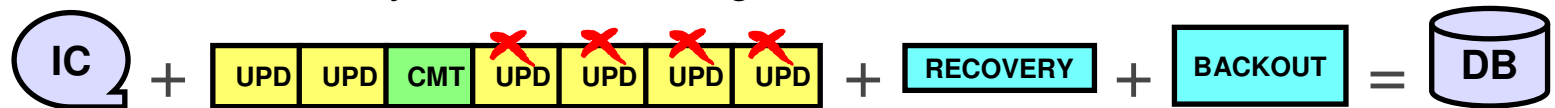

- Full Database Recovery with data sharing
  - Multiple concurrent logs
  - Merge updates on logs using Change Accumulation (CA)
    - No CA and backout needed if using DRF Tool
  - Uses: Last image copy + change accumulation + 2 backouts

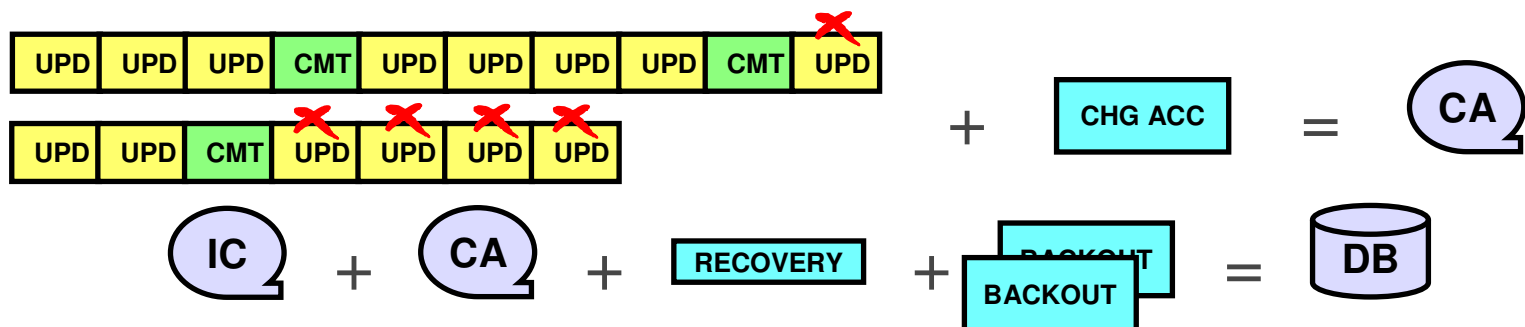

## Recovery Point vs Timestamp. Constraints

- **Depends on the amount of data you accept to loose**
- **IMS DB Quiesce must wait for all transactions to reach commit points with a timeout period of time**
  - IMS DB QUIESCE can be used with the HOLD option to pause the transaction activity at commit points, to create a clean IC.
  - If IMS DB QUIESCE used with NOHOLD, OLDS are switched and archived as part of the command. If datasharing, GENJCL.CA can be used to create CA datasets at this time. So the CA datasets have changes of them UNTIL the RP was created.
- **RP cannot be identified easily on more than one DB without tools**
  - Recovery solution Pack, DRF/XF component, RPID function
  - IMS Recovery Expert through ISPF panels.
    - Inspects the RECON data sets to locate clean recovery points for one or more databases
    - Can use these points as input to performing timestamp recoveries or incremental image copies
    - Also identify times when a database is allocated but not being updated. Can use these points as input to performing a point-in-time recovery

```
-- Recovery Time Spans Common to All Entries in the DBLIST:
10.112 14:09:26.387545-0700 to 10.112 14:09:54.142958-0700
10.112 14:11:22.407971-0700 to 10.112 14:11:40.840437-0700
```

## Agenda

- **Introduction**
- **IMS resources for recovery – WHAT ?**
- **Timestamp Recovery or Point in Time Recovery – WHEN ?**
- **Recovering IMS DB on local site – HOW ?**
- **IMS/DB2 solutions**
- **Disaster Recovery**

## How to recover on local site

- **Using IMS standard utilities**
  - Use GENJCL DBRC command to generate the correct JLC
    - GENJCL.RECOVER to generate a recover JCL
  - Utilitaires pour les indexes
  
- **Prepare and test jobs before needing them**
  
- **Take time to educate yourself and test different possibilities**
  
- **IMS/DB2: Organise cross team procedures to find the good RBA in DB2**
  - Recovery Expert can help you
  
- **Using IMS Tools**
  - To simplify recovery procedures
  - To simplify recovery JCLs
  - To speed up execution
  
- **Which tools ?**
  - IMS Recovery Solution Pack including DRF to do PITR, to speed up IC processing and build index
  - IMS Recovery Expert to facilitate, automate and create easy recovery procedures, and to « power » the use of Storage based fast replication solutions.
  - DB2 Recovery Expert with IMS RE to coordinate recovery between DB2 and IMS
  
- **Tools benefits: Availability increased, simplification, productivity**

## 4 solutions to recover

- **IMS Database Recovery utility (DFSURDB0)**
  - Special IMS Batch Region
  - Recovers a single DBDS per execution
  - No HSAM or GSAM support
  - DBRC GENJCL.RECOV support
  
- **IMS HP Image Copy Tool – Recovery Function**
  - Replace the IMS Database Recovery utility (DFSURDB0)
  - Recovers a single DBDS per execution
  - Accepts compressed (or normal) image copy
    - Needed to recover a DBDS from a compressed IC created by HPIC
  - DBRC GENJCL.RECOV support
  - 2 Operating Modes
    - Native mode
      - *Dynamic Allocation for input and output datasets*
    - IMS Compatible Mode

## 4 solutions to recover ...

- **IMS Recover Solution Pack with Database Recovery Facility component**

- High Performance IMS Database Recovery Solution

- Parallel Input/Output
- Parallel Processing / Sorting
- Single archived Log and CA Data Set Pass
- Single pass DB write
- DBRC Controlled

- Recovery of Multiple DBDS or Areas in one step

- Runs in Parallel with IMS Transaction Processing

- Recovery Time Options

- Recover to End of Logs
- Time Stamp Recovery (Recovery Point)
- Point-In-Time Recovery (Arbitrary Point)

*"Image Copy Needed" state is set in RECON for recovered databases after PITR*

*List of Open UOW*

- **Can be driven by IMS Recovery Expert to do PITR and use System Level Backup data.**
- **Drives High Performance Image Copy, IMS Index Builder or High Performance Pointer Checker in the same JCL.**
- **Can be used for Recovery on Local Site or Disaster Recovery.**

## More on IMS Database Recovery Facility

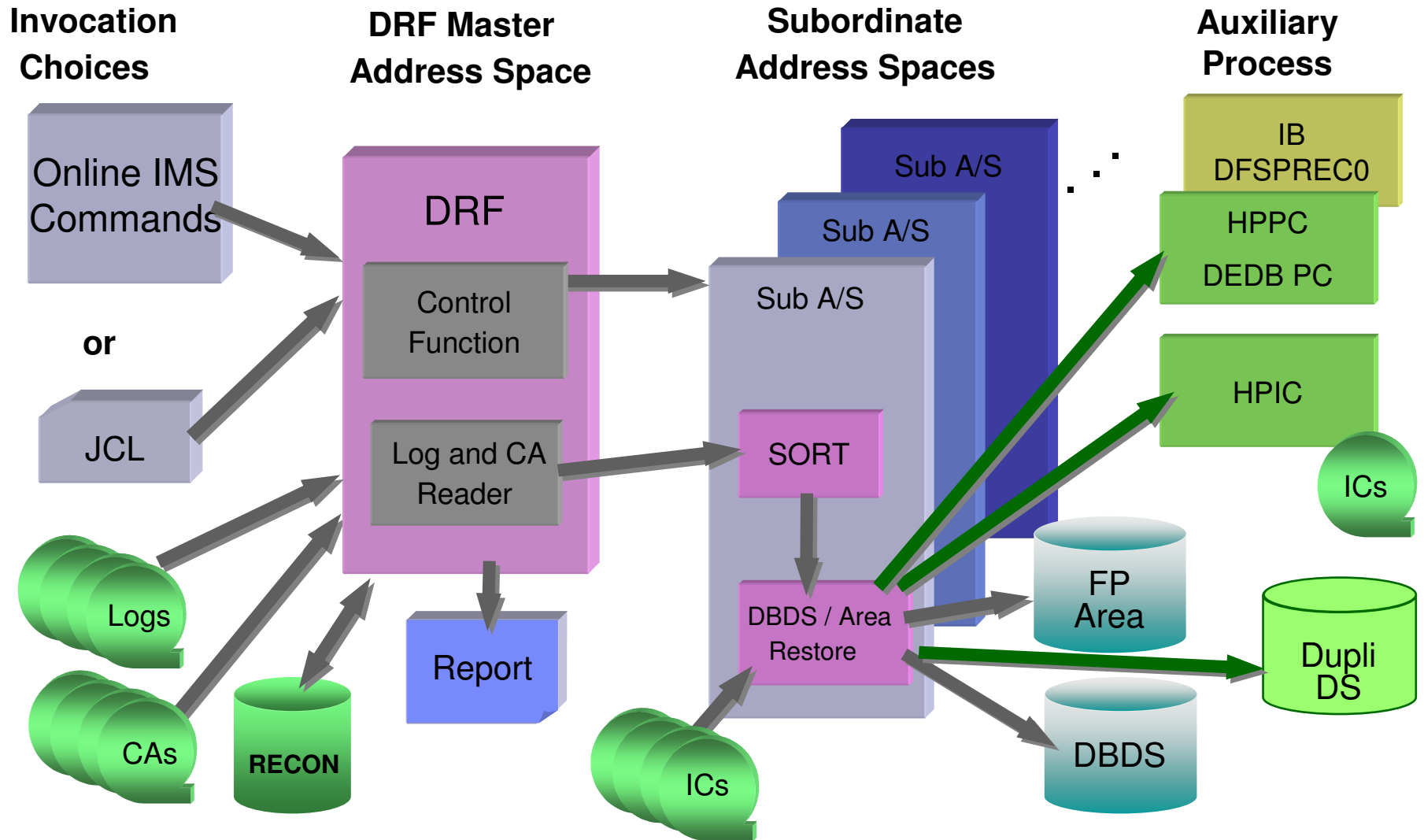



## 4 solutions to recover ... IMS Recovery Expert / DB2 Recovery Expert

- **Reduce**
  - backup, recovery, and administration costs
  - skills to do it
  - host CPU and I/O resource utilization
- **Perform backups instantly**
- **Fast restore and parallel recovery reduces recovery time**
- **Simplify disaster recovery operations and procedures**
- **DBMS and storage-based fast-replication integration**
- **Provide a sophisticated infrastructure and metadata to manage the DBMS and storage processor coordination**
  
- **Used for both DR and Local Application Recovery**
- **Used for IMS and DB2**

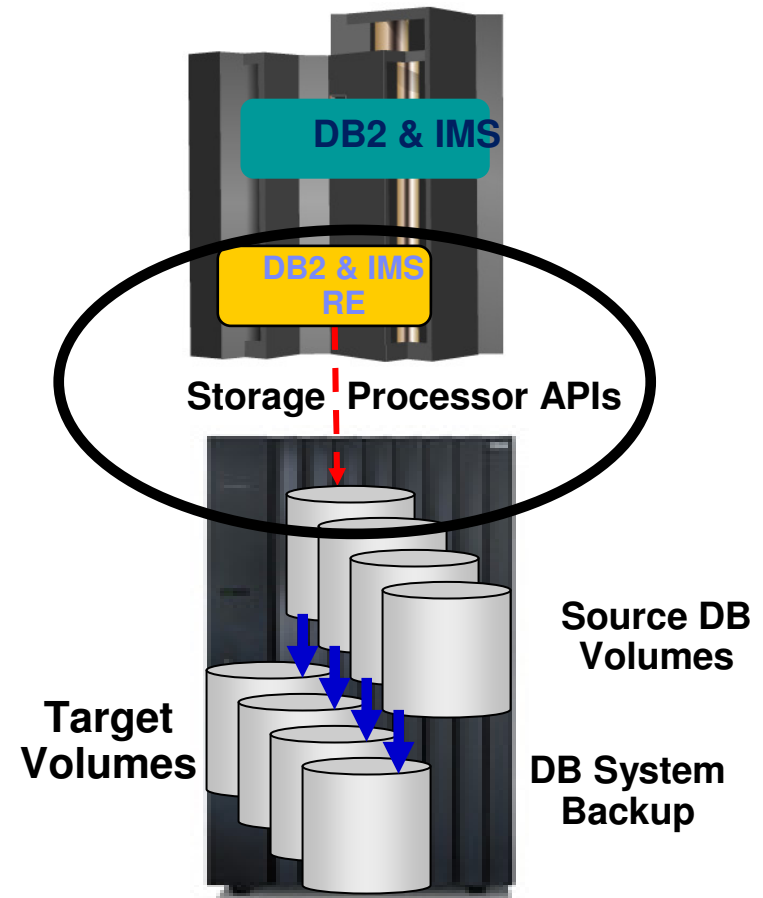



## Intelligent Recovery Manager (IRM) ( part of Recovery Expert )

- **Single interface for recovery processes, ISPF or GUI**
- **Recovers application, individual database, or indexes**
  - Even if the SLB contains other databases than the ones we want to recover
  - Using Current, Timestamp, or PITR
- **Application profile is created in advance**
  - Single database or group of databases
  - Logically related databases and indexes can be included automatically
- **Determines best recovery method**
  - Restores from either IC or SLB
  - Indexes that can not be restored are rebuilt
  - Recovery using log apply needs one pass of the logs
  - Access to DBs is automatically stopped and restarted at end of recovery
  
  - Drives the IMS Recovery Solution Pack if needed
    - Runtime analysis determines utilities to run (and their order)
    - Spawns recovery jobs as needed
- **Storage-based fast-replication performs restore**
  - Performs an instantaneous data set restore process

## Positioning IMS Recovery Expert and IMS Recovery Solution Pack

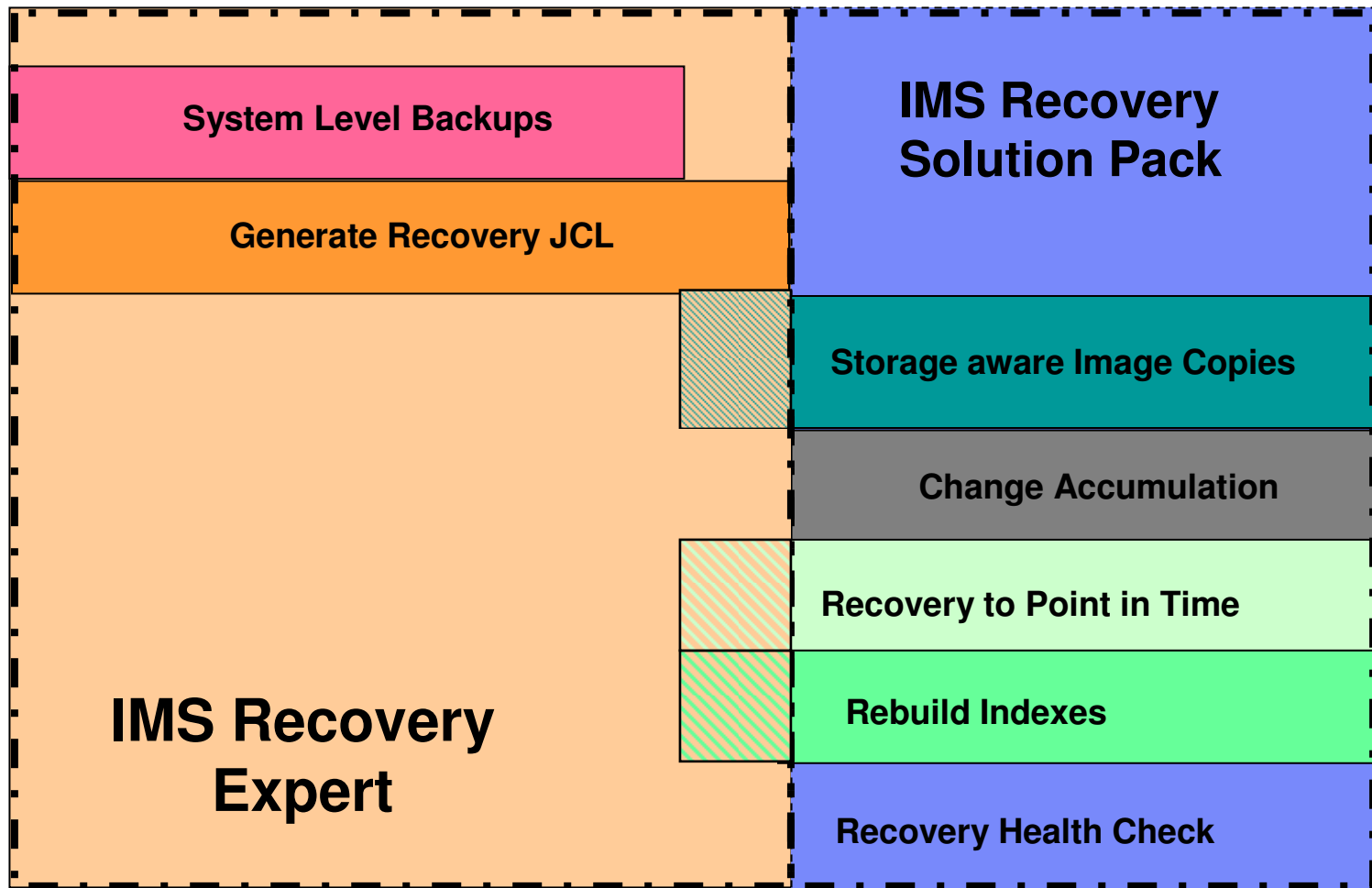

No need to have a big IMS background to recover with Tools !



---

## Agenda

- **Introduction**
  
- **IMS resources for recovery – WHAT ?**
  
- **Timestamp Recovery or Point in Time Recovery – WHEN ?**
  
- **Recovering IMS DB on local site – HOW ?**
  
- **IMS/DB2 solutions**
  
- **Disaster Recovery**

## IMS / DB2 Coordinated Timestamp Recovery

- **Must recover IMS and DB2 to same consistent time**
- **Must establish concurrent recovery points**
  - Use an IMS Quiesce and DB2 Quiesce point at the same time
- **IMS and DB2 produce independent log streams**
  - Use IMS Recovery Expert and DB2 Recovery Expert Tool to find the good timestamp to have both data in a consistent state :
    - DB2 RE will take the IMS timestamp and convert it to a RBA (LRSN for datasharing) to be used by DB2 recover and PITR..
  - IMS Recovery Expert and DB2 Recovery Expert can create SLB using Flash Copy at the same time in a couple of seconds and can find a coordinated timestamp in it.

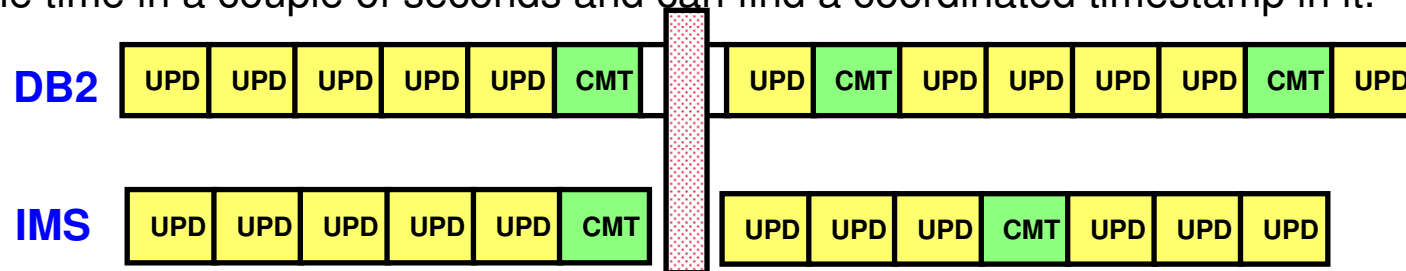



---

## IMS/DB2 solutions

- **IMS Basic + DB2 Basic to create a Quiesce point**
- **IMS Basic RP + look for a good RBA manually in DB2**
- **Full recovery**
  
- **IMS PITR with manual identification of RBA/LRSN for DB2**
  
- **Recovery Expert IMS/DB2 solution with combined SLB or separate SLB**
  
- **IMS Recovery Expert and Recovery Solution Pack ( DRF ) for PITR + DB2 Recovery Expert to have RBA/LRSN identified automatically.**

---

## Agenda

- **Introduction**
- **IMS resources for recovery – WHAT ?**
- **Timestamp Recovery or Point in Time Recovery – WHEN ?**
- **Recovering IMS DB on local site – HOW ?**
- **IMS/DB2 solutions**
- **Disaster Recovery**



## IMS and DB2 Disaster Recovery Tutorials

- **IBM developerWorks**

- [www.ibm.com/developerworks](http://www.ibm.com/developerworks)
  - External IBM website with articles, tutorials and demonstrations

- **IMS Disaster Recovery Tutorials**

- Four parts:
  - Part 1: Overview of all solutions
  - Part 2: IMS Base and IMS Tool solutions
  - Part 3: IMS Recovery Expert Disaster and Local Recovery
  - Part 4: Coordinated IMS and DB2 Disaster Recovery
- Downloadable demonstration file
  - Demos are installed on hard disk and viewed with internet browser

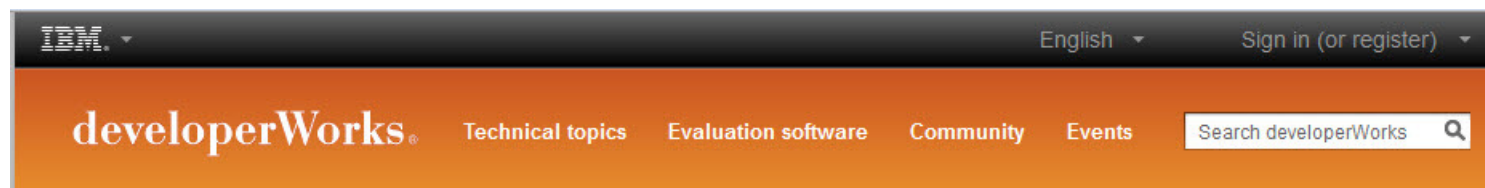

# DeveloperWorks URL for Tutorials

- [http://www.ibm.com/developerworks/views/data/libraryview.jsp?search\\_by=IMS+disaster+recovery+solutions](http://www.ibm.com/developerworks/views/data/libraryview.jsp?search_by=IMS+disaster+recovery+solutions)

Title	Type	Date
<p><a href="#">Exploring IMS disaster recovery solutions, Part 1: Overview</a></p> <p>Every customer needs a Disaster Recovery (DR) plan. The strategies used differ from one customer to another and they differ in time to recovery and loss of data. For IMS, there are five types of disaster recovery solutions: restart, recovery, recovery and restart, coordinated IMS and DB2 restart, and coordinated IMS and DB2 disaster recovery and restart. While the Storage Mirroring recovery solutions are classified as restart solutions, we will focus only on the non-Storage Mirroring <b>IMS disaster recovery solutions</b> in this series.</p>	Articles	29 Mar 2012
<p><a href="#">Exploring IMS disaster recovery solutions, Part 2: IMS Base and IMS Tools recovery solutions</a></p> <p>Every customer needs a Disaster Recovery (DR) plan. The strategies used differ from one customer to another and they differ in time to recovery and loss of data. For IMS, there are five types of DR solutions: restart, recovery, recovery and restart, coordinated IMS and DB2 restart, and coordinated IMS and DB2 disaster recovery and restart. Here in Part 2, we explore the recovery solutions that use only the IMS base functions and some of the functions in the IMS Tools.</p>	Tutorial	12 Apr 2012
<p><a href="#">Exploring IMS disaster recovery solutions, Part 4: Coordinated IMS and DB2 solutions</a></p> <p>Every customer needs a disaster recovery (DR) plan. The strategy will differ from one customer to the next. For IMS, there are two types of DR solutions: 1) IMS specific, and 2) Storage Mirroring. In this tutorial, we explore the IMS specific DR solutions. There are solutions that use only the IMS base product and solutions that use the IBM IMS Tools products. For each DR solution, there will be a discussion of the key concepts related to that solution.</p>	Tutorial	03 May 2012
<p><a href="#">Exploring IMS disaster recovery solutions, Part 3: IMS Recovery Expert solutions</a></p> <p>Every customer needs a Disaster Recovery (DR) plan. The strategies used differ from one customer to another and they differ in time to recovery and loss of data. For IMS, there are five types of DR solutions: restart, recovery, recovery and restart, coordinated IMS and DB2 restart, and coordinated IMS and DB2 disaster recovery and restart. Here in Part 3, we explore both the recovery and recovery and restart solutions provided by the IMS Recovery Expert product.</p>	Tutorial	19 Apr 2012

1 - 4 of 4 results

[Show Summaries](#) | [Hide Summaries](#)

 [Subscribe to search results \(RSS\)](#)

