



# IBM COLLABORATION SUMMIT

Barcelona, 3 de octubre  
Madrid, 10 de octubre



# Elementos de Infraestructura

Fernando Rodríguez Cobo

IT Specialist

# Estrategia de colaboración de IBM Lotus

Cliente rico



Windows/Office



Navegador



eForms



Portal



RSS/Atom



Disp. Móviles



## Servicios de interacción y de cliente (online u off-line)

**Lotus Domino**

Correo, calendario y aplicaciones de colaboración.

**Lotus Sametime**

Comunicaciones unificadas y servicios de colaboración en tiempo real

**Lotus Quickr**

Servicios de contenidos colaborativos y trabajo en equipo

**Lotus Connections**

Software Social para la empresa

**WebSphere Portal**

Servicios de aplicaciones compuestas e integración

## Framework de aplicaciones compuestas



Procesos de negocio

Información



# Soluciones de colaboración multiplataforma

## Lotus Domino

Correo, calendario y aplicaciones de colaboración.

## Lotus Sametime

Comunicaciones unificadas y servicios de colaboración en tiempo real

## Lotus Quickr

Servicios de contenidos colaborativos y trabajo en equipo

## Lotus Connections

Software Social para la empresa

## WebSphere Portal

Servicios de aplicaciones compuestas e integración



Wintel



Blades



Unix



System i



Mainframes



# Soluciones de colaboración multiplataforma

## Lotus Domino

Correo, calendario y aplicaciones de colaboración.

## Lotus Sametime

Comunicaciones unificadas y servicios de colaboración en tiempo real

## Lotus Quickr

Servicios de contenidos colaborativos y trabajo en equipo

## Lotus Connections

Software Social para la empresa

## WebSphere Portal

Servicios de aplicaciones compuestas e integración



## The IBM Systems Family



System x™



BladeCenter®



System p™



System i™



System z™



# The IBM Systems family

Innovative, proven technology providing platform choice to match unique business needs



## System z™

The flagship for IBM Systems innovation and the heart of a highly secure, resilient and integrated infrastructure.



## BladeCenter®

Simplify data center complexity.



## System i™

*Install faster, Maintain easier.*

System i solutions provide reliable and secure ways to simplify your IT so you can invest the savings in business innovation

# IBM Systems



## System Storage™

Connected. Protected.

Complete.



## System x™

Innovation comes standard.



## System p™

Get the power to do more, spend less.



# Aproximación a soluciones de infraestructura

## Escalabilidad Vertical y Horizontal

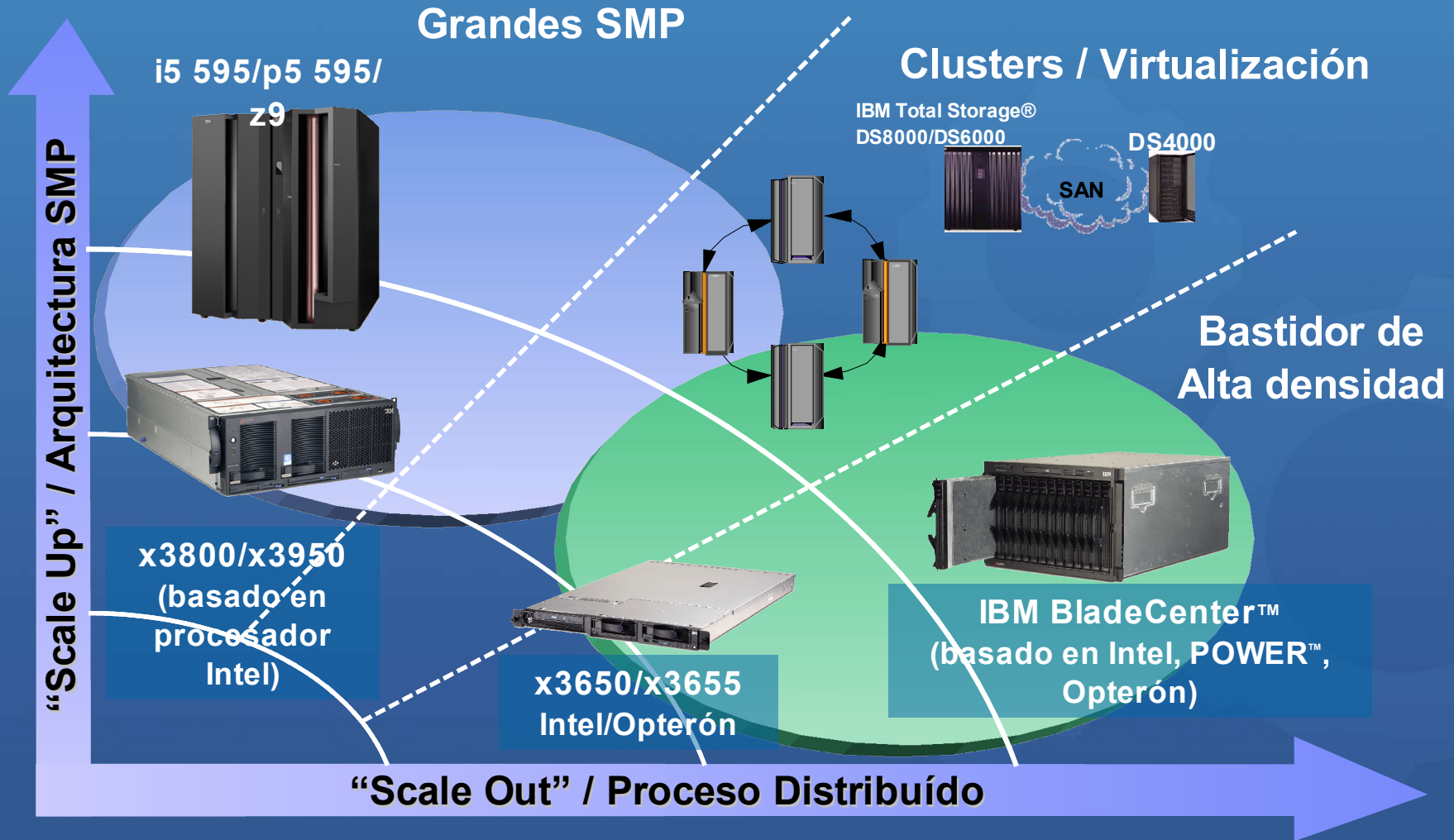

# System z9 (EC & BC): unique functions and features

## Five New Hardware Models

Faster Uni Processor

Up to 54 CPs

Up to 512 GB Memory

Up to 60 LPARs

CBU for IFL, ICF and zAAP

Separate PU Pool Management

Redundant I/O Interconnect

Enhanced Driver Maintenance

Enhanced Book Availability

Dynamic Oscillator Switchover

Preview\*  
Server Time Protocol



Faster 2.7 GB STI and more of them

MIDAW facility

Multiple Subchannel Sets per LCSS

63.75K Subchannels for Set-0

Up to 336 FICON® Express2 Channels

N\_Port ID Virtualization

IPv6 Support for HiperSockets™

OSA-Express2 1000BASE-T

OSA-Express2 OSN (OSA for NCP)

Enhanced CPACF with AES, PRNG and SHA-256

Configurable Crypto Express2





# System z9 - Logical Partitions and Virtual Servers

*flexible and cost effective for server consolidation, integration and on demand*

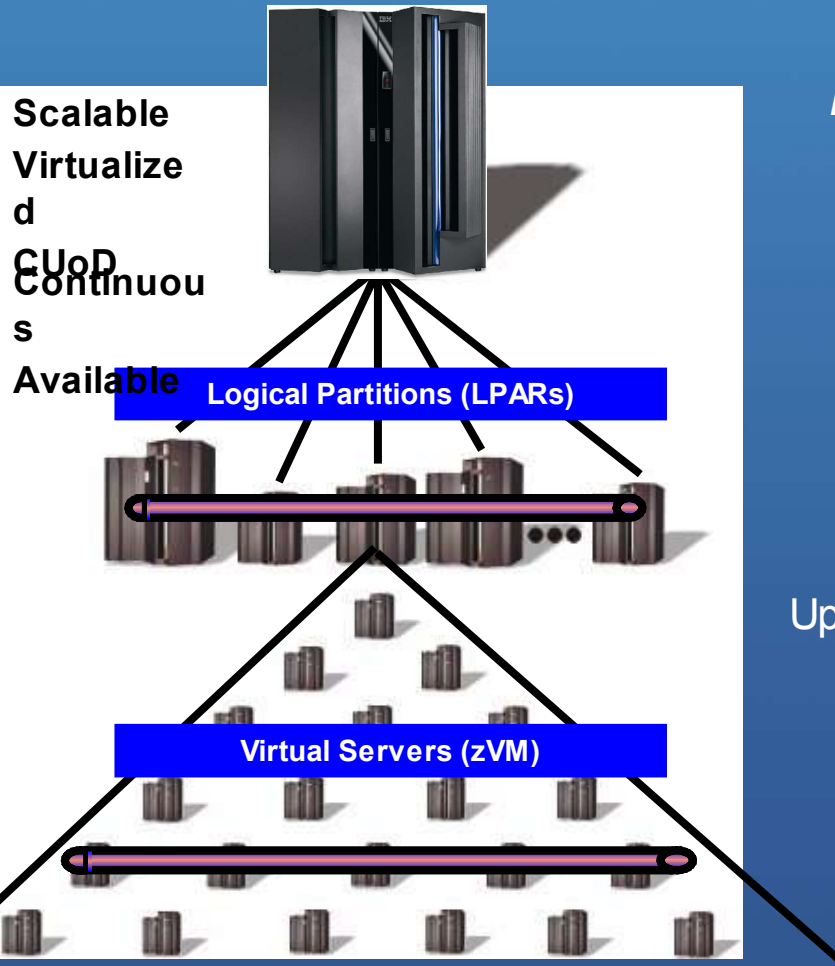

**Logical Partitioning (PR/SM)** - up to 60 partitions  
*Multiple applications (100's) per logical partition*

**z/VM Virtualization** – processors, memory and I/O  
 Self-Managed Workload Management (Autonomic)  
 across partitions (Intelligent Resource Director)  
 Virtual I/O and Shared I/O

*Hundreds to Thousands of Virtual Servers*

Integration - **HiperSockets** (Virtual LAN)

Up to 32 System Images in a Cluster (**Parallel Sysplex**)

**First partitioning implementation in the 1967 time frame**  
**LPAR delivered in 1987**  
**Virtual Servers first implemented in 1967**



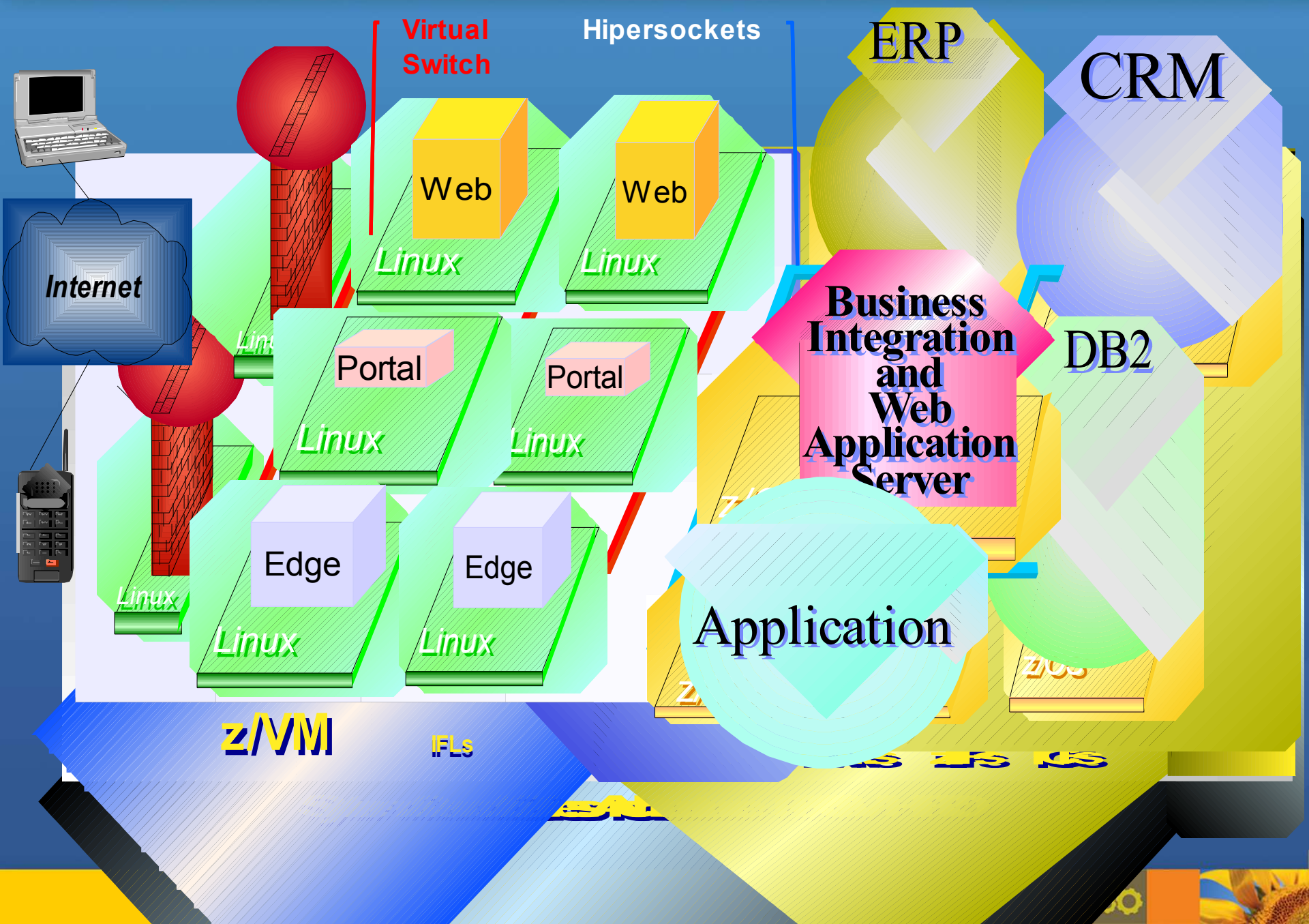

# IBM System p: p5 systems highlights

■	IBM POWER5™ processors	5 <sup>th</sup> generation POWER™ technology Simultaneous multi-threading Advanced POWER Virtualization* and autonomic features
■	IBM System p systems	IBM System p p5 510, 520, 550, 570, 575, 590 and 595 IBM System p p5 510, 510, 550 and 570 Express
■	AIX 5L™ V5.3	Support for IBM Virtualization Engine™ systems technologies like Micro-Partitioning™ and virtual I/O
■	Linux®	Expanded offerings with new functionality
■	i5/OS™**	New OS support for p5 systems
■	HMC support / options	Support for IBM System p p5 systems New attachment capabilities
■	I/O options	7311-D11 remote I/O drawer 10 Gigabit Ethernet and 2 Gigabit Fibre Channel



# IBM System p p5 Servers

**p5-520**  
2-way  
1.65 GHz POWER5™



**p5-520 Express**  
Up to 2-way  
1.5 GHz POWER5

**p5-550**  
Up to 4-way  
1.65 GHz POWER5



**p5-550 Express**  
Up to 4-way  
1.5 GHz POWER5

**p5-570**  
Up to 16-way  
1.65 GHz POWER5  
1.9GHz POWER5



**p5-570 Express**  
Up to 8-way  
1.5 GHz POWER5

**p5-590**  
Up to 32-way



**p5-595**  
Up to 64-way



- 8-way to 32-way
- 1.65 GHz IBM POWER5
- Up to 1TB memory
- Advanced POWER™
- Virtualization [Standard]
- Up to 8 I/O drawers
- Capacity on Demand\*

- 16-way to 64-way
- 1.65 GHz POWER5
- 1.9 GHz POWER5
- Up to 2TB memory
- Advanced POWER
- Virtualization [Standard]
- Up to 12 I/O drawers
- Capacity on Demand\*



# IBM System p: advanced virtualization option

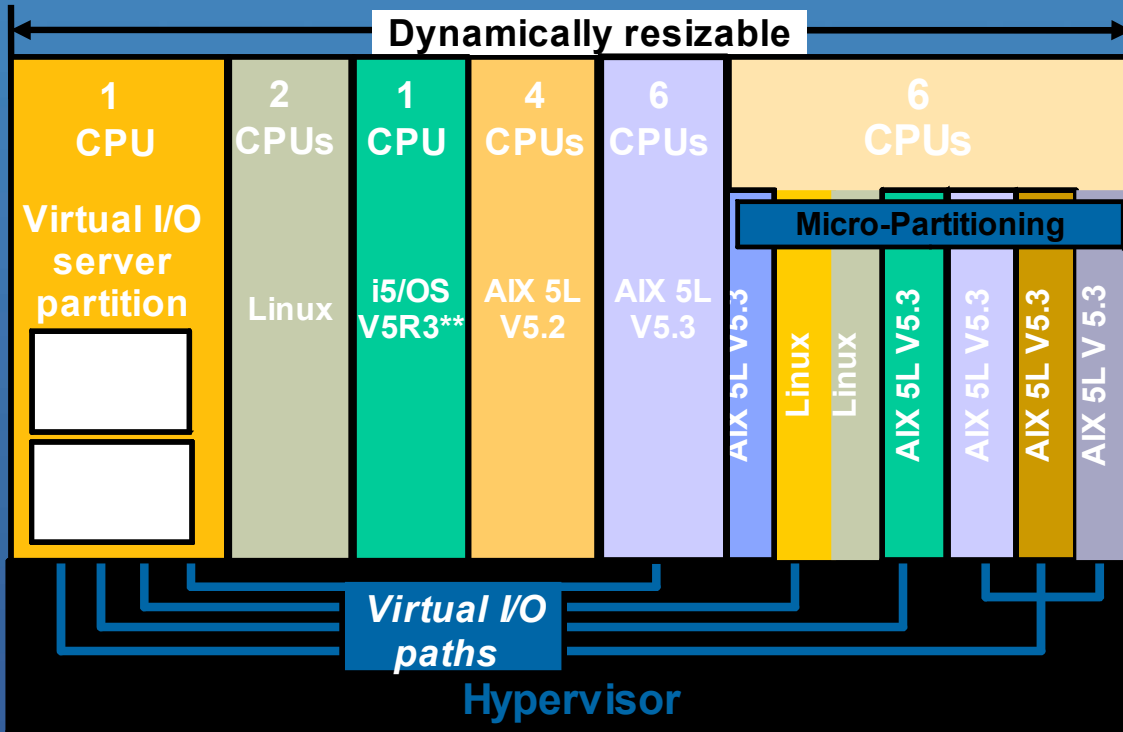

## Virtual I/O Server

- Shared Ethernet
- Shared SCSI and Fibre Channel-attached disk subsystems
- Supports AIX 5L V5.3 and Linux\* partitions

## Micro-Partitioning

- Share processors across multiple partitions
- Minimum partition 1/10<sup>th</sup> processor
- AIX 5L V5.3, Linux\*, or i5/OS\*\*

## Partition Load Manager

- Both AIX 5L V5.2 and AIX 5L V5.3 supported
- Balances processor and memory request

## Managed via HMC

\* SLES 9 or RHEL AS 3

\*\* Available on 1.65 GHz p5-570, p5-590 and p5-595 models

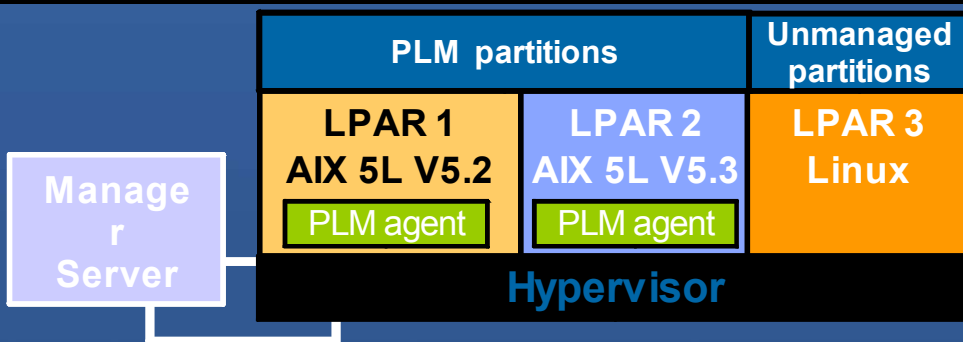

# IBM System p: Virtual I/O server disk sharing

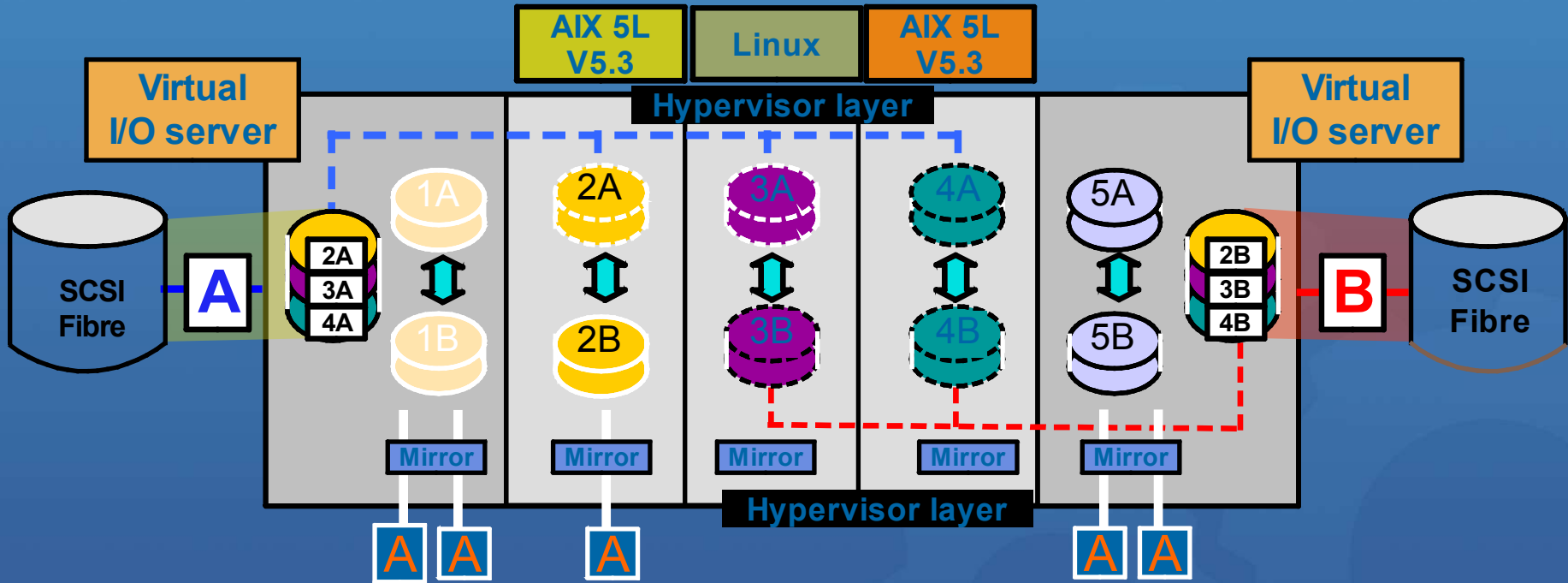

- One physical drive can appear to be multiple logical drives
  - LUNs appear as individual logical drives
- Minimizes the number of adapters
- Can have mixed configuration (virtual and real adapters)
- SCSI and Fibre supported
- Supports AIX 5L V5.3 and Linux partitions



# IBM System p: Virtual I/O server Ethernet sharing

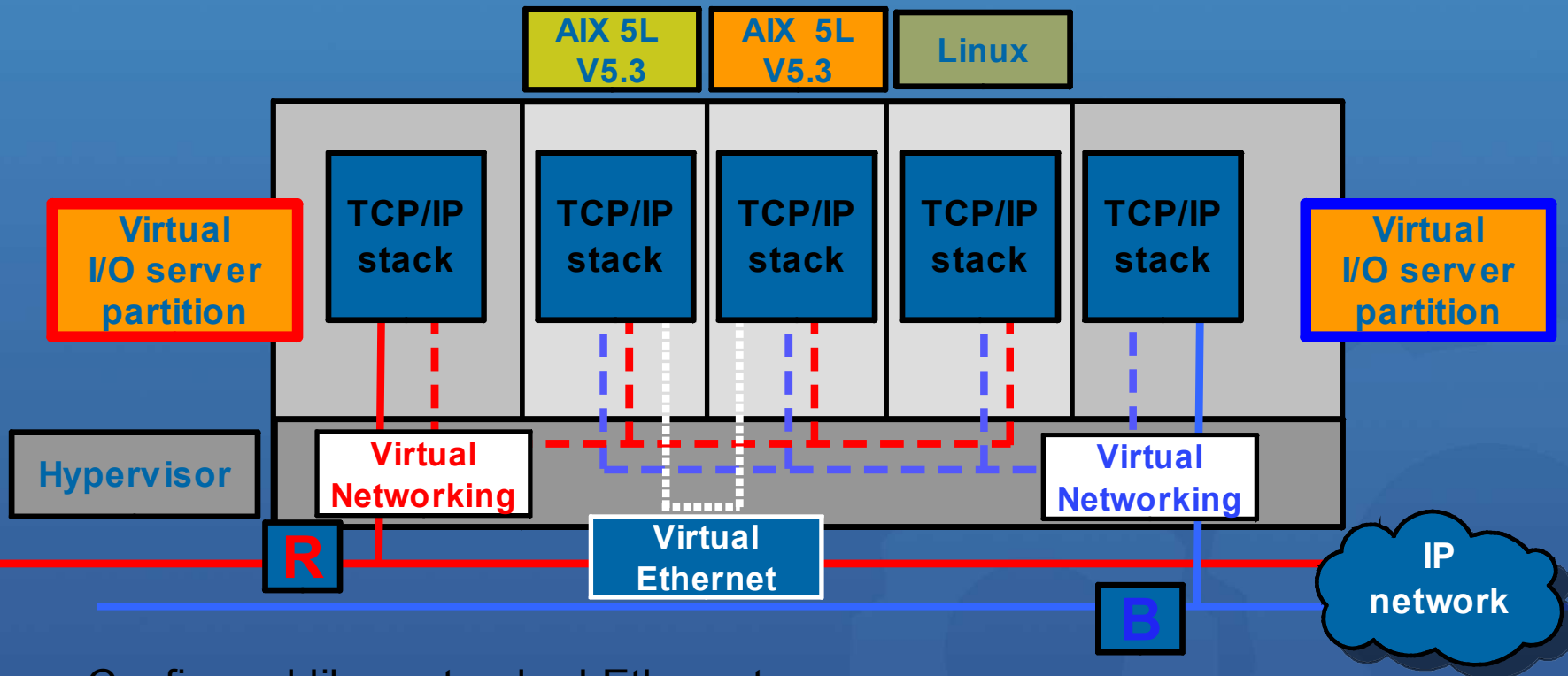

- Configured like a standard Ethernet
- IP forwarding / bridging provided by I/O server partition
- Can have multiple connections per partition
- Virtual “MAC” addressing
- Each adapter can support 16 virtual Ethernet LANs



# Transaction Performance - Single System TPC-C V5



System	Chip/Core/Thread	Avail.	\$/tpm C	Database	OS	tpm C	tpm C/Core
IBM p570 (4.7 GHz POWER6)	2/4/8	11/26/07	\$3.50	Oracle 10g	AIX 5L V5.3	404,462	101,115
IBM p570 (4.7 GHz POWER6)	8/16/32	11/21/07	\$3.54	IBM DB2 9	AIX 5L V5.3	1,616,162	101,010
IBM p5-570 (2.2 GHz POWER5+)	8/16/32	05/31/06	\$4.42	IBM DB2 v8.2	AIX 5L V5.3	1,025,169	64,073
IBM p5-595 (2.3 GHz POWER5+)	32/64/128	01/22/07	\$2.97	IBM DB2 9	AIX 5L V5.3	4,033,378	63,021
IBM p5-570 (1.9 GHz POWER5)	8-core	09/30/04	\$4.99	IBM DB2 v8.1	AIX 5L V5.3	429,899	53,737
IBM p5-570 (1.9 GHz POWER5)	4-core	10/17/05	\$3.93	Oracle 10g	AIX 5L V5.3	203,439	50,859
IBM p5-570 (1.9 GHz POWER5)	16-core	09/30/04	\$4.95	IBM DB2 v8.1	AIX 5L V5.3	809,144	50,571
HP rx4640 (1.6 GHz Itanium 2)	2/4/8	09/01/06	\$2.75	Oracle 10g	HP-UX 11.iv2	200,829	50,207
IBM p5-595 (1.9 GHz POWER5)	64-core	05/14/05	\$5.07	IBM DB2 v8.1	AIX 5L V5.3	3,210,540	50,164
IBM p5-595 (1.9 GHz POWER5)	32-core	04/20/05	\$5.05	Oracle 10g	AIX 5L V5.3	1,601,784	50,055
IBM p5-570 (1.9 GHz POWER5)	4-core	09/30/04	\$5.62	Oracle 10g	AIX 5L V5.3	194,391	48,597
IBM p5-570 (1.9 GHz POWER5)	8-core	09/30/04	\$5.26	Oracle 10g	AIX 5L V5.3	371,044	46,380
HP rx6600 (1.6 GHz Itanium 2)	4/8/16	12/16/06	\$1.99	Oracle 10g	Red Hat Linux	359,440	44,930
HP rx4640 (1.6 GHz Itanium 2)	4-core	12/17/04	\$3.94	Oracle 10g	Red Hat Linux	161,217	40,304
HP ProLiant DL585 (2.6 GHz Opteron)	4-core	05/06/05	\$2.80	SQL EE	Windows EE	130,623	32,655
HP Superdome (1.6 GHz Itanium 2)	64/128/256	08/23/07	\$2.93	Oracle 10g	HP-UX 11iv3	4,092,799	31,974
HP ProLiant DL585 (2.4 GHz Opteron)	8-core	12/05/05	\$2.02	IBM DB2 v8.2	Windows EE	236,054	29,506
HP ProLiant DL585 (2.2 GHz Opteron)	8-core	05/31/05	\$2.04	SQL EE	Windows EE	187,296	23,412
HP Superdome (1.6 GHz Itanium 2)	64-core	06/05/06	\$4.82	SQL EE	Windows DE	1,231,433	19,241
HP rx5670 (1.5 GHz Itanium 2)	16-core	04/15/04	\$4.56	SQL DE	Windows EE	301,225	18,826
HP Superdome (1.5 GHz Itanium 2)	64-core	04/14/04	\$8.33	Oracle 10g	HP-UX 11.i	1,008,144	15,752
Fujitsu PP2500 (SPARC64 1.3 GHz)	64-core	04/30/04	\$12.43	Oracle 10g	Solaris 8	595,702	9,307
Sun Fire	No Published Results						?





# SAP SD 2-Tier (Rankings by Users/Core)



Configuration	Software Releases	Certification #	Processor / Cores / Threads	Number of Benchmark Users	Users/Core
IBM System p 570 (4.7 GHz POWER6) 128 GB Memory	SAP ECC Release 6.0 AIX 5L V5.3, DB29	2007039	8/16/32	8000 @ 1.98 sec	500
IBM System p5 595 (2.3 GHz POWER5+) 512 Memory	SAP ECC 5.0 AIX 5L V5.3, DB2 UDB v9.1	2006045	64/64/128	23,456 @ 1.98 sec	366
IBM eServer p5 570 (1.9 GHz POWER5) 32GB Memory	SAP R/S 4.70 AIX 5L V5.3, DB2 UDB v8.1	2004042	4	1,313 @ 1.97 sec	328
IBM eServer p5 570 (1.9 GHz POWER5) 64GB Memory	SAP R/S 4.70 AIX 5L V5.3, DB2 UDB v8.1	2004041	8	2,600 @ 1.99 sec	325
IBM eServer p5 570 (1.9 GHz POWER5) 128GB Memory	SAP R/S 4.70 AIX 5L V5.3, DB2 UDB v8.1	2004040	16	5,056 @ 1.99 sec	316
IBM eServer p5 595 (1.9 GHz POWER5) 512GB Memory	SAP R/S 4.70 AIX 5L V5.3, DB2 UDB v8.2	2004062	64	20,000 @ 1.98 sec	312
HP rx6600 (1.6 GHz Itanium 2) 48GB Memory	SAP Version 6.0 HP-UX 11, Oracle 10g	2006083	4/8/16	2,150 @ 1.97 sec	268
HP DL585 (2.6 GHz Opteron 852) 16GB Memory	SAP R/3 4.70 Windows 2003, SQL Server	2005008	4	1,017 @ 1.98 sec	254
HP Superdome (1.6 GHz Itanium 2) 512GB Memory	SAP Version 6.0 HP-UX 11, Oracle 10g	2006089	64/128/256	30,000 @ 1.80 sec	234
HP DL585 (2.2 GHz Dual Core Opteron 852) 32GB Memory	SAP R/3 4.70 Windows 2003, SQL Server	2005017	8	1,772 @ 1.96 sec	221
HP rx4640 (1.5 GHz Itanium 2) 32GB Memory	SAP R/3 4.70 HP-UX 11, Oracle 9i	2004030	4	880 @ 1.89 sec	220
Sun V40z (2.4 GHz Opteron 850) 32GB Memory	SAP R/3 4.70 SUSE LINUX, Oracle 9i	2004044	4	820 @ 1.95 sec	205
HP rx8620 (1.5 GHz Itanium 2) 64GB Memory	SAP R/3 4.70 HP-UX 11, Oracle 9i	2003062	16	2,880 @ 1.95 sec	180
HP rp4440-8 (1.0 GHz PA-8900) 32GB Memory	SAP R/3 4.70 HP-UX 11, Oracle 9i	2005022	8	1,360 @ 1.98 sec	170
Fujitsu PrimePower (2.08 GHz SPARC64 V) 512GB Memory	SAP R/3 4.70 Solaris 9, Oracle 9i	2005013	128	21,000 @ 1.91 sec	164
Sun Fire V490 (1.5 GHz UltraSPARC IV+) 32 GB Memory	mySAP ERP 2004 Solaris 10, MaxDB 7.5	2005042	8	1050 @ 1.87 sec	131
Sun Fire T2000 (1.2 GHz UltraSPARC T1) 32GB Memory	SAP ECC 5.0 Solaris 10, MaxDB 7.5	2005047	8	950 @ 1.91 sec	118
Sun E25K (1.2 GHz US IV) 576GB Memory	SAP R/3 4.70 Solaris 9, Oracle 9i	2004039	144	10,175 @ 1.95 sec	71



# Capacity on Demand for IBM System p systems

## Capacity Upgrade on Demand

- Upgrade system with processors and/or memory
- No special contracts, no required monitoring (no ability to turn off the capacity)
- Purchase agreement

## On/Off Capacity on Demand

- Temporary use of requested number of processors or amount of memory
- Client selects the capacity and activates the resource (registered system)
- Capacity can be turned on and off by the client
- Information captured by IBM (or reported to IBM)
- Rental agreement

## Reserve Capacity on Demand

- Processor resources only (processor days)
- Capacity can be turned on and off by the client
- Prepaid debit agreement
- Requires AIX 5L V5.3 and APV

## Trial Capacity on Demand

- Allow clients to test the effects of additional processors and/or memory
- Partial or total activation of processors and memory
- Resources available for fixed time
- No formal commitment required



# IBM System i: Entorno operativo “on demand”

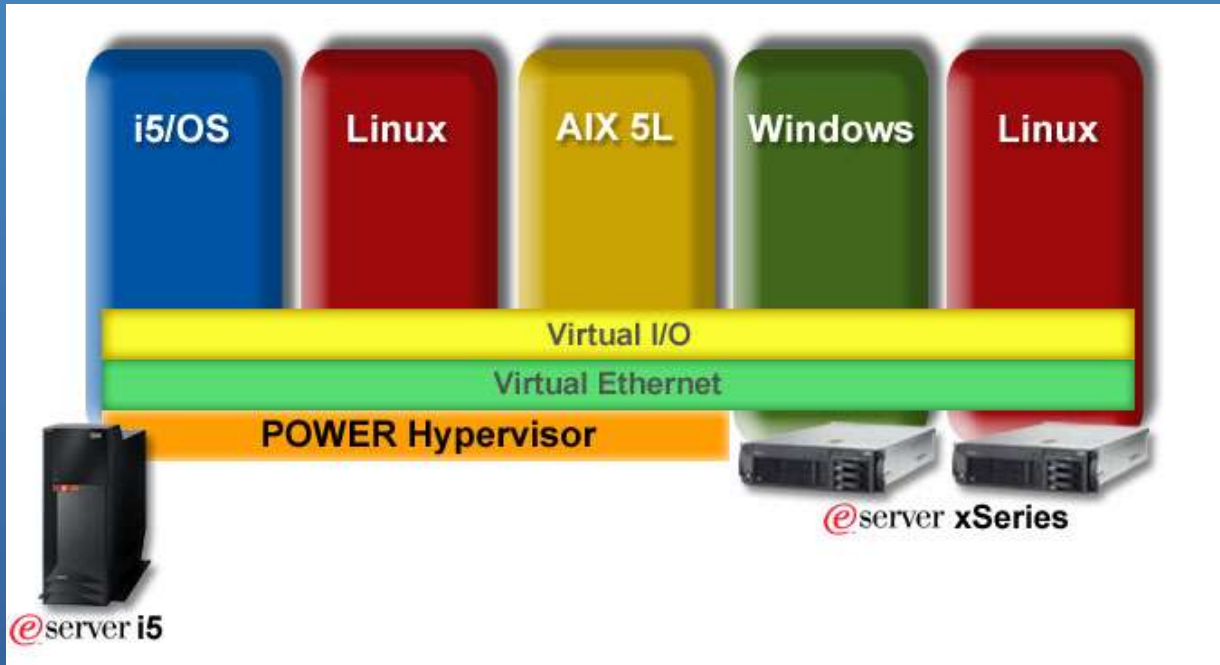

- El POWER Hypervisor™ soporta i5/OS, AIX 5L, Linux
- Mejora los ratios de utilización del servidor con cargas de trabajo variadas con balanceo de procesador automático con particiones sin limitación de capacidad.

***“Además de para consolidar servidores físicos, el iSeries proporciona una vía fácil para integrar entornos múltiples. iSeries es el servidor más completo para la integración, y ha proporcionado ventajas evidentes e inmediatas.”***

Jan van de Straat, Director of R&D  
Gemeente Harlem



# System i 570 Performance

*Providing up to 2x performance over 570 with POWER5 1.65 GHz*

Workload	POWER4	POWER5 1.65GHz	POWER5+ 2.2 GHz	POWER6 4.7 GHz
CPW 16-core	20,000 CPW	44,700 CPW	58,500 CPW +31% POWER5	76,900 CPW +72% POWER5 +31% POWER5+
Trade 6 JDBC 2- tier (WebSphere, 32 bit J9) 4-core	N/A	1,517 tx/s	2,045 tx/s +35% POWER5	2,980 tx/s +96% POWER5 +46% POWER5+
SAP BI Datamart* 4-core	N/A	N/A	51,875	92,716  +79% POWER5+
MCU (Domino Mail and Calendar Users) 4-core	N/A	26,600 MCU	34,500 MCU +30% POWER5	47,500 MCU +79% POWER5 +38% POWER5+

IBM System i 570, 2 processors / 4 cores / 8 threads, POWER6, 4.7 GHz, 128 KB L1 cache and 4 MB L2 cache per core, 32 MB L3 cache per processor, 64 GB main memory i5/ OS V5R4M5 with DB2 for i5/OS. SAP BI Data Mart standard NetWeaver 7.0 (2004s) two tier application benchmark performed June 1, 2007 in Rochester MN 92716 Query Navigation Steps The SAP certification number was not available at press time and can be found at the following Web page: [www.sap.com/benchmark](http://www.sap.com/benchmark).



# Flexible System x Portfolio for Your Critical Workloads

Enterprise X-Architecture™

Scale Up / SMP Computing

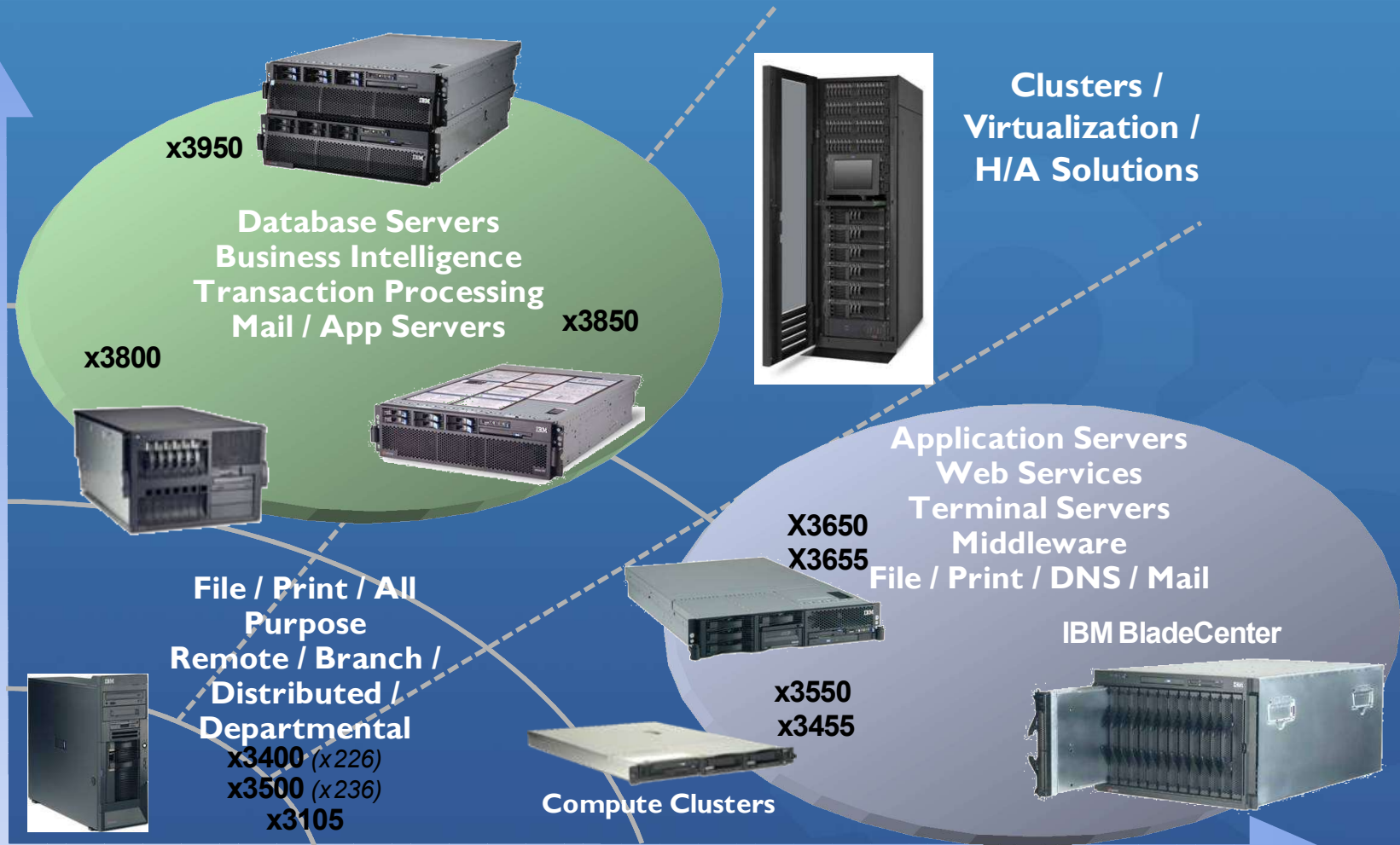

Scale Out / Distributed Computing

**Xtended Design Architecture**



# IBM BladeCenter



**Up to 4 processors  
per blade**



**Up to 14  
blades  
per chassis**



**Up to Six 7U  
chassis per rack**

*Full performance and manageability of rack-optimized platforms ...  
... at TWICE the density of most comparable non-blade 1U servers*



# Step 1 Consolidate Servers

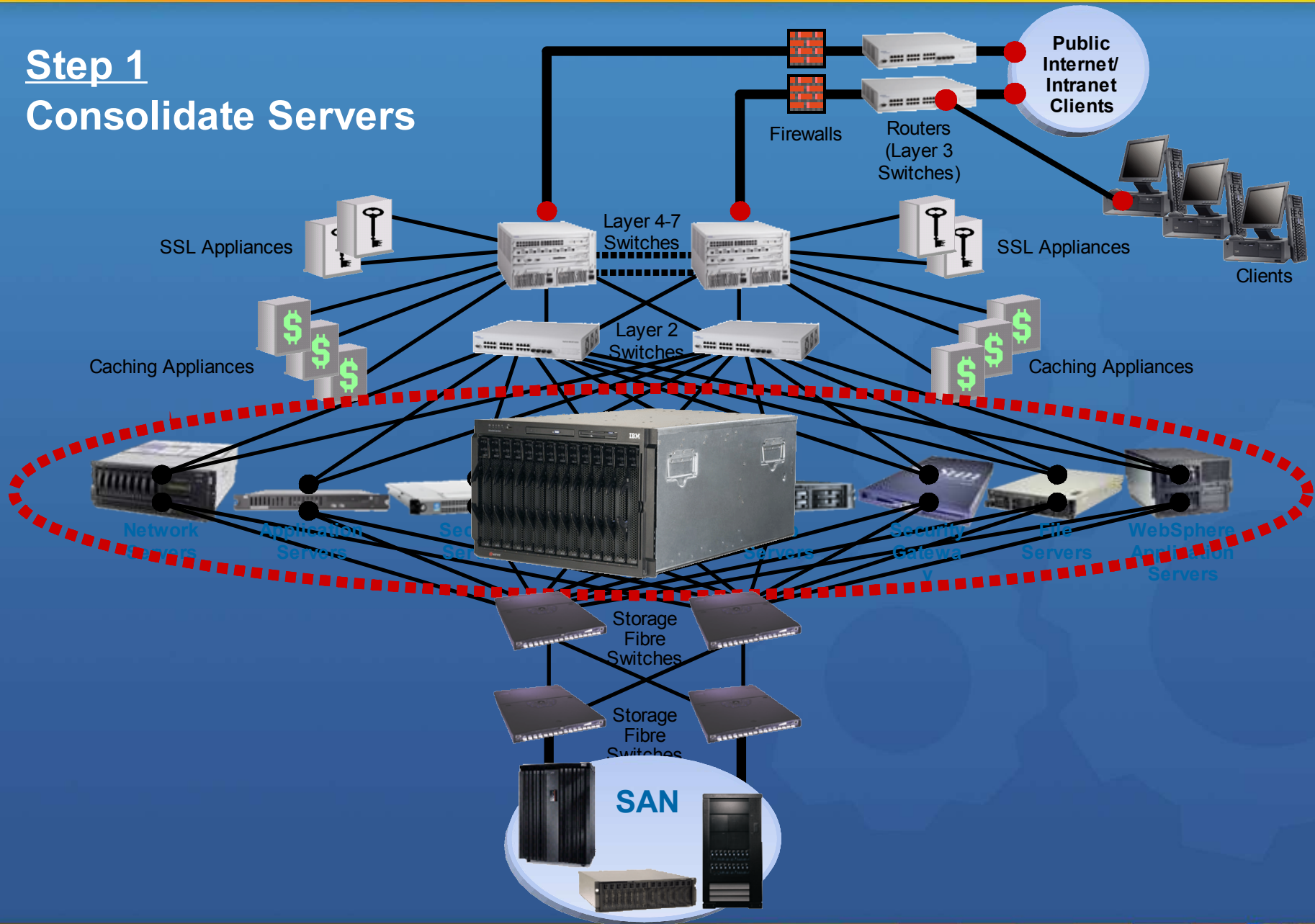

# Step 2 Integrate First Layer of the Network (L2)

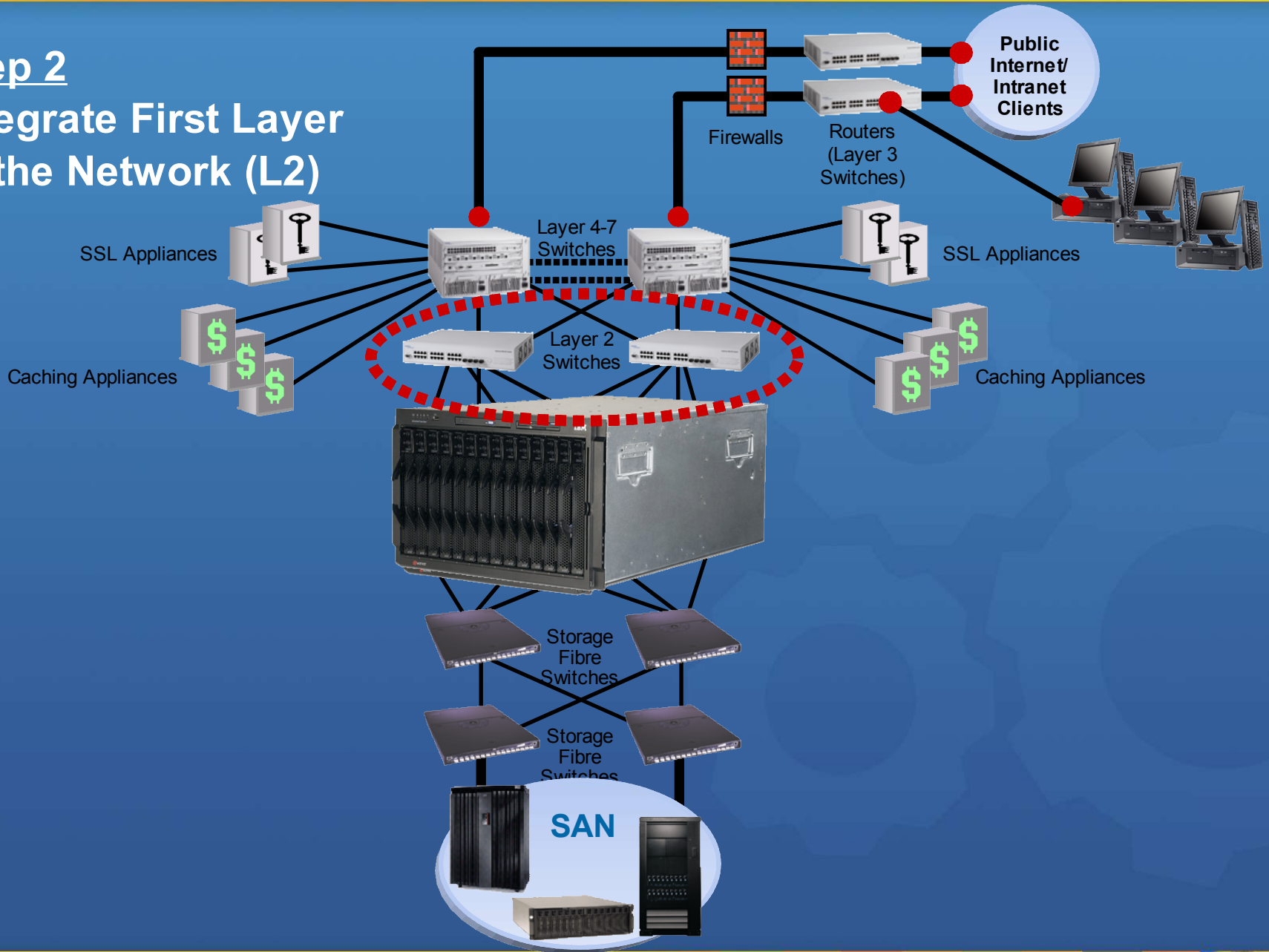



# Step 3 Integrate Storage Fabric

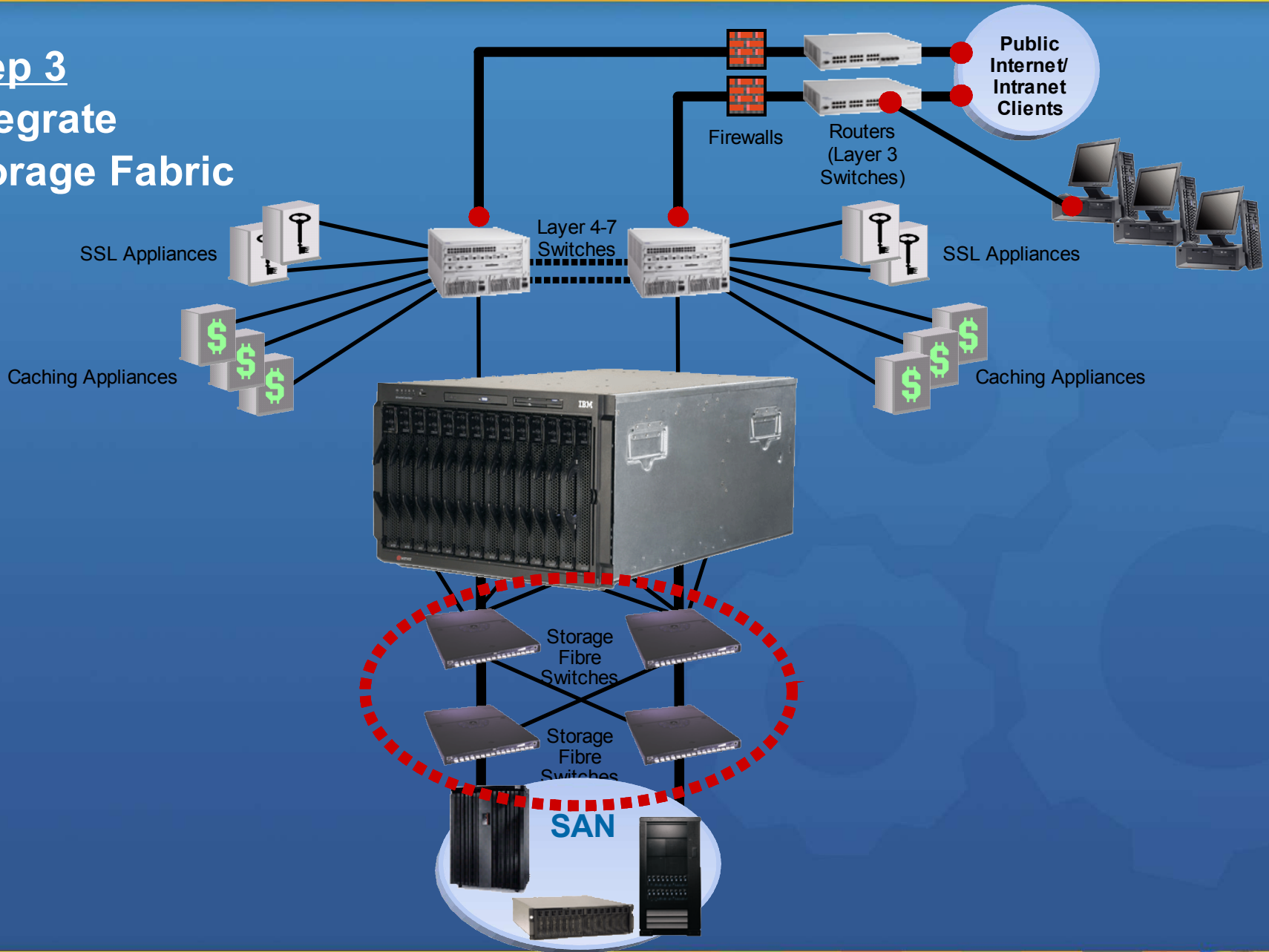

# Step 4 Integrate Second Layer of the Network (L4-7)

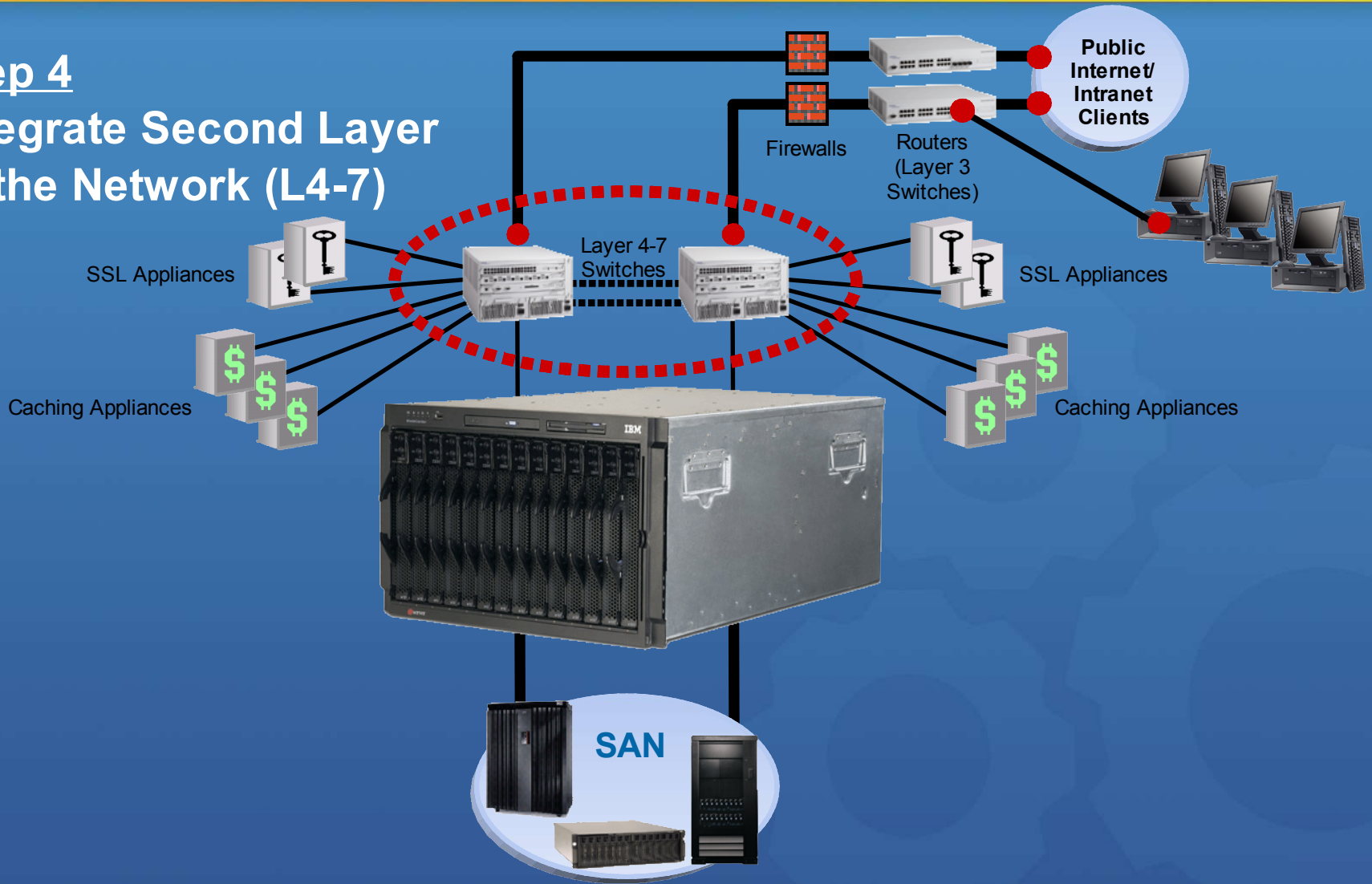

# Step 5

## Consolidate Applications

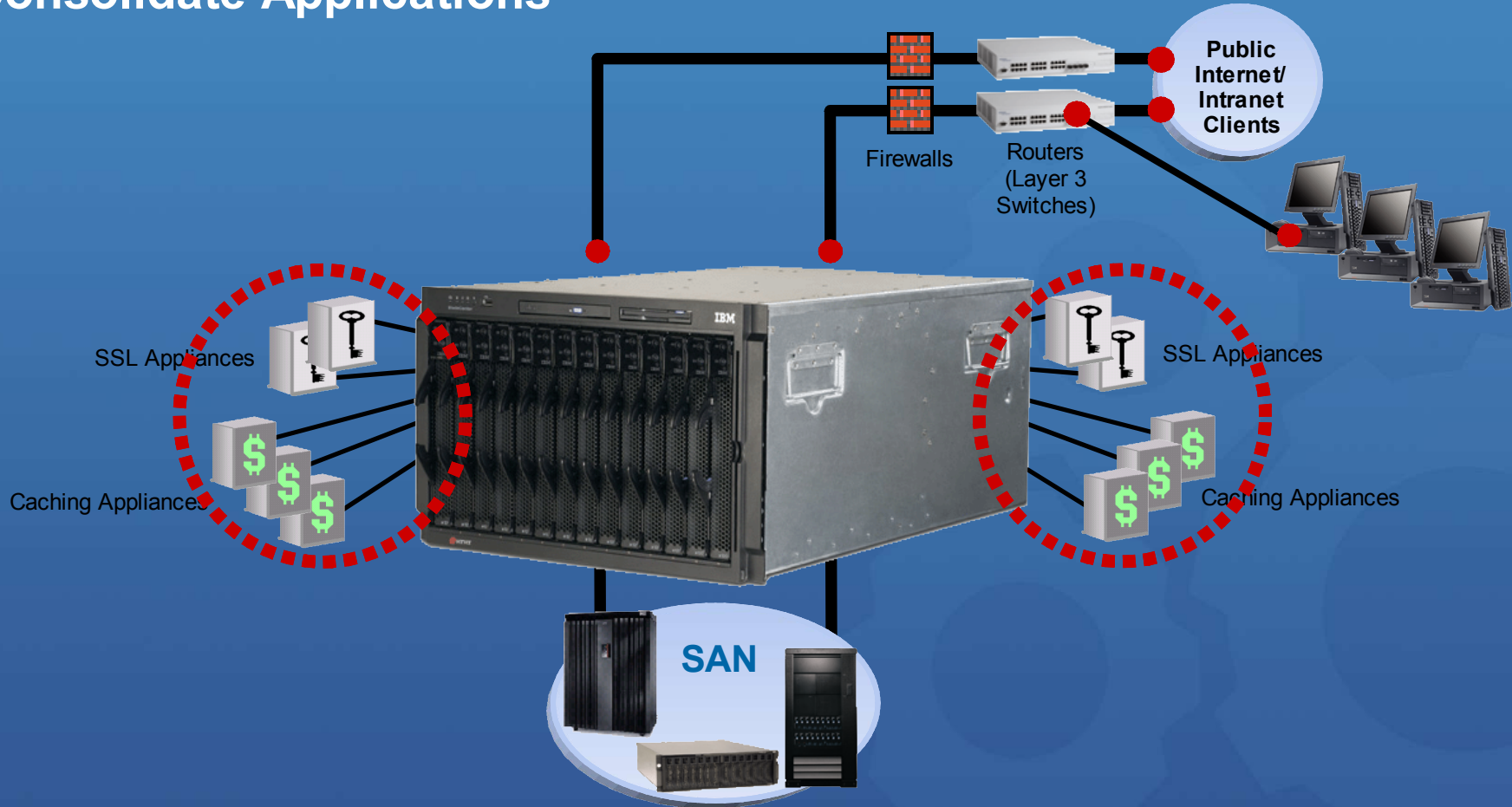

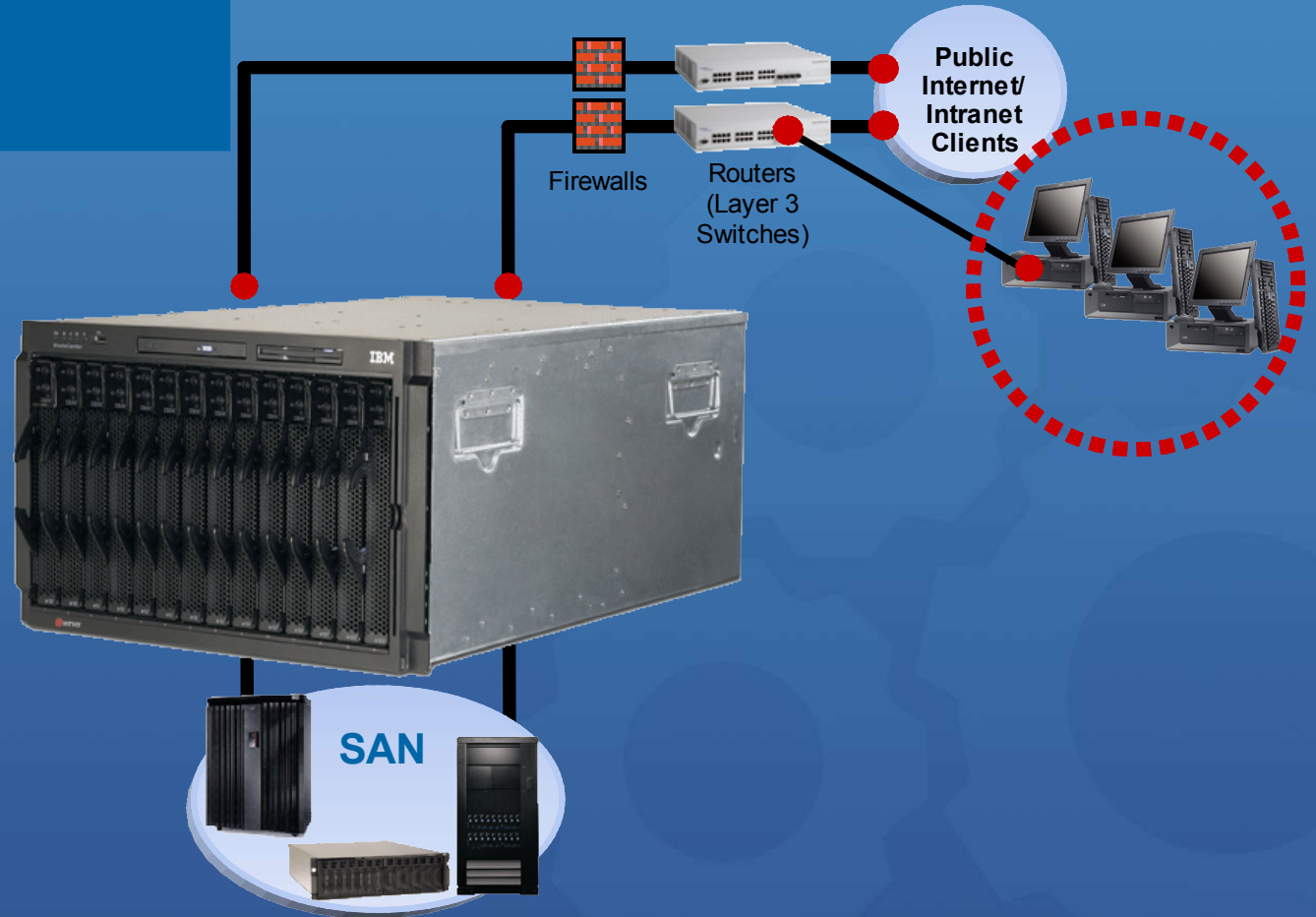

# BladeCenter Server Portfolio Continues to Build

Features

## HS21 2-way Xeon

- Intel Xeon DP
- EM64T
- Mainstream rack dense blade
- High availability apps
- Optional HS HDD

## HS41 4-way Xeon

- Intel Xeon MP processors
- 4-way SMP capability
- Supports Windows, Linux, and NetWare

## JS21 POWER-based

- Two PowerPC® 970 processors
- 32-bit/64-bit solution for Linux & AIX 5L™
- Performance for deep computing clusters

## LS21/41 2/4-way Opteron

- Two socket AMD
- Single and Dual core
- Similar feature set to HS20

Target Apps

- Edge and mid-tier workloads
- Collaboration
- Web serving



- Back-end workloads
- Large mid-tier apps



- 32- or 64-bit HPC, VMX acceleration
- UNIX server consolidation



- 32- or 64-bit HPC
- High memory bandwidth apps



**One Common Chassis and Infrastructure**



# Extend blade benefits to your entire business

*Chassis tailored to your specific needs...*



**IBM BladeCenter S**  
*Distributed, small office,  
easy to configure*



**IBM BladeCenter E**  
*Enterprise, best energy,  
best density*



**IBM BladeCenter H**  
*High performance*



**IBM BladeCenter T**  
*Ruggedized*



**IBM BladeCenter HT**  
*Ruggedized,  
high performance*

- A common set of blades
- A common set of industry-standard switches and I/O fabrics
- A common management infrastructure

# Expanding BladeCenter Ecosystem

- Wide range of companies convinced that BladeCenter architecture will add value to their customers' solutions
- Industry-leading technology companies delivering innovative business solutions running on Windows, Linux, Novell
- More choices for customers



# La familia IBM System Storage DS

**Entry point**

**DS3000**

**Unified series**

**DS4000**

**Enterprise-class storage in a small, modular package**

**DS6000**

**Leading the industry in functionality, performance, TCO**

**DS8000**

Common management platform

Common suite of copy services

Virtualization

Compelling price points

Industry leading service and support

## Enterprise-class Storage Continuum

### IBM System Storage DS Family innovations help you:

**Simplify** the underlying IT infrastructure of storage and its management to lower cost and complexity while increasing the ability to respond to changing needs.

- Assure **business continuity**, security and data durability.
- Efficiently manage information **throughout its lifecycle**, relative to its business value.





# N series Hardware Portfolio

All Systems share the same:

- Network Protocols: NAS, iSCSI, FC SAN ...*simultaneously*
- Operating system
- System management tools
- Storage management tools
- Multiple RAID levels ... *including double parity*
- High availability features ... *hot swap and redundancy*
- Disk Drives: FC & SATA ... *intermixed on all systems*
- Non-erasable, Non-rewritable WORM data protection
- Advanced software features and functions\*

\* Some features not available on gateway models

**N5200**  
Gateway



**N5500**  
Gateway



V3020  
N5200

V3050  
N5500

N5600

**N7600**  
Gateway



V6030  
N7600

**N7800**  
Gateway



V6070  
N series  
6070

**N5200**

**N5500**

**N5600**

**N7600**

**N7800**



**N370**



16TB

84TB

168TB

252TB

336TB (non-clustered)

420TB (clustered)

336TB (non-clustered)

504TB (clustered)

# IBM LTO4 Product Family

Drive-through Performance,  
Advanced Features

## TS2340 or TS2230 External Tape Drives

- One LTO3, LTO4, or HH LTO3 Drive
- SCSI LVD attach and/or 3 GB SAS (LTO4 only)
- Desktop or Rack Mount



## TS3100 Tape Library

- One LTO3 or LTO4 Drive or up to two HH LTO3 drives
- SCSI LVD, 4 Gbps FC and/or 3 GB SAS (LTO4 only) attach
- Desktop or Rack Mount



## TS3200 Tape Library

- One or two LTO3 or LTO4 Drive or up to four HH LTO3 drives
- SCSI LVD, 4 Gbps FC and/or 3 GB SAS (LTO4 only) attach



## TS3310 Tape Library

- Up to 18 LTO3 or LTO4 Drives
- SCSI LVD (LTO3 only), 4 Gbps FC and/or 3 GB SAS (LTO4 only) attach
- Modular Scalable, up to 4 expansion units with base library
- Desktop or Rack Mount



## TS3500 Tape Library

- Up to 192 LTO3 or LTO4 Drives
- 4 Gbps FC attach
- Scalable, up to 15 expansion frames with base library
- High availability
- Advanced features and functions
- Support for mixing LTO drives with TS1120 technology
- Direct attach support for Tape Virtualization Engines



Enterprise

Midrange

Entry

Capacity Requirements,  
Exponential Data Growth





Lotusphere 2008: del 20 al 24 de Enero, ¡nos vemos en Orlando!



# Software Multiplataforma

## Lotus Domino Server - Microsoft Windows

Plataforma	Microsoft Windows 2003
Sistemas operativos	Standard, Enterprise y x64 Editions.
Procesadores	Intel Pentium o superior y compatibles

## Lotus Notes client

- Windows
- Linux

## Lotus Domino Server – AIX, Linux, y Solaris

Plataforma	IBM AIX	Linux	Sun Solaris
Sistemas Operativos	IBM AIX 5.3 <sup>(4)</sup> (64-bit)	Novell SuSE Linux Enterprise Server (SLES) 10 x86 (32-bit) y (SLES) 10 x86_64 (64-bit); Red Hat Enterprise Linux (RHEL) 5 (32-bit) y (RHEL) 5 (64-bit)	Sun Solaris 10 <sup>(4)</sup> (64-bit kernel)
Procesadores	PowerPC®	Intel Pentium o superior y compatibles	UltraSPARC III y superiores

## Lotus Domino Server - iseries, zseries, Linux on System z™

Plataforma	IBM System i <sup>5</sup>	IBM System z	Linux on System z
Sistemas Operativos	IBM i5/OS®, V5R4	IBM z/OS® Version 1, Release 7 o posterior IBM z/OSe Version 1, Release 7 o posterior	Novell SuSE Linux Enterprise Server (SLES) 10 on System z (64-bit); Red Hat Enterprise Linux (RHEL) 5 on System z (64-bit) –
Procesadores	IBM eServer™ iSeries™ 270, 810, 820, 825, 800-2464 and above, 520-0901 and above iSeries 270, 800-2464, 810-2465, and eServer i5 520-0901; models with 3100 CPW or higher are recommended.	Cualquiera de los soportados por la version de system z utilizada	Cualquiera de los soportados por la versión de Linux en System z utilizada.



# Software Multiplataforma

## Lotus Sametime

Sistema Operativo	Procesador
Linux x86 •Red Hat Enterprise Linux 4.0 Update 4 •SUSE Linux Enterprise Server 10.0	Intel Pentium III 800 MHz, or higher, recommended
Microsoft Windows •Windows 2000 server Service Pack 4 or later •Windows 2000 Advanced Server Service Pack 3 or later •Windows 2003 Standard and Windows 2003 Enterprise Editions Service Pack 1 or later	Intel Pentium III 800 MHz, or higher, recommended
Sun Solaris •Solaris 9 and 10	UltraSPARC III 1 GHz processor, or higher recommended; UltraSPARC III 550 MHz processor minimum.
IBM i5/OS, 5722SS1, Version 5 Release 3 or later	IBM eServer iSeries, IBM eServer i5, or IBM System i5 server models capable of running IBM i5/OS V5R3
IBM eServer pSeries (AIX) •AIX 5.3 Technical Level 5 (for 7.5.1 release)	Dual 475 MHz, or higher, IBM PowerPC processor recommended; Dual 375 MHz PowerPC processor minimum.



# Software Multiplataforma

## Lotus Quickr

Services for WebSphere Portal	Linux on x86 Windows
Services for Lotus Domino	AIX I5/OS Solaris Windows

## Lotus Connections

Servidor	<b>Red Hat Enterprise Linux® ES release 4 (Nahant Update 4)</b> <b>Windows 2003 server EE</b> <b>Windows 2003 Server SE</b>
Cliente	Windows XP Professional SP2 SUSE Linux Enterprise Desktop 10XGL

