



PLM Forum – May 30th 2006

Paperless Product Development

Using ENOVIA, CATIA, SMARTEAM & DELMIA



Table of Content

- Introduction
 - Automotive Supply Chain scenario (Engine OilPan design)
- Paperless Product Development (Background - OEM site)
 - Collaborative PLM Engineering Desktop – ENOVIA V5
 - Functional Modelling Design – CATIA V5
 - 3D Based Dimensioning/FT&A – CATIA V5
- Paperless Product Development (Shown here, Supplier site)
 - Workflow - SMARTEAM
 - Work Package Exchange/Reconciliator – SMARTEAM
 - Production Preparation based on 3D – DELMIA V5
 - 3D For All – 3DXML
- Questions / Answers

Demo Overall Scenario : Oilpan Design/Manufacturing

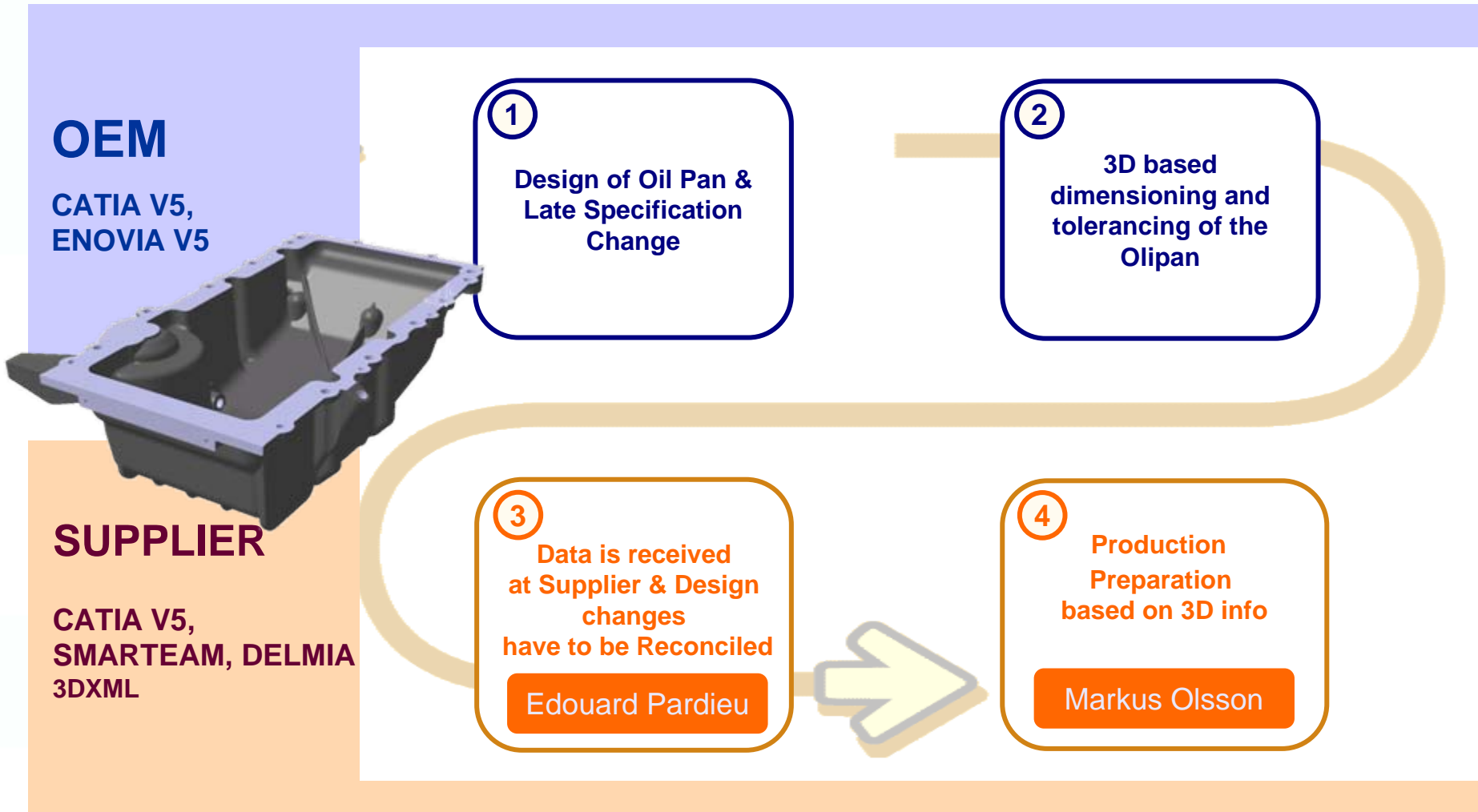

Oilpan Design....

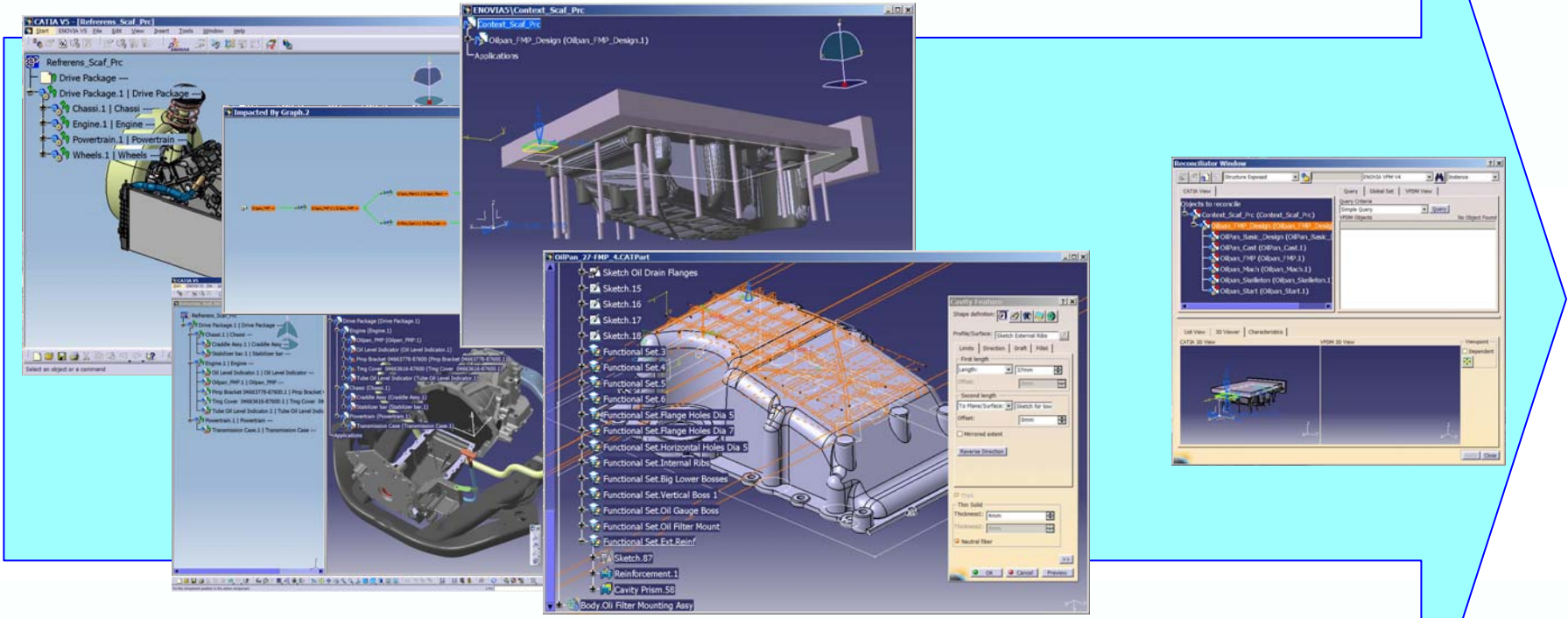

Demo Data (Oil Pan) -1/2

Reference-PRC

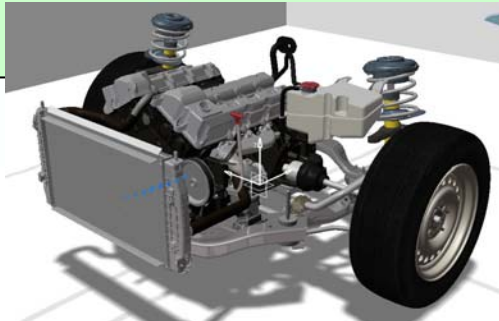
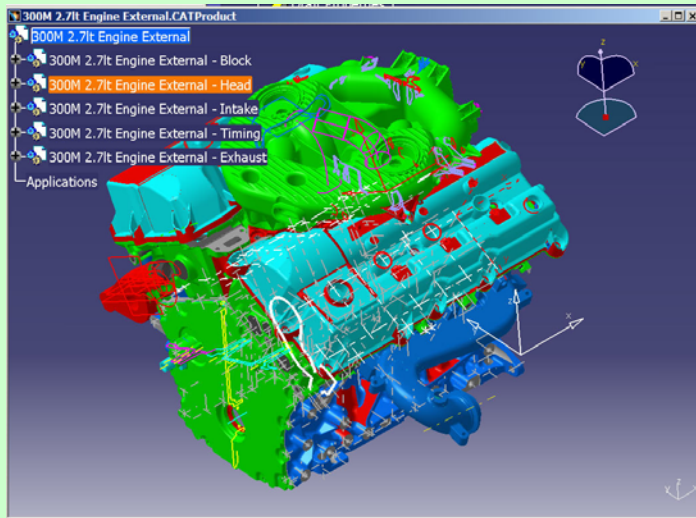

Design-PRC

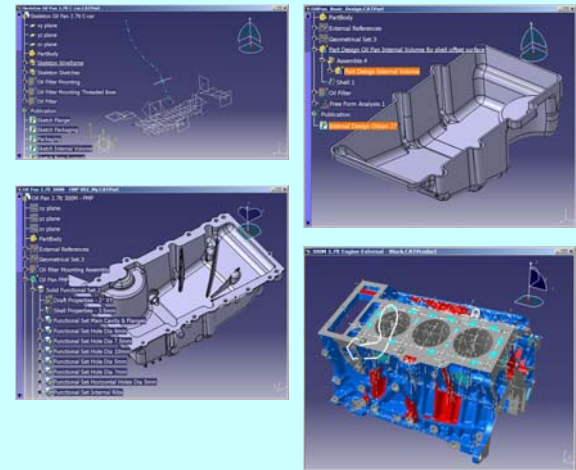

Demo Data : Oil Pan

Demo Data (Oil Pan) - 2/2

Skeleton

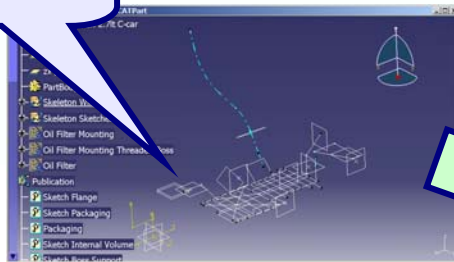

Final Part

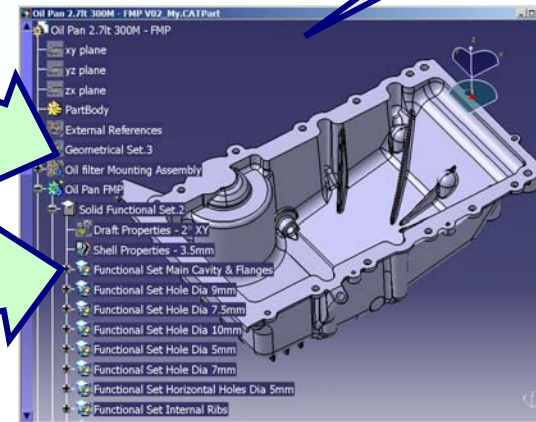

Basic Design

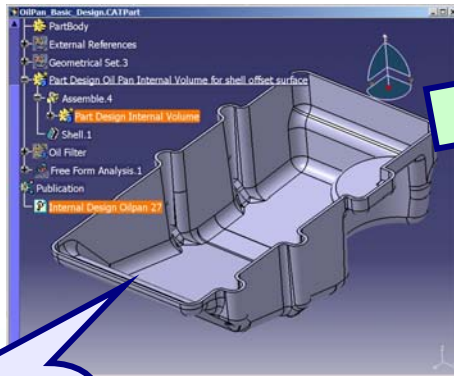

Summary...

OEM

CATIA V5,
ENOVIA V5

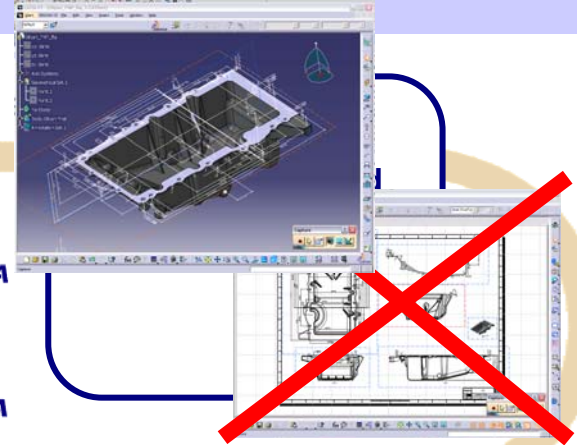
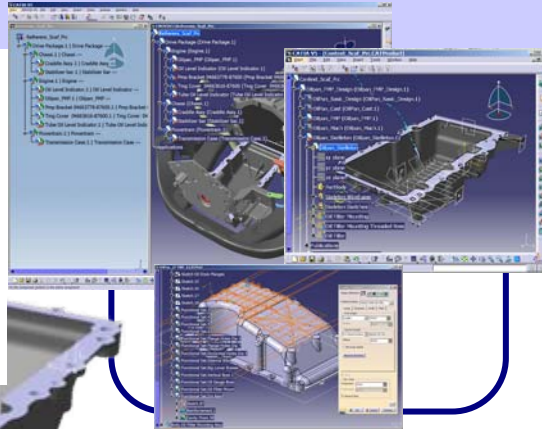

SUPPLIER

CATIA V5,
SMARTEAM, D
3DXML

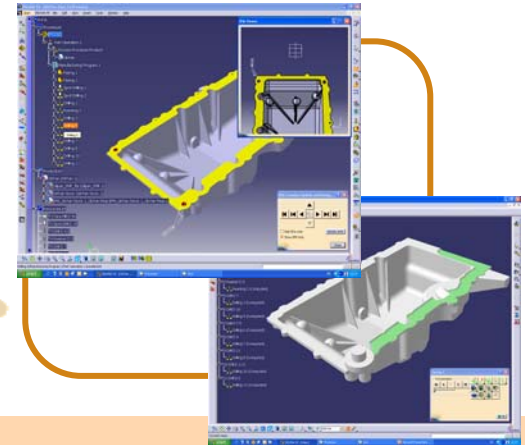
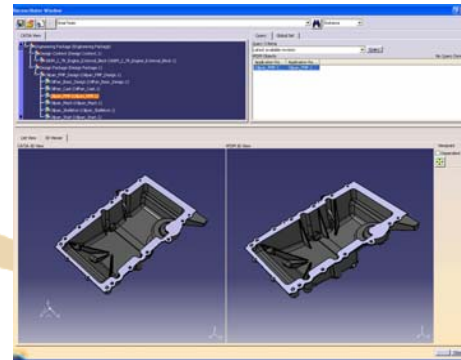

Initial Situation – Process Management with SMARTTEAM

- Engineering Package Exchange stored in SMARTTEAM that OEM has previously sent :

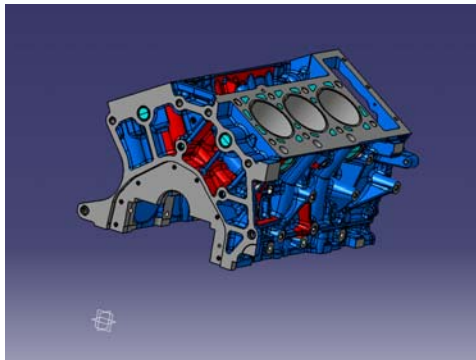

Engine Design Context

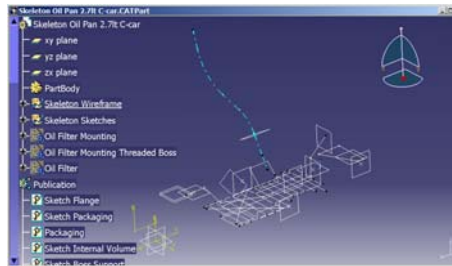

Skeleton

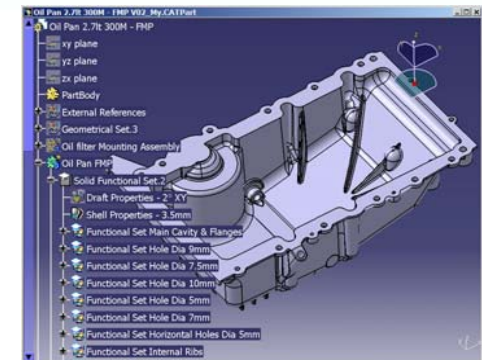

Oil Pan with 3 Ribs

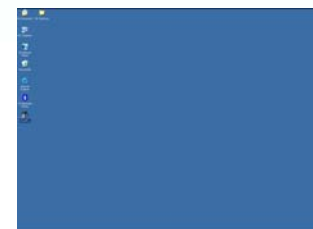
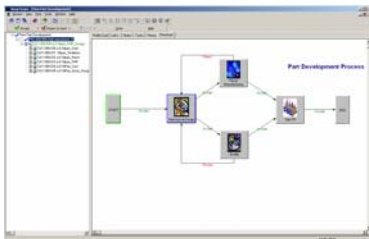

Reconciliator in SMARTTEAM : Reconciliation Scenario

1.a **OEM**
Late Skeleton Change

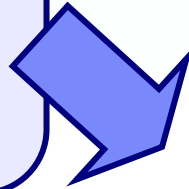

4.a **SUPPLIER**
Addition of 4 Ribs
to the Oil Pan



RECONCILE

4.b **SUPPLIER**
RECONCILES THE TWO
CONCURRENT CHANGES



Feature recognition

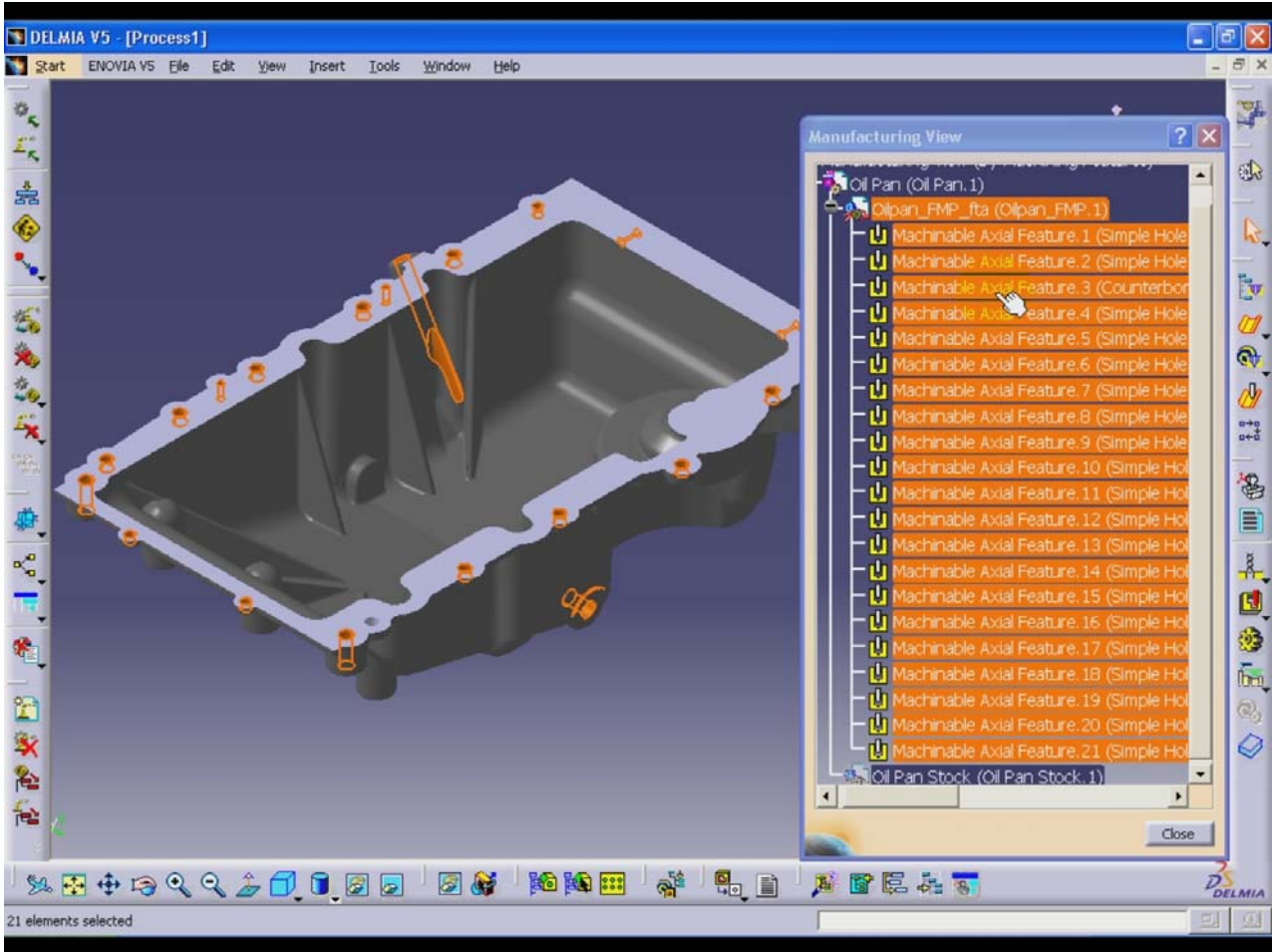

Process mapping

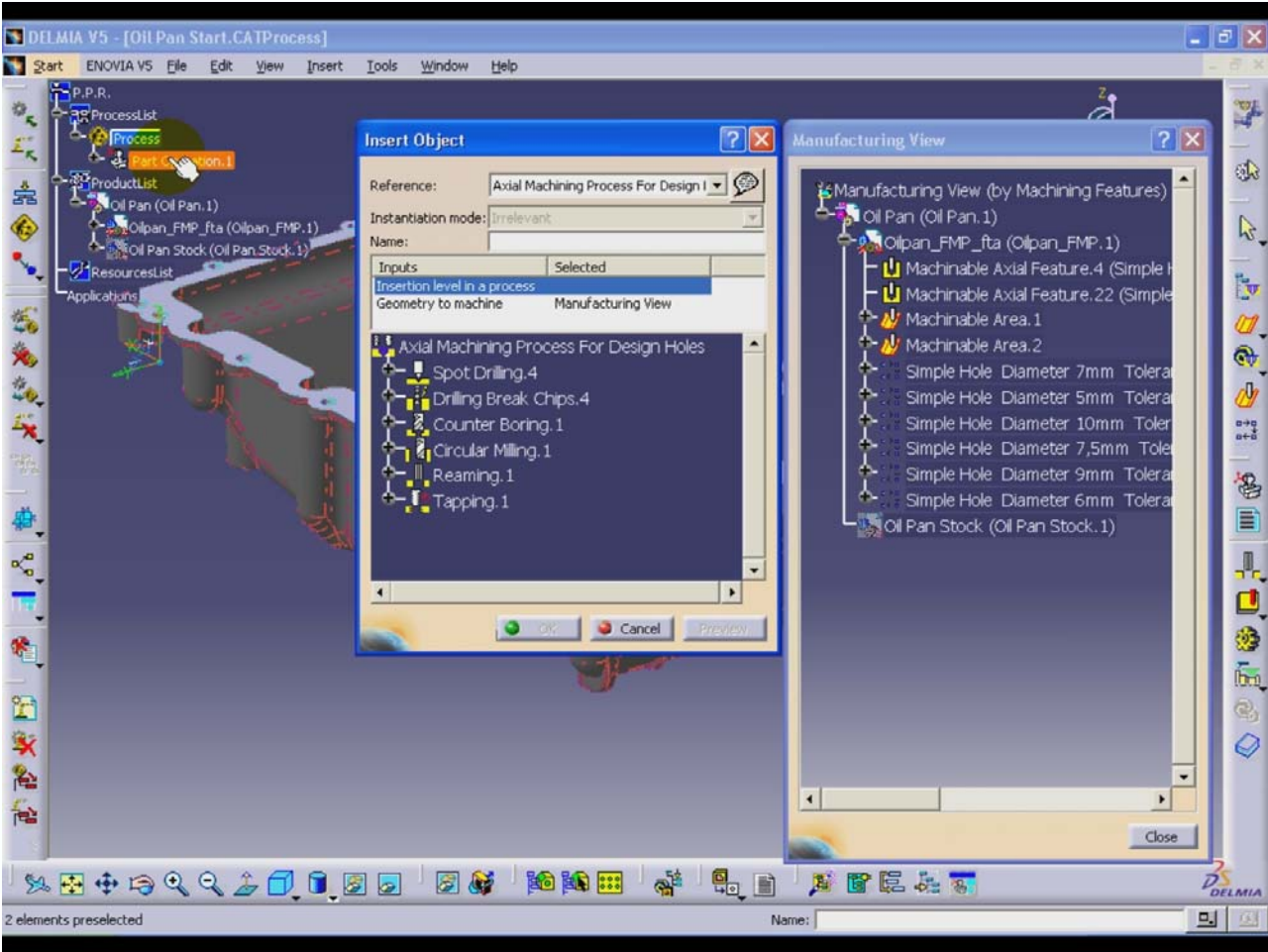

Process definition

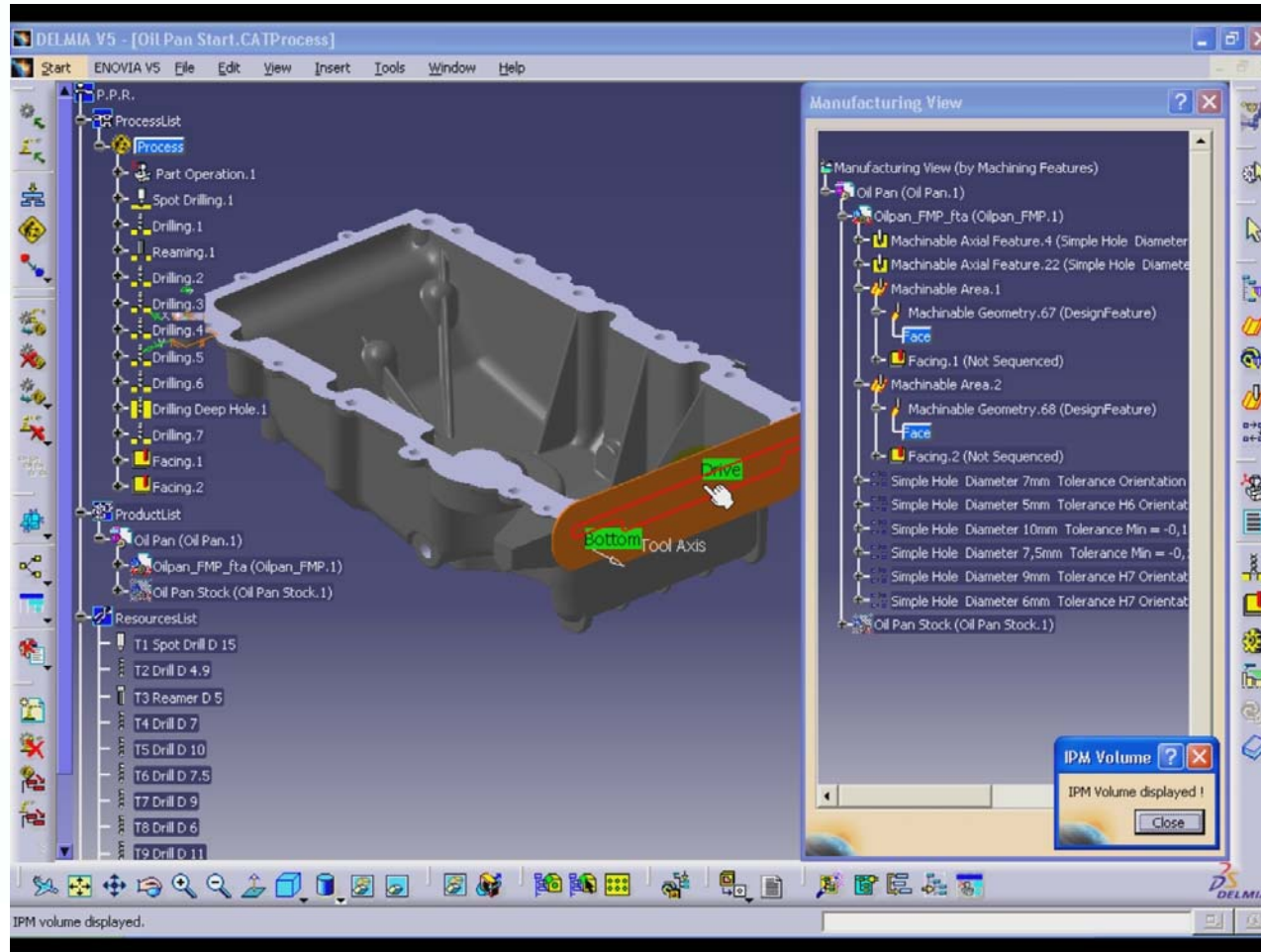

Process sequence

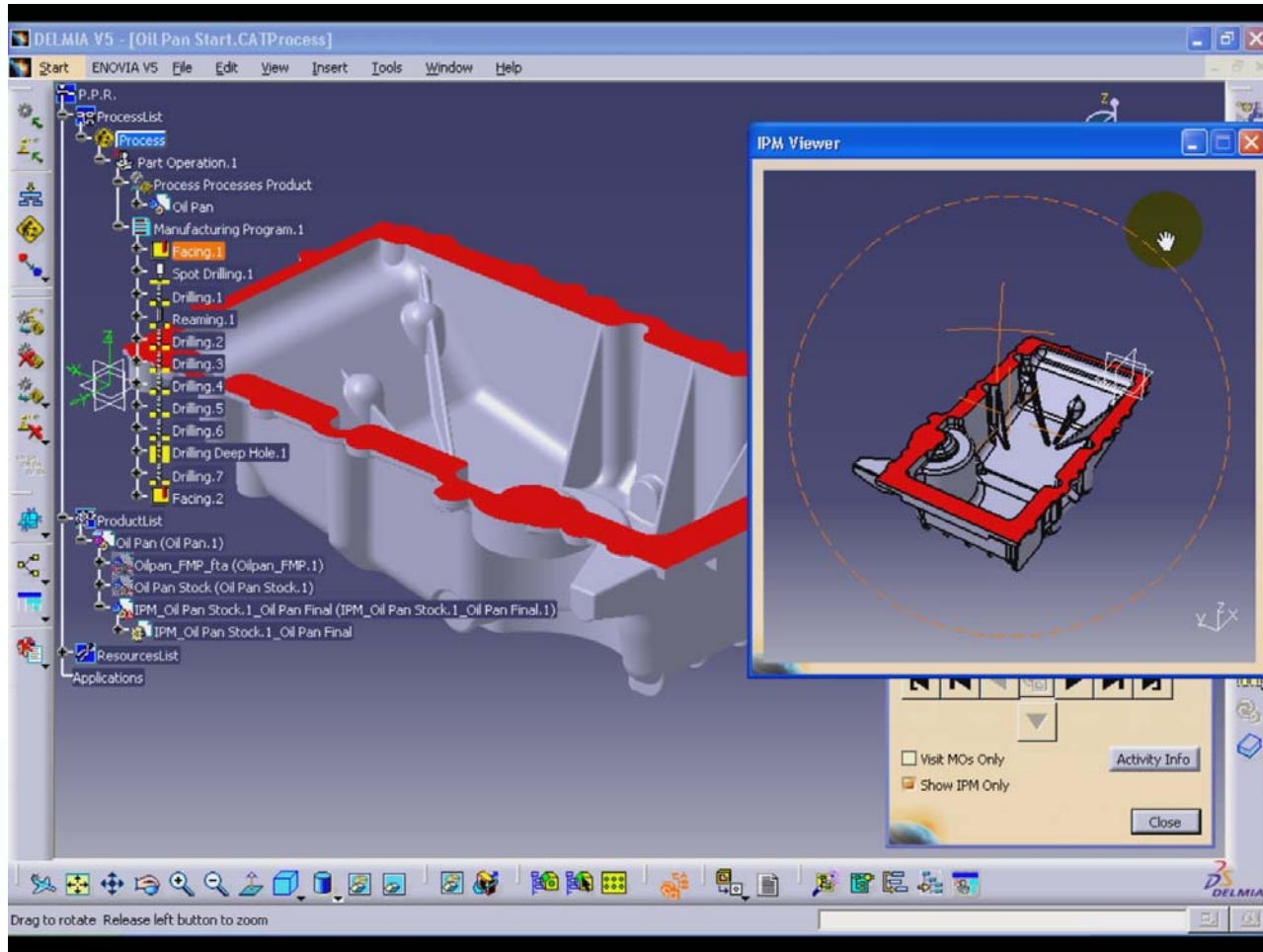

Process tolerances

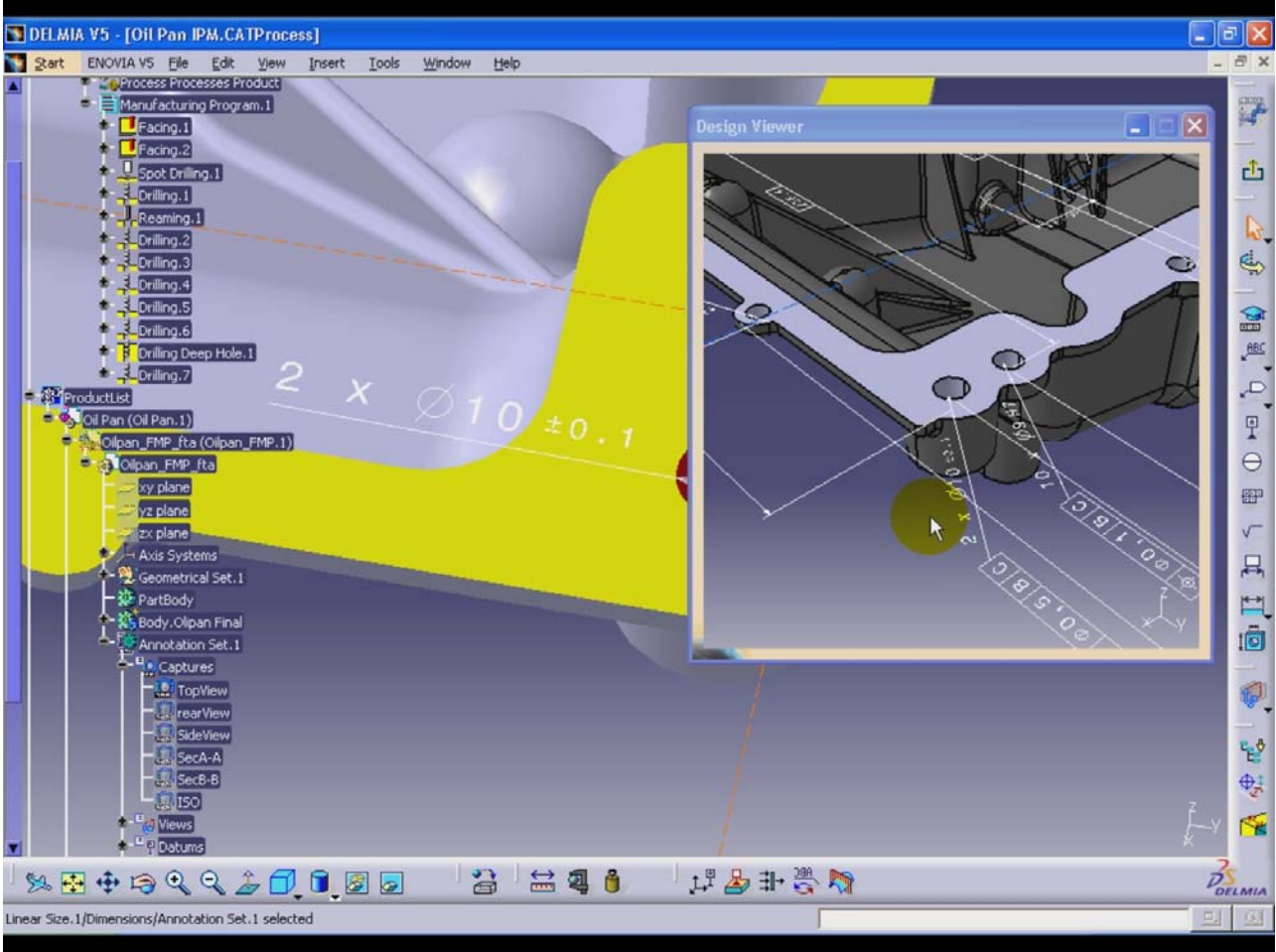

- Product List
 - Product
 - Product1
 - Oilpan_FMP
 - Annotation Set.1
 - Captures
 - Views
 - Reference Frames
 - Datums
 - Geometrical Tolerances
 - Dimensions
 - Roughness
 - Construction geometries

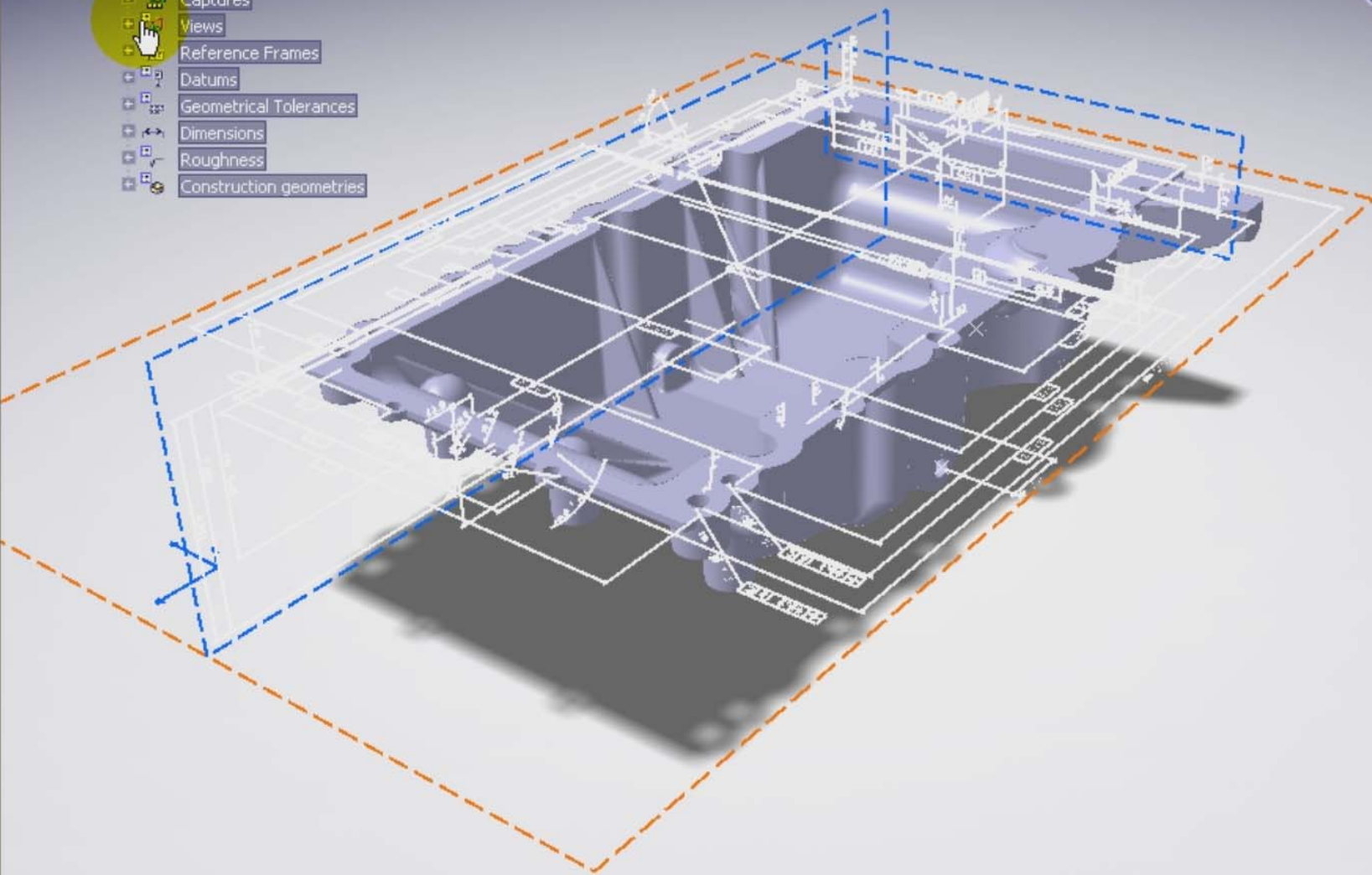
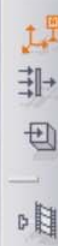
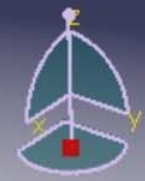

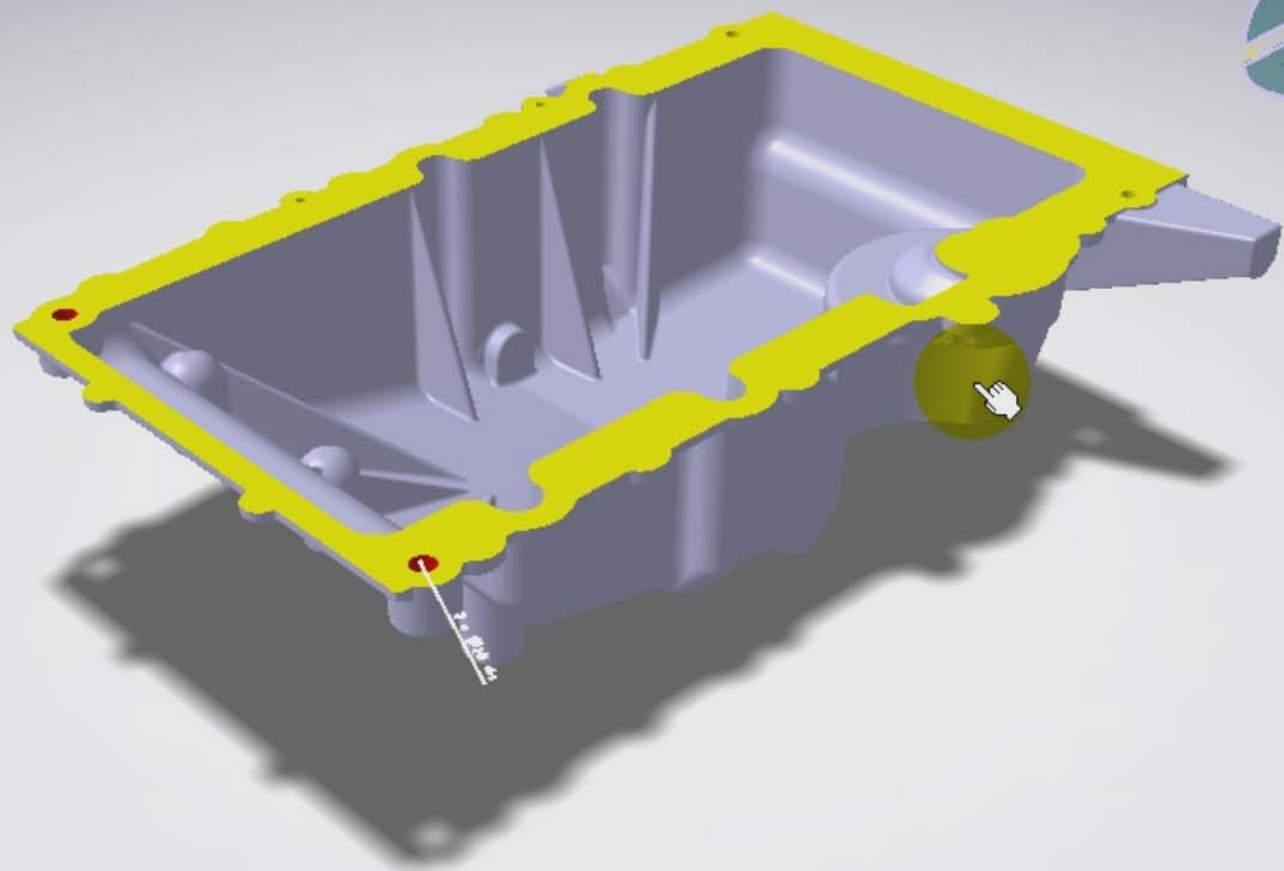
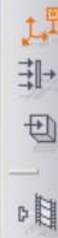

3D MASTER

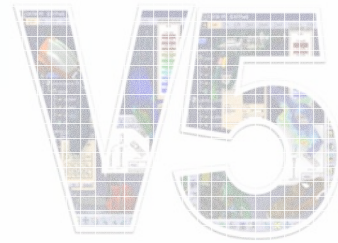

Paperless Product Development



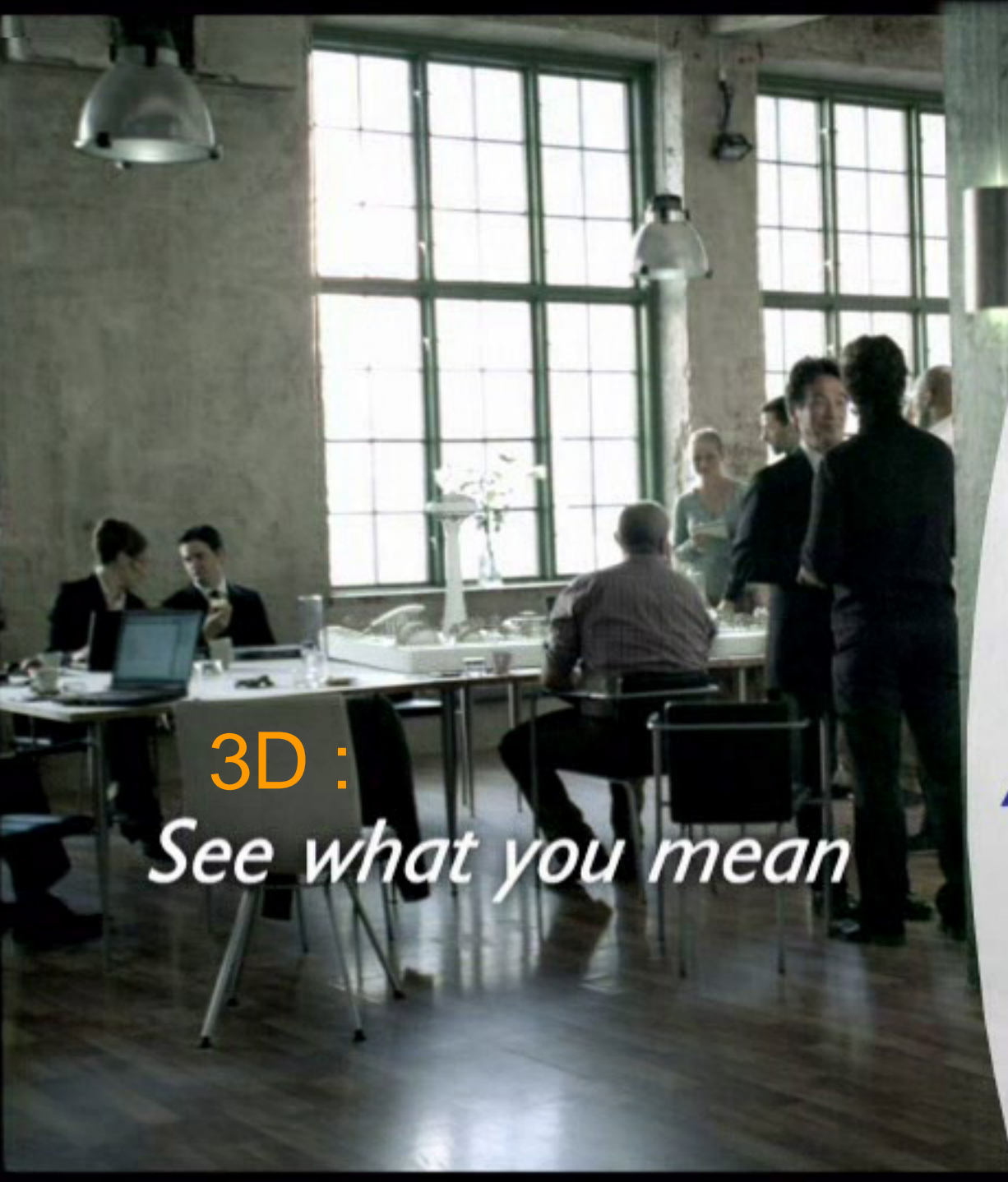

3D :
See what you mean

Thank You !

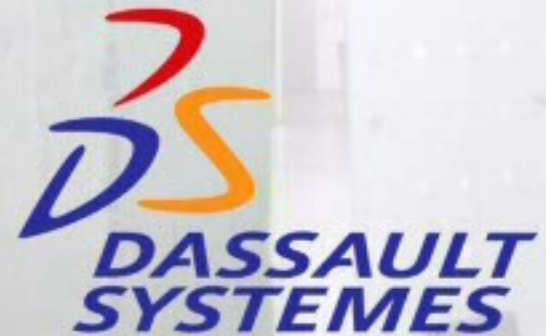

www.3ds.com

Summary

- Automotive Supply Chain Scenario
 - OEM is responsible for the car design
 - Supplier is designing and manufacturing some engine parts: OilPan
 - OEM is imposing Skeleton methodology in order to
 - ↳ Separate specifications from design
 - ↳ Flexibility and associativity of the relational design
 - OEM is using CATIA & ENOVIA
 - Supplier is using CATIA, DELMIA & SMARTEAM
- The OilPan design consists in
 - Skeleton: Specifications
 - Start Part, Basic Design Part => Persistent along the part life cycle for easy change mgt
 - Cast Part (or stock part): the part where the manufacturing start from
 - ↳ Foundry
 - ↳ Machining operation (drilling, facing)
 - Machining Part
 - Final Part:
- The Exchange between Supplier and OEM is achieved through
 - SEE Product (Supply Chain Engineering Exchange)
 - EPE Methodology (Engineering Package Exchange)
 - ↳ Design Context
 - ↳ Design Specification
 - ↳ Design Content
- 3D data is the master data along all the scenario
- Process Plan & Machining Specification (In Process Model with tolerances)