

Congratulations to Fiducia	Cover	IMS Tools Software Support	8-9
IMS SOA Solutions	2	IMS Education	10
IMS Abend Search & Notification	3	IMS Profiles	11
IMS Database Web Services	5	Editorial	12
Hot Web sites	7		

Congratulations to Fiducia, Winner of IOD Innovation Award: Best Solution Powered by IMS

Earlier this year, the IMS™ Newsletter had the privilege of profiling Fiducia’s participation in the IMS 10 Quality Partnership Program (*IMS Newsletter Volume 0801*). Today we highlight Fiducia’s recognition at the recent IBM Information On Demand conference in Las Vegas, Nevada, where they won the **IOD Innovation Award: Best solution powered by IMS!**



From left-to-right: Roger Ruppender, Rene Guigas, Sabine Zöller, Wolfgang Strauch, Reinhard Peyerl, Lothar Menzel and Carsten Menz

Fiducia is one of the 10 leading IT service providers in Germany with 45 years of IT experience.

They provide IT outsourcing and computer center services to 770 cooperative banks, 42 private banks, and several central financial institutions. Fiducia acts as an application service provider (ASP) for core banking applications, e-banking, e-brokerage and other financial institutions. They were one of the first IMS customers in Germany, and they have been an IMS customer for more than 30 years.

Fiducia’s current IMS environment consists of both IMS database and IMS transaction management systems, with full-function, HALDB, and DB2® databases. Currently they execute approximately 50 million transactions on a normal business day. At the end of a month or a quarter, which is considered peak time, they see transaction rates of up to 70 million per day.

Connectivity is handled mainly through IMS Connect and MQSeries®; however, a small number of APPC and 3270 connections still exist. All of the main banking systems participate in a 2-way data-sharing sysplex. Five of these banking systems have already migrated to Shared Message Queues (SMQ), and the other three systems are due to follow later this year. SMQs allow Fiducia to provide their application systems with the highest availability possible. One IMS can process the messages if the other becomes unavailable for a planned or unplanned outage.

Fiducia has many connections to several other IMS installations, which are made using Multiple Systems Coupling (MSC) links. They needed VTAM® Generic Resource (VGR) support for these links before they could continue with their SMQ implementation. MSC VGR support allows them to manipulate their IMS systems within the SMQ without affecting their partner institutions from an availability or definitional point of view. Fiducia’s participation in the IMS 10 QPP ensured that they would have the earliest availability of the MSC VGR support. They have since successfully migrated all 24 of their IMS systems (11 test, and 13 production systems) to IMS 10. MSC VGR has been running in their pre-production environment since mid-February 2008. In addition, their testing of the IMS 10 Dynamic Resource Definition capability—which enables databases,

transactions, and programs to be defined dynamically using commands—proved so successful that it has now replaced a separately priced tool, in both their test and development environments. Fiducia introduced DRD into the first production environment in May of 2008,

and DRD is now used in all 24 systems, including production!

Fiducia’s goals were to improve IMS connectivity to their partner institutions, and to reduce operational costs. By installing IMS 10 with its support of MSC VGR, Fiducia was able to leverage its investments, utilize the SMQ function to provide the highest availability possible to their customers, and eliminate the cost of third party tools. In meeting these objectives, Fiducia was named the winner of the IOD Innovation Award: Best solution powered by IMS. Congratulations to Wolfgang Strauch, Fiducia IT AG, and all of the team members who contributed to the successful implementation with IMS 10!

Overall, we feel that IMS 10 is a good and stable version. The support we received during the QPP itself was, in a word, "perfect." Problems that were encountered within production systems were solved promptly. Finally, we have found that the CPU usage differential between IMS 9 and IMS 10 is non-existent. – Wolfgang Strauch

Get Your Hands on IMS SOA Solutions and Rational Tooling. Right here! Right now!

Yee-Rong Lai IMS Information Developer Shahin Mohammadi-Rashedi IMS Process Tools

Have you ever wondered how you can find the time and resources to install the software needed to evaluate, try out, and learn the solutions that could enable IMS for service-oriented architecture in your organization? Have you always wanted to download IMS SOAP Gateway, IMS TM Resource Adapter, or the free trial version of IBM® Rational® Developer for System z® (for IMS Version 10 customers), but were never able to do so?

You can now explore a series of hands-on exercises *right from where you are*—the only requirement is an Internet connection. You can transform an IMS application into a Web service by using IMS SOAP Gateway. You can access IMS assets from an external Java application or Web service that is outside of the IMS installation by using the IMS TM resource adapter.

The **IBM Enterprise Modernization Sandbox for System z** lets you evaluate the IBM Enterprise Modernization solutions for System z through practical, hands-on experience. The sandbox provides an environment that makes it easy and fun to quickly try practical scenarios guided by self-paced exercises, *without installing or configuring software* in your environment. Each set of exercises covers the key concepts and steps for implementing the solution, and provides all the sample files that you will need.

When you register at the IBM Enterprise Modernization Sandbox for System z architecture entry point, you can access IBM Rational Developer for System z, IMS SOAP Gateway, IBM WebSphere® Application Server, and IMS TM Resource Adapter, all installed in an online environment. You also have access to a mainframe test environment that lets you quickly deploy and test the scenarios.

When you start any of the online trials in the System z sandbox, you will have four hours to explore the products and exercises within the sandbox. You can exit and log back in any time during this four-hour period without resetting your sandbox environment.

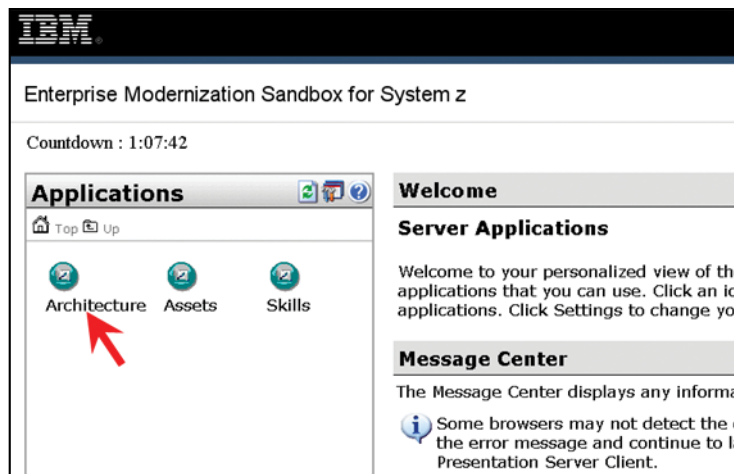

Figure 1. Click the Architecture icon to start your trial

To play in the sandbox

1. Go to the IBM Enterprise Modernization Sandbox for System z architecture entry point at www.ibm.com/developer-works/downloads/emsandbox/systemz/architecture/?S_TACT=105AGX28&S_CMP=EMSAND.
2. In the Online trial prerequisites section, follow the link to download the Citrix XenApp client. The online trial program uses the Citrix Access Platform to provide a connection from your workstation to a remote IBM server running the IBM product you are evaluating. This is a one-time installation. Select the version based on your operating system. For example, for Windows XP, Vista, 2003, or 2000:
 - a. Select the [XenApp Plugin](#) (new name for Client) from the list of clients.
 - b. Download [XenApp Plugin for Hosted Apps](#).
3. Install the [Citrix XenApp](#) client. If you are prompted for a server address, simply ignore it and continue.
4. After the installation is complete, restart your browser.

You can now go back to the IBM Enterprise Modernization Sandbox for System z architecture entry point that is listed in Step 1 and register for the trial.

Tips for more fun in the sandbox

Tip 1:

Instead of switching back and forth between a browser window for the instructions and the Citrix XenApp client window, you can print out the PDF version of the instructions so you can have it readily available at your desk. Each set of the exercises provides a PDF version for the entire set, as well as an option to print just the exercise you are on.

Tip 2:

To continue working beyond the end of a four-hour session, simply save your materials and register to begin the trial again. You will need to refresh your desktop and other settings when the trial reopens to continue where you left off.

continued on page 5...

IMS Abend Search and Notification: Problem Determination Simplified!

Dario D'Angelo, Kin Lau, Alan Smith, IMS Reliability, Availability, and Serviceability

IMS Version 10 introduced a new function that enables quicker understanding of abends and facilitates the problem source identification process. The Abend Search and Notification function (ASN) captures relevant, symptom-specific information at the time of an IMS system failure. With this information, an e-mail is automatically constructed and sent to a set of recipients defined at installation time.

Specifically, ASN provides the following advantages:

Automates the notification to system programmers and other designated recipients in case of a system failure.

Provides direct access to the abend description and debugging procedure (when available).

Facilitates the problem source identification with hyperlinks pointing to documentation of known problems with the same or similar symptoms.

Provides necessary resources (such as help information and diagnostic procedures) to reduce the “know-how” needed to find a solution to a problem.

This means that ASN not only immediately notifies of system failure, it also provides access to relevant documentation and potentially, even the solution to the problem experienced. In other words, the e-mail will contain hyperlinks to online references and databases with a collection of symptom-specific hits.

At your service

If the received abend has been previously reported, the fix is just a single click away. This concept aligns with IBM's direction to make all the serviceability-related information available to customers seamlessly, anytime, and anywhere.

Beyond its notification capability and references to information such as abend description, abend diagnosis procedures, and previously reported problems, e-mail that is generated by ASN also contains hyperlinks to the following types of information:

APARs, PMRs, and Technotes matching the symptoms of the problem experienced.

The most recent Prevent Service Planning (PSP) bucket.

A hyperlink to order fixes online (PTF).

Contact information for technical support.

Furthermore, in order to easily identify the environment where the failure occurred, the following information is captured: IMS ID, IMSplex name (if available), the time of the ASN invocation, the abend code and associated return code (when meaningful), the module name involved in the abend (if available), and the latest maintenance level associated with the failing module.

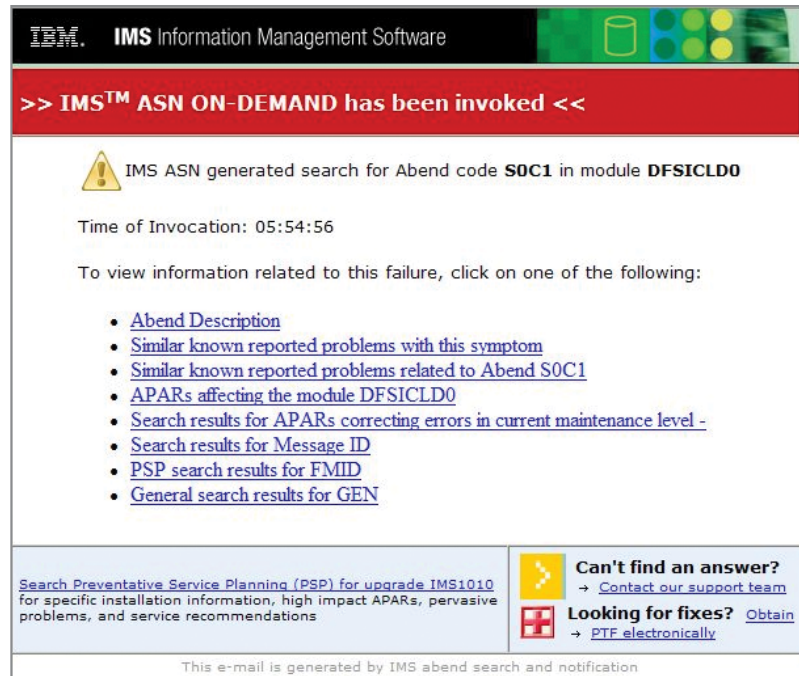

Figure 1. Example of an IMS ASN e-mail notification

Why IMS ASN?

If we consider that over 85 percent of all Problem Management Records (PMRs or ETRs) are either already known or non-defect related problems (that is, the problem resolution did not require a software fix), it becomes clear why it is worthwhile to implement this function.

Although ASN is not a silver bullet for all IMS failures, it does provide great benefit for customers because they can quickly identify and reliably diagnose the causes of the experienced failure and therefore, the solution to the failure.

Consider the sheer amount of critical data that IMS manages. It's critical that recognizing and solving a problem is done with the greatest efficiency. Here are some numbers that can help to quantify the importance of this issue:

Over 3 trillion dollars for a single IMS customer's transactions are processed daily

IMS Abend Search and Notification: Problem Determination Simplified! *continued...*

Over 50 billion transactions run through IMS every day

IMS serves around 200 million users every day

IMS manages over 15 billion GBs of production data

One IMS customer on one single IMS system runs nearly 100 million transactions per day

In these high workload environments, the costs associated with low reliability and the down time required for problem resolution is often intolerable. Although IMS is well known as a high availability system, the ASN function further reduces customers' down time with automatic notification, direct references to research materials, and quick discovery of previously reported system failure.

What else?

To take full advantage of IMS ASN functions, the IMS Message and Codes information and Diagnostic information have been merged and restructured to give not only a generic understanding of why the failure occurred, but also to provide instructions that can be used to perform some basic problem source identification.

Additionally, IMS ASN e-mails can be customized by users to fit the needs and requirements of any environment. An ISPF-driven interface allows users to modify every aspect of the e-mail content, from changing the words and text to adding more online references as hyperlinks, from specifying any number of recipients to making the graphics look and feel the way the user prefers. However, customization is not required, because IBM provides an initial sample of e-mail text that already contains hyperlinks to various online references.

If you consider e-mail notification to be too slow, IMS ASN includes the option to send messages to portable devices in the form of Short Message Service (SMS). Due to concerns about the screen size of mobile devices, the SMS message does not contain hyperlinks to the various online resources.

In addition to theabend-driven initiation of e-mails, IMS ASN also provides an ISPF on-demand interface for sending e-mails.

On the ISPF panel, you can:

Enter the criteria to be used to select the hyperlinks to online references.

Specify a different set of recipients to receive the notification e-mail.

Conclusion

With ever increasing system workloads, the availability and reliability of your IMS systems becomes more critical. As system complexity increases, the need to find new ways to improve or reduce the amount of time necessary to identify and solve a problem is vital.

IMS ASN provides an autonomic mechanism that instantaneously notifies customers of a critical failure and helps them to understand the cause of theabend. More importantly, it shortens system down time in case of failure by providing a quick and reliable way to find known and available solutions. 

Introducing the Installable Information Center!

Christi Guzik

IMS Information Development

You asked. We listened.

The Information Management Software for z/OS® Solutions Information Center is now available in English as an installable information center for Microsoft® Windows® XP systems. The installable information center can run on a local system or on an intranet server. With the installable information center, you have the flexibility to choose which product documentation to install, for only those products in which you are interested.

The installable information center includes the same content as the online information center, including product documentation for IMS™ Version 9, Version 10 and Version 11, DB2® for z/OS Version 8 and Version 9, a large number of IBM® DB2 and IMS Tools, DB2 QMF™ Version 8 and Version 9, the current versions of WebSphere® Replication Server and WebSphere Event Publisher, and more. IMS Version 11 is available through the update mechanism, and is not a part of the base installation.

The installable information center also features an update mechanism to help ensure that you always have the most current product documentation.

You can order the Information Management for z/OS Solutions Information Center DVD (SK5T-7377) from the IBM Publication Center: <http://ehone.ibm.com/publications/servlet/pbi.wss?CTY=US>. 

IMS Database Web Services: Small Tool, Big Results!

Marilene Noronha Roder IMS On Demand Integration Solutions Christopher Holtz IMS XML Database

40 years ago, IMS helped put a man on the moon. The technology that ensured the success of that Apollo project now runs the world's most mission-critical applications across Financial, Retail, Transportation, and Manufacturing industries. In fact, over 95% of top Fortune 1000 companies use IMS.

However, IMS's own nature poses some integration challenges regarding emerging technologies or other products. It's a hierarchical database and all its peers are Relational; its query language is DLI, not SQL; its data does not follow the standard format offered by other databases. How can we help IMS clients modernize and integrate their existing applications, thereby preserving the significant financial and human investments they've already made?

IMS Database Web Services is the latest offering in a suite of no-charge tools that helps our clients modernize and integrate IMS. IMS Database Web Services is an extension to the DLIModel utility plug-in that provides a simplified way to expose the vast amounts of existing IMS data as Web Services.

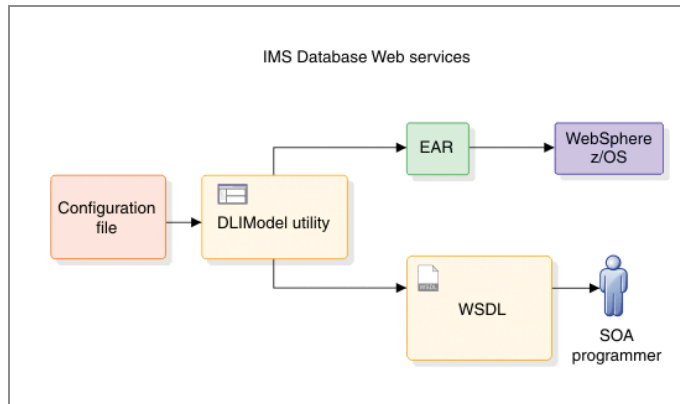

Figure 1

The new Web Service extension of the DLIModel utility allows you to generate an IMS application by using a standard IMS DL/I call that identifies the data you want to expose. The generated IMS application is deployed on WebSphere Application Server for z/OS as an industry standard callable Web service.

The DLIModel tooling provides inline assistance to help you define the data that is to be exposed as Web services in an XML configuration file. After the configuration file is specified, the tooling will generate two artifacts, which are shown in Figure 1:

An Enterprise Archive (EAR): The generated IMS application that can interpret a SOAP input message, issue the defined DL/I call, and format the IMS result as standard XML to be returned

in the SOAP output.

A Web Services Description Language (WSDL) file: The WSDL file contains all the information needed by any consumer of the of the Web service. Without any IMS knowledge, an SOA programmer can set up, call, and interpret the results of your IMS database Web service in an industry standard way.

Using Commands to identify the data to be exposed

The user identifies to data to be exposed as Web Services in an XML configuration file. The data is specified through Command tags, and a configuration file can include several commands to retrieve, update, insert or delete IMS data.

Commands can have input parameters, and the values for those parameters can be set dynamically when the Web Service is invoked. It is also in the configuration file that the user specifies the PSB and PCB, which contain the data selected to be exposed. Each command in the configuration file will become a callable Web Services operation. Figure 2 shows an example of a getPurchaseOrder command that will be exposed as a callable web service.

continued on page 6...

Get Your Hands on IMS SOA continued...

Questions?

An Enterprise Modernization sandbox forum is set up for questions and answers: www-128.ibm.com/developerworks/forums/forum.jspa?forumID=1431

If you run into connection issues, check out the online trial connection troubleshooting forum at: www.ibm.com/developerworks/forums/forum.jspa?forumID=1235

Have fun in the sandbox! 

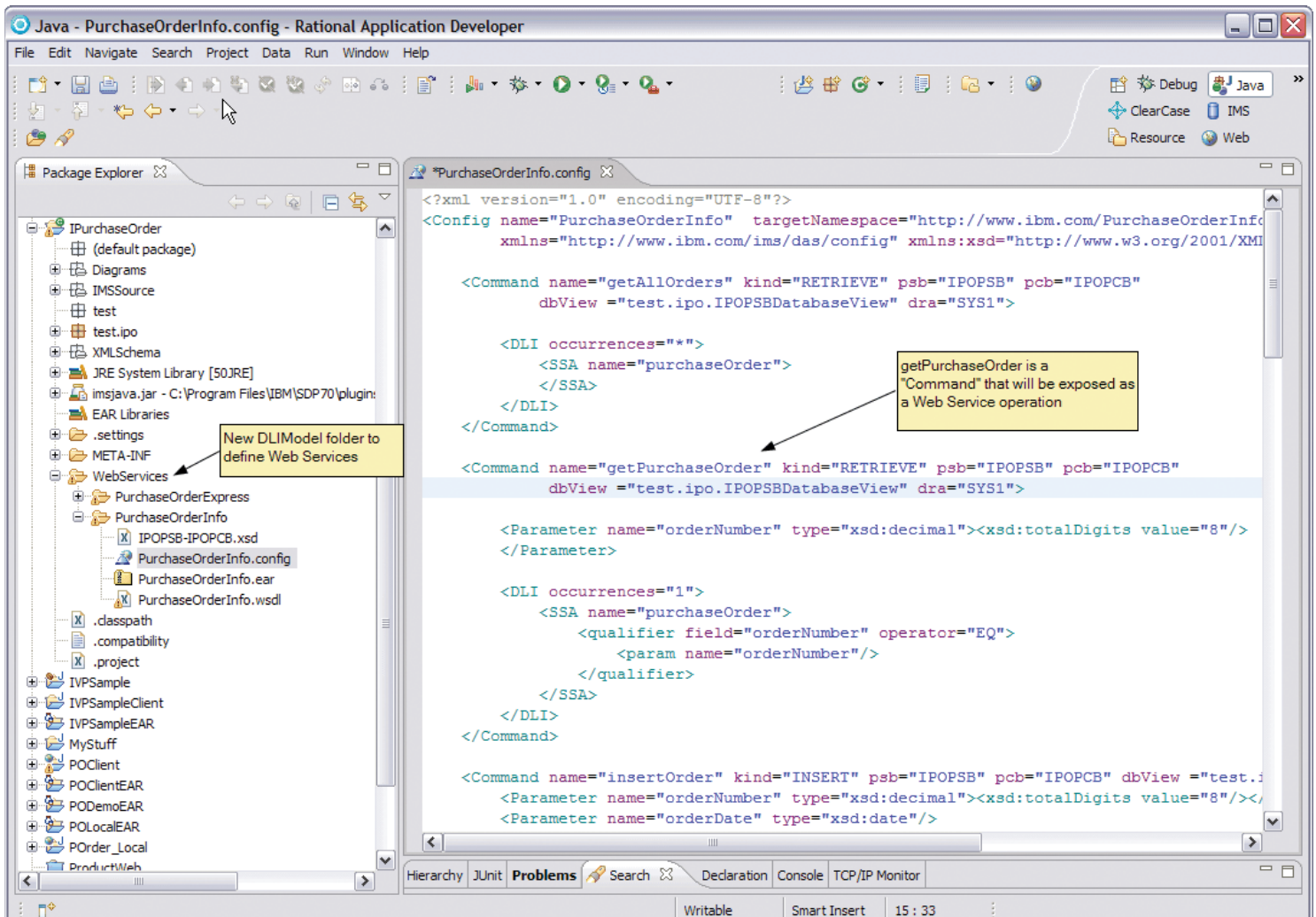

Figure 2

We provide a new library, IMSDAS (Data Access Service), which will convert each command from the configuration file into a corresponding DL/I call. It will access the IMS database using the Open Database Access (ODBA) interface. The XML Database component will convert the IMS data into XML, which will be returned as output in the SOAP message. The IMS DAS Enterprise Java Bean wraps the IMS DAS components into a deployable unit and provides an endpoint for SOAP requests. The current version of IMS DB Web Services is deployed on WebSphere Application Server for z/OS. Figure 3 illustrates the components that are part of the IMS DB Web Services solution.

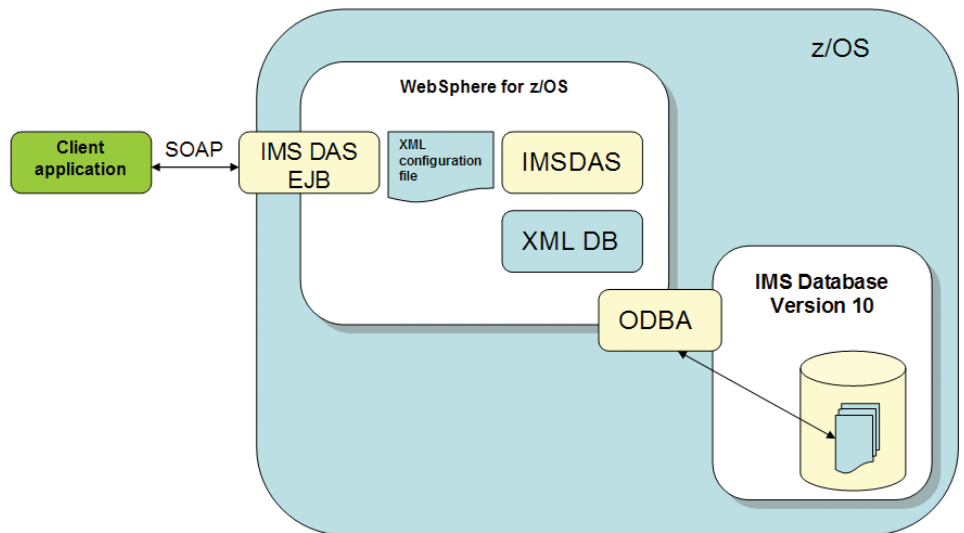
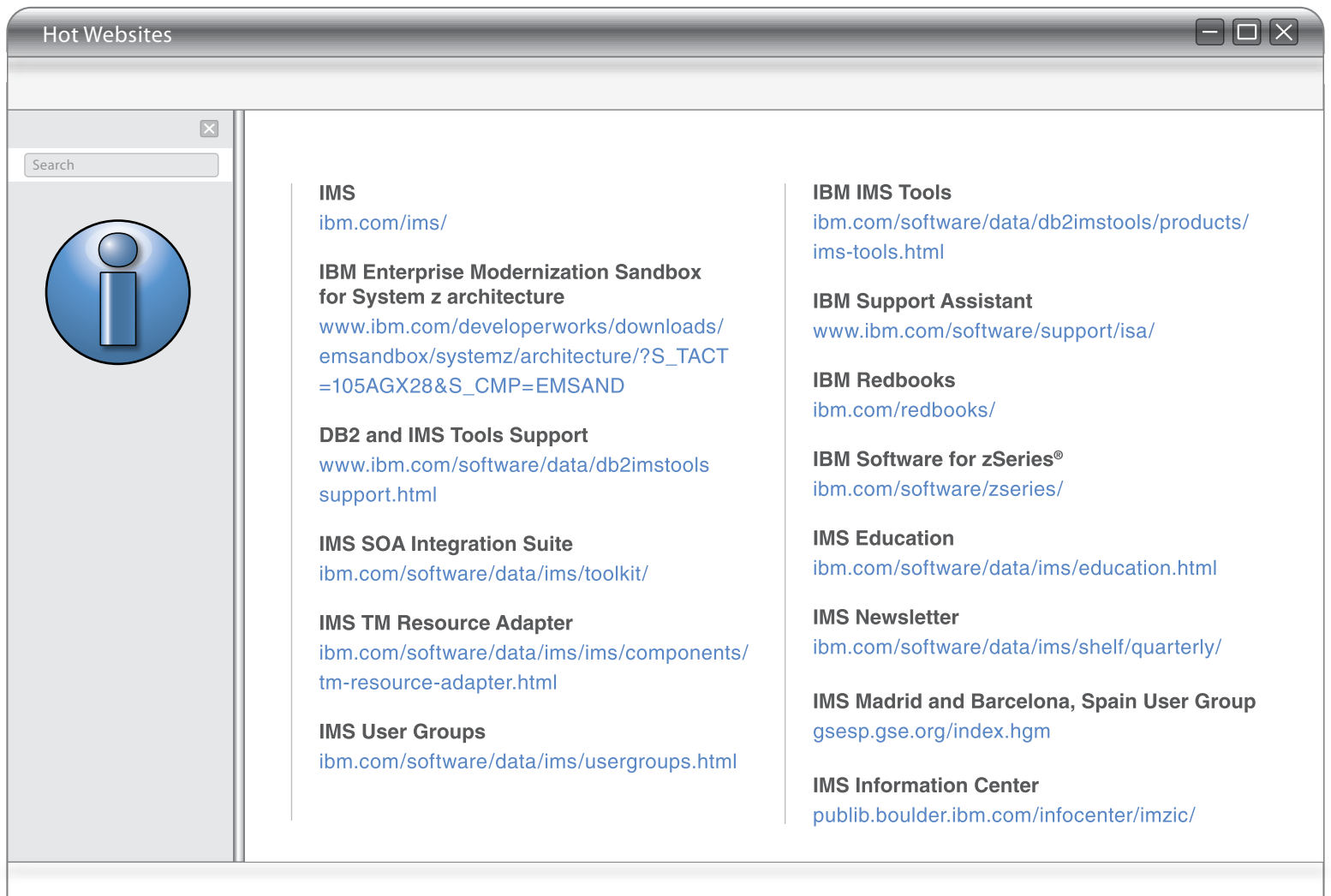

Figure 3

An SOA building block

The DLIModel tooling runs as a Rational Developer plug-in, thus allowing our clients



Hot Websites

Search



- IMS**
ibm.com/ims/
- IBM Enterprise Modernization Sandbox for System z architecture**
www.ibm.com/developerworks/downloads/emsandbox/systemz/architecture/?S_TACT=105AGX28&S_CMP=EMSAND
- DB2 and IMS Tools Support**
www.ibm.com/software/data/db2imstools/support.html
- IMS SOA Integration Suite**
ibm.com/software/data/ims/toolkit/
- IMS TM Resource Adapter**
ibm.com/software/data/ims/components/tm-resource-adapter.html
- IMS User Groups**
ibm.com/software/data/ims/usergroups.html
- IBM IMS Tools**
ibm.com/software/data/db2imstools/products/ims-tools.html
- IBM Support Assistant**
www.ibm.com/software/support/isa/
- IBM Redbooks**
ibm.com/redbooks/
- IBM Software for zSeries®**
ibm.com/software/zseries/
- IMS Education**
ibm.com/software/data/ims/education.html
- IMS Newsletter**
ibm.com/software/data/ims/shelf/quarterly/
- IMS Madrid and Barcelona, Spain User Group**
gsep.gse.org/index.hgm
- IMS Information Center**
publib.boulder.ibm.com/infocenter/imzic/

to benefit from an existing rich development environment in which they can easily develop and test IMS DB Web Services. We integrate seamlessly with other new IBM solutions, such as the IBM Mashup Hub. IMS DB Web Services is also an application building block, enabling our clients to build other solutions on top of it.

Our clients are looking to SOA to transform their business logic. IMS DB Web Services offers an easy way for clients to access their IMS data, reuse it in an SOA business model, or make it available using a web browser anywhere their business needs to run. IMS DB Web Services is one key that unlocks IMS data for reuse in an SOA business model. Modernizing IMS makes sense!

IMS Database Web Services is available with IMS Version 10 and requires the DLI-

Model utility Version 2.0.2. For more information about IMS Database Web Services, see www.ibm.com/ims. 

IMS Newsletter Is Moving Online

Yes, you read that correctly. Coming in 2009, the IMS Newsletter will be moving to an online delivery format as part of the IBM Information Management Worldwide subscription newsletter. We will have perhaps 2 more editions in hardcopy, so it's important to take steps now to ensure that you continue receiving up-to-date information about IMS! Simply link to www.bulldogsolutions.net/IBMims/IBN05282008/frmRegistration.aspx and complete the registration process. We look forward to continuing to provide you with the best information that IMS has to offer!

IMS Newsletter Team

IMS Tools Software Support – Yesterday and Today

Andrew Bullinger IMS Data Management Tools Level 2 Support

Do you remember when you spent hours on the phone with a Level 2 representative, presenting them—digit-by-digit—with the contents of your ABEND registers, control blocks, and storage areas? This was in lieu of shipping a dump to IBM and waiting a week for it to arrive and be evaluated. Thankfully those days are gone forever! Technology advances are greatly responsible for helping you save time, not to mention reams of paper.

With the help of web applications that enable remote viewing, and with FTP capabilities, we can focus on customers, and not process, when it comes to customer support. We can review your documentation and determine whether the issue is known or not.

Here are some basic Software Support tips to help you save time and expedite problem resolution:

1. Use Self Assist before contacting us

Start by visiting the DB2 and IMS Tools Support Web site:
www.ibm.com/software/data/db2imstools/support.html.

From the **Download** link, you can link to PTF Listing and Ordering, where you can view current IMS Tools maintenance and download appropriate PTFs.

From the **Troubleshoot** link, you can find the latest troubleshooting information and links to resources to help you diagnose and resolve any IMS Tools issues.

Using the **Search** link, you can search within Technotes, FAQs, flashes, forums, APARs, manuals, Redbooks, white papers, education, and newsletters.

Using the **Documentation** link, you can browse our library to find information about IMS Tools products and find answers to your questions.

Using the **Plan** link, you can find new product releases, enhancements, and product life cycles that match your company's unique requirements.

From the **Use** link, you can find usage tips, best practices, and links to other easy-to-use web-based tools.

You can also access **Open service request**, which provides links to web-based tools such as IBMLINK for reporting IMS Tools problems to IBM Support.

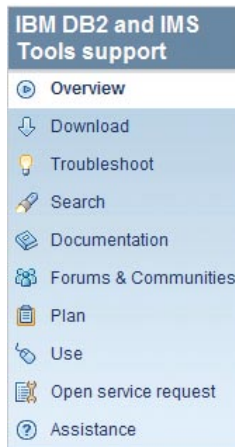

2. If you need to contact the support center, follow these preparatory steps

Define the problem.

Gather background information.

Gather relevant diagnostic information.

Determine the severity level.

If you are unsure about what documentation is required, check out IBM Support Assistant (ISA) Version 3 (www.ibm.com/software/support/isa/). Search on MustGather and the product for which you require assistance. To contact our support center, see www.ibm.com/planetwide/ for contact information that is based on your geographic area. To electronically submit problem reports through IBMLINK, see www-304.ibm.com/usrsrvcc/account/userservices/jsp/login.jsp?persistPage=true. You will be asked to register with your IBM ID and password.

3. Use FTP to send documentation to the IMS Tools team

You can send your documentation to the IBM FTP test case server at TESTCASE.Boulder.IBM.COM.

USER: anonymous

PASSWORD: your complete e-mail address

Place your file on the /toibm/im directory by using the PUT command for IMS Tools and DB2 Tools. After the transfer is complete, provide the following information in your ETR:

File names—Prefix with your PMR number, for example, ETR09165.LOG.

MVS™ data set attributes including LRECL, RECFM, BLKSIZE, and space.

Be sure to terse SVC dumps, PDSs, and log tapes (OLDS) by using TRSMMAIN. Files must be sent RECFM FB. If you do not have TRSMMAIN, you can get it here: ftp.software.ibm.com/s390/mvs/tools/packlib/.

4. Our response objectives are based on severity

Distributed platform response objectives:

S1—Critical business impact—Within two hours

S2—Significant business impact—Within two business hours

S3—Some business impact—Within two business hours

S4—Minimal business impact—Within two business hours

System z platform response objectives:

S1—Critical business impact—Within two hours

S2—Significant business impact—Within four business hours

Severity 1	Critical situation/system down. Business-critical software component is/are unable to register a call inoperable. Critical interface has failed.
Severity 2	Severe Impact: A software component is severely restricted in its use, causing significant business impact.
Severity 3	Moderate impact: A non-critical software component is malfunctioning, causing moderate business impact.
Severity 4	Minimal impact: A non-critical software component is malfunctioning, causing minimal impact, or a non-technical request is made.

S3—Some business impact—By the end of next business day

S4—Minimal business impact—By the end of next business day

Now that the future is here, be sure to save your valuable time and take advantage of these tips. We do understand that when you run into a problem, you want to have it diagnosed and resolved as quickly and as painlessly as possible. These tips will help make your IMS Tools support experience a positive one.

Complete Software Support details can be found in IBM's Software Support Handbook located at:

www14.software.ibm.com/webapp/set2/sas/f/handbook/home.html. 

Jump Start Your IMS Education

Are you considered the IMS expert in your organization? Or are you new to the world of Fast Path, shared queues, DBRC, HALDB, and IMS SOA? Wherever you happen to be on the spectrum of IMS knowledge, educational opportunities are available now to help you move further along that spectrum.

IBM provides over 30 unique IMS classes across several disciplines:

- Application programming
- Communications
- Database organization
- DBCTL
- DBRC and data sharing
- IMS fundamentals
- Installation
- Migration
- Security

Three training paths are available. Training paths help identify a sequence of classes that you can take to build your knowledge in a specific area of IMS. The courses that are offered in the IMS paths include:

These IMS classes are offered in traditional classroom settings; however, many are also available as instructor-led online classes, which give you the benefits of being in a classroom with the convenience and cost savings of online training. If your team is geographically dispersed, you can also request that instructor-led online courses be delivered privately for your company. Of course IBM can also deliver a traditional IMS classroom course privately as well, either at your company location or at an IBM facility.

Are you located in Europe, the Middle East, or Africa? If so, you may have been getting IMS education from the International Mainframe Software Society (IMS-Society). However, IBM EMEA is taking back responsibility for IMS education from IMS-Society. We are also pleased to report that a full set of IMS courses will be offered in India in 2009! Be sure to visit www.ibm.com/software/data/ims/education.html to get the most current news about these ongoing changes.

We have one final bit of good news to share with you. There has been much focus in recent years on growing the next generation of IMS experts. To that end, we are happy to report that Marist College in Poughkeepsie, New York has committed to delivering IMS education as part of its z/OS coursework starting in the Spring of 2009. We are pursuing other educational opportunities at universities in the United States, in EMEA, and in Asia

Pacific, and we will report on those in future editions of the IMS newsletter.

IMS Application Development	IMS Database Administration	IMS System Programming
<ul style="list-style-type: none"> › IMS DB Application Programming › IMS DC Application Programming › IMS Connectivity and Web Enablement Workshop 	<ul style="list-style-type: none"> › IMS DBRC and Data Sharing › IMS Database Performance and Tuning › IMS High Availability Large Database › IMS Data Sharing › IMS Fast Path Implementation 	<ul style="list-style-type: none"> › IMS System Programming: DBCTL › IMS System Programming: DB and TM › IMS DBRC and Data Sharing › IMS Data Sharing › IMS Shared Queues › IMS Parallel Sysplex Workshop › IMS High Availability Large Database › Implementing IMS Security › IMS Database Performance and Tuning › IMS Transaction Manager Performance and Tuning › IMS Diagnostic Approaches

Start the New Year with a resolution to acquire, grow, and optimize your IMS skills. Visit www.ibm.com/software/data/ims/education.html to get started!

I enjoyed this course very much. Our instructor was professional, competent and enthusiastic in conveying the material. He presents complex information in a simple, user-friendly manner. ~ Michael H.

Very good class! The class had all types of skill sets and the instructor was able to communicate to each of us on our own level. ~ David S.

Just a superb training experience. The teacher knew the material extremely well, could handle conceptual and detail-level questions equally well, spoke to all roles (admin and developers), and had relevant experience working with customers.

~ Christy D. 

Meet the professionals who design, develop, build, and support IMS!



Kin Lau

Kin Lau

For Kin Lau, who is part of the IMS Reliability and Serviceability (RAS) team, everything is connected. After a summer internship with IBM Rochester (Minnesota), Kin moved to the west coast to pursue a Master's Degree in Computer Science from Stanford. IBM Silicon Valley Lab beckoned, so Kin began to split his time between Stanford and SVL. Kin completed his degree and began to establish new roots. Of his role on the RAS team, Kin says that he appreciates "being able to impact many different areas of IMS; I get a better breadth of understanding." Kin has contributed to the IMS Abend Search and Notification tool, BPE External Trace, and the IMS plug-in for IBM Support Assistant. Kin also volunteers as an advocate in the IMS Education team. "The people in IMS are genuinely helpful," says Kin. "That is a big plus." Outside of his work on the RAS team, Kin devotes his attention primarily to music. He began taking piano and singing lessons as an adult and spends a lot of time practicing both. Kin is quick to point out the symbiotic nature of his role in the IMS organization and his musical pastimes. "Everything is definitely connected. Both sides of me require discipline to move forward, a certain willingness and creativity to get something accomplished." That forward movement includes a new IMS project in a very different area of IMS. Kin looks forward to the leadership opportunity and gaining more perspective of IMS.

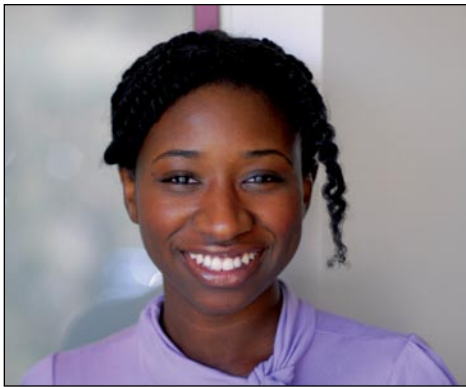

Malaika Paquiot-Mose

Malaika Paquiot-Mose

Malaika Paquiot-Mose joined IBM in March of 2003 after completing her Master's degree in Engineering at Tennessee State University. She joined the IMS On Demand team, where her attentions were primarily focused on IMS TM Resource Adapter. After getting a sense of the length and breadth of IBM, however, Malaika wanted a closer look, so she accepted a 6-month assignment in Somers, New York, to get a better sense of how IBM works at a higher level. She helped to evangelize some of IBM's collaborative development environments, including ThinkPlace and BizTech. She met with several IBM executives, including Tom Rosamilia, Al Zollar, Jeannette Horan, Beth Smith, and many others, to build her own knowledge base before returning to IMS On Demand. Malaika says of her IMS colleagues, "everyone is very supportive and friendly; it's a nice work environment." She added that "there is a strong sense of loyalty" in IMS that resonates with her. Clearly, Malaika carries the same sense of loyalty, as she recently took on a new assignment as the Manager for IMS Systems 1. Outside of IBM, before becoming Mom to a 1-year old son, Malaika enjoyed salsa, arts, and researching the impact of technology on independent film making, but motherhood trumped all that!



Geoff Nicholls

Geoff Nicholls

Geoff Nicholls is an IMS Technical Advocate in Melbourne, Australia. That's his home base, but his footprints have been all over the world in support of IMS. Geoff has been a part of the IMS team for 19 years, initially working with the ANZ Bank as an IMS Specialist, and for several insurance companies as a DBA. Geoff defines his responsibilities as "whatever it takes to make IMS successful." That means on any given day, Geoff might be consulting with customers, debugging, delivering manuals, creating strategies for education, or just having a cup of coffee with customers to find out what they are doing. "The team has always been a great, personable team to work with," says Geoff. People who work with and on IMS have "a way of helping each other out—it's cooperative rather than competitive." Geoff's focus has always been on Database and Application Development. "For a product that is 40 years old, IMS is still ground-breaking," says Geoff. "It is still generating patents to this day." Outside of his role as an IMS Technical Advocate, Geoff devotes himself to home and hearth. He and his wife are very involved with the activities of their four children: one son is studying classical music for the double bass, another son plays basketball, another son is painting these days, and his daughter plays the tuba! 

IMS Newsletter

Volume 0803

Editor-In-Chief Sandy Sherrill
Graphics & Layout Editor Crystal Glasgow
Content Development Editor Maria Querales

Or contact us in any of the following ways:

Email: imsmkt@us.ibm.com
Fax: (408) 463-4101
US Mail: IMS Newsletter
IBM Corporation
555 Bailey Avenue
X94A/A249
San Jose, CA 95141-1003

© International Business Machines Corporation
Printed in the U.S.A. 11/08
All Rights Reserved

DB2, IBM, IMS, MQSeries, MVS, Rational, System z, WebSphere, z/OS, and zSeries are trademarks or registered trademarks of International Business Machines Corporation in the United States, other countries, or both.

Java and all Java-based trademarks and logos are trademarks or registered trademarks of Sun Microsystems, Inc. in the United States and other countries.

Windows is a trademarks of Microsoft Corporation in the United States, other countries, or both.

Other company, product, and service names may be trademarks or service marks of others.

The information in this document concerning non-IBM products was obtained from the suppliers of those products or from their published announcements. IBM has not tested those products and cannot confirm the accuracy of the performance, compatibility, or any other claims related to non-IBM products.

Questions on the capabilities of non-IBM products should be addressed to the suppliers of those products.

IMS Newsletter
IBM Corporation
555 Bailey Avenue
X94A/A249
San Jose, CA 95141-1003

Editorial

Sandy Sherrill

What's an IRUG? It's an IMS Regional User Group! 2008 was an exciting year for us, because we successfully launched the IMS Regional User Group meetings.

IMS customers, vendors, and IBM support personnel came together in Glendale (LA), Phoenix, Detroit, Columbus, New York, and Toronto to discuss how best to generate the momentum to create a thriving IMS user group community. Topics were presented on IMS Performance, Security, Disaster Recovery, Version 11, and more. Customers confirmed that they were eager to have an opportunity to meet with peer IMS professionals and find ways to help one another maximize their investment in IMS and IMS-related products. With Round 1 completed, plans for Round 2 are now underway! More information will be posted to the IMS Web site as dates are set. If you have questions that can't wait, send them to ssherill@us.ibm.com. 



**The Glendale, California
IMS regional user group
takes a break**

IMS 40th birthday celebration

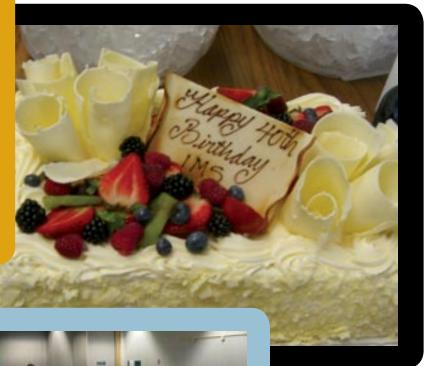

**IMS regional
user group
meeting
Toronto, Ontario,
October 24**