



e-business

e-business powered by IMS



the world depends on it

IMS: Powering the 21st Century

IBM

At the brink of the new century, IMS is still leading the way. More than 30 years since the first IMS-ready message from the Apollo Space program, IMS and the S/390 are breaking technology barriers, but sometimes taken for granted. Information technology has significantly changed to address the changing world of business. Market forces have been changing the way we do business. Regulation, economics, have been changing as businesses become more global. Growth of the Internet, the global reach, the new commerce channels are changing the way everybody does business, like the upswing in mergers and acquisitions. Views into information are becoming as important as the information itself. Amalgamation and aggregation is becoming widespread in the industry. Businesses are exploiting new technologies to enable new customers with new information across the web, in a global day. Businesses are being challenged with balancing priorities and need new ways to gain and retain competitive edge to address increasing demands and sophistication of their customers. IMS customers are at the bleeding edge of this reality. Yet at its heart, business stays the same. Industry forces are making the highest demands for performance and availability, along with interoperability, flexibility, and support for new, emerging technologies. This is something IMS people have been hearing for years. And IMS continues to help efficiently provide heterogeneous access across global networks and in addressing companies' changing needs. IMS is now providing integrated solutions with IMS to help our customers further.

This will cover the IMS strategy, recent announcements for IMS and the S/390 environment in which it runs, and future directions for IMS in powering the 21st century.



e-business

Open Software Leadership

1998 US Database Patents

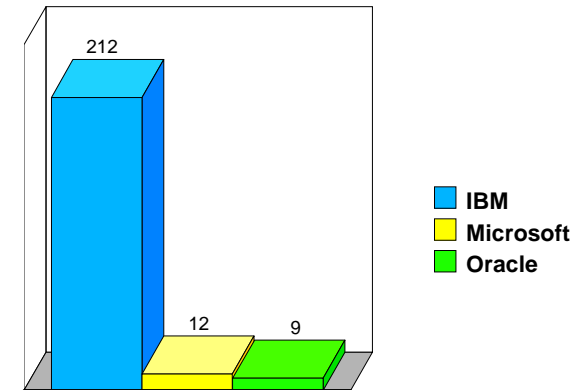

- **Key Technology**
- **Enterprise Solutions**
- **Information Mining for Personalization**
- **Using All of IBM's "arms and legs"**
 - Solutions, Services, Classes, Benchmarks
 - Services Engagements from Labs Directly
 - Design Center for e-transaction Processing

IBM

IBM is focusing on a set of objectives which include IMS to provide strength for parallel and distributed environments with open software leadership. Data and Transaction Management are key to delivering collaborative software, providing access and management technologies and integrating systems management tools. IMS is providing the leading edge strength in this area. IMS was first to exploit parallel and distributed environments. New IMS patents in the past year have well exceeded the combined total of our nearest competitors.

Open solutions, being provided across the enterprise are developed for end-to end, mixed-tier environments, exploiting the individual system features and differentiators, integrating mixed environments with middleware, improving systems management, and delivering connectivity and interoperability with Java, Component Broker, and WebSphere tools for IMS. All of this is being enabled in conjunction with other systems our customers are using.

Personalization and growth are critical to remaining competitive. IBM provides broader, high performance access to existing IMS applications/data, and personalization of this information with tools for gathering, analyzing, filtering and presenting in new ways through information mining technologies.

IBM offers guidance with solutions and services through IBM Global Services, Education and Training, Systems Centers, and service engagements from our laboratories directly. IMS specialists from Dallas systems enter and Santa Teresa Laboratory are available to help offer you additional consultation and services.

A new design center, located in Poughkeepsie, NY, has been set up to work with customers to design and build integrated e-Commerce solutions ad end-to-end application prototyping. All IBM platforms and many non-IBM ones will participate in the center. IBM skills in Research, Software, Services, Networking will support customers worldwide,

e-business Transforming Key Business Processes With Internet Technologies



e-business

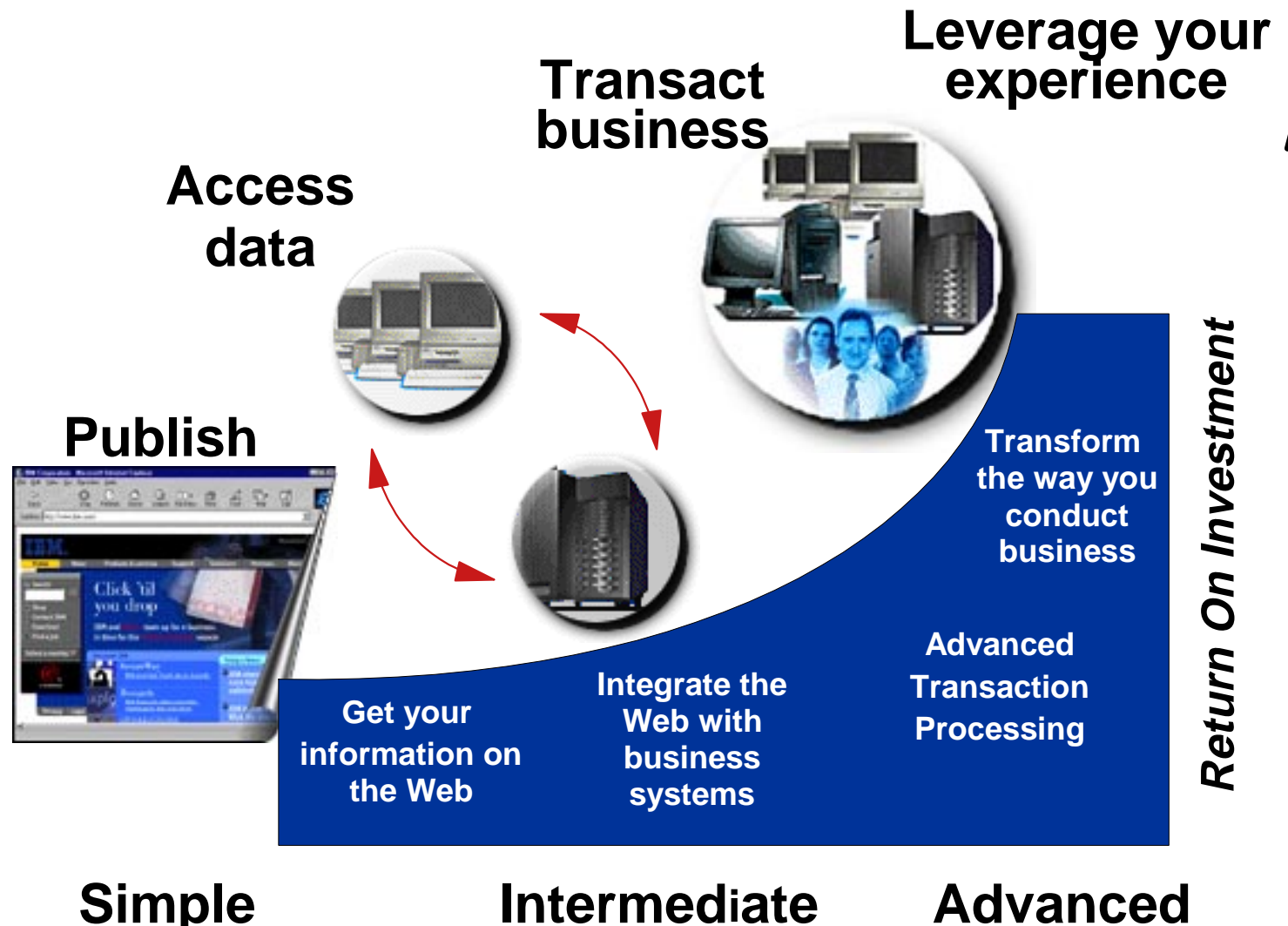

The future is in creating/expanding new-existing information out to wider networks of people, economically. Customer's needs must be addressed, new technologies exploited, application concerns handled. We need to help you ensure simplicity, maintain security, maximize your skills, while optimizing your company's return on investment.

e-business is no longer simply about static web pages -- it's about putting your entire business on the internet, integrating new applications with existing transaction systems to handle the explosive growth of the Internet economy. It's a place where customers, suppliers, and business can come together securely, anywhere, any time.

e-transaction processing is about the evolution of e-business. Extreme Information Technology needs for e-transaction processing are scalability, non-disruptive capacity upgrades, availability, security, flexibility, high bandwidth, balanced systems with the ability to handle mixed workloads and system and storage management. Advanced Transaction processing calls for continuous up time for applications, high levels of security, end-to-end business transaction integrity, real time data currency, and management of unpredictable volumes.

IMS and S/390 Solutions Enabling e-transaction Processing



e-business

Your Needs...

Flexibility to handle unpredictable volumes

Continuous up time for applications

High Levels of Security

End-to-End Transaction Integrity

Real Time Data Currency

IMS and S/390 Deliver...

Workload Manager links business priorities with transactions

Parallel Sysplex is designed for continuous computing

Security has always been a design point

Parallel Sysplex Coupling Facility manages locking across multiple servers

A single instance of data is shared across all applications in a Parallel Sysplex environment



In the new world of e-transaction processing, S/390 and IMS can uniquely integrate new applications with existing data to harness the global opportunity of enterprise-critical e-business. IMS meets extreme Information Technology needs for e-transaction processing.

IMS and the S/390 have been delivering on the promise of e-business and continue to do so with new enhancements for e-transaction processing bandwidths capable of supporting the largest web sites and transaction rates through GB ethernet, Fiber connection technology and industry leading webserving with the IBM WebSphere Application Server Enterprise Edition, and SecureWay Communications Server for OS/390. A balanced system is provided for world class solutions with the S/390 Workload manager, Tivoli manager for OS/390 and the new OS/390 InfoPrint -- the first server to print through Internet protocols. IMS together with the S/390 are delivering more comprehensive security protection, featuring centralized management and a strong suite of end-to-end products. We continue to provide and enhance our leading edge end-to-end transaction integrity and real time data currency with the sharing of data, networks, and messages, utilizing the sysplex and its Coupling Facility.

Our technology transition from bipolar to CMOS allowed us to deliver improving price/performance to our customers. That improvement approaches a factor of 100 over the last 120 years. In 2Q, S/390 MIPS shipment grew 118 percent, marking the 4th consecutive quarter of better than 60 percent MIPS growth. Customer surveys indicate that about 1/3 of this year's MIPS volumes will be used for new workloads, like e-business related applications.



e-business

IBM Storage Area Networks



- Providing dedicated, centrally managed, secure information infrastructure
- Enabling any-to-any interconnection of servers and storage systems
- Enterprise Storage Server: The new Standard
 - Breakthrough Performance
 - Comprehensive Availability
 - Extensive Connectivity
 - Heterogeneous attachments - any server to any storage
 - Multiple protocols (FICON, SCSI, ...)
 - Low Total Cost of Ownership

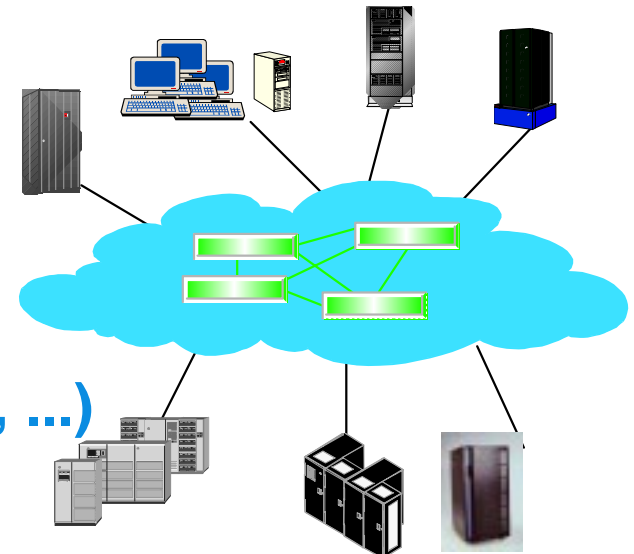

*Emerging Fibre Channel
Technology*

IBM

Customers also face challenges in managing storage. Then need to facilitate enterprise-level universal access and sharing of resources, support unpredictable explosive information technology growth, provide affordable 24X365 availability, simplify and centralize storage resource management, improve information protection and disaster tolerance, and enhance security and data integrity of new computing architectures. A Storage Area Network (SAN) is a dedicated centrally managed, secure information infrastructure, which enables any-to-any interconnection of servers and storage systems. Over a 30-year evolution, SANs are now rapidly being extended and integrated into enterprise-wide distributed network environments using Fiber Channel Technology.

The IBM Enterprise Storage Server is a new generation of enterprise disk storage systems designed to provide world class performance, scalability, and universal access to data across all enterprise computing environments. ESS provides extensive scalability with capacity configurations ranging from 420 GB to 11.2TB. Breakthrough performance is made possible by a powerful storage architecture, SSA disks and in special synergy with S/390 storage. Comprehensive availability is there with no single points of failure or repair. The ESS Remote Copy function improves availability by mirroring the data in a remote location, thereby providing availability should a disaster occur. With FlashCopy you can have a guaranteed point-in-time copy of your data in 2-5 seconds. The ESS connects to all the major channel types including ESCON, Ultra SCSI, FICON, and FC/AL; plus all major server types such as S/390, UNIX, Intel-based servers, and the AS/400. The ESS can attach to fibre today via the IBM SAN data gateway. The ESS will provide the lowest total cost of ownership due to its low initial acquisition cost, field upgrade capability, and the ESS specialist storage management software.



e-business

Supporting e-business Transformation

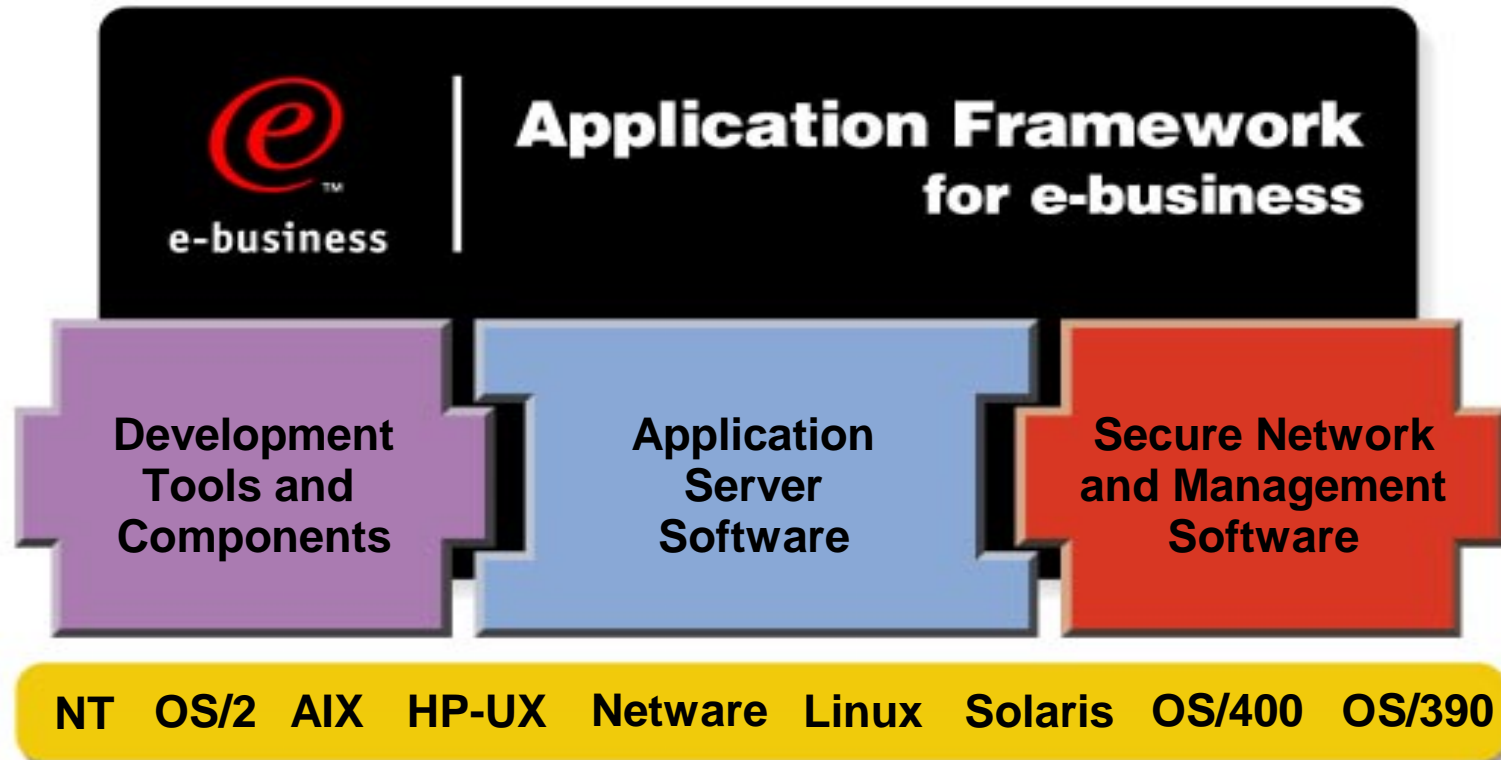

- **Extend Existing Applications into the world of e-business**
- **Rich Capabilities to support simple-to-sophisticated applications**
- **Rapid Application Development environment based on Cross-Platform Standards, including Java**
- **Systems Managed for 24X7/365/Hundreds of Millions**

IBM

Key to all of this is:

Cross-platform distributed middleware for access to your existing and new IMS applications and data.

An application development environment that brings things together and offers consistency. WebSphere and Java can provide the development tools and run time application server environments across platforms.

Integrated end-to-end systems management capability to manage networks applications and databases and all the other things that customers run in their environment. Tivoli can provide the systems management.

And of course IMS is providing Transaction and Database integration for this. We are focusing for IMS on all the parts and their integration, in particular on the integration of products, of applications, and the development and runtime tools used with them, and of the operational environment.



IMS Runs the World...



■ Most Corporate Data is Managed by IMS

- Over 90% of Fortune 1000 Companies use IMS
- IMS Manages over 15 Billion GBs of Production Data
- \$2 Trillion/day transferred thru IMS by one customer

■ About 50 Billion Transactions a Day run through IMS

- IMS Serves Close to 150 Million Users a Day
- 64.6 Million IMS Trans/Day Handled by One Customer on a Single Sysplex
- 120M IMS Trans/day, 7M per hour handled by one customer
- 670K/sec (60 Million/day) across TCP/IP to a single IMS

■ Ninth Largest Revenue Producing "Software Company"

"A still large and loyal IMS installed base due to the rock solid reputation of a transactional power horse for very large workloads. IMS is already successfully proven in large, web-based applications."

- Gartner Group Report, Sept. 10, 1998.

The IBM logo, consisting of the letters 'IBM' in a bold, sans-serif font.

Industries world-wide rely on IMS to run their businesses. IMS is part of everyday life. Chances are you are using IMS when you turn on a light, make a telephone call, get a business loan, process accounting records, use your ATM card, put money in a bank, rent a car, purchase insurance, travel, send a package, track in-transit packages, trade stocks, control inventories, process payroll, update personnel records, control an assembly line, control a railroad, use corporate database, run a government agency, conduct international business/banking, and many more.

More than ninety-percent of the Fortune 1000 companies use IMS. IMS serves 150 million end users, managing about 15 billion Gigabytes of production data and processing about 50 billion transactions every day. IMS still owns the high-volume on-line transaction and database management environment. IMS customers have been driving their own growth with IMS. 64.6 million transactions were handled by one customer in a single 1998 day on a single sysplex system. 7 million Transactions/ hour and 120 million transactions/day were handled by another customer. IMS in-house testing reached 670 transactions/sec (nearly 60 million/day) across TCP/IP to a single IMS on a single machine (9672RX5).

IMS, IBM's premier hierarchical transaction and database management system, is the product of choice for critical on-line operational applications and data where support for high availability, performance, capacity, integrity, and low cost are key factors. Today, IMS manages the world's mission-critical data and has been at the forefront of the swing back to mainframe usage.

From a Gartner Group Research Report "A still large and loyal IMS installed base due to the rock solid reputation of a transactional power horse for very large workloads. IMS is already successfully proven in large web-based applications."

Migrating Forward - the IMS Customer Base



e-business

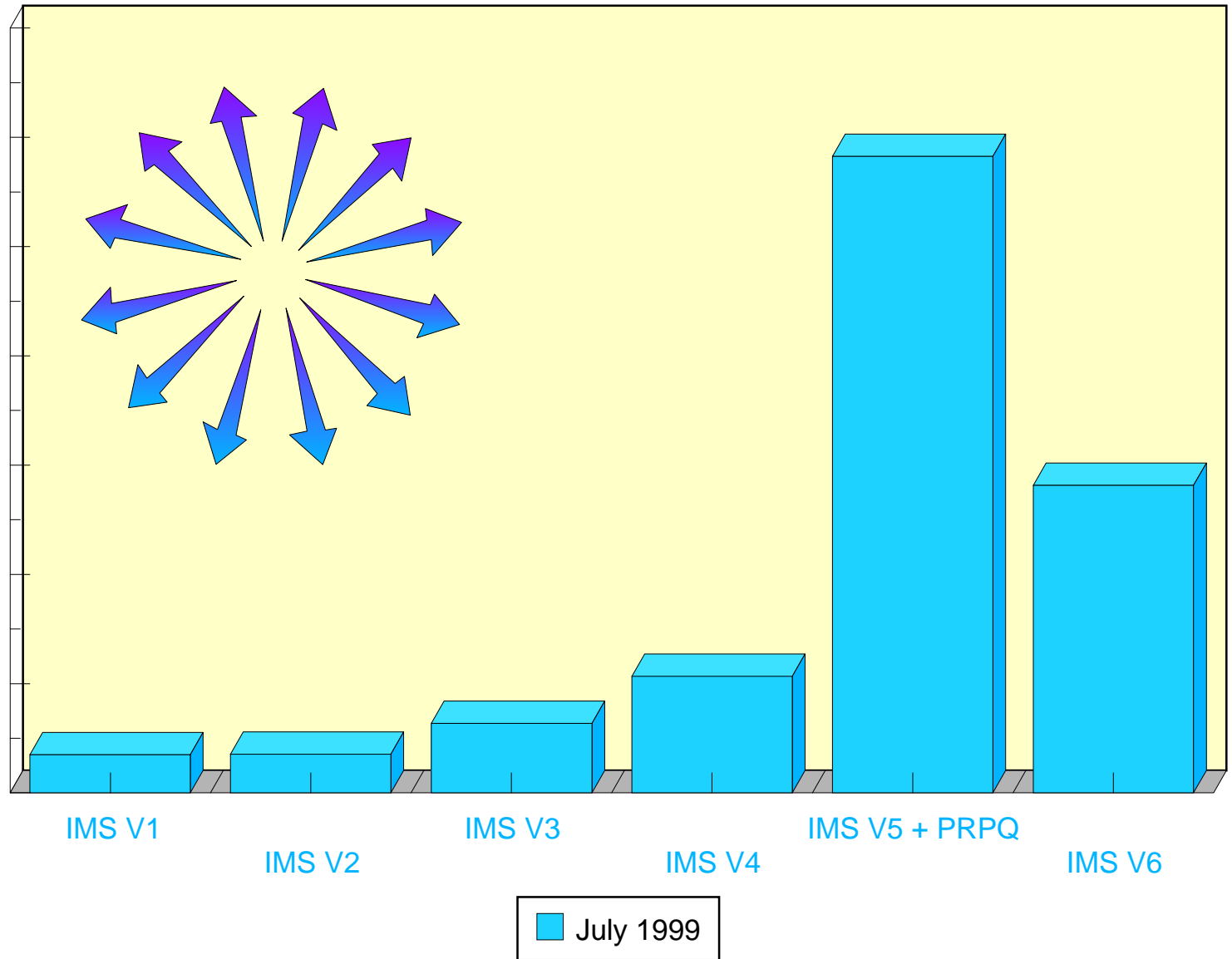

IMS License Distribution



As IMS has been making major improvements to quality, installability, and usability, new versions are becoming easier to install and use. IMS customers have been moving rapidly forward to take advantage of newer technology provided with the more recent versions of IMS. IMS Version 5 proved to be the fastest growing version in IMS history. The newest IMS, Version 6, with significantly more function than any earlier versions, now appears to be exceeding that rate of install. IMS licenses have been growing and revenue this year has exceeded expectations with double digit growth year to year.



IMS is Providing e-business Solutions

- **Parallel Sysplex** Network, Message, and Data Sharing
- **Systems Management** Function and Tools
- **Open Access** to IMS Transactions and Data
- **Java** Application Development Tools

Continuous Availability

Systems Mgmt/Usability



High Performance/Capacity/Scalability

e-business Enablement

Strategic, Open Access, S/390 Enterprise Serve



The IMS Transaction and Database Server for S/390 is evolving to further strengthen its support for Enterprise and Network Computing environments. IMS has been providing increased capacity and incremental horizontal growth and offering improved availability with network, message and data sharing, utilizing the coupling facilities of the S/390 and the latest technological advancements for security and integrity of OS/390.

IMS has also been providing improved systems management in automated operations, workload balancing, dynamic routing, dump analysis and packaging enhancements. Building on a tradition of success, IBM has been offering additional product and tools for IMS which enhance enterprise computing systems management, availability, and capacity (for example, with the new Sysplex Recovery coordination, and High Performance DB tools).

IBM is also offering additional product and tools enhancements for Network Computing to simplify access to both legacy and new IMS applications and data. IMS V5 introduced the IMS Open Transaction Manager Access facility for better integration and efficient access of IMS by other S/390 subsystems, such as MQSeries, TCP/IP, and DCE/RPC.

IMS has been rolling out solutions for the e-business IBM Connectors. These consist of common cross-product solutions, such as IMS Connector for Java, and MQSeries Connector for Lotus Notes with IMS, and for common internet access to IMS and CICS applications. IMS Connectors provide IMS solutions for network, internet, and object connectivity, and utilize the latest technology offered for the Web, Java, and Component Broker. IMS has been enabled for the 21st century and the Internet and as a result continues to grow.



e-business

IMS in a Parallel Sysplex

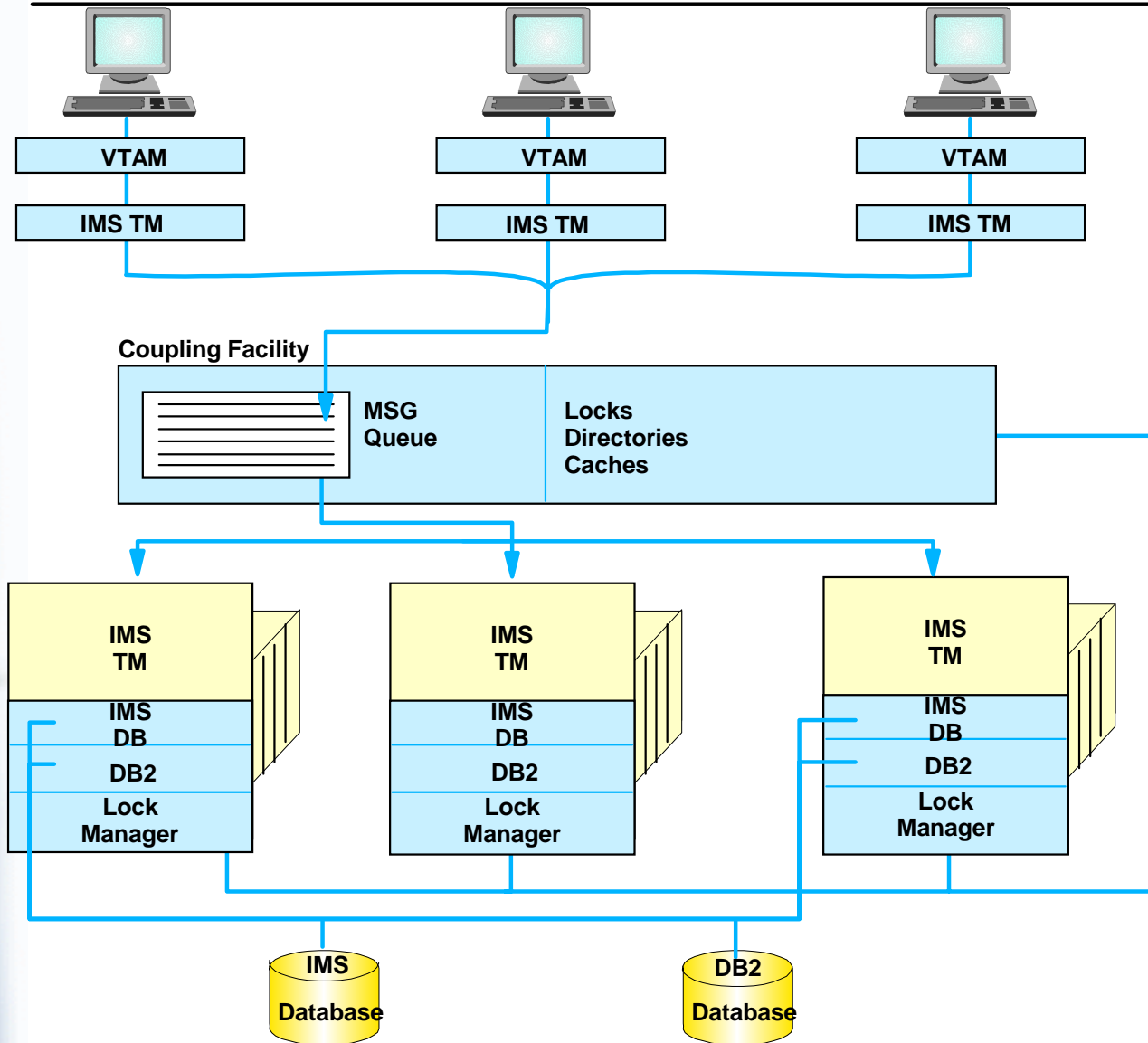

Allocation of workstations

Dynamic Workload Balancing

Data Sharing
▸ IMS DB
▸ DB2

Easier access and management of enterprise applications and data



IMS continues to strengthen its support of the enterprise by providing the highest in performance, availability, security, integrity, at the least cost per transaction. In doing this it has been exploiting the hardware/software environments that it has grown up along side of. IMS fully exploits for customer advantage the new technology and power of OS/390 and the Parallel Sysplex.

Existing IMS data sharing capability was enhanced with IMS Version 5 to take advantage of the coupling facility for storing lock information and for easy availability of that information by all systems in the Sysplex environment. The lock manager in each system could access the locks as they needed to. In addition to data sharing, IMS V5 provided necessary information to the MVS workload manager to assist with workload balancing of resources across the Sysplex. IMS also enhanced message routing between systems to take advantage of workload balancing information, and IBM provided the IMS Workload Router to use these facilities to push the work to the available system. IMS V5 also provided Remote Site Recovery, which allowed backing up an IMS system with another at a different location. A database at another system is maintained to match the primary database and/or a log is maintained that can dynamically and quickly update that remote data base to allow takeover in the event of failure.

Significant enhancements for IMS V6 are being added to those provided in IMS V5 to complement the Parallel Sysplex hardware and operating systems facilities. IMS V6 improves the IMS V5 Data Sharing and Workload manager enhancements with additional data sharing (storing changes and unaltered data on the coupling facility for Sysplex access, and providing additional Fast Path sharing), message sharing (providing message queues and fast path messages on the coupling facility for Sysplex access), and message routing enhancements (utilizing VTAM Generic resource support). As customer workload grows, the power that distributing data and applications across the Sysplex provides is needed. End users want to be able to access applications and data transparently, regardless where the work is processing. This enhanced support provides improved end user interaction, improved IMS availability, improved workload balancing, and offers increased capacity and growth in moving into Parallel Sysplex environments.

IMS's Fast Path capability continues to be enhanced to provide the fastest access through the system, continuing to lead database products. Against industry standard benchmarks it continues to show as the best price performance at the lowest cost, confirming that nothing in the transaction market matched the speed and power of the IBM S/390 with IMS.



e-business

IMS Version 6

Availability

- Daylight Savings Time
- FP DEDB Online Change
- Fast DB Recovery
- Online Storage Reclaim
- ETO Automatic Logoff/Signon Timeout

Systems Management

- VTAM Generic Resources
- Date Beyond 1999 Expanded Year Format
- DFSMS Concurrent Copy
- Dump Analysis and Evaluation Aids in Problem Diagnosis
- Generic Start Region
- Sysplex Communications
- Sysgen Improvements
 - ▶ Eliminate Conditional Assemblies
- Packaging
 - ▶ Reduce Installable Entities and Separate Features

Performance/Capacity

- 8 GB DB Support
- UCB/VSCR
- >255 SID's
- Sysplex Sharing Innovations
 - ▶ Queues
 - ▶ Data Caching
 - ▶ SDEP's
 - ▶ VSO
 - ▶ EMH
- DBRC Performance/Parallelism with Recon I/O
- DBCTL Single Cycle Commit

Network Computing

- Distributed Synchpoint
- WWW Connection
- APPC Security use of System Authorization Facility
- Message Retrieval for Absent Applications

The IBM logo, consisting of the letters 'IBM' in a bold, sans-serif font, with horizontal lines through the letters. It is positioned at the bottom left of the slide.

IBM

IMS V6 availability enhancements also include Daylight Savings Time support, Online Change of Fast Path Data Entry Databases, Faster Database Recovery, Online Storage Reclaim, and the Extended Terminal Option Timeout. Systems Management enhancements include support for VTAM generic resources, Yr2000 4 digit date support, DFSMS Concurrent copy, problem diagnosis, generic start of regions, Sysplex communications, eliminating sysgen conditional assemblies and packaging enhancements, which reduce the number of installable entities and separate features. Performance/Capacity enhancements extend the size of the Databases, the Unit Control Blocks (UCBs) into virtual storage and the number of System Identifiers, and improve performance of IMS Data Base Recovery Control (DBCTL) facility, DBCTL commit and data sharing. Network Computing enhancements include Distributed two-phase commit, Internet connectivity, APPC security, and message retrieval for absent applications.



e-business

SIS-West



Provide 24-hour Availability

Problem: 24-hour Home Banking required redesign into 24-hour database update with minor or no change to existing applications

Solution: New design of IMS Fast Path Data Entry Databases

Benefits: Legacy applications needed little or no change, to allow:

- Consistent reporting from on-line Databases
- Reporting on any historical information for the given time period
- Vertical view to the data (changes over time)
- 24 hour update of Databases

IBM

SIS West provides Savings bank services across Germany, handling 1000 transactions per second on 4 IMS systems. SIS West redesigned their customer information system to run in production for almost 18 months without interruption. The database was about .4 Terabytes of data, spread over 4 IMS systems. On-line changes are applied at any time. Several hundred reports are taken per day, some of them are based on final processing of the last day, others on last ultimo, or the 10th or the 20th of the month. Until June the customer allowed reporting on the last year-end. Some reports are taken on the last position. New applications are on development to deal with changes over time. A second database is in pre-production process. This is the savings account database, which is even larger. Due to the new technique, gradually, manageable, changing to truly 24-hour operation is possible without losing pace in a rapidly changing world. Hundreds (600-800) of legacy programs would have been affected in a regular redesign.

Today, banks around the world are providing home banking to their users. Credit Mutuel, in France, was one of the early users of home banking. They had provided access for their customers to their IMS applications and data with MQSeries Web solutions.



e-business

Victoria



Dynamic Workload Distribution

Challenge: Increase capacity to handle heavy initial growth of application workload; and allow for continuous unlimited growth for the long run.

Solution: Full database sharing utilizing both IMS and DB2 sharing capabilities; and complementing this with dynamic online transaction workload distribution with Shared Queues.

Benefits: Basis provided for unlimited growth

Victoria is a member merged into the ERGO group, the second largest insurance group in Europe. They have a centralized computer center in Dusseldorf, Germany, and they are executing about 4.5 million IMS transactions each day and serving over 8 million customers. The growth of their application workload was about to outgrow the capacity of their installed production base (H5 8-way). An upgrade to a 10-way model would only have put off the real issue -- how to deal in the long run with continuous, unlimited growth. Among other possibilities, they decided to go the way of full database-sharing utilizing both IMS and DB2 sharing capabilities because of its unlimited growth potential. To take full advantage of the new Parallel sysplex architecture, this was logically the first of two steps. Dynamic online transaction workload distribution complements database sharing and is the basis for the unlimited growth mentioned before.

Delivering IMS Function



e-business

2H98

Sysplex Sharing

IMS V6 VGR Enhanced

IMS V6 Open Database Access (ODBA)

IMS V6 OTMA Callable Interface

IMS Object Connector V2

Leveraging Java

IMS TOC Connector for Java (in VAJava 2.0 for NT)

Improving Tools

IMS Performance Analyzer V1 R2

IMS Y2K Exit (MFS)

IMS DBRC Secure

IMS Index Builder

IMS DB Control Suite

IMS Partition DB Version 2

IMS Parallel Change Accum

IMS Parallel Reorg

IMS Data Stream Tuner (for 3270 data streams)

IMS ETO Support Product

IBM

IBM had been providing a host of new function in the latter part of 1998 for IMS. These have included enhancements to IMS V6, delivered through the service process, including VTAM Generic Resources support enhanced to allow VTAM to own/manage the affinities allowinh end users to logon to another IMS in the event of failure, the Open Database Access (ODBA) facility with improved IMS DB access from other subsystem and a Callable interface to the Open Transaction Manager Access Facility (OTMA), new IMS Systems Management Tools (IMS Performance Analyzer, replacing IMS PARS and IMS ASAP with ease of use enhancements and R2 supporting Shared Queues; IMS Y2K Exit for correctly sequencing date key segments; IMS DBRC Secure to secure DBRC assets; IMS Index builder removing primary index rebuild restrictions; IMS DB Control suite providing front-end to IMS base, IBM performance, and third party utilities for reorg, recovery, and management of IMS assets, and on-demand space monitor facilities; Partition DB V2 providing partitioned index support; and Parallel Change Accum providing parallel operation of change accum), and new Java, Web enablement, and object facilities, delivered across the web with the IMS Connector for Java. And IBM continues to enhance its object-oriented programming support for IMS.



e-business

Middleware Subsystem Access

Provides enhanced access to IMS

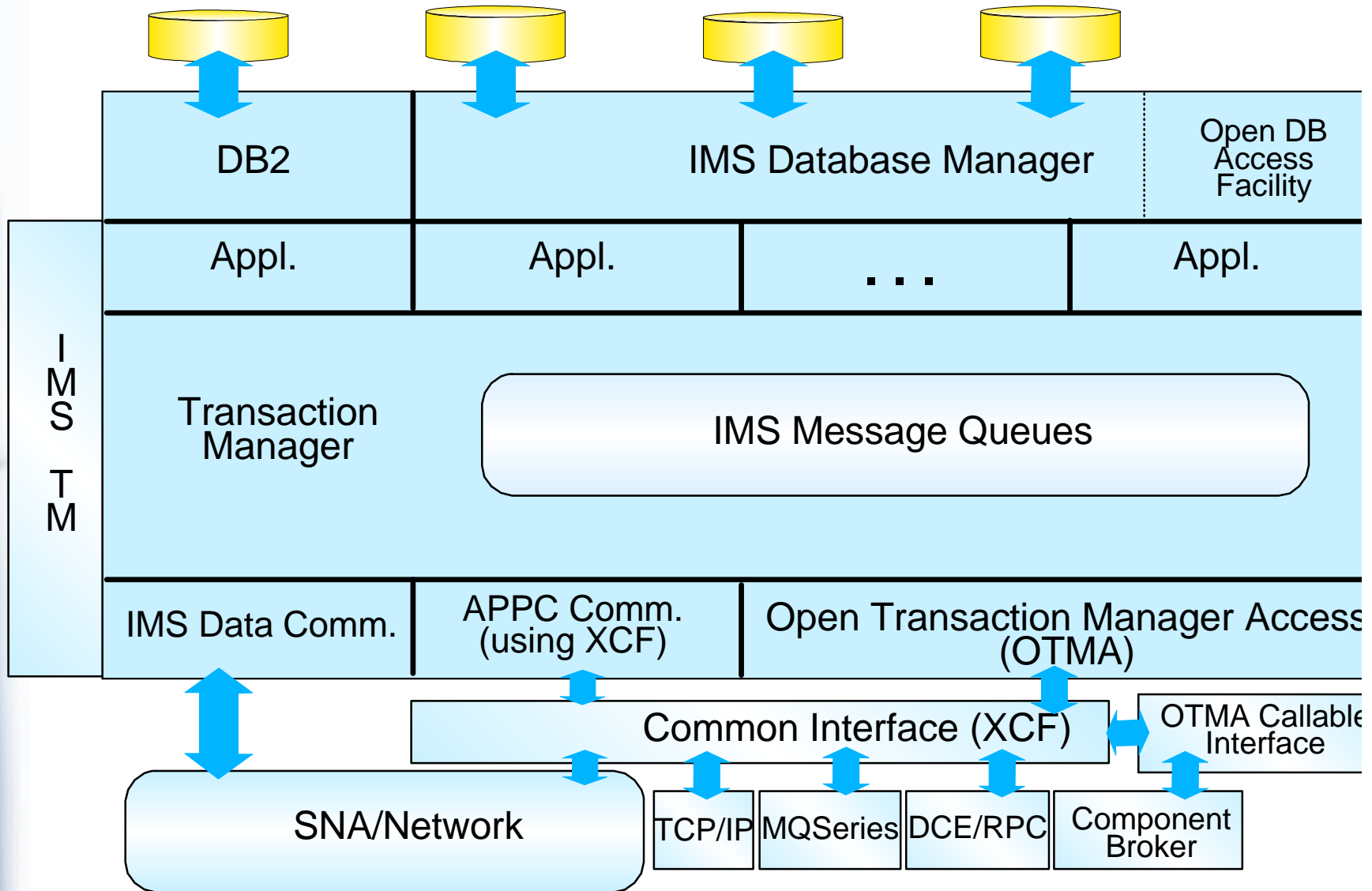

Traditionally messages come into IMS through its SNA data communication protocol from VTAM. With APPC/IMS support in Version 4, IMS took advantage of the new Cross Coupling facility (XCF) to communicate with APPC/MVS. This was a software facility that allowed MVS subsystems to communicate more efficiently.

With the IMS Version 5 Open Transaction Management Access (OTMA) facility, IMS extended its use of XCF for use by other IBM subsystems, such as MQSeries, and the new IMS TCP/IP OTMA Connection (TOC), providing them more efficient and richer capabilities in accessing IMS. OTMA allows access to existing, unchanged IMS applications on any IMS TM system on any MVS system of an MVS sysplex as well.

The recently available IMS OTMA Callable interface provides a high level interface for access to IMS applications from other OS/390 subsystems. It presents an API to a C or C++ program to enable access and execution of IMS transactions through the IMS OTMA facilities. With this simple and easy-to-use interface, the invoker of the APIs can submit a transaction or command to IMS from within the OS/390 environment without the necessity of understanding the more technical protocols of the MVS Cross Coupling Facility or the IMS OTMA. This enhancement makes OTMA easier to use, providing a callable interface for other IBM subsystems, such as those of the Component Broker technology, and for non-IBM subsystems as well.

The Open Database Access facility (ODBA), for easier database access, has also been recently provided. ODBA can be used for enhanced IMS Database access by other OS/390 subsystems, such as DB2 Stored Procedures. DB2 Stored Procedures can now access IMS DB data as well as DB2 data. Through DB2 Stored Procedures, and the IMS ODBA facility, IMS DB data could thus also be accessed more directly across the web using Net.data.



e-business

AGF-SI Group



**First in EMEA to implement
IMS TOC in production!**

Challenge: Provide the quickest access to IMS transactions from Thin client (less middleware than possible)

Solution: TCP/IP client access and Intranet access to existing IMS transactions (2-tier implementation)

Benefits: Maximize value of existing S/390 investment in IMS/DB2 applications and data

The IBM logo, consisting of the letters 'IBM' in a bold, white, sans-serif font, positioned at the bottom left of the slide. The background of the slide features a vertical strip on the left with a wireframe globe, a computer mouse, and a document with a URL, all in a light blue and white color scheme.

IBM

AGF-SI, a service company for the French Insurance group, AGF, which operates in 36 countries worldwide. Besides the continuous development of all information systems, AGF-SI is also responsible for implementing advanced technologies that are based on the network computing architecture. These projects have strengthened the company's position in its industry. AGF-SI's online activity is around 1.8 million transactions per day (an average of 35 DL/I and 5 DB2 calls per transactions). AGF-SI decided to minimize the number of software layers and hardware platforms between the client and the IMS server using the IMS TCP/IP OTMA Connection (TOC).

The IMS TOC provides enhanced communication linkages between remote workstations and IMS utilizing the IMS Open Transaction Manager Access (OTMA) facility. It supports multiple TCP/IP clients accessing multiple IMS systems.

40% of online activity at AGF today is processed through the IMS TOC to windows clients.



e-business

IMS Connector for Java in VJava

Accessing IMS from Java Applications:

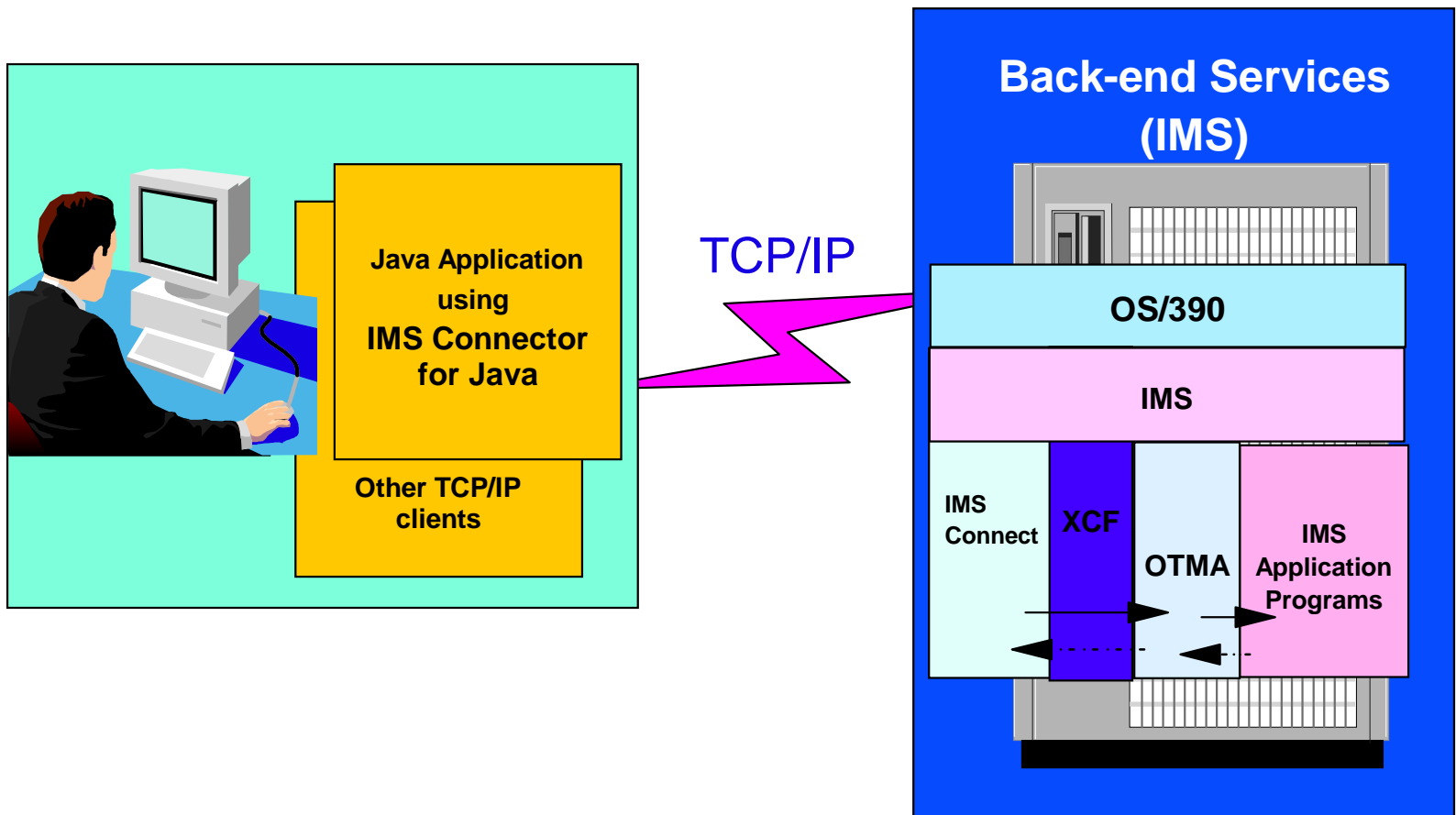

IBM

IMS is exploiting the latest programming technologies for the Internet and Java. This includes enablement of interactive and multimedia applications in a simplified fashion. With Java, users can transparently download and seamlessly run applications. It is becoming widely used and is platform independent.

IBM is also providing a Common Connector Framework with a set of common, consistent Java interfaces that connectors for any subsystem can and are implementing, making it easier for programmers not to worry about the differences between those subsystems. For such, IMS has provided an IMS Connector for Java in the VA Java Enterprise Edition Version 2.0. By being compliant with the Common Connector Framework, IMS Connector for Java can be used in any component server environment that supports the Common Connector Framework.

This can be used for the runtime environment of a Java Application. When a user executes the application and provides the appropriate input data, IMS Connector for Java within the Java Applications will establish a TCP/IP connection with IMS TOC on the host. IMS TOC will then forwards the transaction request to IMS OTMA (the Open Transaction Manager Access Facility provided initially with IMS V5), using MVS's XCF (Cross-system Coupling Facility) and sends the output back to the IMS Connector for Java.



e-business

IMS Connector for Java in VA Java

Accessing IMS from Java Servlets in WebSphere:

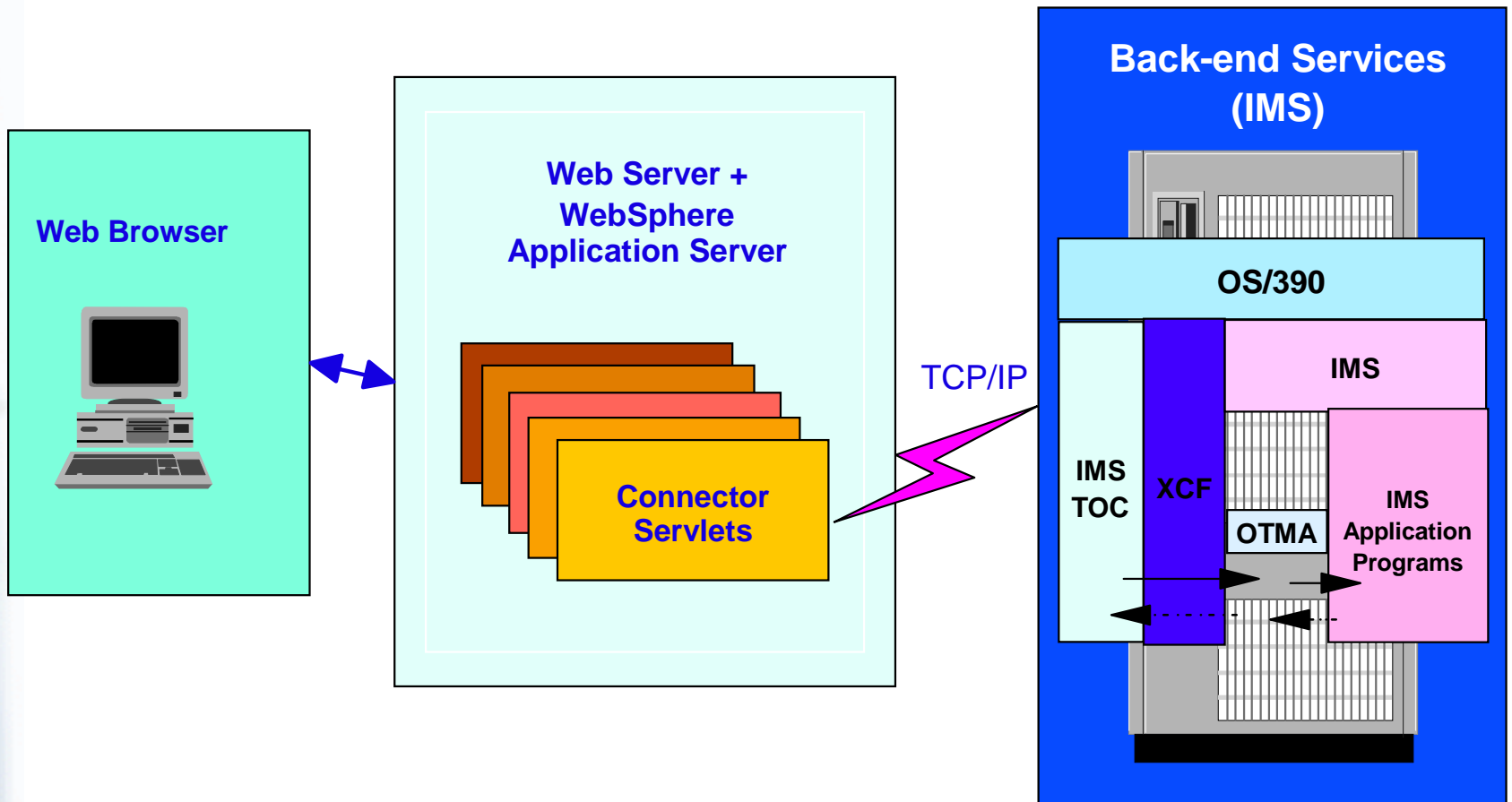

IBM

In the servlet runtime environment, a user can invoke the HTML page using the web browser and put in the input data. The request will be sent to the webserver and the corresponding servlet will be invoked by the WebSphere application server. The servlet will then use the IMS Connector for Java to establish and connect with IMS, and invoke the requested transaction with the input data through IMS TOC.

The output result will be handed back to the IMS Connector for Java in the servlet via IMS TOC and send to the output HTML page by the web server.

Development on NT can thus be deployed in any WebSphere environment.



e-business

IMS Tools 1999 Product Portfolio

Data Management - HP Utilities & Aids

- **DBT: (5685-093)**
 - SMU - HD Pointer Checker
 - HSSR - High Speed Unload
 - FRR - High Speed Reload
 - LMU - Library Management Tools
 - FACB - Fast Acbgen
 - Zapper - VSAM Zapper
 - Fast Prefix Resolution
 - SDO - Seq DAM Optimizer
- **IPR - Parallel Reorg (5697-D13)**
 - Unload
 - Reload
 - Index Builder
 - Fast Scan
 - Fast Prefix Resolution
- **IMS Index Builder (5697-C33)**

TM Management - Utilities & Aids

- **DST - Data Stream Tuner (5697-D69)**
- **ETO Support (5697-D68)**
- **MRQ - Message ReQueuer (5655-136)**
- **WLR - Workload Router (5697-B87)**

Database Administration

- **Control Suite (5697-D15)**
- **DBICF (5697-B92)**

IMS System Extensions

- **DBRC Secure (5697-D87)**
- **HD Compression-Extended (5655-085)**
- **Partition DB (5697-D85)**
- **Y2K Exit (5697-E04)**

Performance Management Tools

- **IMS PA - Performance Analyzer (5697-B89)**
- **DRCF - Dynamic Res Ctl Facility (5697-D14)**

Application Development, Cntl, Test

- **BTS - Batch Terminal Simulator (5655-A14)**

Backup and Recovery

- **DBT: (5685-093)**
 - ICE - IC w Pointer Checker & Compression
- **Recovery Saver (5655-A68)**
- **Parallel Change Accum (5697-E32)**

Fast Path - Utilities and Aids

- **DBT: (5685-093)**
 - DEDB UR -Unload/Reload
 - DEDB PC -Pointer Checker
 - DEDB TA -Tuning Aid
- **Fast Recover - Fast Path Recovery (5655-109)**

IBM has been providing a wide range of price/performance, competitive Systems Management tools for IMS. The tools provide support for speeding up and reporting on performance, extend the functions of and assist with testing of IMS, and provide system tools for querying, validating, managing, and tuning the IMS Database. These include for example tools necessary to maintain and repair databases.

Many tools serve multiple purposes. IBM offers tool functionality like IMS Control Suite that is not available from any other vendor. IBM offers high performance tools that are competitive within the industry at an affordable price. In fact when taken together "price/performance and functionality", IBM's IMS tool can be considered the best in the industry.



e-business

Tucson Medical Center



"IBM Delivers Cost Savings and Improved Availability"

Challenge: Run extremely lean shop on mainframe with performance, availability, simplicity

Solution: Replace existing Tools with IBM IMS Tools

Benefits:

- IMS DBT Fast Unload (HSSR) is faster
- IMS DBT Fast Reorg Reload is faster for HIDAM databases
- IMS Index Builder is faster
- Bonus of IMS Partition DB and still saved money

The classic IBM logo, consisting of the letters 'IBM' in a bold, sans-serif font with horizontal stripes through them.

Tucson Medical Center (TMC) conducted benchmarks between IBM's Database Tools and competitive Top of the Line tools. TMC was interested in evaluating IBM tools because of a concern over the cost of competitive tools. The challenge given to IBM was to prove that we had "comparable" performance and could meet TMC's reorg batch window times.

TMC's benchmark results showed successful performance. In addition, the extra bonus that TMC received was to implement IMS Partition DB to solve their data capacity and availability issues. Even with obtaining extra tools, TMC still saved money with IBM solutions.

To quote, Tucson Medical's conclusion was, "IBM delivers cost savings and improved availability."



e-business

Delivering IMS Function

1999

IMS V5/V6 Refresh

Tivoli Performance Reporter for OS/390

Systems Automation/390 IMS Feature

IMS V6 support via SA/390 service stream

IMS Classic Connect V2 for NT/AIX

Net.Commerce V3.1.2 for OS/390

IMS Dynamic Resource Control Facility

IMS V5/6 Database Fiber Optic Channel Support

IMS V6 Extended Recovery Control Coordination

The IBM logo, consisting of the letters 'IBM' in a bold, sans-serif font, with horizontal lines through the letters. It is positioned at the bottom left of the slide, partially overlapping a vertical blue gradient bar that also contains a faint image of a globe and a hand holding a mouse.

IBM

Earlier this year, IMS V5 and V6 were refreshed for easier installation and serviceability of enhancements.

The Tivoli Performance Reporter for OS/390 V1.4 became available offering centralized systems reporting over the enterprise, valuable in performance reporting, capacity management, service-level management, and accounting, and providing even easier access to enterprise-wide IMS data, via the new Viewer, a Java interface that allows graphical and tabular representations of Performance Reporter data from any desktop environment.

The IMS feature of the Systems Automation/390 product (providing single operations point of control for IMS) was updated to support IMS V6.

In April we provided a new version of the IMS Classic Connect product.

In addition for web enabling commerce we have announced a new release of Net.Commerce for OS/390 which provides access to IMS applications and data.

In keeping with our direction to continue to enhance our IMS Tools, we made available the Dynamic Resource Control Facility, an online monitor that puts comprehensive resource information at your fingertips and helps you spot and resolve potential problems before they become critical.

IBM also delivered IMS DB support for the S/390 Fiber Channel, the new high performance I/O channel being delivered with the new processors. FICON is a fully compatible evolution of parallel and ESCON channels and provides both improved I/O rates as well as additional bandwidth.

We are also providing IMS XRC Coordination to help synchronize IMS and DB2 data in an Remote Site Recovery environment.



e-business

IMS Business Intelligence

Extend the reach and value of your IMS data!

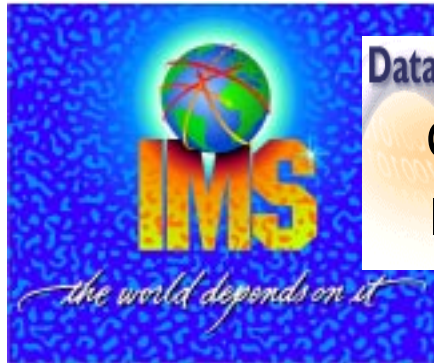

DataJoiner

Classic Connect

IMS Data Propagator

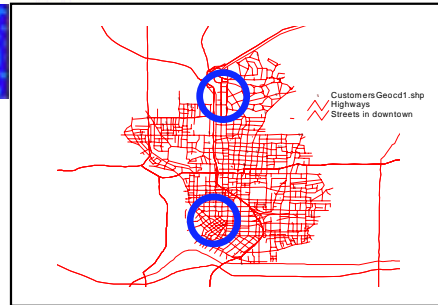

IMS data includes "implicit" spatial information

Challenge: Provide IMS customers with advanced data integration and analysis capabilities leveraging existing IMS data assets.

Solution: DataJoiner Classic Connect, DB2 Spatial Extender, DataPropagator technologies

Benefit: New forms of analysis possible utilizing IMS databases. Easily integrate IMS data with other business data in the enterprise.



IMS has been providing Business Intelligence solutions with Data Joiner's Classic Connect as well as with other data replication/propagation tools, such as the IMS DataPropagator. The IMS Data Propagator allows captured IMS database changes to be propagated into a DB2 database and vice versa. This can allow for consistent point in time data available across both environments. The IMS Data Propagator can provide IMS customers with advanced data integration and analysis capabilities, while leveraging their existing IMS data assets.

Classic Connect 2.11 made available earlier this year provided enhanced communication, data access and data mapping functions for customers using relational queries to access IMS and VSAM data. In conjunction with DataJoiner, users can, from a variety of client platforms, submit a standard SQL query that accesses IMS and VSAM data consistently with DB2 data. A workstation end user can issue an SQL join across IMS, VSAM, DB2 and non-IBM databases as well. Additional enhancements are provided for performance, scalability, reliability, and security.



e-business

IMS - Version 7

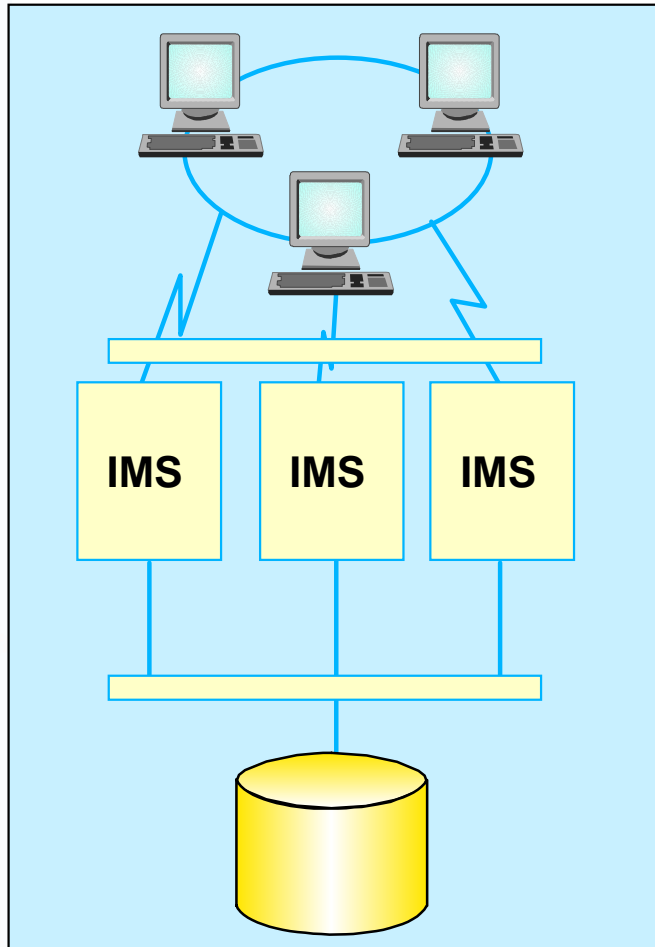

● Enhancements

- Enhance DB Recovery
- Extend Large Data Base Support
- Enhance Connectivity
- Faster Restart with Multinode Persistent Sessions
- Continuous Availability
- Systems Management
- Performance/Capacity
- Network Computing

● Benefits

- Enhanced Workload balancing
- Increased availability
- Enable customer growth investments
- Preserve current application investments
- Enabling new applications

Strategic, Open Access, S/390 Enterprise Server

IBM

To help all our customers with growth, availability, and systems management, IMS Version 7 is being provided. It includes the new Rapid Network Reconnect Facility, providing faster reconnect, utilizing the facilities of VTAM's Multinode Persistent Sessions. IMS is also providing enhanced support for database recovery, through a new Online Recovery Service feature. And IMS is extending its large database support and extending partitioning to other database types. It also includes the new IMS Connect a new feature for enhanced access to IMS through TCP/IP.

These enhancements, as well as additional support, is being provided to continue improvement in availability, systems management, performance/capacity and for optimizing use of IMS in enterprise and distributed computing environments.



e-business

IMS V7 High Availability Large DB Support for IMPROVED CAPACITY

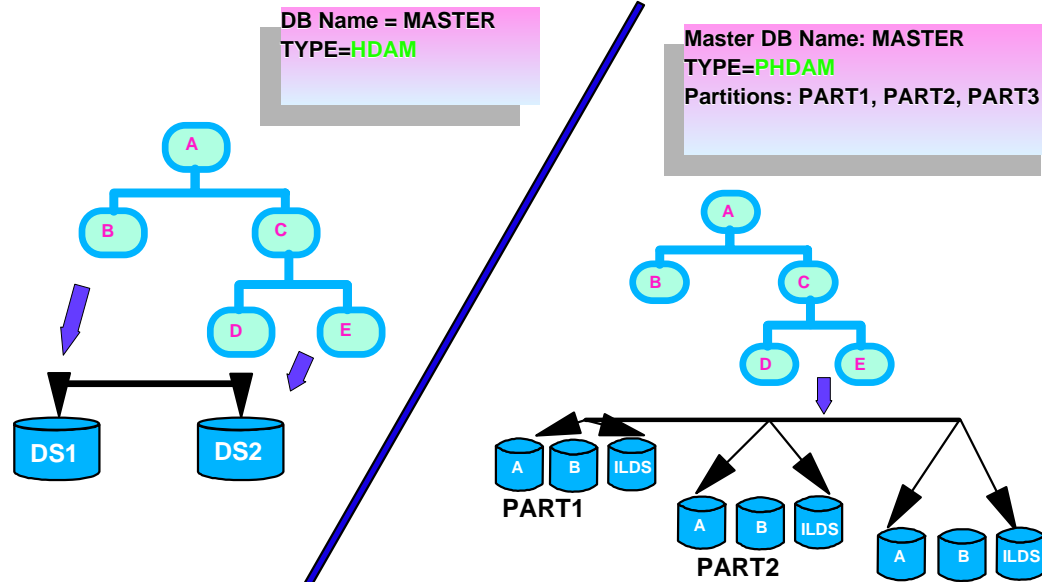

Objective:

- Extend IMS DB Full Function database size
- Provide data availability through partition independence.
- Provide smaller subsetting of the database making it easier to manage.

IBM

High Availability Large Data Base (HALDB) support allows for 1001 partitions to a max capacity of 40 gigabyte each. This means you can have over 40 Terabytes OSAM and VSAM databases. That would be 20,000 3390 devices. This works out to 6600 bytes for each person on earth. This compares to V5/6 when we just expanded to allow 8-gigabyte databases

This support also allows for a partition to be taken offline, have something done to it and be independently brought back online. This means each partition could be individually unloaded and reloaded and while offline a batch reorg could be done to on it. Or the entire database could be taken offline and each partition could be reorged in parallel, greatly speeding up the offline reorg process.



e-business

IMS V7 Online Recovery Service Feature for IMPROVED AVAILABILITY

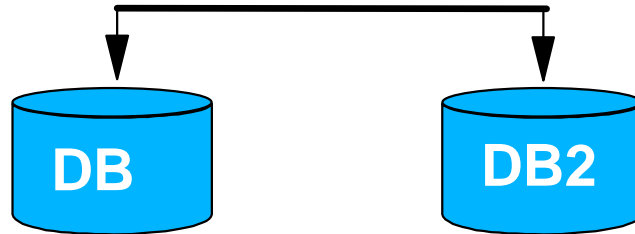

Objective: To provide database recovery processing in an online, IMS environment while offering customers

- Support for recovery from logs, simultaneous and point in time recovery
- Reduced time critical databases are unavailable in case of failure without operation and resource unavailability on an ongoing basis and on all critical databases
- Improved error recovery



The Online Recovery Service (ORS) is a separately orderable/priced feature of IMS V7. This feature gives a customer the ability to recover multiple database datasets by reading log volumes in parallel and applying the database changes to multiple database datasets simultaneously. Recovery-related processing takes place only when recovery is required. In addition, I/O overhead for recovery is reduced. This feature also gives a customer the ability to recover data bases to a 'point in time' which is earlier than the last committed updates.



e-business

IMS V7 Connect Feature for IMPROVED SYSTEMS MANAGEMENT

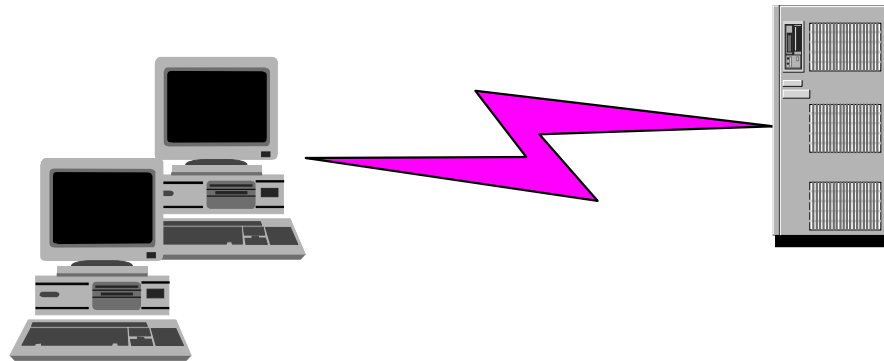

Objective:

- Improve performance with persistent sockets
- Enhance usability with user exits and asynchronous output support
- Ease serviceability with Dump formatting enhancements
- Enhance manageability with SMP support

IBM

IMS Connect, a new separately priced feature of IMS V7, provides enhanced IMS TCP/IP support. Enhancements include SMP installability, as well as enhancements for performance, usability, and serviceability.

New functions being added to the IMS V7 Connect feature include:

- Improved performance with persistent sockets.

Persistent sockets support eliminates the connect and disconnect used for each IMS transaction connection. The user has the option of specifying how long the connection should remain in existence.

- Enhanced usability with user exits and asynchronous output support.

Asynchronous output support allows IMS applications to direct output to an IMS Connect client under client-code control as to when to request the asynchronous output.

- Eased serviceability with dump formatting enhancements.

Dump formatting aids in the debugging of problems.

- Enhanced manageability with System Modification Program/Extended (SMP/E) support. SMP/E is the standard software used to ease installation and service of IMS.

Additional enhancements to TCP/IP support will be provided through the IMS V7 Connect feature.

IMS Version 7



e-business

Availability

- Online Recovery Service Feature
- Rapid Network Reconnect
- Enhanced Shared Queues/FP sharing
- SLUP session status
- RECON Upgrade/Coexistence
- I/O toleration
- Fast Path MADS enhancements

Performance/Capacity

- High Availability Large Database support
- DB Fiber Channel support
- DBRC enhancements
- Large DBRC Recon Record support
- MSC Descriptor Limit
- New Exits
- New execution parameters
- ACBGEN capacity/perf enhancements
- DBRC enhancements
- Fast Path Monitor support

Systems Management

- Connect feature
- Tivoli Readiness
- ETO Autologon and Printer enhancements
- SHQs Associated Printer support
- RACF PassTicket
- USERID/LTERM clarification
- Deferred ACB open
- MSC exit usability enhancement
- Diagnostics/Serviceability enhancements
- Compatibility enhancements
- Installation enhancements
- Commands enhancements
- Migration
- Additional Operator Information
- Logger enhancements



IMS V7 includes numerous other availability, performance and systems management enhancements. To name a few:

Rapid Network Reconnect, utilizing the facilities of VTAMs Multinode Persistent Sessions, permits IMS TM to automatically reconnect terminal sessions following any kind of IMS failure and subsequent IMS restart, thereby reducing network reconnect time after IMS, MVS or VTAM failure in a sysplex environment. It provides fast terminal reconnect to IMS by eliminating terminal logons and VTAM session startup traffic. IMS restart is required after IMS failure.

Shared Queues and Fast Path sharing enhancements, utilizing the coupling facility, provide asynchronous APPC/OTMA (open transaction manager access facility) shared message queue enablement, additional client support (multiple clients and additional client information and control), enable user autologon for a printer when application output becomes available and performance and miscellaneous enhancements to shared Fast Path Expedited Message Handler "(EMH)" and Sequential Dependent Segments (SDEPs).

IMS is being made Tivoli ready and enhancements are being provided for management of IMS through the Tivoli Global Enterprise Manager, and the Tivoli Manager for OS/390.

IMS Database Recovery Control (DBRC) enhancements improve diagnostics information, improve Database integrity protection, eliminate abends, provide large Recon record support, Recon loss notification, and migration/coexistence.



e-business

Next Steps in IMS Providing Integrated e-business Solutions

- **Enhanced Sysplex**
- **Systems Management**
- **Open Access**
- **Java**

Continuous Availability
Systems Mgmt/Usability



High Performance/Capacity
e-business Enablement

Strategic, Open Access, S/390 Enterprise Server

IBM

The IMS Transaction and Database Server for S/390 is evolving to further strengthen its support for Enterprise and Network Computing environments. As IMS customers grow and utilize the Sysplex environment, IMS support would be focusing on improved operations and Systems Management. Open access continues to be expanded and enhanced, in particular in the Java area. New Technology as it evolves, such as XML, would continue to be exploited. For this IMS continues to focus on performance, capacity, availability, security, integrity at the lowest cost.



e-business

Enhanced Sysplex/Systems Management

Enhancing

- Data Sharing
- Workload Sharing
- Network Sharing
- Operations

Tivoli

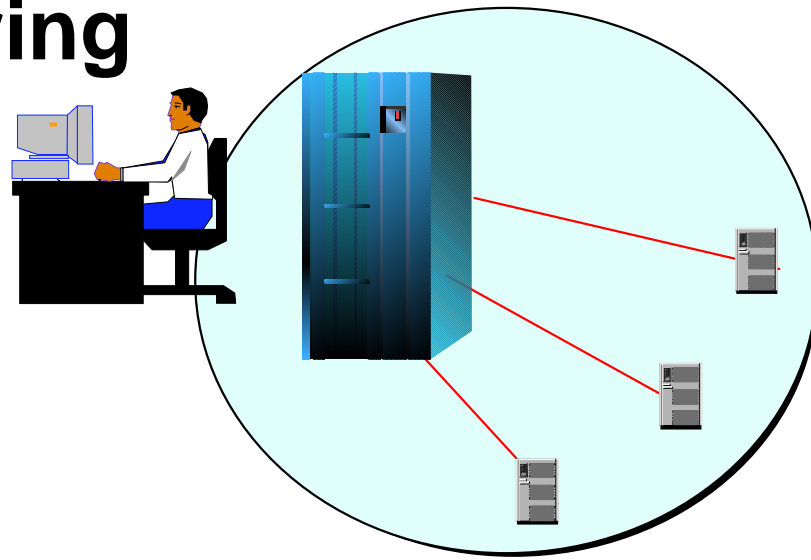

IBM

The IMS Transaction and Database Server for S/390 is evolving to further strengthen its support for Sysplex for improvements in data, workload, and network sharing. Transparent Terminal Recovery across Sysplex would be provided to continued higher availability into the future.

Systems Management too has been a key area with IMS customers. Each machine used to require its own console and operator. A single console and operator can now be used for displaying and handling the multiple console images for the multiple machines. Additional, consistent systems management across systems is being provided with Tivoli.

IMS has focused traditionally on ensuring a single system image. It has provided a single IMS MP image and has provided a single IMS image across systems with MSC as well. Sysplex wide resource management has also provided recent enhancements. IMS provides workload management information and supports VTAM's Generic resources to help with the balancing of work across the Sysplex. The IMS Automated operations interface too has assisted with automated operations. In the future, IMS is providing additional enhancements with Online Recovery Service, and later would be providing Sysplex-wide Resource management and Sysplex-wide single image operations.

Additionally, IMS has been providing continued enhancements to reduce the installation efforts. In this regard, IMS would continue toward reduction of the sysgen activity and an eventual genless system.



e-business

IMS Java Roadmap

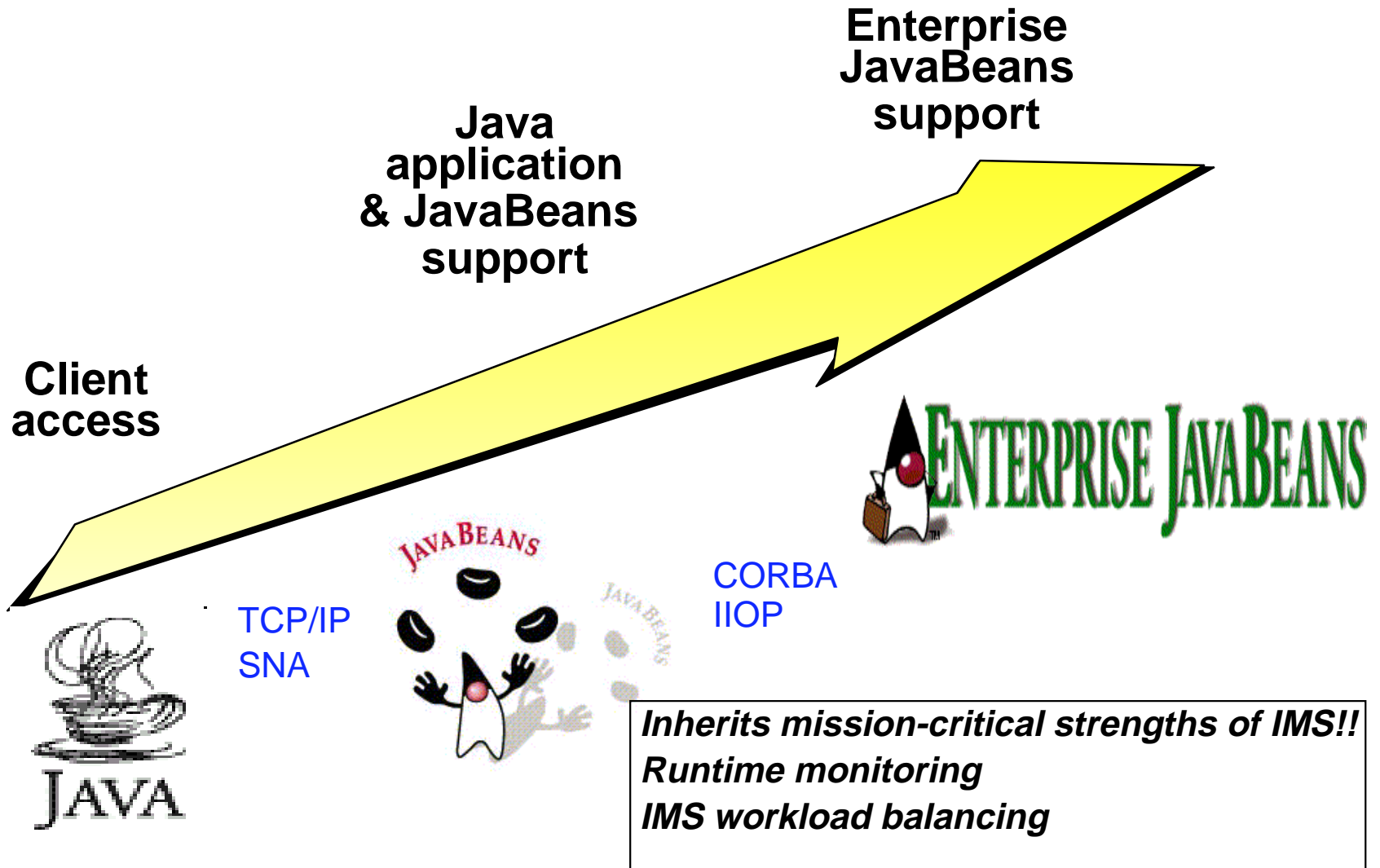

An evolutionary model...



IMS had provided initially the IMS Client for Java to help customers get started with Java. Now, along with VisualAge Java, IMS provided the IMS Connector for Java -- beans (session objects) for IMS access from a Java servlet, through Visual Age Java and the IMS TCP/IP OTMA Connection (TOC). The IMS Connector for Java enables the use of visual tools in generating Java applications with IMS access. Servlets could be created by the WebSphere suite of tools and deployed in the WebSphere runtime environment. Connectors can be "wired" into these servlets to provide remote access to Database, Transactional, and other back-end applications. The Programmer wires the beans using VA Java, and uploads the wired Navigator bean for servlet building. The Page Designer builds servlets using WebSphere Application Server tools and uploads completed Servlet for producer to deploy. There are many different Connectors shipped with WebSphere and VA Java. It is important that these connectors fit into a consistent usage model to minimize differences that programmers deal with to create servlets with remote system access. To this end, there are consistency requirements and a Common Connection Framework specification to define Java interfaces that Connectors are implementing to better fit with IDEs and VA JAVA EAB.

The Enterprise JavaBean Server and Container support is also being provided for scalable runtime environment to execute a large number of these IMS and other session objects concurrently. This support is being provided through Component Broker in conjunction with WebSphere.

IMS would also provide distributed coordinated commit for the generated servlet application with IMS applications and Java applications, running under IMS.

Java applications too could run under IMS control, accessing IMS DB and DB2 data.



e-business

Maintaining IMS High Availability

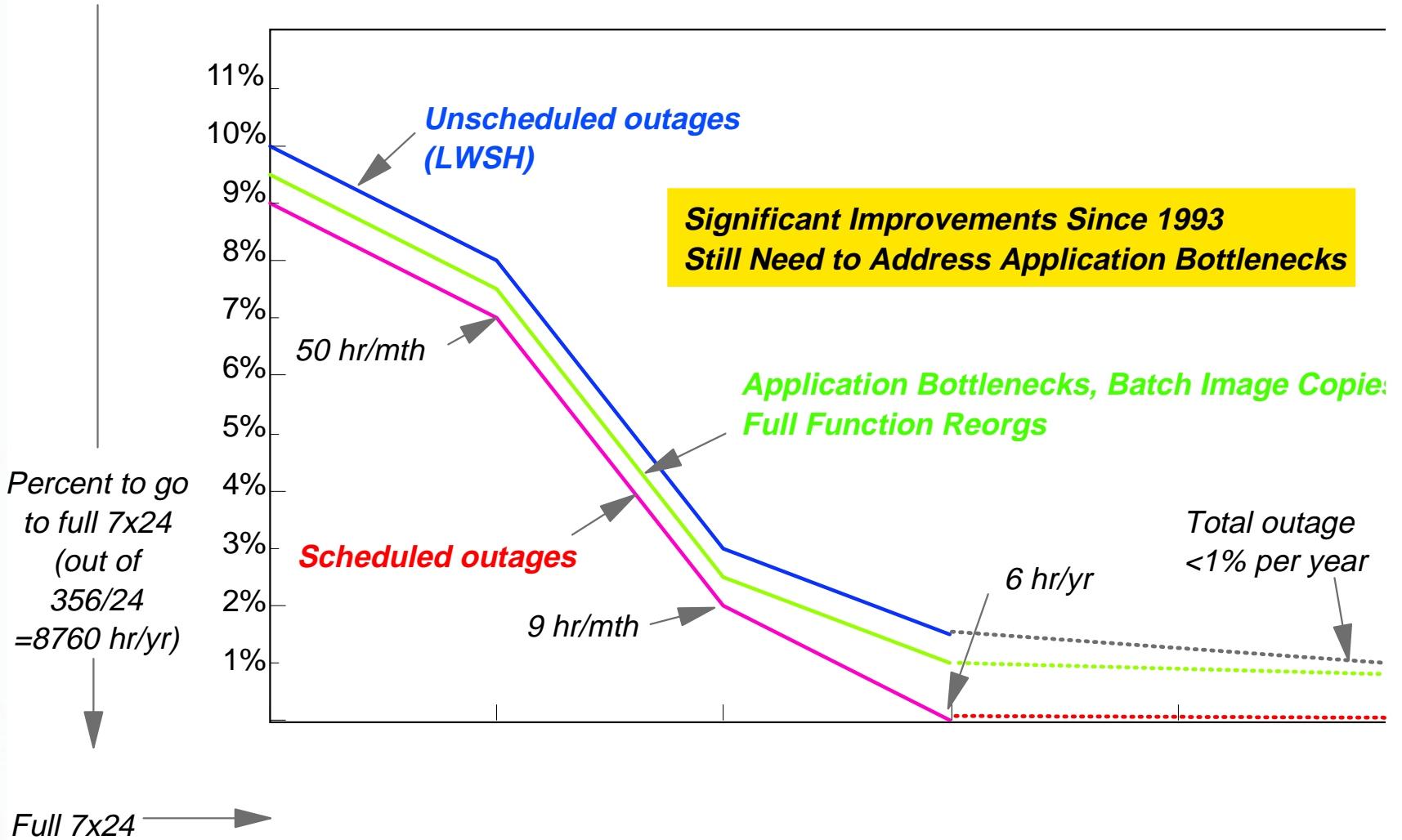

In looking at what IMS has offered its customers, high availability has always been very key to IMS customers. Since 1993, one customer has been driving down their planned and unplanned outage to less than 1% per year. Most of the scheduled outages have been taken care of. The bulk of what remains in scheduled outages is from application bottlenecks, batch image copies, and full function transaction reorganization activity.

Availability Improvements thru Defect Reduction



e-business

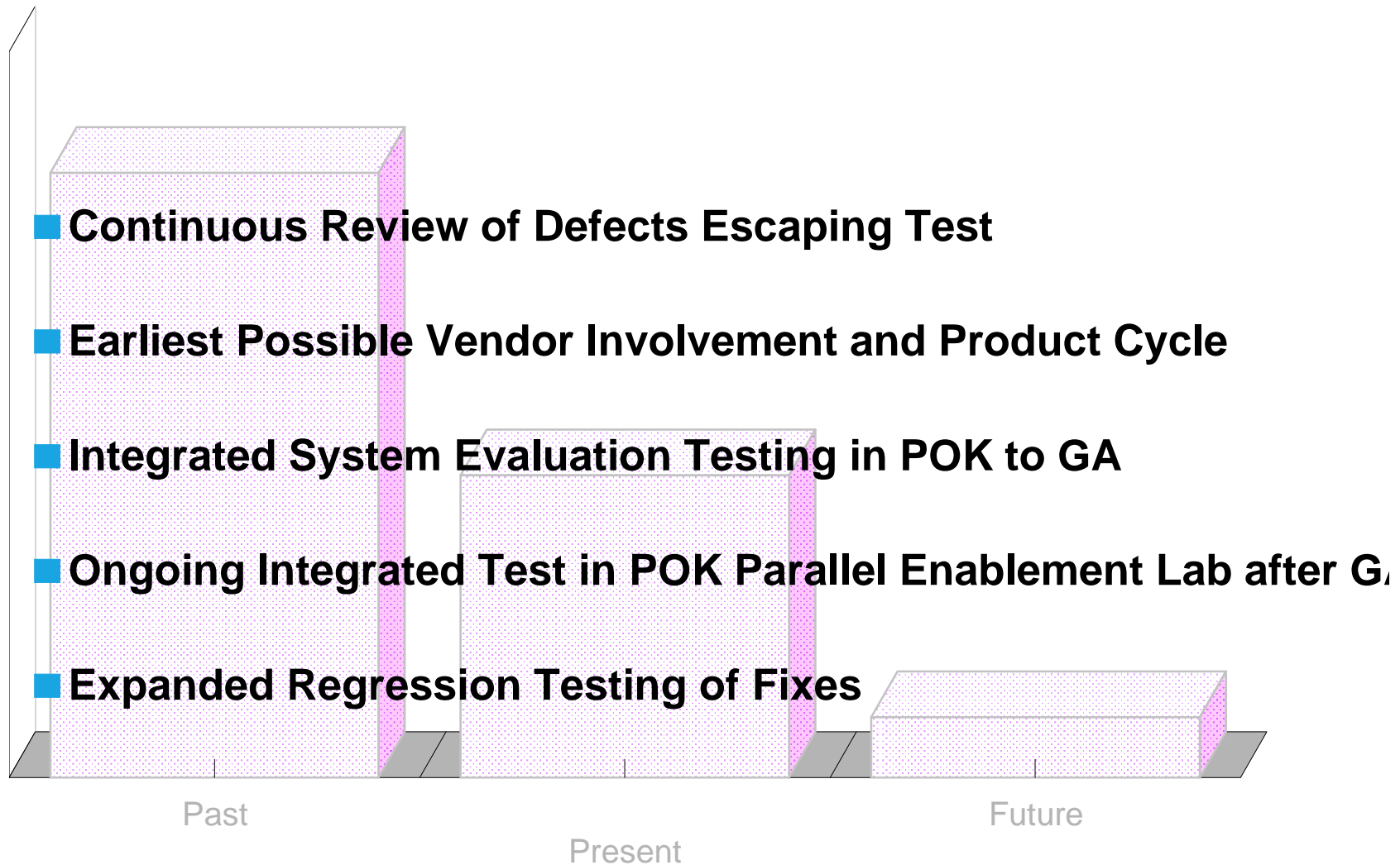

Defect Reduction

IBM

Significant ongoing work to reduce defects has been going on to improve the unscheduled outages and improve availability. That work has included continuous review of defects escaping test, early vendor involvement, integrated system evaluation test in POK before GA, ongoing integrated test in their Parallel Enablement Lab after GA, and expanded regression testing of fixes. This reduces any customer-seen problems and speeds up their installation process, as well as ensures continued improvement of availability in production.



e-business

End-to-End Performance

IMS Serving Mission-critical Applications and Data Access across the Enterprise and over the Internet

Transaction and Data access per second

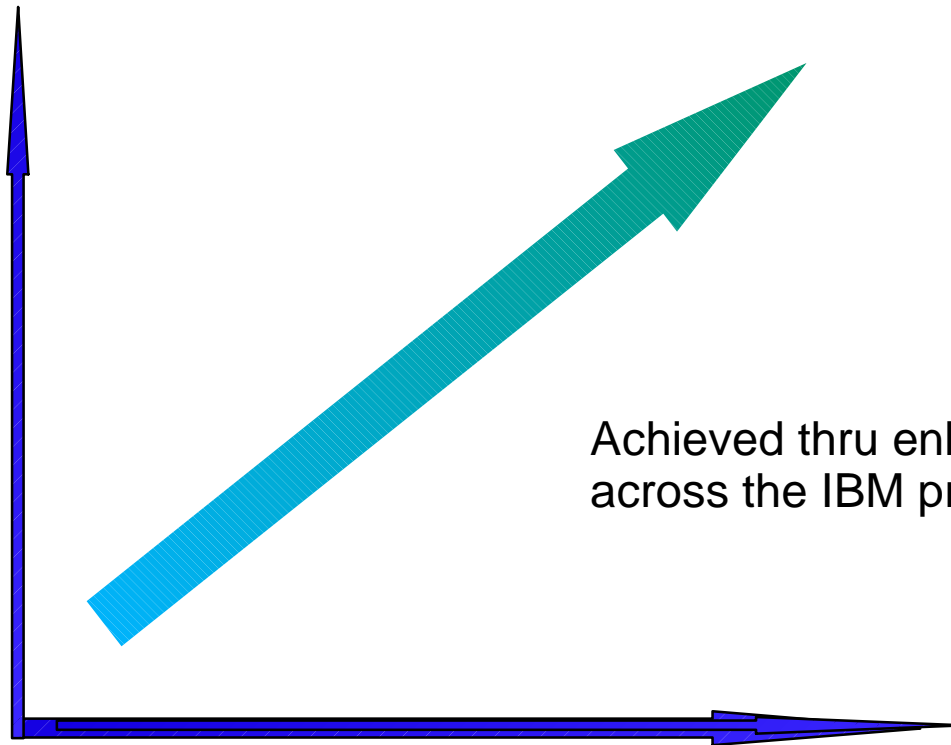

Achieved thru enhancements across the IBM product line.



In web computing the system must match capacity to business requirements on an as-needed basis and provide an easy growth path, minimize downtime and provide quick return on investment. These are available with IMS and the S/390. Recent enhancements have included improvements to the processing of requests, yielding overall increases in throughput. Performance improvements, higher bandwidth networking, and numerous other enhancements continue to make IMS and the S/390 a powerful, flexible system for growth in web serving as well as the rest of mission critical work.

IMS solutions exploit the security, performance, and other facilities of the S/390 to optimize performance. Testing with IMS TOC and with the IMS Connector for Java have demonstrated very high transactions rates.



e-business

Cost of Computing Evolution

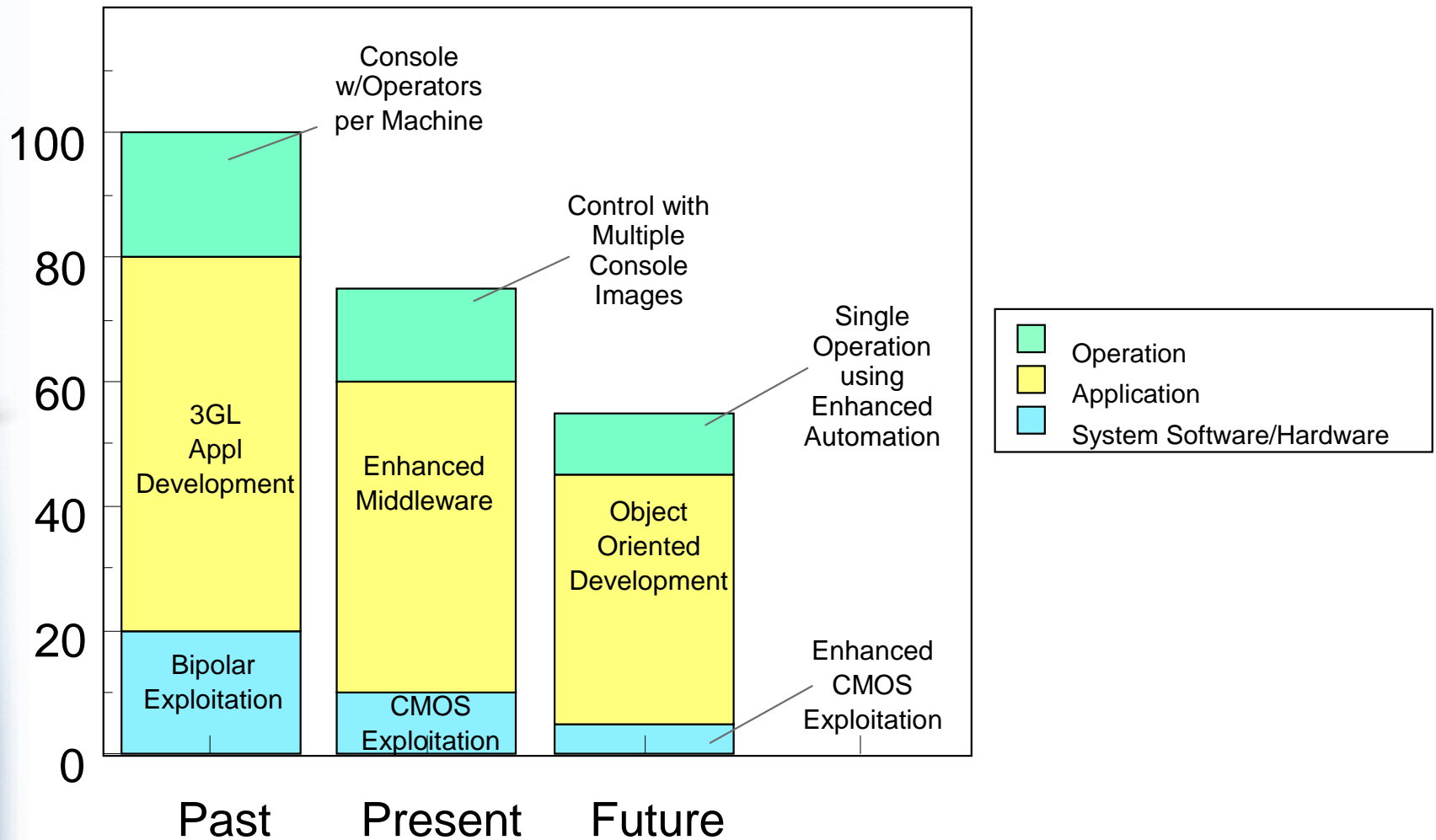

IMS has significantly helped contribute to bringing down the Cost of Computing. IMS operational and other systems management improvements have continued to bring down the costs of operations.

Enhanced IMS Middleware and Object Oriented Programming has helped lower the application costs. Focus now continues to help with the Application costs utilizing Java.

And by exploiting the new CMOS technology and other advances in technology in the hardware and operating systems, IMS has helped lower the systems software/hardware costs.

IMS: Powering e-business for the 21st Century



e-business



Transforming

core business processes with emerging technologies using IMS

Leveraging

existing investment of IMS knowledge & information



Building

new applications for IMS

Running

mission-critical programs in a scalable, available, safe environment with IMS

You enter the e-business cycle at any point -- focusing on leveraging your existing knowledge and information, transforming your core business processes, building new applications, and running a scalable, available, safer environment. You use existing data to sharpen decision making and responsiveness. You prioritize which processes and applications need to be extended. You build new reusable applications integrated with existing ones. And you maximize deployment on secure platforms. And for each of these elements of the cycle, we are providing you the IMS solutions that you will need to help make all this work easily. Built on the power of the S/390, billions of dollars worth of IMS applications have been developed to run your mission-critical work in a safe environment with IMS. If you have money in a bank, feed, house, clothe your family, or protect them with health or insurance services, use educational or government information, etc., most of the information about this is kept securely in IMS databases, accessed through high performance IMS transactions and rapidly being processed across the internet for wider use. IBM will continue to invest heavily in IMS to enhance IMS to meet the stringent requirements of its customers -- to help them transform their core business processes with emerging technologies using IMS. Exploiting the latest in technologically-advanced hardware and software, IMS will help customers achieve new levels of price-performance and, at the same time, leverage their exiting investment in skills and applications for access across the internet.