



A Practical Guide to IMS Connectivity and the Web

IMS Technical Conference - 1997
Session E36

Suzie Wendler
IBM
Dallas Systems Center



Abstract

For today's client/server and open environments, IMS has provided many ways to access the IMS Transaction Manager. This technical presentation reviews these and the IMS services that are used to provide this access. Among the connections covered are APPC/IMS, TCP/IP including Telnet and IMS Sockets, AS/IMS, OSF/DCE RPC, MQSeries, and the use of OTMA. The presentation also puts these connections into the perspective of Web access and discusses the basic concepts of Web connectivity.

Topics

- **Overview**
- **Sna Environment**
 - ▶ Traditional Connections
- **The TCP/IP Environment**
 - ▶ Connection Options
- **DCE/RPC**
- **Messaging and Queuing**
- **OTMA**
- **The Web**
 - ▶ What it is and how to connect to IMS
 - ▶ Available solutions

Network Connections

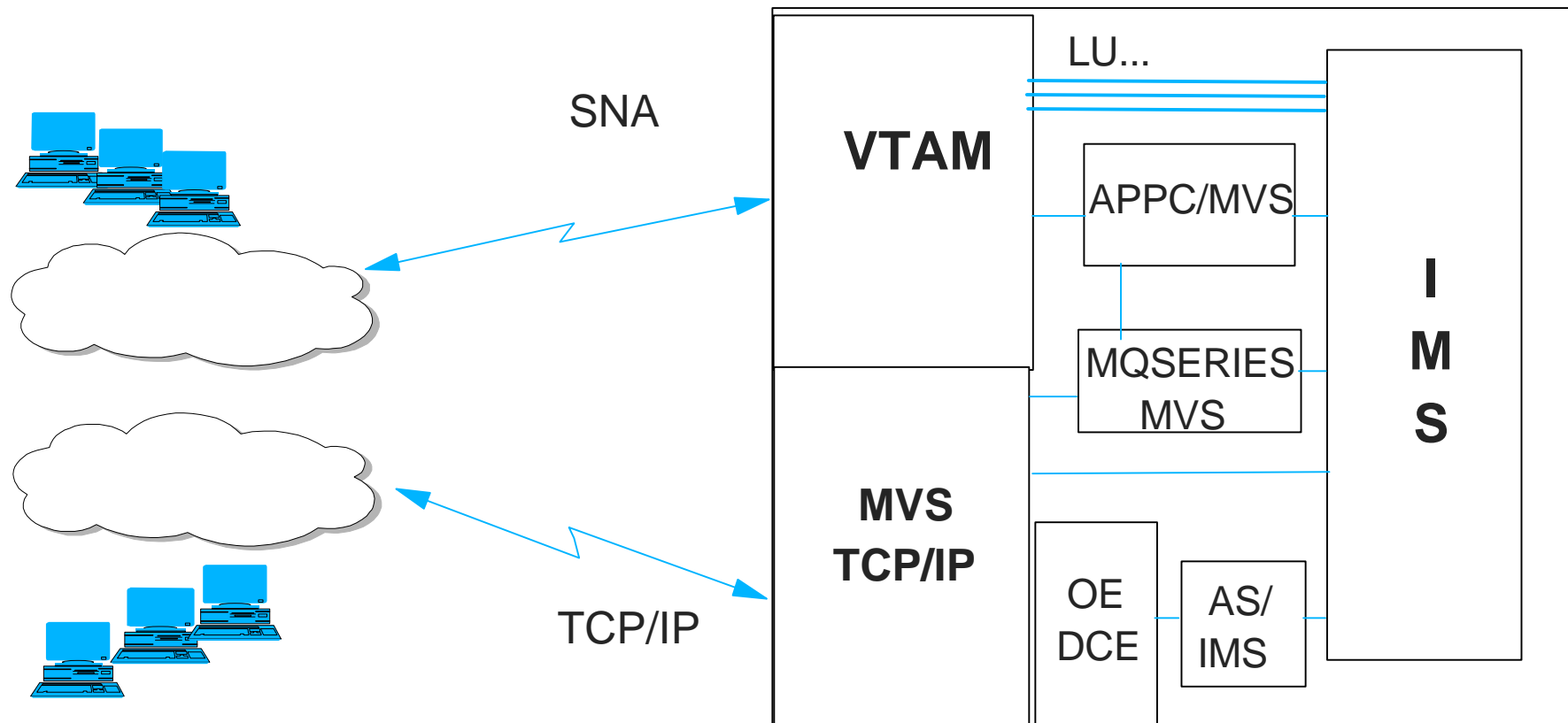

Application Connections

Transaction Model

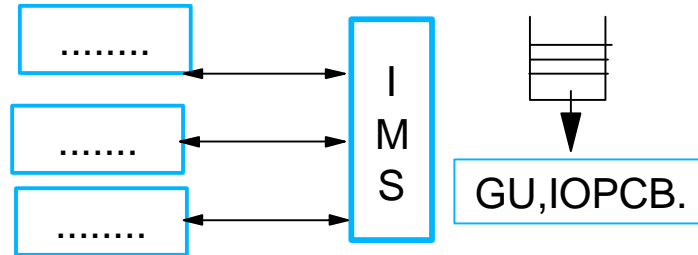

Conversational

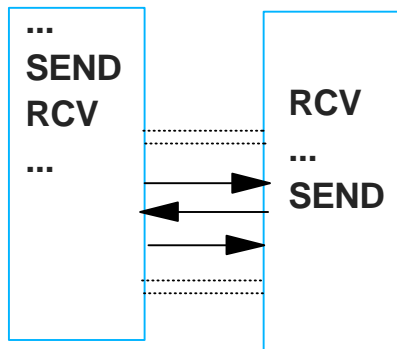

- ◆ Synchronous
 - ◆ Caller waits for reply
- ◆ Interactive
 - ◆ Multiple exchanges

Remote Procedure Call

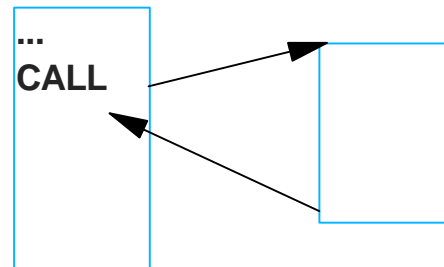

- ◆ Synchronous
 - ◆ Caller waits for reply

Messaging and Queuing

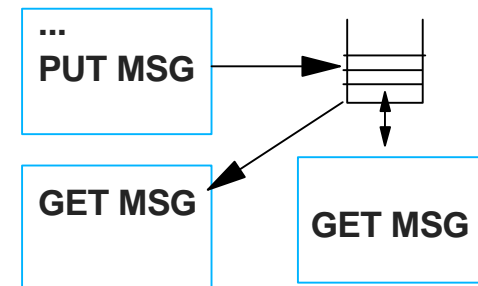

- ◆ Asynchronous
 - ◆ Sends msg and does not wait for a reply
 - ◆ Reply may be sent later

Web Connectivity...At a Glance

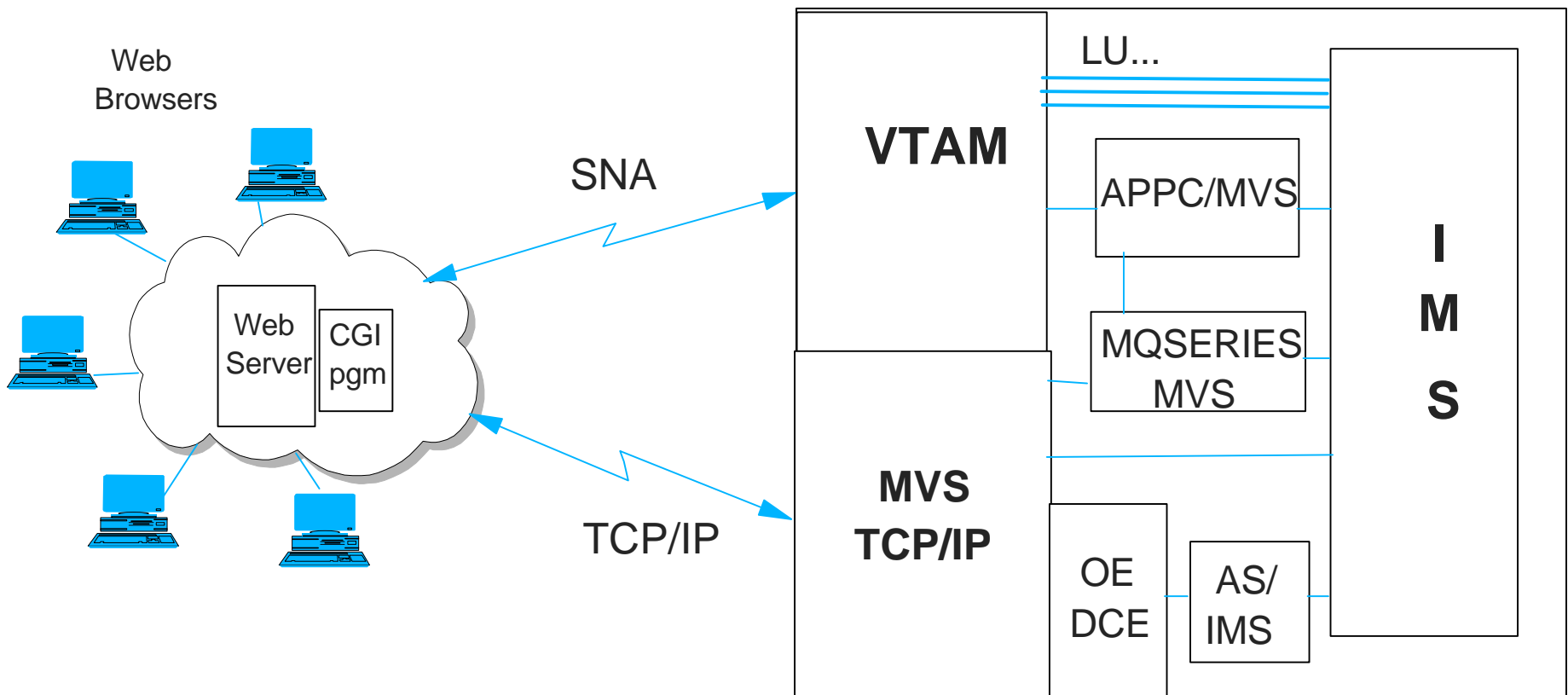

The SNA Environment

Connections Supported by IMS

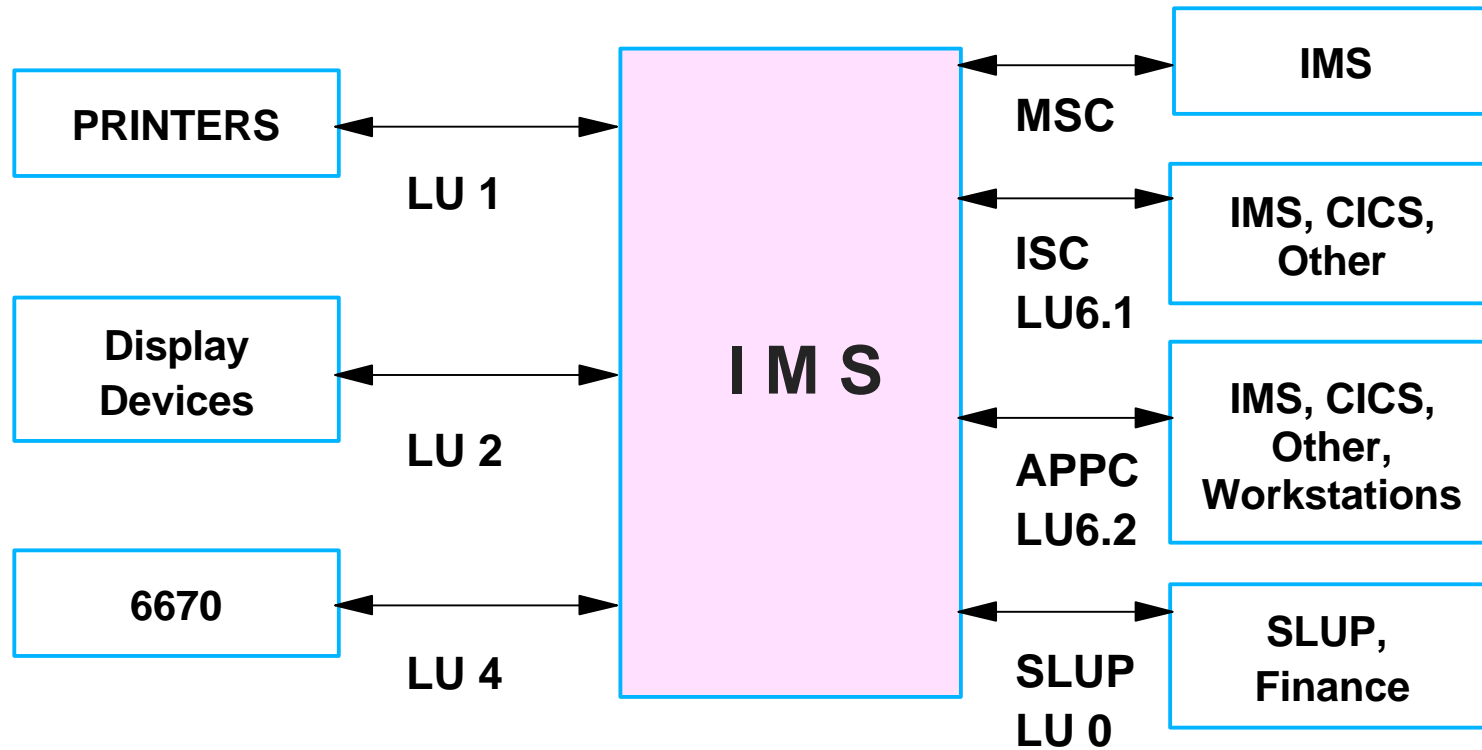

Fixed Function Devices

Program-to-Program

Connections Supported by IMS...

■ Common to all connections

- ▶ IMS executes communication flows on behalf of the IMS application
 - Based on system definitions

■ IMS applications use the standard DL/I call interface

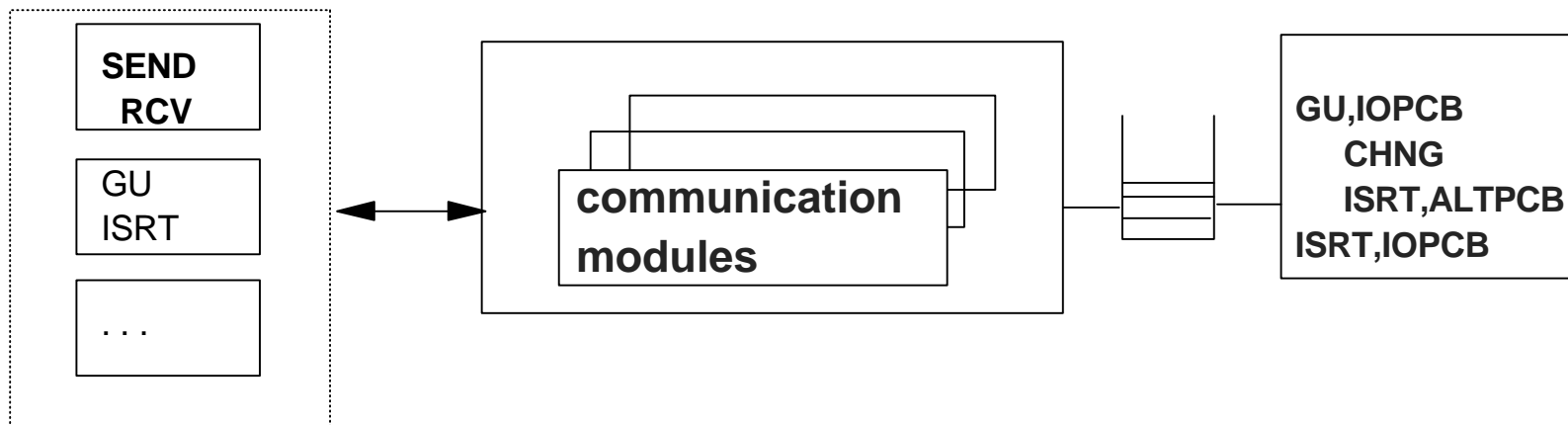

Unique Capabilities

■ MSC (Multiple Systems Coupling)

- ▶ Most commonly used protocol for IMS to IMS connections
- ▶ Private communication protocol
 - Provides the end-user with a "single system" image
 - Allows growth beyond the capacity of one system
- ▶ Allows IMS applications to be distributed
 - Program-to-program switches
 - Conversational transactions
 - No application program changes required
 - Destinations can be LTERMs or transactions

Unique Capabilities ...

■ **ISC (Intersystem Communications)**

- ▶ Commonly used over the years to connect IMS to CICS or IMS to RYO VTAM
 - Can be used to connect IMS systems
 - Not as transparent to the application program as MSC
- ▶ Implementation of the SNA LU 6.1 protocol
 - Connects host subsystems (program-to-program connection)
 - IMS
 - Executes communication flows on behalf of the IMS application
 - Responds to the partner waiting for a reply (e.g., response mode)
 - Initiates the communication process when needed (e.g., non-response mode)
 - IMS applications view the connection as an LTERM

Unique Capabilities ...

- **APPC (Advanced Program to Program Communications)**
 - ▶ Relatively new and tends to be the choice for workstation connections as well as new connections between CICS and IMS
- **Implementation of the LU 6.2 protocol**
 - ▶ Connects applications in different environments
 - ▶ Direct program-to-program connection
 - ▶ Conversational model
- **IMS provides two choices**
 - ▶ Implicit support
 - IMS handles all communication flows
 - IMS application continues to use the DL/I api
 - ▶ Explicit support
 - IMS application handles all communication flows
 - CPIC API

Unique Capabilities ...

- ◆ Conversational Model
- ◆ APPC Supports
 - Asynchronous
 - Synchronous
 - interactive

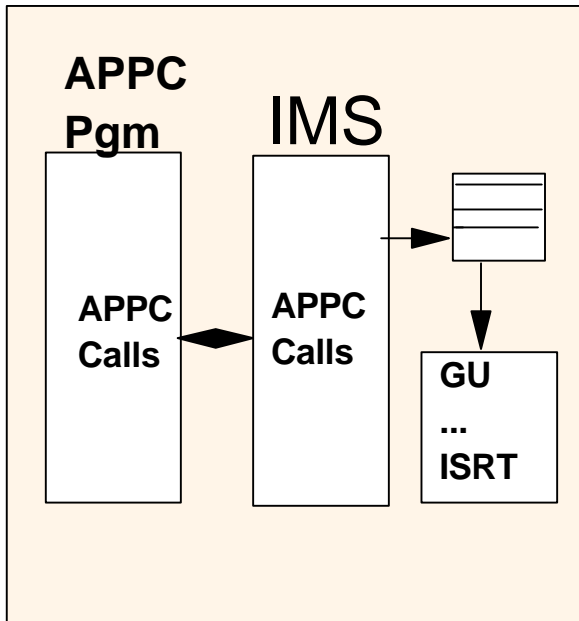
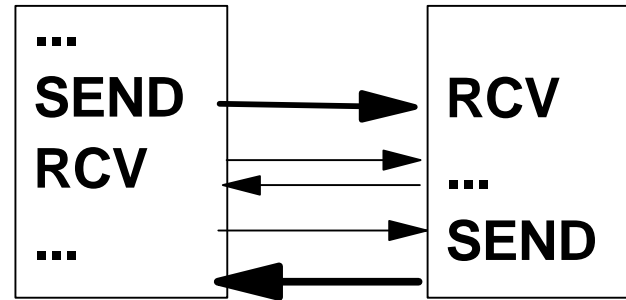

Standard

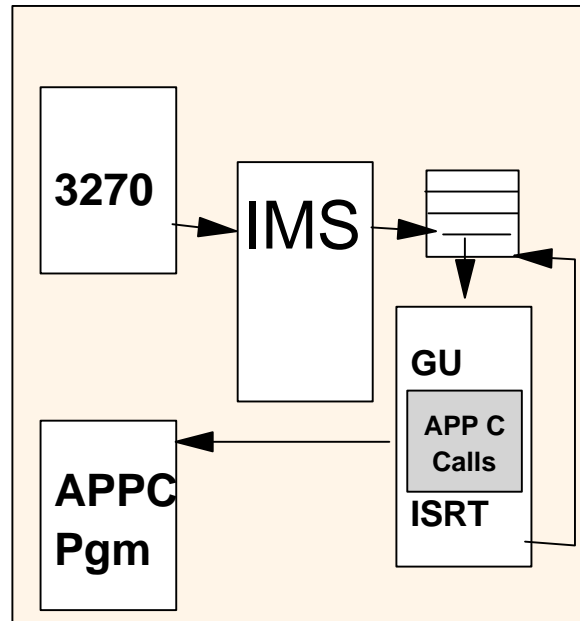

Modified Standard

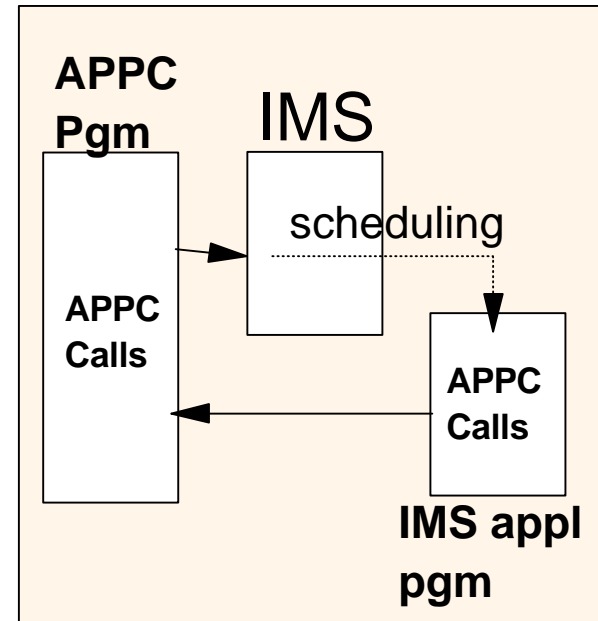

CPIC Driven

TCP/IP Application Protocols

TCP/IP -- Why the concern?

- **IMS applications are traditionally access via SNA, VTAM**
- **There is a growing need:**
 - ▶ For access to IMS applications from TCP/IP networks

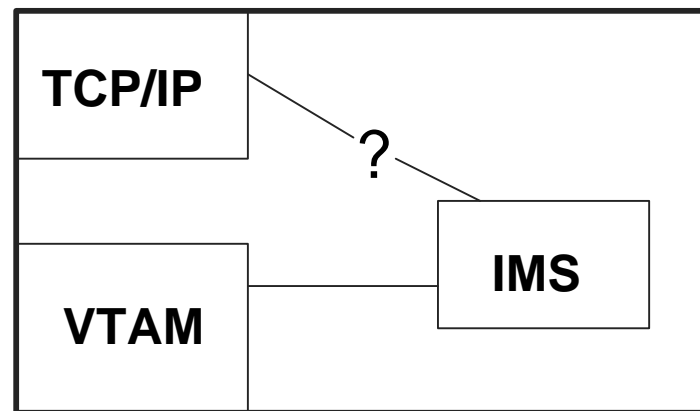

TCP/IP -- What is it?

- **A defined Protocol Suite**

- ▶ Communications protocol
- ▶ Set of Applications

- **Most common connection requirements**

- ▶ 3270 emulation
- ▶ Printer support
- ▶ Program-to-program communications
- ▶ The Web

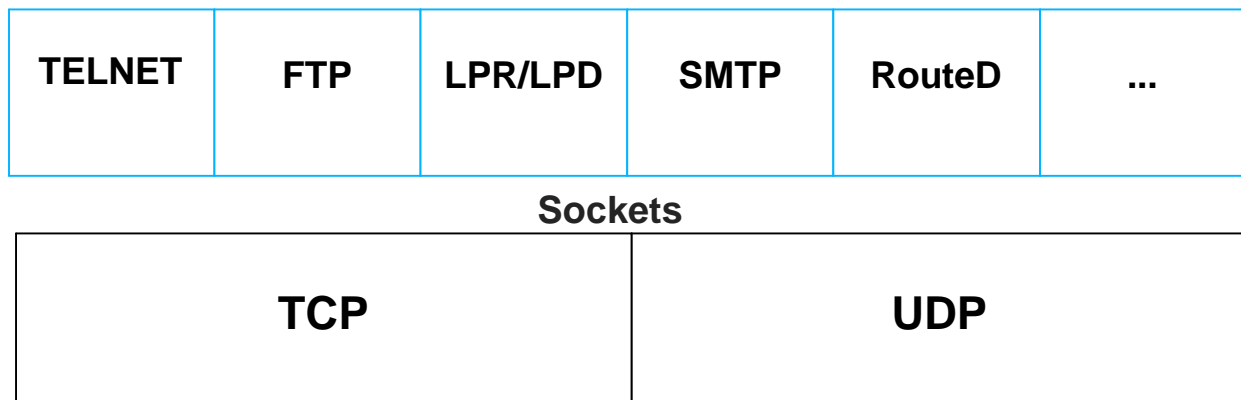

Application Protocols

■ Application layer protocol

- ▶ Describes peer-peer communications between two applications communicating
- ▶ TCP/IP applications are client/server models
 - A client initiates a request for a service
 - A server receives the client request at a well known port and provides that service

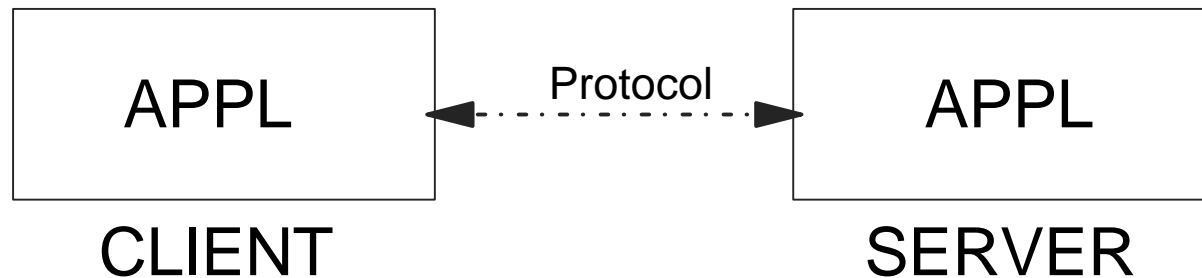

■ Daemon

- ▶ Never-ending process that receives a request and creates (forks or clones) another similar process that is more specific to the request based on the options passed

Remote Terminal Protocol (TELNET)

- **Widely implemented "internet standard" application**
- **Provides login to remote/local host**
 - ▶ Allows a user at one site to establish a TCP connection to a login server (Telnet daemon) at another site
 - ▶ Passes keystrokes from the user terminal and returns the output
- **Provides "transparency"**
 - ▶ Gives the appearance that the user's terminal is directly attached to the remote machine
- **TELNET server on MVS**
 - ▶ Establishes a session with IMS through VTAM
 - LU2
 - ▶ Allows the TCP/IP client to access IMS transaction

TELNET...

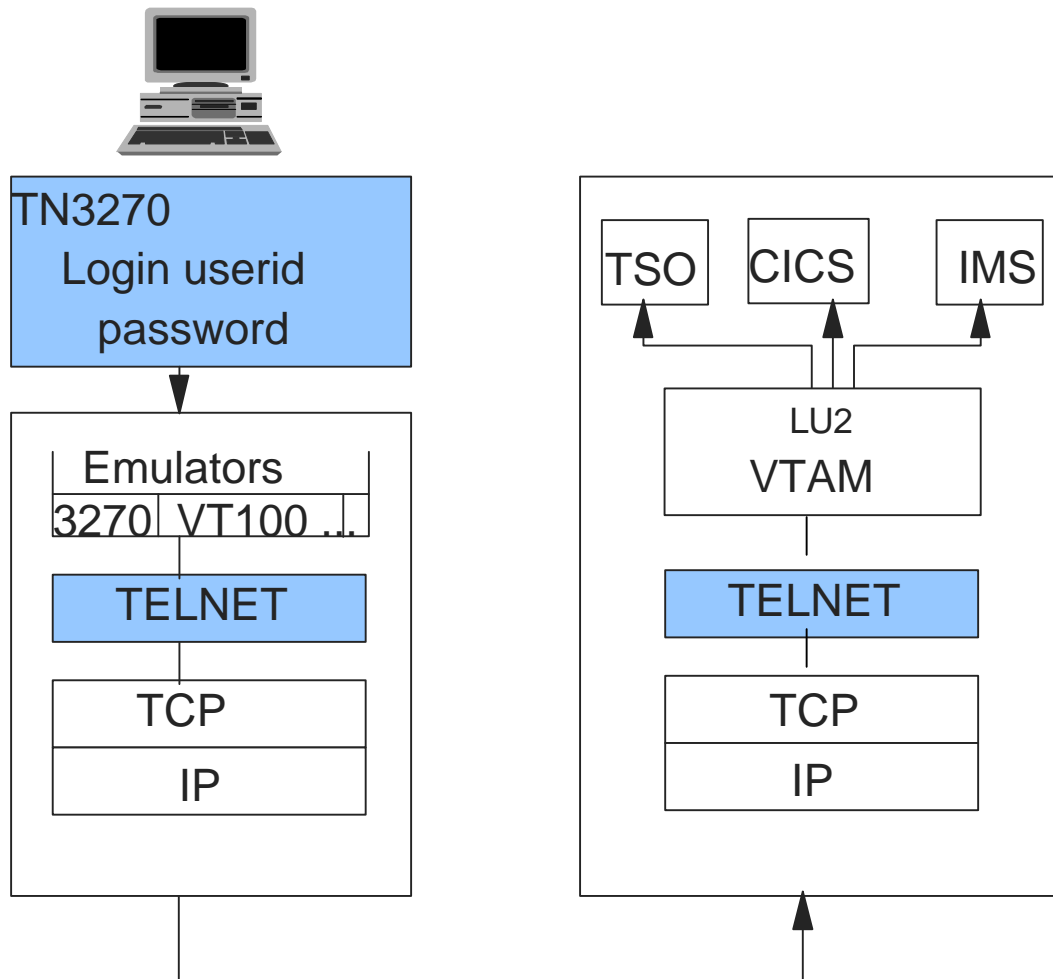

BEGINVTAM

** LOGMODES **

3278-2 LMD32782

...

** LU POOL **

TCP00001 TCP00002

TCP00003 TCP00004 ...

...

ALLOWAPPL TSO

...

RESTRICT APPL IMS

e.g. only 3 users

USER user1 user2 user3

Printer Support

■ Line Printer Daemon Protocol (LPR/LPD)

- ▶ Protocol to access print servers on a TCP/IP network
 - Spool print to a remote print server
 - Monitor progress of remote printing
 - Cancel print job spooled to the remote print server
- ▶ LPD (Line Printer Daemon) provides the server capability
 - Performs local print spooling
- ▶ LPR (Line Printer Requestor) provides the client capability
 - Responds to LPR protocol commands

NPF/IP PrintWay...

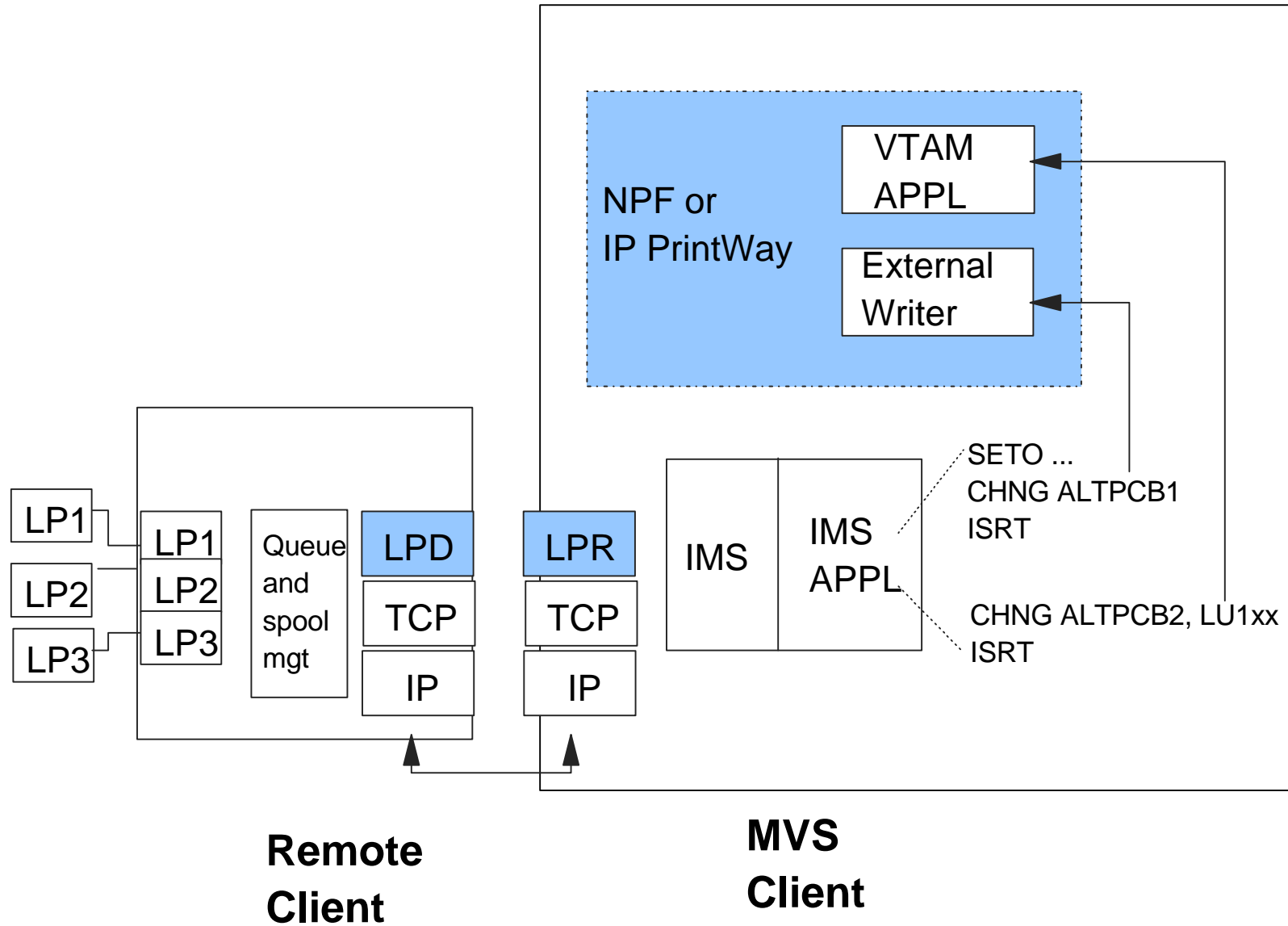

TCP/IP - Program-to-Program Support

■ Creating user-written TCP/IP applications

▶ Allows:

- Direct communication between two programs
- Support of the client/server model

▶ Requires:

- An interface for programs to request communication services
- "Sockets"

■ MVS TCP/IP provides:

▶ IMS Sockets support:

- Listener BMP, or
- OTMA access

IMS Sockets Support - Listener BMP

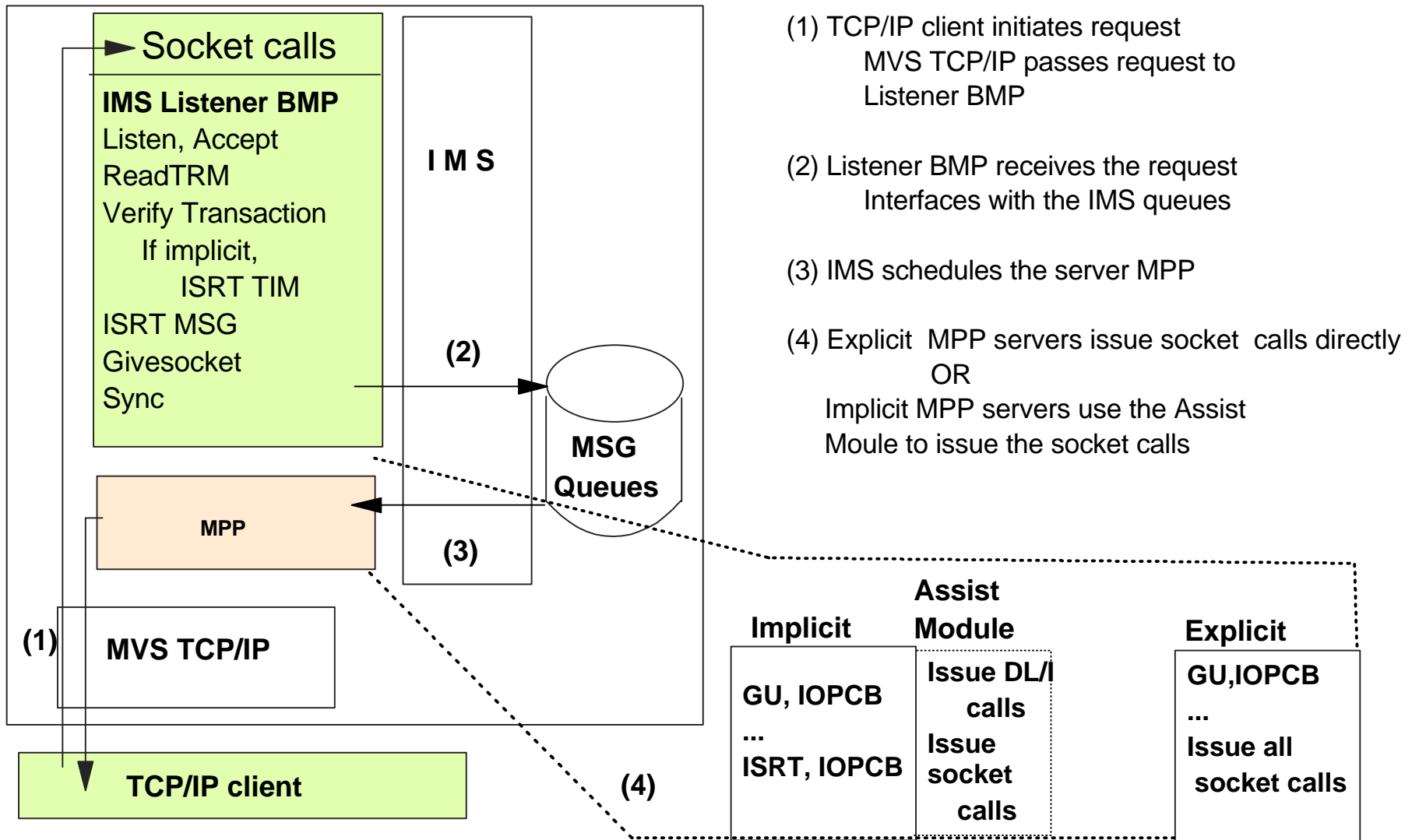

IMS Sockets Support -- OTMA

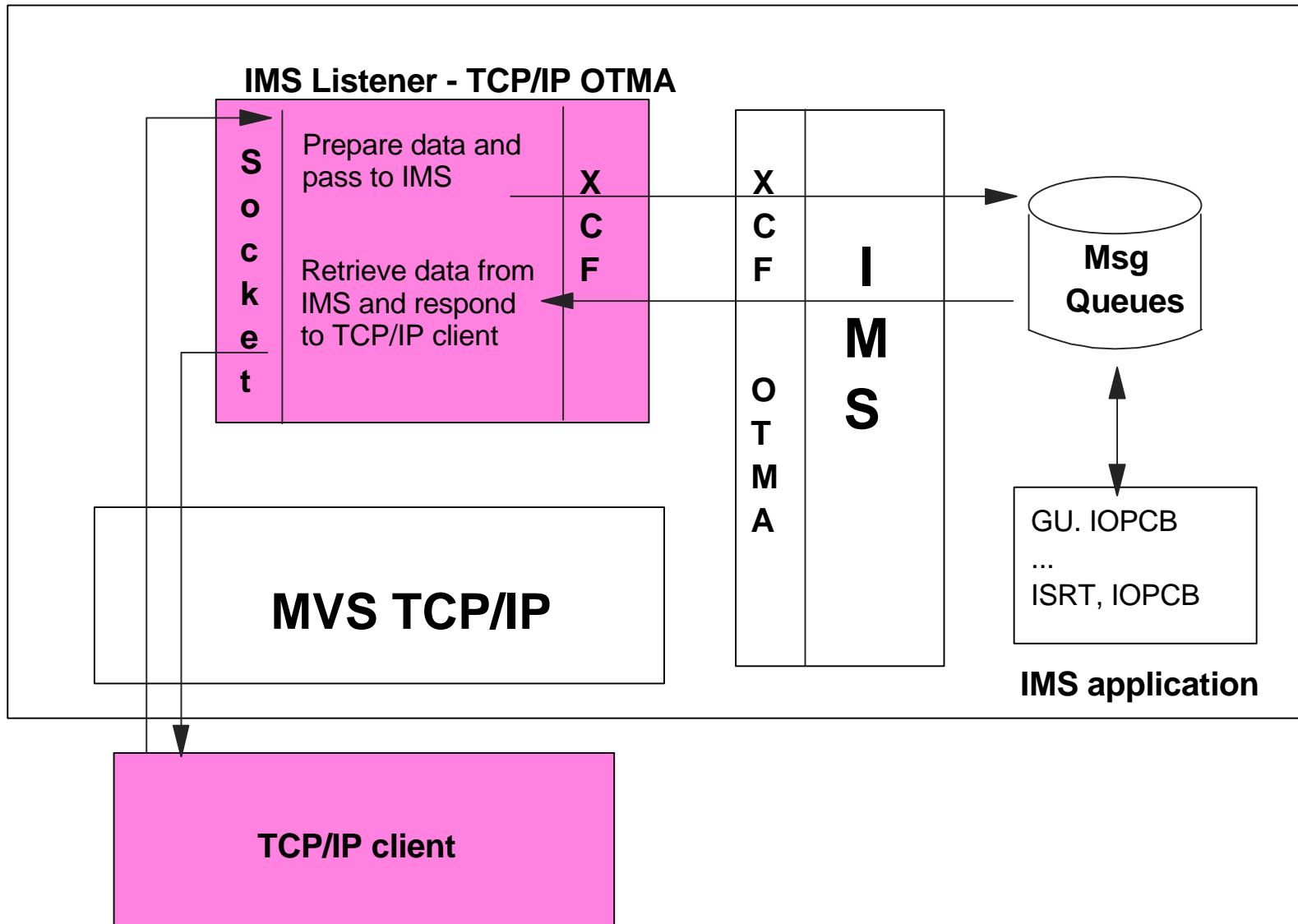

OTMA Support

- Support delivered in two parts
 - ▶ **MVS TCP/IP V3.2 PTF (UQ03104)**
 - Documentation
 - EZAIMSO0 delivered as a supplied exit for the OTMA host piece
 - ▶ **HWS (Host Web Server) component**
 - Downloaded from the IMS Home Page at <http://www.software.ibm.com/data/ims>
 - Two files that need to be uploaded to MVS
 - Configuration PDS (member can be added to IMS proclib)
 - Load library (member can be linked into IMS reslib or into any authorized library)
 - Startup jcl

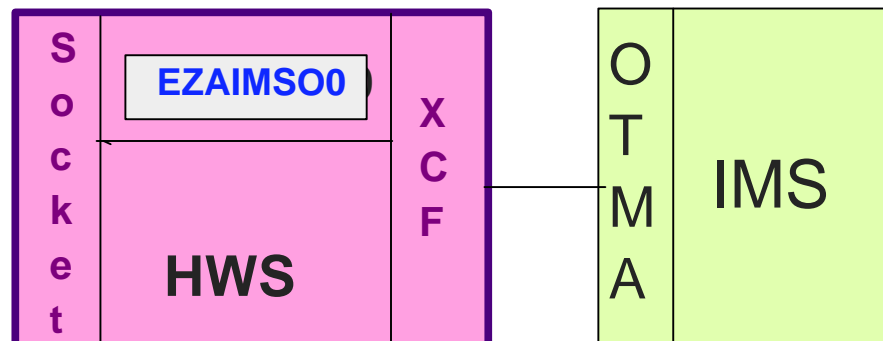

OTMA Versus Listener BMP

■ Use of OTMA

- ▶ Supports inbound socket connections
- ▶ Requires IMS/ESA V5 or later
- ▶ BAU IMS services
- ▶ BAU IMS environment
- ▶ IMS application use DL/I calls

■ Use of Listener BMP

- ▶ Supports inbound socket connections
- ▶ Any supported release of IMS
- ▶ Required if MPP server uses explicit socket call to receive inbound requests
 - Co-exists with the use of OTMA for other requests that are inbound implicit

The DCE/RPC Environment

DCE (Distributed Computing Environment)

■ DCE (Distributed Computing Environment)

- ▶ A layer on top of TCP/IP
 - Allows applications to issue Remote Procedure Calls
 - The calling application is shielded from knowing where the called procedure executes

■ What is it?

- ▶ A set of industry standards defined by the Open Software Foundation (OSF)
- ▶ Supports distributed applications
- ▶ Provides interoperability and portability across heterogenous environments
- ▶ Defines a comprehensive and integrated set of tools and services
 - Directory service
 - Security service
 - Distributed time service
 - Remote Procedure Call (RPC)

Remote Procedure Call... In Perspective

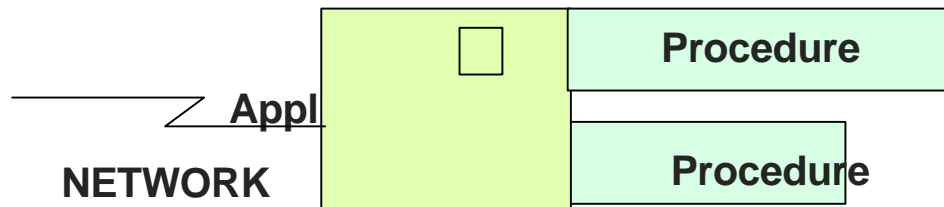

Structured application - processing all in one environment

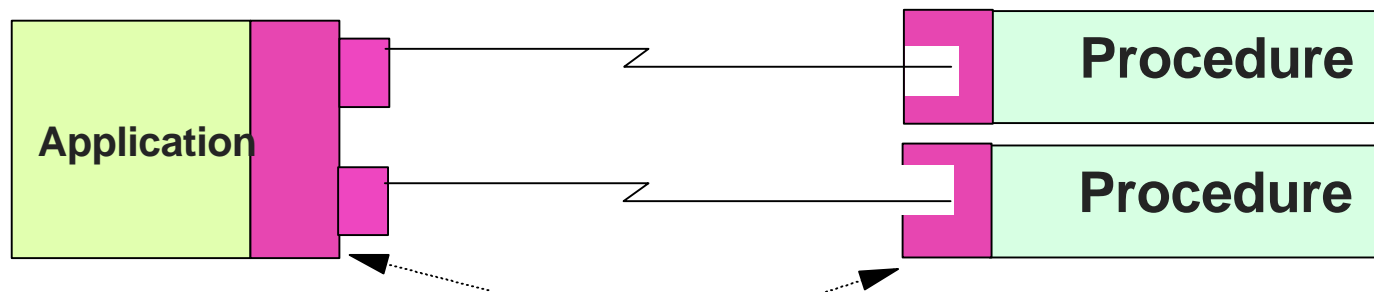

Distributed application - program coding required for communications

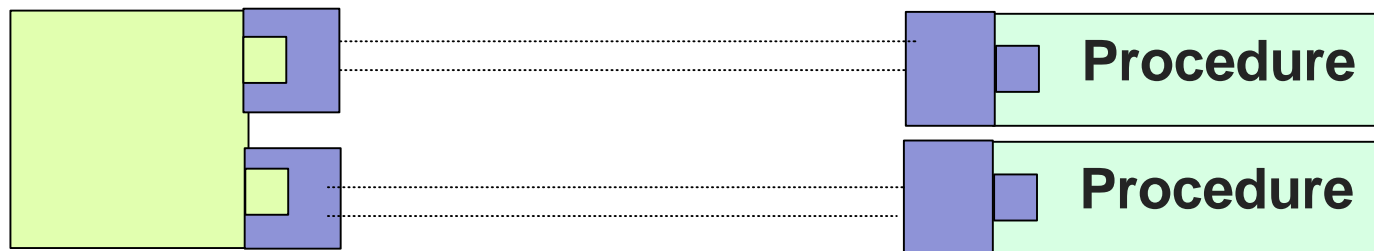

RPC application -- RPC generated stubs

DCE/RPC and IMS

■ AS/IMS (Application Server/IMS)

- ▶ Provides the DCE RPC support on behalf of IMS
 - For inbound requests
 - Where the IMS application is the called procedure
- ▶ Shields IMS and the IMS application programs from the DCE RPC environment
- ▶ Allows IMS and the IMS application programs to continue to use of DL/I

■ Outbound explicit application RPC calls

- ▶ Can be issued directly from IMS applications
- ▶ The requested procedure is outside IMS
- ▶ Capability does not require and does not use AS/IMS

DCE/RPC and IMS

■ RPC provides

- ▶ IDL (Interface Definition Language)
 - Automatically generates code that transforms procedure calls into network messages
- ▶ Runtime service
 - Implements network protocols for communication

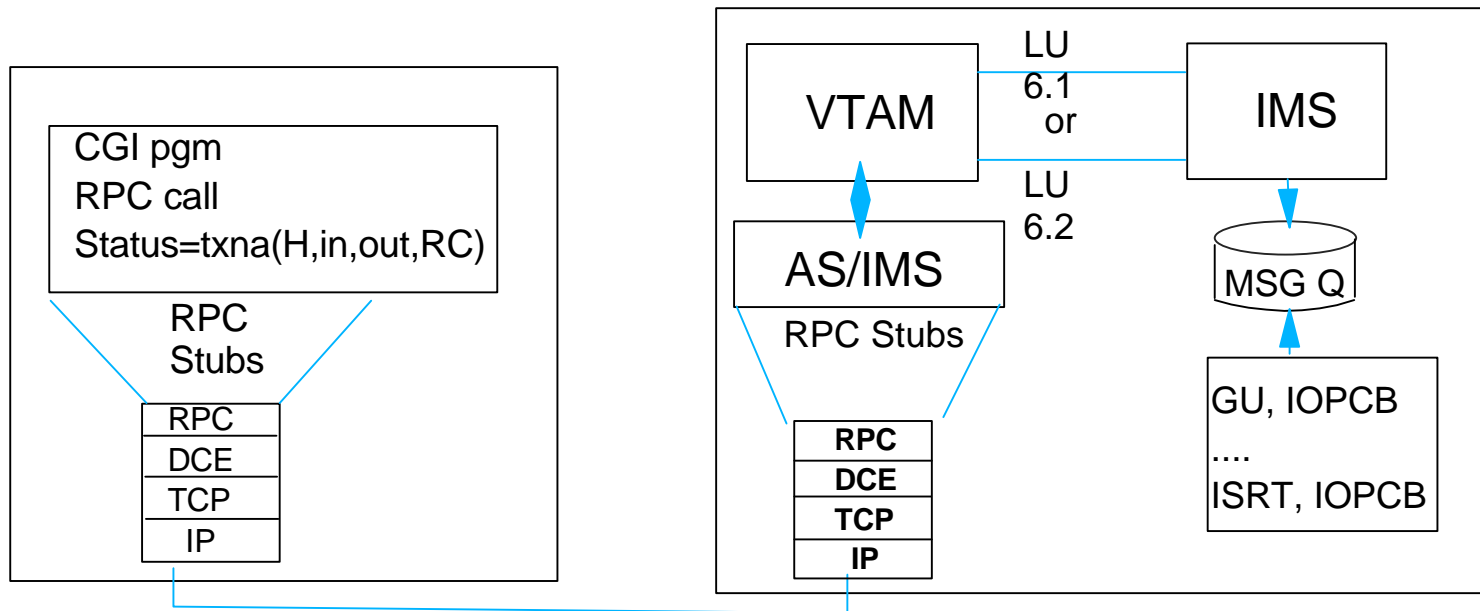

The Messaging and Queuing Environment - MQSeries

Messaging and Queuing

- **MQSeries is a series of IBM products that implement the messaging and queuing interface across products in the same or multiple platforms**
 - ▶ MVS/ESA, AIX, OS/2, OS/400
 - Applications are not involved in communications
 - Common API which is consistent across the platforms
 - Assured message delivery and syncpoint participation
- **The concept of messaging and queuing is one well understood by IMS users**
 - ▶ MQSeries globalizes this model

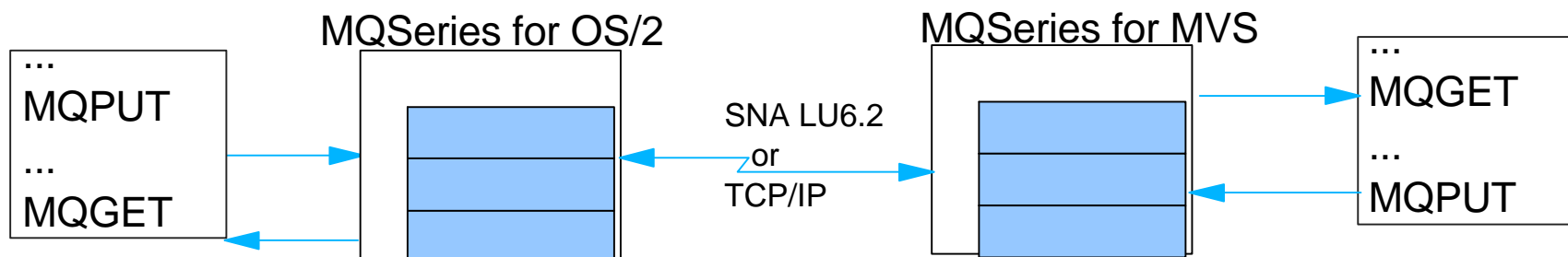

MQSeries for MVS/ESA

■ MVS Subsystem

- ▶ Supports connections to CICS, IMS, Batch and TSO
 - Provides recovery and restart

■ Support for IMS

▶ IMS Adapter

- Support includes a Trigger Monitor (BMP) for inbound requests
- Puts a special message on the IMS queue for the MPP that gets scheduled
- Uses the External Subsystem Interfaces (ESS)
- Similar to the DB2 connection
- IMS applications issue MQ calls to retrieve messages from and send messages to the MQ queue

▶ IMS Bridge

- Uses the IMS/ESA V5 OTMA support
- Allows access to legacy applications (GU and ISRT, IOPCB calls)

Connecting to IMS - - IMS Adapter

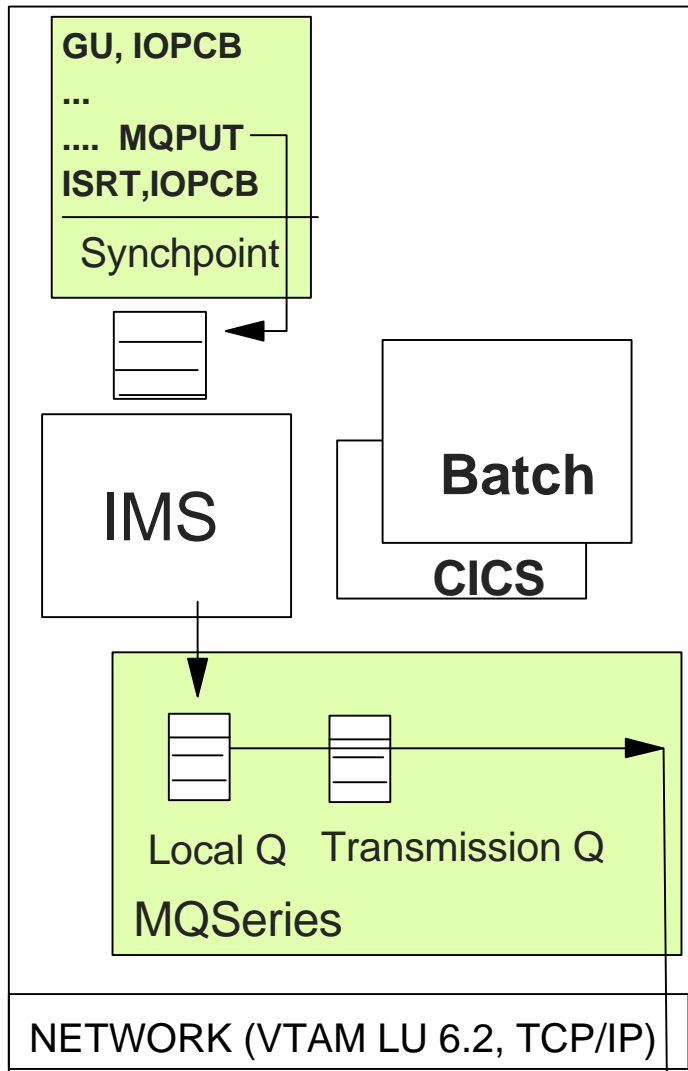

USES IMS
ESS Interface

- IMS commit is an MQ commit
- IMS backout is an MQ backout

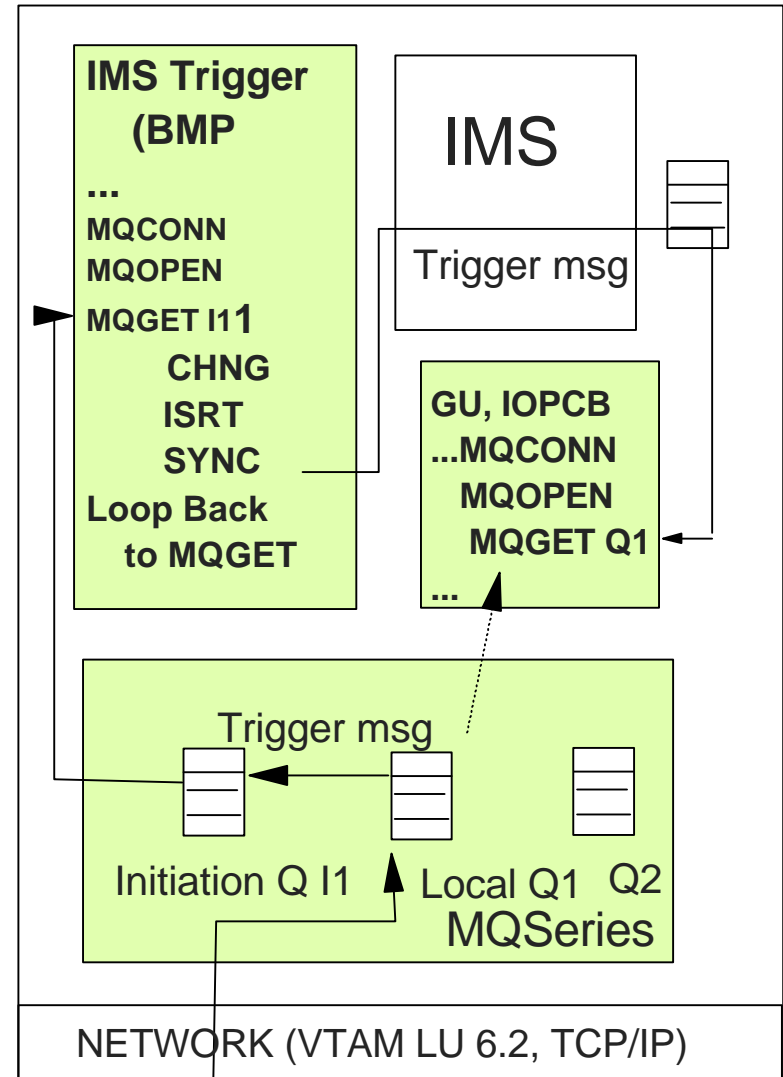

Connecting to IMS - - IMS Bridge

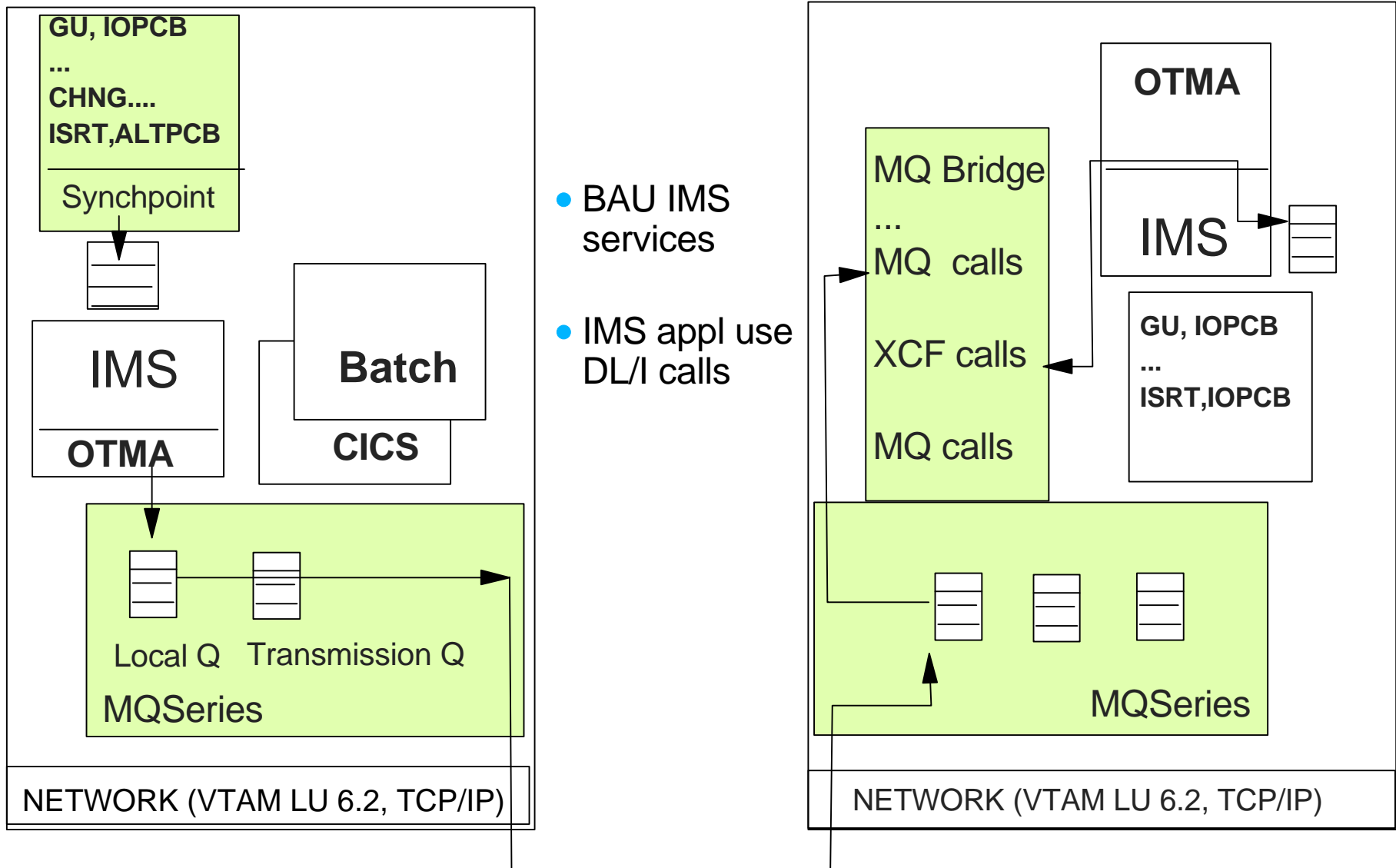

OTMA

OTMA Support

■ What is OTMA (Open Transaction Manager Access) ?

- ▶ Component of IMS/ESA V5
- ▶ Provides standard access into IMS from any MVS client
- ▶ Uses MVS Cross-System Coupling Facility (XCF) interface
 - Allows high performance cross-address space communications

IMS Control Region

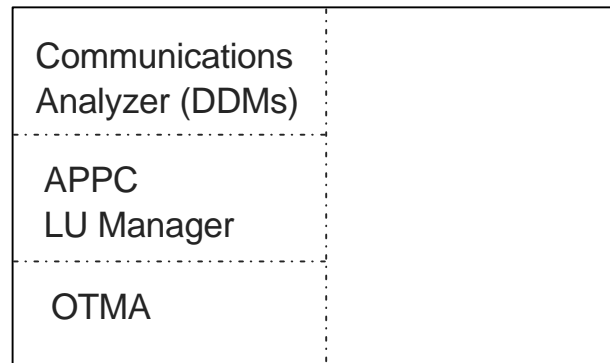

Answers Multiple Concerns

- **Product implementations can access IMS differently**
 - ▶ TCP/IP IMS Sockets
 - Listener BMP, Assist Module, Extended Sockets
 - Requires some change in the IMS application
 - ▶ AS/IMS
 - Interfaces with IMS using either LU 6.1 or LU 6.2 protocols
 - IMS applications can remain unchanged
 - ▶ MQSeries IMS Adapter
 - Trigger Monitor (BMP)
 - Requires MQ code in the IMS application
- **All impose some limitation on processing with IMS**
- **OTMA support provides a STANDARD interface**
 - ▶ BAU IMS services
 - ▶ Unchanged IMS applications

Comparisons

Comparisons

Transaction model Conversational Remote Procedure Call Messaging and Queuing

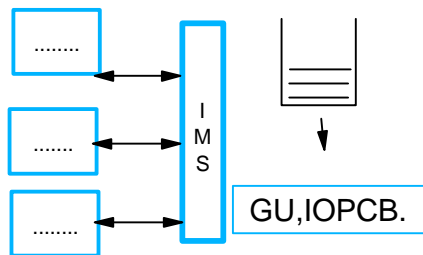

Client

Server

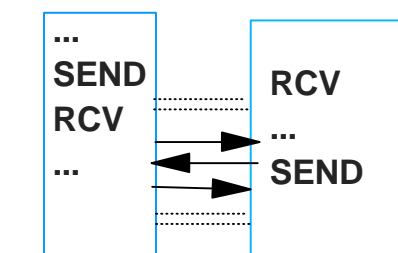

Client

Server

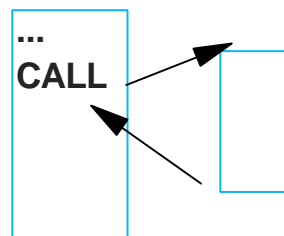

Client

Server

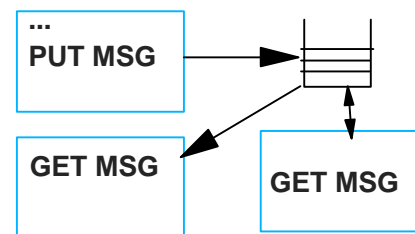

Client

Server

API:

LU Support

DL/I

CPIC

CPIC

RPC

RPC

MQI

MQI

APPC

APPC

DL/I

SOCKETSSOCKETS

DL/I

DL/I

SOFTWARE:

SNA
LU0,LU1,
LU2, LU4,
LU 6.1, LU6.2

VTAM
IMS

SNA
LU6.2

VTAM
APPC/MVS
IMS

MQSeries
SNA svcs

MQSeries
VTAM
IMS

TCP/IP
TELNET

TCP/IP
TELNET
IMS

TCP/IP
SOCKETS

MVS TCP/IP
IMS Sockets

DCE OE/ DCE
TCP/IP TCP/IP
VTAM
AS/IMS
IMS

MQSeries
TCP/IP

MQSeries
TCP/IP
IMS

Comparisons ...

Transactional

Conversational

Remote Procedure Call Messaging and Queuing

Characteristics:

- | | | | |
|--|--|---|--|
| <ul style="list-style-type: none"> ▶ Synchronous or asynchronous from the client ▶ Asynchronous from the server ▶ Protocols bridged by TP subsystem | <ul style="list-style-type: none"> ▶ Synchronous <ul style="list-style-type: none"> – Caller waits for reply ▶ Interactive <ul style="list-style-type: none"> – Multiple exchanges | <ul style="list-style-type: none"> ▶ Synchronous <ul style="list-style-type: none"> – Caller waits for reply – More limited than conversational model | <ul style="list-style-type: none"> ▶ Asynchronous <ul style="list-style-type: none"> – Sends message and does not wait for reply – Reply may be sent later |
|--|--|---|--|

Some basic comparisons:

- | | | | |
|---|---|--|--|
| <ul style="list-style-type: none"> ▶ Easiest to implement from the IMS appl perspective ▶ Proven over the years <ul style="list-style-type: none"> – Traditional – Familiar ▶ All communication flows executed by IMS <ul style="list-style-type: none"> – All IMS unique services applicable | <ul style="list-style-type: none"> ▶ Allows connectivity to client appl that are coded using APPC or Sockets ▶ Only way IMS appl can send a msg and wait for reply (explicit) ▶ Only way to support true conversations (explicit) ▶ Appl pgms include communication code <ul style="list-style-type: none"> – Appl design needs to include recovery | <ul style="list-style-type: none"> ▶ Supports an industry open interface and standard services <ul style="list-style-type: none"> – DCE as defined by OSF ▶ Allows appl to be shielded from communication flow ▶ Server environment needs to create IDL interface definitions for the server appl | <ul style="list-style-type: none"> ▶ Supports a standard API across SNA and TCP/IP environments ▶ Supports message routing, delivery and recovery across platforms <ul style="list-style-type: none"> – Requires MQSeries set of products ▶ Also allows applications to be shielded from communications |
|---|---|--|--|

The Web Environment

The Web -- What is it

- **Another Client/Server Application in the TCP/IP stack**
 - ▶ Uses HTTP (Hypertext Transfer Protocol)

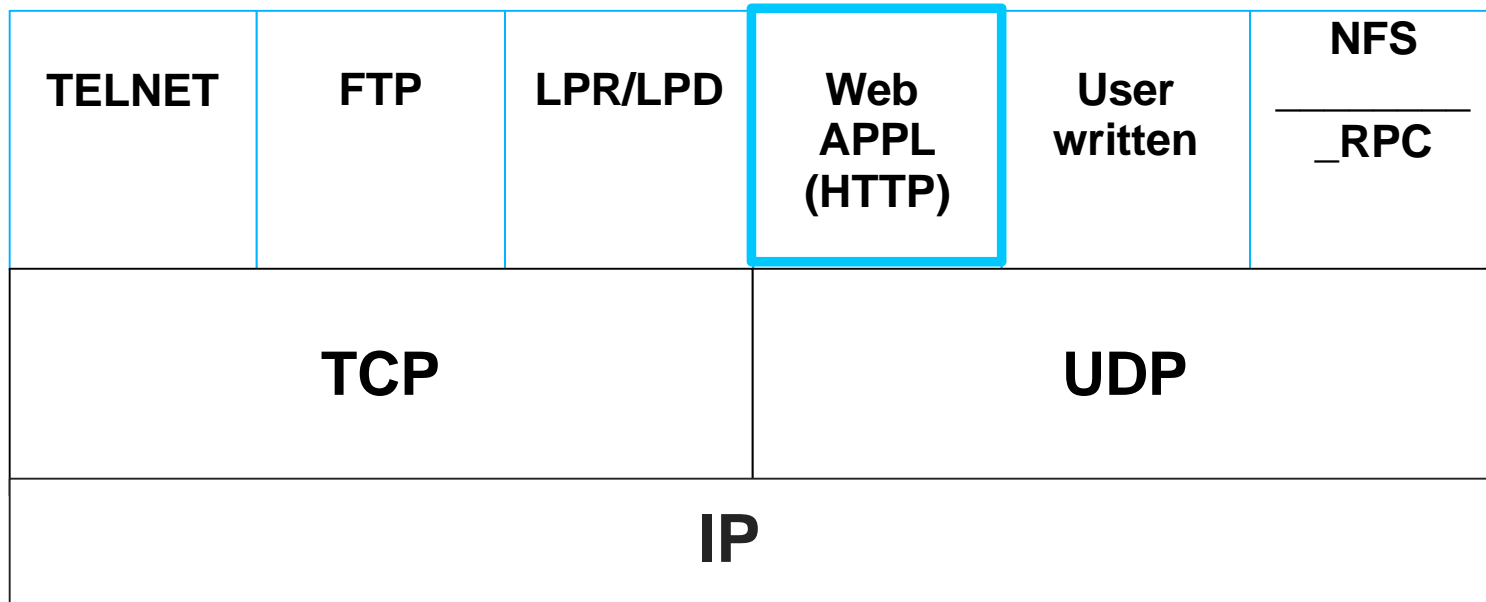

History of the Web

- **Originated in 1989 at CERN (European Particle Physics Laboratory) in Geneva, Switzerland by Tim Berners-Lee**
 - ▶ Purpose was to create a new kind of information system
 - Allow researchers to collaborate and exchange information during the life of a project or on several projects
 - First browser was a line-mode browser
- **In 1993 Mosaic was released based upon work done by Mark Andreessen at the NCSA (National Center for Supercomputing Applications)**
 - ▶ Mosaic is a WEB browser with an easy-to-use interface that allows the user to click on a link to navigate the Web as well as the ability to display graphics
 - ▶ The advent of Mosaic initiated the widespread appeal of the Web
- **Since then the Web has extended beyond the scientific and educational community to the commercial and home environments**
 - ▶ Variety of Web browsers, servers and applications

Terminology

■ **Web Browser**

- ▶ The client part of the client/server application
 - Takes the user's request
 - Sends it to the server
 - Retrieves the document sent by the server
 - Interprets the contents
 - Presents it to the user

■ **Web Server**

- ▶ The other half of the client/server model
 - Holds documents
 - Responds to browser requests
- ▶ Supports text and multimedia documents
- ▶ Executes special programs
 - Can act as a gateway to other applications or information resources

Terminology ...

■ HTTP (Hypertext Transfer Protocol)

- ▶ Method for encapsulating a variety of data types in a common format
- ▶ Protocol used by web browser and server applications to communicate
 - Lightweight stateless protocol
 - Each document request is a new connection

■ HTML (Hypertext Markup Language)

- ▶ Special tagging language used in ASCII (plain text) documents
 - Tells Web browsers how to format Web pages
 - Describes the structure of a document but not its exact formatting
 - Exact format (way it looks to the user) depends on the browser
- ▶ Provides the ability to imbed hypertext links in documents
 - A hypertext link is identified with a special tag

■ Hypertext Link

- ▶ Capability to allow one document to reference another
- ▶ Links can span computers around the world

Terminology ...

■ URL (Uniform Resource Locator)

- ▶ A unique address for a specific document on the Web

http://www.company.com/ABC/menu.html

application server name path to the document protocol

■ CGI (Common Gateway Interface)

- ▶ Facility to create applications that can be invoked by the Web server
 - Special HTML form
 - Can contain input fields, lists for the user to select from, buttons for the user to click, etc...

The Web Application

http://www.company.com/menu.html

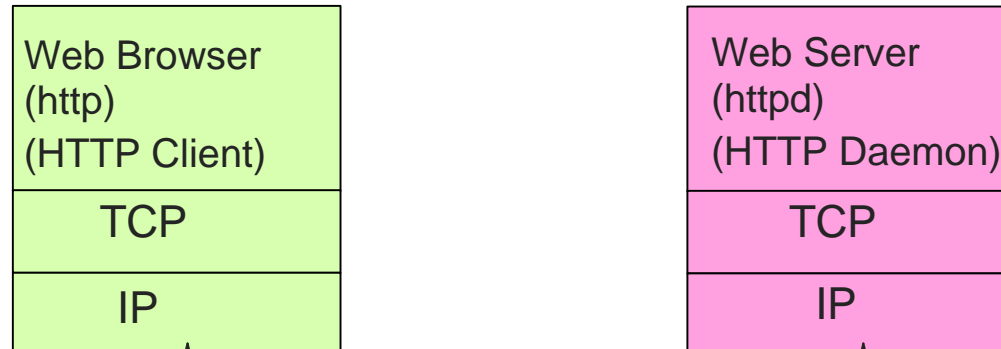

Listens on Port 80 unless otherwise defined

Client Request (Http request: GET....)

Http header plus the document

Client Request:

Server Response

Method + URL

GET ../menu.html

HTTP/1.0 200 OK
 Date: Wednesday, 02-26-97..
 Server: Website/1.1
 Last Modified: Tuesday, 02-25
 Content-type:text/html
 Content-length:8151
 ...
 <HTML><HEAD>
 <TITLE> Menu </TITLE>
 ...

HTML header:

Types of docs the client can accept

ACCEPT: image/gif, image/jpeg
 ..

Version, status,reason

Date

Server software info...

Info on doc modif.

Type of data returned

Size

Document itself

Name/version of client software

User-Agent: Mozilla/2.0n (Windows..)

Web Components - A Closer Look

Web Flow

End users specify a URL to access a document

■ **http://server-name:port-number/path-name/file-name**

■ **Examples:**

▶ http://www.ibm.com

▶ http://www.software.ibm.com/data/ims

▶ http://www.s390.ibm.com

▶ http://postcards.www.media.mit.edu/postcards

■ **Default file name is usually index.htm or index.html**

■ **Default TCP/IP port number for http is 80**

Web Flow...

The URL can reference a document (text only) created using HTML

```
< html > < head >  
< title > This is the title line < /title >  
< /head >  
< body >  
< h1 > This is a heading < /h1 >  
< h2 > This is another heading < /h2 >  
< ul > < li > This is an item in an un-ordered list < /ul >  
< ol > < li > This is an item in an ordered list < /ol >  
< a href = "http://www.software.ibm.com/data/ims" >  
This is a link to IMS home page< /a >  
< a href = "ftp://www.s390.ibm.com" > This is a link to the IBM S/390  
server < /a >  
< img src = "pic1.gif" > < p > This img tag includes a picture in the  
page  
< a href = "pic2.gif" > This is a link to a picture < /a >  
< /body >  
< /html >
```

Web Flow...

The URL can also access a special form that is not just a text document but allows interaction

■ Web forms were introduced to help support end user input

- ▶ Forms programming provides an architected mechanism to allow browsers to pass data to a server
 - A way to support transaction processing

■ Example

- ▶ End user enters a URL at the browser
- ▶ The request is passed to the server which sends the form corresponding to the request
 - Form can be generated dynamically by a CGI script
 - Or, it can be a predefined form that is simply retrieved by the server
- ▶ The end user enters required data on the form displayed by the browser
- ▶ The data is passed back to the server
- ▶ The CGI script encoded in the form is invoked by the server to process the input received

Web Flow...

A little more about this Web Form ...

- ▶ **An HTML page can contain a number of forms**
- ▶ **Each form has a tag (FORM ACTION = "url") which can determine the name of the script that processes the form**
- ▶ **Each form has any number of input tags that name input fields and associated values**
- ▶ **The forms programmer:**
 - Builds the output page dynamically in order to supply variable output data
 - Places an indication of the next program to be executed in the FORMS ACTION tag
 - Saves context across invocations in the form itself, e.g. in a hidden field (the Web server is stateless)
- ▶ **In a multi-user environment, the forms programmer:**
 - Takes care naming any intermediate files created so they do not coincide across different users
 - Places hidden information in the form that distinguishes the various users from one another

Web Flow...

The CGI program can work with the data on the web form as well as execute any programming function including communication calls to a backend server like IMS

- **Method - GET or POST**
- **Action - Names the program to be executed**
- **Environment Variables**
 - Server dependent, e.g. name and version of server, server name
 - Client dependent, e.g. request method (GET or POST), the client hostname, path information
- **Input - stdin**
- **Output - stdout, HTML page**
- **cgiutils**
- **cgiparse**

Accessing IMS

Accessing IMS

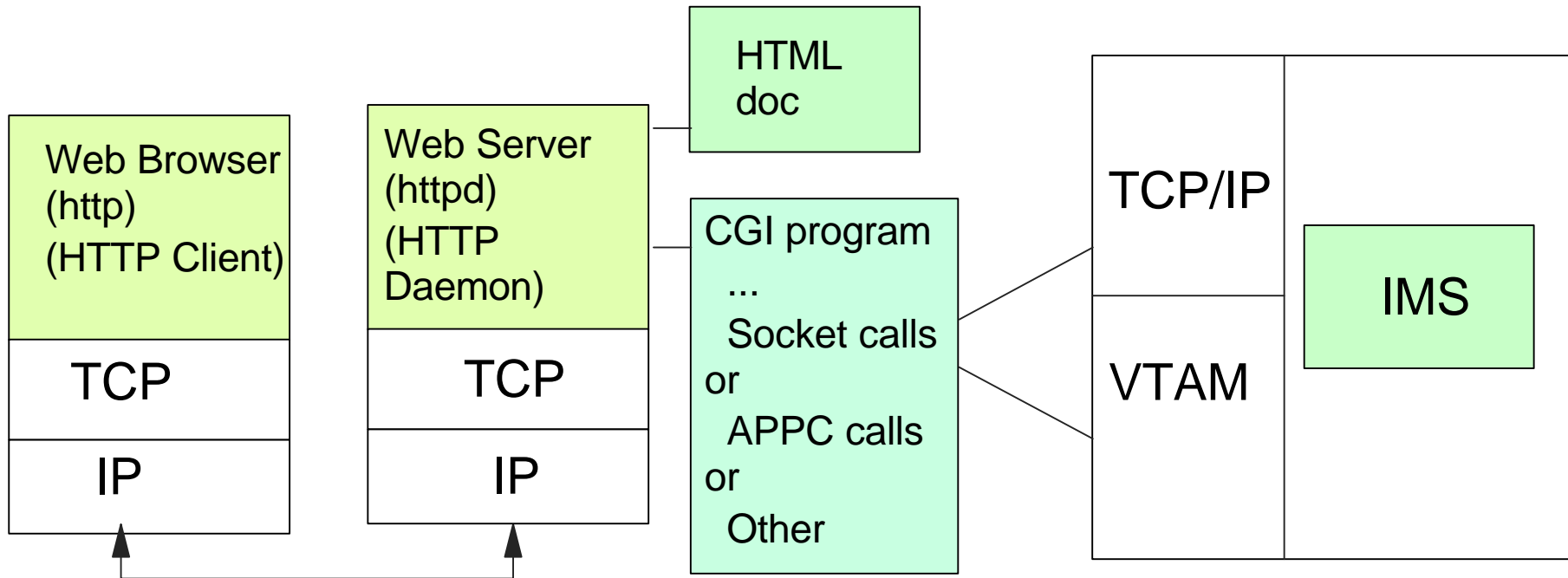

Web Browser
Understands
HTML and
HTTP

Web Server
Provides HTML
docs and CGI
programs

CGI Programs

1. Access IMS using any supported protocol
2. Convert transaction input/output to HTML

Accessing IMS...

The CGI program can access IMS in several ways depending on the environment and network

- **SNA**

- ▶ LU0 (SLUP), LU1, LU2, LU 6.1(ISC), LU 6.2 (APPC)
- ▶ MQ

- **TCP/IP**

- ▶ 3270 emulation (e.g., HCON HLLAPI, Telnet,...), Sockets
- ▶ MQ

- **DCE**

- ▶ RPC (Remote Procedure Calls)

The IMS application does not have to be changed

Security Considerations

■ Firewalls - first line of defense

- ▶ Combination of hardware/software used to protect one network from another
- ▶ Provide a limited entry point to/from a secure network
- ▶ Firewalls can use a combination of several technologies
 - Packet Filters
 - Proxy Servers or Application Gateways
 - Socks (Internet Socket Service)
 - Network Address Translation, IP Tunneling, etc...

■ Web Specifics - Second line of defense

- ▶ Basic Authentication
- ▶ SSL (Secure Socket Layer)
- ▶ S-HTTP (Secure HTTP)
- ▶ Secure Commerce

■ IMS considerations - the final protection

- ▶ IMS security
- ▶ IMS application security

IMS and the Web --What's available?

IMS Solutions

- **IMS information is available on the Internet**

- <http://www.software.ibm.com/data/ims>

- ▶ Documentation
- ▶ IMS WWW templates (sample CGI applications)
 - Link to OS/ 390 Internet Bonus Pak II (IMS CGI sample)
 - IMS Sample CGI program
- ▶ IMS WEB
 - Web Studio - Development toolkit
 - DLLs
 - Host component - OTMA
- ▶ Sample Java application



Summary

- **IMS supports a wide variety of solutions that allow access to IMS from the Internet with**

- **Consistency**
- **Flexibility**
- **High performance**

