

RACF and the Parallel Sysplex

Vanguard EXPO 2003

**July 13-17, 2003
Orlando Florida**

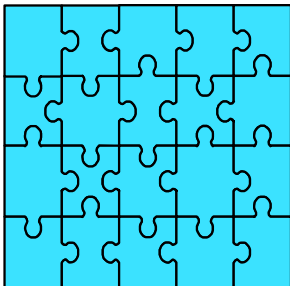

**Russ Hardgrove
RACF Level 2 Team Leader
IBM - OS/390 & z/OS Software Service
Poughkeepsie, NY 12601
hardgrov@us.ibm.com**

Objectives:

- Understand the Sysplex Environment
- Implement RACF Sysplex Communication
- Implement RACF Sysplex Data Sharing
- Understand the Recovery Modes available
- Describe the steps to define the Coupling Facility Policy for RACF

RACF Sysplex Support Objectives

Performance

- Reduce Contention for RACF Database

System Management

- Provide Single-System Image for Security Administration

Availability

- Propagate RVAR Y to ALL Systems that Share the RACF Database
- Minimize Sympathy Sickness

Overview - How It Works

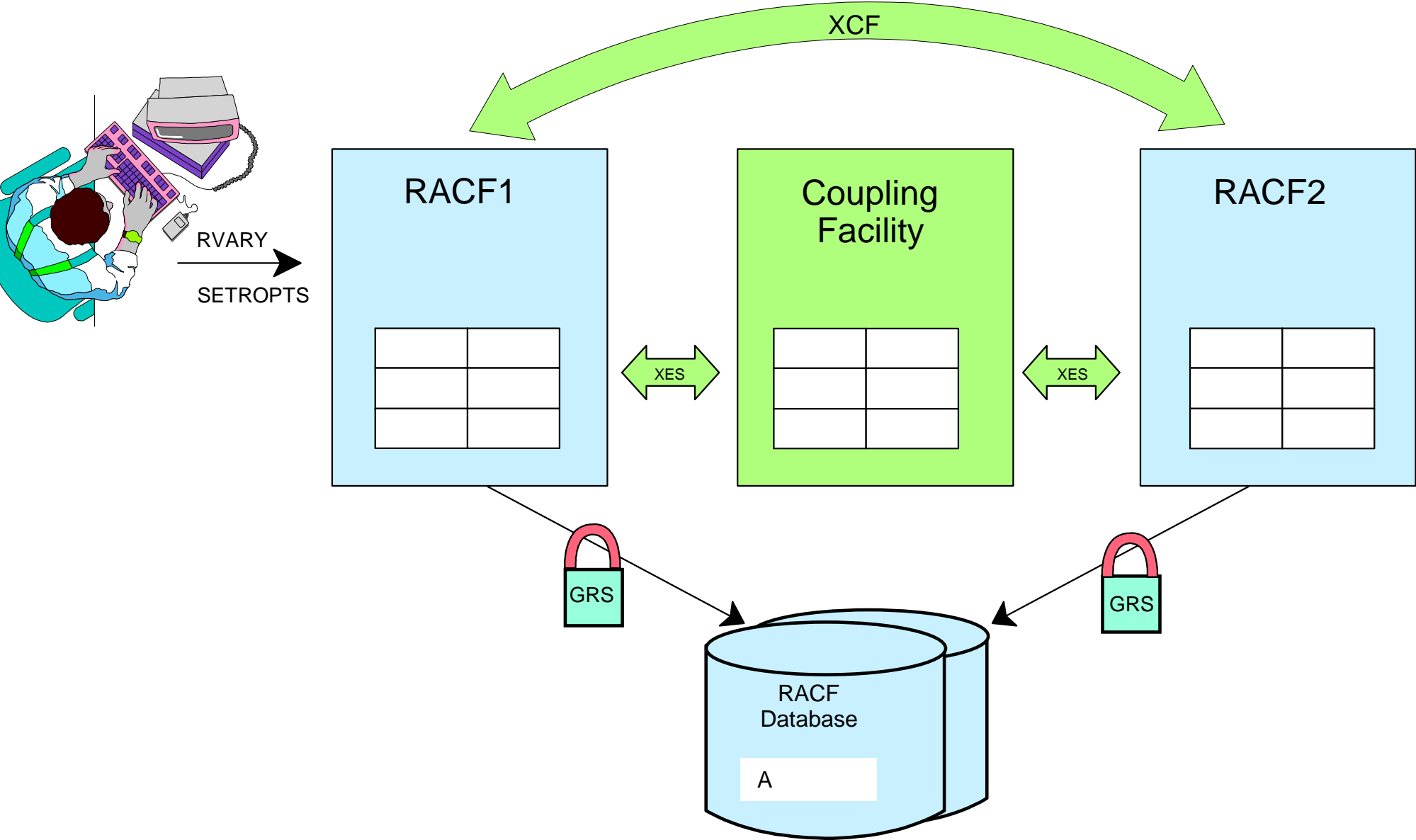

Requirements

RACF Sysplex Communication

- Sysplex capable via CTC
- all software levels supported

RACF Sysplex Data Sharing

- Parallel Sysplex capable with CFs
- all software levels supported

What Is a Sysplex?

Sysplex
Timer

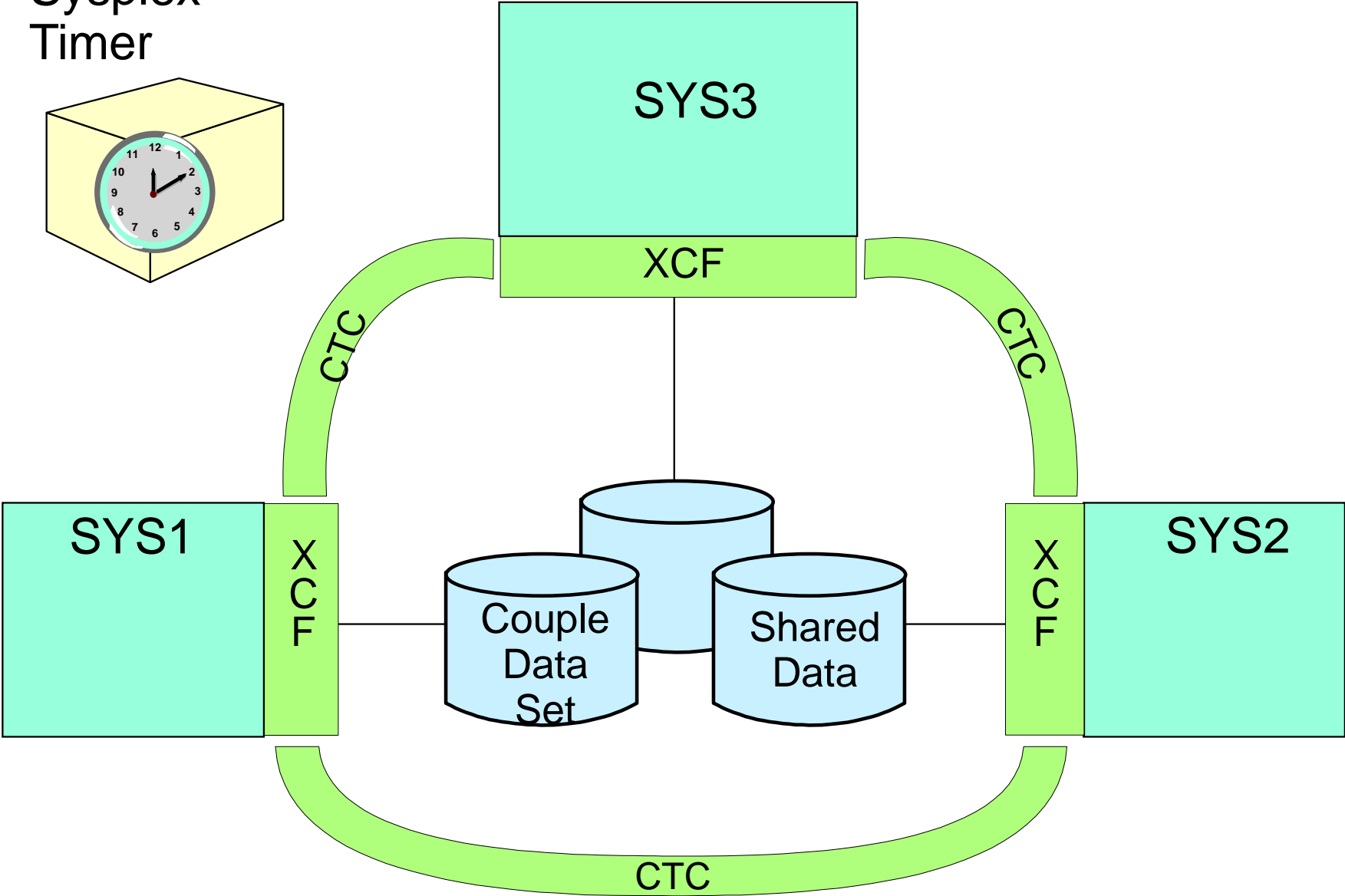
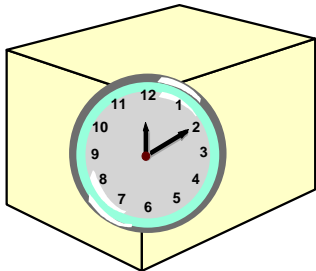

Sysplex Terminology

- Sysplex
- Multisystem Application
- Member
- Group
- Couple Data Set



Cross-System Coupling Facility (XCF)

Group Services

- define groups and members

Signalling Services

- communication among members

Monitoring Services

- status of systems

Time Services

- synchronized time

Sysplex with a Coupling Facility

Sysplex
Timer

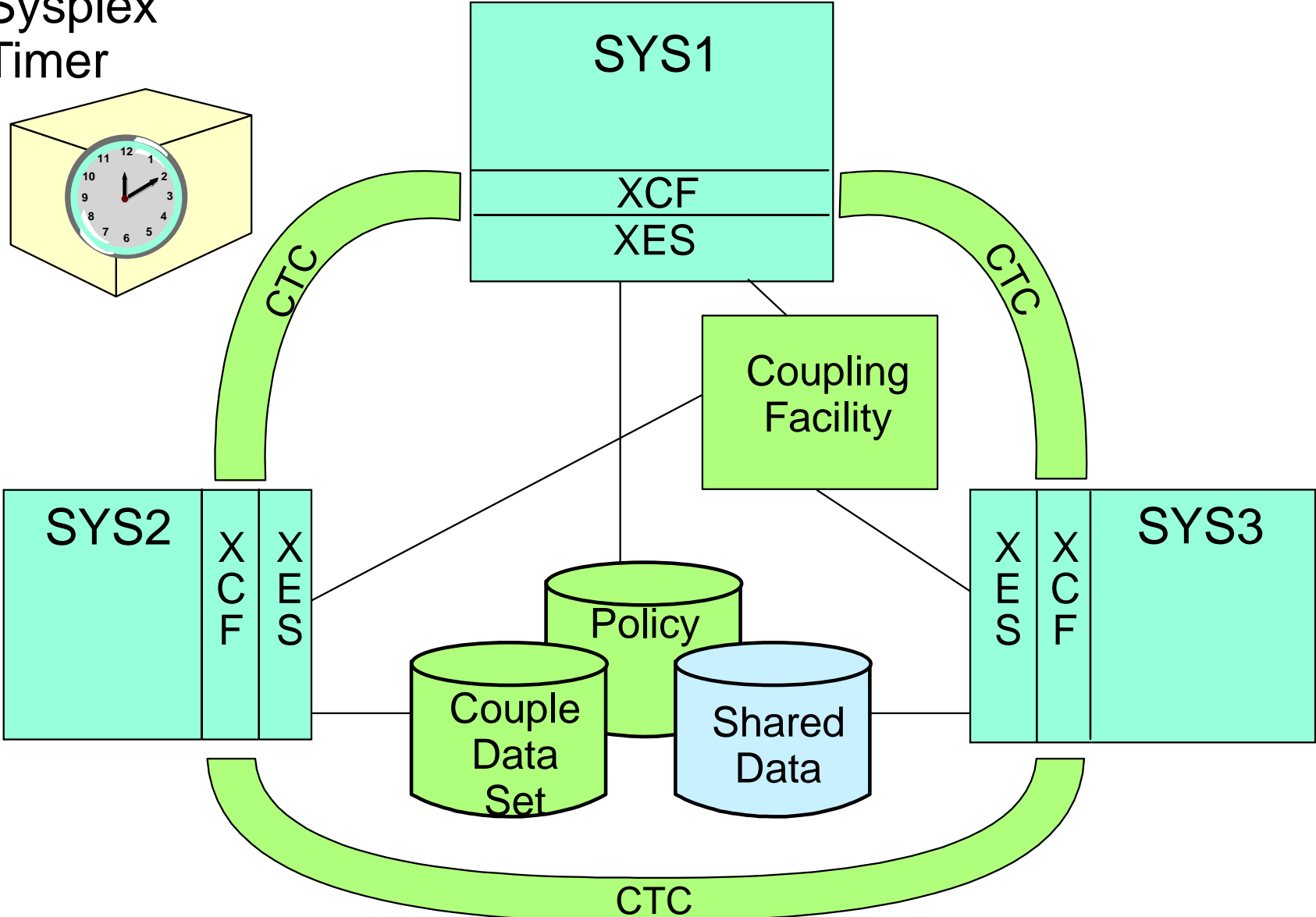
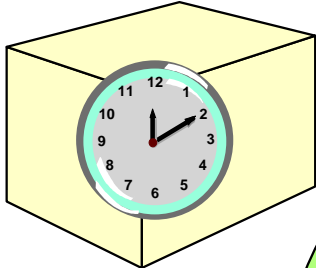

Coupling Facility

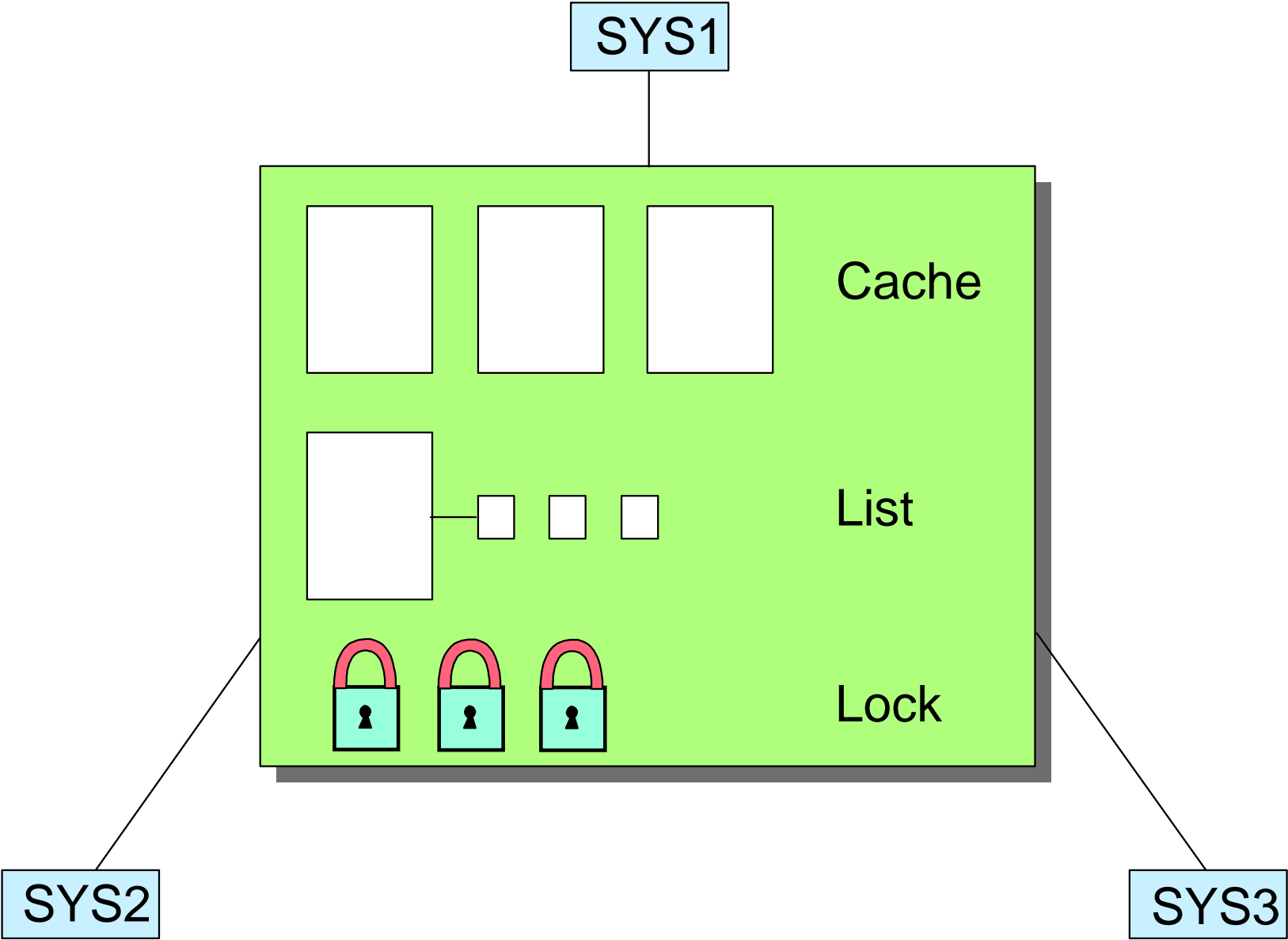

Cross-System Extended Services (XES)

- Connection Services
- Connection Recovery Services
- Application Mainline Services
- Measurement Services
- Dumping Services

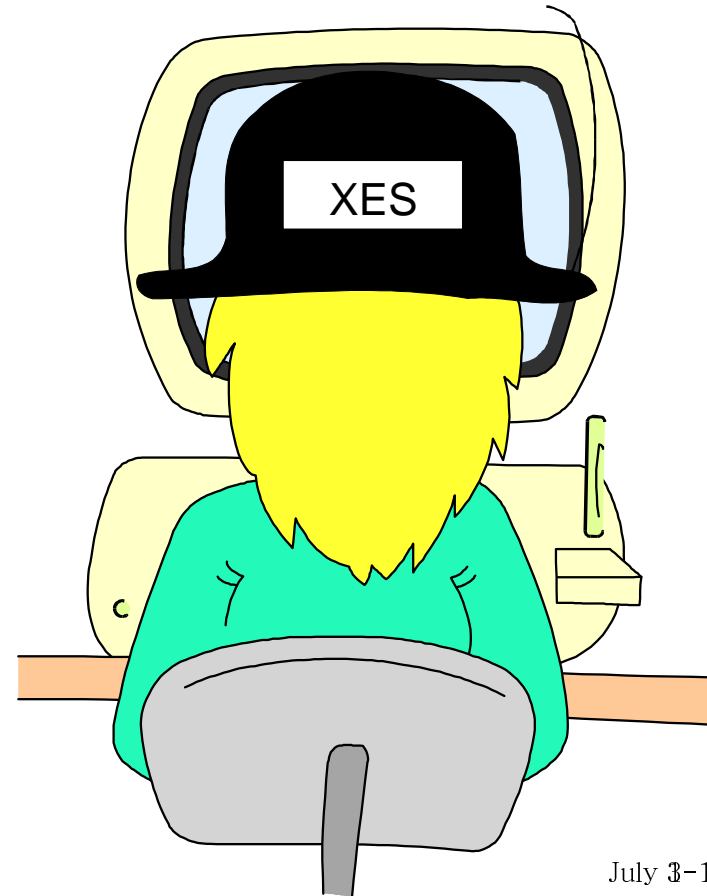

RACF Data Sharing Group

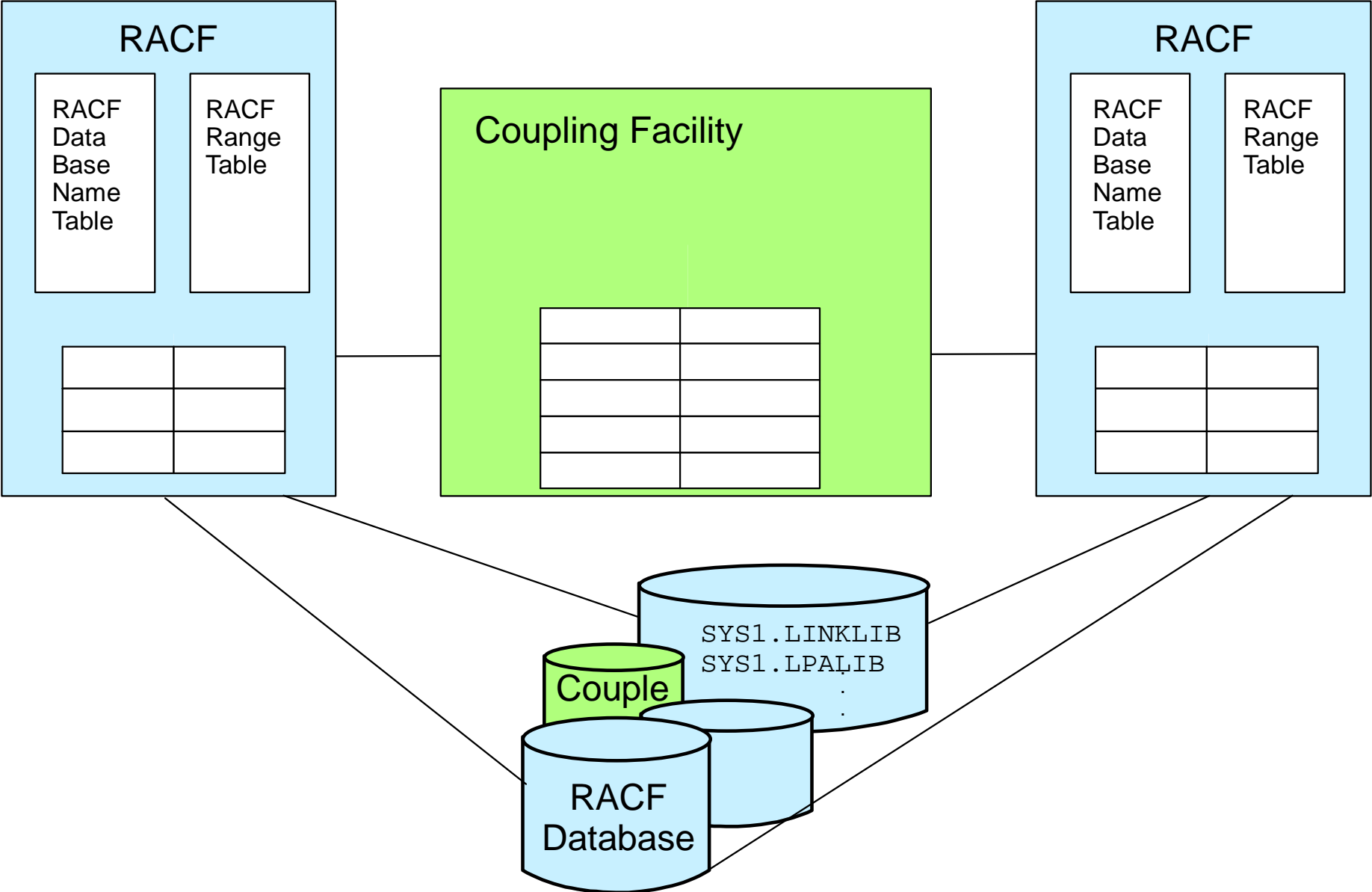

RACF Tables

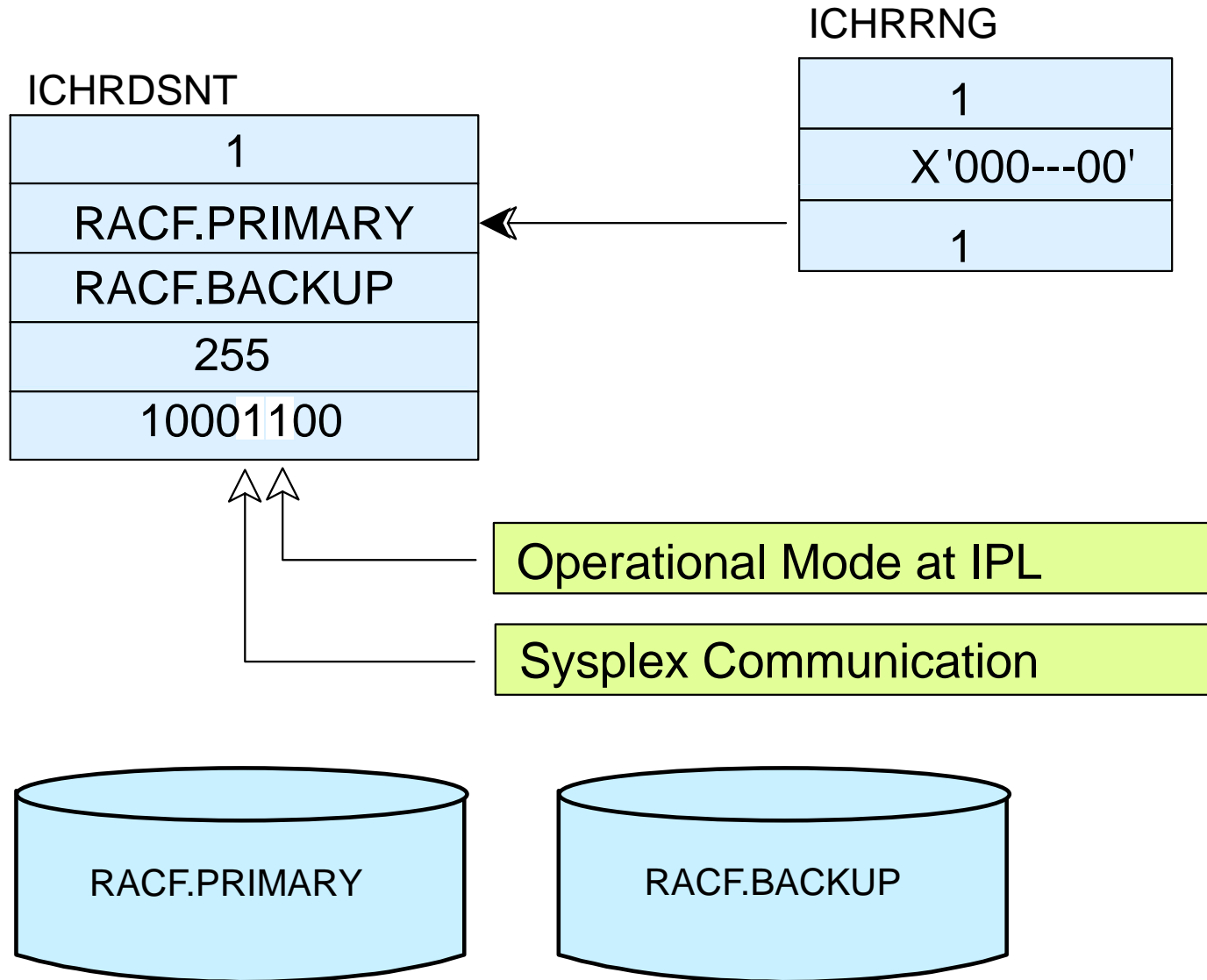

Multiple RACF Databases

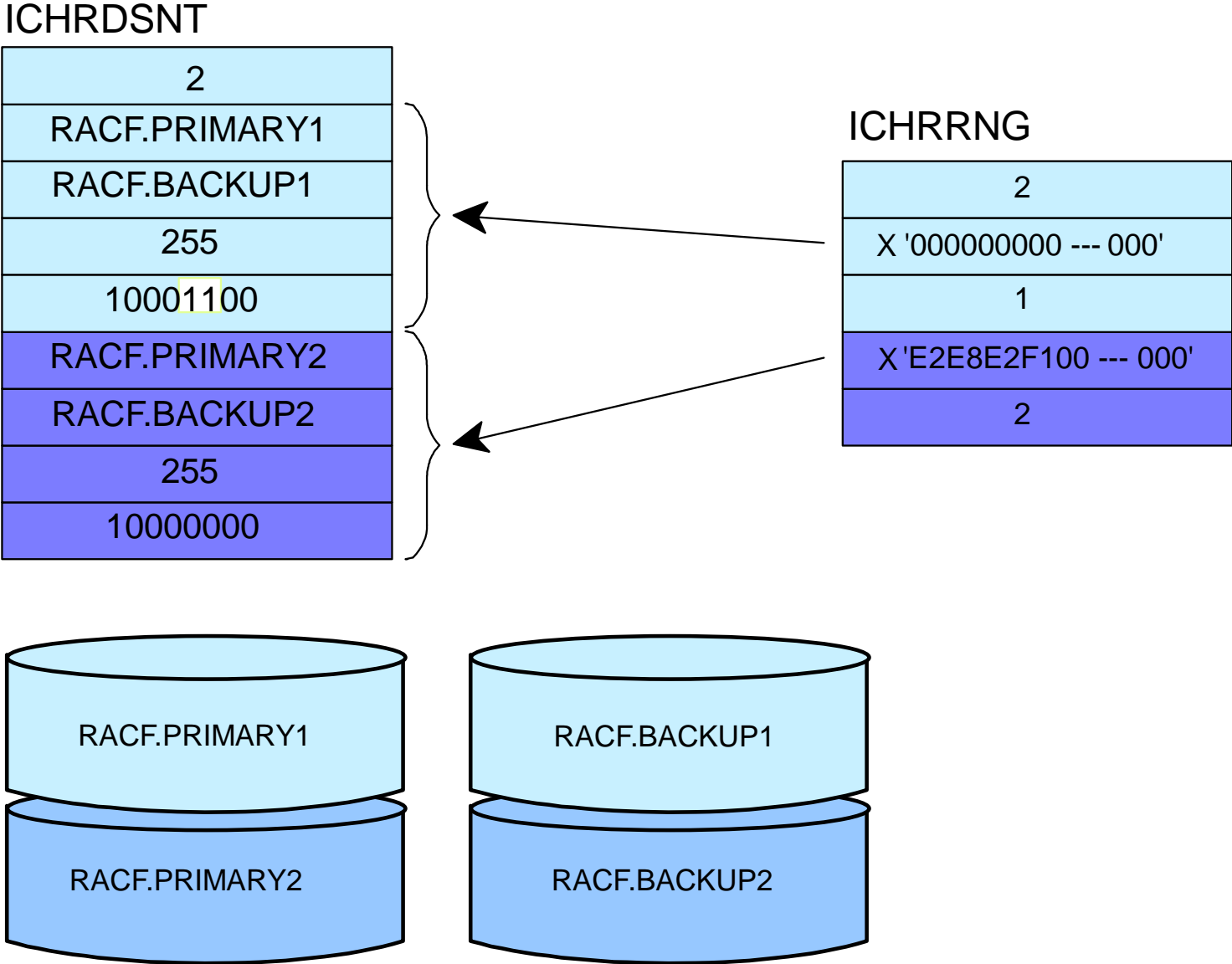

Command Propagation

RVARY

ACTIVE

INACTIVE

SWITCH

DATASHARE

NODATASHARE

SETROPTS

RACLIST

RACLIST REFRESH

NORACLIST

GLOBAL

GLOBAL REFRESH

GENERIC REFRESH

WHEN(PROGRAM)

WHEN(PROGRAM) REFRESH

RACF Tables

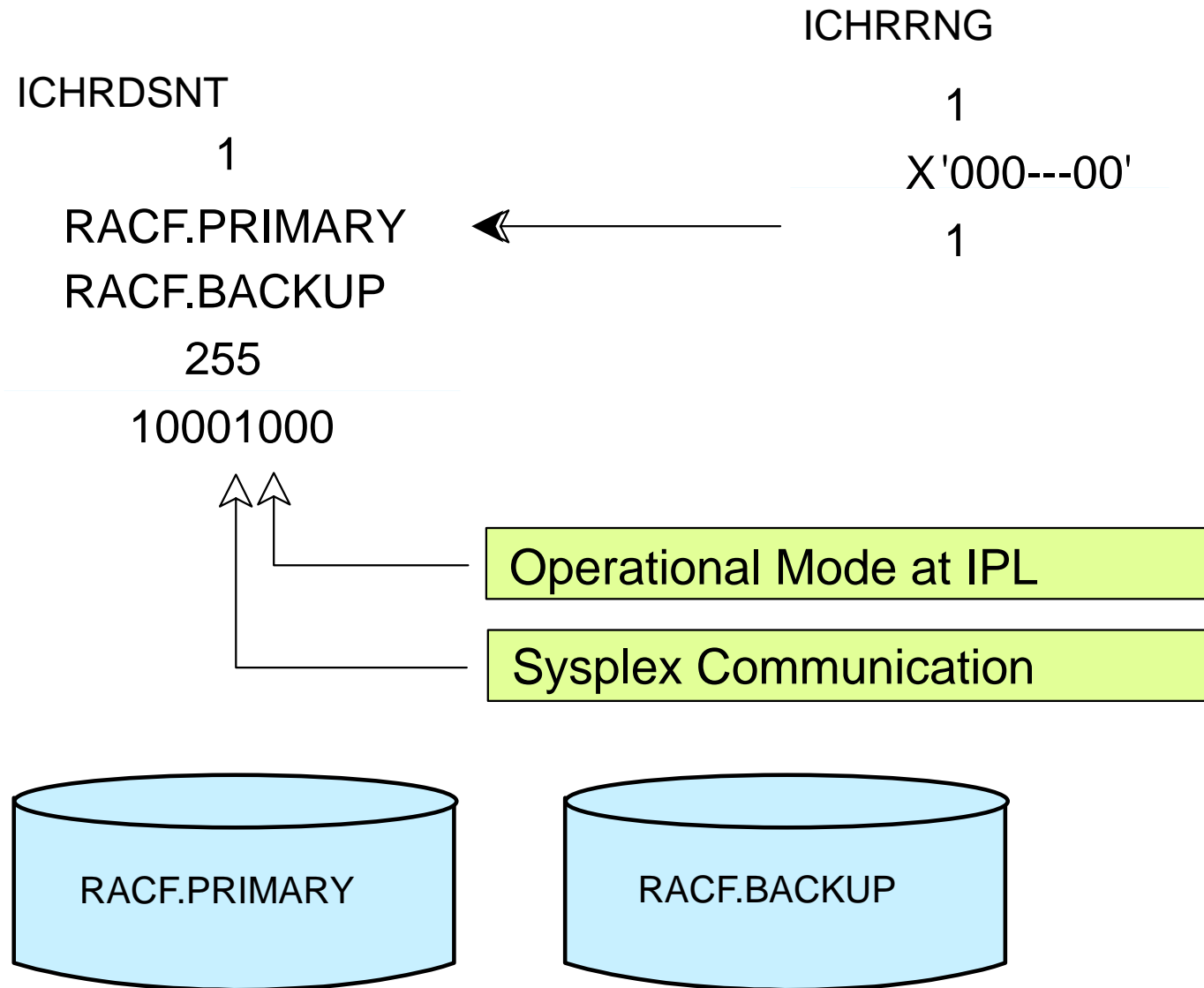

RVARY and SETROPTS Command Propagation

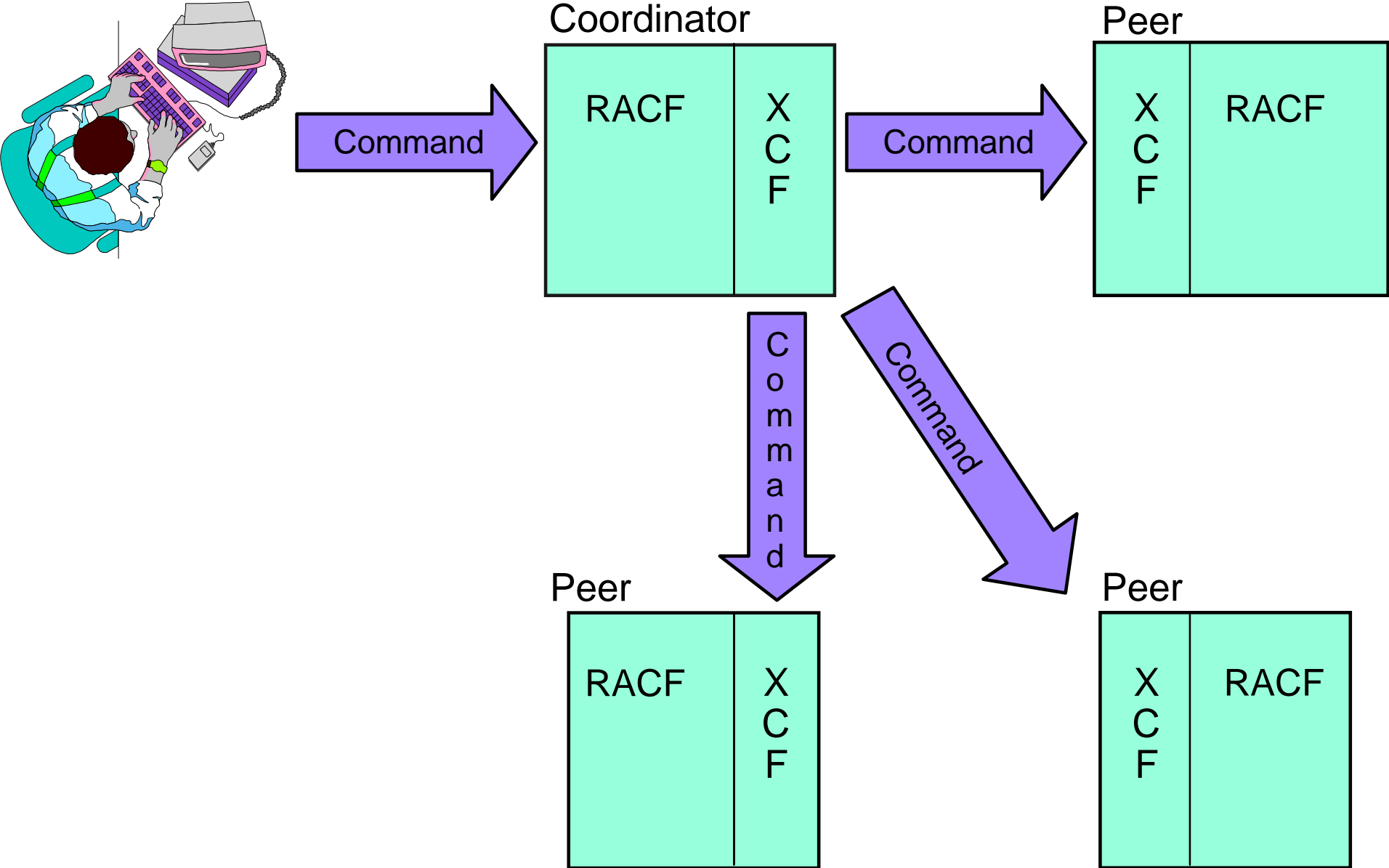

Command Propagation Processing

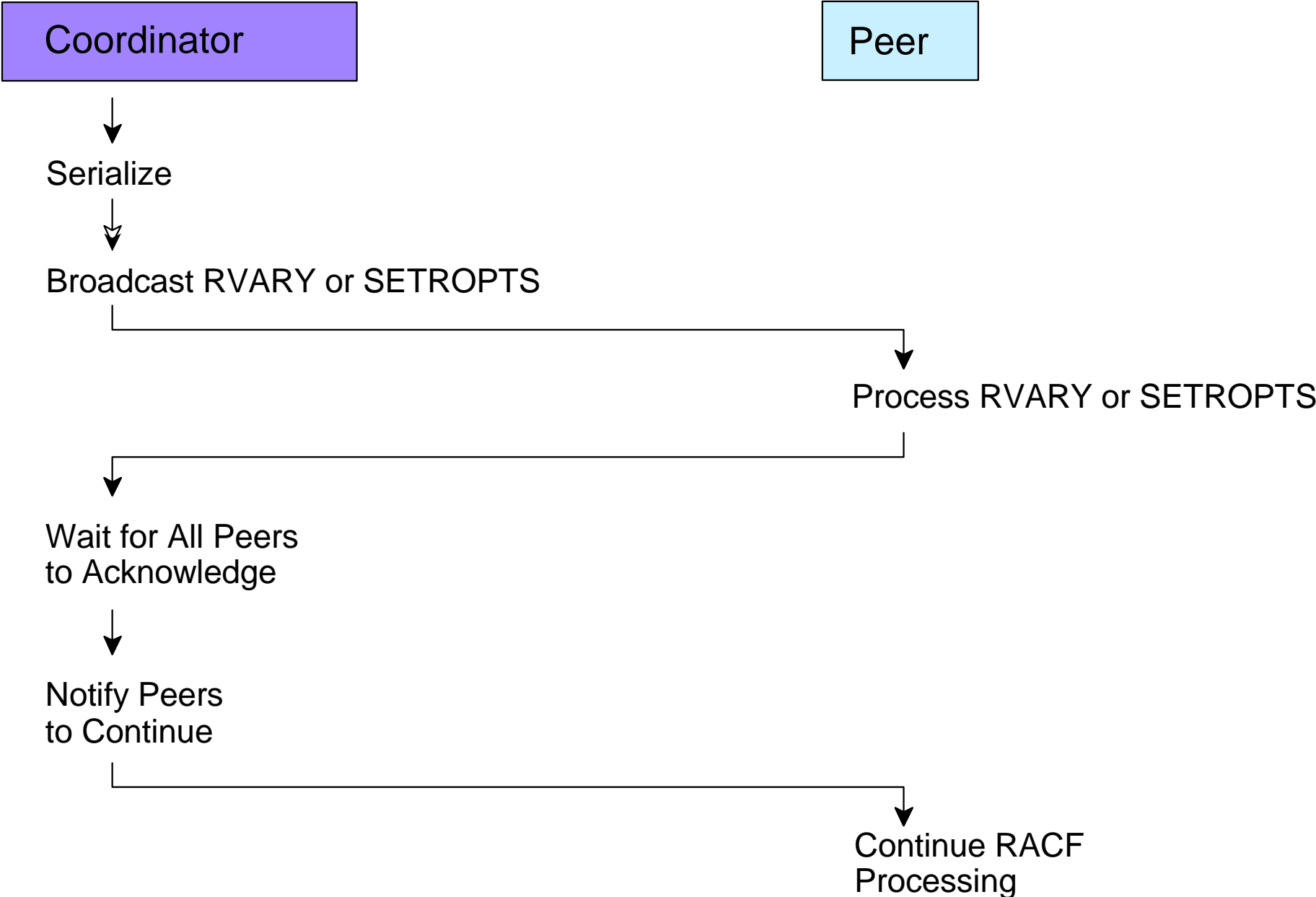

MVS Command Prefix Facility

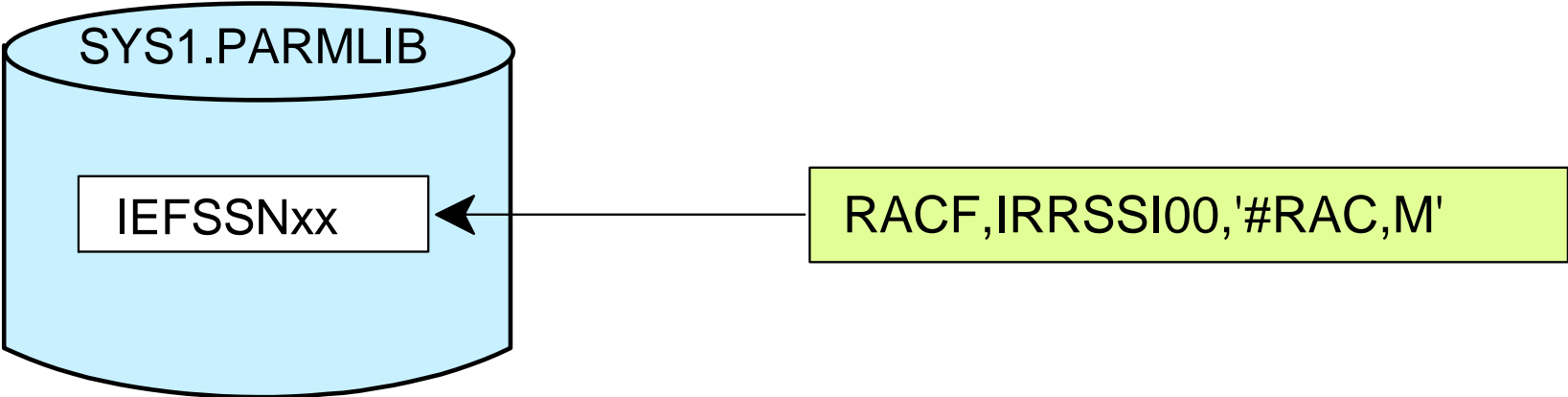
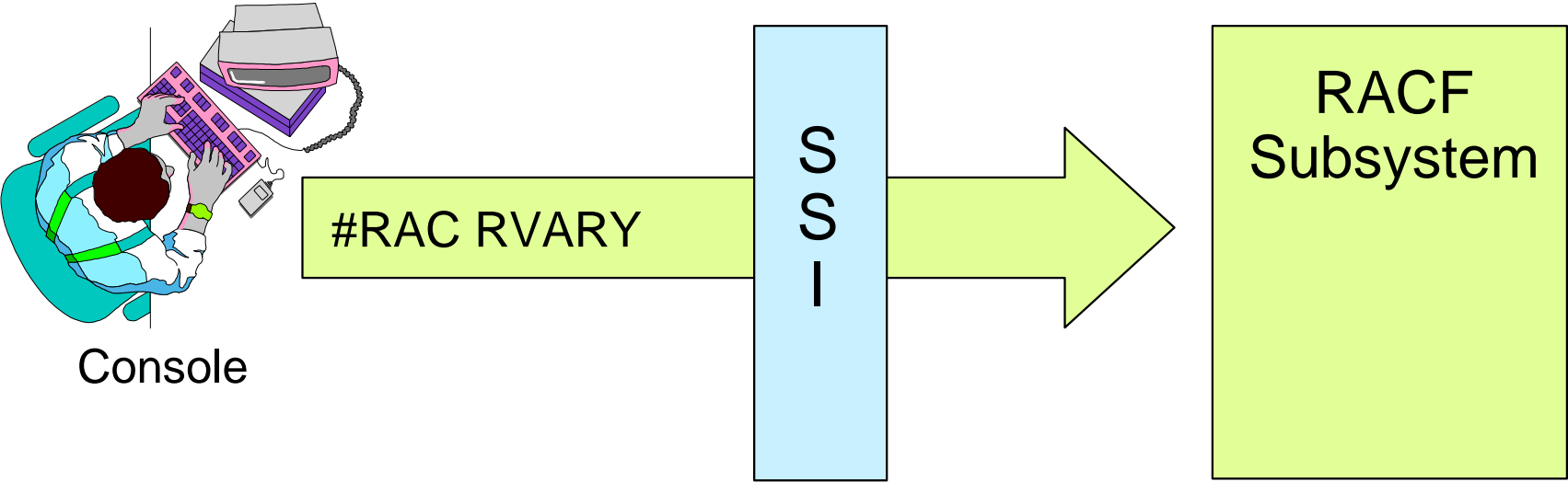

Conceptual View of Cache

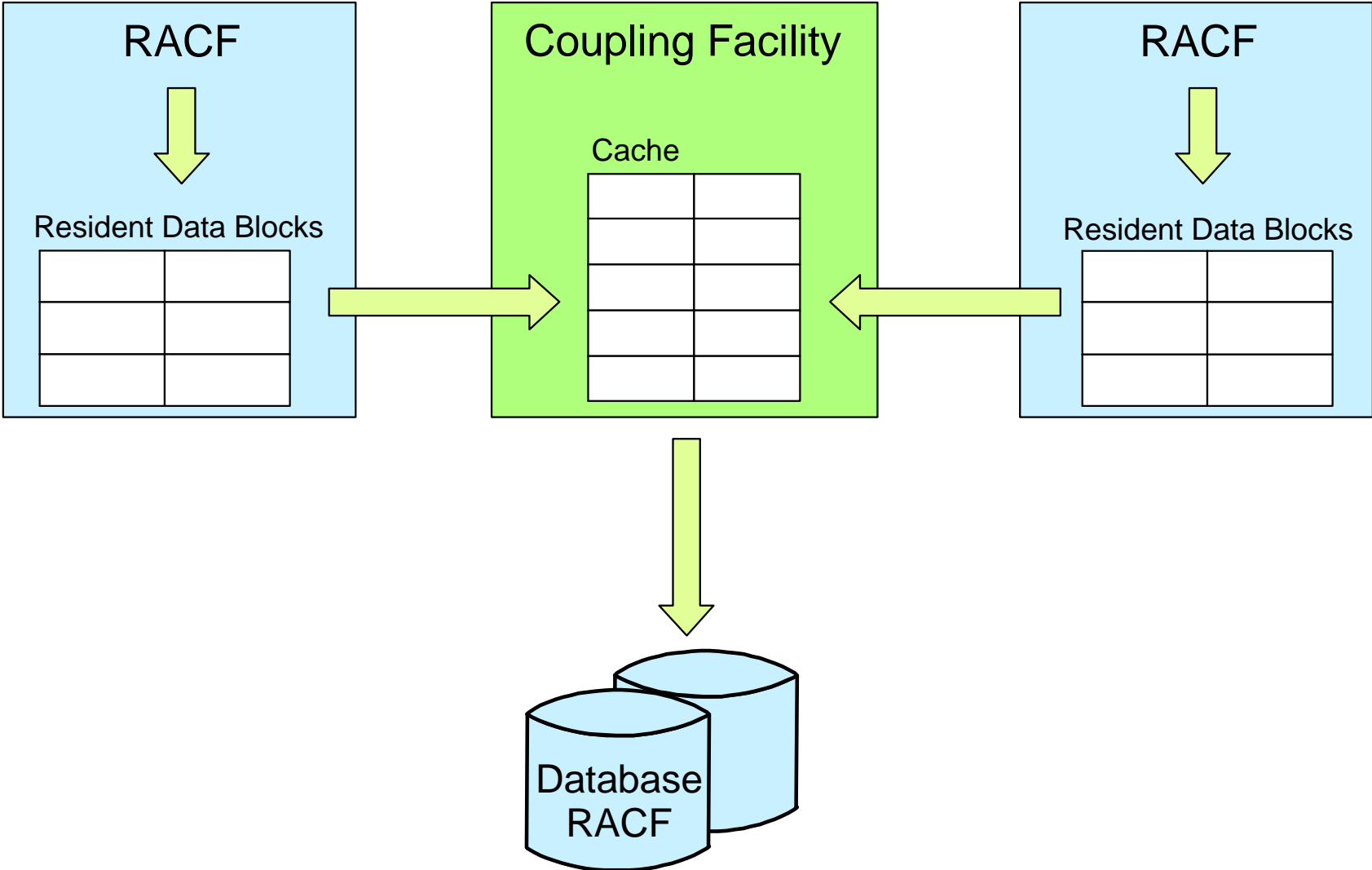

RACF Use of Coupling Facility - Read

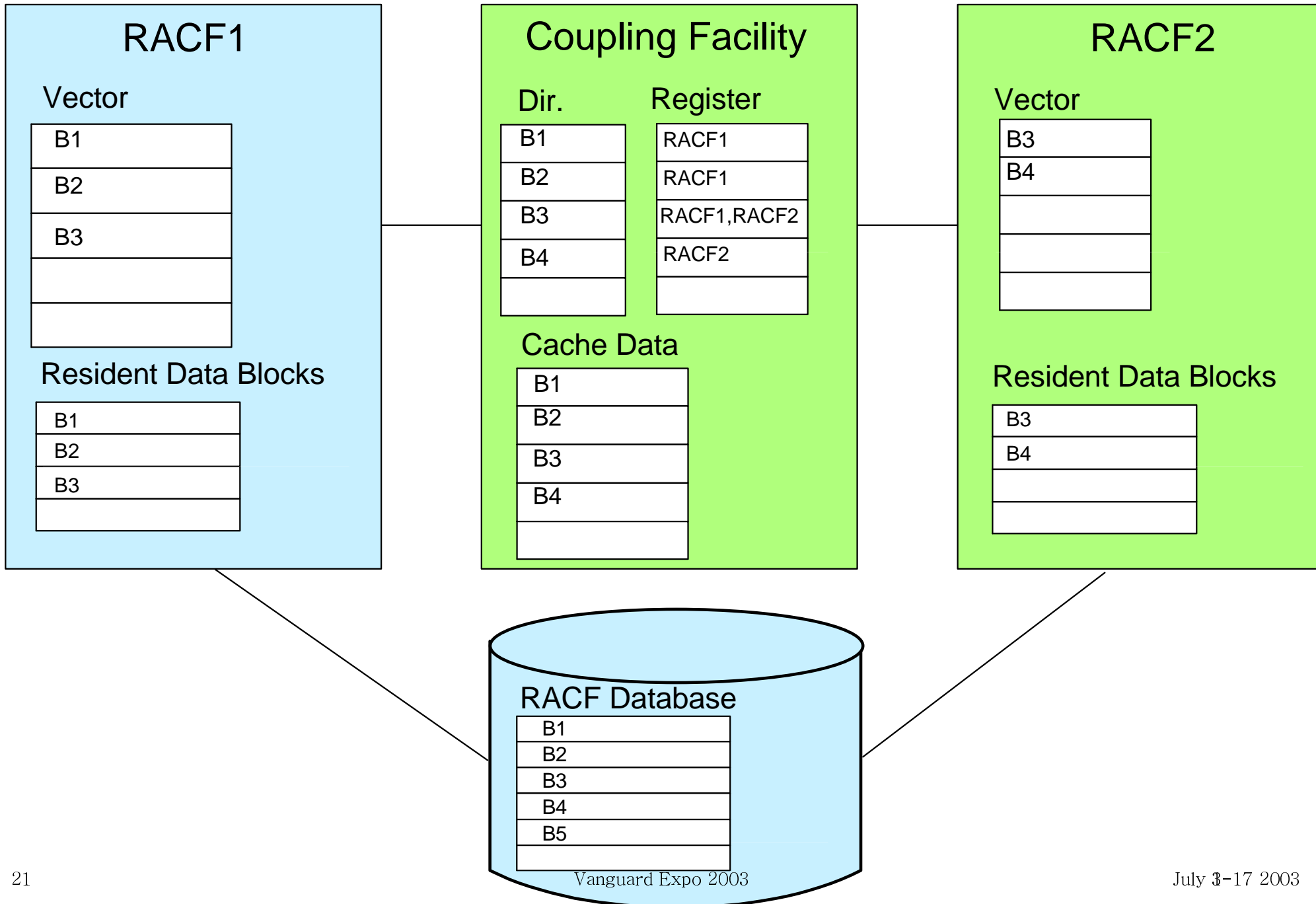

RACF Use of Coupling Facility - Write

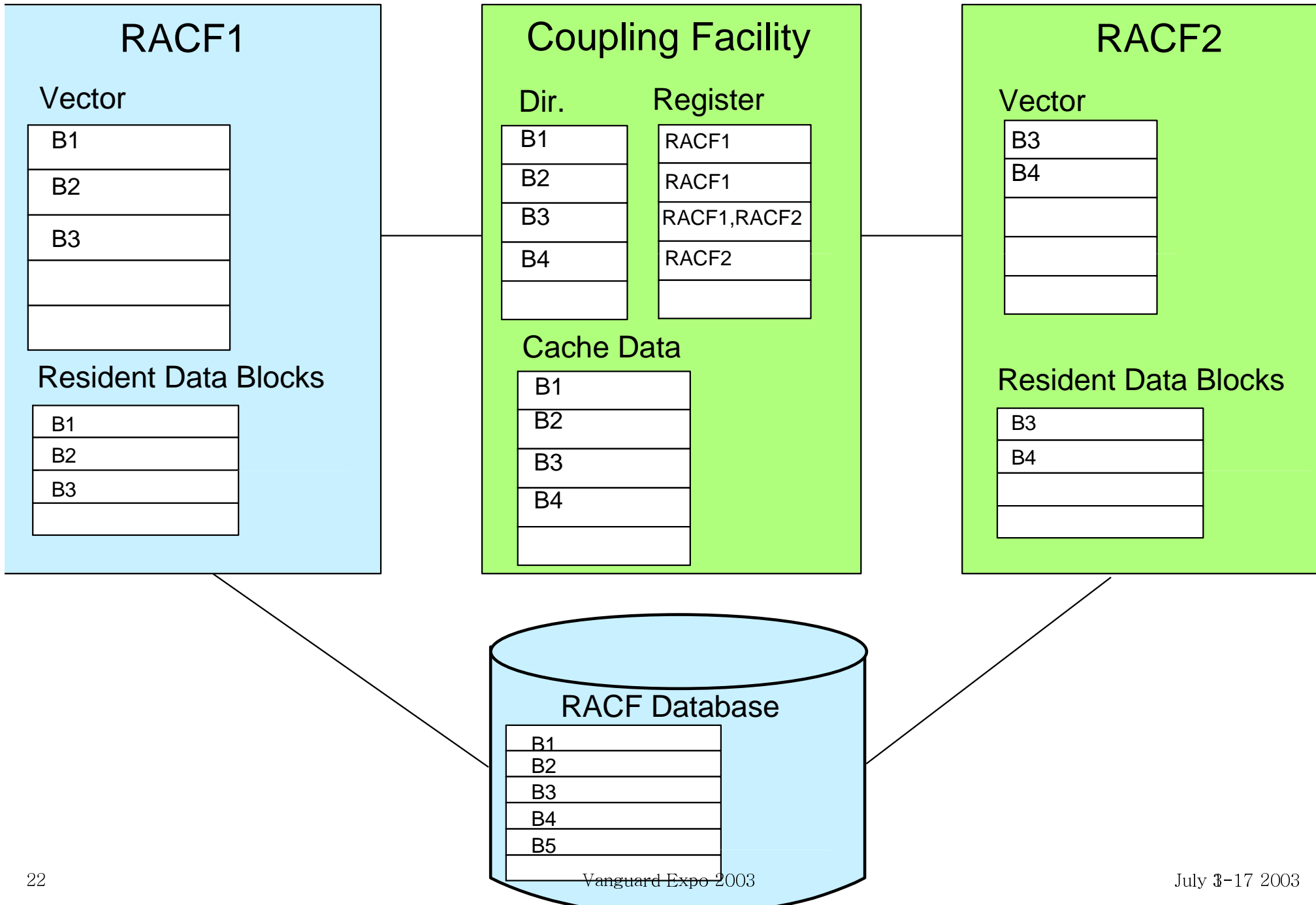

Size of Coupling Facility Cache

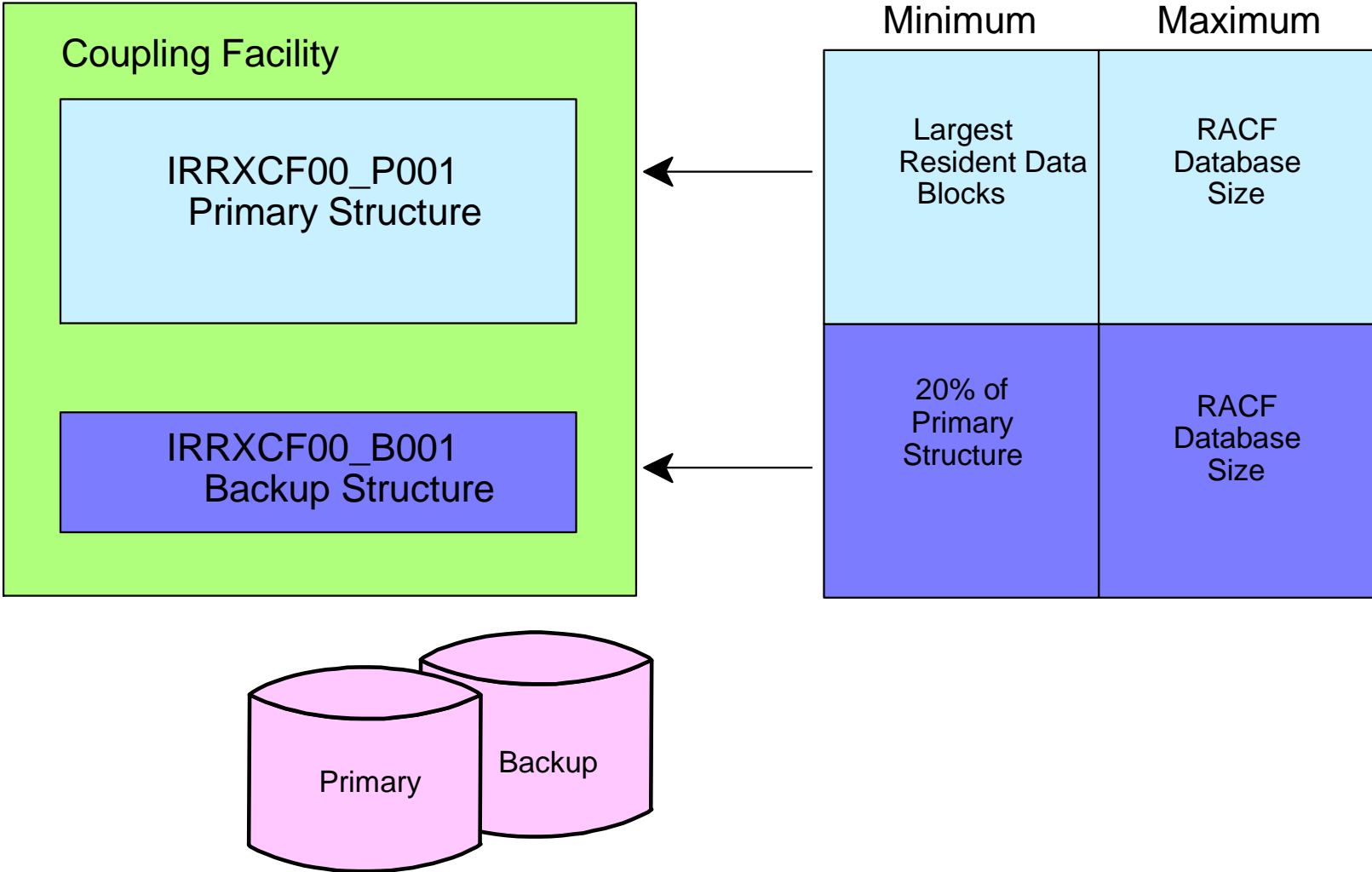

Operational States and Modes

		States	
		Active	Inactive
Modes	Data Sharing	Yes	Yes
	Read-Only	Yes	Yes
	Non-Data Sharing	Yes	Yes

Data Sharing Mode

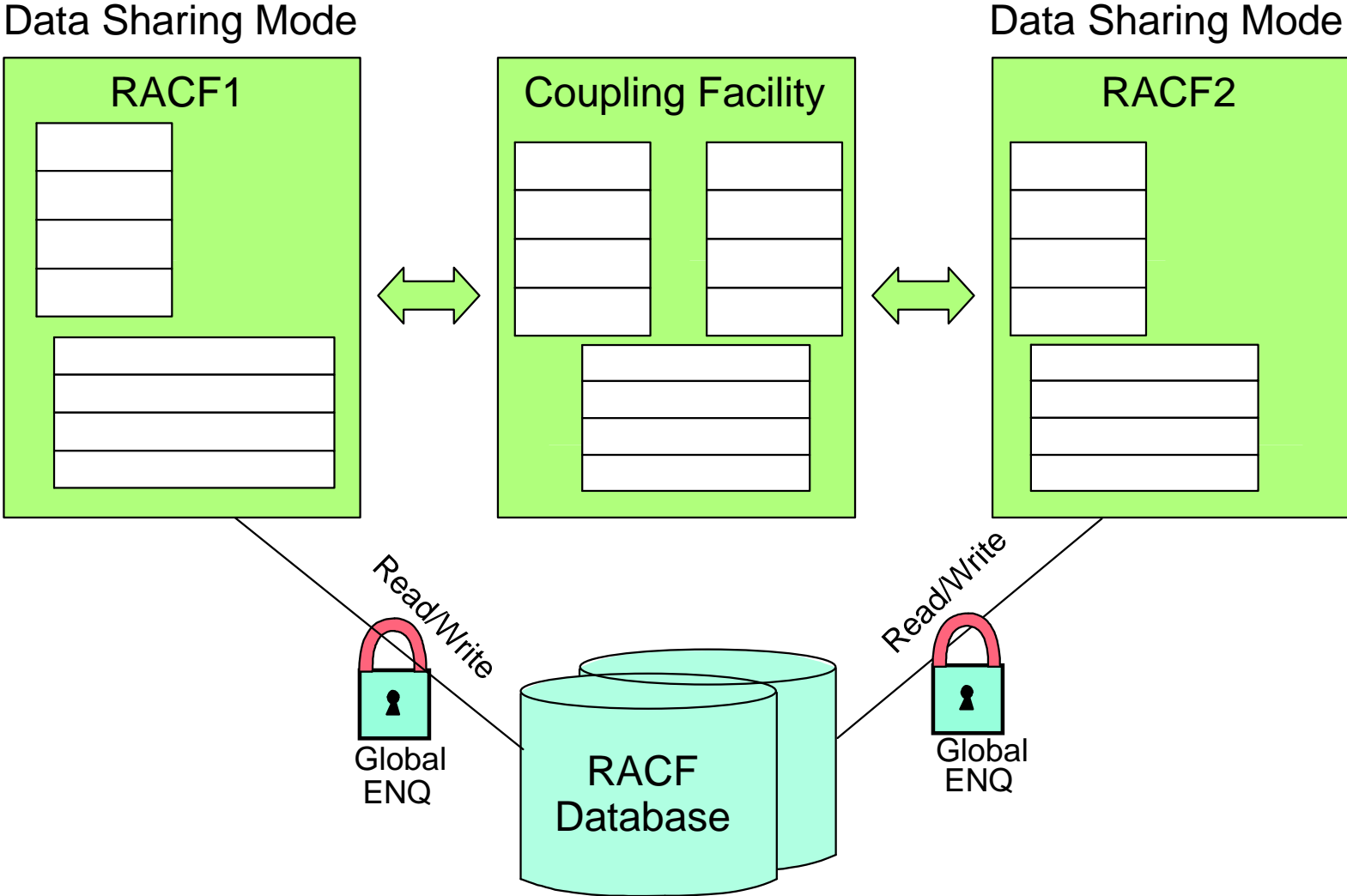

Data Sharing and Read-Only Modes

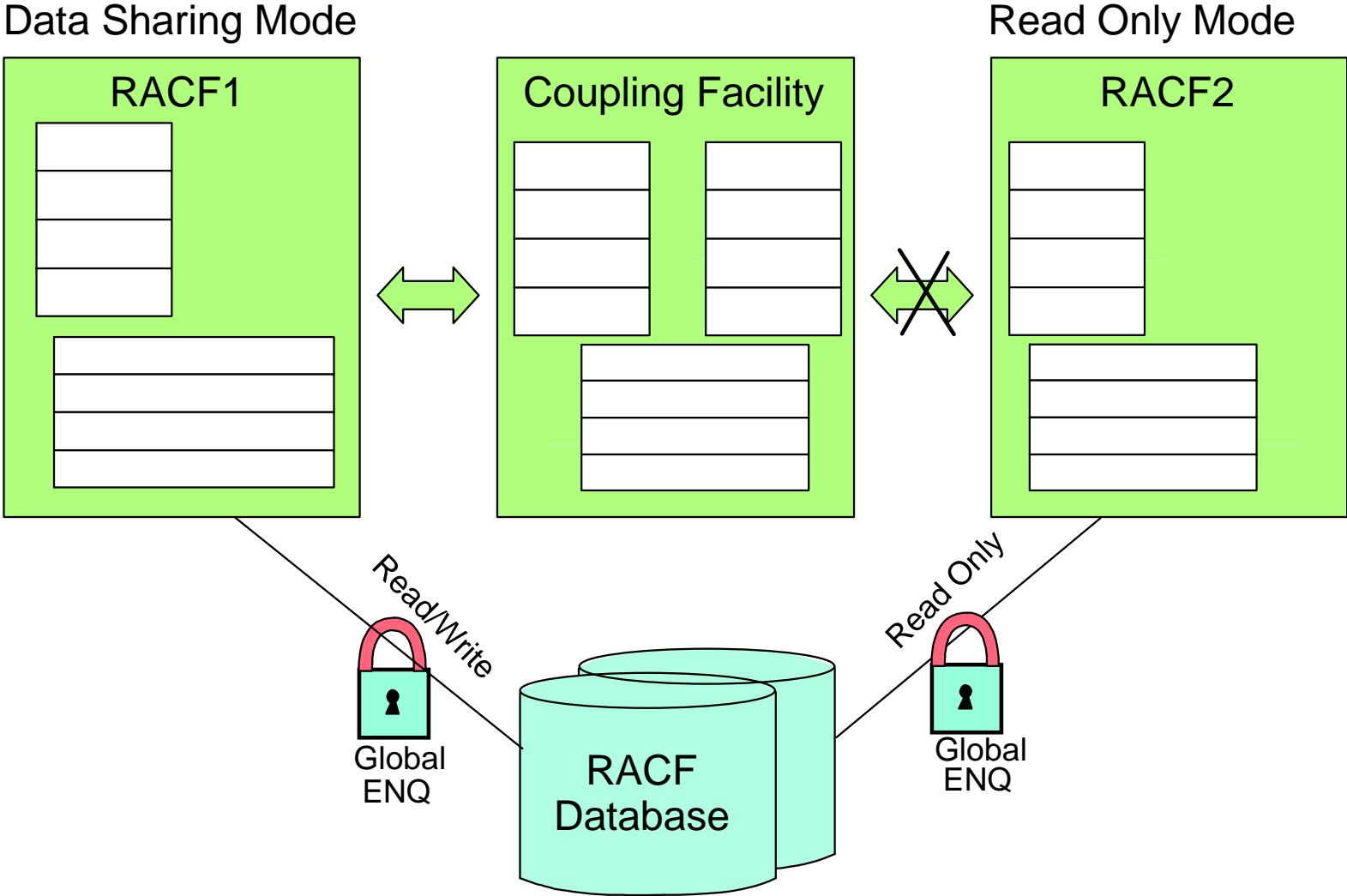

Non-Data Sharing Modes

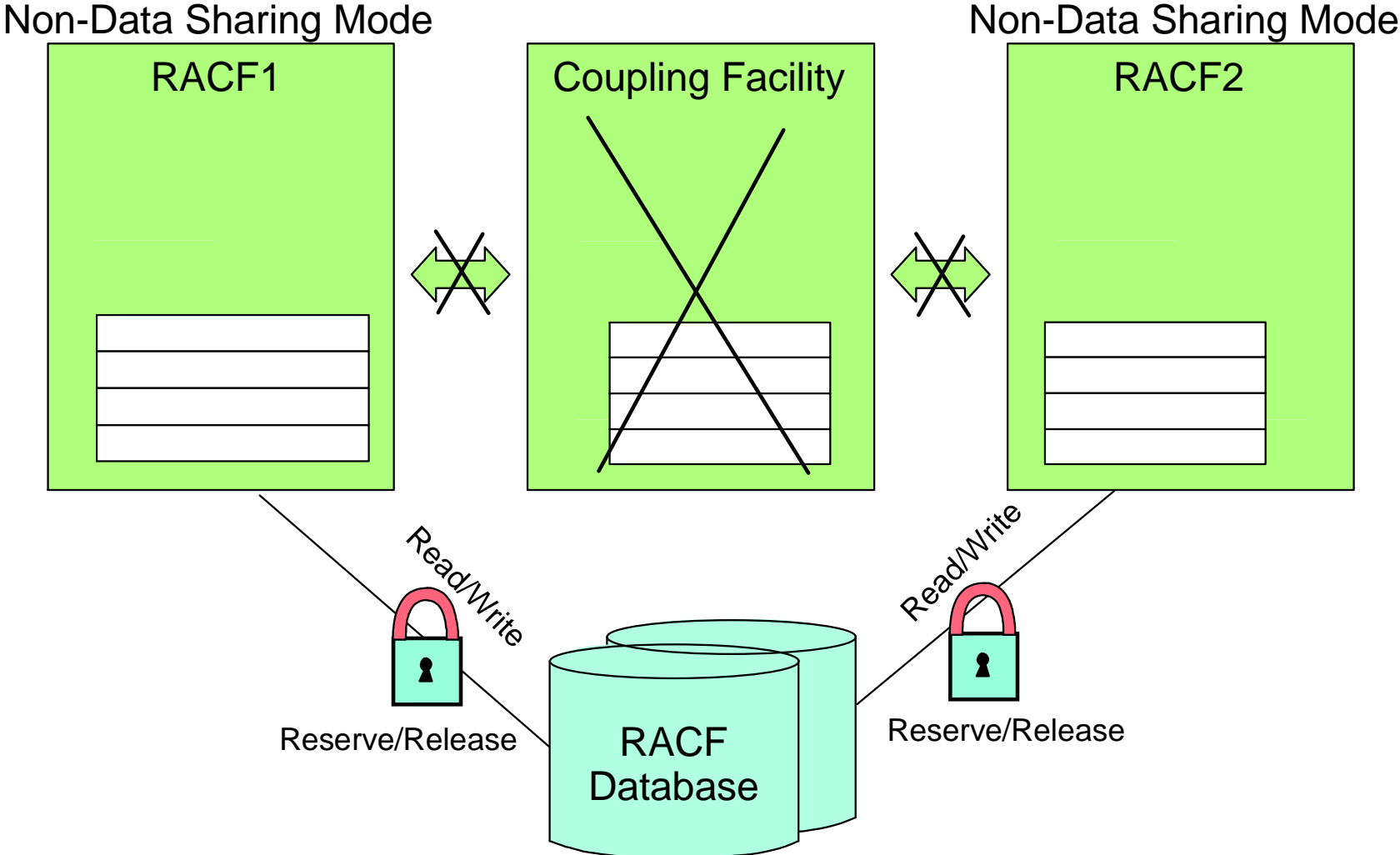

How Do Modes Change?

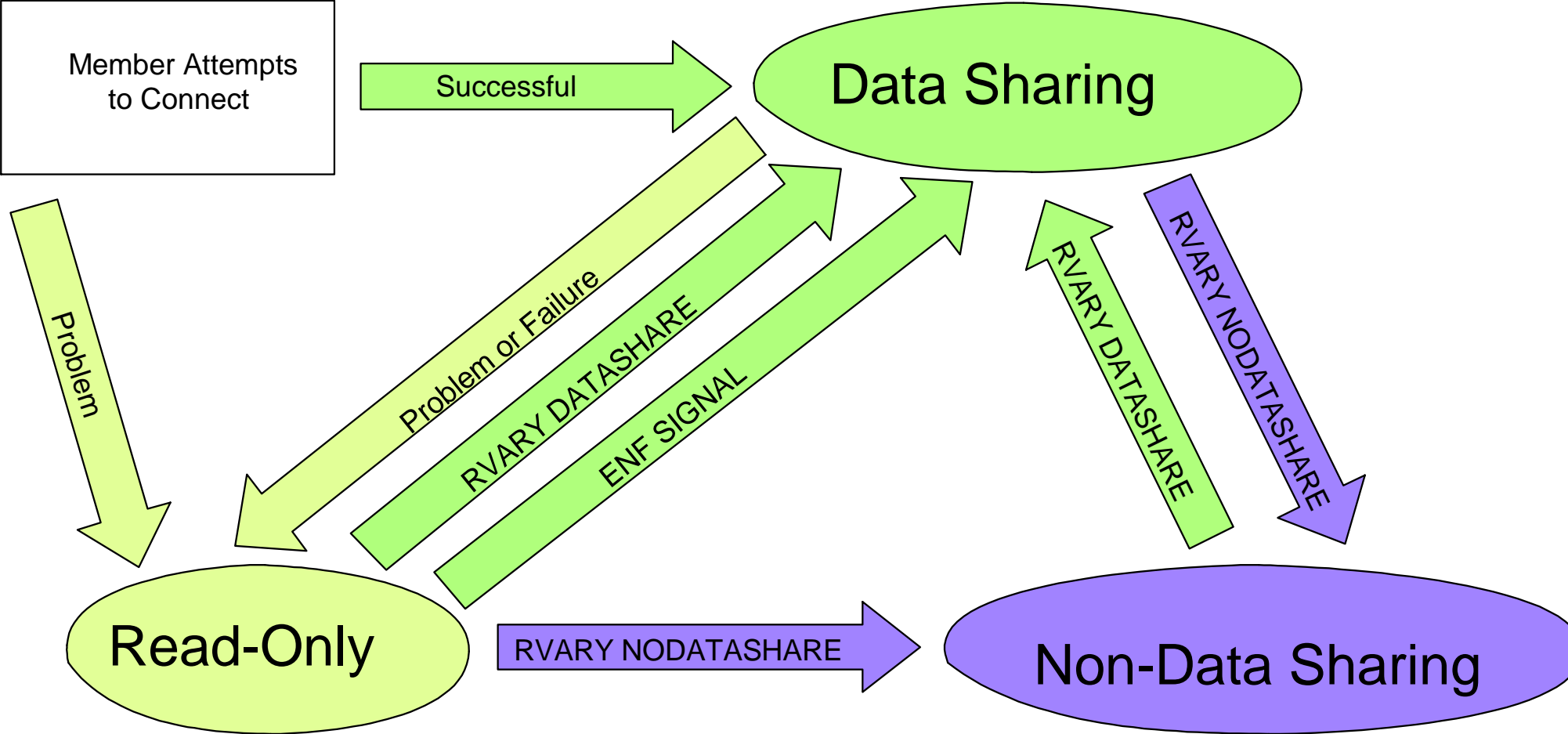

The CFRM Couple Data Set

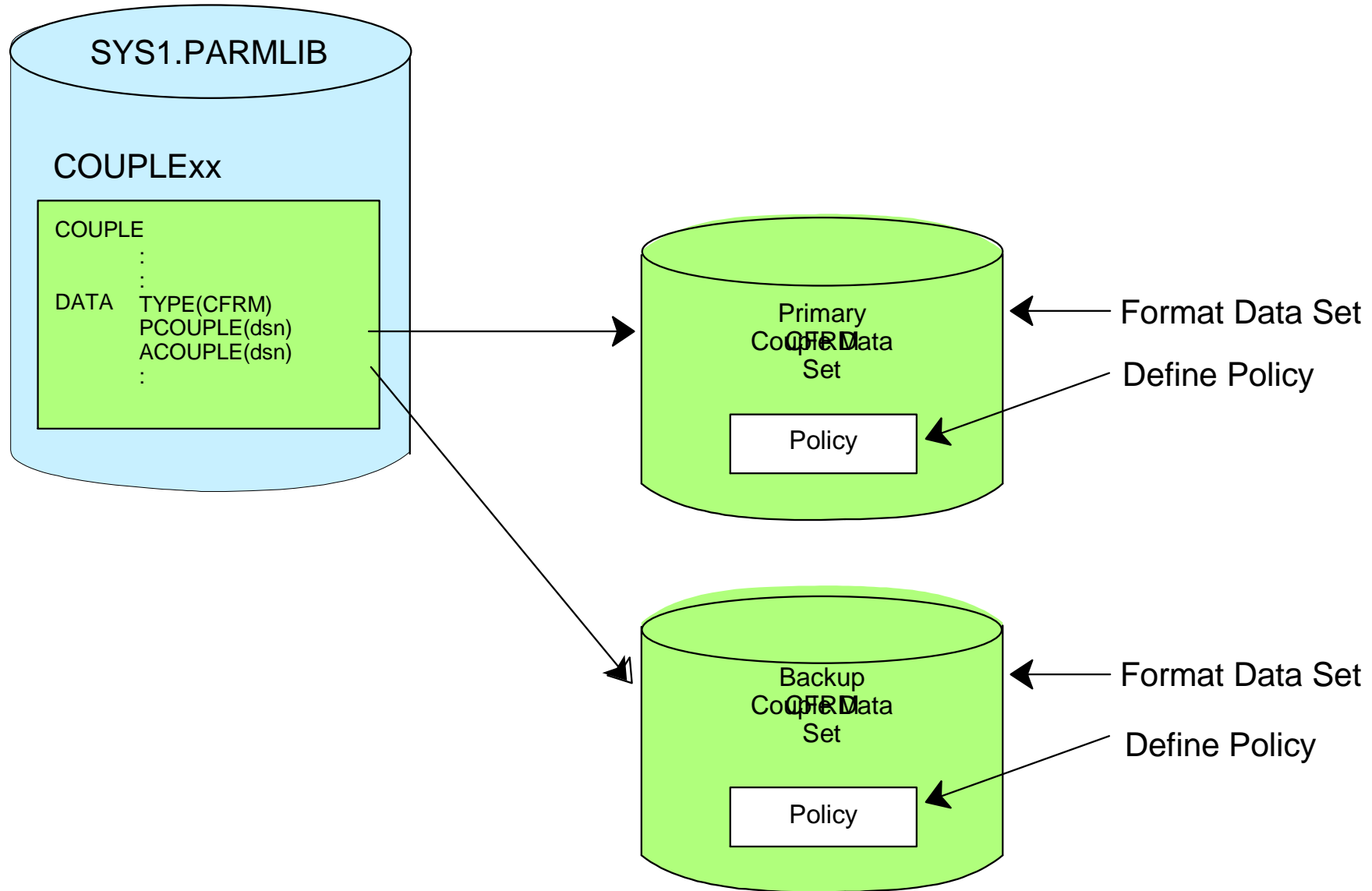

Formatting The CFRM Couple Data Set

```
// FORMAT          JOB          MSGCLASS=H, NOTIFY=JJONES, MSGLEVEL=(1,1)
// STEP            EXEC          PGM=IXCL1DSU
// STEPLIB         DD            DSN=SYS1.MIGLIB, DISP=SHR
// SYSPRINT        DD            SYSOUT= *
// SYSIN           DD *
//
//
```

```
DEFINEDS          SYSPLEX( PLEX1 )
                  DSN(CFRM_couple_dsn) VOLSER(vvvvvv)
                  CATALOG
```

```
DATA TYPE(CFRM)
```

```
ITEM  NAME(POLICY)  NUMBER(3)
ITEM  NAME(CF)      NUMBER(2)
ITEM  NAME(STR)     NUMBER(6)
ITEM  NAME(CONNECT) NUMBER(6)
```

```
/*
```

Coupling Facility Storage Calculation

Suggested Minimum Starting Point:

Primary Structure Size = $(RDB \times 4K) + (.1 \times RDB \times N \times 4K)$

Backup Structure Size = $(.2 \times \text{Primary Structure Size})$

Where: RDB = Largest Number of Resident Data Blocks
N = Number of Systems in Sysplex

Example For 16-Way Sysplex

Primary Structure Size = $(255 \times 4K) + (26 \times 16 \times 4K)$
= 2684K

Backup Structure Size = $(.2 \times \text{Primary Structure Size})$
= 537K

Defining The CFRM Couple Data Set

```
//DEFPOL      JOB          MSGCLASS=H=JJONES ,MSGLEVEL(1,1)
//           EXEC          PGM=IXCMIAPU
//SYSPRINT    DD          SYSOUT=*
//SYSIN       DD          *
DATA  TYPE(CFRM) REPORT(YES)
DEFINE POLICY NAME(POL1) REPLACE(YES)
  CF  NAME(FACIL01)      TYPE(009674))      MFG(IBM)      PLANT(PK)
                                SEQUENCE(0000040021)      PARTITION(1)
                                CPCID(00)      SIDE(1)      DUMPSPACE(2000)
  CF  NAME(FACIL02)      TYPE(009674))      MFG(IBM)      PLANT(PK)
                                SEQUENCE(0000040022)      PARTITION(1)
                                CPCID(00)      SIDE(1)      DUMPSPACE(2000)
STRUCTURE NAME(IRRXCF00_P001)
          SIZE(2688)  PREFLIST(FACIL01,FACIL02)
STRUCTURE NAME(IRRXCF00_B001)
          SIZE(538)  PREFLIST(FACIL01,FACIL02)
/*
```

Unit Summary

- The Sysplex Environment
- RACF Sysplex Communication
- RACF Sysplex Data Sharing
- Recovery Modes
- Defining the Coupling Facility Policy for RACF