

MERVA ESA Components



# MERVA Message Processing Client for Windows NT User's Guide

*Version 4 Release 1*



MERVA ESA Components



# MERVA Message Processing Client for Windows NT User's Guide

*Version 4 Release 1*

**Note!**

Before using this information and the product it supports, be sure to read the general information under “Appendix C. Notices” on page 161.

**Second Edition, December 1999**

This edition applies to

Version 4 Release 1 of IBM MERVA ESA Components (5648-B30)

and to all subsequent releases and modifications until otherwise indicated in new editions.

© **Copyright International Business Machines Corporation 1997, 1999. All rights reserved.**

US Government Users Restricted Rights – Use, duplication or disclosure restricted by GSA ADP Schedule Contract with IBM Corp.

---

# Contents

|   |            |
|---|------------|
| <b>About This Book</b> . . . . .              | <b>vii</b> |
| Purpose . . . . .                             | vii        |
| Audience . . . . .                            | vii        |
| How This Book Is Organized . . . . .          | vii        |
| Conventions and Terminology Used in This Book | viii       |

---

## Part 1. General Introduction to the MERVA Message Processing Client . 1

### Chapter 1. Introducing the MERVA Message Processing Client . . . . . 3

|  |   |
|--|---|
| Overview . . . . .                                 | 3 |
| Concept of Messages . . . . .                      | 4 |
| Message Groups . . . . .                           | 4 |
| Message Parts . . . . .                            | 5 |
| Connection to Networks and Other Systems . . . . . | 6 |

### Chapter 2. Getting Started . . . . . 7

|  |    |
|--|----|
| Starting the MERVA Message Processing Client . . . . . | 7  |
| Starting As a Remote Client . . . . .                  | 7  |
| Starting On the Same Workstation . . . . .             | 8  |
| Startup Options . . . . .                              | 8  |
| Changing Your Password . . . . .                       | 9  |
| Synchronizing Your Password . . . . .                  | 9  |
| Changing Settings . . . . .                            | 10 |
| Changing Colors . . . . .                              | 14 |
| How to Get Help . . . . .                              | 14 |
| Using Accelerator Keys . . . . .                       | 14 |
| Stopping the MERVA Message Processing Client . . . . . | 15 |

### Chapter 3. Example of Message Handling and Routing . . . . . 17

|  |    |
|--|----|
| A Graphic View of Message Processing . . . . .   | 17 |
| A Step-By-Step Description of Message Processing | 18 |

---

## Part 2. Using the Message-Processing Functions . . 19

### Chapter 4. The Function List Window 21

|   |    |
|---|----|
| Understanding the Function List Window Layout . . . . . | 21 |
| Working with Menu Items . . . . .                       | 22 |
| User . . . . .  | 22 |
| Selected . . . . .                                      | 22 |
| View . . . . .  | 24 |
| Window . . . . .  | 24 |
| Help . . . . .  | 24 |
| Defining the Selection for the Functions . . . . .      | 25 |
| The Function List . . . . .                             | 25 |
| Working with Action and Window Buttons . . . . .        | 26 |

### Chapter 5. The Message List Window 27

|  |    |
|--|----|
| Understanding the Message List Window Layout . . . . . | 27 |
|--|----|

|   |    |
|---|----|
| Working with Menu Items . . . . .                     | 28 |
| Selected . . . . .                                    | 28 |
| View . . . . .  | 29 |
| Window . . . . .                                      | 29 |
| Help . . . . .  | 29 |
| Defining the Selection for the Message List . . . . . | 29 |
| The Message List . . . . .                            | 30 |
| Working with Action and Window Buttons . . . . .      | 30 |

### Chapter 6. Working with Message-Processing Windows . . . . . 33

|  |    |
|--|----|
| General Description . . . . .                  | 33 |
| Understanding the Structure of a Message Part  | 33 |
| Navigation Elements . . . . .                  | 33 |
| Entering Data in S.W.I.F.T. Messages . . . . . | 34 |
| Authentication Checking . . . . .              | 35 |
| Working with the Prompt Codewords Window       | 35 |
| Working with the Prompt Correspondent Window   | 36 |
| Working with the Clipboard . . . . .           | 36 |
| Displaying only Fields with Data . . . . .     | 37 |
| Checking Errors . . . . .                      | 37 |
| Understanding the Text View of a Message Body  | 38 |
| Finding Text in the Text View . . . . .        | 40 |
| Message Parts . . . . .                        | 41 |
| MERVA-Related Data . . . . .                   | 42 |
| Telex Envelope . . . . .                       | 45 |
| MERVA Link Envelope . . . . .                  | 45 |
| Envelopes View . . . . .                       | 46 |
| Actions for Message Processing . . . . .       | 48 |

### Chapter 7. Creating Messages. . . . . 53

|  |    |
|--|----|
| Creating a New Message . . . . .                     | 53 |
| Working with the Create Message Window . . . . .     | 55 |
| Working with Menu Items . . . . .                    | 57 |
| Working with Action and Window Buttons . . . . .     | 58 |
| Creating a Message by Using a Template . . . . .     | 59 |
| Creating a S.W.I.F.T. Message for Telex Transmission | 60 |
| Fields Filled Automatically . . . . .                | 61 |
| Telex Header Fields . . . . .                        | 62 |
| Telex Testkey Fields . . . . .                       | 63 |

### Chapter 8. Retyping Messages . . . . . 65

|  |    |
|--|----|
| Selecting a Message for Verification . . . . .   | 65 |
| Verifying a Message . . . . .                    | 65 |
| Working with Menu Items . . . . .                | 67 |
| Working with Action and Window Buttons . . . . . | 68 |
| Verifying a Telex Message . . . . .              | 68 |

### Chapter 9. Authorizing Messages . . . . . 69

|  |    |
|--|----|
| Selecting a Message for Authorization . . . . .  | 69 |
| Authorizing a Message . . . . .                  | 69 |
| Working with Menu Items . . . . .                | 71 |
| Working with Action and Window Buttons . . . . . | 72 |

Authorizing a Telex Message . . . . . 72

**Chapter 10. Editing Messages. . . . . 73**

Selecting a Message for Editing . . . . . 73  
Editing a Message . . . . . 73  
    Working with Menu Items . . . . . 75  
    Working with Action and Window Buttons . . . 76  
Editing a Telex Message . . . . . 77

**Chapter 11. Displaying Messages . . . . . 79**

Selecting a Message for Displaying . . . . . 79  
Displaying a Message . . . . . 79  
    Working with Menu Items . . . . . 80  
    Working with Window Buttons . . . . . 82

**Chapter 12. Printing Messages . . . . . 83**

Selecting a Message for Printing . . . . . 83  
Printing a Message by Using Copy to Print. . . . 83  
Printing a Working Copy of a Message . . . . . 84

**Chapter 13. Processing Telex and Free Format Messages . . . . . 85**

Creating Telexes . . . . . 85  
Creating a Telex Envelope . . . . . 86  
    Creating the Telex Header . . . . . 87  
    Creating the Testkey Fields . . . . . 87  
Working with the Dispatch Function . . . . . 87  
    Calculating Testkeys . . . . . 88  
    Routing Negatively Acknowledged Telex Messages . . . . . 89  
    Verifying Testkeys . . . . . 91  
    Routing Messages to the Telex Network . . . . 92  
Viewing Telex Information in Telex Envelopes . . 93  
    Viewing Telex Header Information . . . . . 93  
    Viewing Telex Testkey Information . . . . . 94  
    Viewing General Telex Information . . . . . 95  
Creating a Free Format Message . . . . . 96

**Chapter 14. Maintaining Templates. . . . . 97**

Selecting a Template . . . . . 97  
Displaying a Template. . . . . 99  
    Working with Menu Items . . . . . 100  
    Working with Window Buttons . . . . . 101  
Editing a Template . . . . . 101  
    Working with Menu Items . . . . . 102  
    Working with Window Buttons . . . . . 104  
Deleting Templates . . . . . 104

---

**Part 3. Appendixes . . . . . 107**

**Appendix A. Installation and Customization . . . . . 109**

Installing the MERV A Message Processing Client 109  
    System Requirements. . . . . 109  
    General Description . . . . . 110  
    Installation Steps . . . . . 111  
    Installation Verification . . . . . 111  
    Corrective Service . . . . . 111

Customizing Message Processing for the MFCL Client . . . . . 112

Customizing Communication Systems for the MERV A Message Processing Client . . . . . 112

    SNA Customization for an MFCL Client on Windows NT . . . . . 113  
    TCP/IP Customization for an MFCL Client on Windows NT . . . . . 114  
    SNA Customization for an MFCL Server on Windows NT . . . . . 114  
    TCP/IP Customization for an MFCL Server on Windows NT . . . . . 115  
    SNA Customization for an MFCL Server on ESA 116  
    TCP/IP Customization for an MFCL Server on ESA . . . . . 116

Customizing the Data Transfer Service (DTS) of the MERV A Message Processing Client . . . . . 116

    Introduction to Node Resource Groups . . . . 116  
    Example A — Message Processing . . . . . 118  
    Example B — MFCL Server with a Local and a Remote Client . . . . . 119  
    Example C — MFCL Server with a Local and Two Remote Clients . . . . . 123  
    General DTS Profile Structure of an MFCL Client . . . . . 127  
    General DTS Profile Structure of an MFCL Server . . . . . 129  
    General DTS Profile Structure of MFCL Client/MFCL Server . . . . . 130  
    DTS Profile Contents (MFCL Client) . . . . . 131  
    DTS Profile Contents (MFCL Server) . . . . . 135  
    DTS Profile Implementation . . . . . 137  
    A MERV A Family Client DTS Sample Configuration . . . . . 138

**Appendix B. Diagnosing Problems 143**

The MERV A Message Processing Client Log Files 143  
The Client Diagnosis Log . . . . . 144  
    Exception Messages . . . . . 146  
    Trace Messages . . . . . 147  
Communication Diagnosis Log . . . . . 149  
    Example of a Log File without Errors . . . . 149  
    Example of a Log File with Errors . . . . . 152  
Logging Relationships . . . . . 153  
    Logging within the Components of the MERV A Message Processing Client . . . . . 153  
    MERV A Server Logs . . . . . 153  
    Setting the Amount of Logging Data . . . . . 153  
Problem Determination . . . . . 154  
    Initial Evaluation of a MERV A Message Processing Client Problem . . . . . 154

**Appendix C. Notices . . . . . 161**

Trademarks . . . . . 162

**Glossary . . . . . 165**

**Bibliography. . . . . 169**

IBM MERV A Publications . . . . . 169  
    MERV A ESA Components Books . . . . . 169

MERVA ESA Books . . . . . 169  
S.W.I.F.T. Publications . . . . . 169

**Index . . . . . 171**





---

## About This Book

This chapter describes who should read this book, why you should read this book, and how this book is organized.

---

### Purpose

Read this book to find out how to use the IBM MERVA Message Processing Client. You learn how to start and work with the message-processing functions, such as creating, displaying, editing, retyping, authorizing, and printing messages.

---

### Audience

This book is written for users of the MERVA Message Processing Client. It is intended for message-processing personnel who works with messages.

It is assumed that you are familiar with S.W.I.F.T. messages and S.W.I.F.T. terminology as defined in the *S.W.I.F.T. User Handbook*, published by the Society for Worldwide Interbank Financial Telecommunication s.c., (S.W.I.F.T.), La Hulpe, Belgium. And it is assumed that you are familiar with telex terminology as defined in the documentation provided by your local telecommunications authority.

---

### How This Book Is Organized

The first part of this book provides general information on the MERVA Message Processing Client by giving an overview of the product and by describing what to do when you use it for the first time. The second part describes the message-processing functions in detail. The third part contains appendixes that describe installation and configuration, and diagnosing problems.

This book also contains a glossary, a bibliography, and an index.

Note that this book describes all available functions of the MERVA Message Processing Client. Unless otherwise indicated, the functions apply to the following MERVA features:

- MERVA USE & Branch for Windows NT
- MERVA USE & Branch for Windows NT with SWIFT Link
- MERVA ESA

You might, however, not be allowed to access all these functions. The functions you are allowed to carry out are determined by the authorization for your user ID. They are also determined by the customization of the MERVA server system that establishes the message flow.

Possible settings for your user ID on the server are:

- Functions and commands you are allowed to use
- Types of messages you are allowed to process
- External networks you are allowed to exchange messages with

The illustrated examples and reference material in this book describe the system as supplied to you. The system, however, can be customized in many ways to suit

your working methods. Therefore, it is possible that the windows that are shown in this book are different from the windows that are displayed to you on your screen as you work.

---

## **Conventions and Terminology Used in This Book**

In this book, the following naming conventions apply:

- MERVA Workstation is used when the description applies to MERVA USE & Branch for Windows NT and MERVA USE & Branch for Windows NT with SWIFT Link.
- MERVA ESA is used when the description applies only to MERVA ESA.
- MERVA is used when the description applies to all MERVA features.

---

## **Part 1. General Introduction to the MERVA Message Processing Client**

This part of the book gives you an overview of the components and functions of the MERVA Message Processing Client. It also tells you how to start the MERVA Message Processing Client and shows you an example of how to handle a message.



---

# Chapter 1. Introducing the MERVA Message Processing Client

The MERVA Message Processing Client is part of the MERVA family of products for financial institutions. You can use these products for message handling on various platforms.

The MERVA Message Processing Client has a common graphic user interface for message-processing functions for all MERVA server systems. The modern graphic interface displays messages in a user-friendly way. When you use this interface, you can carry out different tasks for different kinds of messages.

The MERVA Message Processing Client provides the same level of security as the message-processing functions on the server systems.

A state-of-the-art graphical user interface makes it easy for you to handle the messages that you work with. For example, you can use clipboard functions, or you can view different messages at the same time.

---

## Overview

Message-processing is performed in several steps. With the MERVA Message Processing Client you can carry out the following message-processing tasks:

- Create messages  
Create all messages that are defined in your system. You can create, for example, a S.W.I.F.T. message of any message type belonging to message categories 1 to 9 as defined in the *S.W.I.F.T. User Handbook*.  
You can also use previously defined templates as outlines for the creation of recurring messages.
- Verify messages  
Verify messages by retyping specific data to match the data that is originally entered.
- Authorize messages  
Authorize messages in one or more authorization steps before they are sent to the S.W.I.F.T. or telex network.
- Edit messages  
Change an incomplete message, or a previously created message that failed verification, authorization, or that is rejected by the respective network.
- Display, print, and delete messages  
Retrieve one or more messages to display, print, or delete them.
- Search for messages  
Retrieve one or more messages that are based on specific search values.
- Create and maintain templates  
Save messages as templates for later retrieval, update, or processing.
- Send message as telex  
Send a message in the form of a telex.

## Concept of Messages

To handle different message types, the MERVA Message Processing Client has a concept of messages that divides messages into different groups that are hierarchically ordered:

- Message applications
- Message categories
- Message types

Messages also have different message parts. The message groups and message parts are described in the following sections.

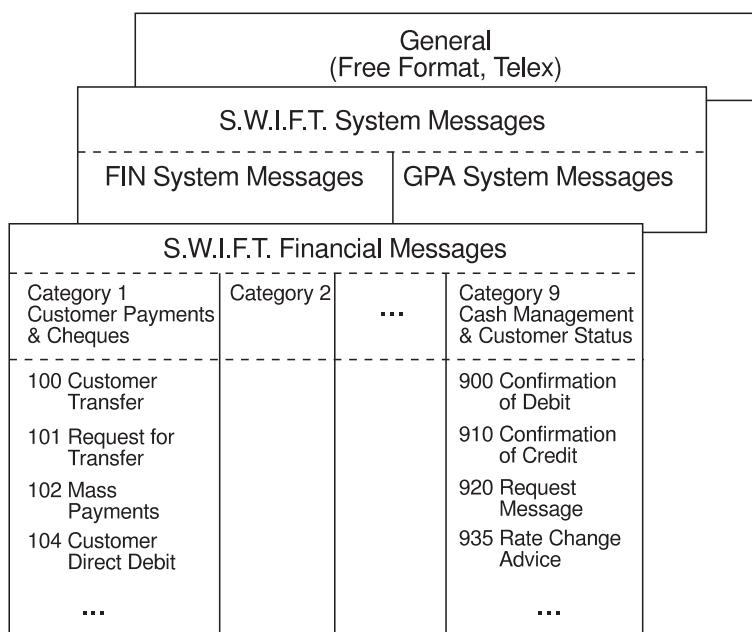

Figure 1. The Concept of Messages

## Message Groups

### Message Applications

Message applications specify an application area to which the message categories and messages belong.

MERVA uses the following applications:

- S.W.I.F.T. Financial Messages
- S.W.I.F.T. System Messages
- General, such as free format or telex

An application contains one or more message categories.

### Message Categories

Message categories contain a group of messages that are logically related within an application, for example:

- The application S.W.I.F.T. Financial Messages consists of nine categories, from category 1, Customer Payments & Cheques, to category 9, Cash Management & Customer Status.

- S.W.I.F.T. System Messages contain the categories FIN System Messages and GPA System Messages.

When you create messages, your rights to message categories depend on settings in your user profile.

## Message Types

Each category consists of different message types, for example, S.W.I.F.T. Financial Messages category 1 consists of Customer Transfer (type 100), Request for Transfer (type 101), Mass Payments (type 102), Customer Direct Debit (type 104), and others.

Which message types you can create depends on the settings in your user profile.

## Message Parts

A message consists of the following parts:

- Message body
- MERVA-related data
- Message envelopes

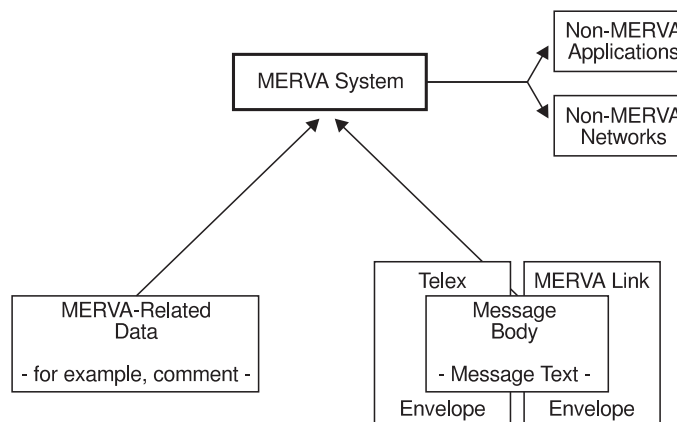

Figure 2. The Different Message Parts

## Message Body

The message body contains the message text. This text contains the data that is sent to other MERVA systems, non-MERVA applications, and networks.

The following formats of the message body are valid:

- S.W.I.F.T.
  - The S.W.I.F.T. message is formatted according to the S.W.I.F.T. rules as defined in the *S.W.I.F.T. User Handbook*.
- Telex
  - The data in the telex message is limited to telex definitions.
- Free format message

## MERVA-Related Data

MERVA-related data represents data that MERVA uses while processing the message, such as comments. This data is not included in the message body and is only used by MERVA.

The MERVA-Related Data window shows you detailed information on this data. The information that is shown depends on the operating system of your MERVA server. You can start the MERVA-Related Data window from any message-processing window that shows the message body.

### Message Envelope

The following message envelopes are valid:

- Telex message envelope  
This message envelope is used to send messages via the telex network.
- MERVA Link envelope  
This message envelope is only valid for messages that are received or are sent via MERVA Link. The data is read-only data.

You can display message envelopes by selecting **Show message envelopes** from the **View** menu of any message-processing window that shows the message body. You then see the Message Envelopes window with detailed information on this data.

---

## Connection to Networks and Other Systems

To send and receive messages, the MERVA system can be connected to the following links:

### S.W.I.F.T. Link

Establishes a link between the MERVA system and the S.W.I.F.T. system to control the transmission of messages between both systems.

### Telex Network

To send messages to the telex network, the MERVA server API of MERVA Workstation establishes a link to a telex program from a vendor of your choice.

### MERVA Link

Allows the exchange of messages with other MERVA systems that have MERVA Link installed.

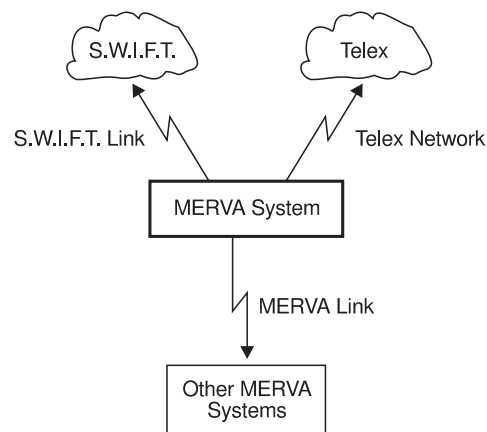

Figure 3. The MERVA System and Its Connection to Networks and Other Systems

For detailed information refer to *MERVA ESA V4 Concepts and Components*.



---

## Chapter 2. Getting Started

This chapter tells you how to start the MERV Message Processing Client. It also describes some features of the MERV Message Processing Client with which you should be familiar before you start using the client.

---

### Starting the MERV Message Processing Client

Before you start the MERV Message Processing Client, check with your system administrator that you have a valid user ID and password for your MERV system.

You can start the MERV Message Processing Client in one of the following ways:

- As a remote client to a MERV Server system
- As message processing integrated in MERV Workstation located on the same workstation

### Starting As a Remote Client

To start the MERV Message Processing Client as a remote client, select **Programs** from the Windows NT **Start** menu, then select **MERV Message Processing Client**. You can also double-click on the MERV Message Processing icon, or select it and press Enter.

To access *Messages and Codes*, double-click on the Messages and Codes icon, or select it and press Enter.

To uninstall the MERV Message Processing Client, double-click on the Uninstall icon, or select it and press Enter.



Figure 4. The MERV Client Icon

You then get the Signon window as shown in the following figure:

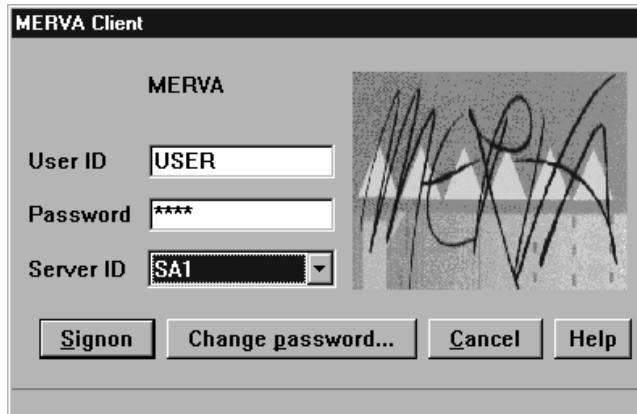

Figure 5. The MERVA Client Signon Window

To sign on to the MERVA Message Processing Client:

1. Enter your user ID and password.
2. Enter a server ID in the **Server ID** field or select a name from the list.  
In the list, you see entries that are customized for your system, such as **SA1** or **Remote**. By default, you see the last used server.
3. Select **Signon**.

According to the customization of your system, you get entry fields in which you enter the conversation security user ID and password.

Select **Cancel** to close the MERVA Client Signon window without signing on.

Select **Help** to get overview information for the current window.

When the signon procedure is successful, you get the Function List window. For a detailed description of the Function List window refer to “Chapter 4. The Function List Window” on page 21.

## Starting On the Same Workstation

To start the MERVA Message Processing Client on the same workstation, select **Messages** from the MERVA Workstation menu, then select **Message Processing**.

You are then directly connected to MERVA Workstation. The rights that are defined for your MERVA Workstation user ID are valid. You do not get the Signon window.

When the signon procedure is successful, you get the Function List window. For a detailed description of the Function List window refer to “Chapter 4. The Function List Window” on page 21.

---

## Startup Options

The MERVA Message Processing Client offers you the following startup options that affect message processing:

### **/TRACE=**

Defines the traces that are to be written to the trace file. Use **/TRACE=ALL** except where stated otherwise.

**Note:** Activate the traces only at the direction of your IBM representative.

**/TRACEFILE=**

Defines the file to which the traces are written. This parameter must contain the full file specification. It must also contain the directory and name of a disk with write access.

**Note:** Activate the traces only at the direction of your IBM representative.

---

## Changing Your Password

To change your password:

1. Select **Change password** in the MERVA Client Signon window.

The following window is shown:



*Figure 6. The Change Password Window*

2. Enter a new password in the **New password** and **Verify password** fields.
3. Select **Accept**.

Select **Cancel** to close the Change Password window without changing the password.

Select **Help** to get overview information for the current window.

Your system administrator can also specify that your password expires after a certain period of time. After this period of time elapses, you are asked to change your password to complete the signon process in the Signon window.

---

## Synchronizing Your Password

The following rule does not apply to MERVA ESA. If your system administrator makes changes to the MERVA system, it might happen that your password stored in the security system, for example in the User Manager of Windows NT, is different from the password stored in MERVA Workstation.

In this case, the Synchronize Passwords window is displayed. It looks like the following:

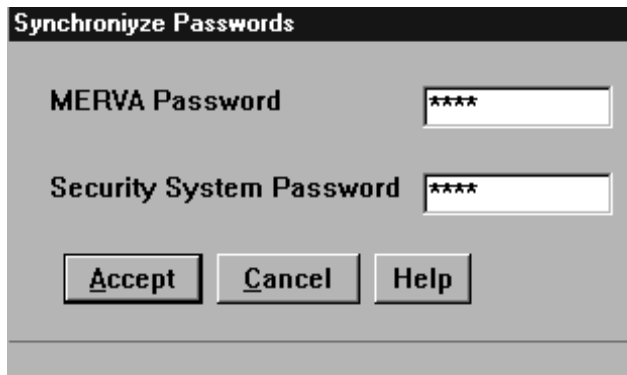

Figure 7. The Synchronize Passwords Window

To synchronize your password:

1. Enter your MERVA password in the **MERVA password** field.
2. Enter your security system password in the **Security system password** field.
3. Select **Accept**.

Both passwords are then synchronized within the databases. You then use the security system password as the actual MERVA password.

Select **Cancel** to close the Synchronize Passwords window without changing the password.

Select **Help** to get overview information for the current window.

---

## Changing Settings

Select **Settings** from the **User** menu of the Function List window to change settings for the window or information that is contained in the window. You then get the MERVA Client Settings window where you can choose the following options:

- **View**

To specify the display of information according to your needs.

- In the **Title components** field, you can specify that the MERVA Server ID and user ID are displayed in the window title.
- In the **Toolbar** field, you can specify whether the toolbar of the message-processing windows contains text or graphics.

- **Print options**

To print to a file or to select a printer and its properties.

- When you select **File**, the output of local message printing is not sent to a printer but stored in a file. Each time you print a message, a dialog asks you to specify the file name and the directory to which the output is to be sent.
- When you select **Printer**, the output of local message printing is sent to a specified printer. To select a printer from the Printers folder, select **Select printer**. The selected printer is then displayed in the field to the right of the **Select printer** push button.

Note that this option is only available if the Printers folder contains a printer object.

To specify printer properties, such as the number of lines per page, select **Properties**. To specify the printer font, select **Font**.

- **Fonts**

To set the fonts for information displayed to you.

- Select **Font for function and message list** to define the font for the contents of function and message lists.
- Select **Font for message type and template list** to define the font for the contents of message type and template lists.
- Select **Font for message-processing windows** to define the font for the message-processing windows.
- Select **Font for status line** to define the font for the status line that explains the state of an object or process.

- **Colors**

To set the foreground and background colors of the prompt and mandatory fields in the message-processing windows.

To change the foreground color of a field:

1. Select the field type from the **Field type** list.
2. Select **Foreground**.
3. Select **Color** or **RGB** to define the color specification mode.
4. According to your color specification mode, select a color from the **Color** list, or from the **RGB values** field.

To change the background color of a field:

1. Select the field type from the **Field type** list.
2. Select **Background**.
3. Select **Color** or **RGB** to define the color specification mode.
4. According to your color specification mode, select a color from the **Color** list, or from the **RGB values** field.

To reset all color settings to the default setting, select **Defaults**.

The field **MERVA** at the bottom of the **Color selection** field is a test field. It gives you a preview of the selected field type in the message-processing windows.

- **Trace**

To set the trace options and the trace file.

Note that you should change these options only at the direction of your IBM representative.

You can select the following types of trace information in the **Trace options** field:

- Select **Client EUI trace** to trace basic operations that refer to the general windows of the MERVA Client.
- Select **MP EUI trace** to trace basic operations that refer to the message-processing windows of the MERVA Client.
- Select **API trace** to trace basic operations that refer to the MERVA Client/Server communication on application layer.
- Select **Data stream trace** to trace basic operations that refer to the MERVA Client/Server communication on transport layer.
- Select **Server trace** to trace basic operations that refer to the MERVA Server request execution on application layer. In case of a remote MERVA Client, this data is written to the trace file of the MERVA Server.

The settings in the **Trace options** field are not saved permanently after you sign off, regardless of whether you select **Save settings** or not.

In the **Trace file** field, you can specify the full path of the trace file. You should store this file on your local workstation. Entries in the **Trace file** field are saved permanently.

With **Trace options** you cannot trace the MERVA Client during the time between start and selection of the MERVA Client settings. Therefore, you can also specify the trace options with the runtime parameters `/trace=all` and `/tracefile=<trace_file_path>`, where *trace\_file\_path* represents your real trace file path. To specify these parameters, change the properties of the MERVA Client object in the MERVA Client folder or the message-processing object in the corresponding MERVA folder. For details refer to “Startup Options” on page 8.

- **Style**

To specify the behavior of the MERVA Client according to your needs.

- Select one of the following options from **Confirmations for message processing**:
  - Select **Confirm successfully completed action** to display a confirmation message for an action that completes the processing of a message successfully, such as **Accept**.
  - Select **Confirm successful intermediate action** to display a confirmation message for an action that does not complete the processing of a message but ends successfully, such as **Save as template**.
- Select one of the following options from **Checking errors dialog for message processing**:
  - Select **Show Checking Errors window for Accept** to display the Checking Errors window after you select **Accept** if the processing of a message is completed with errors. If you deselect this option, you do not get the Checking Errors window but information that errors were found.
  - Select **Show Checking Errors window for Route to telex** to display the Checking Errors window if the processing of a message is completed with errors. If you deselect this option, you do not get the Checking Errors window but information that errors were found.
- Select one of the following options from the **Options** fields on page 2 of the **Customize your individual styles** function:
  - **Fill fields with single option** to specify that an option in a message is automatically added or deleted if the field has only one option. This option is selected by default.
  - **Fill fields with several options** to specify that an option in a message is automatically added or deleted if the field has at least one option.
  - **Do not fill option fields** to specify that an option in a message is never changed automatically.
- Select one of the following options from the **Repeatable sequences** fields on page 2 of the **Customize your individual styles** function:
  - **Display occurrences stacked** to specify that only a single occurrence of a repeatable sequence is displayed. This option is selected by default.
  - **Display occurrences sequentially** to specify that all occurrences of a repeatable sequence are arranged sequentially.
- Select one of the following options from the **Field tabbing** field on page 2 of the **Customize your individual styles** function:
  - **Manual tabbing with TAB key** to specify that a tab forward is only done if the Tab key is pressed. This option is selected by default.

- **Automatic tabbing after field is filled** to specify that a tab forward is done after the last character of a field is filled, or if the Tab key is pressed.
- Select one of the following options from the **Field checking** field on page 2 of the **Customize your individual styles** function:
  - **Always when a field is left** to specify that the contents of a field are permanently checked. This option is selected by default.
  - **When a filled field is left** to specify that a field is only checked if it contains data.
  - **No field checking** to specify that a field is not checked permanently. This setting does not affect the checking of the complete message.
- In the **Message field display** field on page 3 of the **Customize your individual styles** function, you can specify the initial display of a message depending on the different message-processing functions. Select one of the following options:
  - **Display only fields with data** to display only fields that contain data. If you do not select this option, all message fields are shown regardless of whether they contain data.
  - **Display sequences collapsed** to specify that the lower-level data of a message is not shown at the same time.

- **Keys**

In the field **Key assignments for message-processing actions**, you can specify your own shortcuts for specific actions of message handling.

To specify a shortcut of this kind:

1. Select a message-processing action from the **Action** list box.
2. Select an alphabetic key from the **Assigned key combination** list box.
3. Select one or more of the check boxes **Shift**, **Ctrl**, and **Alt**.

To reset the key assignment to the default values, select **Defaults**.

In the field **Key assignments for message-processing strings**, you can specify your own shortcuts for predefined text. With these shortcuts, you can insert text in message fields while you process a message.

To specify a shortcut of this kind:

1. Specify the key assignment for the string in the entry field of the **Description** list box to identify it.
2. Select an alphabetic key from the **Assigned key combination** list box.
3. Select one or more of the check boxes **Shift**, **Ctrl**, and **Alt**.
4. In the field **String that is inserted**, enter the text that belongs to the shortcut.
5. Select **Add** to add the defined string key assignment to your individual assignments.

If the defined string key assignment is already used, the **Add** and **Change** buttons are not active.

6. To delete a defined string key assignment, select it. Then select **Remove**.
7. To change a defined string key assignment, select it and change the definition. Then select **Change**.

To save the settings permanently, select **Save settings permanently**. If you then select **OK**, the changes are saved in the profile and reused when you work again with the MERVA Message Processing Client.

---

## Changing Colors

Except for the background color of specific message-processing fields, the colors used are system colors. You can change these background colors in the MERVA Client Settings window. You can change the system colors by using different schemes or by customizing own schemes.

The following system colors are used:

- Window text for input text
- Static text for titles and literals
- Dialog background for the background of read-only fields

---

## How to Get Help

Several types of help are available:

- Press F1 (Help) to get information about the selected item, including the item's purpose and ways to interact with the item.
- Select **Help** from the menu bar of each window to get **Help** menu choices for the active program, such as an index of help topics, general information about the active window, general information about the help facility, a list and description of the keys you can use, and product information.
- The information area displays a brief explanation or description of the state of an object or a process.
- Hover help provides you with brief, descriptive information about the user interface elements, such as toolbar items.

---

## Using Accelerator Keys

The following accelerator keys are defined for the message-processing windows:

|    |                      |
|----|----------------------|
| F2 | Save                 |
| F3 | Close                |
| F4 | Reject               |
| F7 | Route to telex queue |
| F8 | Accept               |

The following accelerator key is defined for the function list view and the message list view:

|    |         |
|----|---------|
| F5 | Refresh |
|----|---------|

To activate the push buttons, enter:

**Alt + 'char'**

'char' is the underlined character of the push button text, for example, **A** stands for the **Accept** push button.

By default, the following accelerator key is defined for prompting:

**Ctrl + P**

To prompt for codewords, currencies, or correspondent information

You can also double-click on the subfield that is enabled for prompting to get the corresponding prompt window.



For information on how to change this key, refer to page 13.

The following accelerator keys are defined for switching between notebook pages in the envelope view of a message:

**Alt + P**

Previous notebook page

**Alt + N**

Next notebook page

---

## Stopping the MERVA Message Processing Client

From the Function List window select **Close** to sign off from the MERVA Message Processing Client. You get a message to confirm the signoff.



---

## Chapter 3. Example of Message Handling and Routing

This chapter describes how to prepare a specific message to send it via the S.W.I.F.T. network.

---

### A Graphic View of Message Processing

A message must pass different processing steps and a series of queues before it can be sent to the network. The sequence in which these steps are completed depends on the customization of your system.

The following graphic shows you an example of the necessary processing steps for a message handling money transfer. Your institution can change the processing steps.

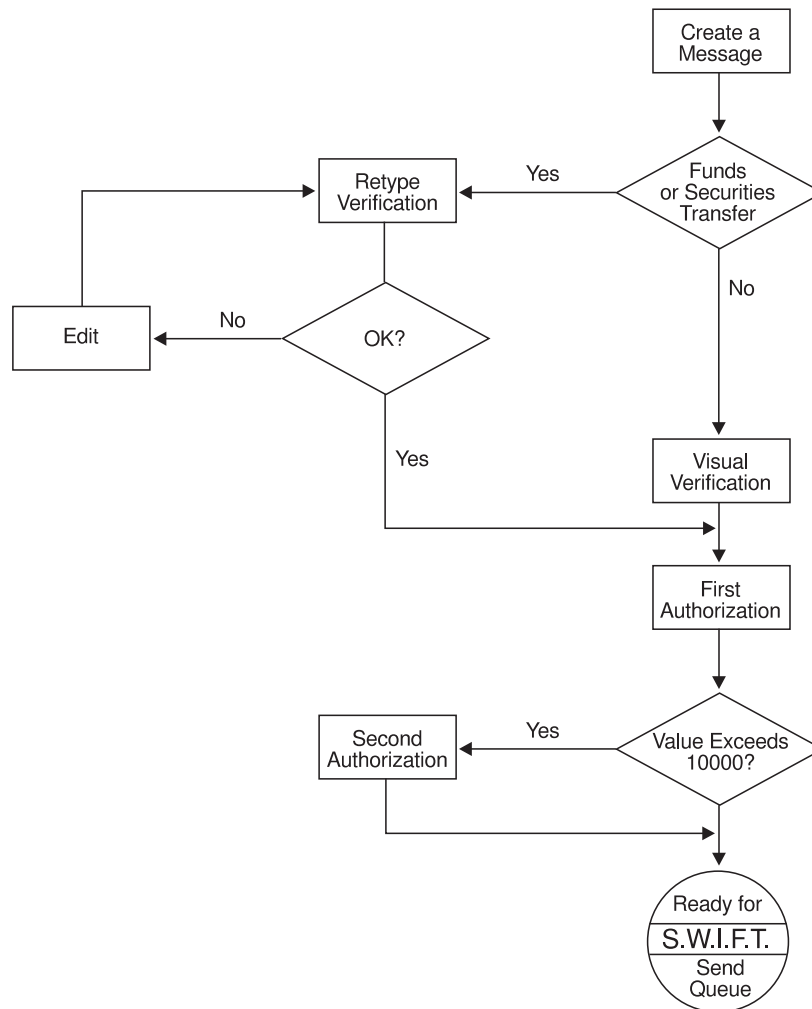

Figure 8. An Example of Message Handling and Routing

For the financial institution that is used as an example in this chapter, the customization specification is as follows:

- **Verify**

- Verify by retyping – Each message that transfers funds or securities must be verified by retyping. This means you must retype specific fields and the MERVA Message Processing Client checks the retyped version against the original version. This eliminates the possibility of a typing error.
- Verify visually – All other messages must be verified visually. This means that you must read through the message to check it for correctness.
- **Authorization one** – Each message must be authorized or approved for sending.
- **Authorization two** – Each message that transfers funds or securities with a value higher than 10000 must be authorized twice.

For security reasons, the financial institution that is used as an example has the following additional rules:

- You cannot verify a message that you create. A different user must do this.
- If two authorization steps are required, different users must perform these steps.
- Only supervisors and people in higher positions are allowed to authorize a message.
- Only the department manager is allowed to authorize a message that transfers funds or securities that exceeds 10000.

---

## A Step-By-Step Description of Message Processing

The message that is shown in the example is handled and routed as follows:

1. A colleague creates a message that transfers funds of 15000. After the message is checked for formal errors, it is routed to the queue of the next message-processing function. The next step is to retype the message to verify it.
2. You are responsible for verifying the message. You select the Retype function to retype all fields that are marked for retyping. You also check the contents by reading through the message.
  - If you do not find any errors, you accept the message. The message is then routed to the queue of the next message-processing function. The next step is to authorize the message.
  - If you find any errors, you reject the message and route it to the next message-processing function. The next step is then to edit the message and route it to the authorization queue.
3. The supervisor must authorize it. After the supervisor checks and accepts the message, it is routed to the next message-processing function. The next step is to authorize the message a second time because the amount exceeds 10000.
4. Because the message transfers funds or securities with an amount that exceeds 10000, the department manager must perform the second authorization. After the department manager checks and accepts the message, it is routed to the S.W.I.F.T. ready-to-send queue.

---

## **Part 2. Using the Message-Processing Functions**

This part of the book explains in detail how you can use the message-processing functions of the MERVA Message Processing Client.



---

## Chapter 4. The Function List Window

The Function List window shows you the functions that contain message lists that are stored in different queues. You can be authorized to use some or all of the functions that are provided by the MERVA Message Processing Client. Your financial institution determines names and usage of the functions.

---

### Understanding the Function List Window Layout

After you sign on to the MERVA Message Processing Client, the Function List window is the first window with which you can work. It looks like the following:

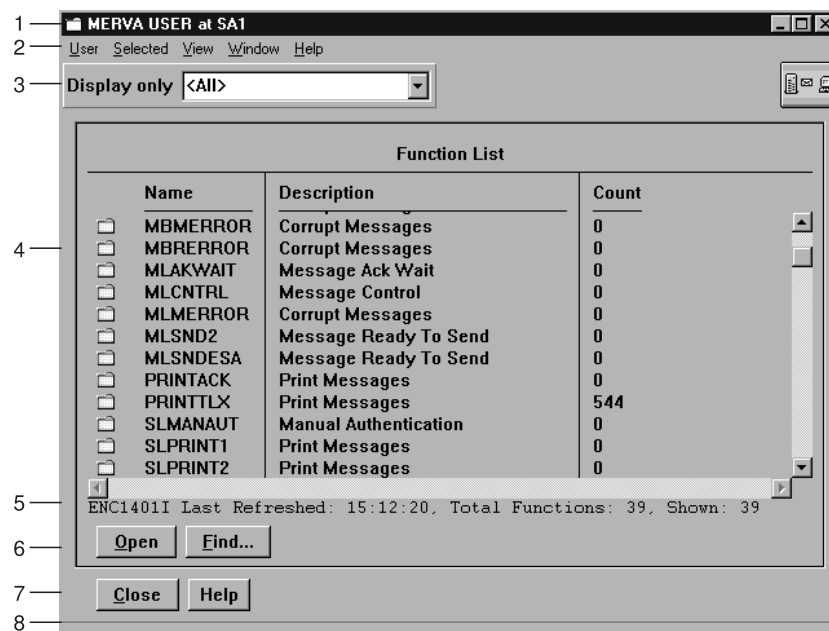

Figure 9. The Function List Window

The Function List window of the MERVA Message Processing Client is divided into several parts:

1. Title bar with window title and activity icon  
The activity icon shows you a server, an envelope, and a terminal. When you issue a request, such as opening a function, the objects in the icon move to indicate that server communication takes place.
2. Menu bar with menu items **User**, **Selected**, **View**, **Window**, and **Help**
3. Selection field **Display only**
4. Function list containing an icon in the form of a folder, name of the function, description of the function contents, and total number of messages contained in the function.
5. Status line
6. Action buttons to perform actions related to the functions
7. Window buttons to perform actions related to the active window
8. Information area

With exception of the title bar, these parts are described in detail in the following sections.

---

## Working with Menu Items

Each menu item has a pull-down menu with different options:

### User

This menu item offers you the following options:

#### **Signoff**

Select **Signoff** to sign off from the MERVA Message Processing Client. You are asked to confirm the signoff.

#### **Settings**

Select **Settings** to change settings for the window or information that is contained in the window. For a detailed description refer to “Changing Settings” on page 10.

#### **Terminate**

Select **Terminate** to stop the MERVA Message Processing Client abnormally. You are asked to confirm the termination.

**Note:** Use this option only if signoff does not work, or if the server returns severe errors.

### Selected

This menu item refers to your selection of functions from the function list. You can select one of the following options:

#### **Open**

To display the contents of the selected message lists.

#### **Find**

To locate messages by specifying find parameters.

If you select **Find**, you get the Specify Find Parameters window. It looks like the following:



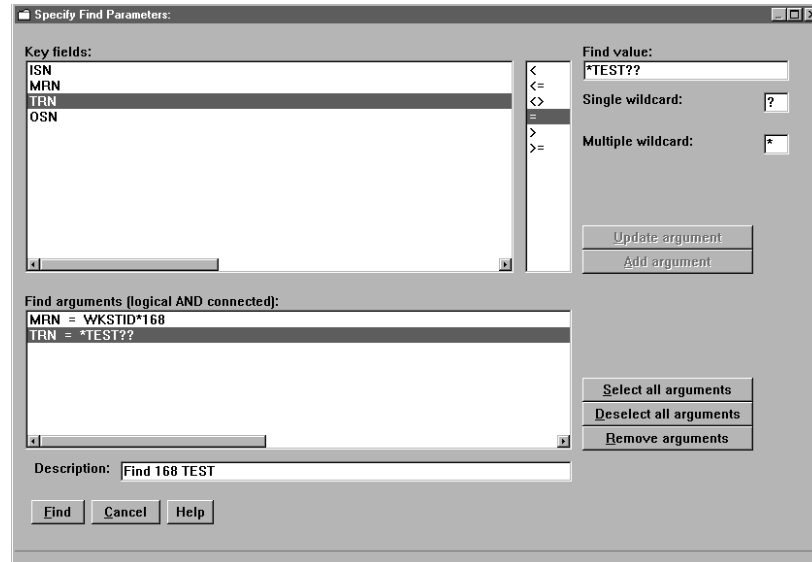

Figure 10. The Specify Find Parameters Window

To specify find arguments:

1. Select a value from the **Key fields** field.

If the MERV Message Processing Client is connected to a MERV Workstation server, the keys are **ISN**, **MRN**, **TRN**, and **OSN** as shown in Figure 10. If the MERV Message Processing Client is connected to a MERV ESA server, up to two keys that are defined for a function are shown. If more than one function is selected, you see only those keys that are valid for all selected functions.

2. Select an operator from the **Operators** field to relate both values.
3. Enter a value in the **Find value** field.

Note that you can add a single wildcard symbol that represents one character, or a multiple wildcard symbol that represents several characters. You can define the wildcard symbols in the **Single wildcard** field and in the **Multiple wildcard** field. Wildcard symbols are supported only for the equals operator (=).

4. Select **Add argument** to save the definition in the **Find arguments** field.

You can repeat this process of adding arguments. If you want to remove one or more saved arguments from the **Find arguments** list, select one or more items and then select **Remove arguments**.

5. Select **Update argument** to replace the definition of the selected argument in the **Find arguments** field.
6. Select **Select all arguments** to select all items in the **Find arguments** field.
7. Select **Deselect all arguments** to deselect all items in the **Find arguments** field.
8. To start the search, select **Find**.

The search arguments are then used to find the messages that match all find arguments.

Note that the find arguments are logically AND connected. For example, if you define the arguments **ISN>100** and **MRN=xyz\***, only those messages that match both arguments are shown.

To close the Specify Find Parameters window without starting the search, select **Cancel**.

The **Description** field allows you to give a name to the list of messages that are found. In the Function List window, this name is shown in the **Description** field. To display only those message lists that match the find arguments, select **All results** from **Display only**. For a detailed description refer to “Defining the Selection for the Functions” on page 25.

### **Minimize**

To shrink to an icon one or more open functions that you select. The function is then still open and available. To display the minimized window in its original size, point to the icon and double-click mouse button 1, or select **Restore** from the **Selected** menu.

### **Restore**

To display the selected minimized window in its original size. You can also point to the icon and double-click mouse button 1.

### **Close**

To close the selected functions.

## **View**

This menu item offers you the following options:

### **Refresh now**

To update changed information within the Function List window, such as the number of messages, to its current status.

### **Sort order**

To sort the functions in ascending or descending alphabetical order.

## **Window**

This menu item offers you the following options:

### **Minimize all**

To shrink to an icon all open functions. The functions are then still open and available.

### **Restore all**

To display all selected minimized windows in their original size.

### **Close all**

To close all open functions.

## **Help**

This menu item offers you the following options:

### **Help index**

To display an alphabetical list of topics for which help information is provided.

### **General help**

To display overview information about the current window.

### **Using help**

To display information on how to use the help facility.

### **Keys help**

To display key assignments for the current window.

## Product information

To display copyright information about the MERVA Message Processing Client.

---

## Defining the Selection for the Functions

The field **Display only** allows you to define the selection for the functions that are to be displayed. You can perform a textual search by entering a specific name, or you can select one of the following items:

**<All>** To display all functions that are defined in your user profile. You can only see functions with which you are allowed to work.

**<All active>**

To display all functions that are opened from this function list.

**<All filled>**

To display all functions that contain messages.

**<All results>**

To display all functions that match the find parameters specified in the Specify Find Parameters window.

**Display**

To display all functions that you are allowed to display.

**Edit**

To display all functions that you are allowed to edit.

**Create**

To display all functions that are not yet completed or to create new messages.

**Authorize**

To display all functions that you are allowed to authorize.

**Retype**

To display all functions that you are allowed to verify.

You can also use wildcard symbols for a textual search:

- Use ? as a single wildcard symbol for a character within the entry field.
- Use \* as a multiple wildcard symbol for several characters within the entry field.

---

## The Function List

This is the main area of the Function List window that contains information about the functions that are shown. You see:

- An icon in the form of a folder that indicates whether the function is open or closed
- The name of the function
- A description of the function contents
- The total number of messages that are contained in the function

The status line shows you the following information:

- Information message ID to locate the message in *Messages and Codes*. To access *Messages and Codes* double-click on the corresponding icon in the MERVA Client window. For details refer to “Starting the MERVA Message Processing Client” on page 7.
- Time at which the function list is last refreshed
- Total number of functions available to you
- Total number of functions that are shown

Note that you can also display a pop-up menu for the function list area. The options of the menu items apply to the selected functions. To start the pop-up menu, place the mouse pointer within the function list area and click mouse-button 2. For a detailed description of the items, refer to “Working with Menu Items” on page 22.

---

## Working with Action and Window Buttons

The action and window buttons of the Function List window allow you to perform actions that are related to the functions and to the active window. The following buttons are provided:

- Open** To display the contents of the selected function.
- Find** To locate messages using specified find parameters. For a detailed description refer to “Selected” on page 22.
- Close** To sign off from the MERVA Message Processing Client. You are asked to confirm the signoff.
- Help** To display overview information about the current window.

---

## Chapter 5. The Message List Window

The Message List window shows you the message list that is contained in the selected function. The message list that is displayed to you contains messages that are stored in queues. Each function has its own queue, the name of which is identical to the respective function.

---

### Understanding the Message List Window Layout

After you open a function in the Function List window, the Message List window is displayed. Note that the window layout and the information that is contained in the window depend on your MERVA system.

The following figure shows an example of the Message List window of MERVA Workstation:

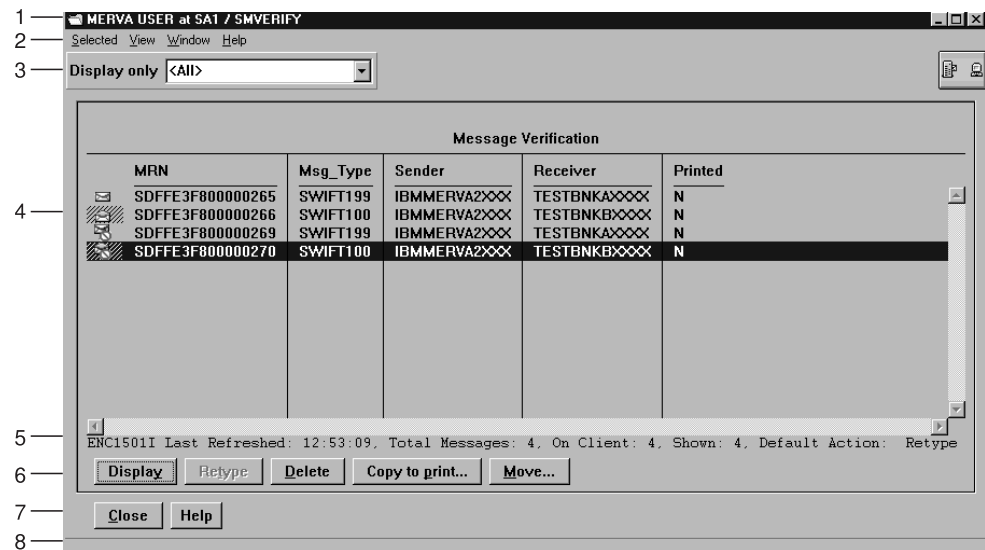

Figure 11. The Message List Window

The Message List window of the MERVA Message Processing Client is divided into different parts:

1. Title bar with window title and activity icon  
The activity icon shows you a server, an envelope, and a terminal. When you issue a request, such as opening a message list, the objects in the icon move to indicate that server communication takes place.
2. Menu bar with menu items **Selected**, **View**, **Window**, and **Help**
3. Selection field **Display only**
4. Message list containing an icon in the form of an envelope, message reference number (MRN), message type, sender of the message, receiver of the message, and print flag.

The message list can also contain an icon in the form of an envelope with an *access-denied* sign. A MERVA Workstation system can be customized in such a way that a user who processes a message cannot authorize or retype this message. In this case, you see an envelope with an *access-denied* sign. The

appropriate action buttons and menu items are then not active. For details on this type of processing a message, refer to the corresponding server customization documentation.

5. Status line
6. Action buttons that depend on user rights and queue settings
7. Window buttons to perform actions related to the active window
8. Information area

With exception of the title bar, these parts are described in detail in the following sections.

---

## Working with Menu Items

Each menu item has a pull-down menu with different options:

### Selected

The contents of this menu item depend on settings for MERVA functions and user rights. The following list in alphabetical order shows you all options available. These options apply to a selected message. If the selected message is already active, the existing message-processing window is shown.

#### **Authenticate**

To start reauthentication of the selected message. After reauthentication completes, the message is routed accordingly. The routing depends on successful or unsuccessful authentication.

#### **Authorize**

To display the Authorize Message window for the selected message.

**Close** To close the selected message.

**Delete** To delete a message.

You are asked to confirm the deletion. Only upon confirmation of the delete request is the message deleted.

#### **Dispatch**

To display the Dispatch Message window for the selected message.

#### **Display**

To display the Display Message window for the selected message.

**Edit** To display the Edit Message window for the selected message.

#### **Mark as failed**

To route the selected message as it is routed when reauthentication fails.

#### **Minimize**

To shrink to an icon the selected message.

**Move** To put a selected message into another queue and delete it from the original one.

**Print** To print a working copy of the selected message. After printing, the **Print** flag of the message is set to **Y**.

#### **Restore**

To display the minimized window of the selected message in its original size.

#### **Retype**

To display the Retype Message window for the selected message.

## View

This menu item offers you the following options:

### **Refresh now**

To update changed information within the Message List window, such as the print status of a message, to its current status. This option is only available if there are no active messages.

### **Sort order**

To sort the messages in ascending or descending order. Each column is changed accordingly.

## Window

This menu item offers you the following options:

### **Minimize all**

To shrink to an icon all open messages. The messages are then still open and available.

### **Restore all**

To display all selected minimized windows in their original size.

### **Close all**

To close all open messages.

## Help

This menu item offers you the following options:

### **Help index**

To display an alphabetical list of topics for which help information is provided.

### **General help**

To display overview information about the current window.

### **Using help**

To display information on how to use the help facility.

### **Keys help**

To display key assignments for the current window.

### **Product information**

To display copyright information about the MERVA Message Processing Client.

---

## Defining the Selection for the Message List

The field **Display only** allows you to define the selection for the messages that are to be displayed. You can perform a textual search by entering a specific name, or you can select one of the following items:

<All> Displays all messages according to the settings in your user profile. You can only see messages with which you are allowed to work.

<All active>

Displays all messages that are opened for message processing.

You can also use wildcard symbols for a textual search:

- Use ? as a single wildcard symbol for a character within the entry field.

- Use \* as a multiple wildcard symbol for several characters within the entry field.

---

## The Message List

This is the main part of the Message List window. Its contents depend on your MERVA system. For MERVA Workstation, for example, it contains an icon in the form of an envelope indicating whether the message is open, closed, or denied for access, the message reference number (MRN), message type, sender of the message, receiver of the message, and print flag. The status line shows you information, such as:

- Information message ID to locate the message in *Messages and Codes*. To access *Messages and Codes* double-click on the corresponding icon in the MERVA Client window. For details refer to “Starting the MERVA Message Processing Client” on page 7.
- Time at which the message list is last refreshed
- Total number of messages available for this function
- Number of messages on the client
- Number of messages that are shown

This number depends on the setting in the **Display only** field.

- Action to be performed by default when you double-click on the message

If you select more than one message, only **Delete**, **Move**, **Copy to Print**, and **Print** are available.

Note that you can also start a pop-up menu for the message list area. The pop-up menu contains options that are currently applicable. These options are identical with the options of the **Selected** menu and apply to a selected message. If the selected message is already active, the existing message-processing window is shown. To start the pop-up menu, point to a specific message and click mouse-button 2. For a detailed description of the options refer to “Actions for Message Processing” on page 48. If you point to an arbitrary point within the message list area and click mouse button 2, you can select or deselect all messages that are shown.

---

## Working with Action and Window Buttons

The action and window buttons of the Message List window allow you to perform actions that are related to the message list and to the active window.

The action buttons that are shown depend on the settings for MERVA functions and user rights. The following list in alphabetical order shows you all options available:

### **Authenticate**

To start reauthentication of the selected message. After reauthentication completes, the message is routed accordingly. The routing depends on successful or unsuccessful authentication.

### **Authorize**

To display the Authorize Message window for the selected message.

### **Copy to Print**

To copy a message to a print queue.

**Create** To display the Select Message Type window.

**Delete** To delete a message.



You are asked to confirm the deletion. Only upon confirmation of the delete request is the message deleted.

**Dispatch**

To display the Dispatch Message window for the selected message.

**Display**

To display the Display Message window for the selected message.

**Edit**

To display the Edit Message window for the selected message.

**Mark as failed**

To route the selected message as it is routed when reauthentication fails.

**Move**

To put a selected message into another queue and delete it from the original one.

**Print**

To print a working copy of the selected message. After printing, the **Print** flag in the MERVA-related data of the message is set to **Y**.

**Retype**

To display the Retype Message window for the selected message.

**Templates**

To display the Maintain Templates window to select or specify a template.

The following window buttons are valid:

**Close**

To close the Message List window without performing an action and return to the Function List window.

**Help**

To display overview information about the current window.



---

## Chapter 6. Working with Message-Processing Windows

The message-processing windows display the contents of a message. The message consists of fields, subfields, sequences, repeatable sequences, and other parts. It is formatted to help you enter data efficiently in these message parts. The message-processing windows also provide functions to vary the amount of data that is shown and to check the message for correctness. This chapter shows you how to work with these functions.

---

### General Description

The following sections give you an overview of the functions available to you.

#### Understanding the Structure of a Message Part

Several types of fields are available.

- Mandatory fields and subfields

Fields that are preceded by an asterisk (\*). For example, fields that contain at least one mandatory subfield, are mandatory. You must fill them in to complete the message.

Depending on the contents of the message, additional fields might become mandatory. These fields are found when you check the message.

- Sequences

Fields can be combined into sequences. Each sequence is contained in an outline box and has a push button to expand or collapse it.

An expanded sequence that is indicated by a minus sign (-) shows you either a header line and all fields, or a header line and only those fields that contain data.

A collapsed sequence that is indicated by a plus sign (+) shows you only the header line.

- Repeatable Sequences

A repeatable sequence is a field or group of fields that can be successively entered in a message more than once. Each repetition of a repeatable sequence is called an *occurrence*.

Repeatable sequences are displayed in a similar way as notebooks in which each occurrence occupies a notebook page. You can expand or collapse repeatable sequences in the same way as sequences. You can also browse through the occurrences by selecting an occurrence with the spin button.

If you are in the edit mode and enter data in the last empty page, at the end of this page another empty page is automatically created.

#### Navigation Elements

In a message with fields that you can edit, the cursor is automatically located in the first field in which you can enter data. To move the cursor to the next field in which you can enter data, press the Tab key or use the mouse.

For mandatory fields that are empty or for fields that contain incorrect data, you get a warning message:

- When you select **OK**, the cursor is located in the previous field. You can then correct the data.

- When you select **Cancel**, the cursor remains where it was. The warning message is ignored.

To scroll through the message, use the Page Up and Page Down keys.

## Entering Data in S.W.I.F.T. Messages

The MERVA Message Processing Client lets you enter, display, check, and handle message data in different ways. You can, for example:

- Fill option fields automatically.
- Select different display modes for repeatable sequences.
- Move from field to field automatically.
- Switch off intermediate field checking.

For a detailed description on how to customize these options, refer to “Changing Settings” on page 10.

You must enter data in the message fields in the format specified in the *S.W.I.F.T. User Handbook* with the following exceptions for option fields, Bank Identifier Code (BIC) fields and amount fields:

- Option fields

Some fields contain options as first subfields. These options define the layout of the remaining field that can vary for different options. You must enter the option before you can enter other data. The layout of the field might then change.

- BIC fields

In these fields, you can:

- Enter a nickname for a financial institution.

When you then press Tab, the nickname is replaced with the BIC code. At the same time, the address information that is found in the correspondents database is expanded.

- Enter a BIC of a financial institution.

When you then press Tab, the address information that is found in the correspondents database is expanded.

- Double-click or press **Ctrl + P** to prompt for possible BIC information.

You then get the Prompt window. For a detailed description of this window refer to “Working with the Prompt Codewords Window” on page 35.

During a session, the data that is retrieved from the server is stored in a cache. For example, if currency data is changed on the server, you must sign off from the client and sign on again to see the data changed.

- Amount fields

You can use abbreviations to specify amounts in the amount field, such as:

- **T** for thousand

For example, instead of **10000**, you can type **10T**.

- **M** for million

For example, instead of **20000000**, you can type **20M**.

- You can enter the amount with or without delimiters, for example, **1523,50** is equivalent to **1.523,50**. Both entries are shown as **1.523,50**.

## Authentication Checking

When you enter the BIC code of the receiver's LT in the S.W.I.F.T. application header of a message, the MERVA server checks whether an authentication check for the sender's and receiver's LTs is to be performed. If authentication keys are not available, you get a warning.

During a session, the data that is retrieved from the server is stored in a cache. For example, if currency data is changed on the server, you must sign off from the client and sign on again to see the data changed.

If authentication checking is not active on the MERVA server, the check is not performed.

## Working with the Prompt Codewords Window

Some fields allow you to enter only defined values, such as:

- Currency code
- Codeword

Subfields that allow you to prompt for the possible values are indicated by color according to the user settings.

To get the prompt window with a list of values that you can select, double-click on a subfield that is enabled for prompting or enter **Ctrl + P**. Note that for codewords the list of values might also depend on the message type.

The following figure shows you an example of a Prompt Codewords window:

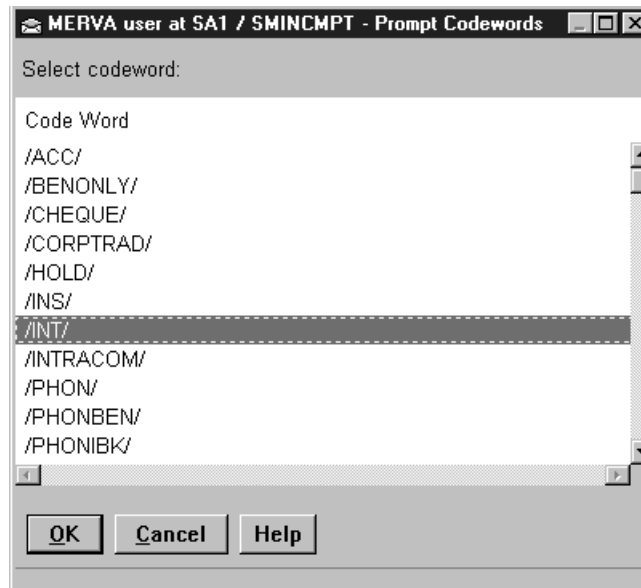

Figure 12. Example of a Prompt Codewords Window

You can select **OK** to enter the selected value in the field that is enabled for prompting. You can also select **Cancel** to close the Prompt Codewords window without selecting a value.

## Working with the Prompt Correspondent Window

In some fields you must enter correspondent information. These fields allow you to prompt for the information by showing you the Prompt Correspondent window. In this window you can search for a correspondent in the correspondents database of the server.

The following figure shows you an example of a Prompt Correspondent window:

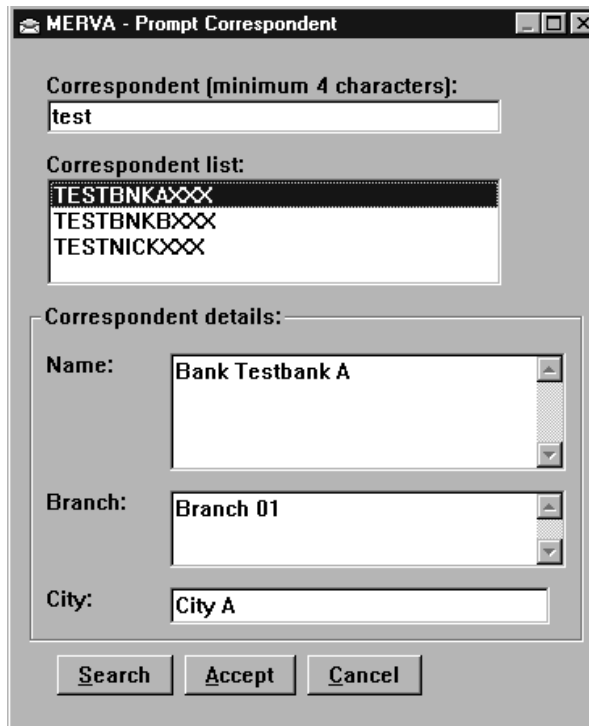

Figure 13. Example of a Prompt Correspondent Window

To start the search:

1. In the **Correspondent** field, specify the value for which you want to search in the correspondents database.

**Note:** You must enter at least four characters.

2. Select **Search** to start the search in the correspondents database.

After the search is completed successfully, you see the search results in the **Correspondent list** list box. You can scroll through the list to select a correspondent.

In the **Correspondent details** field, you can see details of the selected correspondent.

3. Select **Accept** to use the selected correspondent for further processing within message processing.

## Working with the Clipboard

The **Edit** toolbar contains the toolbar buttons **Cut**, **Copy**, and **Paste**.

These buttons and the corresponding menu items of the **Edit** menu are dynamically enabled:

- **Cut** is enabled if you are in the edit mode and if text is selected.
- **Copy** is enabled if text is selected.
- **Paste** is enabled if the clipboard contains text.

## Displaying only Fields with Data

You can change the amount of information that is displayed to you by:

- Expanding or collapsing message parts
- Displaying only fields that contain data

For details on how to expand or collapse sequences and repeatable sequences, refer to “Understanding the Structure of a Message Part” on page 33.

You can also expand or collapse all sequences or repeatable sequences of the complete message part by using the toolbar buttons or the corresponding menu items of the **View** menu.

By selecting or deselecting **Display only fields with data** you can define to display only fields with data or to display the complete message.

## Checking Errors

Whenever you move to a new field by pressing Tab or by positioning the cursor, MERVA checks that the data entered in the previous field is correct. If an error occurs, an action message is shown.

Some fields depend on entries that are made in other fields. This cross-field checking for errors is done when you select **Accept**, **Accept with parameters**, **Check**, or **Route to telex** from the **Message** menu or from the action buttons. When an error is found, you get the Checking Errors window. It shows you a list of all errors that are found. The window looks like the following:

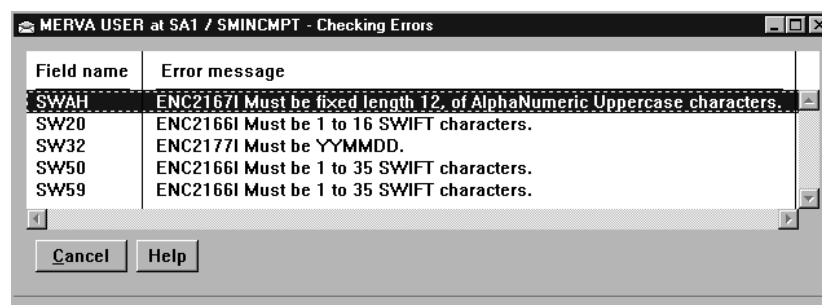

Figure 14. An Example of the Checking Errors Window

The **Field name** field shows you the identification of the field where the error occurs.

The **Error message** field shows you error message ID and error reason.

When you double-click on the error message that is shown, the cursor is positioned to the part of the message that causes the error. You can correct the error, and accept or check the message. You can also correct the error later.

## Understanding the Text View of a Message Body

The message body is usually displayed in a formatted way according to the message type that it represents. This allows you to enter data without knowing the network structure of the message. If a message cannot be formatted correctly, however, it is necessary to display the network structure of the message.

If the message cannot be formatted, the message body is automatically displayed in network format, also called *text view*. You then get an error message that indicates the formatting error. By default, the cursor is positioned at the place where the error occurs. The following figure shows you an example of a text view of a message that cannot be formatted correctly.

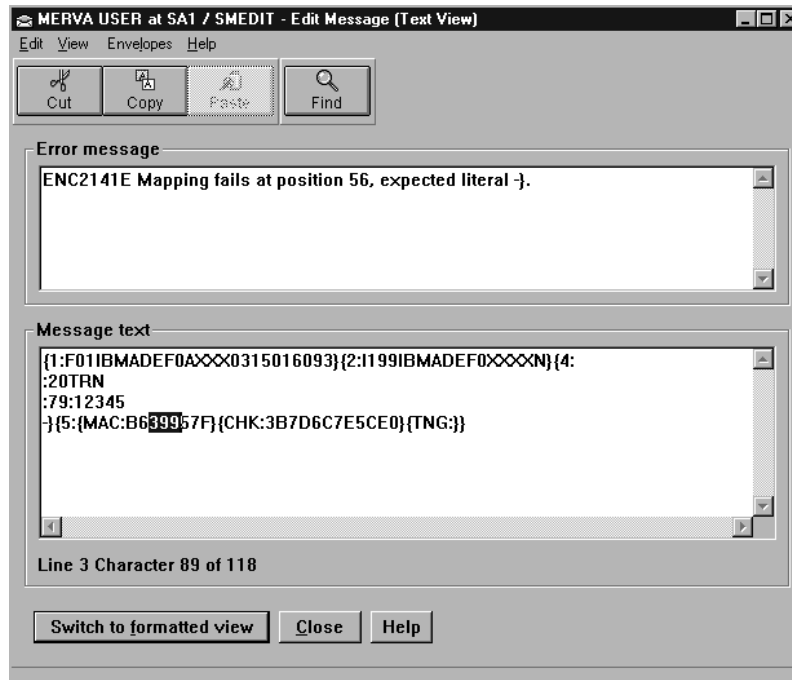

Figure 15. An Example of the Text View Window

Working with the text view of a message allows you to correct the message and to retry formatting. Note that you cannot change the message type and for S.W.I.F.T. messages the LT addresses when you work in the text view mode.

The display of the text view of a message is only done automatically if a message cannot be formatted correctly. You can, however, for any message except for the **Retype Message** function, select **Switch to text view** from the **View** menu.

The following figure shows you the standard Text View window.



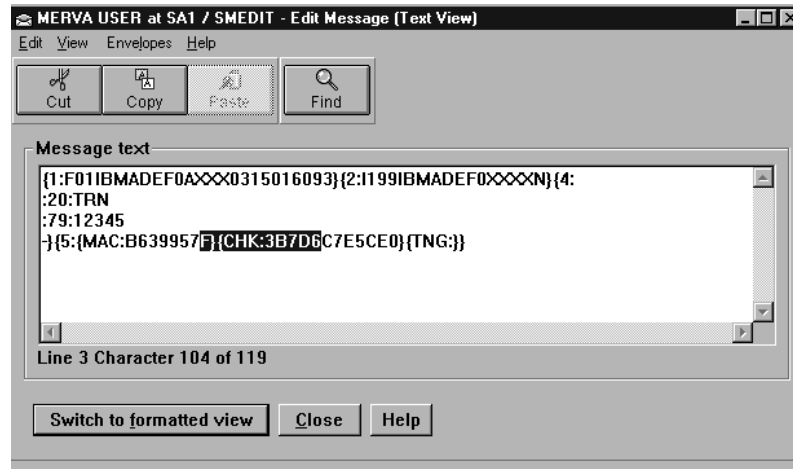

Figure 16. Standard Text View Window

The Text View window consists of several parts:

### Menu Bar

The menu bar of the Text View window contains the following options:

- Edit
- View
- Envelopes
- Help

When you create or edit a message, you can select the following options from the **Edit** menu. When you do not create or edit a message, only **Copy** is available.

**Cut** To move marked data to the clipboard.

**Copy** To copy marked data to the clipboard.

**Paste** To place data that you have cut or copied.

**Find** To open the Find window. For a detailed description refer to “Finding Text in the Text View” on page 40.

You can select the following options from the **View** menu:

#### Show MERVA-related data

To display the MERVA-Related Data window with information that is assigned to the message by MERVA.

#### Switch to formatted view

To redisplay the message body in formatted view if the message can be formatted correctly.

You can select the following option from the **Envelopes** menu:

**Telex** To send a message as a telex.

When you select this option, MERVA assigns a telex envelope to the message. You can only select this option if your user profile has the authorization to create a telex. You can only deselect this option if your user profile has the authorization to remove a telex envelope. When you deselect this option, the telex envelope is removed from the message.

You can select the following options from the **Help** menu:

**Help index**

To display an alphabetical list of topics for which help information is provided.

**General help**

To display overview information about the current window.

**Using help**

To display information on how to use the help facility.

**Keys help**

To display key assignments.

**Product information**

To display copyright information about the MERVA Message Processing Client.

**Message Text**

The message text contains the message body in network format. For the functions **Create Message**, **Edit Message**, or **Edit Template**, the text can be changed. For all other functions, except for **Retype Message**, the text can be viewed.

At the bottom of the message text area, you see information according to the current cursor position. The shown line and character numbers indicate the number of lines and characters between the beginning of the displayed message body and the cursor.

**Action and Window Buttons**

The following action and window buttons are valid:

**Switch to formatted view**

To redisplay the message body in formatted view if the message can be formatted correctly.

**Reject** To mark a message as rejected during a verification step or an authorization step and route it to further message-processing functions, such as edit.

When you select **Reject**, you automatically get a comment field as part of the MERVA-related data. In this field, you can enter a reason why you reject the message or leave the comment field unchanged.

**Close** To close the Text View window without performing an action.

**Help** To display overview information about the current window.

**Information Area**

The information area shows information about the selected item or about the choice on which the cursor is .

**Finding Text in the Text View**

In complex messages, it is difficult to find specific data in the text view. To help you find specific text, MERVA offers you the Find Text window that allows you to search for text parts, such as phrases, words, or word fragments. The search process is similar to that of a text editor.

You can search in ascending or descending order. You can start the search from the current cursor position, from the top of the message, or from the bottom of the message.

If you start searching in ascending order from the top of the message, the cursor is positioned at the corresponding hit after each search for the string. This procedure is repeated until the last hit is found. The same applies if you start searching in descending order, or from the current cursor position.

The following figure shows you the Find Text window with an example.

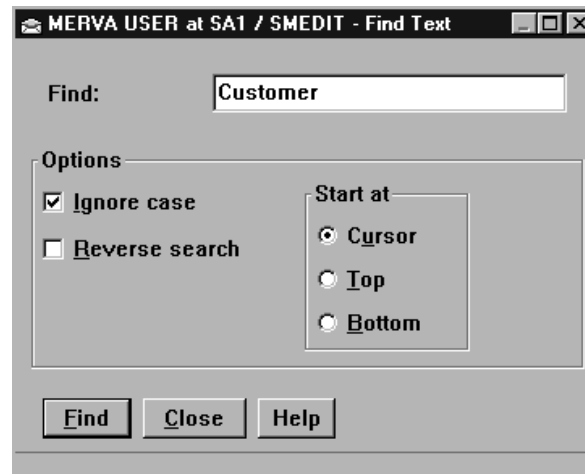

Figure 17. Find Text Window

The Find Text window consists of several parts:

**Find** In this field you type the text you want to locate.

**Options**

Select **Ignore case** to locate text in uppercase and lowercase letters, no matter how you have typed it. For example, “Bank”, “bank”, and “BANK” is treated the same. This item is selected by default.

Select **Reverse search** to search from the position that is defined in the **Start at** field to the beginning of the text.

**Start at**

To specify the start position of the search.

The following action and window buttons are valid:

**Find** To start the search for the string specified in the **Find** field. If no other piece of data with the same information is found, this is indicated in the information area.

**Close** To close the Find Text window without performing an action.

**Help** To display overview information about the current window.

---

## Message Parts

A message consists of the message body, MERVA-related data, and optionally of telex envelope and MERVA Link envelope. The following sections describe the MERVA-related data and the MERVA Link envelope. For details on the telex envelope refer to “Chapter 13. Processing Telex and Free Format Messages” on page 85.

## MERVA-Related Data

MERVA-related data contains data that MERVA assigns to a message to control and monitor the message flow. This data is not sent via a network. The data depends on the operating system that is used by the attached MERVA server. For details refer to the corresponding *User's Guides* of the MERVA servers.

The following list shows you all MERVA-related data available:

### Message reference

A number that is assigned by MERVA to identify the message. For MERVA Workstation, the number is called *Message Reference Number* (MRN). The MRN is 16 characters long. For MERVA ESA, this number is the *Unique Message Reference* (UMR). The UMR is 22 characters long.

### Message entry date

This field is only valid for MERVA Workstation. It shows the date on which the message is created, copied, or received in the form of **YYYY-MM-DD**.

### Message entry time

This field is only valid for MERVA Workstation. It shows the time on which the message is created, copied, or received in the form of **HH:MM.SSSSSS**.

### Print flag

This field is only valid for MERVA Workstation. **Y** indicates that the message was printed. **N** indicates that the message was not printed.

### Last user

This field is only valid for MERVA Workstation. It shows the user ID of the last user who changed the message.

### Date last modified

This field is only valid for MERVA Workstation. It shows when the message was last changed in the form of **YYYY-MM-DD**.

### Sequences S.W.I.F.T. information

The following fields are only available for S.W.I.F.T. messages:

#### Message acknowledgment

This field contains the acknowledgment information **ACK** or **NAK**.

For detailed information about the NAK codes refer to the Online Help of the MERVA Message Processing Client.

#### Authentication (MAC)

This field contains the message authentication code (MAC) information.

#### Proprietary authentication (PAC)

This field contains the proprietary authentication code (PAC) information.

### Comment

In this field you can attach a comment, for example, the reasons for rejecting a message during verification or authorization. This field is the only MERVA-related data field that you can edit.

### Reconciliation key

This field is only available for MERVA ESA. For details refer to *MERVA Traffic Reconciliation*.

### Sequence trace entry

This field contains an entry with trace information. For MERVA Workstation, only the latest trace entry is available. For MERVA ESA, a list of trace entries is shown as a notebook.

The trace entry consists of:

**User** This field shows the user ID of the last user who worked with the message, for example, the last user authorizing the message.

#### **Function**

This field shows the MERVA function that is active when the trace entry is written.

**Error** This field shows the error code. If no error code exists, this field is empty.

**Date** This field shows the date on which the trace entry is written in the form of **YYYY-MM-DD**.

**Time** This field shows the time at which the trace entry is written in the form of **HH:MM**.

### Sequence Message Acknowledgment Explanation

If the field **Message acknowledgment** contains a S.W.I.F.T. acknowledgment message, the sequence explains the delivered acknowledgment code in textual form.

The message acknowledgment explanation consists of:

**Status** This field shows you whether the S.W.I.F.T. acknowledgment is positive or negative. If the acknowledgment is negative, the status message contains the returned S.W.I.F.T. NAK code and the number of the incorrect message net format line.

**Explanation** This field explains the returned S.W.I.F.T. NAK code in textual form.

The following figure shows you an example of a MERVA-Related Data window:

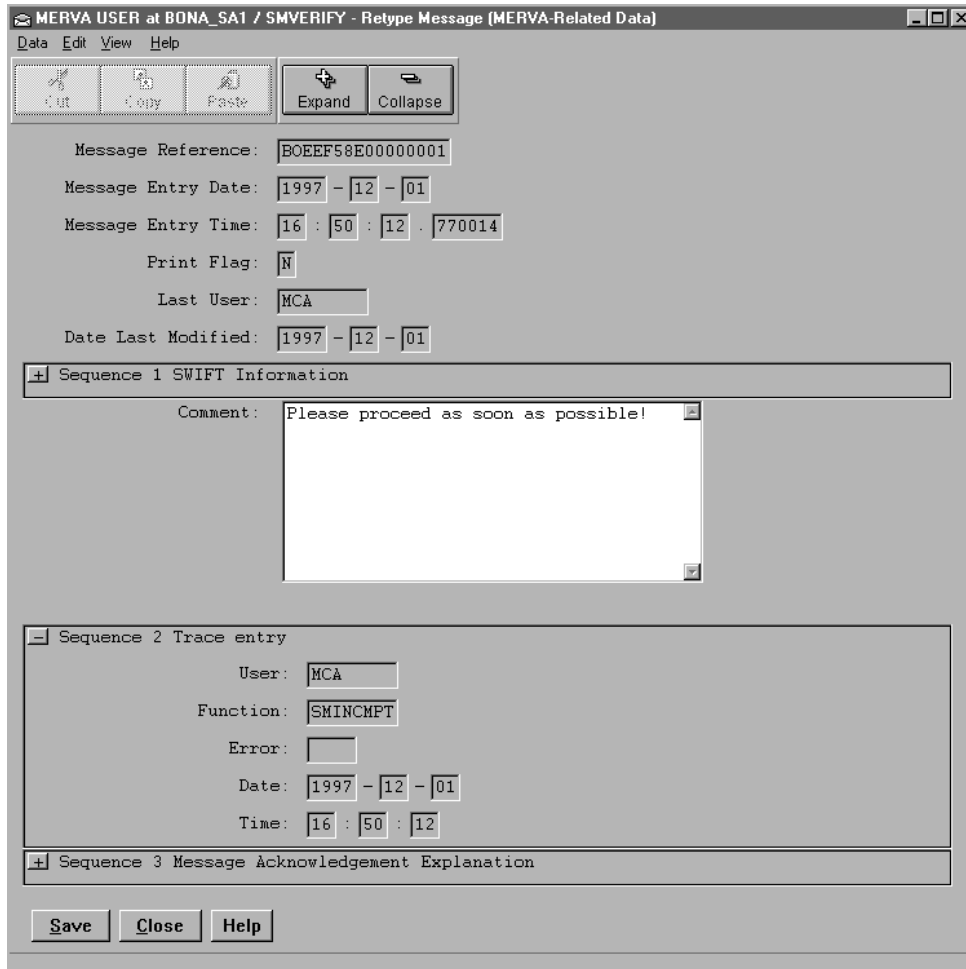

Figure 18. MERVA-Related Data Window

The MERVA-Related Data window consists of several parts:

### Menu Bar

The menu bar of the MERVA-Related Data window contains the following options:

- Data
- Edit
- View
- Help

When you can edit fields, you can select the following options from the **Data** menu. When you cannot edit fields, only **Close** is available.

**Save** To save the MERVA-related data.

**Close** To close the MERVA-Related Data window without saving any changes.

When you can edit fields, you can select the following options from the **Edit** menu. When you cannot edit fields, only **Copy** is available.

**Cut** To move marked data to the clipboard.

**Copy** To copy marked data to the clipboard.

**Paste** To place data that you have cut or copied.

You can select the following options from the **View** menu:

**Display only fields with data**

To display only fields that contain data. Empty fields are hidden.

**Expand all sequences**

To display all lower-level data for every sequence that can be expanded at one time.

**Collapse all sequences**

To hide all lower-level data for every sequence that is expanded.

You can select the following options from the **Help** menu:

**Help index**

To display an alphabetical list of topics for which help information is provided.

**General help**

To display overview information about the current window.

**Using help**

To display information on how to use the help facility.

**Keys help**

To display key assignments.

**Product information**

To display copyright information about the MERVA Message Processing Client.

**Action and Window Buttons**

The following action and window buttons are valid:

**Save** To save the MERVA-related data. This action button is only available if you can edit fields.

**Close** To close the MERVA-Related Data window without saving any changes.

**Help** To display overview information about the current window.

## Telex Envelope

For details on the telex envelope refer to “Chapter 13. Processing Telex and Free Format Messages” on page 85.

## MERVA Link Envelope

The MERVA Link envelope contains data that MERVA assigns to a message when the message is sent via the MERVA Link feature. You cannot change this data.

The following list shows you all data available:

**IAM identifier**

This field shows the IAM message identifier. This identifier is identical for all messages that are transferred via MERVA Link.

**Originating node name**

This field shows the MERVA Link node name.

**Originating application name**

This field shows the Application Support Program (ASP) name.

The following figure shows you an example of MERVA Link data:

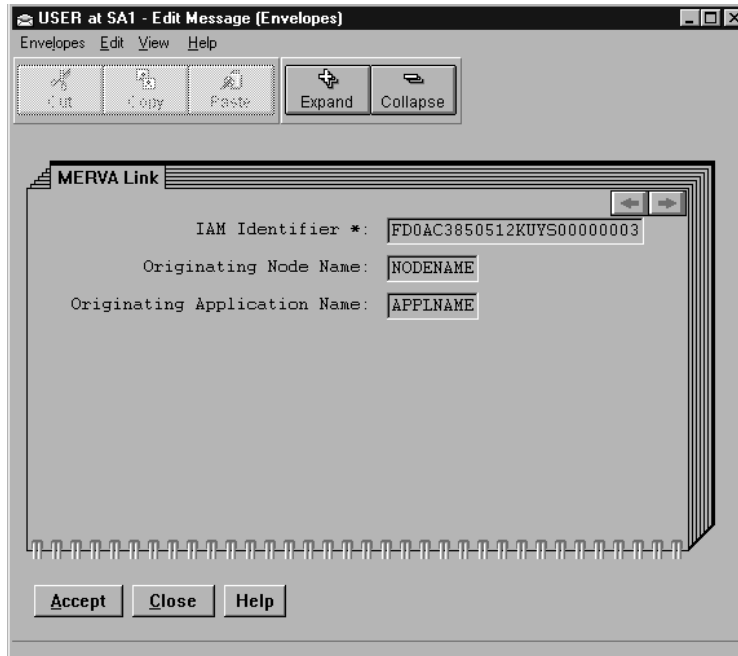

Figure 19. MERVA Link Data

## Envelopes View

The envelopes view contains the optional envelopes for telex and MERVA Link.

The following figure shows you an example of a telex envelope:



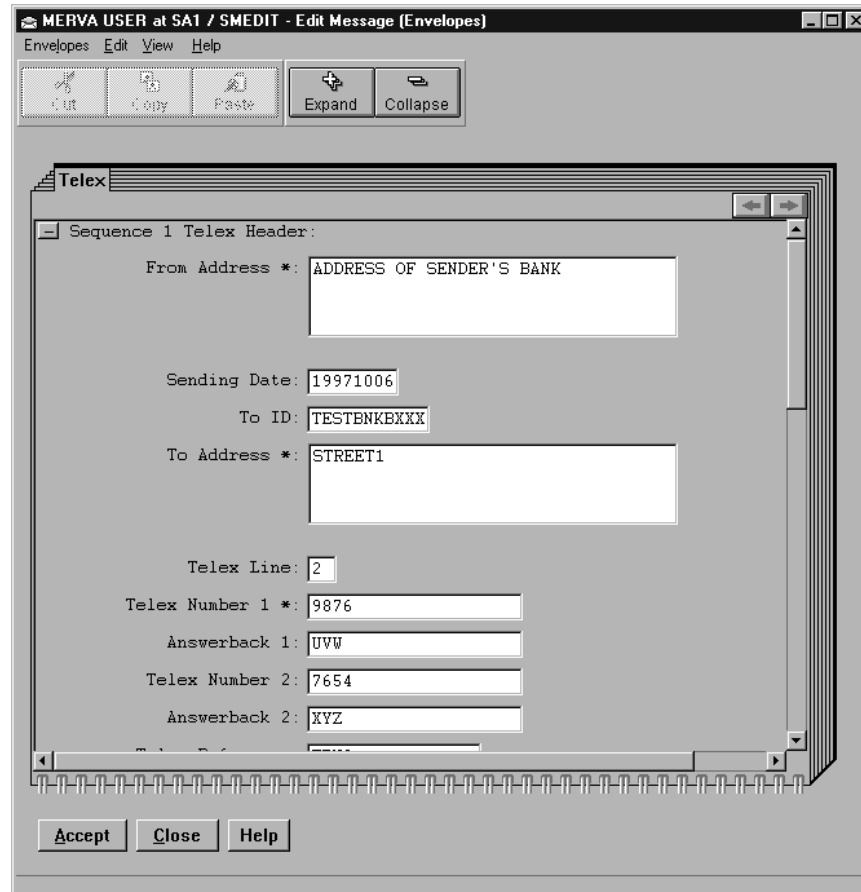

Figure 20. An Example of a Telex Envelope

An envelope consists of several parts:

### Menu Bar

The menu bar of the Envelopes View window contains the following options:

- Envelopes
- Edit
- View
- Help

When you are in an edit mode, you can select the following options from the **Envelopes** menu. When you are not in an edit mode, only **Check** and **Close** is available.

#### Accept

To check and save the envelopes data.

**Check** To check the envelopes data.

**Save** To save the envelopes data.

**Close** To close the current window without saving any changes.

When you are in an edit mode, you can select the following options from the **Edit** menu. When you are not in an edit mode, only **Copy** is available.

**Cut** To move marked data to the clipboard.

**Copy** To copy marked data to the clipboard.

**Paste** To place data that you have cut or copied.

You can select the following options from the **View** menu:

**Display only fields with data**

To display only fields that contain data. Empty fields are hidden.

**Expand all sequences**

To display all lower-level data for every sequence that can be expanded at one time.

**Collapse all sequences**

To hide all lower-level data for every sequence that is expanded.

You can select the following options from the **Help** menu:

**Help index**

To display an alphabetical list of topics for which help information is provided.

**General help**

To display overview information about the current window.

**Using help**

To display information on how to use the help facility.

**Keys help**

To display key assignments.

**Product information**

To display copyright information about the MERVA Message Processing Client.

**Action and Window Buttons**

The following action and window buttons are valid:

**Accept**

To check and save the envelopes data. This action button is only valid if you can edit fields.

**Save**

To save the envelopes data. This action button is only available if you can edit fields.

**Close**

To close the current window without saving any changes.

**Help**

To display overview information about the current window.

---

## Actions for Message Processing

The options that you see in the **Message** menus of the message-processing windows depend on the settings for:

- MERVA functions
- User rights

The following list shows you all options available for message processing.

**Accept**

To complete a message after you enter your data and route it to the next message-processing function.

When you select **Accept**:

- The message is checked for errors.  
If an error is found, you get the Checking Errors window. You can correct the error, and accept or check the message. You can also correct the error later.  
If no error is found, the message is routed to the queue of the next message-processing function.
- If the message contains envelopes, the envelopes are also checked.

#### **Accept with parameters**

To complete a message including parameters and route it to the next message-processing function.

When you select **Accept with parameters**:

- The message is checked for errors.  
If an error is found, you get the Checking Errors window. You can correct the error, and accept or check the message. You can also correct the error later.  
If no error is found, you are asked to enter the parameters. If you select **OK** after you enter the parameters, the message is routed to the queue of the next message-processing function. If you select **Cancel**, no action is performed, and the message window remains open.
- If the message contains envelopes, the envelopes are also checked.

#### **Authenticate**

To start reauthentication of the selected message. After reauthentication completes, the message is routed accordingly. The routing depends on successful or unsuccessful authentication.

**Check** To check a message.

When you select **Check**:

- The message is checked for errors.  
If an error is found, you get the Checking Errors window. You can correct the error, and accept or check the message. You can also correct the error later.
- If the message contains envelopes, the envelopes are also checked.

**Close** To close the current window.

- When you select **Close** while creating a message, the creation process ends. New messages are deleted and existing messages remain unchanged.
- When you select **Close** while editing, authorizing, or retyping a message, the respective process ends. The message remains where it was without a change.

If the contents of the message is changed, you are asked to confirm closing of the current window.

#### **Copy to print**

To copy a message to a print queue.

If more than one print queue exists, you get a list of all defined print queues from which you can select a queue.

For details refer to “Chapter 12. Printing Messages” on page 83.

**Delete** To delete a message.

You are asked to confirm the deletion. Only upon confirmation of the delete request is the message deleted.

**Delete by routing**

To delete a message by routing it to a queue.

The message is marked as deleted and routed according to your routing conditions.

**Mark as failed**

To route the selected message as it is routed when reauthentication fails.

**Move** To put a message into another queue and delete it from the original one.

**Print** To print a working copy of the message. After printing, the **Print** flag of the message is set to **Y**.

For details refer to “Chapter 12. Printing Messages” on page 83.

**Reject** To mark a message as rejected during a verification step or an authorization step and route it to further message-processing functions, such as edit.

When you select **Reject**, you automatically get a comment field as part of the MERVA-related data. In this field, you can enter a reason why you reject the message or leave the comment field unchanged.

**Replace**

To return a message with all changes to the queue without checking for errors.

**Requeue**

To place a message at the end of the queue without checking for errors.

**Route to edit**

To route a message to the edit queue.

**Route to telex**

To route a message to the telex queue.

If more than one telex queue exists, you get a list of all telex queues from which you can select a queue.

**Save** To save an incomplete message.

The message is saved and stays in the create queue.

**Save as template**

To save the currently displayed message as a template to reuse its data.

For MERVA Workstation, a secondary window, Specify Template Name and Description, is displayed. The window looks like the following:

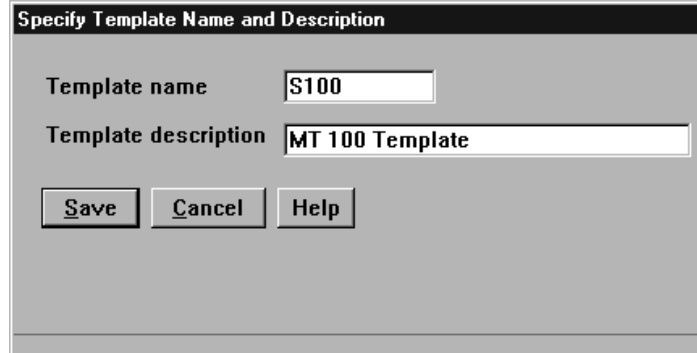

*Figure 21. The Specify Template Name and Description Window*

For MERVA ESA, this window is not displayed. Template name and description are created by the server system according to its definitions.



---

## Chapter 7. Creating Messages

You use the create function to:

- Create S.W.I.F.T. messages in categories 1 to 9, as defined in the *S.W.I.F.T. User Handbook*.
- Create S.W.I.F.T. system messages in the categories GPA System Messages and FIN System Messages, as defined in the *S.W.I.F.T. User Handbook*.

The creation of new messages is described in “Working with the Create Message Window” on page 55.

- Create a S.W.I.F.T. message to send as a telex.

The creation of S.W.I.F.T. messages for telex transmission is described in “Creating a S.W.I.F.T. Message for Telex Transmission” on page 60.

- Complete unfinished messages.

How to complete unfinished messages is described in “Chapter 10. Editing Messages” on page 73.

- Create and use template messages.

The creation and use of template messages are described in “Creating a Message by Using a Template” on page 59.

- Create telex messages and free format messages.

The creation and use of telex messages and free format messages are described in “Chapter 13. Processing Telex and Free Format Messages” on page 85.

---

### Creating a New Message

The MERVA Message Processing Client allows you to create different kinds of messages, such as S.W.I.F.T. Financial Messages and S.W.I.F.T. System Messages.

When you select **Create** in the Message List window, the Select Message Type window is the first window that is displayed to you. It shows you all message types that you are allowed to create in hierarchical order. It also shows you all template types that you are allowed to use. This window looks like the following:

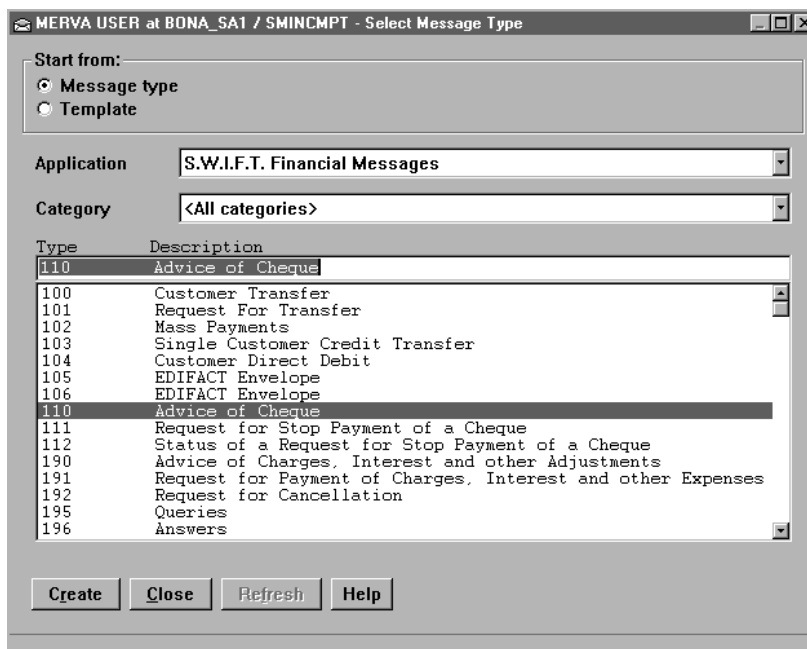

Figure 22. The Select Message Type Window

The Select Message Type window of the MERVA Message Processing Client is divided into several parts:

The **Start from** field, where you choose to:

- Create new messages by selecting a message type.
- Create a new message by selecting a predefined template.

For a detailed description refer to “Creating a Message by Using a Template” on page 59.

The **Application** list denotes the message applications available to you. You can choose:

- S.W.I.F.T. Financial Messages in categories 1 to 9, as defined in the *S.W.I.F.T. User Handbook*
- S.W.I.F.T. System Messages in the categories GPA System Messages and FIN System Messages, as defined in the *S.W.I.F.T. User Handbook*
- General messages, such as free format message or telex message

The **Category** list shows you the name and description of the message categories that are contained in the selected application. Each category contains different message types, for example, S.W.I.F.T. category 1 contains the message types 100 to 199. The default setting **<All categories>** allows you to enter a message type in the entry field of the type list that can belong to any category of the selected application.

The **Type** list shows you the key that identifies the message. The **Description** list shows you the description of the messages that are assigned to the selected category type.

Note that the contents of these fields depend on the rights that are assigned to you. The examples that are shown describe all messages available.

The following action and window buttons are available:



**Create** To create a new message and display the Create Message window.

**Close** To close the Select Message Type window without creating a message.

**Refresh**

To refresh the list of templates. This button is only active when you work with templates.

**Help** To display overview information for the current window.

To create a new message:

- Select **Message type** in the field **Start from**. This is the default selection.
- Select an application from the **Application** field.
- Select a category from the **Category** field.
- Specify a message type in one of the following ways:
  - Enter the message type.  
For example, enter **100** to create a customer transfer that belongs to the S.W.I.F.T. category 1, Customer Payments & Cheques.
  - Select a message type from the **Type** list box.
- Select **Create** to get the Create Message window where you can enter the message text.

---

## Working with the Create Message Window

Depending on your selection in the **Start from** field, this window shows an empty message body or the message body of the selected template.

The following figure shows you an example of a message with an empty message body.

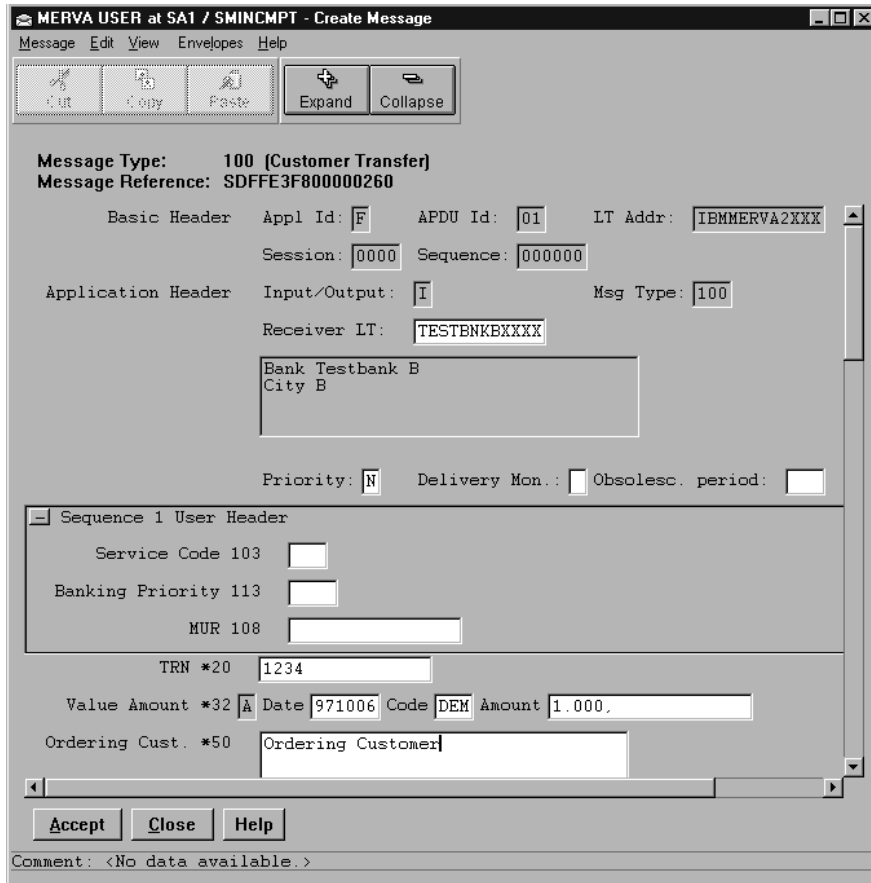

Figure 23. The Create Message Window

The message consists of these parts:

- Message body with message fields containing the message text as shown in Figure 23
- MERVA-related data containing data that MERVA uses while processing the message

You can see this data when you select **Show MERVA-related data** from the **View** menu.

- Message envelopes assigned to the message body to send messages via telex network or MERVA Link

If available, you can see the envelopes when you select **Show message envelopes** from the **View** menu.

The information area shows you the following:

- Comment
  - If no comment is available, you see the text **Comment: <No data available.>**.
  - If a comment is available, you see the first part of the comment.
- Acknowledgment information
  - If this information is available, you see the first part of the message acknowledgment field for S.W.I.F.T. messages.
- General information
  - Shows you information about the selected menu item or the choice on which the cursor is.

You can see the complete information in the MERVA-Related Data window. For details refer to “MERVA-Related Data” on page 42.

How you enter data in the message fields is described in “Chapter 6. Working with Message-Processing Windows” on page 33.

## Working with Menu Items

The menu bar of the Create Message window contains the following entries:

- Message
- Edit
- View
- Envelopes
- Help

### Message

The options that you can select from the **Message** menu depend on the settings for:

- MERVA functions
- User rights

For a detailed description of all options available refer to “Actions for Message Processing” on page 48.

### Edit

You can select the following options from the **Edit** menu:

**Cut** To move marked data to the clipboard.

**Copy** To copy marked data to the clipboard.

**Paste** To place data that you have cut or copied.

### Delete data from message

To delete a specific subfield or a complete segment of data.

A secondary window shows you the choice for deletion that depends on the position of the cursor. For example, if the cursor is positioned in a subfield of an occurrence of a repeatable sequence, you can delete the following data:

- Current subfield
- Field
- Data area
- Occurrence
- Complete repeatable sequence

### Insert an occurrence

To insert one occurrence of a repeatable sequence.

A secondary window shows you occurrences of repeatable sequences that you can insert as an empty occurrence.

### View

You can select the following options from the **View** menu:

#### Show MERVA-related data

To display the MERVA-Related Data window with information that is assigned to the message by MERVA.

**Show message envelopes**

To display the Message Envelope window that contains message envelopes assigned to the message body.

The following message envelopes are valid:

- Telex

If the message is to be sent via the telex network or is received with a telex envelope.

- MERVA Link

Assigned by MERVA if the message is received via MERVA Link.

If no envelope exists, this item is not active.

**Display only fields with data**

To display only fields that contain data. Empty fields are hidden.

**Expand all sequences**

To display all lower-level data for every sequence that can be expanded at one time.

**Collapse all sequences**

To hide all lower-level data for every sequence that is expanded.

**Switch to text view**

To display the message body in network format.

**Envelopes**

You can select the following option from the **Envelopes** menu:

**Telex** To send a message as a telex.

When you select this option, MERVA assigns a telex envelope to the message. You can only select this option if your user profile has the authorization to create a telex. You can only deselect this option if your user profile has the authorization to remove a telex envelope. When you deselect this option, the telex envelope is removed from the message.

**Help**

You can select the following options from the **Help** menu:

**Help index**

To display an alphabetical list of topics for which help information is provided.

**General help**

To display overview information about the current window.

**Using help**

To display information on how to use the help facility.

**Keys help**

To display key assignments.

**Product information**

To display copyright information for the MERVA Message Processing Client.

## Working with Action and Window Buttons

The action and window buttons of the Create Message window allow you to perform actions that are related to the message and to the active window.

The action buttons that are shown depend on the settings for:

- MERVA functions
- User rights

For a detailed description of all options available refer to “Actions for Message Processing” on page 48.

The following window buttons are valid:

- Close** To close the Create Message window without performing an action and return to the Message List window.
- Help** To display overview information for the current window.

---

## Creating a Message by Using a Template

A template usually contains information that is reused on a regular basis. It serves as an outline that you can use to create a finished message of this type.

When you select **Template** in the **Start from** field, the Select Message Type window looks like the following:

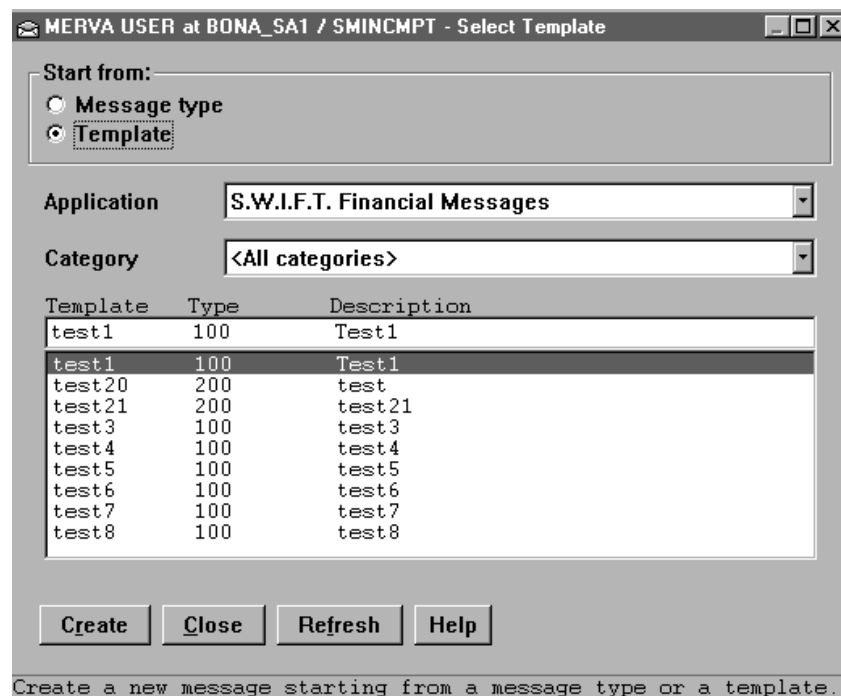

Figure 24. The Select Message Type Window with Template Selected as Message Type

The Select Template window is divided into different parts:

The **Application** list shows the message applications available to you. The contents of this field depend on the existing templates. For example, you might choose:

- S.W.I.F.T. Financial Messages in categories 1 to 9, as defined in the *S.W.I.F.T. User Handbook*
- S.W.I.F.T. System Messages in the categories GPA System Messages and FIN System Messages, as defined in the *S.W.I.F.T. User Handbook*

The **Category** list shows you the name and description of the message categories that are contained in the selected application. Each category contains different message types, for example, S.W.I.F.T. category 1 contains the message types 100 to 199. The default setting **<All categories>** allows you to enter a template identifier with a type in the entry field of the type list. The template can belong to any category of the selected application.

The lists **Template**, **Type**, and **Description** show you the template name, message type of the template, and template description of the templates that you are allowed to access.

**Note:** Entries in the **Application** list, the **Category** list, and the **Type** list might be marked with the label (?). Entries with this label refer to applications, categories, or message types that are incorrect according to the current message-processing rules of the client. A reason can be, for example, that the templates stored on the MERVA Server refer to message types that do no longer exist due to the yearly S.W.I.F.T. changes.

If you use an incorrect template to create a message, or if you display or edit an incorrect template, you get message-processing errors. To avoid this, delete the incorrect templates. For a description of how to do this, refer to “Deleting Templates” on page 104.

The following action and window buttons are available:

**Create** To create a new message.

**Close** To close the Select Message Type window without creating a message.

**Refresh**

To refresh the list of templates. This button is only active when you work with templates.

**Help** To display overview information for the current window.

To create a message by using a template:

- Select **Template** in the field **Start from**.
- Select an application from the **Application** field.
- Select a category from the **Category** field.
- Specify a template in one of the following ways:
  - Enter the name of the template that you want to use as an outline for the message.
  - Select a template from the **Template** list box.
- Select **Create** to get the Create Message window with the message body of the selected template.

---

## Creating a S.W.I.F.T. Message for Telex Transmission

To create a S.W.I.F.T. message for transmission via the public telex network, select **Telex** from the **Envelopes** menu of the Create Message window. The telex envelope is then created.

To display the telex envelope, select **Show message envelopes** from the **View** menu of the Create Message window. You then get the envelope view of the message with the telex envelope. If appropriate, you also get the MERVA Link envelope.

The following figure shows you an example of a telex envelope:

The screenshot shows a window titled "MERVA USER at SA1 / SMEDIT - Edit Message (Envelopes)". The window has a menu bar with "Envelopes", "Edit", "View", and "Help". Below the menu bar is a toolbar with icons for "Cut", "Copy", "Paste", "Expand", and "Collapse". The main area is a "Telex" form titled "Sequence 1 Telex Header:". The form contains the following fields and values:

- From Address \*: ADDRESS OF SENDER'S BANK
- Sending Date: 19971006
- To ID: TESTENKXXXX
- To Address \*: STREET1
- Telex Line: 2
- Telex Number 1 \*: 9876
- Answerback 1: UVW
- Telex Number 2: 7654
- Answerback 2: XYZ

At the bottom of the form are three buttons: "Accept", "Close", and "Help".

Figure 25. The Telex Envelope

## Fields Filled Automatically

When you first create the telex envelope for a S.W.I.F.T. input message, as much information as possible is taken from the existing message to fill the telex header.

The contents of the **LT Address** field of the S.W.I.F.T. basic header are used for a search in the correspondents database to fill the **From Address** field.

The contents of the **Receiver LT** field of the S.W.I.F.T. message (BIC code) are copied to the **To ID** field of the telex header. The correspondents database is then searched for the correspondent that is specified in the **To ID** field.

If a record is found in the correspondents database, the following telex header fields are filled automatically if data is available:

- **To Address**
- **Telex Line**
- **Telex Number 1**
- **Answerback 1**
- **Telex Number 2**
- **Answerback 2**

Other fields that are filled automatically are:

- **Sending Date**  
This field is filled with the current date.
- **Telex Reference**  
This field is filled with the contents of field 20 if field 20 is available in the S.W.I.F.T. message body.
- **Testkey Calculation Required**  
By default, this field is filled with Y.

## Telex Header Fields

The following list shows you all telex header fields for a S.W.I.F.T. message. For a more detailed description of telex header fields refer to “Viewing Telex Header Information” on page 93.

### From Address

This field contains the sender’s address in up to four lines of 35 characters each.

### Sending Date

This field contains the current date in the form of YYYYMMDD.

**To ID** This field contains the identifier of the correspondent of up to 11 characters long.

### To Address

This field contains the receiver’s address in up to four lines of 35 characters each.

### Telex Line

This field contains the telex line on which the telex message is sent. The line numbers available depend on your installation.

### Telex Reference

This field contains the telex reference identifier of up to 16 characters.

### Telex Number 1

This field contains the dial-up number of up to 20 characters long.

### Answerback 1

This field contains the expected answerback in up to 20 characters.

For a detailed description of answerback checking refer to the *MERVA USE & Branch for Windows NT Application Programming Guide*.

### Telex Number 2

This field contains an alternative dial-up number that is used if the number specified in the **Telex Number 1** field cannot be reached. The format and meaning of **Telex Number 2** are identical to those of **Telex Number 1**.

### Answerback 2

This field contains the expected answerback for the alternative dial-up number.

### Priority

This field indicates the priority of the message. The following priorities are available:

- N Normal priority
- U Urgent priority
- T Timed telex that means delayed transmission via telex link.



If you enter **T**, you must enter the earliest possible transmission time in the **Time** field. Note that you can also specify a date.

**Timed Telex Send Time**

This field indicates the time for the telex transmission of the timed telex.

You must specify the transmission time in the form of **HHMM** where **HH** stands for hours (00 to 23) and **MM** stands for minutes (00 to 59).

**Timed Telex Send Date**

This field indicates the date for the telex transmission of the timed telex.

You must specify the transmission date in the form of **YYYYMMDD** where **YYYY** stands for the year, **MM** stands for the month (01 to 12), and **DD** stands for the day (01 to 31).

**Comment**

This field contains a comment of up to 64 characters for the attention of the receiver.

## Telex Testkey Fields

**Testkey Calculation Required**

This field indicates whether a testkey calculation has to be performed for this message. By default, the field is filled with a value that is specified with the customization of the MERVVA server to which the client is connected. If the server does not deliver this value, the field is filled with **Y**. If you do not want to calculate a testkey, overwrite **Y** with **N**.

**Testkey Flag**

The value for this field is one of the following characters:

- N** The testkey calculation is not yet performed or failed.
- C** The testkey is calculated by a testkey processing program.
- V** The testkey is verified by a testkey processing program.
- G** The testkey is verified but the sequence number is out of sequence and therefore wrong.
- M** The testkey is manually calculated or verified.

**Calculation Comment**

In this field you can enter a comment that explains the calculation testkey.

After you complete the telex header, you can select one of the following:

**Accept**

To check the telex header for completeness.

The following fields must be filled:

- The first line of the **From Address** field
- The first line of the **To Address** field
- The **Telex Number 1** field
- The **Priority** field

If the priority of the message is **T**, the **Time Telex Send Time** field must also be filled.

- The **Testkey Calculation Required** field

**Save**

To save the telex envelope without checking that the mandatory fields are complete.

Use this option in case you cannot complete the telex header. The complete message can then only be saved as incomplete.

**Check** To check the telex envelope.

**Close** To close the telex envelope without saving any entries or changes.

---

## Chapter 8. Retyping Messages

During the verification process, the message is displayed on your screen. You should then check the contents by reading through the message. Some message types also contain fields that must be retyped.

This chapter explains how to verify messages by reading through the contents and retyping fields that are activated for data entry. It also shows you how to verify a telex message.

---

### Selecting a Message for Verification

You can select the messages that you want to verify in one of the following ways:

- In the Function List window specify **Retype** in the **Display only** field. This displays all message lists that you are allowed to verify. Then double-click on the list or select **Open** to get the Message List window.
- In the Function List window select **Find** to get the Specify Find Parameters dialog where you can specify search parameters.
- Select a verification function from the Function List window. Then double-click on the function or select **Open** to get the Message List window.

---

### Verifying a Message

Some message types can be verified by reading through the message. Other message types contain fields that must be retyped. To verify those messages, you must retype specific data to match the data originally entered.

After a subfield is retyped correctly, it becomes a read-only field.

The following figure shows you an example of a Retype Message window:

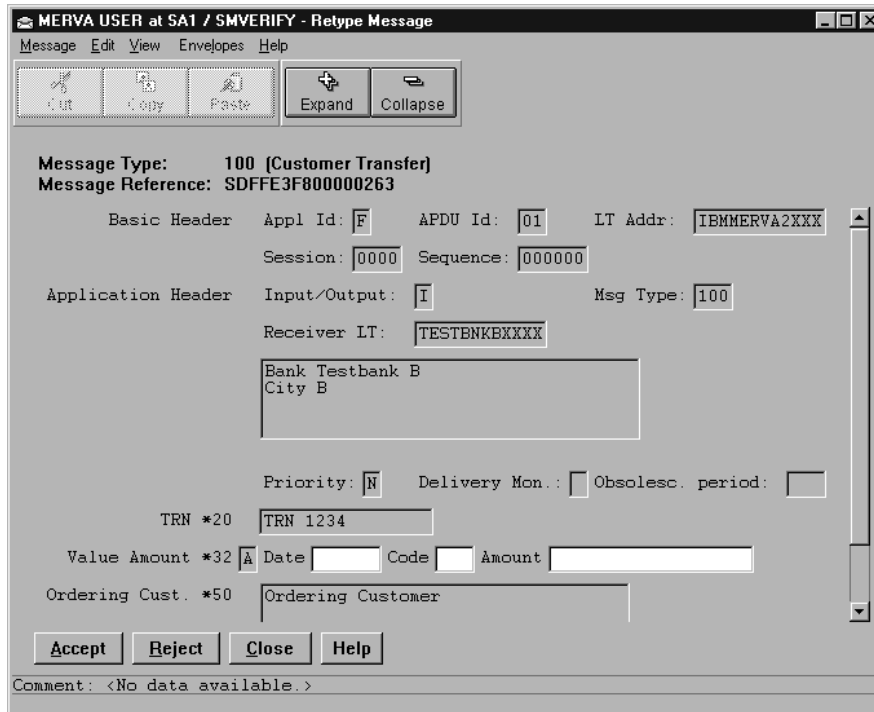

Figure 26. The Retype Message Window

When you start the Retype Message window, you see only those fields that contain data or that have to be retyped. If you want to see all fields, select **Display only fields with data** from the **View** menu.

A message is not marked as correct until you retype all fields that are marked for retype verification. You can make three attempts at retyping the contents of each field as it was originally entered. After the third unsuccessful attempt, the message is marked as incorrect and routed according to your routing conditions, usually to edit.

If the retyped information is correct, accept the message to route it to the next message-processing function. If you do not have the correct information, reject the message. It is then routed to the next message-processing function. You can add a comment in the comment field of the MERVA-related data. You can also leave the comment field unchanged. The comment field is displayed automatically. The comment might help the user who subsequently handles the message to correct the error.

The information area shows you the following:

- Comment
  - If no comment is available, you see the text **Comment: <No data available.>**
  - If a comment is available, you see the first part of the comment.
- Acknowledgment information
  - If this information is available, you see the first part of the message acknowledgment field for S.W.I.F.T. messages.
- General information
  - Shows you information about the selected menu item or the choice that the cursor is on.

You can see the complete information in the MERVA-Related Data window. For details refer to “MERVA-Related Data” on page 42.

## Working with Menu Items

The menu bar of the Retype Message window contains the following entries:

- Message
- Edit
- View
- Envelopes
- Help

### Message

The options that you can select from the **Message** menu depend on the settings for:

- MERVA functions
- User rights

For a detailed description of all options available refer to “Actions for Message Processing” on page 48.

### Edit

You can select the following options from the **Edit** menu:

- Cut** To move marked data to the clipboard.
- Copy** To copy marked data to the clipboard.
- Paste** To place data that you have cut or copied.

### View

You can select the following options from the **View** menu:

#### Show MERVA-related data

To display the MERVA-Related Data window with information that is assigned to the message by MERVA.

#### Show message envelopes

To display the Message Envelope window that contains message envelopes assigned to the message body.

The following message envelopes are valid:

- Telex  
If the message is to be sent via the telex network or is received with a telex envelope.
- MERVA Link  
Assigned by MERVA if the message is received via MERVA Link.

#### Display only fields with data

To display only fields that contain data. Empty fields are hidden. This option is selected by default.

#### Expand all sequences

To display all lower-level data for every sequence that can be expanded at one time.

#### Collapse all sequences

To hide all lower-level data for every sequence that is expanded.

## Envelopes

You cannot select any options from the **Envelopes** menu.

## Help

You can select the following options from the **Help** menu:

### Help index

To display an alphabetical list of topics for which help information is provided.

### General help

To display overview information about the current window.

### Using help

To display information on how to use the help facility.

### Keys help

To display key assignments.

### Product information

To display copyright information about the MERVA Message Processing Client.

## Working with Action and Window Buttons

The action and window buttons of the Retype Message window allow you to perform actions that are related to the message and to the active window.

The action buttons that are shown depend on the settings for:

- MERVA functions
- User rights

For a detailed description of all options available refer to “Actions for Message Processing” on page 48.

The following window buttons are valid:

**Close** To close the Retype Message window without performing an action and return to the Message List window.

**Help** To display overview information about the current window.

---

## Verifying a Telex Message

If the message that you verify is a telex message, select **Show message envelopes** from the **View** menu to see the message envelopes.

To verify the message:

1. Check that the information in the telex header is correct.
2. Select **Close** to end displaying of the telex envelope.

You can then proceed to verify the message as described in “Verifying a Message” on page 65.

---

## Chapter 9. Authorizing Messages

A message can be authorized in one or more authorization steps before it can be sent to the S.W.I.F.T. or telex network. This is done by reading through the message to check it for errors. If the message is correct, it is sent to the respective network.

This chapter explains how to authorize messages by reading carefully through the contents. It also shows you how to authorize a telex message.

---

### Selecting a Message for Authorization

You can select the messages that you want to authorize in one of the following ways:

- In the Function List window specify **Authorize** in the **Display only** field. This displays all message lists that you are allowed to authorize. Then double-click on the list or select **Open** to get the Message List window.
- In the Function List window select **Find** to get the Specify Find Parameters dialog where you can specify search parameters.
- Select an authorization function. Then double-click on the function or select **Open** to get the Message List window.

---

### Authorizing a Message

The MERVVA system offers two authorization functions, first authorization and second authorization. If your system is customized to use two authorization functions and if the message matches the specified criteria, your message must pass through both before it can be sent.

After the first authorization, messages are usually routed to the second authorization. If your system is customized in this way, the first and the second authorization procedures are identical.

Note that the customization of your system might not allow you consecutive message-processing actions. Therefore, you might not be able to authorize a message that you previously processed.

The following figure shows you an example of an Authorize Message window for the first authorization:

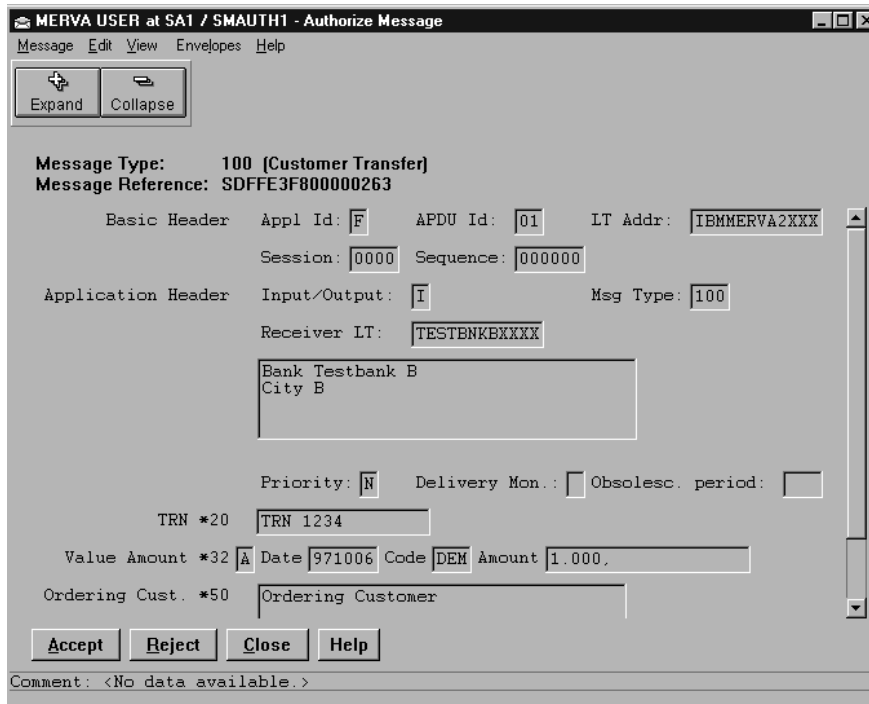

Figure 27. The Authorize Message Window

To authorize a message, read it carefully to check for errors.

If the information is correct, accept the message to route for further processing. The next processing function can be a second authorization function or a S.W.I.F.T. Link ready-to-send queue. This depends on the routing conditions of your system.

If the message is incorrect, mark it as incorrect by selecting **Reject**. It is then routed to the edit function to be corrected. Depending on the routing conditions of your system, the message might be routed to a function other than edit. You can add a comment in the comment field of the MERVA-related data. You can also leave the comment field unchanged. The comment field is displayed automatically. The comment might help the user who subsequently handles the message to correct the error.

The information area shows you the following:

- Comment
  - If no comment is available, you see the text **Comment: <No data available.>**
  - If a comment is available, you see the first part of the comment.
- Acknowledgment information
  - If this information is available, you see the first part of the message acknowledgment field for S.W.I.F.T. messages.
- General information
  - Shows you information about the selected menu item or the choice on which the cursor is.

You can see the complete information in the MERVA-Related Data window. For details refer to “MERVA-Related Data” on page 42.



## Working with Menu Items

The menu bar of the Authorize Message window contains the following entries:

- Message
- Edit
- View
- Envelopes
- Help

### Message

The options that you can select from the **Message** menu depend on the settings for:

- MERVA functions
- User rights

For a detailed description of all options available refer to “Actions for Message Processing” on page 48.

### Edit

You cannot select any options from the **Edit** menu.

### View

You can select the following options from the **View** menu:

#### Display only fields with data

To display only fields that contain data. Empty fields are hidden. This option is selected by default.

#### Expand all sequences

To display all lower-level data for every sequence that can be expanded at one time.

#### Collapse all sequences

To hide all lower-level data for every sequence that is expanded.

#### Switch to text view

To display the message body in network format.

### Envelopes

You cannot select any options from the **Envelopes** menu.

### Help

You can select the following options from the **Help** menu:

#### Help index

To display an alphabetical list of topics for which help information is provided.

#### General help

To display overview information about the current window.

#### Using help

To display information on how to use the help facility.

#### Keys help

To display key assignments.

#### Product information

To display copyright information about the MERVA Message Processing Client.

## Working with Action and Window Buttons

The action and window buttons of the Authorize Message window allow you to perform actions that are related to the message and to the active window.

The action buttons that are shown depend on the settings for:

- MERVA functions
- User rights

For a detailed description of all options available refer to “Actions for Message Processing” on page 48.

The following window buttons are valid:

**Close** To close the Authorize Message window without performing an action and return to the Message List window.

**Help** To display overview information about the current window.

---

## Authorizing a Telex Message

At any time during the authorization process, you can select **Show message envelopes** from the **View** menu to see the message envelopes.

To authorize the message:

1. Check that the information in the telex header is correct.
2. Select **Close** to end displaying of the telex envelope.

You can then proceed to authorize the message as described in “Authorizing a Message” on page 69.

---

## Chapter 10. Editing Messages

You can edit an incorrect message by checking the comment that is attached to the message if a comment exists. You then read through the message and correct any errors. After you correct and check the message, you mark the message as correct and forward it to the next-message processing function.

This chapter shows you how to complete or modify a previously created message that is not yet complete, failed verification or authorization, or was rejected by the network it was sent to, for example, NAK messages from the S.W.I.F.T. network. It also shows you how to edit a telex message.

---

### Selecting a Message for Editing

You can select the messages that you want to edit in one of the following ways:

- In the Function List window specify **Edit** in the **Display only** field. This displays all message lists that you are allowed to edit. Then double-click on the list or select **Open** to get the Message List window.
- In the Function List window select **Find** to get the Specify Find Parameters dialog where you can specify search parameters.
- Select an edit function. Then double-click on the function or select **Open** to get the Message List window.

---

### Editing a Message

In the Edit Message window you can edit a message that:

- Is not yet complete
- Failed verification
- Failed one of the authorization steps
- Is rejected by the respective network

The following figure shows you an example of an Edit Message window:

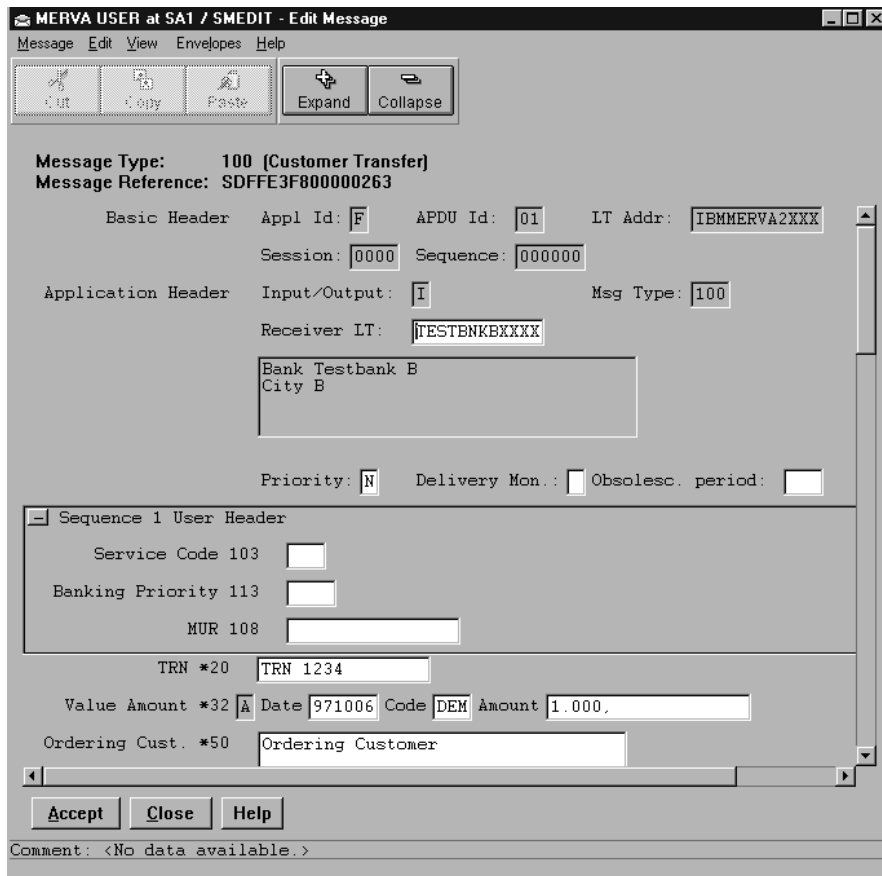

Figure 28. The Edit Message Window

To edit a message:

- Read through the message to find possible errors.
- Check the comment that is attached to the message to see possible errors or reasons for rejection.
- Use the **Check** function to display all errors. Then, read through the message and correct any errors that are indicated in the error messages.
- After you enter the data, accept the message by selecting **Accept** and route it to further message-processing functions.

Cross-field checking is then carried out. If an error is found, you get the Checking Errors window.

If you select **Close** while you edit a message, the editing process ends. The message is routed back to the edit queue without a change.

The information area shows you the following:

- Comment
  - If no comment is available, you see the text **Comment: <No data available.>**.
  - If a comment is available, you see the first part of the comment.
- Acknowledgment information
  - If this information is available, you see the first part of the message acknowledgment field for S.W.I.F.T. messages.
- General information
  - Shows you information about the selected menu item or the choice on which the cursor is.

You can see the complete information in the MERVA-Related Data window. For details refer to “MERVA-Related Data” on page 42.

## Working with Menu Items

The menu bar of the Edit Message window contains the following entries:

- Message
- Edit
- View
- Options
- Help

### Message

The options that you can select from the **Message** menu depend on the settings for:

- MERVA functions
- User rights

For a detailed description of all options available refer to “Actions for Message Processing” on page 48.

### Edit

You can select the following options from the **Edit** menu:

**Cut** To move marked data to the clipboard.

**Copy** To copy marked data to the clipboard.

**Paste** To place data that you have cut or copied.

#### Delete data from message

To delete a specific subfield or a complete segment of data.

A secondary window shows you the choice for deletion that depends on the position of the cursor. For example, if the cursor is positioned in a subfield of an occurrence of a repeatable sequence, you can delete the following data:

- Current subfield
- Field
- Data area
- Occurrence
- Complete repeatable sequence

#### Insert an occurrence

To insert one occurrence of a repeatable sequence.

A secondary window shows you occurrences of repeatable sequences that you can insert as an empty occurrence.

### View

You can select the following options from the **View** menu:

#### Show MERVA-related data

To display the MERVA-Related Data window with information that is assigned to the message by MERVA.

#### Show message envelopes

To display the Message Envelope window that contains message envelopes assigned to the message body. The following message envelopes are valid:

- Telex  
If the message is to be sent via the telex network or is received with a telex envelope.
- MERVA Link  
Assigned by MERVA if the message is received via MERVA Link.

**Display only fields with data**

To display only fields that contain data. Empty fields are hidden. This option is selected by default.

**Expand all sequences**

To display all lower-level data for every sequence that can be expanded at one time.

**Collapse all sequences**

To hide all lower-level data for every sequence that is expanded.

**Switch to text view**

To display the message body in network format.

**Envelopes**

You can select the following option from the **Envelopes** menu:

**Telex** To send a message as a telex.

When you select this option, MERVA assigns a telex envelope to the message. You can only select this option if your user profile has the authorization to create a telex. You can only deselect this option if your user profile has the authorization to remove a telex envelope. When you deselect this option, the telex envelope is removed from the message.

**Help**

You can select the following options from the **Help** menu:

**Help index**

To display an alphabetical list of topics for which help information is provided.

**General help**

To display overview information about the current window.

**Using help**

To display information on how to use the help facility.

**Keys help**

To display key assignments.

**Product information**

To display copyright information about the MERVA Message Processing Client.

**Working with Action and Window Buttons**

The action and window buttons of the Edit Message window allow you to perform actions that are related to the message and to the active window.

The action buttons that are shown depend on the settings for:

- MERVA functions
- User rights

For a detailed description of all options available refer to “Actions for Message Processing” on page 48.

The following window buttons are valid:

**Close** To close the Edit Message window without performing an action and return to the Message List window.

**Help** To display overview information about the current window.

---

## Editing a Telex Message

At any time during the edit process, you can create a telex envelope or remove an existing one depending on the settings for MERV functions and user rights. To create a telex envelope, select **Telex** from the **Envelopes** menu. To remove a telex envelope, deselect **Telex** from the **Envelopes** menu. For a detailed description of the fields of the telex headers, refer to “Creating a S.W.I.F.T. Message for Telex Transmission” on page 60.

To display the contents of a telex envelope, select **Show message envelopes** from the **View** menu. You then see the message envelopes.

To end processing or displaying of the telex envelope, select one of the following:

- **Accept**  
To check and store the telex envelope.
- **Save**  
To save the telex envelope without checking.
- **Check**  
To check the telex envelope.
- **Close**  
To close the telex envelope without changes.

You can then proceed to edit the message as described in “Editing a Message” on page 73.





---

## Chapter 11. Displaying Messages

To display messages means to view a message in a read-only mode. You can also display message envelopes and the data that MERVA assigns to the message.

---

### Selecting a Message for Displaying

You can select the message that you want to display in one of the following ways:

- In the Function List window specify **Display** in the **Display only** field. This shows you all message lists that you are allowed to display. Then double-click on the list or select **Open** to get the Message List window.
- In the Function List window select **Find** to get the Specify Find Parameters dialog where you can specify search parameters.
- Select a display function. Then double-click on the function or select **Open** to get the Message List window.

---

### Displaying a Message

In the Display Message window you can only view a message. You cannot change the message text or accept the message.

The following figure shows you an example of a Display Message window:

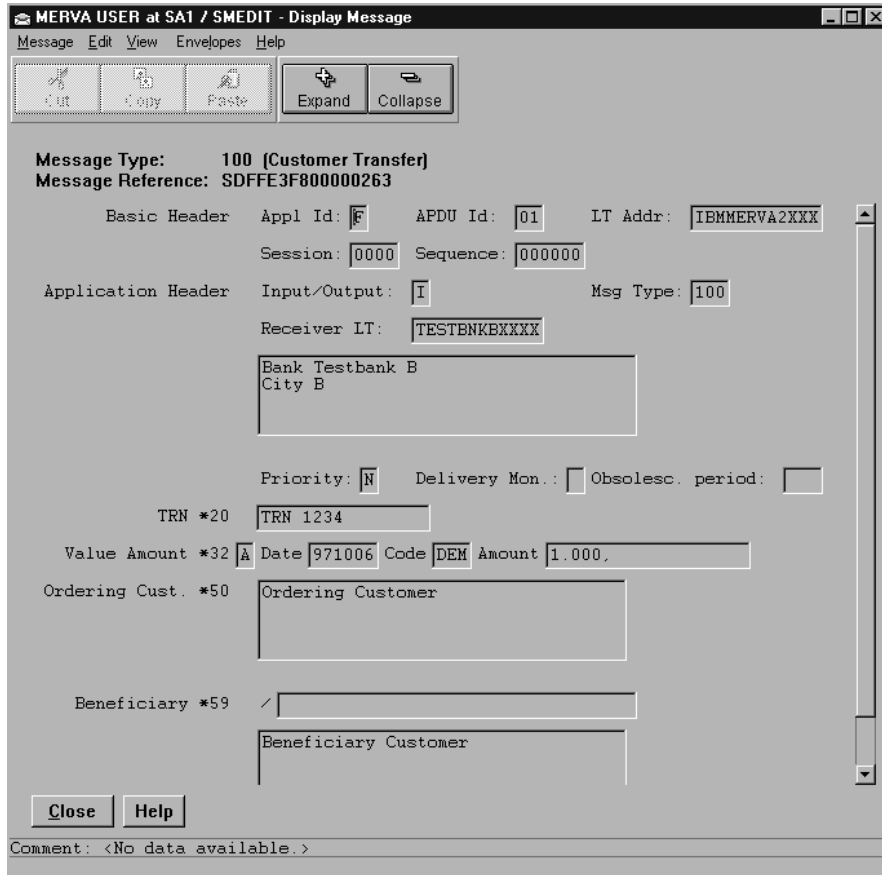

Figure 29. The Display Message Window

The information area shows you the following:

- Comment
  - If no comment is available, you see the text **Comment: <No data available.>**.
  - If a comment is available, you see the first part of the comment.
- Acknowledgment information
  - If this information is available, you see the first part of the message acknowledgment field for S.W.I.F.T. messages.
- General information
  - Shows you information about the selected menu item or the choice on which the cursor is.

You can see the complete information in the MERVA-Related Data window. For details refer to “MERVA-Related Data” on page 42.

## Working with Menu Items

The menu bar of the Display Message window contains the following entries:

- Message
- Edit
- View
- Envelopes
- Help

## Message

The options that you can select from the **Message** menu depend on the settings for:

- MERVA functions
- User rights

For a detailed description of all options available refer to “Actions for Message Processing” on page 48.

## Edit

As the text is read-only data, you cannot select all options from the **Edit** menu. The following options are available:

**Copy** To copy marked data to the clipboard.

## View

You can select the following options from the **View** menu:

### Show MERVA-related data

To display the MERVA-Related Data window with information that is assigned to the message by MERVA.

### Show message envelopes

To display the Message Envelope window that contains message envelopes assigned to the message body. The following message envelopes are valid:

- Telex  
If the message is to be sent via the telex network or is received with a telex envelope.
- MERVA Link  
Assigned by MERVA if the message is received via MERVA Link.

### Display only fields with data

To display only fields that contain data. Empty fields are hidden. This option is selected by default.

### Expand all sequences

To display all lower-level data for every sequence that can be expanded at one time.

### Collapse all sequences

To hide all lower-level data for every sequence that is expanded.

### Switch to text view

To display the message body in network format.

## Envelopes

You cannot select any options from the **Envelopes** menu.

## Help

You can select the following options from the **Help** menu:

### Help index

To display an alphabetical list of topics for which help information is provided.

### General help

To display overview information about the current window.

### Using help

To display information on how to use the help facility.

**Keys help**

To display key assignments.

**Product information**

To display copyright information about the MERVA Message Processing Client.

## Working with Window Buttons

The window buttons of the Display Message window allow you to perform actions that are related to the active window. Note that there are no action buttons for this window.

The following window buttons are valid:

**Close** To close the Display Message window without performing an action and return to the Message List window.

**Help** To display overview information about the current window.

---

## Chapter 12. Printing Messages

You can print a message in different ways. You can send a copy of the message to the print queue. The automatic print process of the MERVA Server then prints a copy of the message. After printing, the print flag that is associated with the copy of the message by MERVA is changed to **Y**.

You can also print a *working copy* of the message. The MERVA Message Processing Client then changes the print flag of the printed message immediately. This feature is additional to the printing facilities that are offered by the MERVA servers.

Note that the print flag is available only for MERVA Workstation.

---

### Selecting a Message for Printing

The MERVA Message Processing Client allows you to select the message that you want to print in one of the following ways:

- In the Message List window select the message that you want to print, then select **Copy to print**.

The message is copied to the print queue. The print flag is changed when the message is printed.

- In the Message List window select **Copy to print** from the **Selected** menu or from the pop-up menu.

The message is copied to the print queue. The print flag is changed when the message is printed.

- From a message-processing window, select **Copy to print** from the **Message** menu.

The message is copied to the print queue. The print flag is changed when the message is printed.

- Print a working copy from a message window by selecting **Print** from the **Message** menu of a message-processing window.

A *working copy* of the message is printed. After printing, the print flag is changed.

---

### Printing a Message by Using Copy to Print

Each of the described methods of selecting a message causes the Select Print Queue window to be displayed. The window looks like the following:

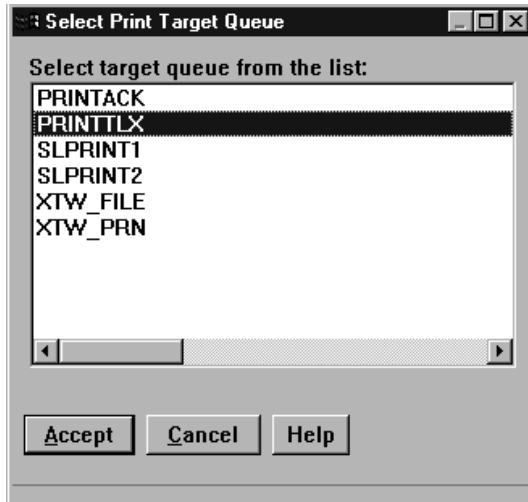

Figure 30. The Select Print Queue Window

To print a message or a list of messages:

- Select a print queue from the list.
- Select **Accept**.

Select **Cancel** to close the Select Print Queue window without printing the message.

Select **Help** to get overview information for the current window.

## Printing a Working Copy of a Message

You can also print a working copy of a message by selecting **Print** from the **Message** menu of a message-processing window. Depending on your printer settings, you can route the working copy directly to a printer or store it in a file. For information about the print options refer to “Changing Settings” on page 10.

The following figure shows you an example of a working copy of a message.

```

Page 1 of 1
-----
| M E R V A   W o r k i n g   C o p y |
-----
Message already printed: No
Msg Reference: SDFR2H237000007, Queue: SMINCLPT, 97-05-07-14.23.55.000123
Msg Type: 100 (Customer Transfer)
-----
Basic Header  Appl Id: F      APDU Id: 01  LT Addr: IBHMERVXXXX
Session: 0000  Sequence: 000000
Application Header  Input/Output: I      Msg Type: 100
Receiver LT:  IBHMERV62XXX
IBH
Boeblingen
Priority: N      Delivery Mon.:  Obsollesc. period:
TRN #20
12345
Value Amount #32 A Date 970507 Code DEH Amount 1.000,
Ordering Cust. #50 Mr. Luckmann
Beneficiary #59 /
Mr. Customer
-----> End of Message <-----

```

Figure 31. An Example of a Working Copy of a Message

---

## Chapter 13. Processing Telex and Free Format Messages

The MERV Message Processing Client allows you to work with telexes and free format messages in different ways. You can, for example, create telexes or telex envelopes, use the dispatch function, or display telex information. You can also create a free format message. Each of these options is described in detail in this chapter.

---

### Creating Telexes

With the MERV Message Processing Client, you can create telexes. Telexes belong to the message application *General*. For more information on message applications refer to “Message Groups” on page 4.

When you select **Create** in the Message List window, the Select Message Type window is the first window that is displayed to you. (For a detailed description on the Message List window refer to “Chapter 5. The Message List Window” on page 27.) The Select Message Type window shows you in hierarchical order all message types that you are allowed to create. It also shows you all template types that you are allowed to use. The following figure shows you what this window looks like if you want to create a telex:

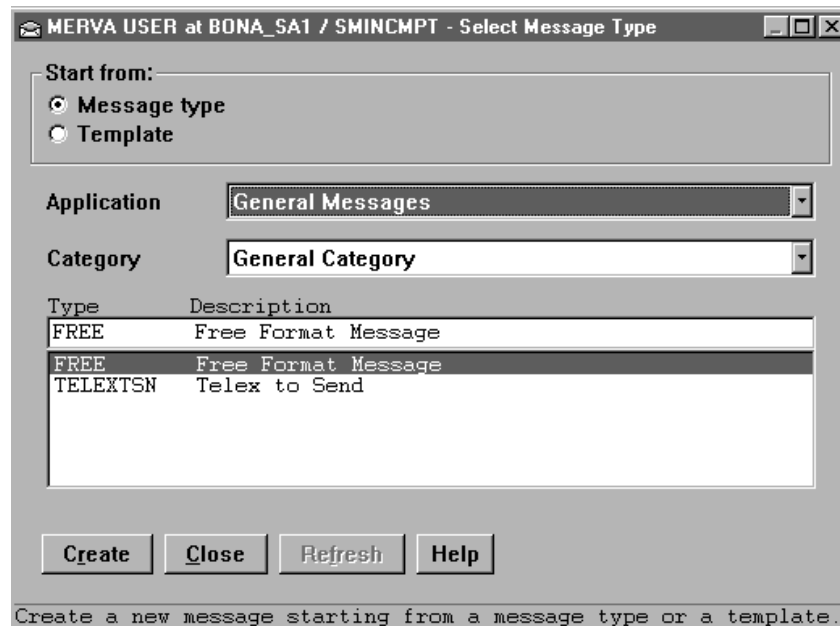

Figure 32. The Select Message Type Window for Telex Creation

To create a telex:

- Select **Message type** in the field **Start from**. This is the default selection.
- Select **General** from the **Application** field.
- Select **General** from the **Category** field.
- Specify a message type in one of the following ways:
  - Enter **TELEXTSN** as message type.

- Select **TELEXTSN** as message type from the **Type** list box.

A telex envelope is created by default. You must fill in this envelope before you can send the telex.

The line length can be up to 69 characters. You must use the telex character set.

---

## Creating a Telex Envelope

To create a telex envelope for transmission of a message via the public telex network, select **Telex** from the **Envelopes** menu of the appropriate message-processing window. The telex envelope is then created.

To display the telex envelope, select **Show message envelopes** from the **View** menu of the message-processing window. You then get the envelope view of the message with the telex envelope. If appropriate, you also get the MERVA Link envelope.

The following figure shows you an example of a telex envelope:

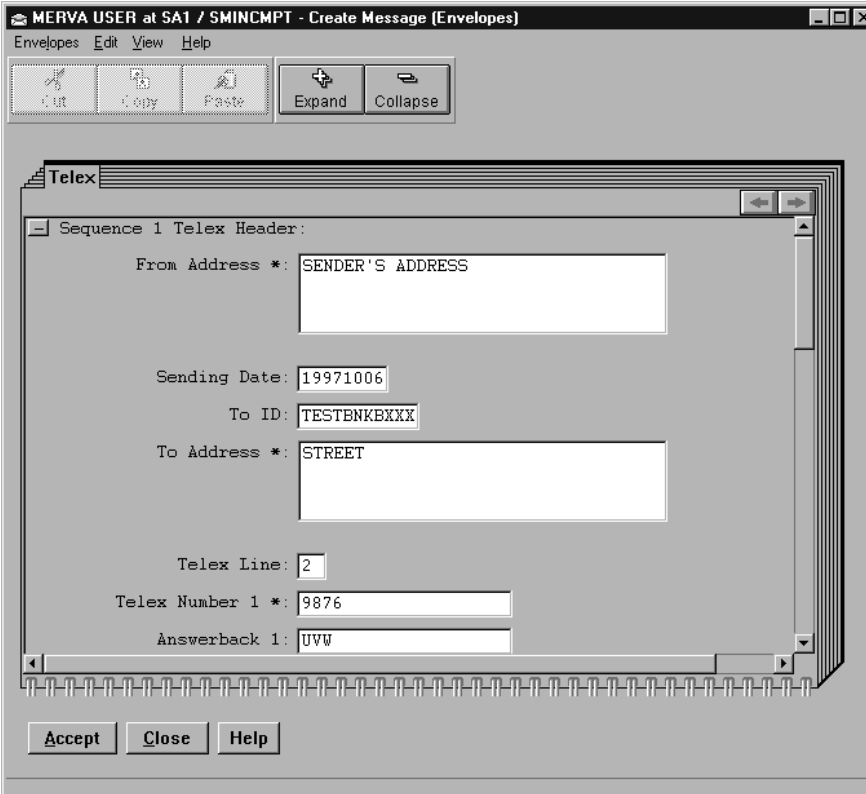

The screenshot shows a window titled "MERVA USER at SA1 / SMINCMT - Create Message (Envelopes)". The window has a menu bar with "Envelopes", "Edit", "View", and "Help". Below the menu bar is a toolbar with icons for "Cut", "Copy", "Paste", "Expand", and "Collapse". The main area of the window is titled "Telex" and contains a form for creating a telex envelope. The form has the following fields:

- From Address \*: SENDER'S ADDRESS
- Sending Date: 19971006
- To ID: TESTBNKBXXX
- To Address \*: STREET
- Telex Line: 2
- Telex Number 1 \*: 9876
- Answerback 1: UVW

At the bottom of the form are three buttons: "Accept", "Close", and "Help".

Figure 33. The Telex Envelope

The telex information that you must enter in a telex envelope consists of several parts:

- Telex header
- Telex testkey

For general telexes, these parts are described in the following sections. For S.W.I.F.T. messages, refer to "Creating a S.W.I.F.T. Message for Telex Transmission" on page 60.



## Creating the Telex Header

Depending on your message type and the contents of the correspondents database for S.W.I.F.T. messages, some of the telex header fields are filled automatically. For a detailed description of all telex header fields refer to “Viewing Telex Header Information” on page 93.

After you complete the telex header, you can select one of the following options. Note that these options are available from the **Message** menu. Some of the options are also available from the push buttons.

### Accept

To check the telex header for completeness and save it.

The following fields must be filled:

- The first line of the **From Address** field
- The first line of the **To Address** field
- The **Telex Number 1** field
- The **Priority** field

If the priority of the message is **T**, the **Timed Telex Send Time** field must also be filled.

**Save** To save the telex envelope without checking that the mandatory fields are complete.

Use this option if you cannot complete the telex header. The message is then saved as incomplete.

**Check** To check the telex envelope.

**Close** To close the telex envelope without saving any entries or changes.

## Creating the Testkey Fields

The telex testkey information can be used for testkey checking between correspondents. The following telex testkeys are available:

- **Testkey Calculation Required**
- **Testkey Flag**
- **Testkey**
- **Calculation Comment**

**Note:** The field **Testkey Calculation Required** must be filled.

For a detailed description of all testkey fields, refer to “Viewing Telex Testkey Information” on page 94.

---

## Working with the Dispatch Function

The MERVA Message Processing Client offers you a dispatch function that helps you work with telex messages.

Depending on the rights that are assigned to the queue on which you currently work, the following options are available:

### Calculate Testkey

To enter a testkey for an outgoing telex message.

### Route NAKed Telexes

To correct the telex address information of a negatively acknowledged telex message (NAKed telex message) that must be retransmitted.

### Route to Telex

To send messages to the public telex network that are in a ready-to-send queue for the S.W.I.F.T. network.

### Verify Testkey

To verify a testkey that is attached to an incoming telex message and to append the result to the message. The message is then routed accordingly.

These functions can be selected from the appropriate message-processing window menus. The functions are described in detail in the following sections.

## Calculating Testkeys

Use calculating testkeys to insert a testkey with a short comment into a message.

In the supplied standard routing, verified and authorized telex messages that contain the value **Y** in the **Testkey Calculation Required** field of the telex header are routed to a testkey calculation queue. The telex messages are then processed by this function.

After you select a message, the message body of the selected message is shown in dispatch mode. The following figure shows you an example of a message in dispatch mode:

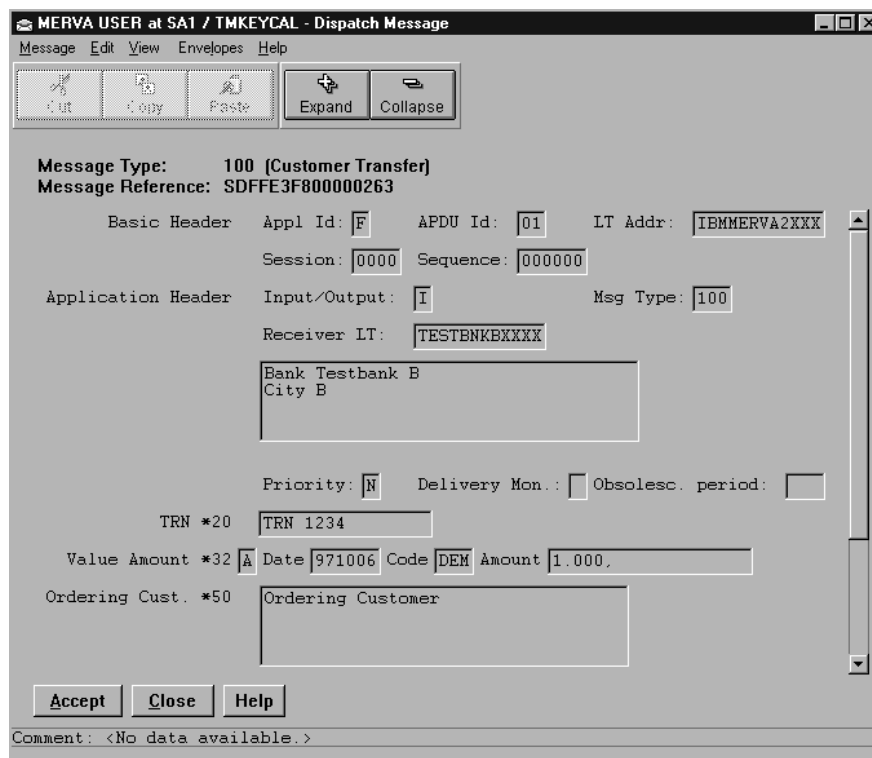

Figure 34. Example of a Message Body in Dispatch Mode for the Calculate Testkey Function

To display the contents of the telex envelope, select **Show message envelopes** from the **View** menu. You then see the message envelopes.

You can select, deselect, and change the following telex testkey fields:

**Testkey**

To enter a testkey of up to 16 characters.

**Testkey Flag**

The value for this field is one of the following characters:

- N The testkey calculation is not yet performed or failed.
- C The testkey is calculated by a testkey processing program.
- V The testkey is verified by a testkey processing program.
- G The testkey is verified but the sequence number is out of sequence and therefore wrong.
- M The testkey is manually calculated or verified.

**Calculation Comment**

To enter a comment of up to two lines of 35 characters each.

To end processing or displaying of the telex envelope, select one of the following options. Note that these options are available from the **Envelopes** menu. Some of the options are also available from the push buttons.

- **Accept**  
To check and store the telex envelope.
- **Check**  
To check the telex envelope.
- **Save**  
To save the telex envelope without checking.
- **Close**  
To close the telex envelope without changes.

To end processing or displaying of the message, select one of the following options. Note that these options are available from the **Message** menu. Some of the options are also available from the push buttons.

- **Accept**  
To check, store, and route the message according to your routing conditions.
- **Route to edit**  
To route the message to the edit queue.
- **Close**  
To close the message without changes.

## Routing Negatively Acknowledged Telex Messages

For different reasons, it might not be possible to send a message via the telex network. Those messages are called *negatively acknowledged (NAKed)*. They are routed to an appropriate message queue.

In this queue, you can proceed with the message as follows:

- Check
- Delete
- Route to a queue for retransmission
- Route to a queue for correction and retransmission

The telex information that is contained in a NAKed telex is the same as for a transmitted telex. For a detailed description of the telex information parts, refer to the corresponding section in “Viewing Telex Information in Telex Envelopes” on page 93.

Use the route NAK telexes function to process NAKed messages. With the Route NAKed telexes function, you can analyze why a message was not sent. You can also correct possible errors that are found in the telex header. The message is then routed to a telex queue from which it is later sent to the telex network.

You can determine the reason for the negative acknowledgment from one of the following:

- **Box Termination Code**
- **Expected Answerback**
- **Reason Code**

After you select a message, the message body of the selected message is shown in dispatch mode. The following figure shows you an example of a message in dispatch mode:

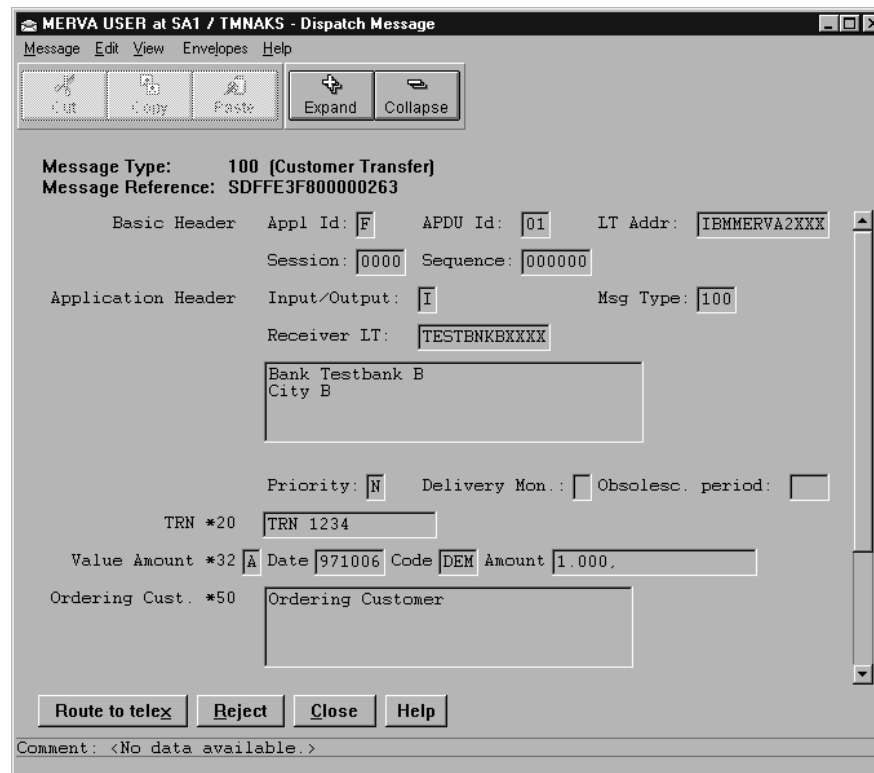

Figure 35. Example of a Message in Dispatch Mode for the Route NAKed Telex Messages Function

To display the contents of the telex envelope, select **Show message envelopes** from the **View** menu. You then see the message envelopes.

You can select, deselect, and change the telex header fields. You can also check the telex header fields by selecting **Check** from the **Envelopes** menu.

To end processing or displaying of the telex envelope, select one of the following options. Note that these options are available from the **Envelopes** menu. Some of the options are also available from the push buttons.

- **Accept**  
To check and store the telex envelope.
- **Check**  
To check the telex envelope.
- **Close**  
To close the telex envelope without changes.

To end processing or displaying of the message, select one of the following options. Note that these options are available from the **Message** menu. Some of the options are also available from the push buttons.

- **Reject**  
To mark the message as rejected and route it to further message-processing functions.
- **Route to telex**  
To route the message to a telex queue from which it is later sent to the telex network.
- **Delete by routing**  
To delete the message by routing it to a delete queue.
- **Close**  
To close the message without changes.

## Verifying Testkeys

With this function you can verify a testkey that is attached to an incoming telex message.

After you select a message, the message body of the selected message is shown in dispatch mode.

To display the contents of the telex envelope, select **Show message envelopes** from the **View** menu. You then see the message envelopes.

You can then compare the testkey that is found in the message to your separately calculated testkey.

To end processing or displaying of the telex envelope, select one of the following options. Note that these options are available from the **Envelopes** menu. Some of the options are also available from the push buttons.

- **Check**  
To check the telex envelope.
- **Close**  
To close the telex envelope without changes.

To end processing or displaying of the message, select one of the following options. Note that these options are available from the **Message** menu. Some of the options are also available from the push buttons.

- **Accept**  
To check and store the message according to your routing conditions.
- **Reject**

To mark the message as rejected and route it to further message-processing functions.

- **Close**

To close the message without changes.

## Routing Messages to the Telex Network

With this function you can send messages that are in a ready-to-send queue to the S.W.I.F.T. network to the public telex network.

After you select a message, the message body of the selected message is shown in dispatch mode.

You can handle the message in one of the following ways:

- Select **Route to telex** to route the message to a telex queue from which it is later sent to the telex network.

The telex header fields of the message are filled with values from the correspondents database.

For security reasons, you cannot change the contents of the message and the telex header. The telex header is checked for completeness, and the following fields must be filled:

- The first line of the **From Address** field
- The first line of the **To Address** field
- The **Telex Number 1** field
- If the priority of the message is **T**, the **Timed Telex Send Time** field and the **Timed Telex Send Date** field must also be filled.

If one of these fields is empty, the message cannot be routed to a telex queue. You must then select **Route to edit** to route the message to an edit queue.

- Select **Route to edit** to route the message to an edit queue for correcting the message.

You can then correct the message with the Edit Message function before you send it to another network. The message must then follow the usual message-processing steps, for example, verification and authorization, before it can be resent.

To end processing or displaying of the telex envelope, select one of the following options. Note that these options are available from the **Envelopes** menu. Some of the options are also available from the push buttons.

- **Check**

To check the telex envelope.

- **Close**

To close the telex envelope without changes.

To end processing or displaying of the message, select one of the following options. Note that these options are available from the **Message** menu. Some of the options are also available from the push buttons.

- **Route to edit**

To save the message as incomplete. This item is only enabled if a telex envelope exists.

- **Route to telex**

To check, store, and route the message according to your routing conditions.

- **Close**

To close the message without changes.

---

## Viewing Telex Information in Telex Envelopes

A telex envelope that is displayed to you contains telex information that consists of:

- Telex header
- Telex testkey information
- Telex information

These parts are described in detail in the following sections.

### Viewing Telex Header Information

The following information about telex header fields is displayed:

#### From Address

This field contains the sender's address in up to four lines of 35 characters each.

**To ID** This field contains the identifier of the correspondent of up to 11 characters long.

#### To Address

This field contains the receiver's address in up to four lines of 35 characters each.

#### Telex Line

This field contains the telex line on which the telex message is sent. The line numbers available depend on your installation.

#### Telex Number 1

This field contains the dial-up number.

Enter the telex dial-up number of the subscriber you want to call. Include the country code if required.

The dial-up number can be up to 20 characters long. It can include a digit, a slash, or a hyphen (-) to stipulate a break in dialing so that multistage dialing can be done. This is, for example, necessary in the U.S. and France where two-stage dialing is valid.

Example:  
100-xxxxxxxx

The TelexBox waits for a response after dialing 100 before proceeding with the rest of the dialing.

#### Answerback 1

This field contains the expected answerback in up to 20 characters.

Use one of the following methods for answerback checking:

- Leave the field blank to specify no answerback checking.
- Enter an asterisk to specify a check of the dial-up digits against the numeric part of the received answerback.
- Enter specific characters and digits. The default answerback checking method is used.

#### Telex Number 2

This field contains an alternative dial-up number that is used if the

number that is specified in the **Telex Number 1** field cannot be reached. The format and meaning of **Telex Number 2** are identical to those of **Telex Number 1**.

**Answerback 2**

This field contains the expected answerback for the alternative dial-up number.

**Priority**

This field indicates the priority of the message. The following priorities are available:

- N Normal priority
- U Urgent priority
- T Timed telex that means delayed transmission via telex link.

If you enter **T**, you must enter the earliest possible transmission time in the **Time** field. Note that you can also specify a date.

**Timed Telex Send Time**

This field indicates the time for the telex transmission of the timed telex.

You must specify the transmission time in the form of **HHMM** where **HH** stands for hours (00 to 23) and **MM** stands for minutes (00 to 59).

**Timed Telex Send Date**

This field indicates the date for the telex transmission of the timed telex.

You must specify the transmission date in the form of **YYYYMMDD** where **YYYY** stands for the year, **MM** stands for the month (01 to 12), and **DD** stands for the day (01 to 31).

**Telex Reference**

This field contains the telex reference identifier of up to 16 characters. If the message is a S.W.I.F.T. message and contains a transaction reference number, the information is copied into this field.

**Comment**

This field contains a comment of up to 64 characters for the attention of the receiver.

## Viewing Telex Testkey Information

The following information about telex testkeys is displayed:

**Testkey Calculation Required**

In this field you specify whether testkey calculation is required for this message. The value for this field is one of the following characters:

- Y Route to testkey calculation.  
This requires correct routing to be set up.
- N Do not route to testkey calculation.

**Testkey Flag**

The value for this field is one of the following characters:

- N The testkey calculation is not yet performed or failed.
- C The testkey is calculated by a testkey processing program.
- V The testkey is verified by a testkey processing program.



- G The testkey is verified but the sequence number is out of sequence and therefore wrong.
- M The testkey is manually calculated or verified.

**Testkey**

In this field you specify the testkey in up to 16 characters.

**Calculation Comment**

In this field you can enter a comment that explains the calculation testkey.

## Viewing General Telex Information

For MERVA Workstation, the telex information is written only by the telex provider. Therefore, the following description of the general telex information might differ from the information that is displayed to you.

Note that general telex information is displayed only for transmitted telexes. When you display the telex envelope, only fields that contain data are shown. If you edit the telex envelope, all fields are shown. The following list shows you all fields available:

**Type of Acknowledgment**

The acknowledgment type, such as positive acknowledgment or negative acknowledgment.

The data that is shown depends on your telex system. For further details refer to the corresponding documentation of your telex provider.

**Type** The telex message type.

The data that is shown depends on your telex system. For further details refer to the corresponding documentation of your telex provider.

**Report Sequence Number**

The transmission acknowledgment is the last in a series of reports for each transmitted telex. The TelexBox generates reports for every action that is associated with the telex, for example, a dial-up attempt. This sequential number indicates the number of reports that are sent for this telex message.

**Dial-up Number**

The telex number of the telex correspondent.

**Expected Answerback**

The response from the telex network.

**Transmission Start Time**

The date and time when the transmission was started.

**Transmission Duration**

The amount of time, in the form of **HHMMSS**, that is required for the transmission of the telex.

**Reason Code**

The error message code. For details on the error code refer to the corresponding documentation.

**Note:** This is not the telex transmission reason code.

**Box Used**

The number of the TelexBox that is used for transmission.

**Line Used**

The number of the telex line that is used for transmission.

**Box Termination Code**

In case of a transmission problem, this code provides a detailed explanation.

The data that is shown depends on your telex system. For further details refer to the corresponding documentation of your telex provider.

**Exceptions**

Indicates whether an error was found in the telex. For a transmitted telex, this is always zero.

**Possible Duplication**

A code that indicates that the telex was possibly sent more than once.

The data that is shown depends on your telex system. For further details refer to the corresponding documentation of your telex provider.

**Application Document Number**

The unique message identifier of the telex.

---

## Creating a Free Format Message

You can create a free format message that you do not use in the S.W.I.F.T. or telex networks.

When you select **Create** in the Message List window, the Select Message Type window is the first window that is displayed to you. (For a detailed description on the Message List window refer to “Chapter 5. The Message List Window” on page 27.)

To create a free format message:

- Select **Message type** in the field **Start from**. This is the default selection.
- Select **General** from the **Application** field.
- Select **General** from the **Category** field.
- Specify a message type in one of the following ways:
  - Enter **FREE** as message type.
  - Select **FREE** as message type from the **Type** list box.

---

## Chapter 14. Maintaining Templates

A template usually contains information that is reused on a regular basis. You use the maintain templates function to display, edit, or delete an existing template. Note that you can only use this function if the right to maintain templates is specified in your user profile.

This chapter shows you how to select, display, edit, and delete templates.

---

### Selecting a Template

If you have the right to maintain templates, the Message List window of a function for which you are allowed to create messages, shows you the action button **Templates**. Note that you see only templates that you are allowed to access. Select **Templates** to display the Maintain Templates window. The window looks like the following:

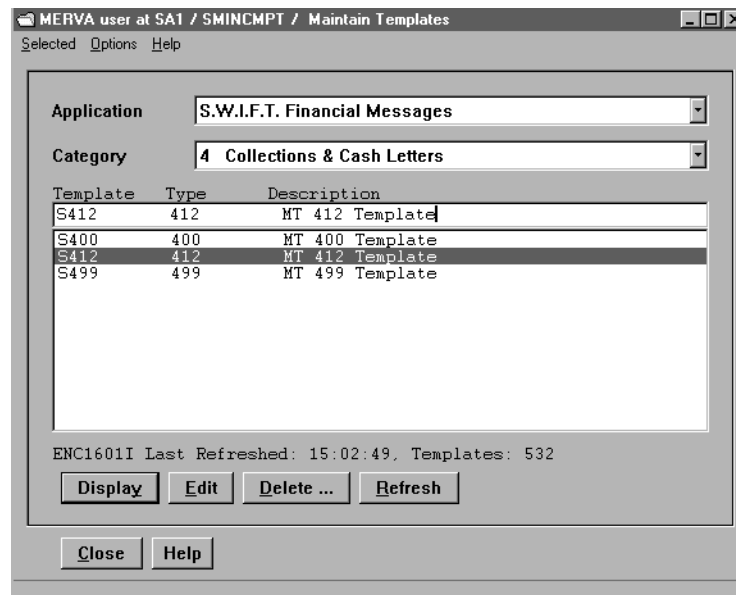

Figure 36. The Maintain Templates Window

Use the Maintain Templates window to select or specify the template you want.

The Maintain Templates window is divided into several parts:

1. Title bar with window title
2. Menu bar with menu items **Selected**, **Options**, and **Help**
3. Application list
4. Category list
5. Template, Type, and Description lists
6. Status line
7. Action buttons to perform actions related to the selected templates
8. Window buttons to perform actions related to the active window
9. Information area

With exception of the title bar, these parts are described in detail in the following sections.

The menu bar offers you menu items with pull-down menus that contain different options. Note that the options for **Selected** are identical to the action buttons **Display**, **Edit**, and **Delete**. The menu items are:

**Selected**

To display, edit, or delete the selected template.

**Options**

To update changed information within the Maintain Templates window, such as the number of templates, to its current status.

To open the Delete Templates window in which you can delete one or more templates.

**Help** To display different options for help.

The **Application** list shows the message applications available to you. You can choose between:

- S.W.I.F.T. Financial Messages in categories 1 to 9, as defined in the *S.W.I.F.T. User Handbook*
- S.W.I.F.T. System Messages in the categories GPA System Messages and FIN System Messages, as defined in the *S.W.I.F.T. User Handbook*
- General messages, such as free format message or telex message

The **Category** list shows you the name and description of the message categories that are contained in the selected application. Each category contains different message types, for example, S.W.I.F.T. category 1 contains the message types 100 to 199. The default setting **<All categories>** allows you to enter a template identifier with a type in the entry field of the type list. The template can belong to any category of the selected application.

The lists **Template**, **Type**, and **Description** show you the template name, message type of the template, and template description.

**Note:** Entries in the **Application** list, the **Category** list, and the **Type** list might be marked with the label (?). Entries with this label refer to applications, categories, or message types that are incorrect according to the current message-processing rules of the client. A reason can be, for example, that the templates stored on the MERVA Server refer to message types that do no longer exist due to the yearly S.W.I.F.T. changes.

If you use an incorrect template to create a message, or if you display or edit an incorrect template, you get message-processing errors. To avoid this, delete the incorrect templates. For a description of how to do this, refer to “Deleting Templates” on page 104.

The status line shows you information, such as:

- Information message ID to locate the message in *Messages and Codes*. To access Messages and Codes, double-click the Messages and Codes icon in the MERVA Client folder, or select it and press Enter.
- Time at which the template list is last refreshed
- Total number of templates available

The following action and window buttons are available:

### Display

To display the selected template.

### Edit

To edit the selected template.

### Delete ...

To open the Delete Templates window.

### Refresh

To update the list of templates to its current status.

### Close

To close the Maintain Templates window.

### Help

To display overview information about the current window.

---

## Displaying a Template

Displaying a template means to view the template in a read-only mode.

To display a template, select **Display** from the **Selected** menu or the action buttons in the Maintain Templates window. You then get the Display Template window that shows you the selected template. The window looks like the following:

The screenshot shows a window titled "MERYA USER at SA1 / SMINCMPT / Maintain Templates - Display Message". The window has a menu bar with "Template", "Edit", "View", "Envelopes", and "Help". Below the menu bar is a toolbar with buttons for "Cut", "Copy", "Paste", "Expand", and "Collapse". The main area displays the following information:

**Message Type: 100 (Customer Transfer)**

**Basic Header**  
Appl Id: [F] APDU Id: [01] LT Addr: [IBMMERVA2XXX]  
Session: [0000] Sequence: [000000]

**Application Header**  
Input/Output: [I] Msg Type: [100]  
Receiver LT: [TESTBNKAXXXX]  
Bank Testbank A  
City A

Priority: [N] Delivery Mon.: [ ] Obsolesc. period: [ ]

TRN \*20 [trn 1]

Value Amount \*32 [A] Date [ ] Code [USD] Amount [ ]

Ordering Cust. \*50 [Ordering Customer]

Ordering Inst. 52 [A] / [ ] / [ ]  
[TESTBNKEXXX]  
Bank Testbank B  
City B

Buttons: [Close] [Help]

Template: S100 - MT 100 Template

Figure 37. The Display Template Window

The information area shows you the following:

- Template  
You see the text **Template** succeeded by the template name and description.
- General information

Shows you information about the selected menu item or the choice on which the cursor is.

## Working with Menu Items

The menu bar of the Display Template window contains the following entries:

- Template
- Edit
- View
- Envelopes
- Help

### Template

You can select the following options from the **Template** menu:

- **Check**

When you select **Check**, the template body is searched for errors in the individual fields and in the related fields. If an error is found, you get the Checking Errors window.

- **Close**

To close the Display Template window.

### Edit

As the text is read-only data, you cannot select all options from the **Edit** menu. The following options are available:

**Copy** To copy marked data to the clipboard.

### View

You can select the following options from the **View** menu:

**Show message envelopes**

To display the Telex Envelope window if a telex envelope exists.

**Display only fields with data**

To display only fields that contain data. Empty fields are hidden. This option is selected by default.

**Expand all sequences**

To display all lower-level data for every sequence that can be expanded at one time.

**Collapse all sequences**

To hide all lower-level data for every sequence that is expanded.

**Switch to text view**

To display the template body in network format.

### Envelopes

You cannot select any options from the **Envelopes** menu.

### Help

You can select the following options from the **Help** menu:

**Help index**

To display an alphabetical list of topics for which help information is provided.

**General help**

To display overview information about the current window.

**Using help**

To display information on how to use the help facility.

**Keys help**

To display key assignments.

**Product information**

To display copyright information about the MERVA Message Processing Client.

## Working with Window Buttons

The window buttons of the Display Template window allow you to perform actions that are related to the active window. Note that there are no action buttons for this window.

The following window buttons are valid:

**Close** To close the Display Template window without performing an action and return to the Maintain Templates window.

**Help** To display overview information about the current window.

---

## Editing a Template

Use this function to complete or change a template that is not yet complete.

To edit a template, select **Edit** from the **Selected** menu or the action buttons in the Maintain Template window. You then get the Edit Template window that shows you the selected template. The window looks like the following:

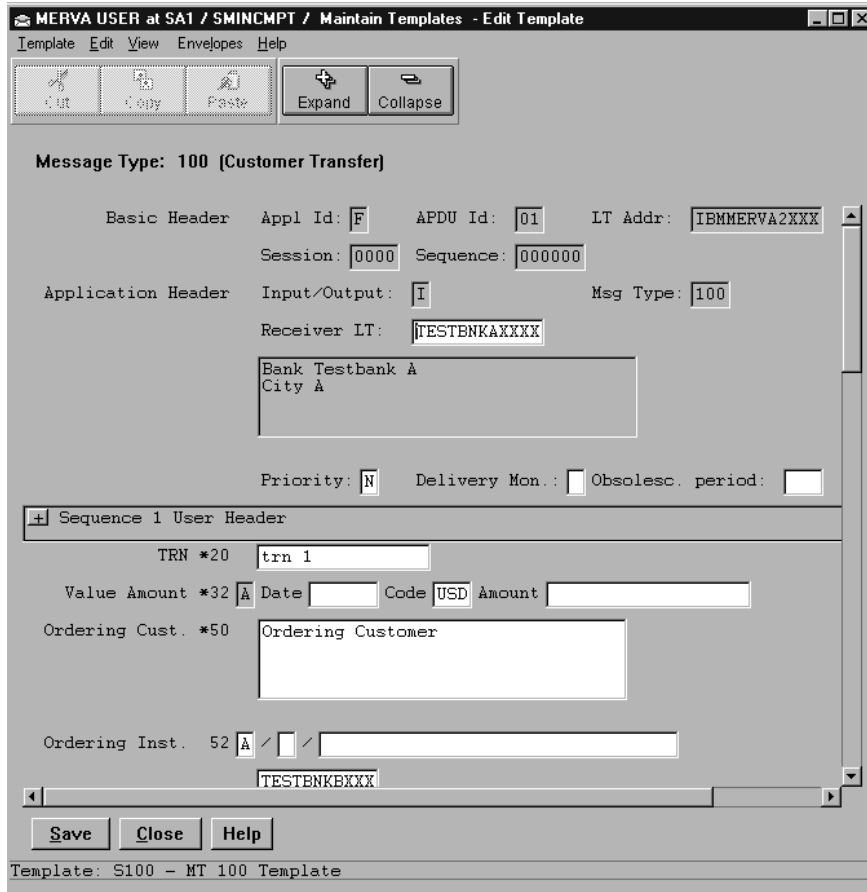

Figure 38. The Edit Template Window

The information area shows you the following:

- **Template**  
You see the text **Template** succeeded by the template name and description.
- **General information**  
Shows you information about the selected menu item or the choice on which the cursor is.

## Working with Menu Items

The menu bar of the Edit Template window contains the following entries:

- Template
- Edit
- View
- Envelopes
- Help

### Template

You can select the following options from the **Template** menu:

- **Save**  
When you select **Save**, the template is saved.
- **Check**



When you select **Check**, the template body is searched for errors in the individual fields and in the related fields. If an error is found, you get the Checking Errors window.

- **Delete**  
To delete the selected template.
- **Print**  
To print the selected template.
- **Close**  
To close the Display Template window.

## **Edit**

You can select the following options from the **Edit** menu:

- Cut** To move marked data to the clipboard.
- Copy** To copy marked data to the clipboard.
- Paste** To place data that you have cut or copied.

### **Delete data from message**

To delete a specific subfield or a complete segment of data.

A secondary window shows you the choice for deletion that depends on the position of the cursor. For example, if the cursor is positioned in a subfield of an occurrence of a repeatable sequence, you can delete the following data:

- Current subfield
- Field
- Data area
- Occurrence
- Complete repeatable sequence

### **Insert an occurrence**

To insert one occurrence of a repeatable sequence.

A secondary window shows you occurrences of repeatable sequences that you can insert as an empty occurrence.

## **View**

You can select the following options from the **View** menu:

### **Show message envelopes**

To display the Telex Envelope window if a telex envelope exists.

### **Display only fields with data**

To display only fields that contain data. Empty fields are hidden.

### **Expand all sequences**

To display all lower-level data for every sequence that can be expanded at one time.

### **Collapse all sequences**

To hide all lower-level data for every sequence that is expanded.

### **Switch to text view**

To display the template body in network format.

## **Envelopes**

You cannot select any options from the **Envelopes** menu.

## Help

You can select the following options from the **Help** menu:

### Help index

To display an alphabetical list of topics for which help information is provided.

### General help

To display overview information about the current window.

### Using help

To display information on how to use the help facility.

### Keys help

To display key assignments.

### Product information

To display copyright information and version number for the MERVA Message Processing Client.

## Working with Window Buttons

The window buttons of the Edit Template window allow you to perform actions that are related to the active window. Note that there are no action buttons for this window.

The following window buttons are valid:

**Save** To save the template.

**Close** To close the Edit Template window without performing an action and return to the Maintain Templates window.

**Help** To display overview information about the current window.

---

## Deleting Templates

Use this function to delete one or more templates.

To delete one or more templates, select **Delete ...** from the **Options** menu or from the action buttons in the Maintain Templates window. You then get the Delete Templates window that shows you the contents of the current template, type, and description. The window looks like the following:

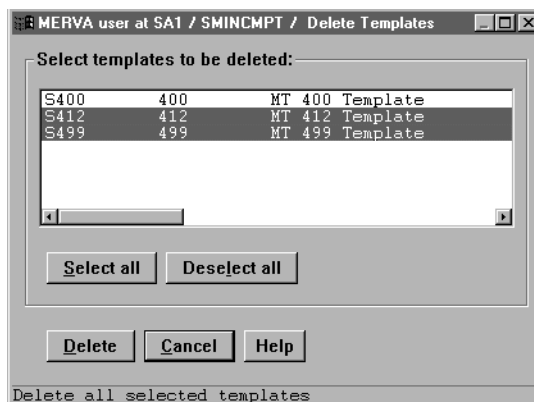

Figure 39. The Delete Templates Window

To delete a template:

1. Select the template that you want to delete.

**Note:** A template that was selected in the Maintain Templates window is selected by default in the Delete Templates window.

2. Select **Delete**.

You are requested to confirm the deletion. Only upon confirmation of the delete request is the template deleted.

To delete more than one template at the same time:

1. Select the templates that you want to delete.
2. Select **Delete**.

You are requested to confirm the deletion. Only upon confirmation of the delete request are the templates deleted.

Select **Select all** to select all templates.

Select **Deselect all** to deselect all selected templates.

Select **Cancel** to close the Delete Templates window without deleting templates.

Select **Help** to get overview information for the current window.



---

## Part 3. Appendixes



---

## Appendix A. Installation and Customization

This chapter describes how to install and customize the MERVA Message Processing Client.

---

### Installing the MERVA Message Processing Client

The following sections describe how to install the MERVA Message Processing Client.

**Note:** In this chapter the following naming conventions apply:

- The name MERVA Family Client is used when the product applies to several platforms.
- MFCL Client stands for the MERVA Family Client on the client side.
- MFCL Server stands for the MERVA Family Client on the server side.

### System Requirements

The following table lists the machine requirements needed to install the MERVA Message Processing Client.

*Table 1. Machine Requirements for the MERVA Message Processing Client*

|  |  |
|--|--|
| Processor  | Any workstation that runs under Windows/NT Version 4.0 or a subsequent release. A Pentium with 133MHz or an equivalent processor is recommended. |
| RAM  | 32MB or more.  |
| Disk space                                       | The program files require approximately 30MB of disk space.  |
| Printer (optional)                               | Any printer supported by Windows NT.   |
| Communication equipment (for remote connections) | Any interface device supported by the used communication software (for example, Token Ring Card or SDLC Adapter).                                |

The following table lists the program requirements needed to install the MERVA Message Processing Client.

*Table 2. Program Requirements for the MERVA Message Processing Client*

|                  |  |
|------------------|--|
| Operating system | Microsoft Windows NT Version 4.0 with Service Pack 4, or a subsequent release. |
|------------------|--|

Table 2. Program Requirements for the MERVA Message Processing Client (continued)

|                        |   |
|------------------------|---|
| Communication software | <p>For remote connections, the following alternatives are possible:</p> <p>For SNA APPC:</p> <ul style="list-style-type: none"> <li>• IBM eNetwork™ Personal Communication Version 4.2, Program Number 5639-B94, or a subsequent release.</li> <li>• IBM eNetwork Communications Server for Windows NT Version 6.0, Program Number 5639-F25, or a subsequent release.</li> </ul> <p>For TCP/IP</p> <ul style="list-style-type: none"> <li>• The TCP/IP support is incorporated in the Windows NT 4.0 operating system.</li> </ul> <p><b>Note:</b> The communication software might have additional program requirements depending on the interface device used.</p> |
|------------------------|---|

## General Description

During the installation procedure, the files that are necessary to work with the MERVA Message Processing Client are transferred to your workstation. At the same time, all environment changes are written to the Windows NT registry.

By default, the target destination is `C:\MERVA\Message_Processing\`. You can, however, change this destination.

In the target installation directory, the following substructure is allocated:

- **TARGET\**
- **TARGET\BIN**
- **TARGET\SAMPLES**
- **TARGET\TABLES**
- **TARGET\TRACE**

**Note:** **TARGET** is the final target installation directory.

The following list shows you the corresponding directories and their contents:

### **TARGET**

Contains the MERVA Message Processing Client customization profile **ENCTDTS.PRF** and several files that you need for corrective service and deinstallation. After installation, the environment variable **ENC\_DIR** points to this directory.

### **TARGET\BIN**

Contains the MERVA Message Processing Client application files.

### **TARGET\SAMPLES**

Contains the sample profiles. For a description of these profiles refer to “Customizing the Data Transfer Service (DTS) of the MERVA Message Processing Client” on page 116.

### **TARGET\TABLES**

Contains the MERVA message-processing tables.

### **TARGET\TRACE**

By default, this directory is empty. It can be used as target directory for trace files of the MERVA Message Processing Client.



## Installation Steps

For the installation use the setup program from diskette 1 of the MERVA Message Processing Client.

To install the MERVA Message Processing Client:

1. Insert the **MERVA ESA Components V4 CD-ROM** in the CD-ROM drive.
2. Start the setup program. To do this, open the Windows NT Explorer and double-click on the **SETUP.EXE** in the **MERVA\_Features\Message\_Processing\_Client** directory on the CD-ROM.
3. Read the displayed information carefully.
4. Follow the instructions displayed to you.
5. Select the destination location. By default, the MERVA Message Processing Client is installed in **C:\MERVA\Message\_Processing\**. To change the destination location, select **Browse**, then select a new target directory.
6. After completion, restart your system if you are advised to do so.

## Installation Verification

To ensure that the MERVA Message Processing Client is installed correctly:

1. Open the MERVA Message Processing Client folder.
2. Check whether the following program objects are shown:
  - a. MERVA Message Processing Client
  - b. Messages and Codes
3. Double-click on the MERVA Message Processing Client program object to display the MERVA Client Signon window.

When you invoke the client program for the first time, you are asked to enter the directory path where the profile of the client is to be stored. Enter an existing directory and select **Accept**.

4. Select **Help** to display the Help window.
5. In the Help window select the Esc key.
6. Select **Cancel**.

If you do not get an error message, the MERVA Message Processing Client is installed successfully.

## Corrective Service

To apply corrective service:

1. Insert the first CSD diskette in the diskette drive.
2. Start the setup program. To do this, double-click on the appropriate object in the Windows NT Explorer or enter **A:\SETUP** in the command line of an MS-DOS window.
3. Follow the instructions of the setup program to install the corrective service.
4. To generate the installation and configuration report, run the **enccfg.exe**. It is contained in the installation directory of the MERVA Client. By default, the output is sent to the screen. To sent the output to a file, use the redirect operator **>**.

---

## Customizing Message Processing for the MFCL Client

In addition to the customization described in “Changing Settings” on page 10, you can customize parts of the message processing via environment variables.

The following environment variables are valid:

- 

`ENC_AMOUNT_FORMAT = US`

Controls the format of the amount. By default, European format, for example **1.000,00**, is used. If you want to use the US format, for example **1,000.00**, set the variable value to **US**.

- 

`ENC_AUTOFILL_SWIFT_BIC = YES`

Controls the expansion of standard BIC codes. By default, a BIC code is expanded to 8 characters that do not include the branch code. If you want to expand the BIC code to 11 characters that include the branch code, set the variable value to **YES**.

- 

`ENC_AUTOFILL_SWIFT_FIELD22_ = YES`

Fills the S.W.I.F.T. fields **22** and **22C** automatically with the short S.W.I.F.T. BIC code. The short code does not include the country code. By default, you must enter the data manually. If you want the fields to be filled automatically, set the variable value to **YES**.

- 

`ENC_CHECK_SW62 = NO`

Controls the checking of the amount fields **60**, **61**, and **62**. By default, it is checked whether the amount in field **62** is equal to the amount in field **60** plus the sum of the amounts in each field **61** of the repeatable sequence. If you want to inactivate this checking, set the variable value to **NO**.

---

## Customizing Communication Systems for the MERVA Message Processing Client

The communication services of the MERVA Message Processing Client use the services of data communication subsystems (DC subsystems) to provide the partner system connectivity. You must customize these subsystems before the MERVA Message Processing Client can use them.

The customization of the DC subsystem depends on the operating system and the selected transfer protocol. Specific parameters of the DC subsystem must correspond to parameters of the DTS customization of the MERVA Message Processing Client. For detailed information refer to “Customizing the Data Transfer Service (DTS) of the MERVA Message Processing Client” on page 116. The operating systems for the MFCL Servers are Windows NT and ESA.

The communication of the MERVA Message Processing Client supports the following types of DC protocols:

- SNA APPC
- TCP/IP

For communication between an MFCL Client instance and an MFCL Server instance, the types of the DC protocol must be identical. The operating system of both instances can be different.

The following sections describe how to customize different DC subsystems for MFCL Client and MFCL Server instances on different operating systems. This description covers the DC subsystem resources that:

- Contain parameter values specifically required by MFCL Server instances.
- Are related to the DTS customization parameters of the MERVA Message Processing Client.

For more details refer to “Customizing the Data Transfer Service (DTS) of the MERVA Message Processing Client” on page 116.

General intercommunication resources are not considered.

The following table gives you an overview of the related sections in this document:

*Table 3. DC Subsystem Configurations of the MERVA Message Processing Client*

| DC Subsystem | MERVA Client  | MERVA Server   |   |
|--------------|---|--|---|
|              | NT  | ESA  | Windows NT  |
| SNA          | Refer to “SNA Customization for an MFCL Client on Windows NT”.                | Refer to “SNA Customization for an MFCL Server on ESA” on page 116.    | Refer to “SNA Customization for an MFCL Server on Windows NT” on page 114.    |
| TCP/IP       | Refer to “TCP/IP Customization for an MFCL Client on Windows NT” on page 114. | Refer to “TCP/IP Customization for an MFCL Server on ESA” on page 116. | Refer to “TCP/IP Customization for an MFCL Server on Windows NT” on page 115. |

The following sections give you an overview of the steps that are necessary to customize TCP/IP and SNA APPC. For more details refer to *MERVA Workstation Based Functions* and *MERVA Connection/NT*.

## **SNA Customization for an MFCL Client on Windows NT**

You can connect an MFCL Client instance in the Windows NT environment to an MFCL Server in the SNA environment of any supported operating system. To do this:

- You must define the compatible resources in the SNA subsystems.
- An SNA connection network must be operational to bind APPC sessions so that the server instances of the MERVA Message Processing Client can use them.

In the MFCL Client environment, customize the following basic SNA resources to establish an APPC connection to the partner system:

- LU 6.2 local LU
- LU 6.2 partner LU
- LU 6.2 mode
- SNA connection
- CPI communications side information

With respect to the MFCL Client instance, the specification of the CPI communications side information is important. It specifies the resources that are used at the server side to connect to the MFCL Server transaction program (TP):

- The symbolic destination name is used to refer to this set of CPI communications side information. This parameter corresponds to the **symp\_destination** parameter of the **enctdts.prf** DTS profile of the MERVA Message Processing Client. For details refer to “MFCL Server Node (SNODE Parameter Group)” on page 132.
- The partner LU alias or the fully qualified partner LU name identifies the APPC LU that contains the server TP.
- The partner TP name identifies the MFCL Server TP definition in the partner system. On the server side, you must specify the allocation of the real partner TP full path to the partner TP name. For details refer to “SNA Customization for an MFCL Server on ESA” on page 116, and to “SNA Customization for an MFCL Server on Windows NT”.
- The mode name parameter identifies the LU 6.2 mode profile that is used for APPC sessions between the cooperating LUs.
- The security type defines the conversation security type that is used with this transaction program. The recommended security type is **Program**.

## TCP/IP Customization for an MFCL Client on Windows NT

You do not have to customize the TCP/IP subsystem so that an MFCL Client instance can use it. You can, however, define the short name of a partner host where the MFCL Server is located in the file **%ETC%\HOSTS**. This parameter corresponds to the **partner\_host** parameter of the **enctdts.prf** profile of the MERVA Message Processing Client. For details refer to “MFCL Server Node (SNODE Parameter Group)” on page 132.

The parameter value of the partner host name can be one of the following:

- A short host name that is translated to the corresponding IP address by a TCP/IP name server or by information in the file **/etc/hosts**
- The official partner host name that includes the TCP/IP domain identifiers
- The IP address of the partner host in dotted-decimal representation

## SNA Customization for an MFCL Server on Windows NT

You can connect an MFCL Server instance in the Windows NT environment to an MFCL Client in the SNA environment of any supported operating system. To do this:

- You must define the compatible resources in the SNA subsystems.
- An SNA connection network must be operational to bind APPC sessions so that the MFCL Server instances can use them.

In the MFCL Server environment, customize the following basic SNA resources to establish an APPC connection to the partner system:

- LU 6.2 local LU
- LU 6.2 partner LU
- LU 6.2 mode
- LU 6.2 conversation security
- Transaction program definition

Regarding the MFCL Server instance, the specification of the transaction program definition is important. It defines the resources that are used to refer to the right MFCL Server transaction program TP. This program handles each request of the MFCL Client.

The path and file name of the Windows NT program must specify the Windows NT path of the receiving program **enctpi.exe** of the MFCL Server, for example:

**Complete path name**                    <mervabin>\enctpi  
**Program parameters**                [<instance> [<tracedir>[\<tracelevel>]]]

where:

- <mervabin> is the bin directory of the MERVA installation. Note that this is not the MERVA Family Client installation.
- <instance> is the name of the MERVA instance.
- <tracedir> is the trace directory of the MFCL DTS trace. You can use any parameter.
- <tracelevel> indicates the level of tracing.

## TCP/IP Customization for an MFCL Server on Windows NT

On Windows NT, you must use the MERVA inetd service for the MERVA Family Client. For information on how to install the inetd service, refer to the *MERVA USE & Branch for Windows NT Installation and Customization Guide*.

To use the MERVA inetd service daemon:

1. Add the MFCL service to the file **services**. This file is installed automatically by Windows NT. It is located in the path %**SystemRoot**%\system32\drivers\etc\. The path %**SystemRoot**% is provided by the environment variable **SystemRoot**.

To add the MFCL service, add the following line to the file **services**:

```
MFCL                    7117/tcp                    # MERVA Client DTS Server
```

**Note:** Do not add this line as the last line otherwise, the Win32 API call that searches the file cannot find it.

This defines the service MFCL for port number 7117 using TCP as protocol. You can specify the name of the service and the port number as you like. The port number, however, should be greater than 2134 because the range of the well-known ports for TCP/IP is 1 to 2134.

2. Copy the sample file **enminetd.cfg** from the samples directory of MERVA to %**SystemRoot**%\system32\drivers\etc\.

3. Add the following line to the file **enminetd.cfg**:

```
MFCL stream tcp nowait root <mervabin>\enctci<instance> [<tracedir>[\<tracelevel>]]
```

where:

- <mervabin> is the bin directory of the MERVA installation. Note that this is not the MERVA Family Client installation.
- <instance> is the name of the MERVA instance.
- <tracedir> is the trace directory of the MFCL DTS trace. You can use any parameter.
- <tracelevel> indicates the level of tracing.

This defines that the transaction program <mervabin>\enctci starts on request of the service MFCL.

The following example shows you a definition for MERVA installed on drive D:

```
MFCL stream tcp nowait root d:\MERVA\USE_Branch\bin\enctci merval d:\merva\trace\3
```

4. Start the MERVA inetd service as described in the *MERVA USE & Branch for Windows NT Installation and Customization Guide*.

## SNA Customization for an MFCL Server on ESA

You can connect an MFCL Server instance in the ESA SNA environment to an MFCL Client in the SNA environment of any supported operating system. To do this:

- You must define the compatible resources in the SNA subsystems.
- An SNA connection network must be operational to bind APPC sessions so that the MFCL Server instances can use them.

For detailed information and configuration examples, refer to *MERVA Workstation Based Functions*.

## TCP/IP Customization for an MFCL Server on ESA

You can connect an MFCL Server instance in the ESA TCP/IP environment to an MFCL Client in the TCP/IP environment of any supported operating system. To do this, you must define the compatible resources in the TCP/IP subsystems.

For details on the customization of the MERVA ESA TCP/IP services, refer to *MERVA Workstation Based Functions*.

---

## Customizing the Data Transfer Service (DTS) of the MERVA Message Processing Client

By using the DTS of the MERVA Message Processing Client, an MFCL Client and an MFCL Server can communicate. If the MFCL Client and the MFCL Server are located on the same workstation, local communication is used. For remote connections between the MFCL Client and the MFCL Server, SNA APPC or TCP/IP can be used.

The DTS of the MERVA Message Processing Client transfers each data between clients and servers as determined by the contents of its Data Transfer Service profile, abbreviated to DTS profile. The information on how to interconnect partner systems (intersystem connection parameters) is the most important information. The DTS profile is a flat file. The name of the file is **enctdts.prf**.

The DTS profile is available only for the Windows NT platform. The DTS of the MERVA ESA server has fixed DTS parameters. These parameters are also used for the MERVA ESA client.

Each MERVA Message Processing Client workstation uses one DTS profile. If a local MFCL Client is installed on an MFCL Server, the MFCL Client and the MFCL Server use the same DTS profile. The parameters in a DTS profile can be valid only for an MFCL Client environment or only for an MFCL Server environment (Windows NT). You can define parameter sets for several MFCL Client or MFCL Server nodes in one profile.

## Introduction to Node Resource Groups

The information in the MERVA Family Client DTS profile consists of a set of typed node resource groups. The following node resource groups are defined:

**LNODE**

Contains information about a local MFCL Client or MFCL Server node.

**SNODE**

Contains information about a remote MFCL Server node.

**CNODE**

Contains information about a remote MFCL Client node.

A DTS profile contains any number of any node resource group in any sequence.

An LNODE group contains information about local node and either one or more local MFCL Clients or MERVA applications. The local node can be an MFCL Client or an MFCL Server node, or both.

An SNODE group contains information about an MFCL Server node and one or more MERVA server applications. This resource group is only applicable in an MFCL Client environment.

A CNODE group contains information about an MFCL Client node and one or more client applications. This resource group is only applicable in an MFCL Server environment.

The following list shows you the complete structure of the DTS profile:

```
LNODE:
    ( local node parameters ...          )
  APPL:
    ( local application 1 parameters ... )
  APPL:
    ( local application 2 parameters ... )

SNODE:
    ( server node 1 parameters ...      )
  APPL:
    ( server 1 application 1 parameters ...)
  APPL:
    ( server 1 application 2 parameters ...)

SNODE:
    ( server node 2 parameters ...      )
  APPL:
    ( server 2 application 1 parameters ...)
  APPL:
    ( server 2 application 2 parameters ...)

CNODE:
    ( client node 1 parameters          )
  APPL:
    ( client 1 application 1 parameters ...)
  APPL:
    ( client 1 application 2 parameters ...)

CNODE:
    ( client node 2 parameters          )
  APPL:
    ( client 2 application 1 parameters ...)
  APPL:
    ( client 2 application 2 parameters ...)
```

The following sections show you basic examples with only mandatory parameters for DTS profiles. At the end of each section, you find a brief description of the mandatory parameters and possible additional parameters. For a summary of all



parameters that you can use in the **enctdts.prf**, refer to “DTS Profile Contents (MFCL Client)” on page 131 and “DTS Profile Contents (MFCL Server)” on page 135.

## Example A — Message Processing

The following figure shows you an MFCL Server that is used for local message processing. You can install this profile on a MERVA Workstation server.

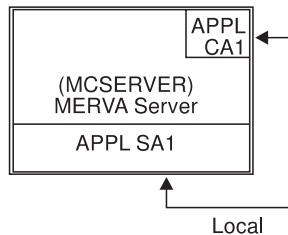

Figure 40. Message Processing with an MFCL Server

The following section shows you an example of an **enctdts.prf** profile for MERVA Workstation message processing with an integrated MERVA Client.

```

=====
# MERVA Message Processing Client (MFCL) DTS Profile
# Example for an MFCL Server with a local MFCL Client
=====

#-----
# Local Node Definitions
#-----

LNODE:
    local_node_name    = MCSERVER    Local MFCL node
                                Local MFCL node name

    APPL:
        application_name    = CA1        Local client application
                                (MFCL Server is both, client and server)

    APPL:
        application_name    = SA1        Local server application

#-----
# Server Node Definitions
#-----

SNODE:
    server_node_name    = MCSERVER    MFCL Server node (here: local server)
                                MFCL Server node name

    APPL:
        application_name    = SA1        Remote server application (here: local)
                                Server application formal name
        connection_type    = LOCAL    Connect locally to server

=====
# MERVA Message Processing Client (MFCL) DTS Profile End
=====

```

### Parameters Used in This Example

In the **LNODE** group:

#### **local\_node\_name**

Specifies the name of the local node. You can specify the name as you like.



**application\_name**

Specifies the name of the application. In the example, a client and a server application are defined on the local node. You can specify the application names as you like, but they must be unique. You can have more than two applications with different settings on a server.

In the **SNODE** group:

**server\_node\_name**

Specifies the name of the local MFCL Server. The name must match the name of the MFCL Server defined in the **LNODE** resource group.

**application\_name**

Specifies the name of the server application. The name must match the name of the server application defined in the **LNODE** resource group.

**Additional Parameters**

Additionally, you can set the following parameters:

- To activate trace files, set **dts\_trace\_dir** or **dts\_trace\_file** on the MFCL Client side.
- To specify the trace level, set **dts\_trace\_level**.
- To change the MERVA message-processing table, set **msg\_proc\_table**. The default table is **MERVASON.MRT**.

**Example B — MFCL Server with a Local and a Remote Client**

The following figure shows you the contents of “Example A — Message Processing” on page 118 but with a remote MFCL Client (Windows NT) added. An MFCL Client called **CLIENT\_A** is connected to the MFCL Server through TCP/IP. Note that the local MFCL Client on the server workstation still exists.

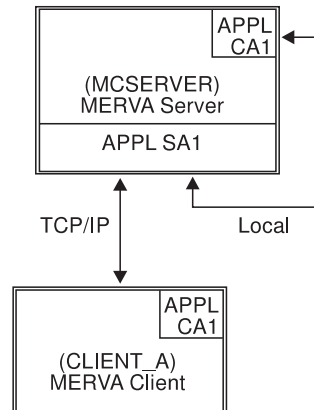

Figure 41. Message Processing with an MFCL Client/MFCL Server

**MFCL Server DTS Profile**

The following example shows you an MFCL Server DTS profile. You can use the DTS profile that is described in “Example A — Message Processing” on page 118. However, in this example, a **CNODE** resource group with the **ca\_match** parameter is added. This ensures that only MFCL Clients that are indicated in the **CNODE** resource group can connect to this server node.

```

=====
# MERVA Message Processing Client (MFCL) DTS Profile
# Example for an MFCL Server with a local and a remote client
=====

```

```

#-----
# Local Node Definitions
#-----

LNODE:
    local_node_name = MCSERVER Local MFCL node
    ca_match        = yes      Local MFCL node name
                                Check all client addresses

    APPL:
        application_name = CA1 Local client application
                                (MFCL Server is both, client and server)

    APPL:
        application_name = SA1 Local server application

#-----
# Server Node Definitions
#-----

SNODE:
    server_node_name = MCSERVER MFCL Server node (local server)
                                MFCL Server node name

    APPL:
        application_name = SA1 Server application
                                Server application formal name
        connection_type = LOCAL Connect locally to server

#-----
# Client Node Definitions
#-----

CNODE:
    client_node_name = MCSERVER MFCL Client node (here: local client)

    APPL:
        application_name = CA1 Client application
                                Client application name

CNODE:
    client_node_name = CLIENT_A MFCL Client node

    APPL:
        application_name = CA1 Client application
                                Client application name

#=====
# MERVA Message Processing Client DTS Profile End
#=====

```

### Parameters Used in This Example:

In the **LNODE** group:

#### **local\_node\_name**

Specifies the name of the MFCL node. You can specify the name as you like, but it must be unique for all interconnected MERVA Family Client nodes.

#### **ca\_match**

If this parameter is set to **Yes**, all MFCL Clients that try to connect to the MFCL Server are checked. If an MFCL Client is not defined in the **CNODE** resource group of the DTS profile, the connection attempt is rejected. By default, this parameter is set to **No**.

**application\_name**

Specifies the name of the application. In the example, a client and a server application are defined on the local node. You can specify the application names as you like, but they must be unique. You can have more than two applications with different settings on an MFCL Server.

In the **SNODE** group:

**server\_node\_name**

Specifies the name of the local MFCL Server node. The name must match the name of the MFCL Server node defined in the **LNODE** resource group on the MFCL Server.

**application\_name**

Specifies the name of the server application. This name must be unique within the **SNODE** group.

In the **CNODE** group:

**client\_node\_name**

Each MFCL Client has a unique local node name. You can specify all MFCL Clients that are allowed to connect to the MFCL Server in the **CNODE** resource group. If the parameter **ca\_match** is set to **Yes**, the server then rejects connection attempts of MFCL Clients that are not contained in the **CNODE** resource group.

**application\_name**

For each MFCL Client node in the **CNODE** resource group, one or more applications are defined. Only applications with this parameter can connect to the MFCL Server. If **CNODE** resource groups are not defined, and if the parameter **ca\_match** is set to **No**, any client application can connect to the MFCL Server.

**Additional Parameters:**

Additionally, you can set the following parameters:

- To specify encryption methods, set **encryption**.
- To specify a security key modifier, set **sec\_key\_modifier**.
- To specify a timeout value for the MFCL Client, set **sp\_timeout**.
- You can specify whether the name of the server application that is received from the MFCL Client in the connect request must be verified. To do this, set **sa\_match**.

**MFCL Client DTS Profile**

The following example shows you the corresponding MFCL Client (Windows NT) DTS profile. The MFCL Client is called **CLIENT\_A**. This corresponds to the standard profile that is provided by the installation of the MERVA Message Processing Client.

```

=====
# MERVA Message Processing Client (MFCL) DTS Profile
# Example for an MFCL Client
=====

#-----
# Local Node Definitions
#-----

LNODE:
    local_node_name = CLIENT_A Local node is an MFCL Client node
                                Local MFCL Client node name

```

```

APPL:                                     Local client application
      application_name = CA1

#-----
# Server Node Definitions
#-----

SNODE:                                     Remote MFCL Server node
      server_node_name = MCSERVER MFCL Server node name
      partner_host     = hostname  TCP/IP hostname of MFCL Server
      port_number      = 7117     Port number of the MFCL service

APPL:                                     Server application
      application_name = SA1       Server application formal name
      connection_type = TCP/IP    Connection type is TCP/IP

#-----
# MERV A Message Processing Client DTS Profile End
#-----

```

### Parameters Used in This Example:

In the **LNODE** group:

#### **local\_node\_name**

Specifies the name of the local MFCL Client. You can specify the name as you like, but it must be unique for all interconnected MERV A Message Processing Client nodes.

#### **application\_name**

Specifies the name of the application. The local node in the example has one application defined. You can specify the application name as you like, but it must be unique. You can have more than one application with different settings on an MFCL Client. Because the example describes a DTS profile for an MFCL Client, a server application is not defined.

In the **SNODE** group:

#### **server\_node\_name**

Specifies the name of the remote MFCL Server. The name must match the name of the MFCL Server defined in the **LNODE** resource group on the MFCL Server.

#### **partner\_host**

Specifies the TCP/IP host name of the MFCL Server node. It can also specify the TCP/IP address in dotted-decimal form. You must set this parameter, if TCP/IP is used.

#### **port\_number**

Specifies the port number of the **inetd** service (**enctci.exe**). The port number must match the port number that is specified in the **%ETC%\SERVICES** file on the MFCL Server. You must set this parameter, if TCP/IP is used.

#### **application\_name**

Specifies the name of the remote server application. If the **ca\_match** parameter is set to **Yes**, the MFCL Server checks the MFCL Clients for the correct name of the server application. Connection attempts with incorrect names are rejected.

### connection\_type

Specifies how the connection is established through a keyword. Valid keywords are **TCP/IP** for a TCP/IP connection, **SNA** for an APPC connection, and **LOCAL** for local message processing through the local MFCL Server.

### Additional Parameters:

Additionally, you can set the following parameters:

- To activate trace files, set **dts\_trace\_dir** or **dts\_trace\_file** on the MFCL Client side.
- To specify the trace level, set **dts\_trace\_level**. You can set the trace level separately for each MFCL Server node.
- To activate the **TCP\_NODELAY** flag, set **tcp\_nodelay**. You can set this parameter for each MFCL Server node.
- To provide information for the logon panel of each server application, set **informal\_name** for the name of the server application. You can then see the server name in the pull-down menu of the MERVA Message Processing Client logon panel. You can also set **free\_form\_name** for other additional information.
- To change the MERVA message-processing table, set **msg\_proc\_table**. The default table is **MERVASON.MRT**.
- To specify encryption methods, set **encryption**. You can set this parameter separately for each MFCL Client.
- To specify a security key modifier, set **sec\_key\_modifier**.
- To specify a timeout value for the MFCL Server, set **cp\_timeout**.
- To get a prompt window for the conversation security user ID and password of a TCP/IP connection, set **cvsec\_prompt**.

## Example C — MFCL Server with a Local and Two Remote Clients

The following figure shows you the contents of “Example B — MFCL Server with a Local and a Remote Client” on page 119 but with a second MFCL Client added. An MFCL Client called **CLIENT\_B** is connected to the MFCL Server through SNA APPC.

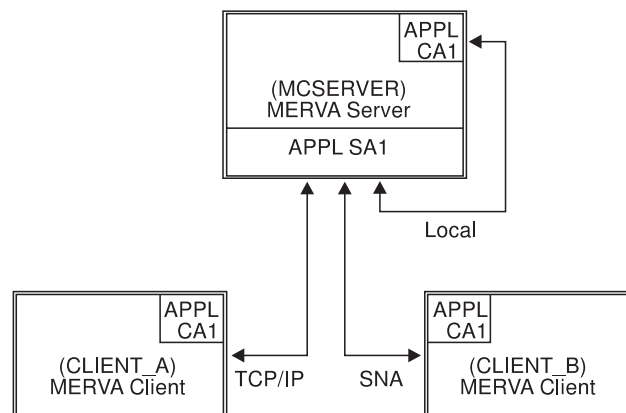

Figure 42. MFCL Client/MFCL Server

## MFCL Server DTS Profile

To add a new MFCL Client, an additional entry in the **CNODE** resource group on the MFCL Server side is necessary. If you do not use the **CNODE** resource group, and if you set the parameter **ca\_match** to **No**, you do not have to change the entries.

The following example shows you the additional entry. You can also compare this example to “Example B — MFCL Server with a Local and a Remote Client” on page 119 to see the changes.

```
#####
# MERV Message Processing Client (MFCL) DTS Profile
# Example for an MFCL Server and three MFCL Clients
#####

#-----
# Local Node Definitions for an MFCL Server and Client
#-----

LNODE:
    local_node_name = MCSERVER    Local node is an MFCL Server node
    ca_match        = yes         Local MFCL node name
                                Check all client addresses

APPL:
    application_name = CA1        Local client application
                                (MFCL Server is both, client and server)

APPL:
    application_name = SA1        Local server application

#-----
# Server Node Definitions
#-----

SNODE:
    server_node_name = MCSERVER    MFCL Server node (for local client)
                                MFCL Server node name

APPL:
    application_name = SA1        Server application
                                Server application formal name
    connection_type  = LOCAL      Connect locally to server

#-----
# Client Node Definitions
#-----

CNODE:
    client_node_name = MCSERVER    MFCL Client node (here: local client)

APPL:
    application_name = CA1        Client application
                                Client application name

CNODE:
    client_node_name = CLIENT_A    MFCL Client node

APPL:
    application_name = CA1        Client application
                                Client application name

CNODE:
    client_node_name = CLIENT_B    MFCL Client node

APPL:
    application_name = CA1        Client application
                                Client application name
```

```
#=====
# MERV Message Processing Client DTS Profile End
#=====
```

### Parameters Used in This Example:

In the **LNODE** group:

#### **local\_node\_name**

Specifies the name of the local node. You can specify the name as you like, but it must be unique for all interconnected MFCL nodes.

#### **ca\_match**

If this parameter is set, all MFCL Clients that try to connect to the MFCL Server are checked. If an MFCL Client is not defined in the **CNODE** resource group of the DTS profile, the connection attempt is rejected. By default, this parameter is set to **No**.

#### **application\_name**

Specifies the name of the application. The local node in the example has two applications defined. You can specify the application names as you like, but they must be unique. You can have more than two applications with different settings on an MFCL Server. In the example, a client and a server application are defined on the local node.

In the **SNODE** group:

#### **server\_node\_name**

Specifies the name of the local MFCL Server. The name must match the name of the MFCL Server defined in the **LNODE** resource group.

#### **application\_name**

Specifies the name of the server application. The name must be unique within the **SNODE** group.

In the **CNODE** group:

#### **client\_node\_name**

Each MFCL Client has a unique local node name. You can specify all MFCL Clients that are allowed to connect to the MFCL Server in the **CNODE** resource group. If the parameter **ca\_match** is set to **Yes**, the server then rejects connection attempts of MFCL Clients that are not contained in the **CNODE** resource group.

#### **application\_name**

For each MFCL Client node in the **CNODE** resource group, one or more applications are defined. Only applications with this parameter can connect to the MFCL Server. If no **CNODE** resource groups are defined and the parameter **ca\_match** is set to **No**, any client application can connect to the MFCL Server.

### Additional Parameters:

Additionally, you can set the following parameters:

- To specify encryption methods, set **encryption**. You can set this parameter separately for each MFCL Client.
- To specify a security key modifier, set **sec\_key\_modifier**.
- To specify a timeout value for the MFCL Client, set **sp\_timeout**.

- You can specify whether the name of the server application that is received from the MFCL Client in the connect request must be verified. To do this, set **sa\_match**.

### MFCL Client DTS Profile

The following example shows you an **enctdts.prf** profile of an MFCL Client. In the example, the MFCL Client has the local node name **Client\_B**.

```

=====
# MERVAs Message Processing Client (MFCL) DTS Profile
# Example for an MFCL Server and three MFCL Clients
=====

#-----
# Local Node Definitions
#-----

LNODE:
    local_node_name      = CLIENT_B      Local MFCL Client node name
                                     Local node is an MFCL Client node

    APPL:
        application_name = CA1           Local client application

#-----
# Remote Server Node Definitions
#-----

SNODE:
    server_node_name     = MCSERVER      MFCL Server node name
    symb_destination     = MCSERV
                                     Remote MFCL Server node

    APPL:
        application_name = SA1           Server application formal name
        connection_type  = SNA           Connection type is TCP/IP

#-----
# MERVAs Message Processing Client DTS Profile End
=====

```

### Parameters Used in This Example:

In the **LNODE** group:

#### **local\_node\_name**

Specifies the name of the local MFCL Client. You can specify the name as you like, but it must be unique for all interconnected MERVAs Family Client nodes.

#### **application\_name**

Specifies the name of the application. The local node in the example has one application defined. You can specify the application name as you like, but it must be unique. You can have more than one application with different settings on an MFCL Client. Because the example describes a DTS profile for an MFCL Client, a server application is not defined.

In the **SNODE** group:

#### **server\_node\_name**

Specifies the name of the remote MFCL Server. The name must match the name of the MFCL Server defined in the **LNODE** resource group on the MFCL Server.



**symb\_destination**

Specifies the symbolic destination name that is used in the CPI-C side information of SNA. You must set this parameter, if SNA APPC is used.

**application\_name**

Specifies the name of the remote server application. If the **ca\_match** parameter is set to **Yes**, the MFCL Server checks the MFCL Clients for the correct name of the server application. Connection attempts with incorrect names are rejected.

**connection\_type**

Specifies how the connection is established through a keyword. Valid keywords are **TCP/IP** for a TCP/IP connection, **SNA** for an APPC connection, and **LOCAL** for local message processing through the local MFCL Server.

**Additional Parameters:**

Additionally, you can set the following parameters:

- To activate trace files, set **dts\_trace\_dir** or **dts\_trace\_file** on the MFCL Client side.
- To specify the trace level, set **dts\_trace\_level**. You can set the trace level separately for each MFCL Server node.
- To activate the **TCP\_NODELAY** flag, set **tcp\_nodelay**. You can set this parameter for each MFCL Server node.
- To provide additional information in the logon panel of each server application, set **informal\_name** for the name of the server application. You can then see the server name in the pull-down menu of the MERVAs Message Processing Client logon panel. You can also set **free\_form\_name** for other additional information.
- To change the MERVAs message-processing table, set **msg\_proc\_table**. The default table is **MERVASON.MRT**.
- To specify encryption methods, set **encryption**. You can set this parameter separately for each MFCL Client.
- To specify a security key modifier, set **sec\_key\_modifier**.
- To specify a timeout value for the MFCL Server, set **cp\_timeout**.
- To get a prompt window for the conversation security user ID and password of a TCP/IP connection, set **cvsec\_prompt**.

## General DTS Profile Structure of an MFCL Client

The DTS profile consists of node resource groups (**LNODE**, **SNODE**, and **CNODE**) that can have one or more application resource groups (**APPL**).

The following parameter groups are valid:

**LNODE**

Contains the node parameters of the local MFCL Client or MFCL Server.

**SNODE**

Contains the server node parameters of an MFCL Client.

**CNODE**

Contains the client node parameters of an MFCL Server.

**APPL**

Contains application parameters of an MFCL Client or an MFCL Server.

A **NODE** parameter group contains the name and other parameters of the MFCL Client or MFCL Server node. An **APPL** parameter group contains the name and other parameters of a client or server application within this node.

The following section shows you a skeleton of a DTS profile in the MFCL Client environment (Windows NT):

```

#-----
#
# MFCL Client DTS Profile (Example)
#
#-----

LNODE:                Local MFCL Client Node
                      MFCL Client Node Name
                      local_node_name = CN
                      ...
    APPL:              Local Client Application
                      Client Application Name
                      application_name = CA1
                      ...
    APPL:              Local Server Application
                      Client Application Name
                      application_name = CA2
                      ...
SNODE:                Remote MFCL Server Node
                      MFCL Server Node Name
                      server_node_name = SN1
                      ...
    APPL:              Remote Server Application
                      Server Application Name
                      application_name = S1A1
                      ...
    APPL:              Remote Server Application
                      Server Application Name
                      application_name = S1A2
                      ...
SNODE:                Remote Server Node
                      MFCL Server Node Name
                      server_node_name = SN2
                      ...
    APPL:              Remote Server Application
                      Server Application Name
                      application_name = S2A1
                      ...
    APPL:              Remote Server Application
                      Server Application Name
                      application_name = S2A2
                      ...
#-----

```

This profile contains the following node resource groups:

- LNODE (local node parameters)
- SNODE (server node parameters for server 1)
- SNODE (server node parameters for server 2)

#### Local Node Resource Group (LNODE)

The first node resource group contains information about the local MFCL Client node. In this example, the local MFCL Client node is a server node at the same time. It begins with the node resource group identifier **LNODE**. The node parameter group of this node resource group follows the node resource group identifier. A DTS profile can contain only one local node resource group.

The node parameter group is followed by two application parameter groups, each beginning with the application parameter group identifier **APPL**.

The local node resource group end is indicated by the beginning of the second node resource group.

#### Local Node Parameter Group

This group begins with the mandatory local node name parameter

statement. The local node parameter group ends with the beginning of the first application parameter group.

### Local Application Parameter Groups

These groups begin with the application parameter group identifier **APPL**. Local application parameter statements follow.

In this example, the first local application parameter group ends with the beginning of the second application parameter group. The second local application parameter group ends with the next server node resource group.

### Server Node Resource Groups (SNODE)

The second and the third node resource groups contain information about remote MFCL Server nodes. MFCL Server node resource groups begin with the node resource group identifier **SNODE**. The internal structure of an MFCL Server node resource group is identical to the internal structure of a local node resource group.

The end of the DTS profile defines the end of the last application parameter group and the end of the last node resource group.

## General DTS Profile Structure of an MFCL Server

The following section shows you a skeleton of a DTS profile in the MFCL Server environment (Windows NT):

```
#####  
#  
# MFCL Server DTS Profile (Example)  
#  
#####  
LNODE:                                Local MFCL Server Node  
    local_node_name = SN              MFCL Server Node Name  
    ...  
    APPL:                               Local Server Application  
        application_name = SA1         Server Application Name  
        ...  
CNODE:                                Remote MFCL Client Node  
    client_node_name = CN1            MFCL Client Node Name  
    ...  
    APPL:                               Remote Client Application  
        application_name = C1A1        Client Application Name  
        ...  
    APPL:                               Remote Client Application  
        application_name = C1A2        Client Application Name  
        ...  
CNODE:                                Remote Client Node  
    client_node_name = CN2            MFCL Client Node Name  
    ...  
    APPL:                               Remote Client Application  
        application_name = C2A1        Client Application Name  
        ...  
#####
```

This profile contains the following resource groups:

- LNODE (local node parameters)
- CNODE (client node parameters for client 1)
- CNODE (client node parameters for client 2)

### Local Node Resource Group

The first node resource group contains information about the local MFCL

Server node. It begins with the node resource group identifier **LNODE**. The unique node parameter group of this node resource group follows the node resource group identifier.

The node parameter group is followed by one application parameter group that begins with the application parameter group identifier **APPL**.

The local node resource group end is indicated by the beginning of the second node resource group.

#### **Local Node Parameter Group**

This group begins with the mandatory local node name parameter statement. Parameters of the succeeding application parameter groups cannot be referred to if a local node name is not specified.

The local node parameter group ends with the beginning of the first application parameter group.

#### **Local Application Parameter Groups**

These groups begin with the application parameter group identifier **APPL**. Local application parameter statements follow.

The first local application parameter group ends with the beginning of the second application parameter group. The second application parameter group ends with the beginning of the first MFCL Client node resource group.

#### **Client Node Resource Groups**

The second and the third node resource groups contain information about remote MFCL Client nodes. MFCL Client node resource groups begin with the node resource group identifier **CNODE**. The internal structure of an MFCL Client node resource group is identical to the internal structure of a local node resource group.

The end of the DTS profile defines the end of the last application parameter group and the end of the last node resource group.

## **General DTS Profile Structure of MFCL Client/MFCL Server**

The following section shows you a skeleton of a DTS profile of a node that has an MFCL Client and an MFCL Server environment (Windows NT):

```
#####  
#  
# MFCL Client/Server DTS Profile (Example)  
#  
#-----  
LNODE:                                Local Merva Server Node  
    local_node_name = SN              Merva Server Node Name  
    ...  
    APPL:                               Local Client Application  
    application_name = CA1            Client Application Name  
    ...  
    APPL:                               Local Server Application  
    application_name = SA1            Server Application Name  
    ...  
CNODE:                                Remote MFCL Client Node  
    client_node_name = CN1            MFCL Client Node Name  
    ...  
    APPL:                               Remote Client Application  
    application_name = C1A1           Client Application Name  
    ...  
    APPL:                               Remote Client Application  
    application_name = C1A2           Client Application Name  
    ...
```

```

SNODE:          server_node_name = SN1      Remote MFCL Server Node
              MFCL Server Node Name
              ...
APPL:           application_name = S1A1     Remote Server Application
              Server Application Name
              ...
APPL:           application_name = S1A2     Remote Server Application
              Server Application Name
              ...
#=====

```

For a description of the parameters refer to “General DTS Profile Structure of an MFCL Client” on page 127 and “General DTS Profile Structure of an MFCL Server” on page 129.

## DTS Profile Contents (MFCL Client)

This section describes the information that can be contained in a parameter group of an MFCL Client DTS profile.

### Local Node (LNODE Parameter Group)

A local node parameter group in the MFCL Client environment contains local MFCL Client node parameters. The local node parameters are:

#### **local\_node\_name**

Specifies the name of the local node.

The local node names must be unique for all interconnected MERVVA Client systems. You can specify other local node names as you like. A local node name consists of up to eight alphanumeric characters beginning with an alphabetic character. Upper- and lowercase letters have the same meaning. For example, **NODE1** and **node1** identify the same node.

#### **dts\_trace\_dir**

Specifies the name of the MFCL Client DTS Diagnosis Trace Directory.

Processing trace files created by the MFCL Client DTS programs are written to this directory. The name of the created trace files begins with the application name. The extension of the file name is a number between **000** and **999**. For example, the name of the third trace file of the application **SA1** is **SA.002**.

You must specify the name of the diagnosis trace directory as an absolute path name, a relative path name, or a network path name. According to the rules of your operating system, each path name ends with a forward slash or a backslash. Otherwise, an error occurs.

#### **dts\_trace\_file**

Specifies the name of the MFCL Client DTS processing trace file.

A DTS process writes its diagnosis trace into this file. If the file does not exist, it is created. If the file exists, it is cleared at the beginning of a DTS process.

You must specify the name of the diagnosis trace file as a full path name, a relative path name, or a network path name. If parameter data ends with a forward slash or a backslash, an error occurs.

You can define the name of the trace files by using **dts\_trace\_dir** or by using **dts\_trace\_file**. If both parameters are specified, the last one in the DTS profile is valid.

### **dts\_trace\_level**

Specifies whether an MFCL Client DTS processing trace is requested. Specifies also the trace details.

The trace level specified in this parameter is the default trace level for all MFCL Client DTS processes. You can overwrite the default trace level for a specific MFCL Client DTS process by setting the **dts\_trace\_level** parameter of a parameter group of a MERVA Server application.

Valid parameter values are:

- 0 No trace is created. This is the default value.
- 1 A trace that contains information about process activities of the MFCL Client is created. The trace does not show transfer data elements.
- 2 A trace that contains each data of a level-1 trace and transfer data envelopes (outbound and inbound control data) is created.
- 3 A trace that contains each data of a level-2 trace and up to 1024 bytes of the transfer data (outbound and inbound data) is created. This trace shows also information related to data communication service calls.

The trace is written to the file that is specified by the **dts\_trace\_file** parameter or to a file in the trace directory that is specified by the **dts\_trace\_dir** parameter.

### **Local Application (APPL Parameter Group)**

A local application parameter group in the MFCL Client environment contains information that depends on the local client application. The client application parameters are:

#### **application\_name**

Specifies the name of a local client application.

The attributes of a client application name are identical to the attributes of a local node name.

### **MFCL Server Node (SNODE Parameter Group)**

An MFCL Server node parameter group in the MFCL Client environment contains remote MFCL Server node parameters. The MFCL Server node parameters are:

#### **server\_node\_name**

Specifies the name of an MFCL Server node.

The attributes of an MFCL Server node name are identical to the attributes of a local node name.

#### **symb\_destination**

Specifies the name of an SNA APPC side information profile that contains SNA APPC related control information about the MFCL Server process.

#### **partner\_host**

Specifies the name or the IP address of the TCP/IP host to which the MFCL Server belongs.

You must specify the IP address in dotted-decimal representation. The maximum length of the partner host information is 16 characters.

**port\_number**

Specifies the TCP/IP port number for the Internet subserver that represents the MFCL Server in the MFCL Server system.

The sample and default port number for the MFCL Server in the TCP/IP environment is 7117. The maximum value of a TCP/IP port number is 65.535.

**tcp\_nodelay**

Specifies whether the **tcp\_nodelay** parameter must be set for the outbound socket.

The outbound socket is used for communication with the MFCL Server process. This parameter can affect the performance of the data communication. Valid parameter values are **off**, **on**, **0**, and **1**. The default parameter value is **1**.

**Server Application (APPL Parameter Group)**

A server application parameter group in the MFCL Client environment contains information that defines the characteristics of a specific MERVA server application. The information applies to the MFCL Client part, to the MFCL Server part, or to both parts of the application.

The server application parameters are:

**application\_name**

Specifies the formal name of a remote MERVA server application.

Formal names of a server application must be unique within an MFCL Server node resource group. The attributes of a formal name of a server application are identical to the attributes of a local node name.

**cvsec\_prompt**

Specifies whether the MERVA Client Logon window contains an additional user ID and password prompt for a TCP/IP connection.

The additional password is used for the conversation security check. This check is performed while the connection on the MFCL Server side takes place. By default, the **cvsec\_prompt** parameter is set to **No**. In this case, your MERVA user ID and password are used for the conversation security check. The conversation security user ID and password must match the appropriate system user ID and password on the target MERVA server to get a TCP/IP connection.

**informal\_name**

Specifies the informal name of a remote MERVA server application.

Informal names of a server application must be unique within the MFCL Client system. You can use an informal name of a server application as a nickname to identify a server application in MFCL Client user terms. An informal name of a server application consists of a maximum of eight non-white printable characters. Upper- and lowercase characters have different meanings.

**free\_form\_name**

Specifies the free-form name of a remote server application.

You can use a free-form name of a server application to explain the purpose of a server application in MFCL Client user terms. A free-form name of a server application consists of a maximum of 64 printable characters, including blanks. You must specify all free-form name characters in the same line as the parameter keyword.

**msg\_proc\_table**

Specifies the name of the message-processing table that the MFCL Client message-processing entity must use when it communicates with this MERVA server application.

If this parameter is not specified, the default name of the message-processing table is **MERVASON.MRT**.

**connection\_type**

Specifies the type of connection to the partner system.

You must define the connection type of each application explicitly. If the connection type is not set, or if the parameters of the selected connection type are not sufficient, an error is reported. The connection type value is one of the following:

**LOCAL**

The connection type is the connection to the local MFCL Server.

**SNA** The connection type is SNA APPC (remote MFCL Server).

**TCP/IP**

The connection type is TCP/IP (remote MFCL Server).

**encryption**

Specifies the method that must be used for encryption of MERVA application data that the MFCL Client sends to the MFCL Server.

The encryption parameter value is one of the following:

**NONE**

MERVA application data is not encrypted.

This is the default.

**MFC** The MFCL Client proprietary method is used for encryption of MERVA application data.

**sec\_key\_modifier**

Specifies the security key modifier of the MERVA application data that must be used for encryption of MERVA application data.

The parameter value of the security key modifier can be a string of one character, up to eight numeric characters. You must specify the same parameter value in the applicable client APPL parameter group in the MFCL Server system. If the MFCL Client and the MFCL Server system use the same character encoding (ASCII or EBCDIC), you can use any character, up to eight characters, as security key modifier. If this parameter is not specified or if it is specified as zero (any number of zero characters), security key modification of application data is not applicable.

**cp\_timeout**

Specifies the timeout value for an MFCL Client process that communicates with the MFCL Server application.

After the MFCL Client sends data to the MFCL Server, it expects a response within a specific period of time. If the MFCL Server does not respond within this period of time, the MFCL Client DTS interrupts the communication and informs the MFCL Client application about the timeout, that is, the MFCL Server did not respond in time.

The timeout value specifies the number of seconds that the DTS waits for a response from the MFCL Server. A timeout value of zero means that the



communication is not interrupted if the server does not respond in time. The default timeout value is 60 seconds.

#### **dts\_trace\_level**

Specifies whether an MFCL Client DTS processing trace is requested. Specifies also trace details.

The trace level specified in this parameter overwrites the trace level specified in the local node parameter group for an MFCL Client DTS process that is connected to the MFCL Server application. It also overwrites an explicitly specified trace level.

The valid parameter values are identical to the **dts\_trace\_level** parameter values that can be specified in a local node parameter group.

## **DTS Profile Contents (MFCL Server)**

The information that can be contained in a parameter group of an MFCL Server DTS profile is described in the following sections.

### **Local Node (LNODE Parameter Group)**

A local node parameter group in the MFCL Server environment contains local MFCL Server node parameters. The local node parameters are:

#### **local\_node\_name**

Specifies the name of the local node.

The local node names must be unique for all interconnected MERVVA Client systems. You can specify other local node names as you like. A local node name consists of up to eight alphanumeric characters beginning with an alphabetic character. Upper- and lowercase letters have the same meaning. For example, **NODE1** and **node1** identify the same node.

#### **sa\_match**

Specifies whether the MERVVA server application name received from the MFCL Client in the connect request must be verified.

The parameter value is one of the following:

- Yes** The MERVVA server application name must be verified. The name of the MERVVA server application received from the MFCL Client must match the name of a local MERVVA server application defined in the local MFCL Server resource group. If the name of the MERVVA server application cannot be verified, the connect request is rejected.
- No** This is the default value. The name of the MERVVA server application received from the MFCL Client does not have to match the name of a local MERVVA server application defined in the local MFCL Server resource group. The local MERVVA server application parameters of an explicitly identified MERVVA server application apply. Otherwise, default parameters of the MERVVA server application apply.

#### **ca\_match**

Specifies whether the address information about the MFCL Client received from the MFCL Client in the connect request must be verified.

The parameter value is one of the following:

- Yes** The MFCL Client address information is verified and must match definitions in the DTS profile. The MFCL Client node name received from the MFCL Client must match the name of an MFCL

Client node defined in this DTS profile. The client application name received from the MFCL Client must match the name of a client application defined in a client application parameter group within the scope of the applicable client node resource group. If one of the two client resources is not defined in the DTS profile, a connect request is rejected.

**No** The client address information does not have to match definitions in the DTS profile. The MFCL Client node name received from the MFCL Client does not have to match the name of an MFCL Client node defined in an MFCL Client node parameter group. The MFCL Client node parameters of an explicitly identified MFCL Client node apply. Otherwise, default MFCL Client node parameters apply.

The client application name received from the MFCL Client does not have to match the name of a client application defined in a client application parameter group. The client application parameters of an explicitly identified client application parameter group within the scope of the applicable MFCL Client node resource group apply. Otherwise, default client application parameters apply.

### **Local Application (APPL Parameter Group)**

A local application parameter group in the MFCL Server environment contains information that depends on local MERVA server application. The MERVA server application parameters are:

#### **application\_name**

Specifies the name of a local MERVA server application. The attributes of a MERVA server application name are identical to the attributes of a local node name.

### **MFCL Client Node (CNODE Parameter Group)**

An MFCL Client node parameter group in the MFCL Server environment contains remote MFCL Client node parameters. The MFCL Client node parameters are:

#### **client\_node\_name**

Specifies the name of an MFCL Client node.

The attributes of an MFCL Client node name are identical to the attributes of a local node name.

### **Client Application (APPL Parameter Group)**

A client application parameter group in the MFCL Server environment contains remote client application dependent information. The client application parameters are:

#### **application\_name**

Specifies the name of a remote client application.

The attributes of a client application name are identical to the attributes of a local node name.

#### **encryption**

Specifies the method that must be used for encryption of MERVA application data that the MFCL Server sends to the MFCL Client.

The encryption parameter value is one of the following:

#### **NONE**

MERVA application data is not encrypted. This is the default value.

**MFC** The MFCL Client proprietary method is used for encryption of MERVA application data.

**sec\_key\_modifier**

Specifies the security key modifier of the MERVA application data that must be used for encryption of MERVA application data.

The parameter value of the security key modifier can be a string of one character, up to eight numeric characters. You must specify the same parameter value in the applicable server APPL parameter group in the MFCL Client system. If the MFCL Client and the MFCL Server system use the same character encoding (ASCII or EBCDIC), you can use any character, up to eight characters, as security key modifier. If this parameter is not specified or if it is specified as zero (any number of zero characters), security key modification of application data is not applicable.

**sp\_timeout**

Specifies the timeout value for an MFCL Server process when it communicates with the MFCL Client application.

After the MFCL Server sends response data to the MFCL Client, it expects another request within a specific period of time. If the client does not send another request within this period of time, the MERVA server application is stopped. An active client automatically creates a blank message within this time period even if the client and the server do not communicate with each other.

The timeout value specifies the number of seconds that the DTS waits for another request from the MFCL Client. A timeout value of zero means that the MERVA server application is not stopped because the client does not send another request in time. The default timeout value is 10 minutes.

## DTS Profile Implementation

The implementation of the MERVA Family Client DTS profile depends on the operating system environment.

### DTS Profile Implementation in MVS and VSE

The MFCL Server DTS profile is implemented in the MVS (TM) and VSE environments as a fixed data table that you cannot change.

The following values determine the behavior of a MERVA ESA server:

**sa\_match**

No

**ca\_match**

No

**encryption**

Determined by the MFCL Client's connect request (**NONE** or **MFC**)

**sec\_key\_modifier**

Not supported

**sp\_timeout**

Not supported

### DTS Profile Implementation on Windows NT

The MERVA Family Client DTS profile is implemented in the Windows NT environment as a flat file with text parameters. The profile is created by using a text editor.

## A MERVA Family Client DTS Sample Configuration

The following figure shows you a sample topology of an MERVA Family Client configuration:

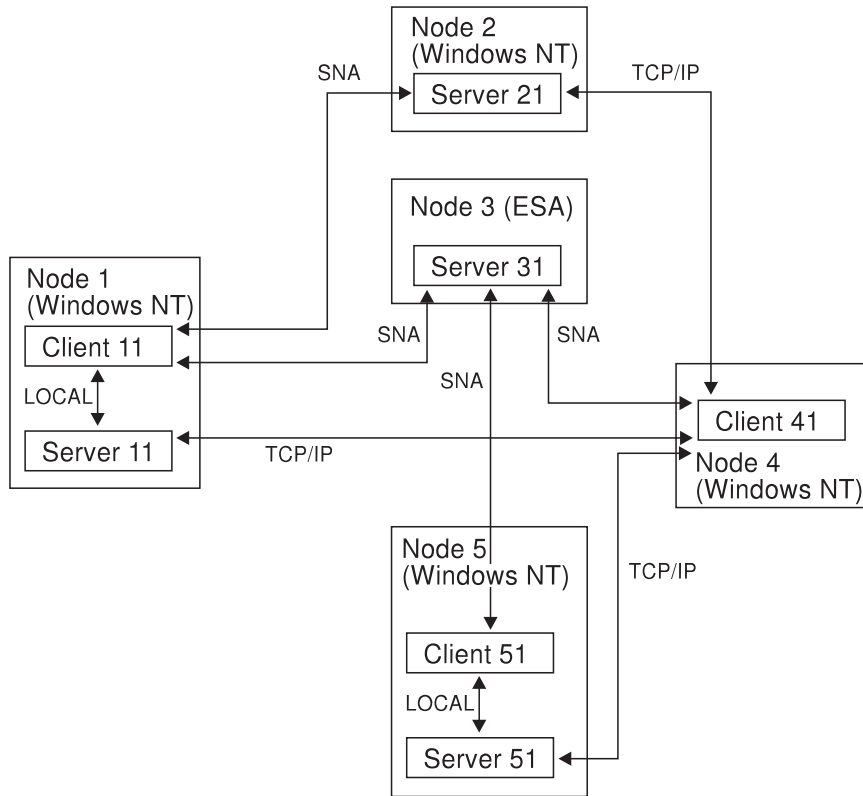

Figure 43. MERVA Family Client Sample Topology

For this sample configuration, the following DTS profile samples are valid customizations:

### DTS Profile of Node 1

```

=====
# MERVA Family Client DTS Profile (Node 1)
=====

#-----
# Local Node Definitions for both, an MFCL Client and a Server Node
#-----

LNODE:
    local_node_name      = NODE1      Local client and server node
    dts_trace_dir        = c:\temp\trace\
    sa_match              = no        server appl. need not match
    ca_match              = yes        client appl. must match

APPL:
    application_name     = CLIENT11   local client application

APPL:
    application_name     = SERVER11   local server application

#-----
# Local Server Node Definition for a Client Node
#-----

```

```

SNODE:
    server_node_name = NODE1      local server node (Node 1)
                                server node name

APPL:
    application_name = SERVER11    local server application
                                server application formal name
    informal_name    = MUBLOCAL    server application nickname
    free_form_name   = MERVA USE & Branch local server
    connection_type  = LOCAL       preferred connection type
    cp_timeout       = 30          outbound timeout

```

```

#-----
# Remote Server Node Definitions for a Client Node
#-----

```

```

SNODE:
    server_node_name = NODE2      remote server node (Node 2)
                                server node name
    symb_destination = NODE2PC    symbolic destination

APPL:
    application_name = SERVER21    remote server application
                                server application formal name
    informal_name    = MUBSERV    server application nickname
    free_form_name   = MERVA USE & Branch at Node 2
    connection_type  = SNA        preferred connection type
    encryption       = MFC        method for encryption
    cp_timeout       = 60         outbound timeout

```

```

SNODE:
    server_node_name = NODE3      remote server node (Node 3)
                                server node name
    symb_destination = NODE3PC    symbolic destination

APPL:
    application_name = SERVER31    remote server application
                                server application formal name
    informal_name    = ESASERV    server application nickname
    free_form_name   = MERVA ESA  server at Node 3
    connection_type  = SNA        preferred connection type
    encryption       = MFC        method for encryption

```

```

#-----
# Remote Client Node Definitions for a Server Node
#-----

```

```

CNODE:
    client_node_name = NODE4      remote client node (Node 4)
                                client node name

APPL:
    application_name = CLIENT41    remote client application
                                client application formal name
    encryption       = NONE        method for encryption
    sp_timeout       = 120         next request timeout

```

```

#=====
# MERVA Family Client DTS Profile End
#=====

```

## DTS Profile of Node 2

```

#=====
# MERVA Family Client DTS Profile (Node 2)
#=====

```

```

#-----
# Local Node Definitions for a Server Node
#-----

```

```

LNODE:
    local_node_name = NODE2      local Node 2 is a server node
                                Local server node name
    sa_match         = yes        server application must match
    ca_match         = no         client appl. need not match

```

```

APPL:                                local server application
      application_name = SERVER21
      msg_proc_table  = MERVASON.MRT

```

```

=====
# MERVA Family Client DTS Profile End
=====

```

**DTS DB of Node 3:** No customization possible.

**DTS DB of Node 4:**

```

=====
# MERVA Family Client DTS Profile (Node 4)
=====

```

```

#-----
# Local Node Definitions for a Client Node
#-----

```

```

LNODE:                                local Node 4 is a client node
      local_node_name = NODE4      Local client node name
      dts_trace_level = 0          level = 0 : write no trace
      ca_match        = no         client appl. need not match.

```

```

APPL:                                local client application
      application_name = CLIENT41

```

```

#-----
# Remote Server Node Definitions for a Client Node
#-----

```

```

SNODE:                                remote server node (Node 2)
      server_node_name = NODE2      server node name
      partner_host     = node2      partner host name
      port_number      = 7117      TCP/IP port
      tcp_nodelay     = on         TCP_NODELAY opt. for outbound

```

```

APPL:                                remote server application
      application_name = SERVER21    server application formal name
      informal_name   = MUBSERV     server application nickname
      free_form_name  = MERVA USE & Branch at Node 2
      connection_type = TCP/IP     preferred connection type
      encryption      = MFC         method for encryption
      cp_timeout      = 60         outbound timeout

```

```

SNODE:                                remote server node (Node 3)
      server_node_name = NODE3      server node name
      symb_destination = NODE3PC    symbolic destination name

```

```

APPL:                                remote server application
      application_name = SERVER31    server application formal name
      informal_name   = ESASERV     server application nickname
      free_form_name  = MERVA ESA   server at Node 3
      connection_type = SNA        preferred connection type
      encryption      = MFC         method for encryption
      cp_timeout      = 60         outbound timeout

```

```

SNODE:                                remote server node (Node 1)
      server_node_name = NODE1      server node name
      partner_host     = node1      partner host name
      port_number      = 7117      TCP/IP port
      tcp_nodelay     = on         TCP_NODELAY opt. for outbound

```

```

APPL:                                remote server application

```

```

        application_name = SERVER11 server application formal name
        informal_name    = NTSERV  server application nickname
        free_form_name   = MERVA USE & Branch at Node 1
        connection_type  = TCP/IP  preferred connection type
        encryption       = NONE    method for encryption
        cp_timeout       = 60      outbound timeout

```

```

SNODE:
    server_node_name = NODE5    remote server node (Node 5)
                        server node name

```

```

APPL:
    application_name = SERVER51  remote server application
                        server application formal name
    informal_name    = MERVANT  server application nickname
    free_form_name   = MERVA Workstation server at Node 5
    connection_type  = TCP/IP  preferred connection type
    encryption       = MFC

```

```

=====
# MERVA Family Client DTS Profile End
=====

```

### DTS DB of Node 5:

```

=====
# MERVA Family Client DTS Profile (Node 5)
=====

```

```

#-----
# Local Node Definitions for both, an MFCL Client and a Server Node
#-----

```

```

LNODE:
    local_node_name = NODE5    local Node 5
                        local client and server node
    dts_trace_dir   = c:\temp\trace\
    sa_match        = no       server appl. need not match
    ca_match        = no       client appl. need not match

```

```

APPL:
    application_name = CLIENT51 local client application

```

```

APPL:
    application_name = SERVER51 local server application

```

```

#-----
# Local Server Node Definition for a Client Node
#-----

```

```

SNODE:
    server_node_name = NODE5    local server node (Node 5)
                        server node name

```

```

APPL:
    application_name = SERVER51  local server application
                        server application formal name
    informal_name    = MERVANT  server application nickname
    free_form_name   = MERVA Workstation local server
    connection_type  = LOCAL    preferred connection type

```

```

#-----
# Remote Server Node Definition for a Client Node
#-----

```

```

SNODE:
    server_node_name = NODE3    remote server node (Node 3)
                        server node name
    symb_destination = NODE3PC  symbolic destination name

```

```

APPL:
    application_name = SERVER31  remote server application
                        server application formal name

```

informal\_name = ESASERV server application nickname  
free\_form\_name = MERVA ESA server at Node 3  
connection\_type = SNA preferred connection type  
encryption = MFC

---



---

## Appendix B. Diagnosing Problems

This section describes how to get diagnosis information for the MERVA Message Processing Client. Diagnosis information within the MERVA Message Processing Client is provided in the form of log files stored on the workstation where the reporting component of the MERVA Message Processing Client is installed. For the location of these files refer to the corresponding *MERVA Installation and Customization Guides*. The purpose of diagnosis information is to help you locate the reason for any problem that might occur.

---

### The MERVA Message Processing Client Log Files

The MERVA Message Processing Client, hereafter called Client, comprises several cooperating components, each with its own log file, as shown in the following figure:

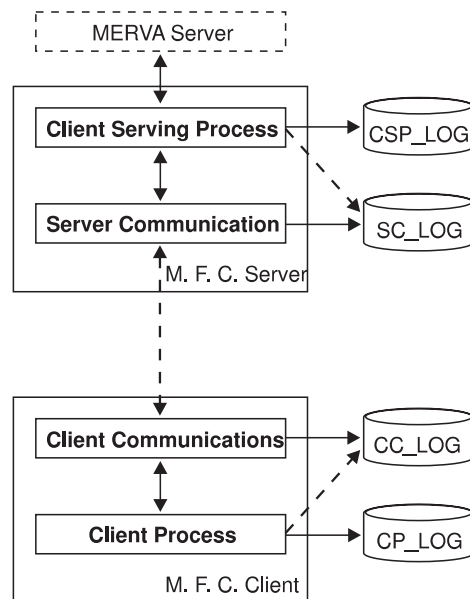

Figure 44. The Log Files of the Components of the MERVA Message Processing Client

The real names of the log files as shown in this figure depend on the respective MERVA Message Processing Client configuration. The names are determined in the following table:

Table 4. MERVA Message Processing Client Log File Names

| Configuration                               | CP_LOG   | CSP_LOG  | CC_LOG   | SC_LOG  |
|---|--|--|--|---|
| Remote Client with MERVA ESA server         | As specified in the user settings or with the parameter <b>/tracefile=</b> | The CSP_LOG is identical with the MERVA ESA journal  | As specified with the parameter <b>informal_name</b> in the <b>ENCTDTS.PRF</b> profile of the workstation extended by '.' and three digits (instance counter)  | The SC_LOG is identical with the MERVA ESA journal  |
| Remote Client with MERVA Workstation server | As specified in the user settings or with the parameter <b>/tracefile=</b> | File name derived from the client's LU6.2 name (SNA) or the client's symbolic host name (TCP/IP) on server workstation (*.LOG) | As specified with the parameter <b>informal_name</b> in the <b>ENCTDTS.PRF</b> profile of the workstation, extended by '.' and three digits (instance counter) | Derived from the host name of the client (TCP/IP), extended by '.' and three digits (instance counter)  |
| Local Client                                | As specified in the user settings  | As specified in the user settings  | As specified with the parameter <b>informal_name</b> in the <b>ENCTDTS.PRF</b> profile of the workstation extended by '.' and three digits (instance counter)  | As specified with the parameter <b>informal_name</b> in the <b>ENCTDTS.PRF</b> profile of the workstation extended by '.' and three digits (instance counter) |

## The Client Diagnosis Log

The client diagnosis logs **CP\_LOG** and **CSP\_LOG** contain three classes of information:

- Log file entries that are characterized by the "-X->" signal report on exceptional situations. In case of problem tracking, these entries should be analyzed by you and your IBM representative.
- Log file entries that are characterized by the "-T->" signal report internal trace data. In case of severe problems, these entries should be analyzed by your IBM representative.
- All other log file entries report problems in your setup that should be solved without IBM support.

The following table shows you a classification of all customer-oriented entries in the log file:

Table 5. MERVA Message Processing Client Customer-Oriented Logging Classes

| Signal | Logging Class  |
|--------|--|
| -E->   | Trace and error reports of the client's End User Interface Component |
| -M->   | Trace and error reports of the client's Message-Processing Component |

You can display and edit the log file by using any standard ASCII text editor.

**Note:** Do not edit the file if any component of the MERVA Message Processing Client on your workstation is active.

The following shows you an example of a client diagnosis log file that is displayed by an ASCII text editor:

```
-T-> 05/07/1997 08:44:36    111    IThread(1)
(+) EncAPIUser_1

-T-> 05/07/1997 08:44:36    111    IThread(1)
> Sign on to server [EncAPIUser_1]
  UserID="hho"
  UserOldPW="*****"
  UserNewPW="*****"

-T-> 05/07/1997 08:44:37    111    IThread(3)
> Send request to server [EncAPIClientComm_1]
  ServerRequest(1)="SIGNON hho ***** ()"

-T-> 05/07/1997 08:44:42    111    IThread(3)
* Request execution at server [EncAPIServerComm_1]
  ClientID="CA1 at HHONODE"  ExecuteIndication="EXECUTED"
  ServerRequest="SIGNON hho ***** ()"
  ServerReply="0 IBMMERVA2 "" US ((SWIFTC1 (100)))"

...

-T-> 05/07/1997 08:44:43    111    IThread(1)
(+) EncCMessageBox_4

-T-> 05/07/1997 08:44:43    111    IThread(1)
(+) EncCFunctionList_1

-T-> 05/07/1997 08:44:43    111    IThread(1)
(+) EncAPIUserExit_1

-T-> 05/07/1997 08:44:43    111    IThread(1)
> Execute user exit [EncAPIUserExit_1]
  UserExitID="AccessCurrencyCodes"
  InputData=":REQTYP:LIST"

-T-> 05/07/1997 08:44:43    111    IThread(3)
> Send request to server [EncAPIClientComm_1]
  ServerRequest(2)="EXECUTEUSEREXIT AccessCurrencyCodes enm2lux :REQTYP:LIST"

...

-T-> 05/07/1997 08:44:43    111    IThread(3)
* Request execution at server [EncAPIServerComm_1]
  ClientID="CA1 at HHONODE"  ExecuteIndication="EXECUTED"
  ServerRequest="EXECUTEUSEREXIT AccessCurrencyCodes enm2lux :REQTYP:LIST"
  ServerReply="9999 ""

...

-T-> 05/07/1997 08:44:44    111    IThread(3)
(!) EncAPIUserExit_1 EncAPIUserExit::outputData
```

```

-X-> 05/07/1997 08:44:44    111    IThread(1)
EncAPIUserExitError exception thrown.
  function: EncAPIUserExit::getExecuteReply()
  file: encaexit.cpv
  line: 72
  Error Id is 181
  Error Code group is ENCApiUserExitServices
  Exception text is:
    ENC0181: Execute of user exit not accepted: Server's RC=9999 [].
    9999

-T-> 05/07/1997 08:44:44    111    IThread(1)
(+) EncCMessageBox_5

-T-> 05/07/1997 08:44:44    111    IThread(1)
(-) EncCMessageBox_5

-T-> 05/07/1997 08:44:44    111    IThread(1)
(-) EncAPIUserExit_1

-T-> 05/07/1997 08:44:49    111    IThread(1)
> Get server MP tables' signature [EncAPIServer_1]
  ServerID="MFCL at HHONODE"

-T-> 05/07/1997 08:44:49    111    IThread(3)
> Send request to server [EncAPIClientComm_1]
  ServerRequest(3)="GETTABLESIGNATURE"

```

There are two types of log file entries. For details see “Exception Messages” and “Trace Messages” on page 147.

## Exception Messages

Exception messages are log file entries that report exceptional situations such as not valid data or unexpected system behavior. In case of problems with the MERVA Message Processing Client, this data helps you find out the effect of the problem.

Each exception entry in the log file has the structure shown in the following figure:

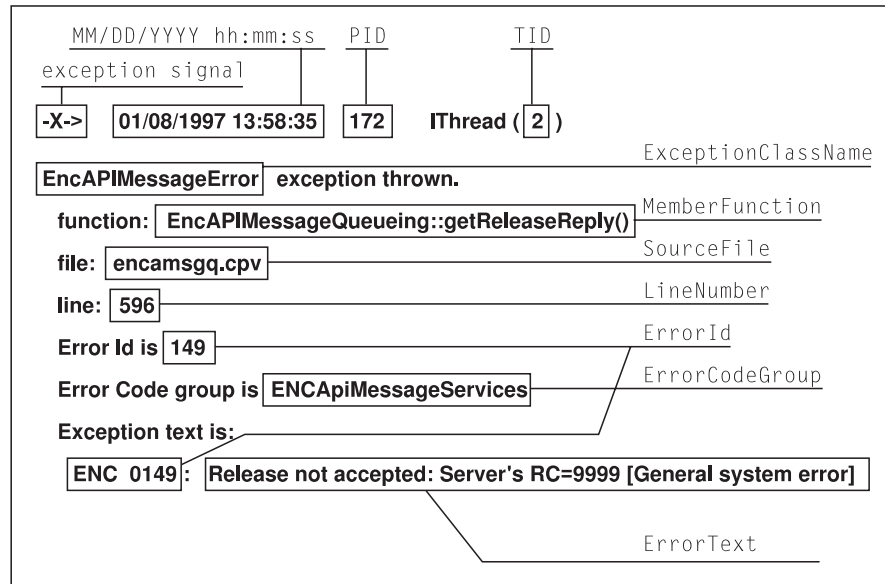

Figure 45. The Structure of Exception Messages

The following list explains the terms used in the figure:

**MM/DD/YYYY hh:mm:ss**

Time stamp that indicates date and time when the log entry is created.

**PID** Identification of the process that creates the log entry.

**TID** Identification of the thread that creates the log entry.

**ExceptionClassName**

Name of the exception class to which the error belongs.

**MemberFunction**

Class member function that throws the exception.

**SourceFile**

Name of the source file from which the throwing function is called.

**LineNumber**

Line number that is related to the source file in which the call of the throwing function is placed.

**ErrorID**

Error identification that restricts the error within the exception class. It might be used to identify the error message in *Messages and Codes* to help you solve the problem.

**ErrorCodeGroup**

Assigns the error to a specific group of errors. Usually, this group is identical with the exception class.

**ErrorText**

Explains why the message is displayed. The text contains variable text that describes the surrounding conditions of the error.

## Trace Messages

Trace messages are log file entries that describe processed data and regular system behavior. In case of problems with the MERVA Message Processing Client, this data helps you find the reason for the problem.

Each trace entry in the log file has the structure of one of the types shown in the following figure:

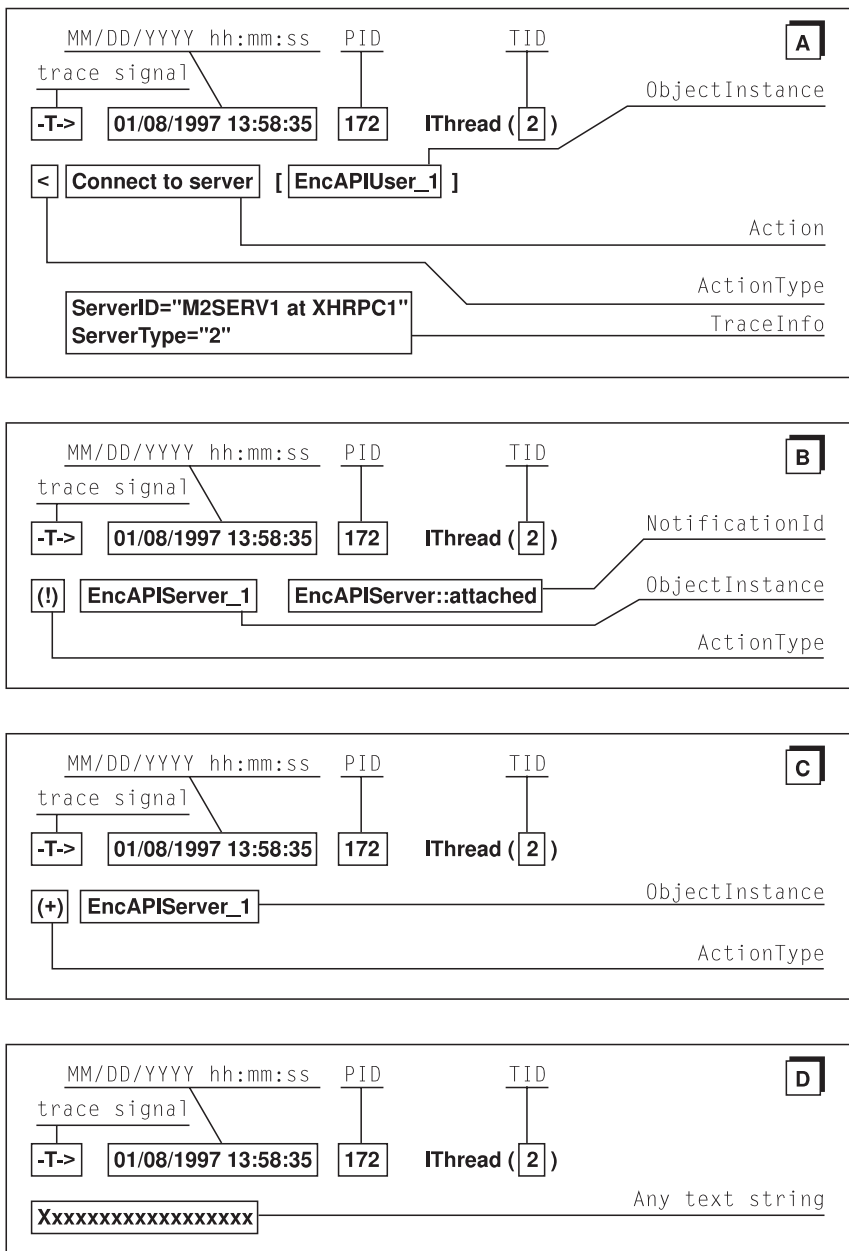

Figure 46. The Structure Types of Trace Messages

The following list explains the terms and their definition used in the figure:

**MM/DD/YYYY hh:mm:ss**

Time stamp that indicates date and time when the log entry is created.

**PID**

Identification of the process that creates the log entry.

**TID**

Identification of the thread that creates the log entry.

**Action Type**

Symbols indicating the state of the action. The following symbols are valid:

- >< Run of a client function (Type A)
- > Entry to a client function (Type A)
- < Return from a client function (Type A)
- \* Run of a server function (Type A)
- (+) Construction of an object (Type C)
- (-) Destruction of an object (Type C)
- (!) Notification on execute completion (Type B)
- Free text trace (Type D)

**Action**

Describes the action.

**ObjectInstance**

Instance name and number of the related object.

**NotificationID**

Shows the identification of the notification.

**TraceInfo**

Shows trace data that corresponds to the action. The number of trace information entries depends on the action traced.

## Communication Diagnosis Log

The DTS diagnosis logs **CC\_LOG** and **SC\_LOG** contain information on the data transfers between clients and servers.

Experienced system specialists should evaluate the related log files because special knowledge about the applied data transfer protocols and the data transfer customization is required. However, looking into the communications log files can help you detect customization errors with respect to the MERV Message Processing Client data transfer components and the SNA or TCP/IP standard software tools used.

Especially while putting a client-server connection into operation, the **CC\_LOG** and **SC\_LOG** contain useful information on the establishment of the connection between client/server and the transfer of application data.

The DTS diagnosis log files contain information on the activities of the MERV Message Processing Client communications components and the transferred data. In case of errors, you can find related information, such as error and sense codes of the applied communications tools. You can then use this information for trouble shooting.

You can display and edit the log files with any standard text editor. Note that you should not edit the file when any component of the MERV Message Processing Client is active on the workstation.

### Example of a Log File without Errors

The following section shows you a sample of records in a communications diagnosis log file displayed by a text editor.

The sample log file shows a sequence of log entries that represent a typical client/server communication activity divided into an initial connection to the server, several data transfers, and a final disconnection.

```
ENCTSO      MERV Family Client process start on Mon Nov 03 11:44:31 1997

ENCTSO      Env var PATH      is C:\WINNT40\system32;C:\WINNT40;E:\CLIENT\CLI\BIN;
ENCTSO      Env var DPATH     is E:\CLIENT\CLI\BIN
```

```

ENCTSO      Env var ENC_DIR is E:\CLIENT\CLI

ENCTSO_crq Connect request parameters printed by ENCTSO_pcr:

ENCTSO_pcr Local client address is MCLIENT at XHRPCNT
ENCTSO_pcr Local system type   is WNT
ENCTSO_pcr Processing trace lvl is 3

ENCTSO_pcr Server appl nickname is XHRPC_CL
ENCTSO_pcr Server address      is MSERVER1 at XHRPC
ENCTSO_pcr Msg processing table is MERVASON.MRT
ENCTSO_pcr Server system type  is OS/2
ENCTSO_pcr Appl data security  is Encryption 0 Authentication 1

ENCTSO_pcr Preferred conn type is TCP/IP, CP timeout is 3000 seconds
ENCTSO_pcr SNA APPC info      is TP '' at 'XHRPC1'
ENCTSO_pcr TCP/IP   info      is Port '7117' at 'xhrpc'

ENCTSO_gcr PDU segment data begin -----*
ENCTSO_gcr 000000 74000001 1A000110 0B0001A1 58485250 * t.....iXHRP *
:
:
ENCTSO_gcr 000070 2E681E6F * .h.o *
ENCTSO_gcr PDU segment data end -----*

ENCTSO_lsp Loading DLL enctco.dll
ENCTSO_lsp DLL enctco was successfully loaded

ENCTCO_soc Service Primitive   is CONNECT.Request
ENCTCO_soc Partner host name   is xhrpc

ENCTCO_soc Connection to xhrpc has been established
ENCTCO_soc TCP_NODELAY flag has been set
ENCTSC_htn Converting outbound PDU segment 0100 to network format
ENCTSC_htn Converting outbound PDU segment 81FF to network format
ENCTCO_scr Connect Request PDU successfully sent

ENCTCO_rcc Receive CC-PDU with a timeout of 3000 seconds
ENCTCO_rds Inbound PDU segment begin is 002A0101 00089200 00000258 000C9201
ENCTSC_nth Converting inbound PDU segment 0101 to host format
ENCTCO_cpt Inbound PDU trailer      is 000581FF F7
ENCTSC_nth Converting inbound PDU segment FF81 to host format
ENCTCO_cpt Change direction trailer received

ENCTCO_rcc Connect Confirmation PDU received

ENCTSO_dcc PDU segment data begin -----*
ENCTSO_dcc 000000 2A000101 08000092 58020000 0C000192 * *......ÆX.....Æ *
:
:
ENCTSO_dcc 000020 B0310800 04921A0E 5E34 * °1...Æ..i4 *
ENCTSO_dcc PDU segment data end -----*
ENCTSO_trm Service primitive completed at Mon Nov 03 11:44:33 1997

--CLIENT--> call outbound function for request "SIGNON"
              to server "MSERVER1 at XHRPC"

ENCTSO_srq Send request received at Mon Nov 03 11:44:33 1997

ENCTSO_pod Application data begin -----*
ENCTSO_pod 000000 5349474E 4F4E202A 2A2A2A2A 2A2A2A2A * SIGNON ***** *
:
:
ENCTSO_pod 000030 2A2A * ** *
ENCTSO_pod Application data end -----*

ENCTSO_gad PDU segment data begin -----*

```



```

ENCTSO_gad 000000 40000201 08000092 32000000 0C000192 * @.....Æ2.....Æ *
:
:
ENCTSO_gad 000030 DD8E4FAC 4E79AC9B 3BD8E90B E4A3BCE2 * |Ä0Nyø;İÚ.õú½ô *
ENCTSO_gad PDU segment data end -----*
ENCTSC_htn Converting outbound PDU segment 0102 to network format
ENCTSC_htn Converting outbound PDU segment 81FF to network format
ENCTCO_sap Application Data PDU successfully sent

ENCTCO_rap Receive AD-PDU with a timeout of 3000 seconds
ENCTCO_rds Inbound PDU segment begin is 00400102 00089200 00000503 000C9201
ENCTSC_nth Converting inbound PDU segment 0201 to host format
ENCTCO_rad New application data buffer of 4096 bytes allocated
ENCTCO_rad Application data begin is 30204942 4D4D4552 56413220 22546573
ENCTCO_cpt Inbound PDU trailer is 000581FF F7
ENCTSC_nth Converting inbound PDU segment FF81 to host format
ENCTCO_cpt Change direction trailer received

ENCTCO_rap Application Data PDU received

ENCTSO_dad PDU segment data begin -----*
ENCTSO_dad 000000 40000201 08000092 03050000 0C000192 * @.....Æ.....Æ *
:
:
ENCTSO_dad 000030 5E1601F2 E10B02B7 E756766F ACDE9AE3 * i.._β..ÄpVvoİÜð *
ENCTSO_dad PDU segment data end -----*

ENCTSO_pid Application data begin -----*
ENCTSO_pid 000000 30204942 4D4D4552 56413220 22546573 * 0 IBMMERVA2 "Tes *
:
:
ENCTSO_pid 0003F0 20393930 20393931 20393932 20393935 * 990 991 992 995 *
ENCTSO_pid Application data end -----*
ENCTSO_pid Application data successfully authenticated
ENCTSO_trm Service primitive completed at Mon Nov 03 11:44:41 1997

--CLIENT--> call outbound function for request "GETFUNCTIONLIST"
to server "MSERVER1 at XHRPC"

ENCTSO_srq Send request received at Mon Nov 03 11:44:44 1997

ENCTSO_pod Application data begin -----*
ENCTSO_pod 000000 47455446 554E4354 494F4E4C 495354 * GETFUNCTIONLIST *
ENCTSO_pod Application data end -----*

ENCTSO_gad PDU segment data begin -----*
ENCTSO_gad 000000 40000201 08000092 0F000000 0C000192 * @.....Æ.....Æ *
:
:
ENCTSO_gad 000030 297D3F83 0CC062E5 4142084E D37FF3F2 * )}?ã.ŁbŌAB.NĚΔ *
ENCTSO_gad PDU segment data end -----*
ENCTSC_htn Converting outbound PDU segment 0102 to network format
ENCTSC_htn Converting outbound PDU segment 81FF to network format
ENCTCO_sap Application Data PDU successfully sent

ENCTCO_rap Receive AD-PDU with a timeout of 3000 seconds
ENCTCO_rds Inbound PDU segment begin is 00400102 00089200 00001CB9 000C9201
ENCTSC_nth Converting inbound PDU segment 0201 to host format
ENCTCO_rad New application data buffer of 8192 bytes allocated
ENCTCO_rad Application data begin is 30202828 4D424352 43455252 20302022
ENCTCO_cpt Inbound PDU trailer is 000581FF F7
ENCTSC_nth Converting inbound PDU segment FF81 to host format
ENCTCO_cpt Change direction trailer received

ENCTCO_rap Application Data PDU received

ENCTSO_dad PDU segment data begin -----*

```

```

ENCTSO_dad 000000 40000201 08000092 B91C0000 0C000192 * @.....Æ¹.....Æ *
:
:
ENCTSO_dad 000030 D534AC6C 1614C8E9 8BB99835 0BDC44A3 * 141..ŁŪi¹y5K■Dú *
ENCTSO_dad PDU segment data end -----*

ENCTSO_pid Application data begin -----*
ENCTSO_pid 000000 30202828 4D424352 43455252 20302022 * 0 ((MBCRCERR 0 " *
:
:
ENCTSO_pid 0003F0 3E203E3D 203C3D20 3E203C20 3D292920 * > >= <= > < =) *
ENCTSO_pid Application data end -----*
ENCTSO_pid Application data successfully authenticated
ENCTSO_trm Service primitive completed at Mon Nov 03 11:44:46 1997

:
:
: (... further request data transfers between client and server ...)
:
:
:

--CLIENT--> call outbound function for request "DISCONNECT"
              to server "MSERVER1 at XHRPC"

ENCTSO_drq Disconnect request received at Mon Nov 11 17:27:13 1997
ENCTSC_htn Converting outbound PDU segment 81FF to network format
ENCTCO_drq Deallocate request successfully sent
ENCTCO_trm TCP/IP socket has been closed
ENCTSO_trm Service primitive completed at Mon Nov 11 17:27:13 1997
ENCTSO_trm Client process is about to terminate

ENCTSO      Process end          Mon Nov 11 17:27:13 1997
ENCTSO      Elapsed time is ... seconds

```

## Example of a Log File with Errors

The following section shows you a sample of records in a communications diagnosis log file displayed by a text editor.

The sample log file shows an error that occurs during the attempt at connection. The error is caused by the APPC communications tool. The local client communication component reports the error.

```

ENCTSO      MERVA Family Client process start on Tue Apr 22 08:54:19 1997

ENCTSO_crq Connect request parameters printed by ENCTSO_pcr:

ENCTSO_pcr Local client address is MCLIENT at XHRPC1
ENCTSO_pcr Local system type   is WNT
ENCTSO_pcr Processing trace lvl is 3

ENCTSO_pcr Server appl nickname is MESACICS
ENCTSO_pcr Server address      is ESASERV at XTRNODE
ENCTSO_pcr Msg processing table is TEST.AND.TRAINING
ENCTSO_pcr Server system type  is MVS/CICS
ENCTSO_pcr Appl data security  is Encryption 0 Authentication 0

ENCTSO_pcr Preferred conn type is SNA, CP timeout is 10 seconds
ENCTSO_pcr SNA APPC info      is TP 'DSLFL' at 'XTRESA'

ENCTSO_gcr PDU segment data begin -----*
ENCTSO_gcr 000000 6C000001 19000110 0A0001A1 58485250 * 1.....īXHRP *
:
:
:
ENCTSO_gcr 000060 BD25BB21 08000AA1 2D66D3FB * ½%ŋ!...ī-fĒ¹ *
ENCTSO_gcr PDU segment data end -----*

```

```

ENCTSO_lsp Loading DLL enctpo
ENCTSO_lsp DLL enctpo was successfully loaded

ENCTPO_alc Service Primitive    is CONNECT.Request
ENCTPO_alc Symbolic destination is XTRESA
ENCTPO_alc Partner TP name set  to DSLF
ENCTPO_alc Conv. security type  is PROGRAM

ENCTPO_alc Allocate conversation failed, CM_RC is decimal 2
ENCTSO_trm DTS error detected, TSO Error codes: RC = 81, RS = 8, EC = 0
ENCTSO_trm Application data security index is 0

ENCTSO_trm Error information type is 4, RC = 12, RS = 2, EC = 0
ENCTSO_trm > 004 Error reported by MFC DTS program ENCTPO:
ENCTSO_trm > 012 Allocate APPC conversation failed
ENCTSO_trm > 002 APPC allocate failure, retry recommended

ENCTSO_drq Disconnect request received at Tue Apr 22 08:54:20 1997
ENCTPO_drq Disconnect request ignored, conversation not allocated
ENCTSO_trm Service primitive completed at Tue Apr 22 08:54:20 1997
ENCTSO_trm Client process is about to terminate

ENCTSO      Process end          Tue Apr 22 08:54:20 1997
ENCTSO      Elapsed time is one second

```

---

## Logging Relationships

Several logging interdependencies are introduced to ensure that the causal connection of actions initiated by different components of the MERVA Message Processing Client and the related MERVA servers can be reproduced.

### Logging within the Components of the MERVA Message Processing Client

The following relationships are possible:

- If the client process requests data transfer services from the client communication component, it inserts a corresponding log entry in the **CC\_LOG**.
- If the client serving process requests data transfer services from the server communication component, it inserts a corresponding log entry in the **SC\_LOG**.

### MERVA Server Logs

Log entries in the log files of the MERVA server depend on the log level of the system. The following log entries are shown:

- The Client Serving Process requests services from the MERVA server.
- The requested services are executed by the MERVA server.

For details refer to the corresponding *MERVA Diagnosis Guide* of the MERVA server.

### Setting the Amount of Logging Data

You should change the level of logging only at the request of your IBM representative.

After the cause for a problem is found, reset the level of logging to its previous value that is determined in the installation part. For details refer to “Customizing Communication Systems for the MERVA Message Processing Client” on page 112.

---

## Problem Determination

This section tells you how to determine the cause of a problem. It describes the documentation that is required if you contact your IBM representative for further problem analysis.

If you have to submit an authorized program analysis report (APAR), follow the instructions of your IBM representative. An APAR contains a detailed description of the problem and problem-related data. Your IBM representative processes the APAR through IBM's Known Problems database.

### Initial Evaluation of a MERVA Message Processing Client Problem

If the MERVA Message Processing Client fails to function correctly, a diagnostic message is displayed. This message starts with **ENC**. For an explanation of each message and the action to take, refer to *Messages and Codes*. To access Messages and Codes, double-click the Messages and Codes icon in the MERVA Message Processing Client folder, or select it and press Enter.

If the same or a related problem occurs after you take the recommended action, repeat the initial evaluation of the problem. This helps you find out whether the problem is caused by an error in the code supplied by IBM, or by errors in the operating system or system services. Even if the problem occurs while the MERVA Message Processing Client is active, the problem might be caused by errors in the operating system or system services.

For the initial evaluation, take these steps:

1. Check whether the problem is software related or hardware related. For details see "Is the Problem Software Related or Hardware Related?"
2. If the problem is software related, classify type and component of the problem. For details see "Classifying a Software-Related Problem" on page 155.

#### **Is the Problem Software Related or Hardware Related?**

The first step to resolve a problem is to find out whether it is software related or hardware related. If you assume that the problem is hardware related, the following procedure helps you with the first step:

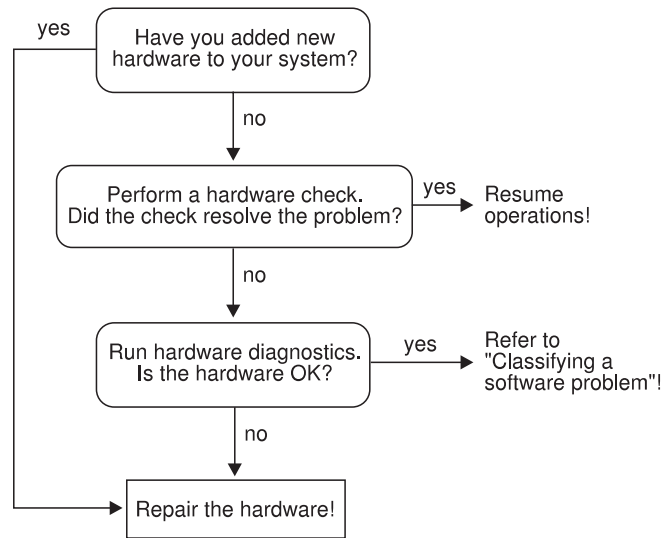

Figure 47. Problem Determination

### Classifying a Software-Related Problem

You classify a software-related problem by type and component. The type refers to the category of symptoms to which the problem belongs. The component refers to the operating system, the LAN software, the communication software, and the MERV Message Processing Client software that causes or reports the problem.

By classifying a problem by type and component and reporting this information to IBM, you can:

- Decrease the range of probable causes
- Accelerate the search within IBM's Known Problems database
- Accelerate the process of problem solving

### Identifying the Application or Scenario to Reproduce the Problem

By reproducing the problem, you get diagnostic information that helps you identify the source of the problem.

The following questions help you isolate the source of the problem, or identify the application or scenario to reproduce the problem:

1. How do you describe the problem?
  - Which are the tasks that you cannot perform?
  - Is the keyboard locked?
2. What happened when the problem occurred?
  - Were you working in a window of the operating system, in a session of the MERV Message Processing Client, or were you running a program from the MERV Message Processing Client folder?
  - Did the system stop when the problem occurred?
  - Which is the sequence of events and user actions that led to the problem?
  - Were the user actions carried out successfully before? If yes, were the circumstances different when the problem occurred?
  - Was the size of the failing application or scenario reduced to a minimum to eliminate extraneous symptoms?

- Were there messages or indications that a problem might occur? If yes, report message number and error codes. If there is no message number, report the message text.
  - Which is the last successfully run operation?
  - Which is the last displayed screen?
  - Were there other active programs on your workstation?
  - Is the problem a recurring problem?
  - Can you re-create the problem at will?
3. Are there unusual or specific operating circumstances?
- Is the application new?
  - Are the procedures new?
  - Might recent changes have affected the system?
  - Was the operating system or a service changed since the last time the application ran successfully?
  - Is there a recent installation of a ServicePak or a MERVA Message Processing Client PTF?

### Determining the Type of Software Problem

IBM ServiceLink and IBM Support Center databases have a structure for problem categories. This structure is shown in the following table:

*Table 6. Problem Categories*

| <b>Problem Keyword</b>       | <b>Problem Description</b>   |
|------------------------------|--|
| Installation (INSTALL)       | Problems caused by program changes, or experienced during or resulting from the installation of the MERVA Family Client program, applications, or new hardware.  |
| Abnormal termination (ABEND) | Abnormal termination refers to a recurring or unrecoverable problem caused by a program defect that unexpectedly ends processing by a component, application, or function.<br><br>An abnormal termination can result from a software compatibility problem or from problems associated with a workstation's hardware configuration.  |
| Wait or Loop (WAIT/LOOP)     | If your keyboard is locked, or if the program is not responding as it should, an unexpected program suspension, referred to as a wait, might have occurred.<br><br>If a program encounters a problem or contains a coding error that causes it to execute a certain sequence of instructions repeatedly while the error conditions persists, an uncontrollable program loop might have occurred.<br><br>Based on external symptoms, you might not be able to distinguish between a wait and a loop. For this reason, these two types are grouped together. |

Table 6. Problem Categories (continued)

| Problem Keyword               | Problem Description   |
|-------------------------------|---|
| Performance problems (PERFM)  | <p>This refers to unusually slow or delayed system run or response time that causes programs to take longer than usual to complete a task. Performance problems can be caused, for example, by a shortage of disk space, improper allocation of buffers, and program resources of the operating system.</p> <p>Many performance problems can be solved by means of system tuning. Check the configuration settings to ensure that they are appropriate for the number of applications and files that currently run on your system.</p> <p>A performance problem can also result from a software compatibility problem or from problems associated with the hardware configuration of a workstation.</p> |
| Deficient documentation (DOC) | <p>If the product documentation is deficient, for example, if helps or procedures are incomplete or incorrect, report the problem in detail to IBM.</p> <p>Include title, form number, and the page number of the page on which the error occurs. If you report an error in the online documentation, include title or name of the online help panel.</p>   |
| Incorrect output (INCORROUT)  | <p>This refers to the following situations:</p> <ul style="list-style-type: none"> <li>• Output is missing.</li> <li>• Output is incorrect.</li> <li>• Data returned by the program is missing or incorrect.</li> </ul>   |

**Note:** External symptoms might belong to more than one problem type. In this case, review each description to determine the best match.

### Determining the Component Associated with the Problem

Use the following descriptions to determine the component that has or causes the problem:

#### Operating system

Operating system problems include problems that occur when you respond to operating system prompts or when you use a text editor, the file system, or the print spooler.

#### Communication Services

Because the MERVA Message Processing Client is installed in a remote configuration by means of communication services, such as Personal Communications, you might get communication problems.

For more information refer to the supported communication software documentation.

#### The MERVA Message Processing Client

Problems regarding the MERVA Message Processing Client include problems that occur when you use the client executable or the installation and customization programs.

### Operating System Problems

Read this section if you assume that an operating system problem exists. Operating problems are, for example:

- Installation Problems (INSTALL)

If you assume that an installation problem is connected to the operating system, take these steps:

1. Try to reproduce the problem.
2. Review the information in the installation log.
3. Reinstall the program with the original distribution media. Do not change any file or add other software. If the operation runs successfully, the problem is solved. If the operation does not run successfully, take the next step.
4. Remove any non-IBM or non-supported IBM hardware and retry the failing operation. If the software problem is solved, the installation problem is connected to the interaction between hardware and software. Refer to the information that is supplied with the hardware to solve the hardware problem.

- Abnormal termination (ABEND)

Indications of an abnormal termination are, for example:

- An unexpected return to the desktop of the operating system or to the command prompt
- A message that the system is stopped unexpectedly
- A postmortem error message that indicates a general protection fault

Postmortem dumps are generated when the base operating system or the hardware ends an application because the application violates one of the rules maintained by the base operating system or the hardware. Possible reasons are:

- An application tries to access storage that the application is not allowed to access.
- The processor tries to run a privileged or inexecutable instruction.

Record the data of the error to compare it with the system error message. Examine it then for additional information or instructions.

- Wait or loop (WAIT/LOOP)

An application can be blocked, in an apparently irrecoverable wait state, or in a loop. If a blocking or wait state occurs, a wait condition might exist. In this case, take these steps:

1. Try to isolate the problem to a single application. If you can isolate the problem to a specific application, solve the problem by using the information supplied with the respective application.
2. Try to isolate the problem to the set of concurrent applications or to the circumstances that cause the wait condition.
3. Write down the steps that lead to the failure.

If you assume that a loop involving the base operating system occurs, try to isolate the application involved. If you can isolate the problem to a specific application, solve the problem by using the information supplied with the respective application.

- Performance problems (PERFM)

These are, for example:

- Software incompatibility
- Program components of an operating system or an application that can affect other program components of an operating system or an application.

In case of performance problems, the following problems can occur:

- Slow system processing or response time causes the programs to take longer than usual to complete a task.



- Program suspension when you switch from one session to another.
- Incorrect or incomplete program processing that might result in incorrect output.
- Program or system failure that might result in abnormal termination.

Try to reproduce the problem on a system with the same configuration and memory size. If you cannot reproduce the problem on this system, the problem might be a hardware problem.

### **MERVA Message Processing Client Problems**

For all types of MERVA Message Processing Client problems, the following information is required:

- Workstation model, main memory size, hard disk size
- Version, release, and service level (CSD) of the operating system
- Version, release, and service level (CSD) of the communication tool
- Version, release, and PTF level of the MERVA Message Processing Client
- Component identification of the MERVA Message Processing Client

The following information about MERVA Client trace and configuration is also necessary for problem tracking:

- Installation and configuration report

To generate this report, run the **enccfg.exe**. It is contained in the installation directory of the MERVA Client. By default, the output is sent to the screen. To sent the output to a file, use the redirect operator >.

- Client diagnosis logs on client (CP\_LOG) and server (CP\_LOG)

For details on how to change trace settings, refer to “Changing Settings” on page 10. For information about naming conventions and locations of the logs, refer to Table 4 on page 144.

- Communication diagnosis logs on client (CC\_LOG) and server (SC\_LOG)

For details on trace customization, refer to “Customizing Communication Systems for the MERVA Message Processing Client” on page 112 and “DTS Profile Contents (MFCL Client)” on page 131. For information about naming conventions and locations of the logs, refer to Table 4 on page 144.



---

## Appendix C. Notices

This information was developed for products and services offered in the U.S.A. IBM may not offer the products, services, or features discussed in this document in other countries. Consult your local IBM representative for information on the products and services currently available in your area. Any reference to an IBM product, program, or service is not intended to state or imply that only that IBM product, program, or service may be used. Any functionally equivalent product, program, or service that does not infringe any IBM intellectual property right may be used instead. However, it is the user's responsibility to evaluate and verify the operation of any non-IBM product, program, or service.

IBM may have patents or pending patent applications covering subject matter described in this document. The furnishing of this document does not give you any license to these patents. You can send license inquiries, in writing, to:

IBM Director of Licensing  
IBM Corporation  
North Castle Drive  
Armonk, NY 10504-1785  
U.S.A.

For license inquiries regarding double-byte (DBCS) information, contact the IBM Intellectual Property Department in your country or send inquiries, in writing, to:

IBM World Trade Asia Corporation  
Licensing  
2-31 Roppongi 3-chome, Minato-ku  
Tokyo 106, Japan

**The following paragraph does not apply to the United Kingdom or any other country where such provisions are inconsistent with local law:**

INTERNATIONAL BUSINESS MACHINES CORPORATION PROVIDES THIS PUBLICATION "AS IS" WITHOUT WARRANTY OF ANY KIND, EITHER EXPRESS OR IMPLIED, INCLUDING, BUT NOT LIMITED TO, THE IMPLIED WARRANTIES OF NON-INFRINGEMENT, MERCHANTABILITY OR FITNESS FOR A PARTICULAR PURPOSE. Some states do not allow disclaimer of express or implied warranties in certain transactions, therefore, this statement may not apply to you.

This information could include technical inaccuracies or typographical errors. Changes are periodically made to the information herein; these changes will be incorporated in new editions of the publication. IBM may make improvements and/or changes in the product(s) and/or the program(s) described in this publication at any time without notice.

Licensees of this program who wish to have information about it for the purpose of enabling: (i) the exchange of information between independently created programs and other programs (including this one) and (ii) the mutual use of the information which has been exchanged, should contact:

IBM Deutschland  
Informationssysteme GmbH  
Department 3982  
Pascalstrasse 100

70569 Stuttgart  
Germany

Such information may be available, subject to appropriate terms and conditions, including in some cases, payment of a fee.

The licensed program described in this information and all licensed material available for it are provided by IBM under terms of the IBM Customer Agreement or any equivalent agreement between us.

The following paragraph does apply to the US only.

All IBM prices shown are IBM's suggested retail prices, are current and are subject to change without notice. Dealer prices may vary.

This information is for planning purposes only. The information herein is subject to change before the products described become available.

#### COPYRIGHT LICENSE:

This information contains sample application programs in source language, which illustrates programming techniques on various operating platforms. You may copy, modify, and distribute these sample programs in any form without payment to IBM, for the purposes of developing, using, marketing or distributing application programs conforming to the application programming interface for the operating platform for which the sample programs are written. These examples have not been thoroughly tested under all conditions. IBM, therefore, cannot guarantee or imply reliability, serviceability, or function of these programs. You may copy, modify, and distribute these sample programs in any form without payment to IBM for the purposes of developing, using, marketing, or distributing application programs conforming to IBM's application programming interfaces.

---

## Trademarks

The following terms are trademarks of the IBM Corporation in the United States or other countries, or both:

CICS  
CICS/ESA  
CICS/VSE  
eNetwork  
IBM  
IMS  
IMS/ESA  
MVS  
MVS/CICS  
MVS/ESA  
VSE/ESA

AccordWorkstation (AWS) and Directory Services Application (DSA) are trademarks of S.W.I.F.T., La Hulpe in Belgium.

Pentium is a trademark of Intel Corporation.

Java and all Java-based trademarks and logos are trademarks of Sun Microsystems, Inc. in the United States, other countries, or both.

Microsoft, Windows, Windows NT, and the Windows logo are trademarks of Microsoft Corporation in the United States, other countries, or both.

Other company, product, and service names may be trademarks or service marks of others.



---

## Glossary

### A

**address.** See *S.W.I.F.T. address*.

**address expansion.** The process by which the full name of a financial institution is obtained using the S.W.I.F.T. address, telex correspondent's address, or a nickname.

**answerback.** In telex, the response from the dialed correspondent to the "WHO R U" signal.

**answerback code.** A group of up to 6 letters following or contained in the answerback to check the answerback.

**APC.** Application Control.

**application.** See *message application*.

**API.** Application Programming Interface.

**APPC.** Advanced Program-to-Program Communication.

**Application Programming Interface (API).** Application Programming Interface.

**Application Support (AS).** Application Support.

**ASCII.** American Standard Code for Information Interchange.

**authentication.** The S.W.I.F.T. security check to ensure that a message is not changed during transmission and that a message is sent by an authorized sender.

**authorization.** The process of granting you complete or restricted access to the functions of the MERVA Message Processing Client.

### B

**Bank Identifier Code (BIC).** The S.W.I.F.T. address of a bank as assigned by S.W.I.F.T. See also *S.W.I.F.T. address*.

**BIC.** Bank Identifier Code. See also *S.W.I.F.T. address*.

**body.** See *message body*.

### C

**category.** See *message category*.

**CBT.** S.W.I.F.T. Computer-Based Terminal.

**CC\_Log.** The communication diagnosis log file that contains information about the client communication.

**component.** A functionally distinct part of MERVA, such as MERVA Link.

**correspondent.** An institution to which your institution sends messages and from which messages are received.

**correspondent identifier.** The 11-character identifier of the receiver of a telex message. Used as a key to retrieve information from the Telex Correspondents File.

**CP\_Log.** The communication diagnosis log file that contains information about the client process.

**cross-field checking.** When you move to a new field in a message, MERVA checks that the data that is entered in the previous field is correct. Some fields depend on entries that are made in other fields.

**CSP\_Log.** The communication diagnosis log file that contains information about the client serving process.

**Currency Code File.** The file that contains the currency codes together with the name, fractional part country code, and country names.

### D

**data area.** An area in a message-processing window of a predefined length and format, where you can enter or display data. A field can consist of one or more data areas.

### F

**field.** An area used to enter or display a particular type of data in a predefined format. A subdivision of a message. A field is located by its position in a message and by its tag. A field is made up of one or more data areas. See also *data area*.

**FIN.** Financial Application.

**four-eyes principle.** A banking security concept whereby changes and approval of changes must always be carried out by two different people.

### I

**icon.** A pictorial representation of an object or a selection choice. An icon also represents an application when it is minimized.

**input message.** A message that is sent to the S.W.I.F.T. network.

**ISO.** International Organization for Standardization.

## L

**LT or LTERM.** Logical terminal. A destination with a name related to one or more physical terminals.

## M

**MERVA ESA.** Message Entry and Routing with Interfaces to Various Applications for ESA.

**MERVA Link.** The MERVA component that can interconnect MERVA systems.

**MERVA-related data.** A representation of data that MERVA uses while processing the message. This data is not included in the message body and is only used by MERVA.

**MERVA USE & Branch for Windows NT.** Message Entry and Routing with Interfaces to Various Applications USE & Branch for Windows NT.

**MERVA USE & Branch for Windows NT with SWIFT Link.** Message Entry and Routing with Interfaces to Various Applications USE & Branch for Windows NT with SWIFT Link.

**message.** A string of fields in a predefined form to send or receive information.

**message application.** A specification for an application area to which message categories and messages belong.

**message body.** The part of the message that contains the message text. This text contains the data that is sent to other MERVA systems, non-MERVA applications, and networks.

**message category.** A group of messages that are logically related within an application.

**message database.** An area to store messages that are created by using the MERVA Message Processing Client or messages that are received from other systems.

**message header.** The leading part of a message that contains the sender and receiver of the message, the message priority, and the type of message.

**message-processing function.** The various parts of the MERVA Message Processing Client to create, verify, authorize, edit, display, print, and delete messages.

**message queue.** A logical subdivision of the message database to store messages, on a first-in, first-out basis while the messages wait to be processed by a

message-processing function. The queue has the same name as the message-processing function with which it is associated.

**message reference number (MRN).** A unique 16-digit number assigned to each message for identification purposes. The message reference number consists of an 8-digit domain identifier followed by an 8-digit sequence number.

**message sequence number (MSN).** A sequence number for messages that are transferred by MERVA Link.

**message template.** An outline to create similar messages of this type. See also *S.W.I.F.T. message*.

**message type (MT).** A number up to 8 characters long that identifies a message. S.W.I.F.T. messages are identified by a 3-digit number, for example, S.W.I.F.T. message type MT 100.

**MRN.** Message Reference Number.

**MSN.** Message Sequence Number.

**MTP.** Message Transfer Process or Program.

**MT.** Message Type.

## N

**nested message.** A message that is composed of one or more message types.

**network.** A link between two or more computer locations.

**nickname.** An abbreviation or synonym of the Bank Identifier Code (BIC) of a financial institution with which you correspond frequently.

## O

**occurrence.** See *repeatable sequence*.

## P

**PTF.** Program Temporary Fix.

**PTN.** Public Telex Network.

## Q

**queue.** See *message queue*.

## R

**ready-to-send queue.** A queue to collect messages that are ready to be sent to S.W.I.F.T. or telex network.



**repeatable sequence.** A field or group of fields that can be successively entered or displayed more than once in a message.

**retype verification.** See *verification*.

**routing.** The passing of messages from one processing stage in a predefined processing path to the next processing stage.

## S

**SC\_Log.** The communication diagnosis log file that contains information about the server communication.

**sign off.** To end a session with the MERVA Message Processing Client.

**sign on.** To start a session with the MERVA Message Processing Client.

**SNA.** Systems Network Architecture.

**subfield.** A subdivision of a field with a specific meaning. For example, field 52A consists of Account Number and Logical Terminal subfields.

**S.W.I.F.T.** Society for Worldwide Interbank Financial Telecommunication, s.c.

**S.W.I.F.T.** Refers to the S.W.I.F.T. network of the Society for Worldwide Interbank Financial Telecommunication, s.c. (S.W.I.F.T.).

**S.W.I.F.T. address.** A bank identifier code (BIC) that consists of 12 characters to identify a bank within the S.W.I.F.T. network. The code is assigned by S.W.I.F.T. and has the following subcodes:

- Bank code (4 characters)
- ISO country code (2 characters)
- Location code (2 characters)
- LT code (1 character)
- Branch code (3 characters) for a S.W.I.F.T. user institution

**S.W.I.F.T. Correspondents File.** The file that contains the S.W.I.F.T. address or BIC, together with the name, postal address, and zip code of each financial institution in the BIC directory.

**S.W.I.F.T. financial message.** A message in one of the S.W.I.F.T. categories 1 to 9 that you can send or receive via the S.W.I.F.T. network.

**S.W.I.F.T. message.** A message in one of the S.W.I.F.T. categories as defined in the *S.W.I.F.T. User Handbook* that you can send or receive via the S.W.I.F.T. network.

**S.W.I.F.T. system message.** A S.W.I.F.T. general purpose application (GPA) message or a financial application (FIN) message in S.W.I.F.T. category 0.

**Systems Network Architecture (SNA).** The description of the logical structure, formats, protocols, and operating sequences for transmitting information units through, and controlling the configuration and operation of, networks.

## T

**TCP/IP.** Transmission Control Protocol/Internet Protocol.

**Telex Link.** The MERVA system component to link the public telex network.

**telex header.** The first part of a telex message with control information for the telex network.

**template.** See *message template*.

**testkey.** Normal banking practice requires the addition of a testkey to a telex message to ensure message integrity and authorized delivery. The testkey is an integer value of up to 16 digits, calculated using the significant information in the message, for example, amounts, currency codes, and message date. The testkey is calculated manually or by a testkey-processing program.

**Transmission Control Protocol/Internet Protocol (TCP/IP).** A set of communication protocols that support peer-to-peer connectivity functions for local and wide area networks.

**TRN.** Transaction Reference Number.

## U

**UPM.** User Profile Management.

**user profile.** A description of a user that includes such information as user ID, user name, user password, access authority, and other attributes obtained at logon. It contains also specifications of the functions that a user is allowed to perform and the associated queues. The user profile can only be maintained by authorized users.

**User Profile Management.** A component that provides user ID validation, and user and group management facilities. Each installation of User Profile Management is local to the particular workstation where it is installed and validates user accessing controlled data or using programs that reside on that particular workstation. It also provides the mechanism for users to log on to the system and log off from the system, and to identify and authenticate system users.

## V

**verification.** A check by reading through the message or retyping marked fields to ensure that the contents of a message are correct.

## W

**Who Are You (WRU).** Answerback that identifies the remote subscriber.

---

## Bibliography

This bibliography lists all publications in the MERVAs library other than this book, related IBM publications, and non-IBM publications that might be useful for reference purposes.

With exception of the General Information and the Licensed Program Specifications, all MERVAs books are available as softcopy on the

- *MERVA Documentation CD*, SK2T-9752

- *MERVA ESA V4 Customization Guide*, SH12-6380
- *MERVA ESA V4 Concepts and Components*, SH12-6381
- *MERVA ESA V4 Diagnosis Guide*, SH12-6382
- *MERVA ESA V4 Advanced MERVA Link*, SH12-6390
- *MERVA ESA V4 System Programming Guide*, SH12-6366

---

## IBM MERVAs Publications

### MERVA ESA Components Books

- *MERVA ESA Components Licensed Program Specifications*, GH12-6333
- *MERVA USE & Branch for Windows NT User's Guide*, SH12-6334
- *MERVA USE & Branch for Windows NT Installation and Customization Guide*, SH12-6335
- *MERVA USE & Branch for Windows NT Application Programming Guide*, SH12-6336
- *MERVA USE & Branch for Windows NT Diagnosis Guide*, SH12-6337
- *MERVA USE & Branch for Windows NT Migration Guide*, SH12-6393
- *MERVA USE Administration Guide*, SH12-6338
- *MERVA Connection/NT*, SH12-6339
- *MERVA Connection/400*, SH12-6340
- *MERVA Message Processing Client for Windows NT User's Guide*, SH12-6341
- *MERVA Automatic Message Import/Export Facility User's Guide*, SH12-6389
- *MERVA Workstation Based Functions*, SH12-6383

### MERVA ESA Books

- *MERVA ESA V4 Licensed Program Specifications*, GH12-6373
- *MERVA ESA V4 Application Programming Interface*, SH12-6374
- *MERVA ESA V4 Operations Guide*, SH12-6375
- *MERVA ESA V4 User's Guide*, SH12-6376
- *MERVA ESA V4 Macro Reference*, SH12-6377
- *MERVA ESA V4 Installation Guide*, SH12-6378
- *MERVA ESA V4 Messages and Codes*, SH12-6379

---

## S.W.I.F.T. Publications

The following books are published by the Society for Worldwide Interbank Financial Telecommunication, s.c., in La Hulpe, Belgium:

- *S.W.I.F.T. User Handbook*
- *S.W.I.F.T. Dictionary*
- *S.W.I.F.T. Directory*
- *S.W.I.F.T. FIN Security Guide*
- *S.W.I.F.T. Card Readers User Guide*
- *S.W.I.F.T. Security Features Technical*



---

# Index

## A

- accelerator key, definition 14
- Accept 48
- Accept with parameters 49
- actions for message processing
  - Accept 48
  - Accept with parameters 49
  - Check 49
  - Close 49
  - Copy to print 49
  - Delete 49
  - Delete by routing 50
  - Move 50
  - Print 50
  - Reject 50
  - Replace 50
  - Requeue 50
  - Route to edit queue 50
  - Route to telex queue 50
  - Save 50
  - Save as template 50
- authentication checking 35
- authorize 69
- Authorize Message window
  - action button 72
  - description 70
  - layout 69
  - menu items
    - Edit 71
    - Envelopes 71
    - Help 71
    - Message 71
    - View 71
  - window button 72
- authorizing
  - messages 69
  - telexes 72

## C

- calculating testkeys 88
- changing
  - color 13
  - password 9
  - setting 10
- Check 49
- checking errors 37, 49
- Checking Errors window 37, 49
- client, log files 143
- clipboard, handling 36
- Close 49
- color, changing 13
- concept of messages
  - message application 4
  - message category 4
  - message typ 5
- Copy to print 49
- Create Message window
  - action button 59

- Create Message window (*continued*)
  - data
    - copying 57, 67
    - cutting 57, 67
    - deleting 57
    - displaying 57
    - inserting 57
    - pasting 57, 67
  - layout 55
  - menu items
    - Edit 57
    - Envelopes 58
    - Help 58
    - Message 57
    - View 57
  - window button 59
- creating
  - free format messages 96
  - messages 51
  - telexes 85
- creating a S.W.I.F.T. message for telex transmission 60
- cross-field error checking 37
- customization of DC systems for the Merva Message Processing Client
  - SNA customization for a Merva Server on ESA 116
  - SNA customization for a Merva Server on Windows NT 114
  - TCP/IP customization for a Merva Server on ESA 116
  - TCP/IP customization for a Merva Server on Windows NT 115
- customization of the Merva Client Data Transfer Service
  - DTS DS database contents (client) 131
  - DTS DS database contents (server) 135
  - DTS DS database implementation 137
  - DTS DS database structure 116
  - Merva Client and Merva Server
    - DTS DS DB structure 130
  - Merva Client DTS DS DB structure 127
  - Merva Client DTS sample configuration 137
  - Merva Server DTS DS DB structure 129

## D

- data, how to enter in S.W.I.F.T. messages 33
- Delete 49
- Delete by routing 50
- deleting templates 104
- determining problems
  - hardware problems 154

- determining problems (*continued*)
  - Merva Message Processing Client
    - problems 154, 159
    - operating system problems 157
    - software problems 155, 156
  - diagnosing problems
    - exception messages 146
    - log files, overview 143
    - trace messages 147
  - dispatch function
    - calculating testkeys 88
    - routing messages to the telex network 92
    - routing NAKed telex messages 89
    - verifying testkeys 91
  - display 79
  - Display Message window
    - layout 79
    - menu items
      - Edit 81
      - Envelopes 81
      - Help 81
      - Message 81
      - View 81
    - window button 82
  - Display Templates window 99
    - layout 99
    - menu items
      - Edit 100
      - Envelopes 100
      - Help 100
      - Message 100
      - View 100
    - window button 101
  - displaying
    - messages 79
    - templates 99
  - displaying only fields with data 37

## E

- edit 73
- Edit Message window
  - action button 76
  - description 74
  - layout 73
  - menu items
    - Edit 75
    - Envelopes 76
    - Help 76
    - Message 75
    - View 75
  - window button 77
- Edit Templates window 101
  - layout 101
  - menu items
    - Edit 103
    - Envelope 103
    - Help 103
    - Message 102
    - View 103
  - window button 104

- editing
  - messages 73
  - telexes 77
  - templates 101
- entering data in messages 33
- envelopes view 46
- error checking 37, 49
- example of message processing 15
- exception message 146

## F

- field types of messages
  - mandatory field 33
  - occurrence 33
  - repeatable sequence 33
  - sequence 33
  - subfield 33
- filter for function lists 25
- find parameters, how to specify 22
- Find Text window 40
- finding text in text view mode 40
- Function List window
  - action button 26
  - description 21
  - Description list 23
  - function list, main window area 25
  - functions
    - closing 24
    - minimizing 24
    - refreshing information 24
    - restoring 24
    - selecting 25
    - sorting 24
  - layout 21
  - menu items
    - Help 24
    - Selected 22
    - User 22
    - View 24
    - Window 24
  - window button 26
  - window part 21
- functions
  - closing 24
  - minimizing 24
  - refreshing information 24
  - restoring 24
  - selecting 25
  - sorting 24

## G

- general telex information 95

## H

- help
  - accelerator key, definition 14
  - how to get 14
  - types 14

## I

- installation
  - corrective service 111

- installation (*continued*)
  - general description 110
  - hardware requirements 109
  - software requirements 109
  - steps 111
  - verification 111
- installing the MERVA Message Processing Client 109

## L

- log files
  - client 143
  - examples of 149
  - server 153
- logging data, amount 153

## M

- Maintain Templates window
  - description 97
  - layout 97
  - menu items 98
  - window button 98
- mandatory field 33
- MERVA Message Processing Client
  - introduction 3
  - overview 3
  - starting 7
  - stopping 15
  - stopping abnormally 22
- MERVA-related data 5, 41
- message
  - authorizing 68
  - Create Message window 55
  - creating 51, 55
  - displaying 77
  - editing 72
  - entering data 33
  - error checking 37, 49
  - field types
    - mandatory field 33
    - occurrence 33
    - repeatable sequence 33
    - sequence 33
    - subfield 33
  - locating 22
  - new message, creating 53, 55
  - parts 5
  - printing 83
  - retyping 65
- message body in text view 37
- message groups 4
- Message List window
  - action button 31
  - description 27
  - layout 27
  - menu items
    - Help 29
    - Selected 28
    - View 29
    - Window 29
  - message list
    - closing 29
    - minimizing 29
    - refreshing information 29
    - restoring 29

- Message List window (*continued*)
  - message list (*continued*)
    - selecting 29
    - sorting 29
  - message list, main window area 30
  - window button 31
  - window part 27
- message part
  - MERVA-related data 5
  - message body 5
  - message envelopes 6
  - structure 33
- message processing
  - example 15
  - tasks 3
- message-processing actions
  - Accept 48
  - Accept with parameters 49
  - Check 49
  - Close 49
  - Copy to print 49
  - Delete 49
  - Delete by routing 50
  - Move 50
  - Print 50
  - Reject 50
  - Replace 50
  - Requeue 50
  - Route to edit 50
  - Route to telex queue 50
  - Save 50
  - Save as template 50
- message type, selecting 53
- Move 50

## O

- occurrence 33
- overview of MERVA Message Processing Client 3

## P

- password
  - changing 9
  - synchronizing 9
- print 83
- Print 50
- printing
  - messages 83
  - working copy 84
- problem, diagnosing 143
- problem determination 153
- Prompt Codeword window 35
- Prompt Correspondent window 35

## R

- Reject 50
- repeatable sequence 33
- Replace 50
- Requeue 50
- retype 65
- Retype Message window
  - action button 68
  - description 66
  - menu items
    - Edit 67

Retype Message window (*continued*)  
  Envelopes 68  
  Help 68  
  Message 67  
  View 67  
  window button 68  
retyping  
  messages 65  
  telexes 68  
Route to edit queue 50  
Route to telex queue 50  
routing messages to the telex  
  network 92  
routing NAKed telex messages 89

## S

Save 50  
Save as template 50  
Select Message Type window 53  
  action button 54  
  layout 53  
  window button 54  
  window field 54  
Select Print Queue window 83  
Select Template window  
  action button 60  
  layout 59  
  window button 60  
  window field 59  
selecting a message type 53  
selecting templates  
  for maintenance 97  
  for message creation 59  
sequence 33  
server, log files 153  
settings, changing 10  
signing off from MERVA Message  
  Processing Client 15  
signing on to MERVA Message Processing  
  Client 7  
Specify Find Parameters window 22  
Specify Template Name and Description  
  window 50  
specifying template name and  
  description 50  
specifying wildcards 23  
starting MERVA Message Processing  
  Client  
  password 7  
  user ID 7  
startup options 8  
stopping MERVA Message Processing  
  Client 15  
subfield 33  
synchronizing password 9

## T

telex  
  authorizing 72  
  creating 85  
  creating a S.W.I.F.T. message for telex  
    transmission 60  
  editing 77  
  printing telex envelopes 83  
  retyping 68

telex envelope  
  telex header 86  
  testkey fields 87  
telex header  
  creating 86  
  description 93  
telex information, general 95  
template  
  deleting 104  
  Display Templates window 99  
  displaying 99  
  Edit Templates window 101  
  editing 101  
  Maintain Templates window 97  
  maintaining 97  
  Select Template window 59  
  selecting for maintenance 97  
  selecting for message creation 60  
  specifying name and description 50  
  using for message creation 59  
testkey fields  
  creating 87  
  description 94  
testkeys  
  calculating 88  
  description 94  
text view of message body 37  
trace message 147

## V

verifying testkeys 91

## W

wildcard, specifying 23





---

## Readers' Comments — We'd Like to Hear from You

MERVA ESA Components  
MERVA Message Processing Client for Windows NT User's Guide  
Version 4 Release 1

Publication No. SH12-6341-01

Overall, how satisfied are you with the information in this book?

|                      | Very Satisfied           | Satisfied                | Neutral                  | Dissatisfied             | Very Dissatisfied        |
|----------------------|--------------------------|--------------------------|--------------------------|--------------------------|--------------------------|
| Overall satisfaction | <input type="checkbox"/> | <input type="checkbox"/> | <input type="checkbox"/> | <input type="checkbox"/> | <input type="checkbox"/> |

How satisfied are you that the information in this book is:

|                          | Very Satisfied           | Satisfied                | Neutral                  | Dissatisfied             | Very Dissatisfied        |
|--------------------------|--------------------------|--------------------------|--------------------------|--------------------------|--------------------------|
| Accurate                 | <input type="checkbox"/> | <input type="checkbox"/> | <input type="checkbox"/> | <input type="checkbox"/> | <input type="checkbox"/> |
| Complete                 | <input type="checkbox"/> | <input type="checkbox"/> | <input type="checkbox"/> | <input type="checkbox"/> | <input type="checkbox"/> |
| Easy to find             | <input type="checkbox"/> | <input type="checkbox"/> | <input type="checkbox"/> | <input type="checkbox"/> | <input type="checkbox"/> |
| Easy to understand       | <input type="checkbox"/> | <input type="checkbox"/> | <input type="checkbox"/> | <input type="checkbox"/> | <input type="checkbox"/> |
| Well organized           | <input type="checkbox"/> | <input type="checkbox"/> | <input type="checkbox"/> | <input type="checkbox"/> | <input type="checkbox"/> |
| Applicable to your tasks | <input type="checkbox"/> | <input type="checkbox"/> | <input type="checkbox"/> | <input type="checkbox"/> | <input type="checkbox"/> |

Please tell us how we can improve this book:

Thank you for your responses. May we contact you?  Yes  No

When you send comments to IBM, you grant IBM a nonexclusive right to use or distribute your comments in any way it believes appropriate without incurring any obligation to you.

---

Name

---

Address

---

Company or Organization

---

Phone No.



Fold and Tape

**Please do not staple**

Fold and Tape

PLACE  
POSTAGE  
STAMP  
HERE

IBM Deutschland Entwicklung GmbH  
Information Development & User Centered Design  
Dept. 0446  
Schoenaicher Strasse 220  
71032 Boeblingen  
Germany

Fold and Tape

**Please do not staple**

Fold and Tape





Program Number: 5648-B30

Printed in Denmark by IBM Danmark A/S



Java and all Java-based trademarks and logos are trademarks of Sun Microsystems, Inc. in the United States and other countries.

SH12-6341-01

