

IBM Network Printer 17



Quick Setup

IBM Network Printer 17



Quick Setup

Note!

Before using this information and the product it supports, be sure to read the general information under "Notices" on page 26.

Second Edition (November 1996)

This manual obsoletes G544-5346-00.

The following paragraph does not apply to any other country where such provisions are inconsistent with local law.

INTERNATIONAL BUSINESS MACHINES CORPORATION PROVIDES THIS PUBLICATION "AS IS" WITHOUT WARRANTY OF ANY KIND, EITHER EXPRESS OR IMPLIED, INCLUDING, BUT NOT LIMITED TO THE IMPLIED WARRANTIES OF MERCHANTABILITY OR FITNESS FOR A PARTICULAR PURPOSE. Some states do not allow disclaimer of express or implied warranties in certain transactions, therefore, this statement may not apply to you.

Changes are made periodically to this publication.

Requests for IBM publications should be made to your IBM representative or to the IBM branch office serving your locality. If you request publications from the address given below, your order will be delayed, because publications are not stocked there.

A Reader's Comment Form is provided at the back of this publication. You may also send comments by fax to 1-800-524-1519, by e-mail to print_pubs@vnet.ibm.com, or by regular mail to:

Department H7FE Building 003G
IBM Printing Systems Company
Information Development
PO Box 1900
Boulder CO USA 80301-9191

IBM may use or distribute whatever information you supply in any way it believes appropriate without incurring any obligation to you.

© **Copyright International Business Machines Corporation 1996. All rights reserved.**

Note to U.S. Government Users — Documentation related to restricted rights — Use, duplication or disclosure is subject to restrictions set forth in GSA ADP Schedule Contract with IBM Corp.

Contents

Start Here	1
Printer Dimensions	1
Standard Features	1
Installing Other Options and Attachments	2
Unpacking the Printer	3
Installing the Toner Cartridge	4
Loading Paper	8
Applying the Operator Panel Template	12
Powering On the Printer	14
Selecting a Language	17
Printing the Printer Configuration Page	20
Connecting the Parallel Cable	22
Installing Printer Drivers	24
What To Do Next	25
Notices	26
Trademarks	26

Start Here

This booklet describes how to set up your Network Printer 17. It describes a basic configuration using a parallel cable connection. This cable needs to be purchased separately; it is not included with the printer.

Note: In addition to the parallel cable attachment, the Network Printer 17 supports a wide variety of network attachment interfaces, including twinax, coax, token ring, and Ethernet attachments. For information about installing network attachments and other optional features, please read "Installing Other Options and Attachments" on page 2.

Printer Dimensions

Before you install your printer, make sure you have a place large enough to put it. Without any of its optional features attached, the printer dimensions are:

Width	17.5 inches (442 mm)
Depth	16.5 inches (418 mm)
Height	12 inches (294 mm)

In addition, make sure you leave enough room around the printer to access and operate it. IBM recommends leaving at least 18 inches (450 mm) in the back of the printer, 24 inches (600 mm) in the front of the printer, and 8 inches (200 mm) on each side.

Standard Features

Standard features of the printer include:

- Printing speed of up to 17 pages per minute
- Resolution of 600 dots per inch (dpi)
- PCL5e support
- 4MB of memory
- Parallel interface (IEEE 1284)
- 250-sheet paper tray
- 100-sheet auxiliary tray
- 250-sheet paper output bin
- Printer drivers

Installing Other Options and Attachments

IBM recommends that you follow the instructions in this book to install the base printer before you install any of its optional features and attachments. This helps make it easier to resolve installation problems, should they occur. For information on how to install any of the following optional features, see the *IBM Network Printer 17: User's Guide*:

- Up to two additional 500-sheet paper trays
- 500-sheet Offset Paper Output Bin
- Duplex Unit
- Envelope feeder with a capacity of 75 envelopes
- 10-bin mailbox
- 4MB, 8MB, 16MB, and 32MB Memory SIMMs
- Adobe PostScript Level 2 SIMM
- IBM IPDS SIMM
- 810MB Hard Drive
- Flash Memory SIMM (2MB, 4MB)
- Attachment cards:
 - IBM Network Card for Ethernet (10Base2/10BaseT)
 - IBM Network Card for Token Ring
 - IBM Twinax SCS Interface
 - IBM Coax SCS Interface

Unpacking the Printer

Remove all items from the packing box including packaging pieces. Lift the printer by its handles and place it on a flat surface. If any of the following items are missing, contact your point of purchase:

- IBM Network Printer 17
- Toner cartridge
- Documentation
- Driver software
- Power cord (in some countries the power cord needs to be ordered separately and is shipped in a separate box)

Note: Save all packing materials in case you need to ship or store your printer.

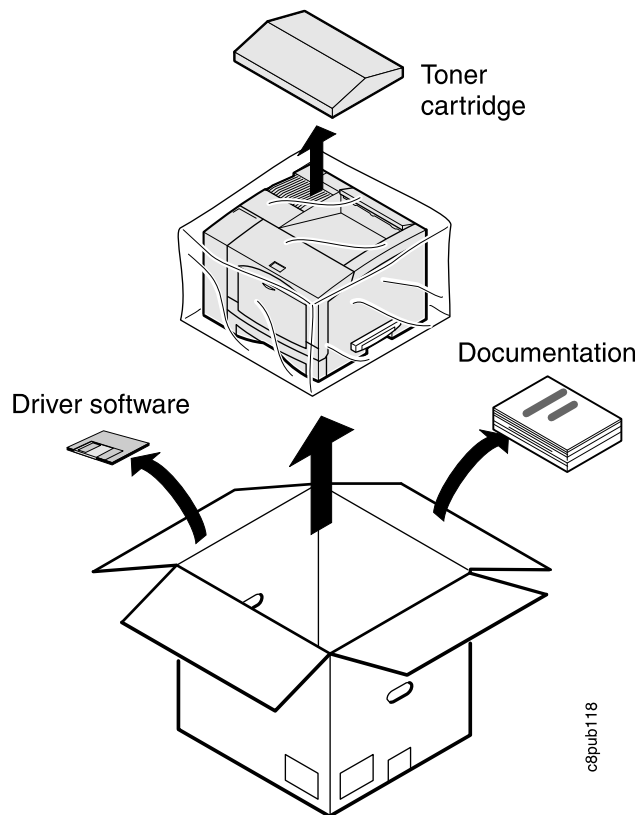

c8pub118

Installing the Toner Cartridge

1. Remove the tape from the front cover. If the auxiliary tray door opens when you remove the tape, please close it.

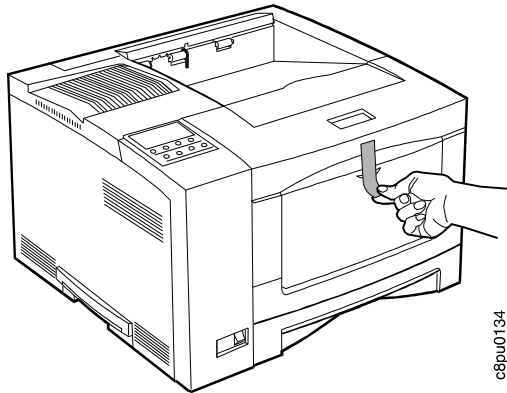

2. Press the button on the top of the printer. Pull the front cover toward you.
Attention: Do not touch the internal parts of the printer.

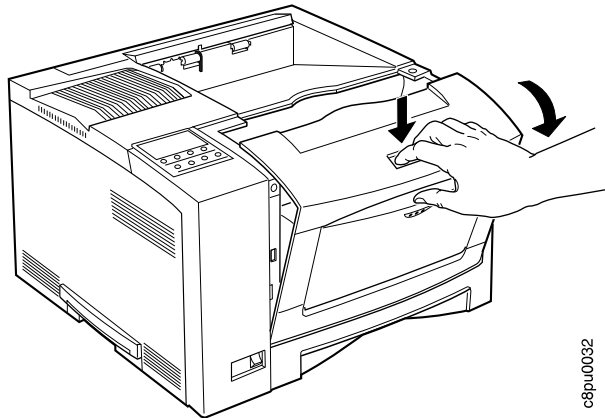

3. Remove the three orange/beige plastic spacers. Save the spacers in case you need to ship the printer.

Attention: If you do not remove the spacers, paper will get stuck in the printer.

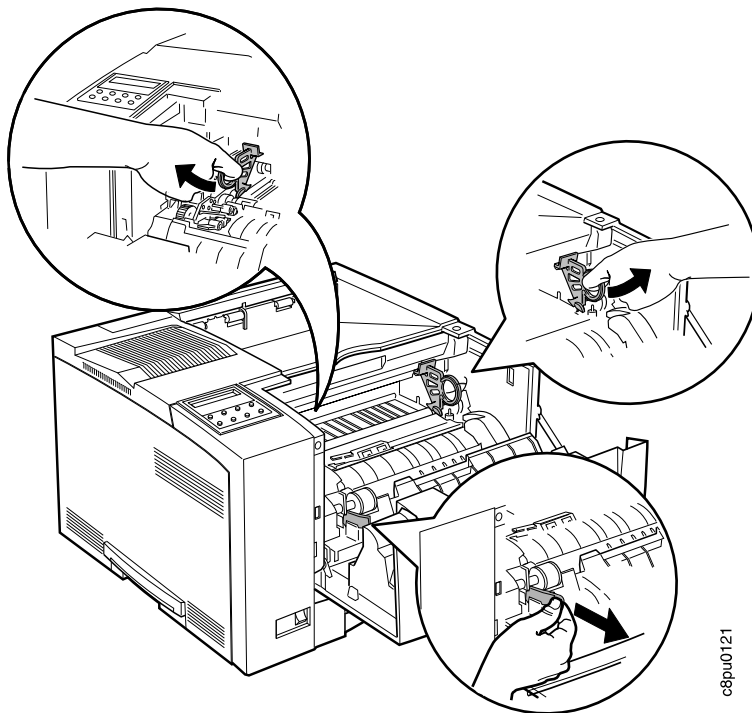

4. Open the foil wrapper and remove the toner cartridge.

Attention: Do not expose the cartridge to direct sunlight. Do not leave the cartridge exposed outside the printer or the foil wrapper for more than five minutes.

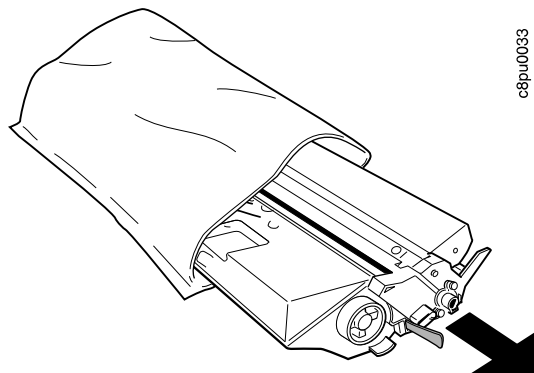

5. Grip the cartridge at each end and gently rock it from side to side to evenly distribute the toner.

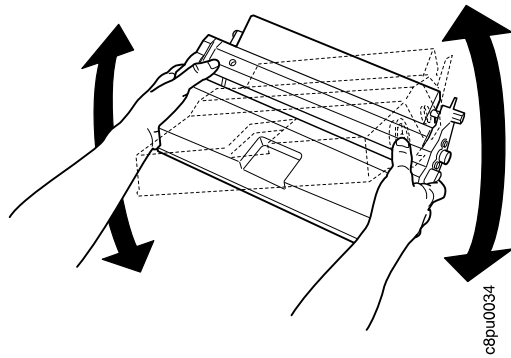

6. Place the cartridge on a flat surface and locate the yellow tape at the end of the cartridge. Pull the end of the tape straight out to remove the toner seal.

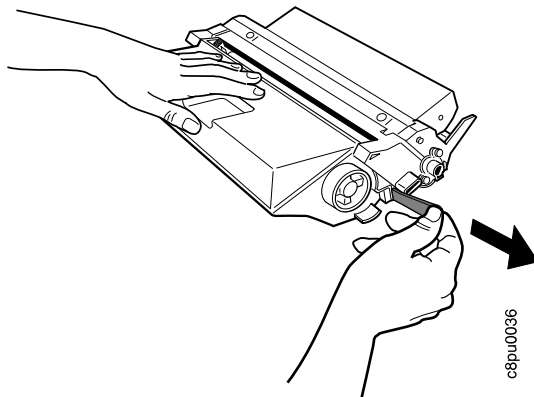

7. Grip the toner cartridge as shown.

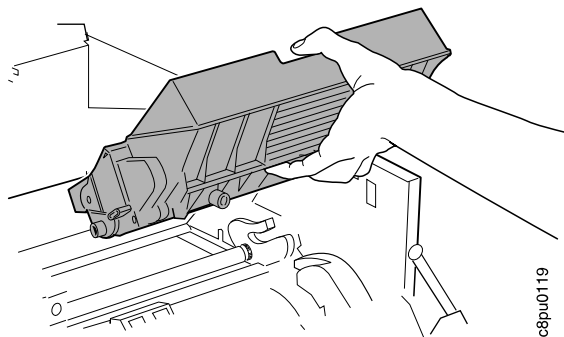

- Slide the cartridge into the printer guide channels. To make sure the toner cartridge is secure, gently press both ends of the cartridge until the cartridge stops.

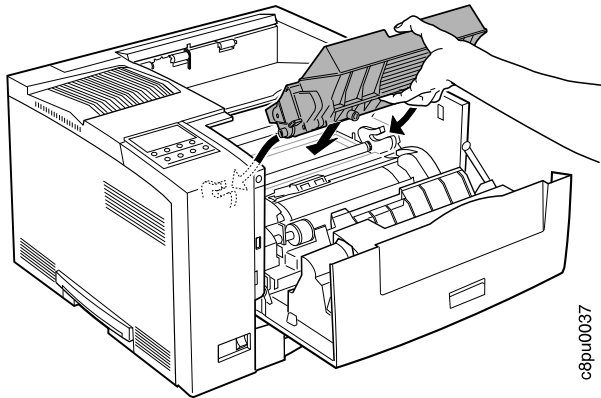

- Close the front cover.

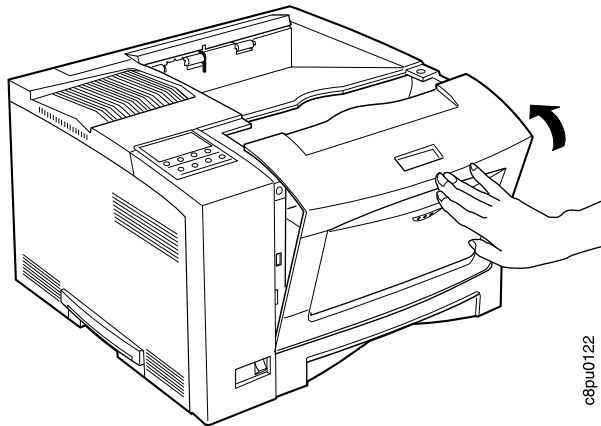

Loading Paper

The Network Printer 17 supports most common sizes of paper, including Letter, A4, 13-inch legal (Folio), 14-inch legal, Executive, and B5-JIS. For a complete description of how to select, load, and handle paper, see the *IBM Network Printer 17: User's Guide*.

1. Remove the paper tray from the printer and place it on a flat surface.

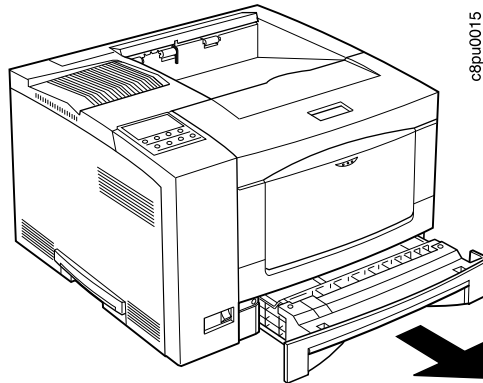

2. Remove the orange/beige spacer from the paper tray. Save it in case you need to ship the printer.

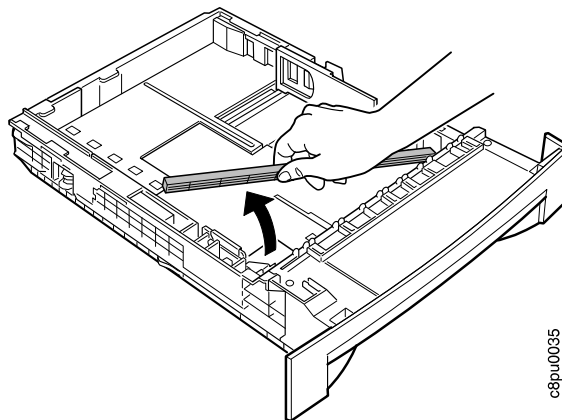

3. Press down on the bottom plate of the paper tray until it snaps into position.

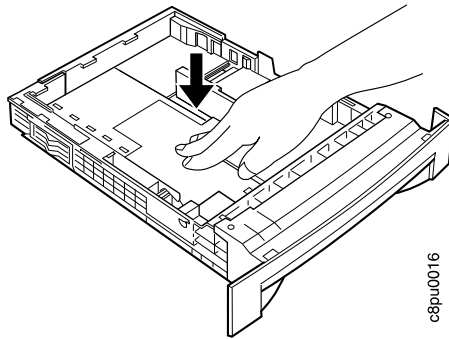

c8pu0016

4. **Important!** If you are using letter paper (8.5 in. X 11 in.), go to Step 5 on page 10. Otherwise, adjust the paper guides as follows:
a. Push the size lock button and slide guide A out.

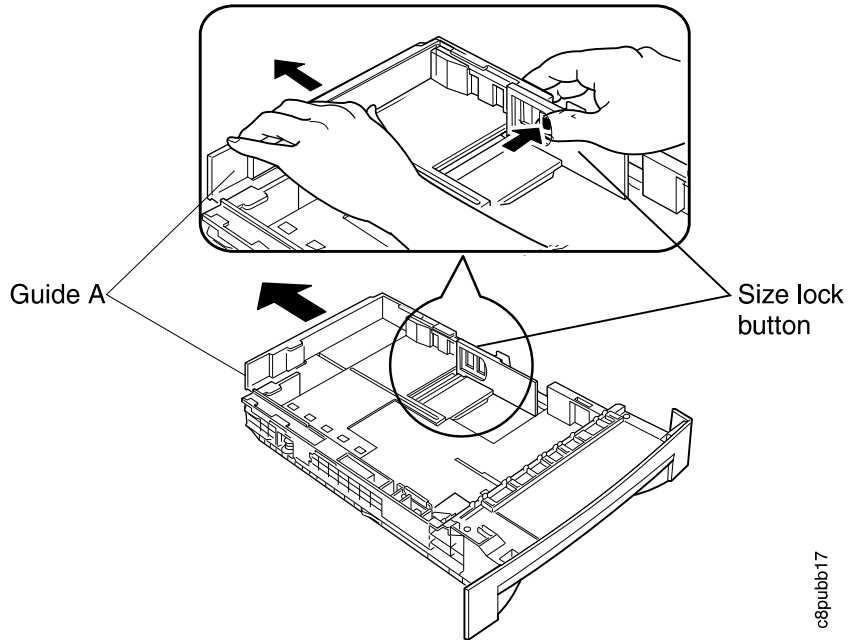

c8pubb17

b. Slide guide B to align it with guide A.

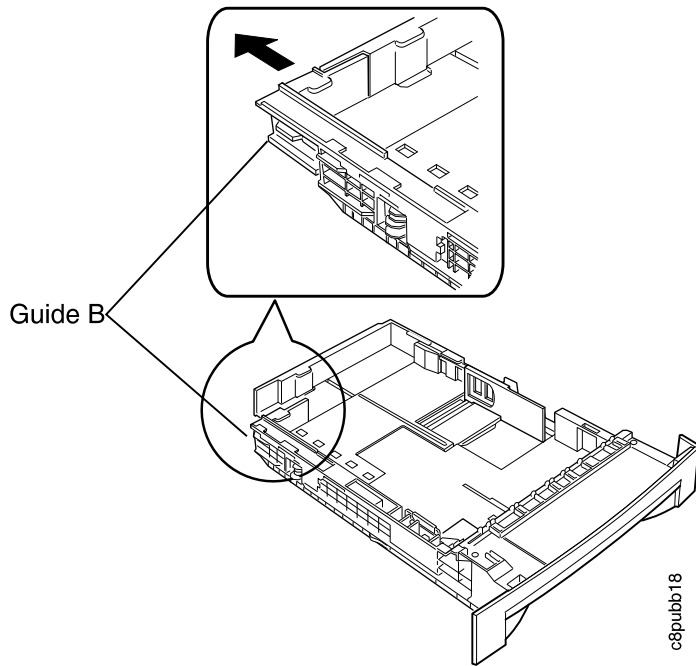

5. Insert the paper into the tray. Make sure you place the corners of the paper under the retaining clip at the front of the tray and the plastic tabs on the end guide.

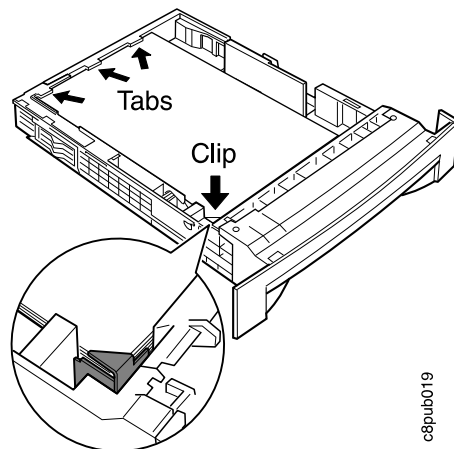

6. If the paper is narrower than the tray, adjust the side guide so that it presses lightly against the side of the paper stack.

Note: The paper should lay flat in the tray; it should not be bowed.

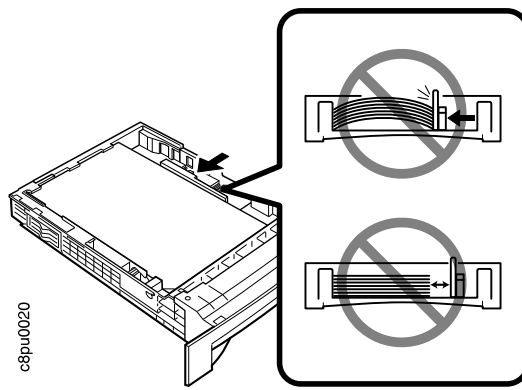

7. Slide the paper tray into the printer until it clicks into place.

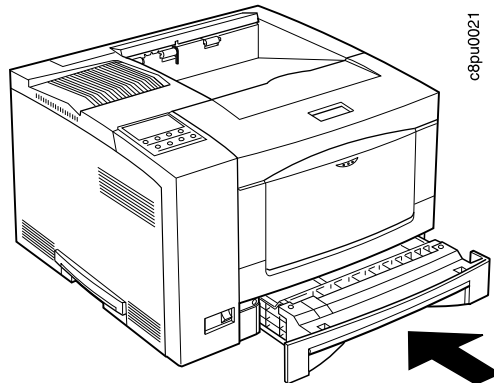

Applying the Operator Panel Template

Important!

Some printers may have the template installed already. If yours does, skip this procedure and go to "Powering On the Printer" on page 14.

1. Peel the thin layer of protective plastic off the message display area.

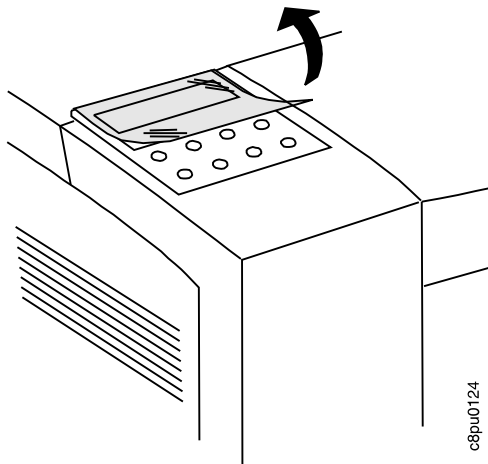

c8pu0124

2. Use a dry cloth or towel to remove dust from the operator panel.
3. Locate the template. The template lists the names of the keys on the operator panel.

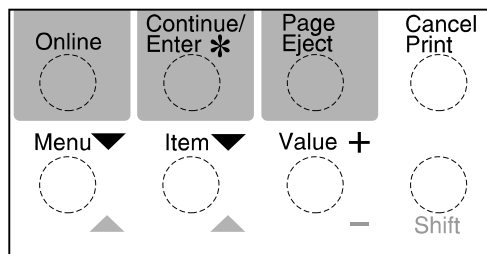

c8pu0005

Note: When you complete the printer setup, see the *IBM Network Printer 17: User's Guide* for a complete description of how to use the keys on the operator panel.

4. Remove the backing from the template.

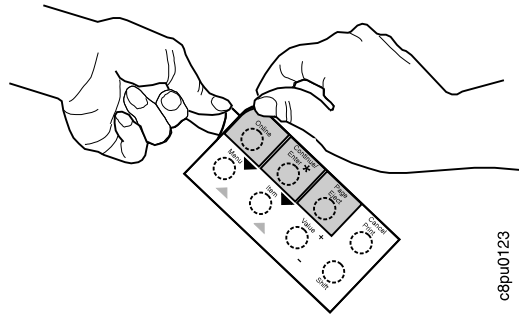

5. Position the template so that the top of the template lines up squarely with the top of the operator panel. Working down from the top of the template, gently press it into place.

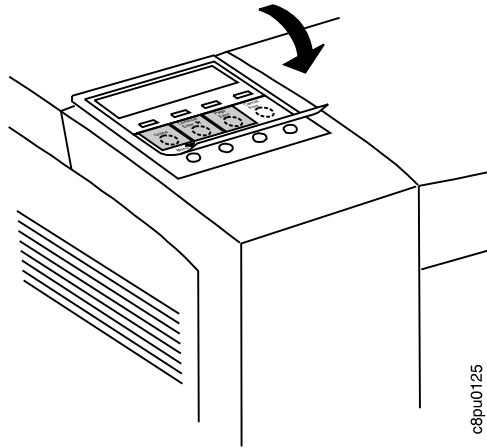

Powering On the Printer

CAUTION:

This product is equipped with a required, country-approved plug. For your safety, use it in conjunction with a properly grounded receptacle.

1. Make sure the printer is off. The power switch is located on the front of the printer. The printer is off when the O on the switch is pressed in.

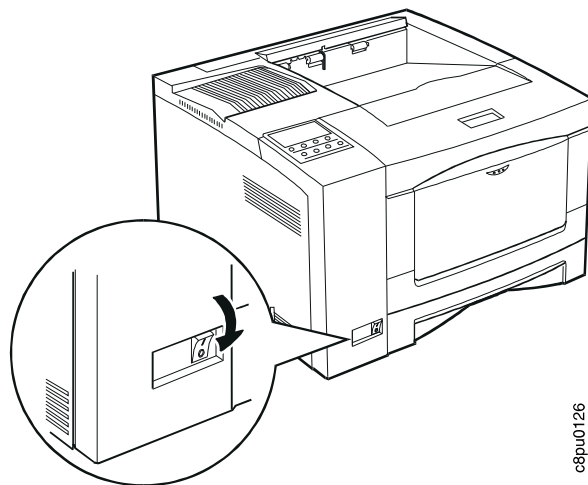

2. Plug the power cord into the socket located on the back of the printer.

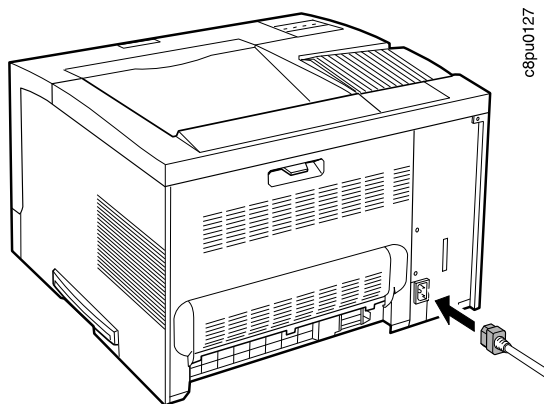

3. Plug the other end of the cord into a grounded AC wall outlet or an equivalent fixture.

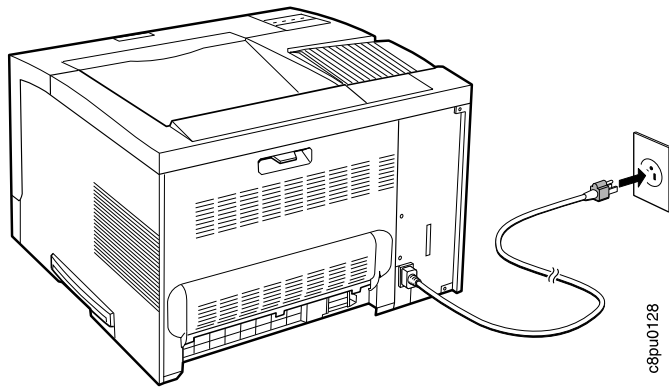

4. To power on the printer, press the I on the power switch.

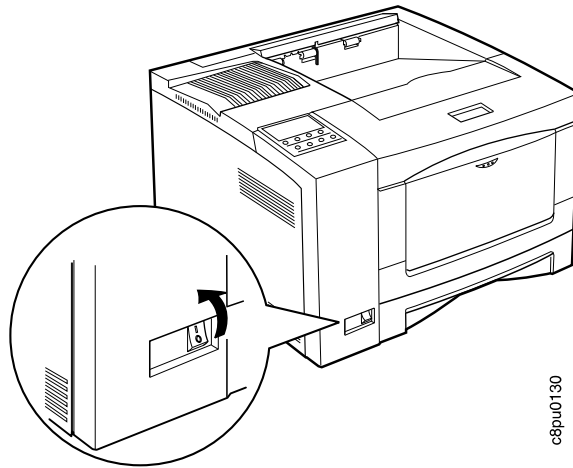

5. The printer displays the message **READY** while it warms up (this usually takes a little longer than a minute). When the printer is ready, it displays the message **READY**.

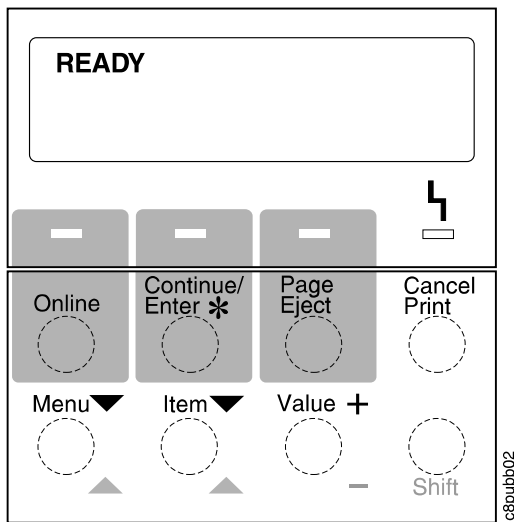

Selecting a Language

Important!

English is the default language for messages and menus. If you use English, you can skip this step and go to "Printing the Printer Configuration Page" on page 20.

To display messages and menus in a language other than English, do the following:

1. Press the **Online** key once; you see OFFLINE in the message display area.

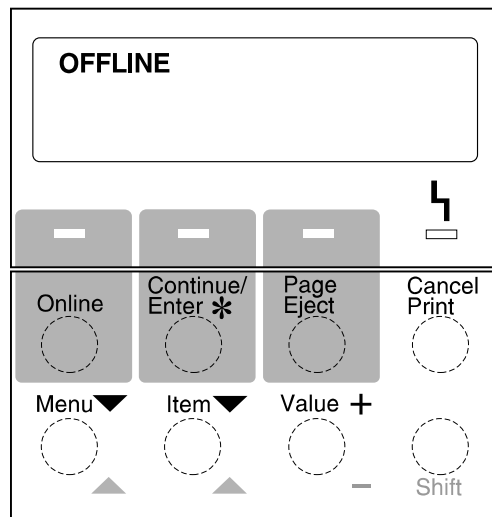

2. Press the **Menu** key until you see LANGUAGE MENU in the message display area. Then press the **Item** key until you see LANG=ENGLISH.

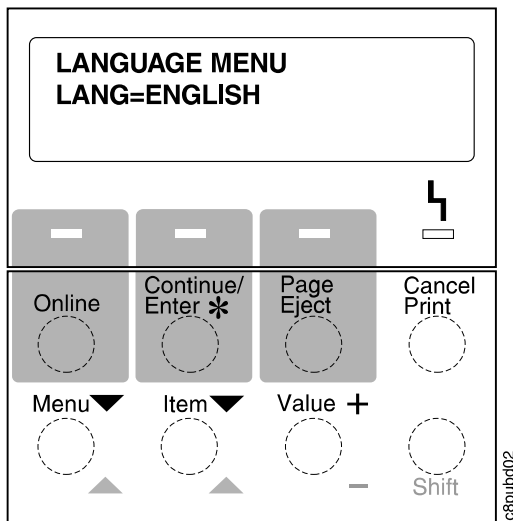

3. Press the **Value** key until you see the language you want to select. In this example, we select GERMAN.

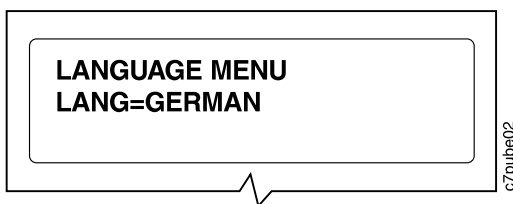

4. To change the value, press the **Continue/Enter** key. An asterisk appears next to the language you select, indicating that it is now active.

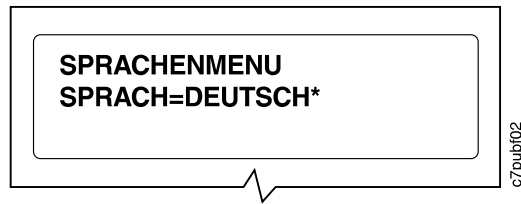

5. Press the **Online** key to make the printer ready. You see the READY message in the language you selected.

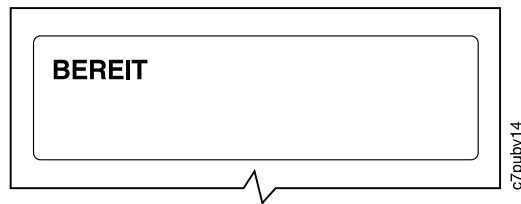

Printing the Printer Configuration Page

Important!

Complete this step to verify that your printer prints. For a complete description of how you can use the printer configuration page to determine what options you have installed and how your printer is configured, see the *IBM Network Printer 17: User's Guide*.

1. On the operator panel, press the **Online** key once; you see OFFLINE in the message display area.

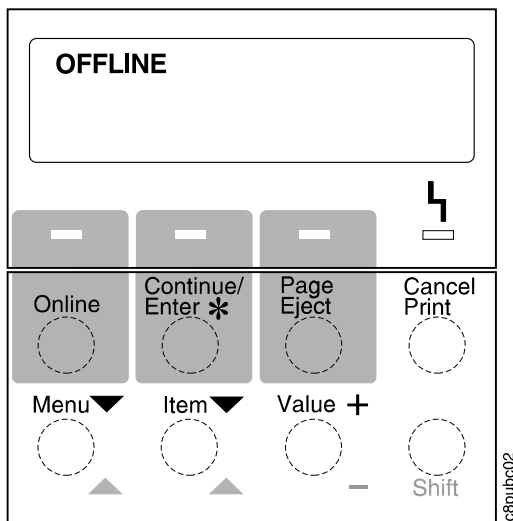

2. Press the **Menu** key. You see TEST MENU in the message display area.

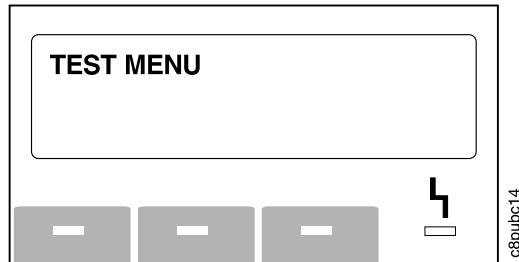

3. Press the **Item** key. You see CONFIG PAGE.

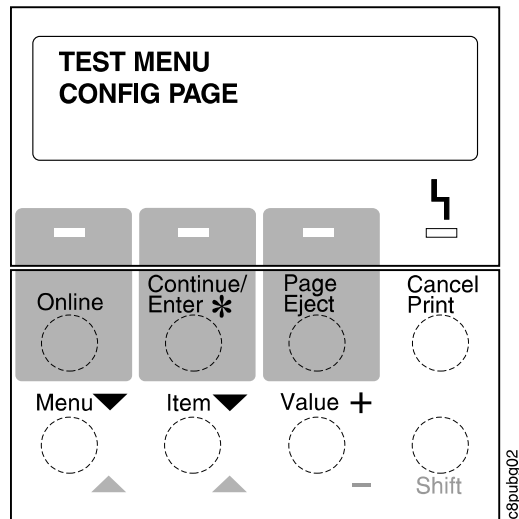

4. Press the **Continue/Enter** key to print the configuration page. (It takes a moment or two.)
5. Press the **Online** key to restore the printer to READY status.

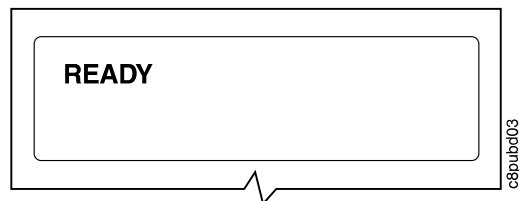

Connecting the Parallel Cable

Important!

You need to supply the parallel cable; it is not included with the Network Printer 17. Properly shielded and grounded cables and connectors (IBM part number 63H2804 or its equivalent) must be used in order to meet FCC emission limits. To install the following optional network interface cards, refer to the *IBM Network Printer 17: User's Guide*.

- IBM Network Card for Ethernet (10Base2/10BaseT)
- IBM Network Card for Token Ring
- IBM Twinax SCS Interface
- IBM Coax SCS Interface

DANGER

To avoid personal risk, do not install or configure a communication port during a lightning storm.

To prevent serious injury from electrical shock when connecting or disconnecting the interface cable, power off the printer and unplug the power cord.

1. Turn off the printer and unplug it from the wall.

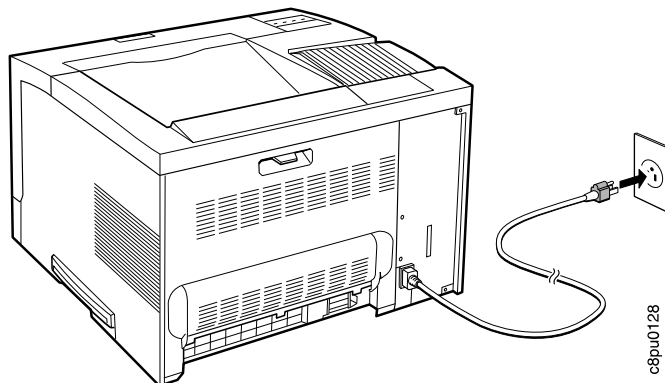

c8pu0128

2. Attach the parallel cable to the parallel interface port on the back of the printer. Make sure you attach the grounding strap on the parallel cable to the grounding screw located just above the parallel interface port.

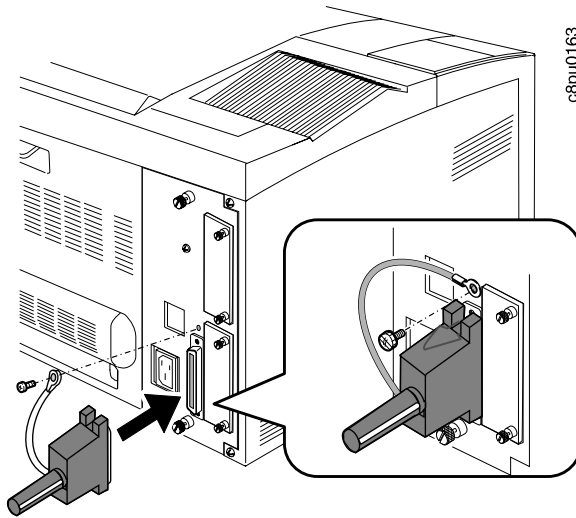

3. Attach the other end of the cable into the parallel interface slot on your PC or workstation.

Installing Printer Drivers

Before you can print from your PC or workstation to your printer, you need to install the right printer driver on your system. The Network Printer 17 includes diskettes which contain PCL5e printer drivers for the following systems:

- Windows 3.1, Windows 3.11, Windows for Workgroups 3.11, Win-OS/2
- Windows 95
- Windows NT 3.51, Windows NT 4.0
- OS/2 2.11, OS/2 Warp
- AIX 3.2.5, AIX 4.1

Notes:

1. For your printer driver to work effectively, you must indicate to your printer driver what features are installed on your printer, for example, what trays are installed, and how much memory is installed. Therefore, after you install a driver, make sure you update it to indicate the features installed on your printer. Also, if you install (or remove) a feature at a later date, make sure you update your printer driver.
2. Each operating system has unique driver installation procedures. For specific installation instructions, see the driver installation documentation for your operating system and the README file on the diskette that includes the driver of your choice.
3. Your printer may include additional drivers not included in this list.
4. PostScript drivers are shipped with the optional PostScript feature.
5. Printer drivers are also available as follows:
 - a. Access the IBM Printing Systems Home Page at:
<http://www.can.ibm.com/ibmprinters>
 - b. Select **Printer Drivers/Product Updates**.
 - c. Use the menu selections to find the printer driver you want.

What To Do Next

Use the following table to help you find information in other documents.

For information about...	See this document...
<ul style="list-style-type: none">• Installing optional features (input trays, output bins, the envelope feeder, the duplex unit, IPDS and PostScript SIMMs, memory upgrades, network interface cards)• Understanding printer messages• Clearing paper jams• Using the operator panel• Navigating through operator panel menus	<i>IBM Network Printer 17: User's Guide</i>
Setting up your printer to use the following cards, including defining network addresses such as the IP address: <ul style="list-style-type: none">• IBM Network Card for Ethernet (10Base2/10BaseT)• IBM Network Card for Token Ring	<i>IBM Network Printers: Ethernet and Token Ring Configuration Guide</i> (This book is shipped with the Ethernet and token ring cards.)
Setting up your printer to use the following cards: <ul style="list-style-type: none">• IBM Twinax SCS Interface• IBM Coax SCS Interface	<i>IBM Network Printers: Twinax/Coax Configuration Guide</i> (This book is shipped with the twinax and coax cards.)

Notices

References in this publication to IBM products, programs or services do not imply that IBM intends to make these available in all countries in which IBM operates. Any reference to an IBM licensed product, program, or service is not intended to state or imply that only IBM's product, program, or service may be used. Any functionally equivalent product, program, or service that does not infringe any of IBM's intellectual property rights may be used instead of the IBM product. Evaluation and verification of operation in conjunction with other products, except those expressly designated by IBM, is the user's responsibility. Any performance data contained in this document was obtained in a controlled environment based on the use of specific data. The results that may be obtained in other operating environments may vary significantly. Users of this document should verify the applicable data in their specific environment. Therefore, such data does not constitute a performance guarantee or warranty. IBM may have patents or pending patent applications covering subject matter in this document. The furnishing of this document does not give you any license to these patents. You can send license inquiries, in writing, to the IBM Corporation, IBM Director of Licensing, 506 Columbus Ave., Thornwood, N.Y. 105894 U.S.A.

Trademarks

The following terms are trademarks of the IBM Corporation in the United States or other countries or both:

AIX
IBM
Intelligent Printer Data Stream
IPDS
OS/2
WIN-OS/2

The following terms are trademarks or registered trademarks of other companies:

PostScript	Adobe Systems, Inc.
PCL5e	Hewlett Packard Co.
Windows	Microsoft Corp.

Readers' Comments — We'd Like to Hear from You

IBM Network Printer 17

Quick Setup

Publication No. G544-5346-01

Use this form to provide comments about this publication, its organization, or subject matter. Understand that IBM may use the information any way it believes appropriate, without incurring any obligation to you. Your comments will be sent to the author's department for the appropriate action. Comments may be written in your language.

Note: IBM publications are not stocked at the location to which this form is addressed. Direct requests for publications or for assistance in using your IBM system, to your IBM representative or local IBM branch office.

	Yes	No
• Does the publication meet your needs?	_____	_____
• Did you find the information:		
Accurate?	_____	_____
Easy to read and understand?	_____	_____
Easy to retrieve?	_____	_____
Organized for convenient use?	_____	_____
Legible?	_____	_____
Complete?	_____	_____
Well illustrated?	_____	_____
Written for your technical level?	_____	_____
• Do you use this publication:		
As an introduction to the subject?	_____	_____
As a reference manual?	_____	_____
As an instructor in class?	_____	_____
As a student in class?	_____	_____
• What is your occupation?	_____	_____

Thank you for your input and cooperation.

Note: You may either send your comments by fax to 1-800-524-1519, or mail your comments. If mailed in the U.S.A., no postage stamp is necessary. For residents outside the U.S.A., your local IBM office or representative will forward your comments.

Comments:

Name

Address

Company or Organization

Phone No.

Readers' Comments — We'd Like to Hear from You
G544-5346-01



Cut or Fold
Along Line

Fold and Tape

Please do not staple

Fold and Tape



NO POSTAGE
NECESSARY
IF MAILED IN THE
UNITED STATES

BUSINESS REPLY MAIL

FIRST-CLASS MAIL PERMIT NO. 40 ARMONK, NEW YORK

POSTAGE WILL BE PAID BY ADDRESSEE

Information Development
The IBM Printing Systems Company
Department H7FE Building 003G
P O Box 1900
BOULDER CO 80301-9817

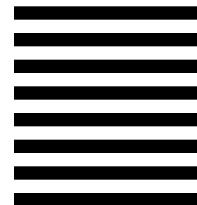

Fold and Tape

Please do not staple

Fold and Tape

G544-5346-01

Cut or Fold
Along Line



Part Number: 63H2494
File Number: S370/4300/9370-16

Printed in U.S.A.

6544-5346-01



63H2494