

InfoPrint 3000



# Operator's Guide



InfoPrint 3000



# Operator's Guide

**Note!**

Before using this information and the product it supports, be sure to read the general information under "Notices" on page xvii.

**Second Edition (October 1998)**

The following paragraph does not apply to any other country where such provisions are inconsistent with local law.

INTERNATIONAL BUSINESS MACHINES CORPORATION PROVIDES THIS PUBLICATION "AS IS" WITHOUT WARRANTY OF ANY KIND, EITHER EXPRESS OR IMPLIED, INCLUDING, BUT NOT LIMITED TO THE IMPLIED WARRANTIES OF MERCHANTABILITY OR FITNESS FOR A PARTICULAR PURPOSE. Some states do not allow disclaimer of express or implied warranties in certain transactions, therefore, this statement may not apply to you.

Changes are made periodically to this publication.

Requests for IBM publications should be made to your IBM representative or to the IBM branch office serving your locality. If you request publications from the address given below, your order will be delayed, because publications are not stocked there.

A Reader's Comment Form is provided at the back of this publication. If the form has been removed, comments can be sent by fax to 1-800-524-1519, by E-mail to [print\\_pubs@us.ibm.com](mailto:print_pubs@us.ibm.com), or by mail to:

IBM Printing Systems Company  
Department H7FE Building 003G  
Information Development  
PO Box 1900  
Boulder CO USA 80301-9191

IBM may use or distribute whatever information you supply in any way it believes appropriate without incurring any obligation to you.

Visit our home page at: <http://www.printers.ibm.com>

© Copyright International Business Machines Corporation 1998. All rights reserved.

Note to U.S. Government Users — Documentation related to restricted rights — Use, duplication or disclosure is subject to restrictions set forth in GSA ADP Schedule Contract with IBM Corp.

---

## Online Documentation Authorization

For online versions of this book, we authorize you to:

- Copy, modify, and print the documentation contained on the media, for use within your enterprise, provided you reproduce the copyright notice, all warning statements, and other required statements on each copy or partial copy.
- Transfer the original unaltered copy of the documentation when you transfer the related IBM product (which may be either machines you own, or programs, if the program's license terms permit a transfer). You must, at the same time, destroy all other copies of the documentation.

You are responsible for payment of any taxes, including personal property taxes, resulting from this authorization.

THERE ARE NO WARRANTIES, EXPRESS OR IMPLIED, INCLUDING THE WARRANTIES OF MERCHANTABILITY AND FITNESS FOR A PARTICULAR PURPOSE.

Some jurisdictions do not allow the exclusion of implied warranties, so the above exclusion may not apply to you.

Your failure to comply with the terms above terminates this authorization. Upon termination, you must destroy your machine readable documentation.



# Contents

<b>Online Documentation Authorization</b>	<b>iii</b>	Power Control Panel	18
<b>Figures</b>	<b>ix</b>	Developer Area	20
<b>Tables</b>	<b>xi</b>	Forms Input and Transfer Station Area	22
<b>Statement of Limited Warranty</b>	<b>xiii</b>	Printer Control Panel	23
Production Status	xiii	Transfer Station Control Lever and Tractor Control Levers	25
The IBM Warranty	xiii	Puller Control Lever	26
Warranty Service	xiv	Fuser Entry Area	26
Extent of Warranty	xiv	Stacker Area	27
Limitation of Liability	xv	Stacker Control Panel	28
<b>Notices</b>	<b>xvii</b>	Forms Length and Width Controls	30
Trademarks	xviii	Stacker Height Control	31
Communication Statements	xviii	Rear Service Area	32
Safety Notice Conventions	xx	<b>Chapter 4. Using the Display Touch Screen</b>	<b>33</b>
Caution Notices	xx	Using the Display Touch Screen in Duplex and Dual Simplex Modes	33
Danger Notices	xxi	Display Touch Screen Windows	34
Safety Notices	xxii	Keyboard, Keypad, and Hexpad Windows	35
<b>Preface</b>	<b>xxv</b>	Selection Devices on the Display Touch Screen Windows	37
About This Book	xxv	Fingertip Control	37
How to Use This Book	xxv	Pushbuttons	37
Terminology	xxvi	Selectable Field	37
Notation Conventions	xxvi	Radio Buttons	38
Pictorial Conventions	xxvi	Scroll Bar	38
InfoPrint 3000 Library	xxvii	Inactive Items	38
Related Publications	xxvii	Control Procedures	39
<b>Summary of Changes</b>	<b>xxix</b>	System Menu	39
<b>Chapter 1. Introduction</b>	<b>1</b>	Multiple Procedures	39
System Characteristics	1	Screen Saver Timeout	40
Printer Characteristics	3	Symbols and Visual Cues	41
System Components	3	<b>Chapter 5. Task Summary</b>	<b>43</b>
Duplex Printing Applications	4	Operate Pull-Down Menu	45
Simplex and Dual Simplex Printing Applications	5	Configure Pull-Down Menu	47
Inline Configuration for Duplex	6	Analyze Pull-Down Menu	49
Left Angle Configuration for Duplex	7	Options Pull-Down Menu	50
Left Angle Configuration for Dual Simplex	8	Help Pull-Down Menu	52
<b>Chapter 2. Operator's Overview</b>	<b>9</b>	Additional Help	53
Operator Responsibilities	9	<b>Chapter 6. Operator Responsibilities</b>	<b>55</b>
Normal Operation (Ready Status)	11	Controlling the System Power	56
Operator Intervention (Not Ready Status)	12	Local/Remote Power Control	57
Service Call Procedure	13	Powering On the System	57
<b>Chapter 3. Functional Areas</b>	<b>15</b>	Powering Off the System	60
Forms and the Forms Path	15	Shutting Down and Restarting the System	61
Control Unit Area	17	Shutting Down the System	61
Operator Alert Area	18	Restarting the System	62
Display Touch Screen	18	Enabling and Disabling Attachments	63
		Remote Channel Enable/Disable	63
		Local Channel Enable/Disable	63
		Adjusting the Display Touch Screen Monitor	65
		User Controls	65

On-Screen-Display Controls . . . . .	66
Adjusting the Print Position . . . . .	68
Adjusting the Volume of the Operator Alert Assembly . . . . .	74
Advancing Forms Using the NPRO and NPRO Page Functions . . . . .	75
NPRO Procedure . . . . .	75
NPRO Page Procedure . . . . .	76
Canceling a Job . . . . .	78
Changing the Password or Authorization Level . . . . .	79
Checking for a Front-Facing Page . . . . .	81
Checking the Forms Alignment . . . . .	84
Checking Print Quality . . . . .	85
Cleaning the Oiler Belt . . . . .	86
Cleaning the Printer . . . . .	88
Connecting an Accessory to the Operator Alert Contacts . . . . .	101
Loading Forms (Simplex or Dual Simplex Mode) . . . . .	102
Loading Forms (Duplex Mode) . . . . .	115
Adjusting the Stacker Table Height . . . . .	117
Preprocessing and Postprocessing Instructions . . . . .	118
Powering On and Off Pre/Post Devices . . . . .	118
Enabling/Disabling Pre/Post Interfaces . . . . .	118
Using the Printer Stacker . . . . .	119
Error and Jam Recovery . . . . .	119
Adding Supplies . . . . .	119
Nonprocess Runout (NPRO) . . . . .	120
Recovering from a Forms Jam (Simplex Operations) . . . . .	121
Jams Within the Printer Engine . . . . .	122
Jam Recovery Procedures . . . . .	123
Jams Between the Printer and a Postprocessing Device . . . . .	126
Recovering from a Forms Jam (Duplex Operations) . . . . .	127
Jams Within Printer 1 . . . . .	129
Jams Within Printer 2 . . . . .	131
Jam Between Printer 1 and Printer 2 . . . . .	134
Jams Between the Printer and a Postprocessing Device . . . . .	134
Recovering from a Forms Jam in the Postprocessing Device . . . . .	135
Clearing the Forms Path . . . . .	136
Transfer Station Area . . . . .	136
Fuser and Stacker Areas . . . . .	140
Stacker and Pendulum Area . . . . .	143
Suggestions for Preventing Jams . . . . .	144
Reporting Printer Usage . . . . .	146
Running Traces . . . . .	148
Adjusting the Preheat Temperature . . . . .	150
Poor Fusing - Simplex Mode . . . . .	151
Forms Stick Together . . . . .	151
Heat Damage — Printer Running . . . . .	151
Thread/Align Forms . . . . .	152
Forms Are Loaded Through Both Printers . . . . .	154
Forms Are Not Loaded In Printer 2 . . . . .	158
Forms Are Broken Between the Printers . . . . .	162
Threading the Buffer/Flipper Unit . . . . .	167
Straight Line Configuration . . . . .	167
Left Angle Configuration . . . . .	168
Unloading the Stacker . . . . .	169
Switching Printer Modes (Dual Simplex/Duplex) . . . . .	172

Switching from Duplex to Dual Simplex Mode . . . . .	172
Switching from Dual Simplex to Duplex Mode . . . . .	172
Switching Print Resolution . . . . .	174

## **Chapter 7. Ordering and Replacing Supplies . . . . . 175**

Supplies . . . . .	176
IBM Supplies Worksheet . . . . .	176
Ordering Supplies . . . . .	177
Maintenance Supply Items . . . . .	177
Customer-Replaceable Supply Items . . . . .	177
Warranty Returns . . . . .	178
Storing Supplies . . . . .	178
Adding Fuser Oil . . . . .	179
Changing the Toner Cartridge . . . . .	182
Checking the Toner Collector . . . . .	186
Changing the Toner Collector . . . . .	188
Changing the Developer Mix . . . . .	191
Checking the Fine Filter . . . . .	200
Changing the Fine Filter . . . . .	201
Changing the Oiler Belt . . . . .	204
Checking the Absorbent Pad in the Oil Pan . . . . .	212

## **Chapter 8. Configuring the System . . . . . 217**

Changing the Language of Messages . . . . .	218
Configuring the Printer . . . . .	219
Printer Configuration Information . . . . .	220
Configuring the Host Attachments . . . . .	229
Parallel Channel Configuration Information . . . . .	232
ESCON Channel Configuration Information . . . . .	234
Token Ring TCP/IP Attachment Information . . . . .	235
Ethernet TCP/IP Attachment Information . . . . .	237
FDDI TCP/IP Attachment Information . . . . .	239
Configuring Preprocessing/Postprocessing Devices/Interfaces . . . . .	241
Pre/Postprocessor Configuration Values . . . . .	243
Configuring Remote Access . . . . .	245
Defining Forms . . . . .	247
Duplex Configuration Worksheet . . . . .	251
Simplex Configuration Worksheet . . . . .	258
Form Identification Worksheets . . . . .	263
Form Identification Worksheet . . . . .	264

## **Chapter 9. Print Quality and Problem Solving . . . . . 265**

Print Quality Problems . . . . .	266
Sudden Failures . . . . .	268
Problem Solving Tips and Suggested Actions . . . . .	269

## **Chapter 10. Responding to Messages 271**

Program Check Messages . . . . .	272
Soft Program Check . . . . .	272
Hard Program Checks . . . . .	273
Printer Error Messages . . . . .	274
Out Of Supplies Messages . . . . .	276
Intervention Required Messages . . . . .	277
Status Messages . . . . .	278
Status Message Summary . . . . .	279
Messages with System Reference Codes . . . . .	280



**Appendix A. Valid Form Lengths in Inches. . . . . 291**

**Appendix B. Physical System Layouts 293**  
Simplex Models . . . . . 293  
Duplex Models. . . . . 294

**Glossary. . . . . 297**

**Index . . . . . 305**

**Readers' Comments — We'd Like to Hear from You . . . . . 311**



---

# Figures

1. Forms Path Through a Printer Engine	16	25. Reprint Path Length . . . . .	121
2. Stacker Control Panel . . . . .	28	26. Duplex Mode Reprint Path Length . . . . .	127
3. Stacker Height Control . . . . .	31	27. Reestablishing Forms Alignment . . . . .	130
4. Display Touch Screen Window Components	34	28. Printer Usage Sheet . . . . .	147
5. Numeric Keypad Window . . . . .	36	29. Traces Window . . . . .	148
6. Alphanumeric Keyboard Window . . . . .	37	30. Setup Window for Thread/Align Forms	152
7. Grayed Out Check Reset Pushbutton	38	31. Main Thread/Align Forms Window	154
8. System Menu Symbol - Pull-Down Menu	39	32. Inline Configuration . . . . .	167
9. Procedure Windows in Cascade Format	40	33. Left Angle Configuration . . . . .	168
10. Procedure Access Chart . . . . .	44	34. Configure Printer Window . . . . .	219
11. Operate Pull-Down Menu . . . . .	45	35. Configure Pre/Postprocessors Window - Duplex Mode . . . . .	242
12. Configure Pull-Down Menu . . . . .	47	36. Define Forms Window - Duplex Mode	248
13. Analyze Pull-Down Menu . . . . .	49	37. Soft Program Check Window . . . . .	272
14. Options Pull-Down Menu . . . . .	50	38. Hard Program Check Window - Normal Operations . . . . .	273
15. General Help Window . . . . .	52	39. Printer Error Window . . . . .	274
16. Define Forms Help Window . . . . .	53	40. Out of Supplies Window . . . . .	276
17. Operator Console User Controls . . . . .	65	41. Intervention Required Window . . . . .	277
18. On-Screen-Display Main Menu . . . . .	66	42. Printer Status Window . . . . .	278
19. Good Registration . . . . .	68	43. Simplex Configuration . . . . .	293
20. Poor Registration . . . . .	69	44. Duplex Inline Configuration . . . . .	294
21. Factory Set Default Registration . . . . .	71	45. Duplex Left Angle Configuration . . . . .	295
22. Sample Field Adjusted Registration . . . . .	72		
23. Options Pull-Down Menu . . . . .	80		
24. Stacker Height Control . . . . .	117		



---

## Tables

1. InfoPrint 3000 Printer Specification Summary	2	17. Parallel Channel Attachment Items . . . . .	232
2. Operator Responsibilities . . . . .	9	18. ESCON Channel Attachment Items . . . . .	234
3. Developer Area Controls. . . . .	21	19. Token Ring TCP/IP Attachment Items	235
4. Printer Control Panel . . . . .	23	20. Ethernet TCP/IP Attachment Items . . . . .	237
5. Symbols and Visual Cues . . . . .	41	21. FDDI TCP/IP Attachment Items . . . . .	239
6. Remote Power Control . . . . .	57	22. Preprocessing/Postprocessing Interface Options . . . . .	241
7. Remote System Power Control - Duplex Models . . . . .	58	23. Pre/Postprocessor Device Configuration Items . . . . .	243
8. Local System Power Control - Duplex Models	59	24. Configuration Worksheet – Duplex Models	251
9. User Controls on the Monitor . . . . .	65	25. Configuration Worksheet – Simplex Model	258
10. Submenu Icons . . . . .	66	26. Form Identification Worksheet . . . . .	264
11. Pre/Postprocessor Interface Options	118	27. Print Quality Symptom Table . . . . .	266
12. Jam Recovery Procedures - Simplex Mode	123	28. Miscellaneous Problems . . . . .	269
13. Printer 1 Jam Recovery Procedures - Duplex Mode . . . . .	129	29. Printer Status Window - Status Field Messages . . . . .	279
14. Printer 2 Jam Recovery Procedures - Duplex Mode . . . . .	131	30. SRC Messages . . . . .	281
15. IBM Supplies Worksheet. . . . .	177	31. Examples of Some Valid Form Lengths in Inches . . . . .	291
16. Printer Configuration Items. . . . .	221		



---

## Statement of Limited Warranty

*The warranties provided by IBM in this Statement of Limited Warranty apply only to Machines you originally purchase for your use, and not for resale, from IBM or an IBM authorized reseller. The term "Machine" means an IBM machine, its features, conversions, upgrades, elements, or accessories, or any combination of them. Machines are subject to these terms only if purchased in the United States or Puerto Rico, or Canada, and located in the country of purchase. If you have any questions, contact IBM or your reseller.*

**Machine:** InfoPrint 3000

Warranty Period\*: 90 days

*\*Elements and accessories are warranted for three months. Contact your place of purchase for warranty service information.*

---

## Production Status

Each Machine is manufactured from new parts, or new and serviceable used parts (which perform like new parts). In some cases, the Machine may not be new and may have been previously installed. Regardless of the Machine's production status, IBM's warranty terms apply.

---

## The IBM Warranty

IBM warrants that each Machine 1) is free from defects in materials and workmanship and 2) conforms to IBM's Official Published Specifications. IBM calculates the expiration of the warranty period from the Machine's Date of Installation. The date on your receipt is the Date of Installation, unless IBM or your reseller informs you otherwise.

During the warranty period, IBM or your reseller will provide warranty service under the type of service designated for the Machine and will manage and install engineering changes that apply to the Machine. IBM or your reseller will specify the type of service.

For a feature, conversion, or upgrade, IBM or your reseller may require that the Machine on which it is installed be 1) the designated, serial-numbered Machine and 2) at an engineering-change level compatible with the feature, conversion, or upgrade. Some of these transactions (called "Net-Priced" transactions) may include additional parts and associated replacement parts that are provided on an exchange basis. All removed parts become the property of IBM and must be returned to IBM. Replacement parts assume the remaining warranty of the parts they replace.

If a Machine does not function as warranted during the warranty period, IBM or your reseller will repair or replace it without charge. If IBM or your reseller is unable to do so, you may return it to your place of purchase and your money will be refunded.

If you transfer a Machine to another user, warranty service is available to that user for the remainder of the warranty period. You should give your proof of purchase and this Statement to that user.

---

## Warranty Service

To obtain warranty service for the Machine, you should contact your reseller or call IBM. In the United States, call IBM at **1-800-IBM-SERV (426-7378)**. In Canada, call IBM at **1-800-465-6666**. You may be required to present proof of purchase.

Depending on the Machine, the service may be 1) a “Repair” service at your location (called “On-site”) or at one of IBM’s or a reseller’s service locations (called “Carry-in”) or 2) an “Exchange” service, either On-site or Carry-in.

When a type of service involves the exchange of a Machine or part, the item IBM or your reseller replaces becomes its property and the replacement becomes yours. The replacement may not be new, but will be in good working order.

It is your responsibility to:

1. Obtain authorization from the owner (for example, your lessor) to have IBM or your reseller service a Machine that you do not own;
2. Where applicable, before service is provided —
  - a. Follow the problem determination, problem analysis, and service request procedures that IBM or your reseller provide,
  - b. Secure all programs, data, and funds contained in a Machine,
  - c. Inform IBM or your reseller of changes in a Machine’s location, and
  - d. For a Machine with exchange service, remove all features, parts, options, alterations, and attachments not under warranty service. Also, the Machine must be free of any legal obligations or restrictions that prevent its exchange; and
3. Be responsible for loss of, or damage to, a Machine in transit when you are responsible for the transportation charges.

---

## Extent of Warranty

IBM does not warrant uninterrupted or error-free operation of a Machine.

Misuse, accident, modification, unsuitable physical or operating environment, improper maintenance by you, or failure caused by a product for which IBM is not responsible may void the warranties.

THESE WARRANTIES REPLACE ALL OTHER WARRANTIES, EXPRESS OR IMPLIED, INCLUDING, BUT NOT LIMITED TO, THE IMPLIED WARRANTIES OF MERCHANTABILITY AND FITNESS FOR A PARTICULAR PURPOSE. HOWEVER, SOME LAWS DO NOT ALLOW THE EXCLUSION OF IMPLIED WARRANTIES. IF THESE LAWS APPLY, THEN ALL EXPRESS AND IMPLIED WARRANTIES ARE LIMITED IN DURATION TO THE WARRANTY PERIOD. NO WARRANTIES APPLY AFTER THAT PERIOD.

In Canada, warranties include both warranties and conditions.

Some jurisdictions do not allow limitations on how long an implied warranty lasts, so the above limitation may not apply to you.



---

## Limitation of Liability

Circumstances may arise where, because of a default on IBM's part (including fundamental breach) or other liability (including negligence and misrepresentation), you are entitled to recover damages from IBM. In each such instance, regardless of the basis on which you are entitled to claim damages, IBM is liable only for:

1. Bodily injury (including death), and damage to real property and tangible personal property; and
2. The amount of any other actual loss or damage, up to the greater of \$100,000 or the charge for the Machine that is the subject of the claim.

Under no circumstances is IBM liable for any of the following:

1. Third-party claims against you for losses or damages (other than those under the first item listed above);
2. Loss of, or damage to, your records or data; or
3. Economic consequential damages (including lost profits or savings) or incidental damages, even if IBM is informed of their possibility.

Some jurisdictions do not allow the exclusion or limitation of incidental or consequential damages, so the above limitation or exclusion may not apply to you.

This warranty gives you specific legal rights and you may also have other rights which vary from jurisdiction to jurisdiction.



---

## Notices

References in this publication to IBM products, programs, or services do not imply that IBM intends to make these available in all countries in which IBM operates. Any reference to an IBM product, program, or service is not intended to state or imply that only that IBM product, program, or service may be used. Any functionally equivalent product, program, or service that does not infringe any of the intellectual property rights of IBM may be used instead of the IBM product, program, or service. The evaluation and verification of operation in conjunction with other products, except those expressly designated by IBM, are the responsibility of the user.

IBM may have patents or pending patent applications covering subject matter in this publication. The furnishing of this publication does not give you any license to these patents. You can send license inquiries, in writing, to the IBM Director of Commercial Relations, IBM Corporation, Purchase, NY 10577, U.S.A.

For online versions of this book, we authorize you to:

- Copy, modify, and print the documentation contained on the media, for use within your enterprise, provided you reproduce the copyright notice, all warning statements, and other required statements on each copy or partial copy.
- Transfer the original unaltered copy of the documentation when you transfer the related IBM product (which may be either machines you own, or programs, if the program's license terms permit a transfer). You must, at the same time, destroy all other copies of the documentation.

You are responsible for payment of any taxes, including personal property taxes, resulting from this authorization.

THERE ARE NO WARRANTIES, EXPRESS OR IMPLIED, INCLUDING THE WARRANTIES OF MERCHANTABILITY AND FITNESS FOR A PARTICULAR PURPOSE.

Some jurisdictions do not allow the exclusion of implied warranties, so the above exclusion may not apply to you.

Your failure to comply with the terms above terminates this authorization. Upon termination, you must destroy your machine readable documentation.

---

## Trademarks

The following terms used in this publication are trademarks of the IBM Corporation in the United States or other countries or both:

AFCCU and Advanced Function Common Control Unit  
AFP and Advanced Function Presentation  
Advanced Function Printing  
AIX®  
AIX/6000  
BCOCA and Bar Code Object Content Architecture  
ESCON®  
GDDM  
IBM®  
InfoPrint  
IPDS and Intelligent Printer Data Stream  
MVS and MVS/SP  
OS/2®  
PSF and Print Services Facility  
PSF/6000  
S/390  
System/360  
System/370  
XGA

---

## Communication Statements

### *Federal Communications Commission (FCC) Statement*

**Note:** This equipment has been tested and found to comply with the limits for a Class A digital device, pursuant to Part 15 of the FCC Rules. These limits are designed to provide reasonable protection against harmful interference when the equipment is operated in a commercial environment. This equipment generates, uses, and can radiate radio frequency energy and, if not installed and used in accordance with the instruction manual, may cause harmful interference to radio communications. Operation of this equipment in a residential area is likely to cause harmful interference, in which case the user will be required to correct the interference at his own expense.

Properly shielded and grounded cables and connectors must be used in order to meet FCC emission limits. IBM is not responsible for any radio or television interference caused by using other than recommended cables and connectors or by unauthorized changes or modifications to this equipment. Unauthorized changes or modifications could void the user's authority to operate the equipment.

This device complies with Part 15 of the FCC Rules. Operation is subject to the following two conditions: (1) this device may not cause harmful interference, and (2) this device must accept any interference received, including interference that may cause undesired operation.

**Canadian Department of Communications compliance statement:** This Class A digital apparatus meets the requirements of the Canadian Interference-Causing Equipment Regulations.

**Avis de conformité aux normes du ministère des Communications du Canada:** Cet appareil numérique de la classe A respecte toutes les exigences du Règlement sur le matériel brouilleur du Canada.

**The United Kingdom Telecommunications Statement of Compliance:** This apparatus is approved under the approval No. NS/G/1234/J/100003 for the indirect connections to the public telecommunications systems in the United Kingdom.

**Statement for CISPR 22 Edition 2 Compliance:** Warning: This is a Class A product. In a domestic environment this product may cause radio interference in which case the user may be required to take adequate measures.

**German Conformity Statement:** Dieses Gerät erfüllt die Bedingungen der EN 55022 Klasse A. Für diese Klasse von Geräten gilt folgende Bestimmung nach dem EMVG:

Geräte dürfen an Orten, für die sie nicht ausreichend entstört sind, nur mit besonderer Genehmigung des Bundesministers für Post und Telekommunikation oder des Bundesamtes für Post und Telekommunikation betrieben werden. Die Genehmigung wird erteilt, wenn keine elektromagnetischen Störungen zu erwarten sind.

(Auszug aus dem EMVG vom 9.Nov.92, Para.3, Abs.4)

**European Community (EC) Conformity Statement:** This product is in conformity with the protection requirements of EC Council Directive 89/336/EEC on the approximation of the laws of the Member States relating to electromagnetic compatibility. IBM cannot accept responsibility for any failure to satisfy the protection requirements resulting from a non-recommended modification of the product, including the fitting of non-IBM option cards.

**Shielded Cables (European Statement):** Properly shielded and grounded cables and connectors must be used in order to reduce the potential for causing interference to radio and TV communication and to other electrical or electronic equipment. Such cables and connectors are available from IBM authorized dealers. IBM cannot be responsible for any interference caused by using other than recommended cables and connectors.

**Japanese VCCI:**

この装置は、第一種情報装置（商工業地域において使用されるべき情報装置）で商工業地域での電波障害防止を目的とした情報処理装置等電波障害自主規制協議会（VCCI）基準に適合しております。

従って、住宅地域またはその隣接した地域で使用すると、ラジオ、テレビジョン受信機等に受信障害を与えることがあります。

取扱説明書に従って正しい取り扱いをして下さい。

100A

Taiwan EMC:

警告使用者：  
這是甲類的資訊產品，在  
居住的環境中使用時，可  
能會造成射頻干擾，在這  
種情況下，使用者會被要  
求採取某些適當的對策。

---

## Safety Notice Conventions

This publication contains safety notices that warn users of situations that could cause them harm.

### Caution Notices

Caution notices make users aware of hazards that can cause minor or moderate personal injuries, such as cuts or burns. The following notices are examples of the kinds of caution notices that can appear in an Operator's Guide.



**CAUTION:**

<70> The oiler belt, oiler wick roll, and their environments are *high-temperature* areas. Be very careful when working in these areas.

CAUT0100



**CAUTION:**

<72> As you load forms, be careful to avoid injuries:

The tractor covers are spring-loaded and can pinch if they snap shut unexpectedly.

Moving forms, especially between the transfer station and the fuser entry area, can cause severe paper cuts.

CAUT0102

## Danger Notices

Danger notices make users aware of hazards that can cause serious injury or death. The following are examples of danger notices.



**DANGER**

<5> High-voltage is present. Use care while working in this area.

DANG0104



**DANGER**

<9> Laser radiation is present. Do not remove this cover when printer power is on.

DANG0108

---

## Safety Notices

### Electrical Safety

The printers are inspected and listed by recognized national testing laboratories: Underwriters Laboratories (UL) Inc. in the U.S.A., Canadian Standards Association (CSA) in Canada, and TUV Rheinland. Listing of a product by a national testing laboratory indicates that the product is designed and manufactured in accordance with national requirements intended to minimize safety hazards. Remember, however, that this product operates under conditions of high electrical potentials and heat generation, both of which are functionally necessary.

**Note:** In the U.S.A. and Canada, this product is equipped with a required, country approved plug for the user's safety. Use it in conjunction with a correctly grounded receptacle. In all other countries, the power cable is supplied without a plug. Provide the appropriate plug and compatible receptacle. Understand the electrical standards for your country, and use only an approved plug. Your IBM marketing representative has information on the voltage requirements in your country.

SAFE00ES

### Fire Safety

Because the forms and toner used in the printer can burn, you should take normal precautions to prevent fire. These precautions include common-sense measures, such as keeping potentially combustible materials (for example, curtains and chemicals) away from the printer, providing adequate ventilation and cooling, limiting unattended operation, and having trained personnel available and assigned to the printer.

SAFE00FS

### Lightning Safety

To avoid personal risk, do not install or reconfigure a communication port or a teleport during a lightning storm.

SAFE00LS



## LASER SAFETY

The printers comply with the performance standards set by the U.S. Food and Drug Administration for a Class 1 Laser Product. This means that these printers belong to a class of laser products that does not produce hazardous laser radiation in customer access areas. This classification was accomplished by providing the necessary protective housings and scanning safeguards to ensure that laser radiation is inaccessible or within Class 1 limits.

There are various tool-operated machine covers that should be moved, removed, or replaced only by trained service personnel. There are no operator controls or adjustments associated with the laser.



<23> Using controls, making adjustments, or performing procedures other than those specified herein may result in hazardous radiation exposure.

No operator maintenance is required to keep the product in compliance as a Class 1 Laser Product. No adjustments that affect laser operation or power are accessible to the operator.

The following label is located within the front cover of the printer:

**Caution!**  
Laser radiation when open.  
Avoid exposure to beam.

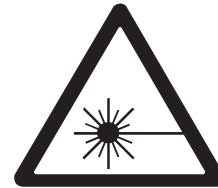

For World Trade printers, the following label is applied next to the above label:

CLASS 1 LASER PRODUCT  
LASER KLASSE 1  
LUOKAN 1 LASERLAITE  
APPAREIL A LASER DE CLASSE 1

SAFE00LX

The laser used in the InfoPrint 3000 complies with IEC 825-1 and EN 60825. The printer is a Class 1 Laser Product that contains five enclosed Class IIIb InGaAsP lasers with peak power of 10 milliwatts and a wavelength of 635 nanometers. Contained within the printhead, the lasers form scanning beams focused at the photoconductor.

## ENVIRONMENTAL INFORMATION

IBM has established a procedure by which used photoconductor drums can be returned to IBM. Specific instructions and a mailing label appear in the box in which the photoconductor drum is shipped. Third-party servicing companies and customers who are not using IBM service are encouraged to use those procedures. Postage is paid by IBM. Customers using IBM service should have their drums returned by the service representative.

The photoconductor drum may be subject to special disposal requirements in your area. Customers should consult local disposal regulations if they elect not to use the return procedure offered by IBM.

SAFE00E1

---

## Preface

This publication is for the InfoPrint 3000 Type 3300 Model ES1 and InfoPrint 3000 Models ED1/ED2 Advanced Function Printers. You will find the terms InfoPrint 3000, Model ES1, and Models ED1/ED2 used throughout this document.

This publication explains how to operate and maintain the InfoPrint 3000 printers, including the following models:

- ES1
- ED1/ED2

---

## About This Book

This publication contains the following sections:

- “Chapter 1. Introduction” on page 1 contains an overview of the printer.
- “Chapter 2. Operator’s Overview” on page 9 describes the operator’s role in using and maintaining the printer.
- “Chapter 3. Functional Areas” on page 15 describes the parts of the printer, including its switches, controls, and Display Touch Screens.
- “Chapter 4. Using the Display Touch Screen” on page 33 describes and how to use the Display Touch Screen.
- “Chapter 5. Task Summary” on page 43 summarizes the functions available from the Display Touch Screen pull-down menus.
- “Chapter 6. Operator Responsibilities” on page 55 contains step-by-step instructions for performing operator tasks.
- “Chapter 7. Ordering and Replacing Supplies” on page 175 contains step-by-step instructions for ordering and replacing supplies for the printer.
- “Chapter 8. Configuring the System” on page 217 contains information and step-by-step instructions for configuring the printer, the host attachments, and the pre-processing and post-processing device interfaces; the chapter also describes how to define forms for the printer.
- “Chapter 9. Print Quality and Problem Solving” on page 265 contains information about solving common problems that may occur during printer operation.
- “Chapter 10. Responding to Messages” on page 271 contains information about messages and codes you may see on the printer Display Touch Screen and on the Display Touch Screen windows.
- “Glossary” on page 297 defines terms used in the InfoPrint 3000 library.

---

## How to Use This Book

Depending on your level of knowledge about the printers, you may need to use some chapters more than others:

- **New Operators**

If you have little experience with the printers, begin with the following chapters:

- “Chapter 2. Operator’s Overview” on page 9, which describes the operator’s role in using and maintaining the printers.
- “Chapter 3. Functional Areas” on page 15, which describes the parts of the printer, including its switches, controls, and Display Touch Screens.
- “Chapter 4. Using the Display Touch Screen” on page 33, which describes and how to use the Display Touch Screen.
- “Chapter 5. Task Summary” on page 43, which summarizes the functions available from the pull-down menus.

- **All Operators**

If you are experienced with the printers, you probably will not need to refer to this guide for routine procedures. However, this guide may be helpful when you are handling unusual tasks or problems.

The following chapters are organized for easy reference:

- “Chapter 4. Using the Display Touch Screen” on page 33
- “Chapter 6. Operator Responsibilities” on page 55
- “Chapter 9. Print Quality and Problem Solving” on page 265
- “Chapter 10. Responding to Messages” on page 271

---

## Terminology

For definitions of terms used in this publication, as well as other publications in the printer library, see the “Glossary” on page 297.

---

## Notation Conventions

The following notation conventions are used throughout this publication:

- Words that appear in messages on a Display Touch Screen window are shown in COMPUTER print. For example:

CHANGE DEVELOPER MIX

- The words **SELECT** and **SELECTING** (all capital, bold print) refer to the act of touching the touch sensitive Display Touch Screen as though you were pressing a switch, choosing an option, or entering data.
- Words that identify switches, indicators, levers, and Display Touch Screen window names that you will use are shown in **bold** print. For example:

Press the **Ready** switch.

**SELECT** the **Configure Printer** procedure window on the Display Touch Screen.

- New terms are *italicized* where the term is first defined in the publication. For example:

The term *forms path* refers to the entire route that the forms travel.

---

## Pictorial Conventions

Most artwork in this publication shows a InfoPrint 3000 Model ES1 printer.

---

## InfoPrint 3000 Library

The following additional InfoPrint 3000 publications are available:

- *InfoPrint 3000 Introduction and Planning Guide*, G544-5563, summarizes the InfoPrint 3000 functions and describes how to plan for a successful installation.
- *Forms Design Reference for Continuous Forms Advanced Function Printers*, G544-3921, describes the characteristics of forms and special-use media, and describes their effects on printer's performance
- *IPDS Handbook for Printers That Use the Advanced Function Common Control Unit*, G544-3895, which contains technical information about the host-to-printer data stream, and exception reporting.
- *InfoPrint 3000 Maintenance Information Manuals*, IBM Part Number 24L4856, which contain technical information about maintaining and repairing the printers.

---

## Related Publications

An extensive listing of available publications is included in *Advanced Function Presentation: Printer Information*, G544-3290. For more information about Advanced Function Presentation, refer to *Guide to Advanced Function Presentation*, G544-3876.

Contact your IBM marketing representative for information concerning either the printer, its manuals, or its associated licensed programs.



---

## Summary of Changes

The following list is a summary of the changes made in this edition:

- Miscellaneous changes were made to Chapter 1 and Chapter 3.
- Miscellaneous changes were made to Chapter 6.
- The Description and Value Option for PQE Boldness in Table 25 on page 258, Table 24 on page 251, and Table 16 on page 221 were updated.
- One of two forms identification worksheets in Chapter 8 was deleted.
- Miscellaneous changes were made to Table 15 on page 177.
- Deletions were made in “Customer-Replaceable Supply Items” on page 177.
- The Toner Yield Calculations appendix was deleted.





---

## Chapter 1. Introduction

### Chapter Overview

This chapter reviews the characteristics of the IBM InfoPrint 3000, including the following models:

- ES1
- ED1/ED2

---

## System Characteristics

Table 1 on page 2 summarizes the specifications for the various printers in the InfoPrint 3000 family.

Table 1. InfoPrint 3000 Printer Specification Summary

Model	Mode	Resolution (DPI)	Print Speed (IPM)	Basis Paper Weights		Forms Width		Forms Length	
				g/m <sup>2</sup>	lbs	Min. mm (in.)	Max. mm (in.)	Min. mm (in.)	Max. mm (in.)
ES1	Simplex	480 <sup>1</sup> , 600 <sup>1</sup> 480/600 <sup>2</sup>	112/172 <sup>3</sup>	60-160	16-42	204 (8)	457 (18)	76.2 ± 0.3 (3.0 ± 0.013)	356 ± 0.3 (14.0 ± 0.013) <sup>8, 9</sup>
ED1/ED2	Duplex <sup>4</sup>	480 <sup>1</sup> , 600 <sup>1</sup> 480/600	224/344 <sup>3</sup>	60-105	16-28	229 (9)	457 (18)	76.2 ± 0.3 (3.0 ± 0.013)	356 ± 0.3 (14.0 ± 0.013) <sup>8, 9</sup>
	Dual Simplex <sup>4</sup>	480 <sup>1</sup> , 600 <sup>1</sup> 480/600	112/172 <sup>3</sup>	60-160	16-42 <sup>7</sup>	204 (8)	457 (18)		

**Notes:**

1. Standard resolution (specify feature).
2. Optional feature.
3. Print Speed stated in 1-up mode/2-up mode. (See notes 5 and 6 for more information.)
4. The Print speed for Duplex is the total system speed (2 printers). The Print speed for dual simplex lists individual printer speed (either Printer 1 or Printer 2).
5. 1-up mode (assuming an 8½-inch length page, measured in the forms process direction).
6. 2-up mode (assuming an 11-inch length page, measured in the forms process direction).
7. The maximum paper weight for duplex printers running in simplex mode should be 160 g/m<sup>2</sup> (42 lb).
8. Maximum form length is 356 ± 0.3 mm (14 ± 0.013 in.) when used with the on-board stacker.
9. Maximum form length is 711 ± 0.3 mm (28 ± 0.013 in.) when used with preprocessing and postprocessing devices.

**Note:** The InfoPrint 3000 operates in simplex and duplex mode, depending on the model selected. (Model ES1 operates only in simplex mode.)

An Advanced Function Common Control Unit (AFCCU) controls the printing system and is attached to the second printer engine in the configuration. The AFCCU is based on the IBM RISC technology and includes an Extended Graphics Adaptor (XGA) touch-screen monitor that is used as a Display Touch Screen.

Two preprocessing/postprocessing device interfaces (one in each printer), are provided on Models ES1 and ED1. This allows input capabilities and output capabilities beyond the standard forms input source and output stacker in the system printers. All other models are equipped with one preprocessing/postprocessing device interface as standard equipment. Your company can purchase additional interfaces.

---

## Printer Characteristics

The InfoPrint 3000 printers are nonimpact, all-points-addressable printers. The printers each use a laser, electrophotographic print technology, and Advanced Function Presentation (AFP) licensed programs to create high-quality text and graphic printer output.

The printers use continuous-forms in a variety of sizes, styles, and weights, including preprinted forms and some adhesive labels.

**Note: Duplex mode does not support printing on adhesive labels.**

After printing, the forms may be stacked in the printer stacker or processed by an optional postprocessing device.

Nonimpact printing, when combined with all-points addressability, allows graphics and many different type sizes and styles to appear on a single page. The printers can be used for text, image, graphic, optical character recognition (OCR), and bar-code printing. Text, images, and electronic overlays can be placed at any defined point on the page areas on which the printers can print.

---

## System Components

### *Model ED1*

This model includes:

- Printer engine
- Printer Utility Module (PUM). This unit includes:
  - Operator alert assembly
  - Power control panel
  - System interconnection electronics
  - Preprocessing/postprocessing device interfaces

### *Models ES1 and ED2*

These models include:

- Printer engine
- Advanced Function Common Control Unit (AFCCU), which includes:
  - Operator alert assembly
  - Power control panel
  - IBM RISC technology processor
  - XGA touch-screen Display Touch Screen
  - System interconnection electronics and cables
  - Preprocessing/postprocessing device interfaces

### *Model ED2*

This model also includes:

- Buffer/Flipper Unit.

This unit guides the paper path from the first printer to the second printer in this dual printer configuration. The unit allows the forms to take the following paths from the first printer to the second printer:

  - Straight through path (inline) with 180° inversion
  - Left 90° path with 180° inversion
- Urge unit

This power-driven roller assembly is on the floor in the forms input area of the second printer of the system; the continuous forms are threaded through it. It assists in feeding forms from the Buffer/Flipper Unit under the printer into the tractor feed area of the printer.

---

## Duplex Printing Applications

The following configurations support *Duplex* (double-sided) printing.

Duplex printing is achieved by arranging both a Model ED1 and a Model ED2 in series, separated by a Buffer/Flipper Unit. The first printer in the paper path prints one side of a form. The forms then exit the printer through a Buffer/Flipper Unit, which inverts them before threading them through the second printer. The second printer in the paper path prints the other side of the form.

This publication calls the first printer Printer 1 and the second printer Printer 2. Allowable printer system configurations are inline (see “Inline Configuration for Duplex” on page 6), or a left 90° angle (see “Left Angle Configuration for Duplex” on page 7). Only a Buffer/Flipper Unit may be between Printer 1 and Printer 2, but no preprocessing or postprocessing devices.

The forms path can be:

- From the forms input area of Printer 1 through to the output stacker of Printer 2
- From the forms input area to a postprocessing device at the output of Printer 2
- From a preprocessing device ahead of Printer 1 through to a postprocessing device at the output of Printer 2.

Both printers in the configuration attach to a host system through the AFCCU. The AFCCU controls both printers simultaneously and is physically attached to Printer 2 in the configuration.

---

## Simplex and Dual Simplex Printing Applications

The configuration that is shown in “Left Angle Configuration for Dual Simplex” on page 8 supports *simplex* (single-sided) printing in the Dual Simplex mode on selected models (see Table 1 on page 2). Both printers in the configuration can run independent simplex applications. The forms path would start at the forms input area or preprocessing device and proceed through to either the printer output stacker or to a postprocessing device.

When the printing system is configured as dual simplex and one of the printers is inoperable, the remaining printer can run independently so long as power and connection to the control unit are maintained.

Alternatively, forms can remain threaded continuously through both printers in a duplex physical configuration, but with printing occurring in simplex mode. Printing occurs on only one printer, while the other printer processes blank pages.

**Note:** Each printer can have its own set of preprocessing and postprocessing devices.

Both printers in the configuration attach to a host system through the AFCCU. The AFCCU controls both printers independently and is physically attached to Printer 2 in the configuration.

---

## Inline Configuration for Duplex

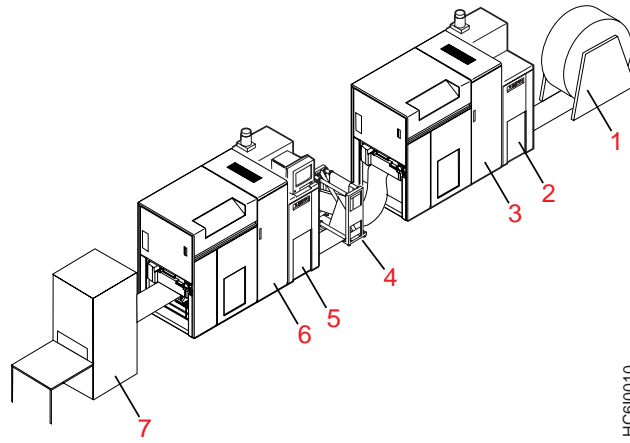

HC610010

- 1 Optional preprocessing device
- 2 Printer Utility Module (PUM) attached to Printer 1
- 3 Printer 1
- 4 Buffer/Flipper Unit
- 5 AFCCU attached to Printer 2
- 6 Printer 2
- 7 Optional postprocessing device

---

## Left Angle Configuration for Duplex

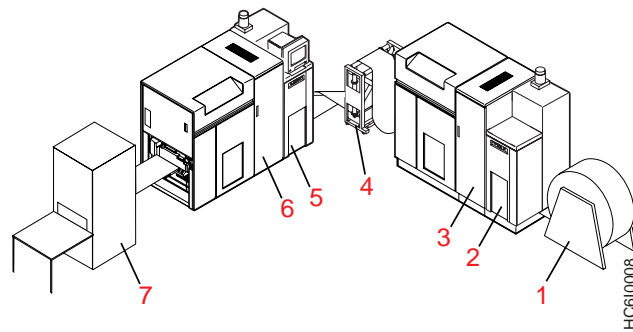

- 1 Optional preprocessing device
- 2 Printer Utility Module (PUM) attached to Printer 1
- 3 Printer 1
- 4 Buffer/Flipper Unit
- 5 AFCCU attached to Printer 2
- 6 Printer 2
- 7 Optional postprocessing device

---

## Left Angle Configuration for Dual Simplex

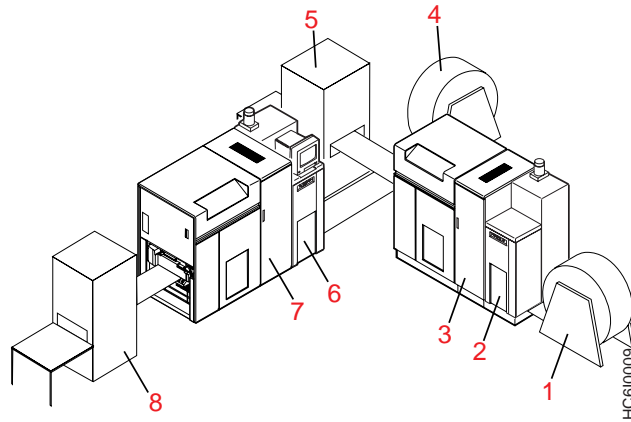

- 1 Optional preprocessing device for Printer 1
- 2 Printer Utility Module (PUM) attached to Printer 1
- 3 Printer 1
- 4 Optional preprocessing device for Printer 2
- 5 Optional postprocessing device for Printer 1
- 6 AFCCU attached to Printer 2
- 7 Printer 2
- 8 Optional postprocessing device for Printer 2



## Chapter 2. Operator's Overview

### Chapter Overview

This chapter provides an overview of the operator tasks and the general operation of the printer.

## Operator Responsibilities

Table 2 summarizes the responsibilities of the operator.

Table 2. Operator Responsibilities

What to Do:	When to Do It:	Where to Find More Information:
Power on/off the printer and enable/disable attachments	As necessary	"Controlling the System Power" on page 56 "Enabling and Disabling Attachments" on page 63
Clean all functional areas of the printer	<ul style="list-style-type: none"> <li>Once per day</li> <li>Before and after printing adhesive labels</li> </ul>	"Cleaning the Printer" on page 88
Define and load forms	As necessary	"Defining Forms" on page 247 "Loading Forms (Simplex or Dual Simplex Mode)" on page 102 "Loading Forms (Duplex Mode)" on page 115
Thread forms (duplex mode), ensure proper form alignment, and verify side 2 printing	When loading new forms, after a power on or restart, and after any machine-detected errors	"Thread/Align Forms" on page 152. Also see "Verification Marks" on page 224.
Change mode from duplex to dual simplex, or dual simplex to duplex	As necessary	Change the "Printer Mode" using "Switching Printer Modes (Dual Simplex/Duplex)" on page 172
Empty stacker	As necessary	"Unloading the Stacker" on page 169
Check print quality and print samples	<ul style="list-style-type: none"> <li>At the start of every shift</li> <li>Before and during any important jobs</li> </ul>	"Checking Print Quality" on page 85
Adjust the print position	As necessary	"Adjusting the Print Position" on page 68
Replenish and check supplies	As indicated by messages on the Display Touch Screen of the affected printer	"Adding Fuser Oil" on page 179 "Changing the Toner Cartridge" on page 182 "Checking the Toner Collector" on page 186 "Changing the Toner Collector" on page 188 "Changing the Developer Mix" on page 191 "Checking the Fine Filter" on page 200 "Changing the Fine Filter" on page 201

Table 2. Operator Responsibilities (continued)

What to Do:	When to Do It:	Where to Find More Information:
Clear forms jams and errors	As indicated by messages on the Display Touch Screen	<p>“Recovering from a Forms Jam (Simplex Operations)” on page 121</p> <p>“Recovering from a Forms Jam (Duplex Operations)” on page 127.</p> <p>“Chapter 10. Responding to Messages” on page 271</p> <p>“Chapter 9. Print Quality and Problem Solving” on page 265</p>
Run traces	As requested by the system programmer or service representative	“Running Traces” on page 148
Change printer configuration	As requested by the system programmer or service representative	<p>“Changing the Language of Messages” on page 218</p> <p>“Configuring the Printer” on page 219</p> <p>“Configuring the Host Attachments” on page 229</p> <p>“Configuring Preprocessing/Postprocessing Devices/Interfaces” on page 241</p>
Clean the oiler belt	Once each week	“Cleaning the Oiler Belt” on page 86
Check the absorbent pad in the oil pan (if they are installed)	Once each week	“Checking the Absorbent Pad in the Oil Pan” on page 212
Order supplies	As necessary	“Ordering Supplies” on page 177
Report printer usage	End of every month	“Reporting Printer Usage” on page 146
Switch print resolution	As requested by system operator, depending on the type of job being submitted <b>Note:</b> Not all InfoPrint 3000 models have this capability.	“Switching Print Resolution” on page 174

---

## Normal Operation (Ready Status)

Before the printer can begin printing, it must be in *Ready status*. The printer is in Ready status when all of the following conditions have been met:

- The printer is powered on and ready.
- The fuser is warmed up and the printhead is ready.
- The initial microcode load (IML) sequence is complete on the system control unit.
- The Thread/Align procedure has been successfully completed for duplex mode operation.
- The transfer station and all gates are closed and latched.
- All supplies are loaded.
- No errors are present.
- Host attachments are enabled.
- All enabled preprocessing and postprocessing devices are powered on and ready.
- The **Ready** pushbutton on the Display Touch Screen main window has been selected.

When the printer is operating normally, the following happens:

- In simplex mode, forms move:
  1. From the preprocessor or forms input area
  2. Through the transfer station and fuser
  3. Into the stacker or postprocessor area.
- In duplex mode, forms continue:
  1. Past the stacker area of Printer 1 through the Buffer/Flipper Unit
  2. Into the Urge Unit in the forms input area of Printer 2, through the transfer station and fuser
  3. Into the stacker or postprocessor area of Printer 2.
- If you are using the on-board stacker, the stacker table slowly lowers as it fills.
- The word **Receiving** appears on the Display Touch Screen. When **Receiving** is on the screen, data is being received from the controlling computer system.
- The Display Touch Screen windows present messages.

---

## Operator Intervention (Not Ready Status)

When normal operation is interrupted, the printer goes into a *Not Ready* status. **SELECTING** the **Stop** pushbutton on the Display Touch Screen window can cause a Not Ready status.

In addition, whenever the printer detects an Out of Supplies, Intervention Required, or Printer Error condition, it places itself in Not Ready status. An error message also appears on the Display Touch Screen.

- **Out of Supplies** messages indicate that the printer needs basic supplies service. For some supplies, you can temporarily bypass this message and continue processing; other supplies require you to replace them immediately.
- **Intervention Required** messages indicate that the printer needs basic service that involves handling forms or checking on mechanical conditions, such as an open gate. You must handle all messages of this type before printing can continue.
- **Printer Error** messages indicate that the printer or the control unit has a hardware problem, such as a forms jam or a component failure. Processing stops so that you can attempt to correct the problem, or, if necessary, call for service. You can postpone action for some messages of this type; others you must handle immediately. Some printed pages may be lost or damaged because of printer errors.

See “Chapter 10. Responding to Messages” on page 271 for more information about handling messages. See “Chapter 7. Ordering and Replacing Supplies” on page 175 and “Chapter 6. Operator Responsibilities” on page 55 for more information about specific recovery procedures.

---

## Service Call Procedure

Use this procedure only when you have tried all of the operator actions that are described in the error message or listed in this book.

1. Collect information about the printer system, including the machine type, model number, and serial number. This information is on a label (1) behind the center front cover, above the toner cartridge, on the diagonal frame of the transfer station. You will be asked for this information when you place the service call.

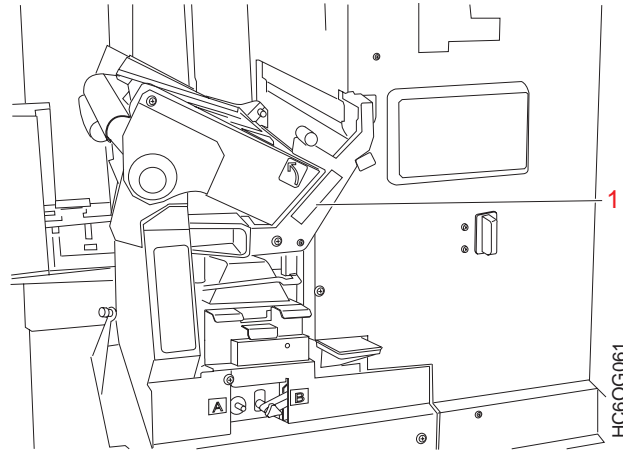

2. Collect information that is related to the problem. The service representative always needs the following information:
  - The number and exact text of each message listed in the order of their appearance on the Display Touch Screen
  - A description of the forms that are used (size, weight, adhesive labels, and preprinted forms).

Also, the following optional information may be useful:

- A description of the application that was running
  - A description of the operating environment
  - A summary of all the operator actions that were taken
  - Print samples.
3. Follow your site procedures for reporting problems. For example, you may need to notify the shift supervisor or the system programmer before you request a service call.



---

## Chapter 3. Functional Areas

This chapter describes the forms path of the printer. It also provides a graphic overview of the functional areas of the printer, which include:

- Advanced Function Common Control (AFCCU) area
  - Operator alert area
  - Power control panel
  - Display Touch Screen

**Keep In Mind:**

1. The AFCCU is physically attached to a simplex printer or Printer 2 in a duplex or dual simplex configuration.
  2. The Printer Utility Module (PUM) is physically attached to Printer 1 in a duplex or dual simplex configuration. Except for a Display Touch Screen, the PUM is identical to an AFCCU frame from your perspective.
- Developer area
  - Forms input and transfer station area
  - Printer control panel
  - Transfer station control lever
  - Puller control lever
  - Fuser entry area
  - Stacker area, stacker control panel, and forms length and width controls
  - Rear service area.

---

### Forms and the Forms Path

*Form* refers to pages on which the printer can print. Forms can be blank paper, preprinted paper, adhesive labels, cards, or any other printable material that meets the required specifications. *Paper* is a specific fiber-based material that is used for forms.

The term *forms path* refers to the entire route that forms travel while they are being processed. The forms path begins in the forms input area and ends in the stacker area. Figure 1 on page 16 shows the forms path for a simplex printer and the major elements within the printer engine. Note that the path looks a bit different if you use preprocessing or postprocessing devices attached to your printer.

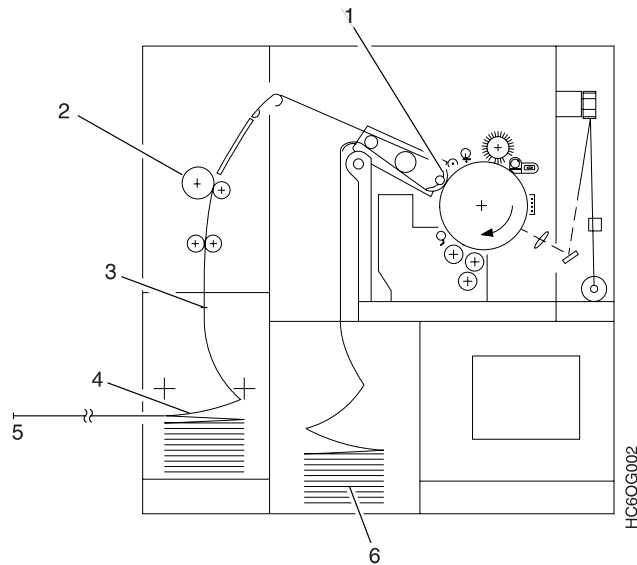

Figure 1. Forms Path Through a Printer Engine

For simplicity, Figure 1 shows a generalized forms path when a printer is being used for simplex printing and is using boxed fan-fold forms.

- 1 Transfer Station
- 2 Fuser
- 3 Stacker Pendulum
- 4 Output Stacker Area
- 5 Postprocessor
- 6 Input Forms Area

- Note the following differences when a printer runs in dual simplex mode, uses forms from a preprocessing device, and has a postprocessing device installed and enabled:
  - Forms enter from the right *under* the printer to the urge unit and then move up through the Forms Input area (6).
  - The stacker is disabled, and forms exit the printer to the left directly to the postprocessing device (5).
- Note the following differences when you use a printer for duplex or simplex printing:
  - If the printer is Printer 1 in the configuration, the stacker is disabled. The forms exit the printer to the left from the Output Stacker Area (4) directly to the Buffer/Flipper Unit.
    - If a preprocessing device is installed, the forms enter from the right under the printer to the urge unit and then move up through the Forms Input area (6).
  - If the printer is Printer 2, the forms enter from the right under the printer through an Urge Unit that is placed on the floor in the Forms Input area (6). The forms then move up through the Forms Input area.
    - If a postprocessing device is installed and enabled, the stacker is disabled, and the forms exit the printer to the left directly to the postprocessing device (5).



---

## Control Unit Area

The Display Touch Screen, power control panel, and the operator alert assembly are in the control unit area.

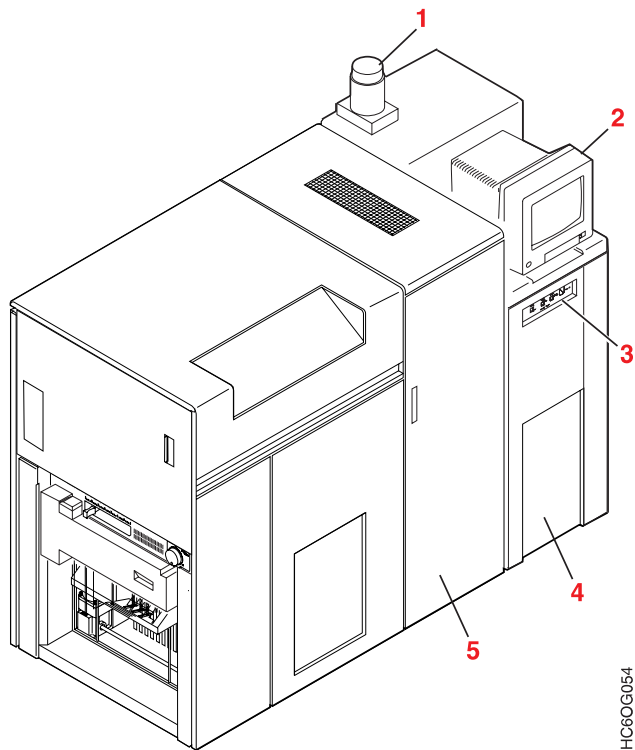

- 1 Operator Alert Assembly
- 2 Display Touch Screen
- 3 Power Control Panel
- 4 AFCCU Frame in a simplex printer or in Printer 2 of a duplex configuration or Printer Utility Module (PUM) Frame in Printer 1
- 5 Printer Engine Frame

## Operator Alert Area

The following figure shows the controls on the Operator Alert Area, which is on the base of the Operator Alert Assembly.

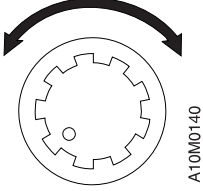
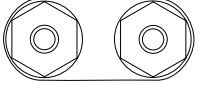
Using This Control:	Does This:
<b>Operator Alert Assembly Volume Control</b> 	Adjusts the volume of the operator alert assembly.
<b>External Connections for Customers</b> 	Provides customers with a set of external contacts to allow the hook-up of an alert signal of the customer's choice.

## Display Touch Screen

The Display Touch Screen provides you with a touch-sensitive interface to the printer. "Chapter 4. Using the Display Touch Screen" on page 33 describes it in detail.

## Power Control Panel

On Printer 1 of a duplex system, the Power Control Panel provides power control for the Printer Utility Module (PUM) frame and the printer engine. On Printer 2 of a duplex system and on a simplex printer, the Power Control Panel provides *direct* power control for the AFCCU frame and the printer engine. The Power Control Panel also provides *remote* power control for Printer 1 in a duplex printing system.

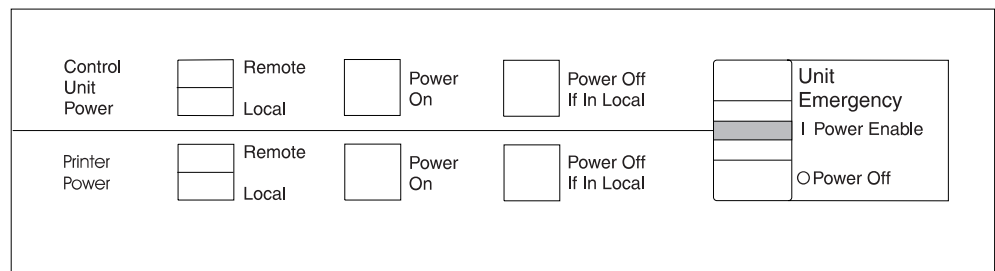

**Note:** Although the switches are labeled "Control Unit" on this panel in the PUM frame of Printer 1, these switches control the power in the PUM frame, not the AFCCU frame attached to Printer 2.

Using This Control:	Does This:
<b>Control Unit Local/Remote Switch</b>	<p>Establishes where control unit power is controlled.</p> <p><b>On Printer 1</b> - When this switch is in the Local position, the PUM is powered on and off by the <b>Control Unit Power On</b> and the <b>Control Unit Power Off if in Local</b> switches. In the Remote position, the PUM is powered on and off by Printer 2 control unit power controls.</p> <p><b>On simplex printers and Printer 2 of a duplex configuration</b> - When this switch is in the Local position, the AFCCU is powered on and off by the <b>Control Unit Power On</b> and the <b>Control Unit Power Off if in Local</b> switches. In the Remote position, the AFCCU is powered on and off by the controlling computer system.</p>
<b>Printer Local/Remote Switch</b>	<p>Establishes where printer power is controlled. When this switch is in the Local position, the printer is powered on and off by the <b>Printer Power On</b> and the <b>Printer Power Off if in Local</b> switches. In the Remote position, the printer is powered on and off by the <b>Control Unit Power On</b> and <b>Control Unit Power Off If In Local</b> switches on this panel.</p>
<b>Control Unit Power On Switch</b>	<p>Powers on the AFCCU frame or the PUM frame when the <b>Control Unit Local/Remote</b> switch is set to Local.</p>
<b>Printer Power On Switch</b>	<p>Powers on the printer when the <b>Printer Local/Remote</b> switch is set to Local.</p>
<b>Control Unit Power Off If In Local Switch</b>	<p>Powers off the AFCCU when the <b>Control Unit Local/Remote</b> switch is set to Local.</p>
<b>Printer Power Off If In Local Switch</b>	<p>Powers off the printer when the <b>Printer Local/Remote</b> switch is set to Local.</p>
<b>Emergency Power Off Switch</b>	<p><b>On Printer 1</b> - When set to Power Enable, the PUM and printer engine can be powered on by Local or Remote control. Power Off does an emergency shutdown.</p> <p><b>On simplex printers and Printer 2 of a duplex configuration</b> - When set to Power Enable, the AFCCU and printer engine can be powered on by Local or Remote control. Power Off does an emergency shutdown. All power is removed from the system.</p>
<div style="border: 1px solid black; padding: 5px;"> <p><b>Attention!</b> Using the <b>Unit Emergency Power Off</b> switch can cause loss of data and hardware problems; therefore, you should use it <b>only in an emergency</b>.</p> </div>	

---

## Developer Area

You add toner and developer mix to the printer in the developer area. Table 3 on page 21 describes the controls.

You add toner by placing a new toner cartridge (1) in the developer area next to the Printer Control Panel.

You add developer mix through the developer mix inlet (2). The developer drain lever (3), which is marked with a **B** label, opens and closes the developer drain. The developer run pushbutton (4), which is marked with an **A** label, causes new developer mix to move from the developer mix inlet into the developer.

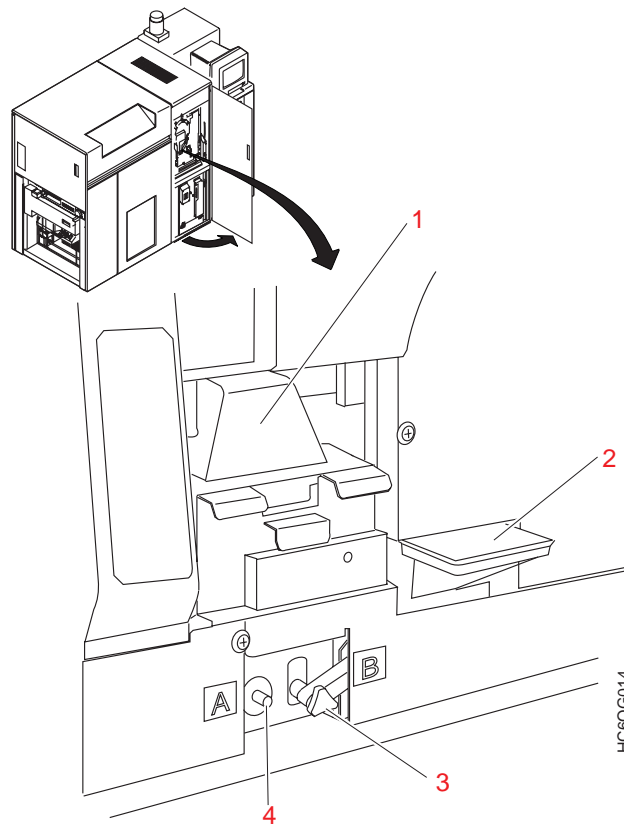

Table 3. Developer Area Controls

<b>Using This Control:</b>	<b>Does This:</b>
<p><b>Toner Cartridge</b></p> <p>1</p>	<p>Contains toner for the toner hopper.</p>
<p><b>Developer Mix Inlet</b></p> <p>2</p>	<p>Supply opening for adding developer mix to the developer.</p>
<p><b>Developer Drain Lever</b></p> <p>3</p>	<p>Starts the developer mix drain process to move developer mix from the developer into an external container for disposal.</p>
<p><b>Developer Run Pushbutton</b></p> <p>4</p>	<p>Starts the developer mix load process to move developer mix from the developer inlet into the developer; also aids in removing used developer mix from the developer.</p>

---

## Forms Input and Transfer Station Area

You load forms that are ready for processing into the printer at the forms input area. The developer mix bottle and drain hose are also in the forms input area.

In the transfer station area, print images are transferred from the photoconductor drum to the forms that are traveling through the printer. “Printer Control Panel” on page 23 describes the printer control panel in detail.

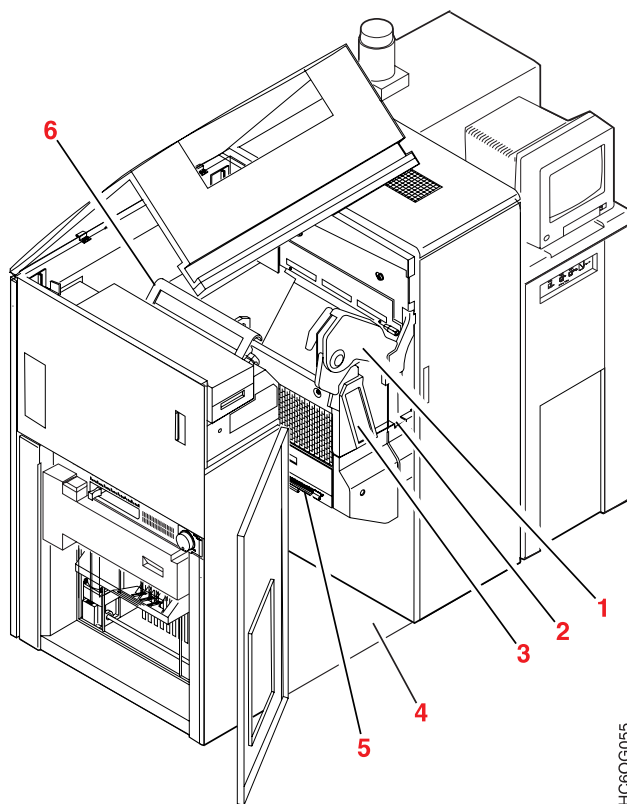

HC6OG055

- 1 Transfer station
- 2 Developer area
- 3 Printer control panel
- 4 Forms input area
- 5 Static brushes
- 6 Tension arm

# Printer Control Panel

The printer control panel is just below the transfer station. Table 4 describes its controls.

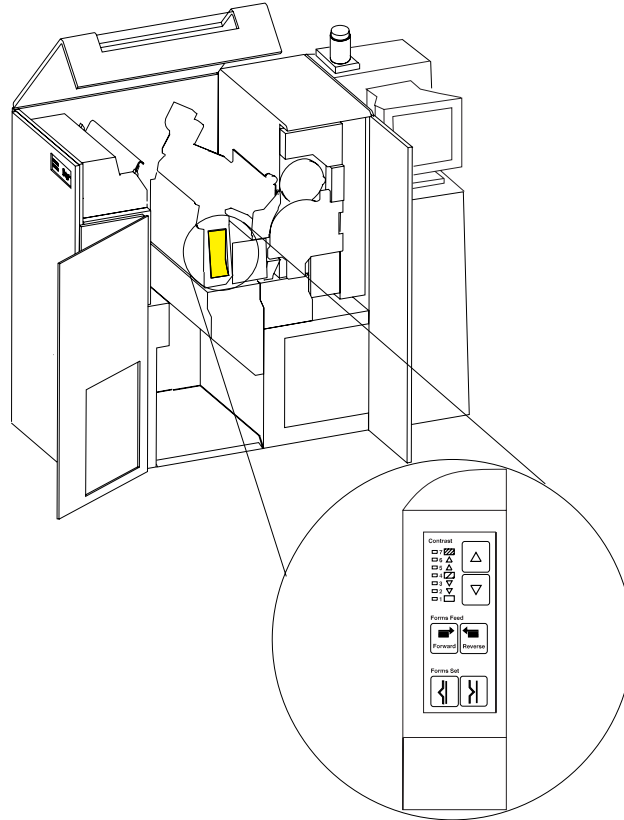

HC60G001

Table 4. Printer Control Panel

Using This Control:	Does This:
<p><b>Darker Contrast Control Key</b></p>  <p>A23O0051</p>	<p>Adjusts print contrast from lighter (1) to darker (7). The current setting is marked by an LED.</p>
<p><b>Lighter Contrast Control Key</b></p>  <p>A23O0052</p>	<p>Adjusts print contrast from darker (7) to lighter (1). The current setting is marked by an LED.</p>

Table 4. Printer Control Panel (continued)

Using This Control:	Does This:
<p data-bbox="446 275 673 300"><b>Forms Set Left Fold</b></p> 	<p data-bbox="711 275 1440 390">Indicates that the first fold perforation below the slots on the input forms guide is a left fold. If the indicator displays the opposite fold direction or no fold direction, press the appropriate key to change the setting.</p> <p data-bbox="711 394 1440 478"><b>Note:</b> Use this control only for fan-fold forms that are stacked at the printer stacker. If the control is not set correctly, the stacker jams.</p>
<p data-bbox="446 579 673 604"><b>Forms Set Right Fold</b></p> 	<p data-bbox="711 579 1440 695">Indicates that the first fold perforation below the slots on the input forms guide is a right fold. If the indicator displays the opposite fold direction or no fold direction, press the appropriate key to change the setting.</p> <p data-bbox="711 699 1440 783"><b>Note:</b> This control is used only for fan-fold forms that are stacked at the printer stacker. If the control is not set correctly, the stacker jams.</p>
<p data-bbox="446 884 673 909"><b>Forms Feed Forward</b></p> 	<p data-bbox="711 884 1440 968">Moves the forms toward the transfer station and stacker area. Forms in the forms path between the transfer station and the fuser are not fused.</p>
<p data-bbox="446 1188 673 1213"><b>Forms Feed Reverse</b></p> 	<p data-bbox="711 1188 1440 1220">Moves the forms away from the transfer station into the input bin.</p> <p data-bbox="711 1224 1440 1329"><b>Note:</b> When you use this function, it may be necessary to press the Puller Control Lever to release pressure on the forms in the fuser area. This can prevent a down condition of the tension arm and tearing or damage of the forms.</p>

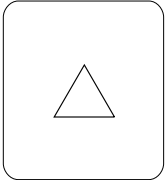
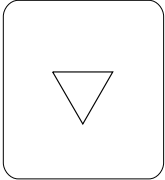
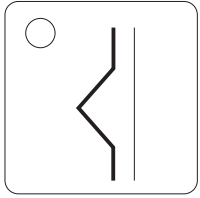
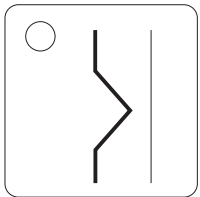
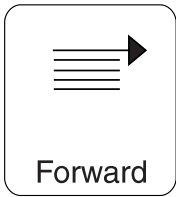
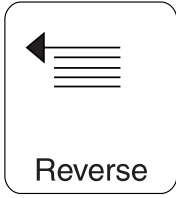

## Transfer Station Control Lever and Tractor Control Levers

The transfer station control lever and the tractor control knob are on the transfer station frame.

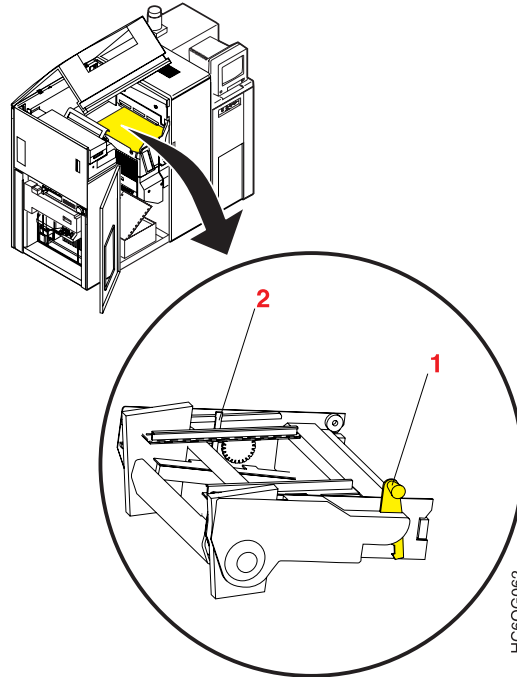

Using This Control:	Does This:
<p><b>Transfer Station Control Lever</b></p> <p>1</p>	<p>Releases the transfer station latch and opens the transfer station.</p> <p>To open the transfer station, you move the lever to the <i>left</i> and lift the transfer station in a <i>counterclockwise</i> direction.</p> <p>To close the transfer station, you lower the transfer station in a <i>clockwise</i> direction. You then move the lever to the left and press down on the transfer station to latch it in place.</p> <p>During printing, the transfer station should be firmly latched in the closed position.</p>
<p><b>Tractor Control Levers</b></p> <p>2</p>	<p>Allow you to change the distance between the front and rear tractors. When you move the levers to the left, the tractors are free to move forward or backward to the required form width. Release the lever when you have reached the correct distance.</p> <p>A scale to the right of the tractors allows you to preset the tractors to the closest approximate setting before you load the forms.</p>

---

## Puller Control Lever

The puller lever is on the left side of the input area. When you press the lever, pressure is released on the scuff and backup rollers inside the fuser area. The lever is spring-loaded, so pressure returns to the scuff and backup rollers when you release the puller lever.

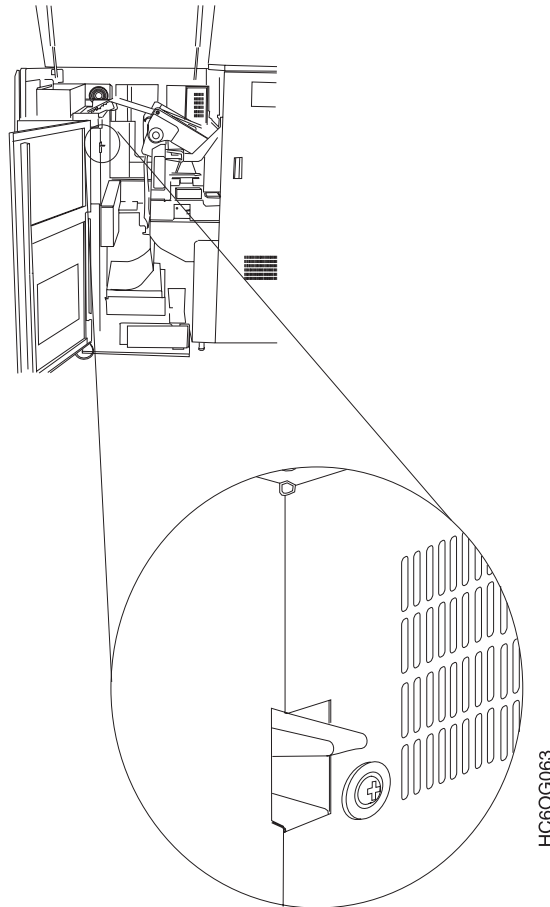

---

## Fuser Entry Area

After they receive print images, the forms pass through the fuser entry area toward the fuser.

In the fuser area, heat and pressure from the fuser heat-roll bond the print images onto the forms.

---

## Stacker Area

Printed and fused fan-fold forms leave the fuser area and are refolded in the stacker area. “Stacker Control Panel” on page 28 and “Forms Length and Width Controls” on page 30 describe the stacker area controls in detail.

**Note:** Roll-feed forms do not use the stacker area. They require a postprocessor.

The pendulum is inside the stacker area, above the stacker table. The swinging of the pendulum helps the forms to refold correctly.

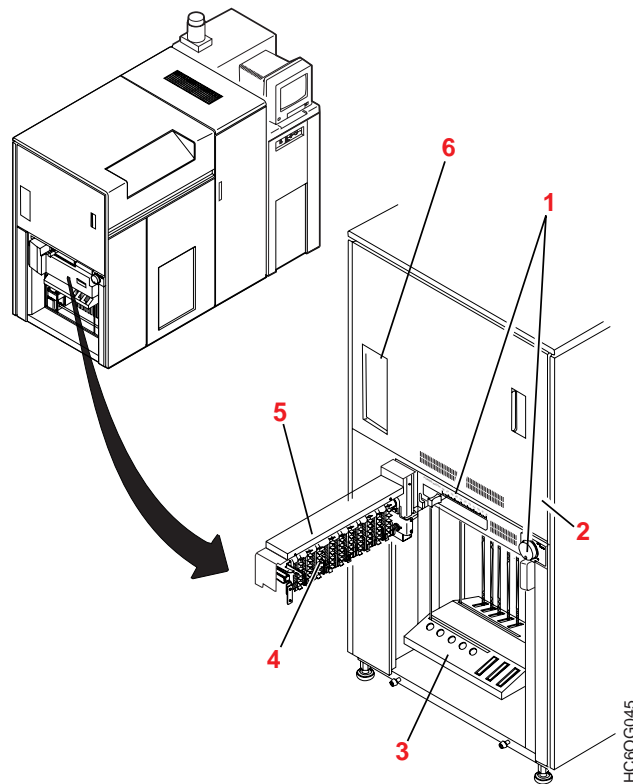

- 1 Forms length and width controls
- 2 Stacker end cover
- 3 Stacker table
- 4 Finger belts
- 5 Stacker gate (open)
- 6 Stacker control panel

## Stacker Control Panel

The stacker control panel is just above the stacker. The controls allow you to raise and lower the stacker table, stop the movement of the stacker table, advance the forms, and select the type of form being used. The panel also indicates with lights the length of the forms being used, which is set by the Forms Length Control (see “Forms Length and Width Controls” on page 30).

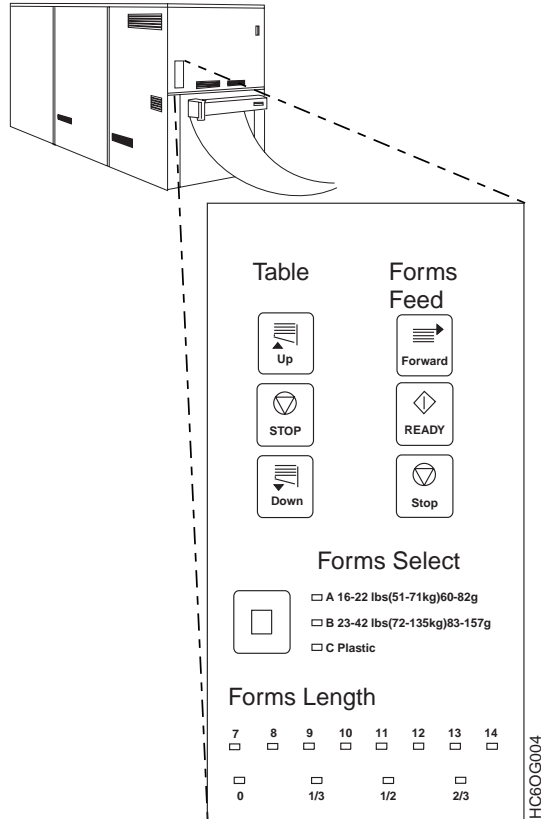

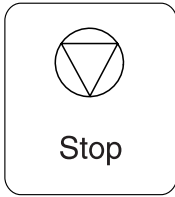
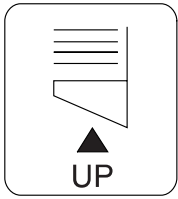
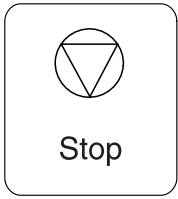
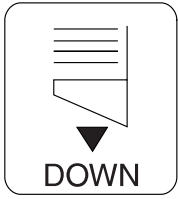
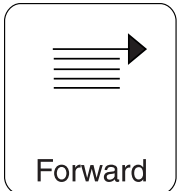
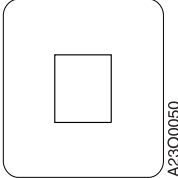
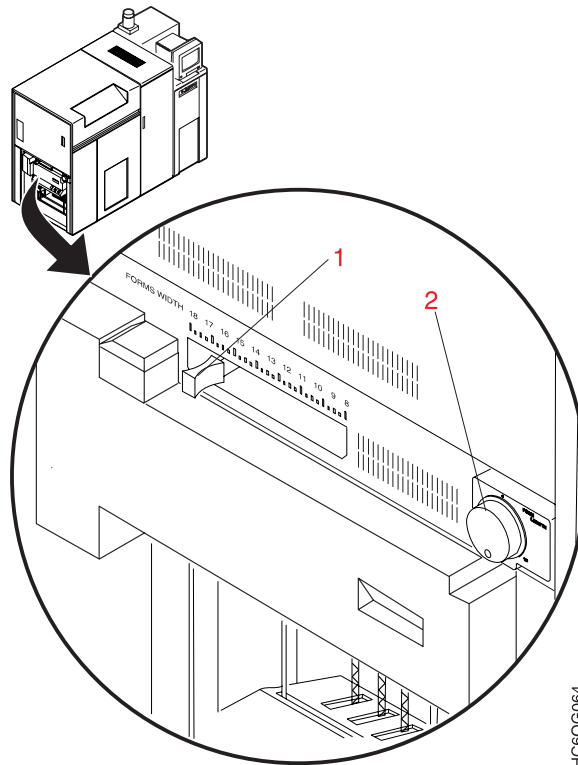

Figure 2. Stacker Control Panel

Using This Control:	Does This:
 <p>A09M0332</p>	Makes the complete system (both printers) Ready when the printing system is in duplex mode, or makes the individual printer Ready when the system is in dual simplex mode. If pages are waiting to be printed and the system or printer is online to the host, printing begins.
 <p>R4CO0108</p>	Finishes the page that is currently being printed and makes the printing system (both printers) Not Ready in duplex mode or the individual printer Not Ready in simplex mode.

Using This Control:	Does This:
 <p style="text-align: right; font-size: small;">R4CC00104</p>	Moves the stacker table up.
 <p style="text-align: right; font-size: small;">R4CC00108</p>	Stops the movement of the stacker table.
 <p style="text-align: right; font-size: small;">R4CC00105</p>	Moves the stacker table down.
<p><b>Forms Feed</b></p>  <p style="text-align: right; font-size: small;">R4CC00100</p>	<p>Advances the forms to allow them to stack with the original folds at the perforations.</p> <p><b>Note:</b> You use the NPRO pushbutton on the Display Touch Screen to advance the forms for separation.</p>
<p><b>Forms Select</b></p>  <p style="text-align: right; font-size: x-small;">A2300060</p>	<p>Sets the weight or kind of form to be used, as well as the fusing temperature and the amount of fuser oil used during printing. The current selection is indicated by an LED. Not setting <b>Forms Select</b> correctly can reduce print quality.</p> <ul style="list-style-type: none"> <li>• The <b>A</b> setting is for <b>16-22 lbs (60-82 g/m<sup>2</sup>)</b> weight forms. It should not be used for heavier weight forms.</li> <li>• The <b>B</b> setting is for <b>23-42 lbs (83-157 g/m<sup>2</sup>)</b> weight forms. It uses more fuser oil than setting <b>A</b> and should not be used for lighter weight forms.</li> <li>• The <b>C</b> setting lowers the fuser temperature and should be used when printing adhesive labels or other special composition forms.</li> </ul>

## Forms Length and Width Controls



HC6G064

Using This Control:	Does This:
<p><b>FORMS WIDTH</b></p> <p>1</p>	<p>Increases or decreases the stacker width setting. You can set this lever from 8 to 18 inches in increments of <math>\frac{1}{4}</math> inch.</p>
<p><b>FORMS LENGTH</b></p> <p>2</p>	<p>Increases or decreases the stacker length setting. You can set the forms length from 7 to 14 inches. The length increases or decreases in increments of one-third and one-half inch. You turn the knob <i>clockwise</i> to increase the forms length. You turn the knob <i>counterclockwise</i> to decrease the forms length.</p> <p>The length you set with the FORMS LENGTH knob is indicated by the LEDs on the Stacker Control Panel.</p>

## Stacker Height Control

The stacker height control is behind the front left cover. This control allows you to control the height (and weight) of the printed output stack. Raising the stacker height shortens the height of the output stack. While this reduces the weight of the output stack, it also required you to empty the stacker more often. For more information on using this control, see “Adjusting the Stacker Table Height” on page 117.

**Note:** Use this control only for fan-fold forms, not for roll-feed forms.

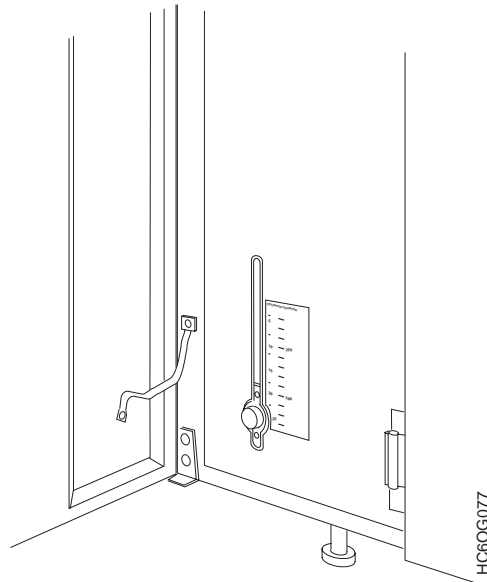

Figure 3. Stacker Height Control

---

## Rear Service Area

The toner collector, fine filter, usage meter, and fuser oil reservoir are in the rear service area. The preprocessing/postprocessing device interface cable connection area is located behind the rear cover of either the AFCCU frame or the PUM frame.

Note that the preprocessing/postprocessing device interface cable connection area is the same on the AFCCU frame of the following:

- A simplex printer
- Printer 2 of a duplex or dual simplex configuration
- Or the PUM frame on Printer 1.

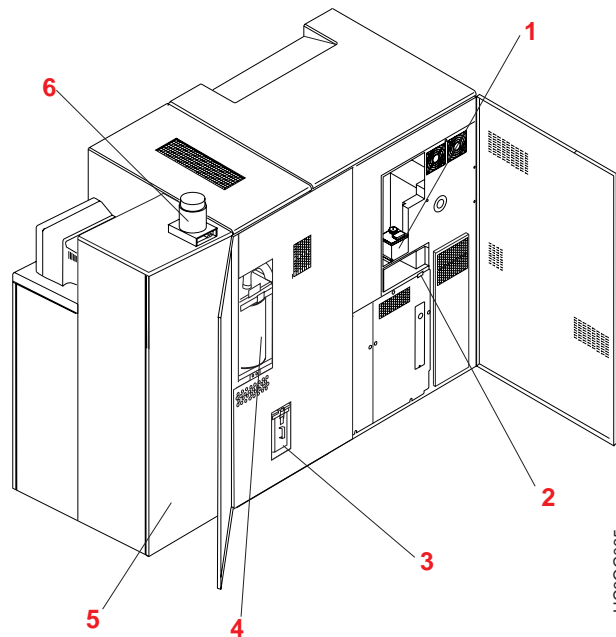

- 1 Fuser oil reservoir
- 2 Usage meter
- 3 Toner collector
- 4 Fine filter
- 5 Pre/Postprocessor device cable connection area (behind rear cover)
- 6 Operator alert assembly



---

## Chapter 4. Using the Display Touch Screen

This chapter describes the Display Touch Screen windows and their associated components. These windows are similar to those that are used in OS/2 and other graphical environments.

The Display Touch Screen is touch-sensitive. To interact with it, you touch the screen as though you were pressing a pushbutton switch, making a selection from a list, or entering data on a keyboard.

The graphics in this book that depict the Display Touch Screen do not match the actual windows in every detail. The windows on your Display Touch Screen have a title bar at the top that is not shown in this book.

---

### Using the Display Touch Screen in Duplex and Dual Simplex Modes

In duplex mode, the two printers work as one logical printer and are controlled from a single Display Touch Screen.

In dual simplex mode, each physical printer works independently of the other. The monitor has two logical Display Touch Screens, one for controlling each printer. To switch from one printer to the other, select the **Next Printer** pushbutton on the Main Window.

**Note:** Although most of the artwork in this book shows a Display Touch Screen that is in duplex mode, the simplex mode Display Touch Screen looks virtually the same.

## Display Touch Screen Windows

Figure 4 shows a sample Display Touch Screen window and its components.

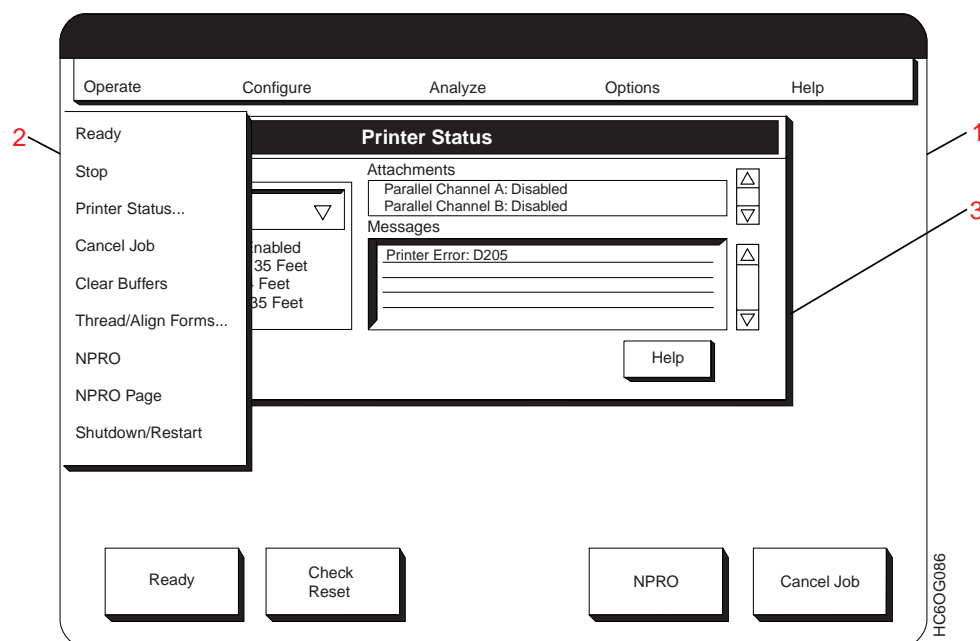

Figure 4. Display Touch Screen Window Components

### 1 Main Window

The Main Window always appears on the Display Touch Screen. All of the other pull-down menus, procedure windows, keyboard and keypad windows, and pop-up windows appear on top of it.

The Main Window contains the following:

- A Title Bar, which lists the name of the printer and the current authorization level of Key Operator or Customer Engineer.
- A Menu Bar, which lists the five pull-down menus you can use (**Operate**, **Configure**, **Analyze**, **Options**, and **Help**).
- Pushbuttons, which let you access frequently-used procedures.

**Ready/Stop** Acts as a toggle between **Ready** and **Stop**, depending on the current state of the printer or printing system. **Ready** makes the complete system (both printers) Ready when it is in duplex mode, or makes the individual printer Ready when the system is in dual simplex mode. If pages are waiting to be printed and the system or printer is online to the host, printing begins.

**Stop** finishes the page that is currently printing. It then makes the complete system (both printers) Not Ready in duplex mode, or the individual printer Not Ready in simplex mode.

**Check Reset** Informs the system that the error has been corrected and can return to the Ready status. This pushbutton is not active when the printer or printing system is in Ready mode.

<b>Next Printer</b>	Switches from one simplex printer main window to the other simplex printer main window. This pushbutton is available only in dual simplex mode.
<b>Cancel Job</b>	Lets you cancel the job currently being printed. In duplex mode, both system printers must be in a Not Ready state to cancel a job. In simplex mode, only the individual printer must be in a Not Ready state. See “Canceling a Job” on page 78 for more information.
<b>NPRO</b>	Moves forms forward through the forms path. See “Advancing Forms Using the NPRO and NPRO Page Functions” on page 75 for more information about the NPRO function.

## 2 Pull-Down Menu

A pull-down menu appears when you select a choice on the Main Window Menu Bar. The menu contains a list of functionally-grouped procedures. Figure 4 on page 34 shows the pull-down menu that you see if you **SELECT Operate** from the Main Window Menu Bar.

## 3 Procedure Window

A procedure window appears when you select a procedure from a pull-down menu. A procedure window provides you with all of the lists, options, and pushbuttons you need to accomplish a defined procedure.

Figure 4 on page 34 shows the procedure window you see when you select the **Printer Status...** procedure from the **Operate** pull-down menu.

Figure 10 on page 44 shows all pull-down menu procedures. It also shows which pull-down menu you use to access each procedure. Shading indicates the user authorization level that is required of each procedure. “Chapter 5. Task Summary” on page 43 summarizes all of the functions available from the pull-down menus.

---

## Keyboard, Keypad, and Hexpad Windows

You see a keyboard (Figure 6 on page 37), keypad (Figure 5 on page 36), or hexpad window when a procedure requires you to enter numeric or alphanumeric data. The title bar on these windows contains the same title as the procedure window.

The following function and cursor control keys are on each type of keyboard or keypad:

<b>OK</b>	Removes the keyboard or keypad window and displays the new value that you entered in the procedure window-selectable field item that called it.
<b>Clear</b>	Clears the input from the entry field if you make a mistake, and allows you to start over.
<b>Cancel</b>	Cancels any entries you have made and removes the window.
<b>Help</b>	Displays a help window that describes how the keyboard window works.
<b>Insert</b>	Acts as a toggle switch between <i>Insert</i> and <i>Overwrite</i> modes. Either the word “Insert”, or “Overwrite” appears at the right side of the entry field.

In Insert mode, characters you select are inserted at the cursor position, moving any existing characters to the right. In Overwrite mode, characters you select are “typed” at the cursor position directly over existing characters.

- Delete** Erases an existing character at the cursor position.
- Home** Moves the cursor to the beginning (the left side) of the entry field.
- End** Moves the cursor to the end (right side) of the entry field.
- Left** Moves the cursor one character space to the left.
- Right** Moves the cursor one character space to the right.
- Backspace** Erases an existing character to the left of the cursor.
- Caps** (Alphanumeric Keyboard Only) Acts as a switch to change keyboard entries from lowercase to uppercase, or uppercase to lowercase.
- Shift** (Alphanumeric Keyboard Only) Affects only the next character you enter by changing the case (upper or lower) set by the “Caps” key to the opposite case.
- Lock** (Alphanumeric Keyboard Only) Acts as a switch between locked and unlocked mode for uppercase characters, which is set by the “Caps” key.

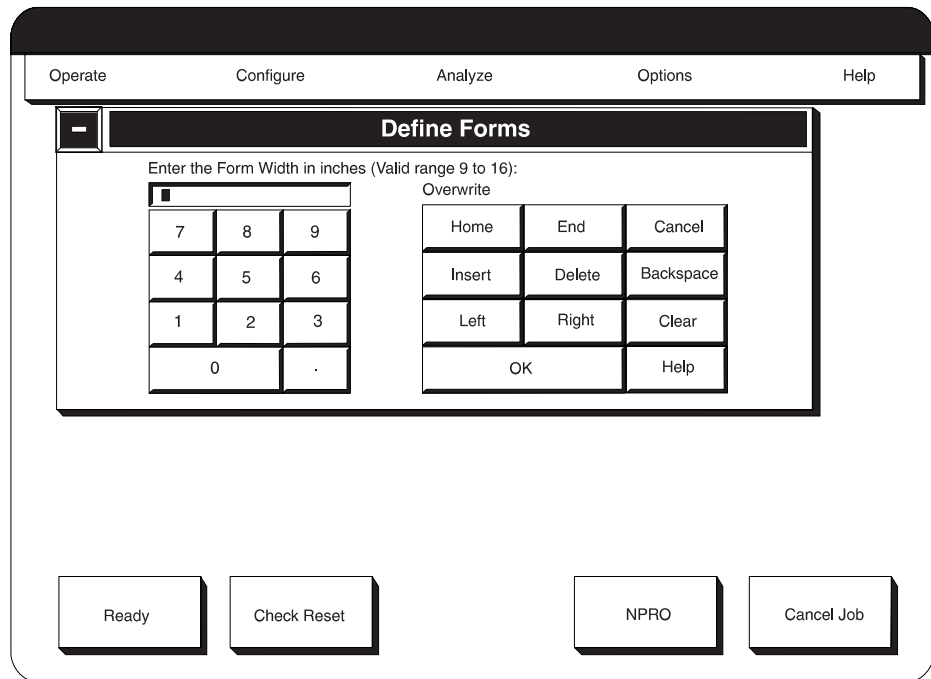

Figure 5. Numeric Keypad Window

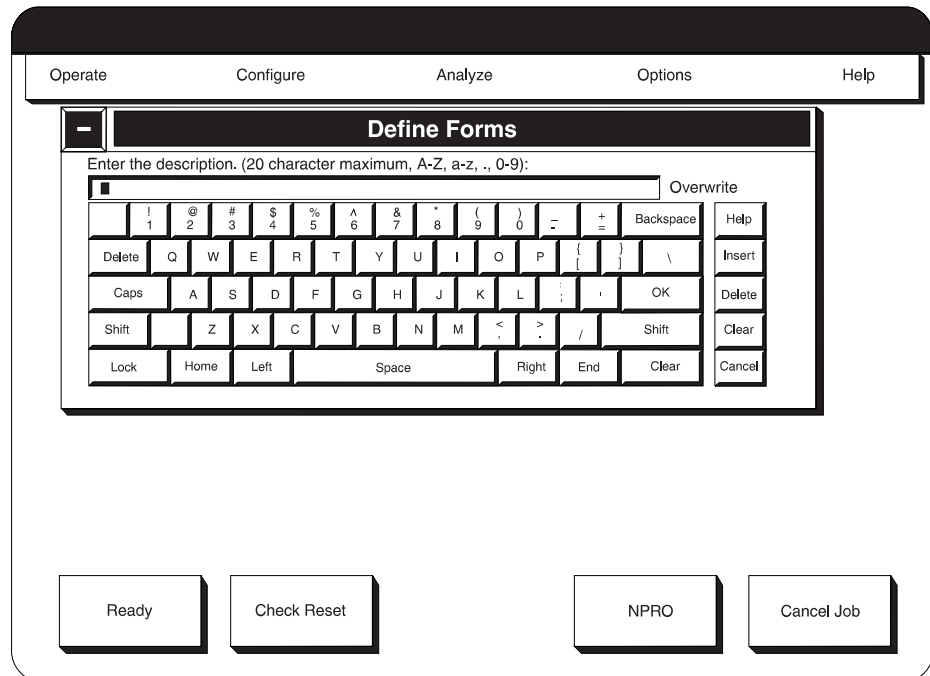

Figure 6. Alphanumeric Keyboard Window

## Selection Devices on the Display Touch Screen Windows

The following sections summarize the controls you use to interact with the printers.

### Fingertip Control

When you touch the surface of the Display Touch Screen with your finger, a small plus symbol (+) appears directly under your finger tip. Moving your finger across the surface moves the (+) symbol. Removing your finger from the surface of the monitor selects the action or item on which the (+) symbol rests.

### Pushbuttons

Pushbuttons look like three-dimensional pushbutton switches. They allow you to select a particular action, which occurs immediately. An ellipsis (...) that follows a pushbutton name means that selecting the pushbutton causes a another procedure window or a pop-up window to appear.

### Selectable Field

A *selectable* field on a procedure window or a pop-up window displays the current setting of an item that you can change. To change the setting, **SELECT** the field. A pop-up window appears containing one of the following:

- Two or more choices from which you can select.
- A selection list box with many items from which you can select. See (4) in Figure 9 on page 40 for an example of a pop-up window with a selection list box.
- A keypad or keyboard window in which you can enter a new value.

The new value you select or enter appears in the selectable field on the procedure window.

## Radio Buttons

A radio button on the Display Touch Screen consists of a diamond and some associated text. Radio buttons allow you to choose between two or more responses or actions. The diamond is highlighted for the active choice. You are allowed only one choice within any set of radio buttons.

## Scroll Bar

Some procedure windows and pop-up windows contain a selection list box that has multiple selections. Many selection list boxes have a vertical scroll bar on the right side of the box. This bar allows you to view additional unseen information in the box.

## Inactive Items

All pushbutton text, selection list items, and pull-down menu procedures appear regardless of whether they are currently selectable. Not all items are available on all printer models. Items that you cannot select are *grayed out*, which means the text is faint but readable.

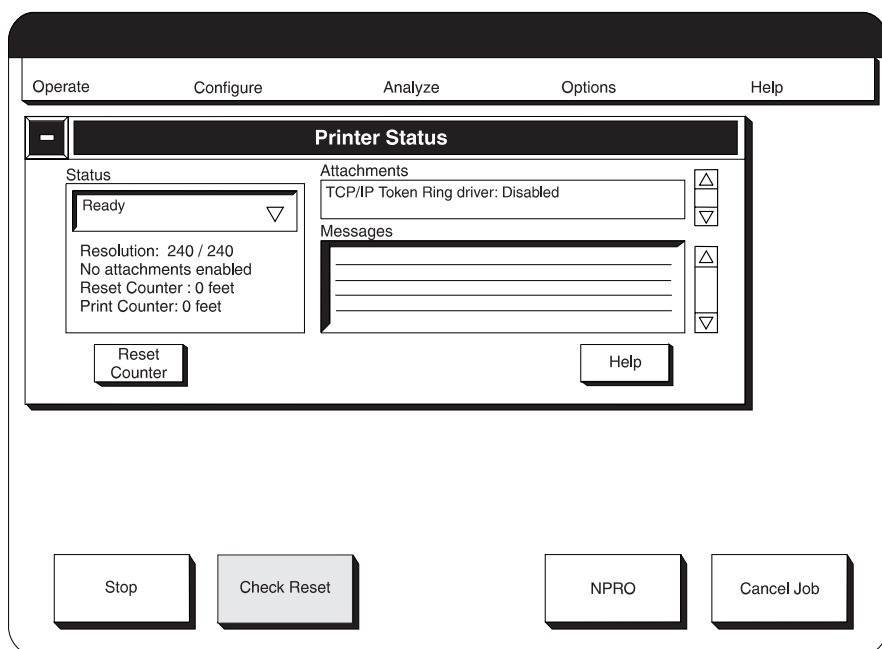

Figure 7. Grayed Out Check Reset Pushbutton

For example, when a printer is in the Ready state, the **Check Reset** pushbutton is grayed out, but it is not grayed out when a printer is in the Not Ready state.

**Note:** Except for the figure above, none of the selection items, pull-down menu procedures, or pushbuttons that would normally be grayed out on a pull-down menu or procedure window are shown that way in any of the window figures in this publication.

## Control Procedures

### System Menu

The System Menu Symbol (1) is a horizontal line within a pushbutton on the left side of the Title Bar on all procedure windows (2). When you select this symbol, a pull-down menu (3) appears directly under the symbol.

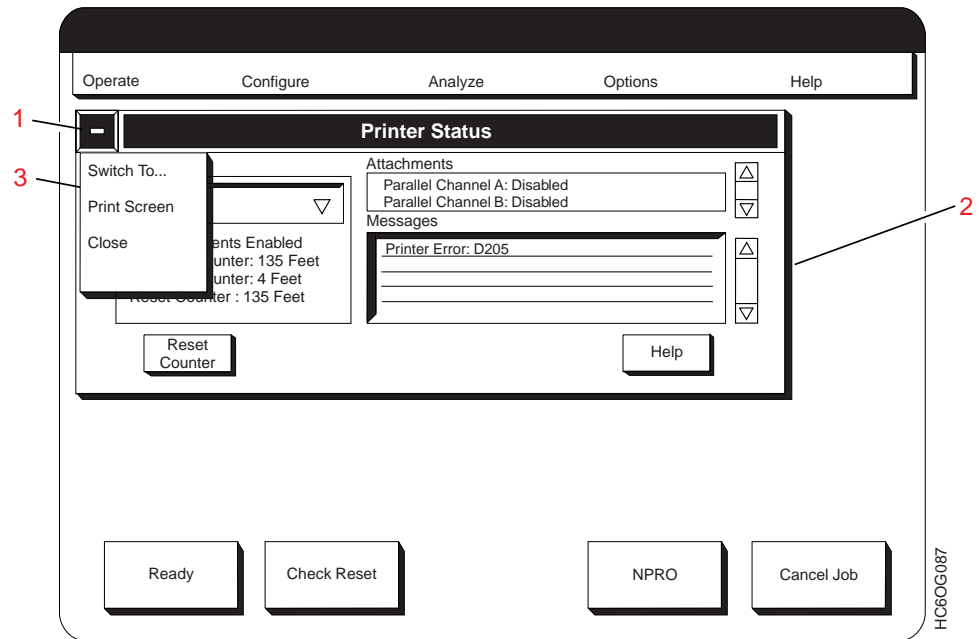

Figure 8. System Menu Symbol - Pull-Down Menu

There are three actions on the pull-down menu from which you can choose:

#### Switch to...

Displays a pop-up window that lists all of the procedures that are currently open (for example, see (4) on Figure 9 on page 40). Selecting any procedure name from the list moves the window for the procedure to the front.

#### Print Screen

Prints the screen if all installed host attachments are disabled.

**Close** Closes the procedure (the same as if you had selected the **Close** on the procedure window).

### Multiple Procedures

You can have any number of procedures active at one time. However, only five procedures can *appear* on the Display Touch Screen at one time. To switch back and forth between the procedures on the Display Touch Screen, select the title bar of the procedure you want. If there are more than five procedures that are active, you can still use the procedures that have been pushed off the display. Do this by selecting the **Switch to...** option from the System Menu pull-down menu.

In duplex or simplex mode, multiple copies of the same procedure cannot run at the same time. Once a procedure is started, the menu bar item that started the

procedure will not start another procedure of the same type. The window will display the procedure window at the front of the cascade. However, in dual simplex mode the same procedure can be open and active on both Printer 1 and Printer 2 Display Touch Screen windows.

Figure 9 shows:

- 1 The Main Window
- 2 Four of the five maximum procedure windows
- 3 The System Menu pull-down menu
- 4 The **Switch to** pop-up window, which lists all open procedures
- 5 A symbol that indicates that more than five procedures are open.

Use the scroll bar to the right of the **Switch to** pop-up window to view the names of additional open procedures. When you select a procedure, the procedure window appears at the front of the cascade.

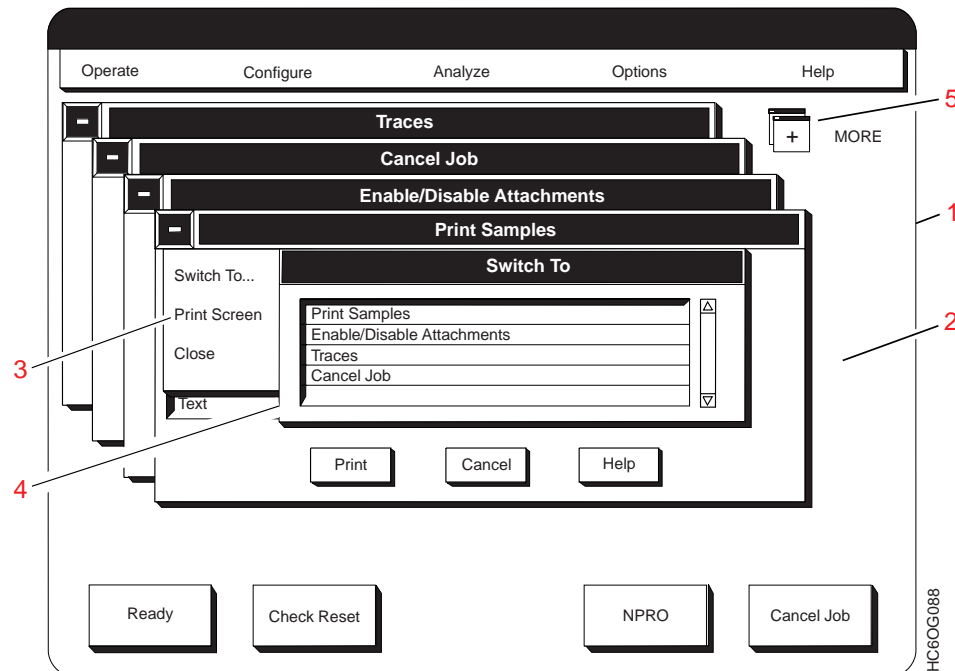

Figure 9. Procedure Windows in Cascade Format

## Screen Saver Timeout

When there is no user interaction or error condition on the operator console for a period of time, the console goes blank. Only a “floating” logo (screen saver) appears.

To return to the normal display, simply touch the screen.

The screen saver timeout period (length of time without user interaction before the screen saver comes on) is set under the **Configure Printer** procedure. The timeout period ranges from 0 to 60 minutes. You may set different timeout periods for each printer in duplex mode and for both Printer 1 and Printer 2 in simplex mode. In



dual simplex mode, if you make different settings for Printer 1 and Printer 2, the shortest of the two settings is used by both printers.

## Symbols and Visual Cues

The Display Touch Screen windows contain several symbols that act as visual cues. These symbols represent conditions or actions. They can help you understand and use the windows. Table 5 shows and explains the symbols that are used on the windows.

Table 5. Symbols and Visual Cues









Visual Cue	Explanation
+	The plus sign appears under your finger when you touch the monitor screen surface. It moves with your finger if you move your finger across the screen surface. The + sign is used to point to items to select them (by removing your finger from the screen surface).
 A26O0023	This is the system menu symbol. Every procedure window contains a system menu symbol. When you select this symbol, a pull-down menu appears allowing you to close the window, print the screen, or switch to other active windows.
 A26O0026	Information often appears on the procedure windows in boxed areas called fields. This three-dimensional outline signifies a selectable field. You can select any field with this three-dimensional outline. A pop-up window, a keyboard, or a keypad window appears when you select a field that you can change.
 A26O0027	This two-dimensional outline signifies a field that you cannot change. You cannot select any field with this two-dimensional outline. Text in the two-dimensional box is for your information only.
 A26O0018	This is the scroll bar. It appears next to some fields that you can change. Use the scroll bar to view additional information that cannot fit in a field. You can scroll up and down in the field by selecting the up and down arrows of the scroll bar.
 A26O0019	This is the scroll box. The scroll box varies in size and location within the scroll bar, which indicate how much more information is available in the corresponding field. If the scroll box fills the entire space between the scroll bar arrows, then all text is currently displayed and the scroll bar is not active. If it does not fill the scroll bar, scrolling up or down reveals more information. The scroll box moves down within the scroll bar as you scroll down within the information.
Grayed out text	Text that is grayed out signifies that the procedure or pushbutton is inactive. You cannot select a grayed-out item.

Table 5. Symbols and Visual Cues (continued)

Visual Cue	Explanation
 <p>A26O0020</p>	<p>This symbol indicates that there are active procedure windows that are not displayed on the Display Touch Screen. You must use the “Switch to” procedure in the system menu to view active procedure windows that are not displayed.</p>
 <p>A26O0028</p>	<p>This symbol appears within some field boxes that you can change. When you select a field containing this symbol, a keyboard, keypad, or hexpad window appears for you to make an entry.</p>
 <p>A26O0021</p>	<p>This symbol appears within some field boxes. It indicates that this field contains more choices than are currently displayed. When you select this field, a pop-up window appears containing a selection list box with the additional choices.</p>
 <p>A26O0022</p>	<p>Pushbutton or menu item text that is followed by an ellipsis indicates that when you select that item, another window appears that requires you to make further selections.</p>
 <p>A26O0024</p>	<p>This symbol indicates the presence of a <i>Caution</i> or <i>Warning</i> message.</p>
 <p>A26O0017</p>	<p>This symbol indicates that the printer is processing your selection. Please wait.</p>

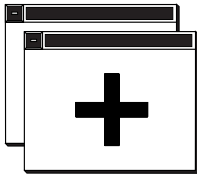
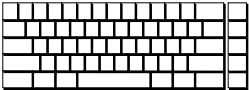
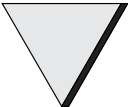
---

## Chapter 5. Task Summary

The following sections summarize the functions available from the printer pull-down menus.

| Figure 10 on page 44 shows all pull-down menu procedures. It also shows which  
| pull-down menu you use to access each procedure. Shading indicates the user  
| authorization level that is required of each procedure.

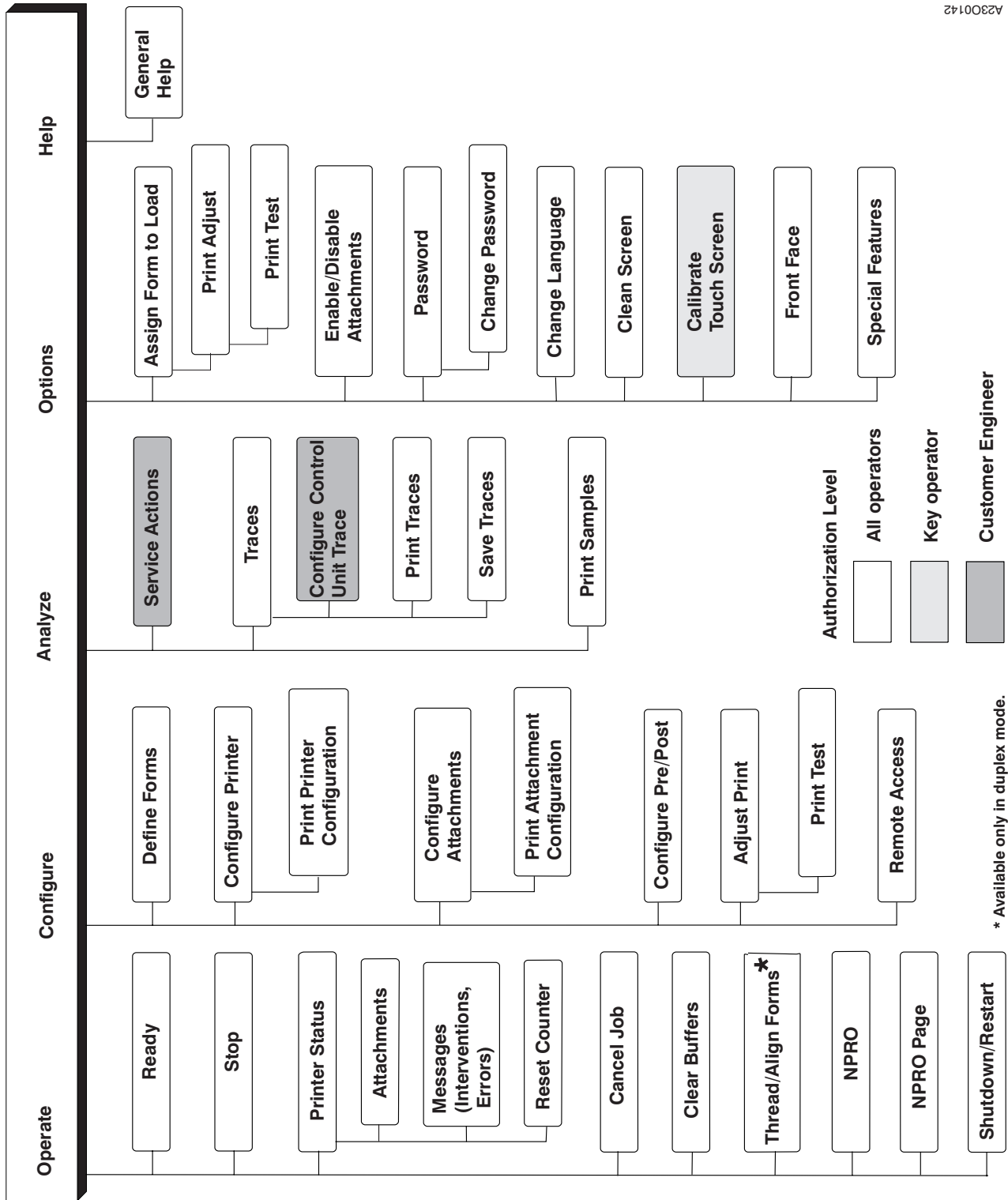

A2300142

Figure 10. Procedure Access Chart

---

## Operate Pull-Down Menu

Figure 11 shows the selections available on the Operate pull-down menu.

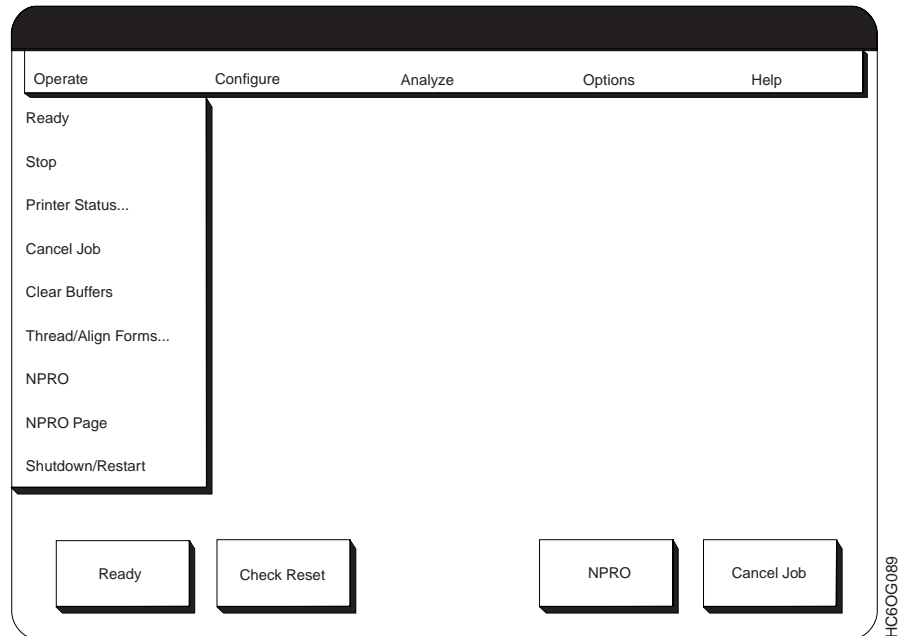

Figure 11. Operate Pull-Down Menu

### Ready

Makes the complete system (both printers) Ready when it is in duplex mode. It also makes the individual printer Ready when it is in simplex or dual simplex mode. If pages are waiting to be printed and the system or printer is online to the host, printing begins.

**Stop** Finishes the page that is currently printing. It then makes the complete system (both printers) Not Ready in duplex mode or the individual printer Not Ready in simplex or dual simplex mode.

### Printer Status...

Displays status information about the system or printer. See “Status Messages” on page 278 for more information.

### Cancel Job

Lets you cancel the job that is currently printing. In simplex or dual simplex mode, only the individual printer must be in a Not Ready state. See “Canceling a Job” on page 78 for more information.

### Clear Buffers

Clears the print buffers. (You must make the printer Not Ready before you select Clear Buffers.) This procedure allows the host to use PSF Forward and Backward commands.

### Thread/Align Forms...

Establishes the front-to-back synchronization in a two-printer system. This procedure is available only in duplex mode. See “Thread/Align Forms” on page 152 for more information.

**NPRO**

Non-process runout (NPRO) moves forms forward through the forms path. See "Advancing Forms Using the NPRO and NPRO Page Functions" on page 75 for more information.

**NPRO Page**

Moves the forms forward to the next top-of-form position. See "Advancing Forms Using the NPRO and NPRO Page Functions" on page 75 for more information.

**Shutdown/Restart**

Lets you shutdown or restart the printers.

- **Shutdown** closes all of the active procedures, disables host attachments, and safely prepares the system so that you can power off the control unit. In duplex mode, Shutdown affects the complete system. In simplex or dual simplex mode, Shutdown applies to just the printer for which the procedure was selected. You can still use the other printer.
- **Restart** unloads and then reloads the control unit internal code. This resets pointers, counters, and other controls. In duplex mode, the complete system (both printers) undergoes a Restart. In simplex or dual simplex mode, the Restart applies only to the printer you are restarting. You can still use the other printer.

See "Shutting Down and Restarting the System" on page 61 for more information.

---

## Configure Pull-Down Menu

Figure 12 shows the selections available on the Configure pull-down menu.

**Note:** If the printer is not stopped, some items are “grayed out.”



Figure 12. Configure Pull-Down Menu

### Define Forms...

Lets you change, add, and delete form definitions. You must define a form before you can assign and load it on a printer. See “Defining Forms” on page 247 for more information.

### Configure Printer...

Lets you display, update, or print out a copy of the printer configuration. See “Configuring the Printer” on page 219 for more information.

### Configure Attachments...

Lets you display, update, or print the configuration settings of all installed attachments. See “Configuring the Host Attachments” on page 229 for more information.

### Configure Pre/Post...

Lets you add, delete, or change the specifications of preprocessing or postprocessing device interfaces. See “Configuring Preprocessing/Postprocessing Devices/Interfaces” on page 241 for more information.

### Adjust Print...

Shifts the logical page on a form when you are using preprinted forms or other forms that require precise alignment. See “Adjusting the Print Position” on page 68 for more information.

### Remote Access...

Lets you enable and configure remote access to the printer via Simple

Network Management Protocol (SNMP), Remote Management Interface (RMI), and Modem. See “Configuring Remote Access” on page 245 for more information.



## Analyze Pull-Down Menu

Figure 13 shows the selections available on the Analyze pull-down menu.

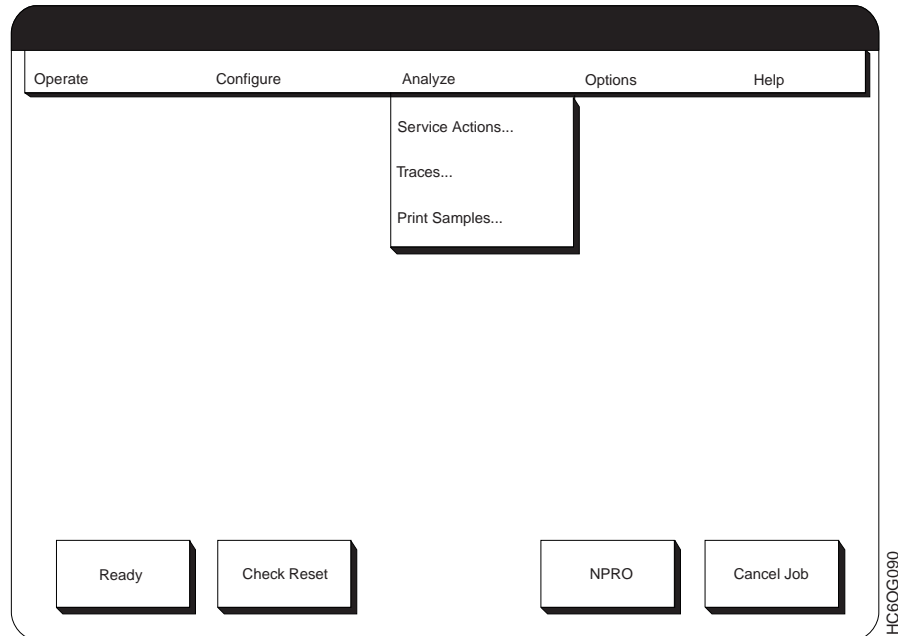

Figure 13. Analyze Pull-Down Menu

### Service Actions...

Used only by a service representative and protected by a **Customer Engineer** user authorization level password.

### Traces...

Lets you select a trace to run, start the trace, stop the trace, save a trace to diskette, and print selected traces. See "Running Traces" on page 148 for more information.

### Print Samples...

Lets you print a variety of sample pages. See "Checking Print Quality" on page 85 for more information.

## Options Pull-Down Menu

Figure 14 shows the selections available on the Options pull-down menu.

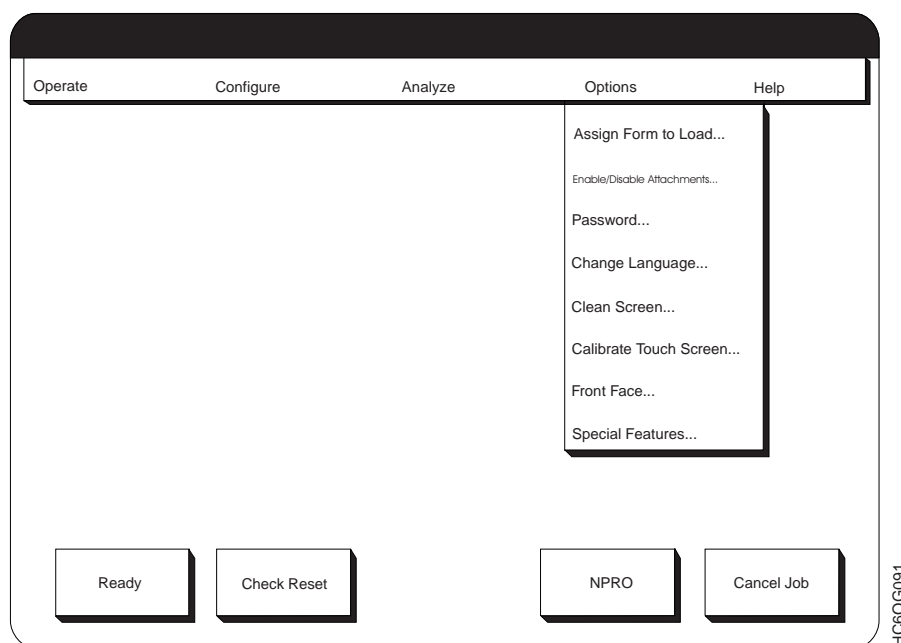

Figure 14. Options Pull-Down Menu

### Assign Form to Load...

Assigns the defined name of the form you are loading. (A form does not appear on the list until you define it.) From within this procedure, you can also invoke the **Adjust Print** and **Print Test** procedures. See “Loading Forms (Simplex or Dual Simplex Mode)” on page 102 or “Loading Forms (Duplex Mode)” on page 115 for more information.

### Enable/Disable Attachments...

Lets you enable and disable the host system attachments that are installed on the system. See “Enabling and Disabling Attachments” on page 63 for more information.

### Password...

Lets you set the authorization level of the person who is working on the printer. It also allows you to change the user authorization password. Access to higher user authorization levels is password protected. See “Changing the Password or Authorization Level” on page 79 for more information.

### Change Language...

Lets you change the language that is used for all text within Display Touch Screen windows. See “Changing the Language of Messages” on page 218 for more information.

### Clean Screen

Gives you 30 seconds to clean the face of the monitor. If one 30 second interval is not long enough, you can repeat this procedure as many times as necessary.

**Calibrate Touch Screen**

Removes the displacement between where you touch the screen surface and the small (+) symbol that appears on the screen when you touch it.

**Front Face**

Lets you place a blank page between jobs that have an odd number of pages. It also ensures that jobs that require a certain folding pattern are printed correctly. See "Checking for a Front-Facing Page" on page 81 for more information.

**Special Features**

Lets you enable, disable, install, and uninstall special features (customer-requested features that are also known as RPQs). You can install special features from a diskette or from the printer hard disk drive. You must both install and enable the feature before it becomes functional.

## Help Pull-Down Menu

The **Help** pull-down menu has only one choice, **General Help**. **SELECTING General Help** displays general information about the Display Touch Screen.

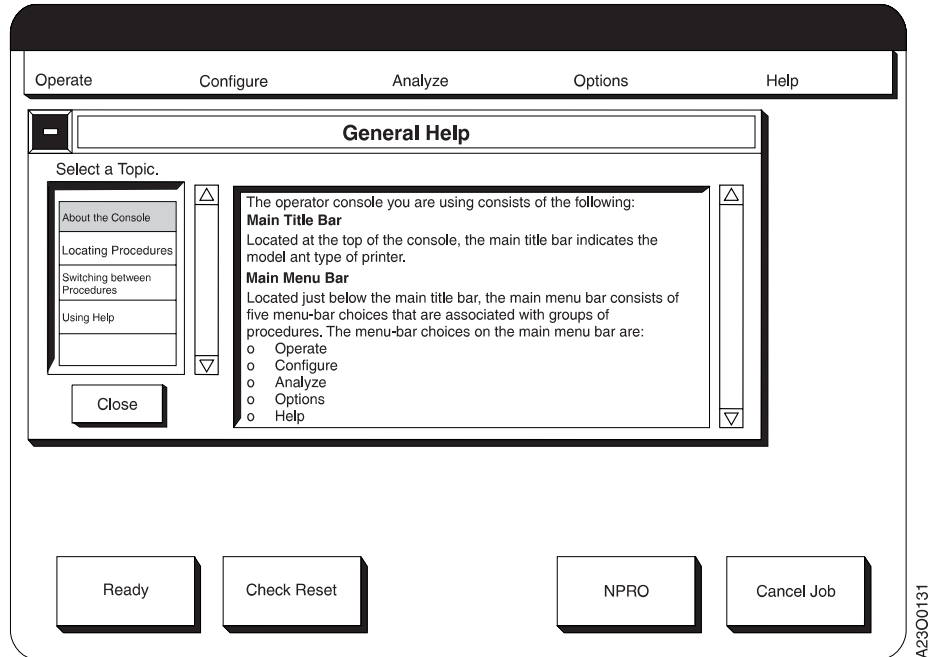

Figure 15. General Help Window

## Additional Help

All procedure windows contain a **Help** pushbutton, which displays information about performing the procedure. This information usually includes a summary of the procedure, directions for performing the procedure, and an explanation of each pushbutton in the procedure window. For example, selecting the **Help** pushbutton when you are defining forms causes the following window to appear.

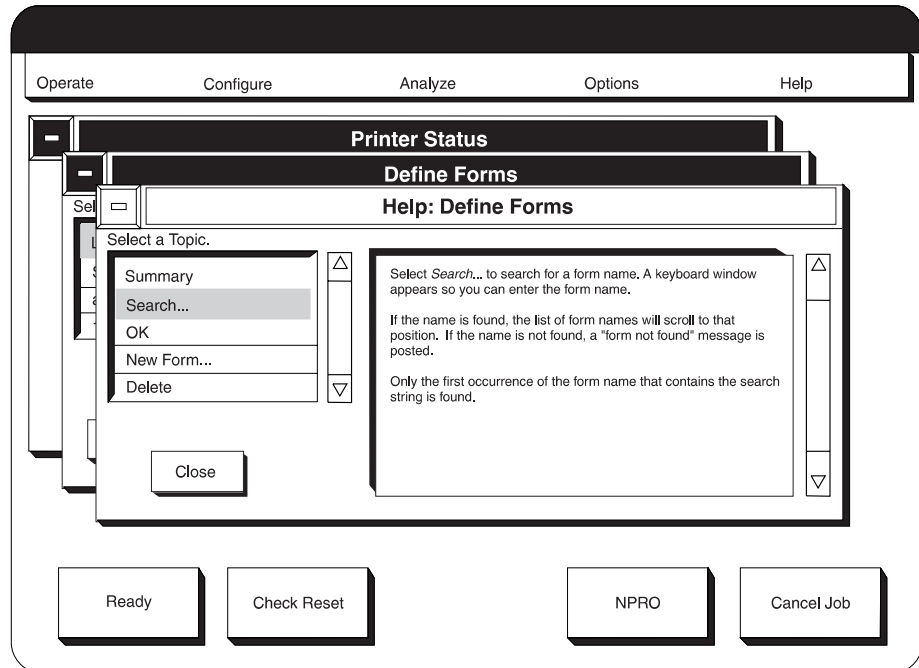

Figure 16. Define Forms Help Window



---

## Chapter 6. Operator Responsibilities

Controlling the System Power . . . . .	56	Error and Jam Recovery . . . . .	119
Local/Remote Power Control. . . . .	57	Adding Supplies . . . . .	119
Powering On the System . . . . .	57	Nonprocess Runout (NPRO) . . . . .	120
In Host-Controlled Remote Mode . . . . .	58	Recovering from a Forms Jam (Simplex	
In Local-Controlled Mode . . . . .	59	Operations). . . . .	121
Powering Off the System . . . . .	60	Jams Within the Printer Engine . . . . .	122
In Host-Controlled Remote Mode . . . . .	60	Jam Recovery Procedures . . . . .	123
In Local-Controlled Mode . . . . .	60	Jams Between the Printer and a Postprocessing	
Emergency Power Off . . . . .	60	Device . . . . .	126
Shutting Down and Restarting the System . . . . .	61	Recovering from a Forms Jam (Duplex	
Shutting Down the System . . . . .	61	Operations). . . . .	127
Restarting the System . . . . .	62	Jams Within Printer 1 . . . . .	129
Enabling and Disabling Attachments . . . . .	63	Jams Within Printer 2 . . . . .	131
Remote Channel Enable/Disable. . . . .	63	Jam Between Printer 1 and Printer 2 . . . . .	134
Local Channel Enable/Disable . . . . .	63	Jams Between the Printer and a Postprocessing	
Enabling a Host Attachment . . . . .	64	Device . . . . .	134
Disabling a Host Attachment . . . . .	64	Recovering from a Forms Jam in the	
Adjusting the Display Touch Screen Monitor . . . . .	65	Postprocessing Device . . . . .	135
User Controls . . . . .	65	Clearing the Forms Path . . . . .	136
On-Screen-Display Controls . . . . .	66	Transfer Station Area . . . . .	136
Adjusting the Print Position . . . . .	68	Fuser and Stacker Areas . . . . .	140
Adjusting the Volume of the Operator Alert		Stacker and Pendulum Area . . . . .	143
Assembly . . . . .	74	Suggestions for Preventing Jams . . . . .	144
Advancing Forms Using the NPRO and NPRO		Reporting Printer Usage . . . . .	146
Page Functions . . . . .	75	Running Traces . . . . .	148
NPRO Procedure . . . . .	75	Adjusting the Preheat Temperature . . . . .	150
Simplex Mode . . . . .	76	Poor Fusing - Simplex Mode . . . . .	151
Duplex Mode . . . . .	76	Forms Stick Together . . . . .	151
NPRO Page Procedure . . . . .	76	Heat Damage — Printer Running . . . . .	151
Simplex Mode . . . . .	77	Thread/Align Forms. . . . .	152
Duplex Mode . . . . .	77	Forms Are Loaded Through Both Printers . . . . .	154
Canceling a Job . . . . .	78	Threading Without Printing . . . . .	155
Changing the Password or Authorization Level . . . . .	79	Print While Threading . . . . .	156
Checking for a Front-Facing Page . . . . .	81	Forms Are Not Loaded In Printer 2. . . . .	158
Checking the Forms Alignment . . . . .	84	Threading Without Printing . . . . .	158
Checking Print Quality . . . . .	85	Print While Threading . . . . .	160
Cleaning the Oiler Belt . . . . .	86	Forms Are Broken Between the Printers . . . . .	162
Cleaning the Printer . . . . .	88	Threading Without Printing . . . . .	163
Connecting an Accessory to the Operator Alert		Printing While Threading . . . . .	165
Contacts . . . . .	101	Threading the Buffer/Flipper Unit . . . . .	167
Loading Forms (Simplex or Dual Simplex Mode) . . . . .	102	Straight Line Configuration . . . . .	167
Loading Forms (Duplex Mode) . . . . .	115	Left Angle Configuration . . . . .	168
Adjusting the Stacker Table Height . . . . .	117	Unloading the Stacker . . . . .	169
Preprocessing and Postprocessing Instructions . . . . .	118	Switching Printer Modes (Dual Simplex/Duplex) . . . . .	172
Powering On and Off Pre/Post Devices . . . . .	118	Switching from Duplex to Dual Simplex Mode . . . . .	172
Enabling/Disabling Pre/Post Interfaces . . . . .	118	Switching from Dual Simplex to Duplex Mode . . . . .	172
Using the Printer Stacker . . . . .	119	Switching Print Resolution. . . . .	174

This chapter contains step-by-step instructions for performing most printer operator tasks. The tasks of enabling and disabling attachments, shutting down and restarting the system, and controlling system power are grouped together in the front of the chapter. The remaining tasks are not presented in order of importance or frequency of use.

**Notes to the Operator:**

1. In some cases, the tasks described in this chapter correspond directly to the action messages you see on the Display Touch Screen windows.
2. The instructions in this section describe exactly how to do each step. They also include tips to help you prevent common problems. Before you begin an unfamiliar task, read all the information. Then carefully follow the step-by-step instructions.
3. For information about other operator tasks, see “Chapter 8. Configuring the System” on page 217 and “Chapter 7. Ordering and Replacing Supplies” on page 175.

---

## Controlling the System Power

The following figure shows a Power Control Panel.

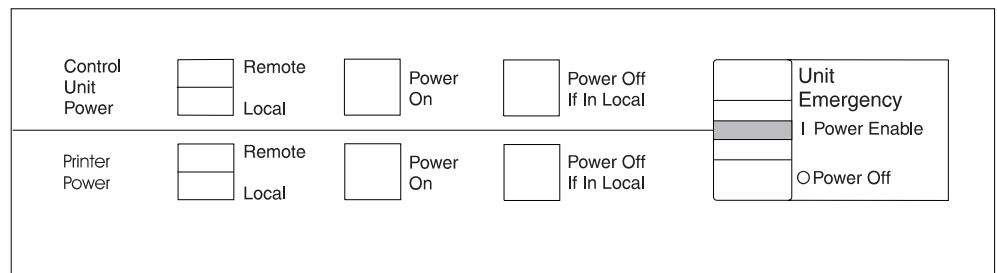

Printer 1 in a duplex or dual simplex printing system has two sets of power controls. One is for the Printer Utility Module (PUM) frame, which is labeled Control Unit on the Power Control Panel. The other is for the printer that is attached to the PUM frame.

Printer 2 in a duplex system and a simplex-only printer also has two sets of power controls. One is for the Advanced Function Common Control Unit (AFCCU) frame, which is labeled Control Unit on the Power Control Panel. The other is for the printer that is attached to the AFCCU frame. Each element in the system (Printer 1 frame, Printer 2 frame, the AFCCU frame, and the PUM frame) has the following:

- A **Local/Remote** switch
- A **Power On** switch
- A **Power Off if in Local** switch.

These switches allow many combinations of Local/Remote power control and power on/off control. Each Power Control Panel in the system also contains a **Unit Emergency** switch.



**Attention!**

The **Unit Emergency** switch lets you turn off *all* power to the system in the case of an emergency.

**Do not use the Unit Emergency Power Off switch to power off the system unless you have an emergency. Doing so can cause loss of data and hardware problems in the AFCCU.**

## Local/Remote Power Control

You can press the **Remote** and **Local** switches on the Power Control Panel to change power control from local to remote at any time. Local power control means that you can turn power on and off using the switches on the Power Control Panel. Remote power control means that you turn power on and off from another source, as shown in Table 6.

Table 6. Remote Power Control

Element:	Remote Power Controlled From:
Control Unit Power (AFCCU Frame)	Host System Console
Printer Power (Printer 1 and Simplex)	AFCCU Frame
Control Unit Power (PUM Frame)	AFCCU Frame
Printer Power (Printer 2)	AFCCU Frame

## Powering On the System

You can switch power on for the complete system for duplex or simplex mode use. You can also switch power on for only one printer and its associated control unit in simplex mode when one of the two system printers is not operable and needs repair. In either mode and with the use of either printer, you must switch the AFCCU power on.

How you switch power on for the system depends on whether power control is set to **Local** or **Remote**.

**Notes:**

1. To switch power on for Printer 1 with Printer 2 powered-off, the AFCCU frame must still have power on.
2. The **Unit Emergency** switch in each printer must be in the **Power Enable** position before you can switch power on to that printer.
3. If a D208 error occurs after you switch power on for the system, do the following:
  - a. Switch power off for the system.
  - b. Wait two minutes.
  - c. Switch power on for the system again.

If you are operating the system in dual simplex mode and leave one printer powered-off, the D208 error remains on the powered-off printer window.

## In Host-Controlled Remote Mode

**For duplex systems:** When the system master power control is from the host system console, set the Local/Remote switches as shown in Table 7 for the various combinations of elements you want to be powered-on.

Table 7. Remote System Power Control - Duplex Models

Elements To Be Powered-On	Local/Remote Switch Setting			
	AFCCU Frame	Printer 2 Frame	PUM Frame	Printer 1 Frame
AFCCU, Printer 1, PUM, Printer 2	Remote	Remote	Remote	Remote
AFCCU, Printer 2	Remote	Remote	Local	Local
AFCCU, PUM, Printer 1	Remote	Local	Remote	Remote

**For simplex systems:** When the system master power is from the host system console, set the Local/Remote switches to Remote.

When the Local/Remote switch is set to Remote, do the following:

1. Ensure that both printers in a duplex system are connected to a three-phase electrical outlet that is reserved for the printers.
2. Ensure that the printer in a simplex system is connected to a three-phase electrical outlet that is reserved for the printer.
3. Inform the host system console operator that the system is ready to be powered-on.
4. Respond to any error or intervention messages that appear on the Display Touch Screen during the power-on sequence.

At the completion of the power-on sequence, the Display Touch Screen displays a **Printer Status** window. In duplex mode, the **Printer Status** window is overlaid with a **Thread/Align Forms** procedure window.

5. Load forms. See “Loading Forms (Simplex or Dual Simplex Mode)” on page 102 or “Loading Forms (Duplex Mode)” on page 115 for details.
6. If you are printing in duplex mode, do the **Thread/Align Forms** procedure. See “Thread/Align Forms” on page 152 for details.
7. Enable host attachments, as required. See “Enabling and Disabling Attachments” on page 63 for details.
8. Make the system ready.
  - If you are printing in duplex mode, **SELECT** the **Ready** pushbutton on the main Display Touch Screen window.
  - If you are printing in simplex or dual simplex mode, **SELECT** the **Ready** pushbutton on the main Display Touch Screen window for one or both printers.

## In Local-Controlled Mode

**For duplex systems:** When the system master power control is to be controlled locally, set the Local/Remote switches as shown in Table 8 for the various combination of elements for which you want power on.

Table 8. Local System Power Control - Duplex Models

Elements To Be Powered-On	Local/Remote Switch Setting			
	AFCCU Frame	Printer 2 Frame	PUM Frame	Printer 1 Frame
AFCCU, Printer 1, PUM, Printer 2	Local	Remote	Remote	Remote
AFCCU, Printer 2	Local	Remote	Local	Local
AFCCU, PUM, Printer 1	Local	Local	Remote	Remote

**For simplex systems:** When the system master power is to be controlled locally, set the Local/Remote switches to Local.

When the Local/Remote switch is set to Local, do the following:

1. Ensure that both printers in a duplex system are connected to a three-phase electrical outlet that is reserved for the printers.
2. Ensure that the printer in a simplex system is connected to a three-phase electrical outlet that is reserved for the printer.
3. Press the AFCCU frame **Control Unit Power On** switch for any of the preceding combinations of elements listed.
4. Respond to any error or intervention messages that appear on the Display Touch Screen during the power-on sequence.
5. At the completion of the power-on sequence, the Display Touch Screen displays a **Printer Status** window. In duplex mode, the **Printer Status** window is overlaid with a **Thread/Align Forms** procedure window.
6. Load forms. See “Loading Forms (Simplex or Dual Simplex Mode)” on page 102 or “Loading Forms (Duplex Mode)” on page 115 for details.
7. If you are printing in duplex mode, do the **Thread/Align Forms** procedure. See “Thread/Align Forms” on page 152 for details.
8. Enable host attachments, as required. See “Enabling and Disabling Attachments” on page 63 for details.
9. Make the system ready.
  - If you are printing in duplex mode, **SELECT** the **Ready** pushbutton on the main Display Touch Screen window.
  - If you are printing in simplex or dual simplex mode, **SELECT** the **Ready** pushbutton on the main Display Touch Screen window for one or both printers.

## Powering Off the System

For duplex systems operating in duplex mode and for simplex systems, you must switch power off to the complete system whenever you want to switch power off to any single element. However, for duplex systems operating in dual simplex mode, you do not have to switch power off to the complete system to power off any single element.

### In Host-Controlled Remote Mode

1. On the Display Touch Screen, from the **Operate** pull-down menu **SELECT** the **Shutdown/Restart** procedure.
2. On the **Shutdown/Restart** window, **SELECT** the **Shutdown** pushbutton.  
(In dual simplex mode, on the **Shutdown/Restart** window **SELECT** the **Shutdown** pushbutton, for the other printer if desired.)  
Wait for a Shutdown Complete message to appear on the Display Touch Screen.  
(In dual simplex mode, this message appears only if both printers are shutdown.)
3. Inform the host system console operator that you want to switch power off to the system.
4. The host console operator will inform you when both printers have been switched offline at the host.
5. The host system console operator switches power off to the system remotely.

### In Local-Controlled Mode

1. On the Display Touch Screen from the **Operate** pull-down menu, **SELECT** the **Shutdown/Restart** procedure.
2. On the **Shutdown/Restart** window, **SELECT** the **Shutdown** pushbutton.  
(In dual simplex mode on the **Shutdown/Restart** window, **SELECT** the **Shutdown** pushbutton for the other printer if desired.)  
Wait for a Shutdown Complete message to appear on the Display Touch Screen.  
(In dual simplex mode, this message appears only if both printers are shutdown.)
3. Press the AFCCU **Power Off if in Local** switch for any combination of powered-on elements.

### Emergency Power Off

In case of an emergency, you can set the **Unit Emergency** to **Power Off** to remove all power from the frame (PUM or AFCCU) in which the switch is installed and from the attached printer engine. This action on one of the system printers does not effect power on the other printer in the system, but causes the other printer to be functionally inoperable.

#### **Attention!**

**Do not use Unit Emergency Power Off switch to switch power off to the system unless you have an emergency. Doing so can cause loss of data and hardware problems in the AFCCU.**

## Shutting Down and Restarting the System

Use this procedure when:

- A recovery action procedure instructs you to either **Shutdown** or **Restart** the system
- You are changing the Configure Printer **Printer Mode** setting from dual simplex to duplex
- You want to do a general shutdown and power off the system.

You must use the **Shutdown** procedure to do the following:

- Close all active procedures
- Disable all enabled host system attachments
- Safely prepare the system so that the AFCCU may be powered-off.

**Note:** You should always do this procedure before you switch off power to the AFCCU, regardless of whether a recovery action procedure instructed you to switch power off to the system or you are doing it on your own.

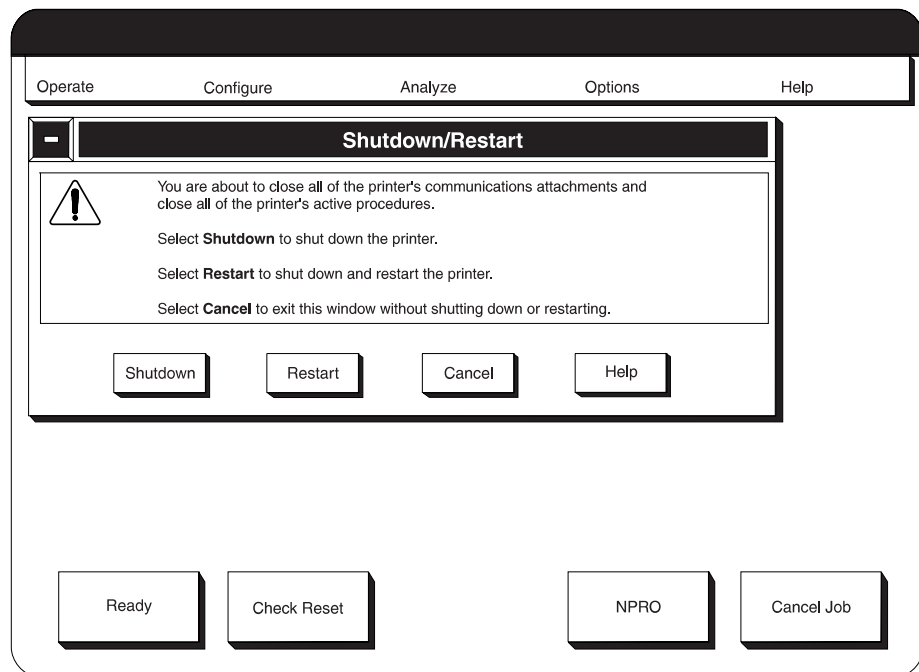

### Shutting Down the System

**Note:** With a duplex configuration in duplex mode or with a simplex printer, this procedure shuts down the complete system (both printers in a duplex configuration). In dual simplex mode, this procedure shuts down only the target printer. The other printer remains active and usable. If you are shutting down the last active dual simplex printer, the complete system is shutdown.

Note that once you have shutdown a dual simplex printer using this procedure, the only way to get it back to active use is to shutdown the other dual simplex printer also.

1. From the **Operate** pull-down menu, **SELECT** the **Shutdown/Restart** procedure.
2. On the **Shutdown/Restart** procedure window, **SELECT** the **Shutdown** pushbutton.

If you decide that you do not want to shutdown or restart the system, **SELECT** the **Cancel** pushbutton.

If the printers are in duplex mode, or if the printers are in dual simplex mode and the final simplex printer is being shutdown, the following messages appear:

- The message Shutdown in Progress appears after you select the **Shutdown** pushbutton.
  - Shutdown Complete appears when the shutdown process is complete.
3. If necessary, switch power off to the system or the individual printer. See “Controlling the System Power” on page 56 for details.

As required, correct the problem that caused you to initiate the procedure.

## Restarting the System

**Note:** In duplex mode, this procedure applies to the complete system (both printers). In dual simplex mode, this procedure applies to the target printer only.

1. From the **Operate** pull-down menu, **SELECT Shutdown/Restart**.
2. On the **Shutdown/Restart** procedure window, **SELECT** the **Restart** pushbutton.
3. Enable the host attachments, if necessary. See “Enabling and Disabling Attachments” on page 63 for details.
4. Try the operation that was in progress when the **Restart** was requested again.

---

## Enabling and Disabling Attachments

Do this task whenever you need to *enable* (functionally connect) or *disable* (disconnect) the printer from the controlling computer system channel. Note that enabling and disabling an attachment is not the same as physically attaching or detaching the attachment.

To accept commands and data from the system, a controlling computer system channel must be enabled, and the printer must be Ready.

You need to enable attachments whenever you do the following:

- Switch power on to the system in duplex
- Switch power on to the system in dual simplex
- Switch power on to the system in simplex mode without using Auto Start
- Whenever you need to enable a disabled attachment.

The enable/disable status of installed host attachments may be set differently between duplex and dual simplex modes and between Printer 1 and Printer 2 in dual simplex.

### Remote Channel Enable/Disable

If your installation uses two System/370 Parallel Channels, a “Remote Channel Enable/Disable” feature may be installed (contact your service representative if you are not sure). If the “Remote Channel Enable/Disable” feature is installed, you must notify the remote operator whenever you require the Parallel channels to be enabled or disabled.

**Note:** Although there is nothing to prohibit the use of the **Enable/Disable Attachments** procedure, you should **not** use it when the “Remote Channel Enable/Disable” feature is installed.

### Local Channel Enable/Disable

**Note:** Do not use this procedure if the “Remote Channel Enable/Disable” feature is installed.

The enable/disable status of host attachments cannot be changed for an individual printer or for the complete two-printer system unless the printers are in the Not Ready state.

You may make the printers Not Ready at either the printer Display Touch Screen window or the stacker control panel. You must use that same panel or window to make the printers Ready.

- In duplex mode, **SELECT** the **Stop** pushbutton on the Display Touch Screen main window.
- In dual simplex mode, **SELECT** the **Stop** pushbutton on the Display Touch Screen window for the target printer.
- In simplex mode, **SELECT** the **Stop** pushbutton on the Display Touch Screen window for the printer.

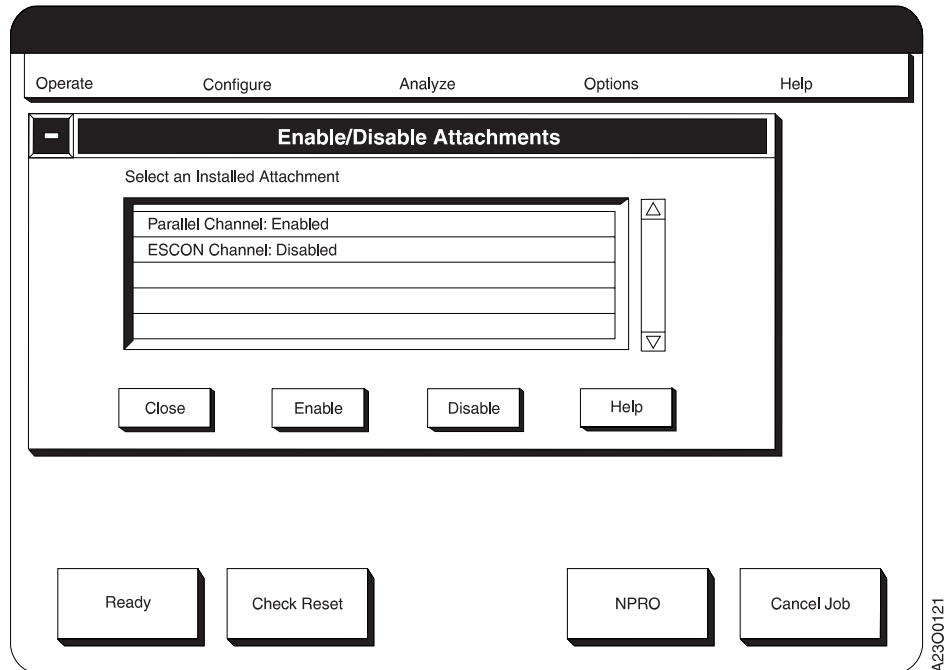

### Enabling a Host Attachment

1. From the **Options** pull-down menu, **SELECT** the **Enable/Disable Attachments** procedure.
2. From the list of currently installed attachments, **SELECT** the attachment you want to enable, then **SELECT** the **Enable** pushbutton.
3. Make the printers Ready.
  - In duplex mode, **SELECT** the **Ready** pushbutton on the Display Touch Screen main window.
  - In dual simplex mode, **SELECT** the **Ready** pushbutton on the target printer Display Touch Screen window.
  - In simplex mode, **SELECT** the **Ready** pushbutton on the Display Touch Screen window.

### Disabling a Host Attachment

1. From the **Options** pull-down menu, **SELECT** the **Enable/Disable Attachments** procedure.
2. From the list of currently installed attachments, **SELECT** the attachment you want to disable, then **SELECT** the **Disable** pushbutton.
3. If you want the printer active for attachments that are not disabled, choose one of the following methods:
  - In duplex mode, **SELECT** the **Ready** pushbutton on the Display Touch Screen main window.
  - In dual simplex mode, **SELECT** the **Ready** pushbutton on the target printer Display Touch Screen window.
  - In simplex mode, **SELECT** the **Ready** pushbutton on the Display Touch Screen window.



## Adjusting the Display Touch Screen Monitor

You may decide that some physical aspect of the information image that is displayed on the face of the monitor needs adjusting. You can adjust the image with the user controls at the bottom of the monitor and the On-Screen-Display (OSD) icons.

### User Controls

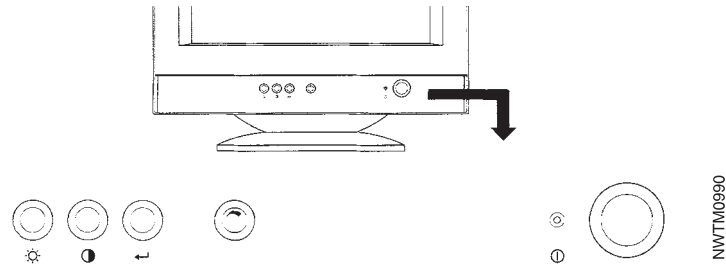







Figure 17. Operator Console User Controls

The controls at the bottom of the monitor are for the following tasks:

- Switching the monitor on and off
- Adjusting contrast and brightness
- Activating and adjusting the On-Screen-Display (OSD) control icons.

Table 9 describes the controls and how to use them.

Table 9. User Controls on the Monitor

Using This Control:	Does This:
<p><b>Power Switch</b></p> 	Switches the monitor on and off.
<p><b>OSD/Select</b></p> 	Activates the On-Screen-Display and selects a control icon.
<p><b>Highlight/Adjust</b></p> 	Pops out when pushed. Rotates to highlight OSD icons and adjusts setting after an icon has been selected.
<p><b>Contrast</b></p> 	Adjusts contrast between foreground and background.
<p><b>Brightness</b></p> 	Adjusts background brightness.

## On-Screen-Display Controls

In addition to brightness and contrast, the On-Screen-Display (OSD) controls allow you to make further adjustments to the image on the monitor. When you push in the **OSD/Select** button, the OSD main menu appears on the screen.

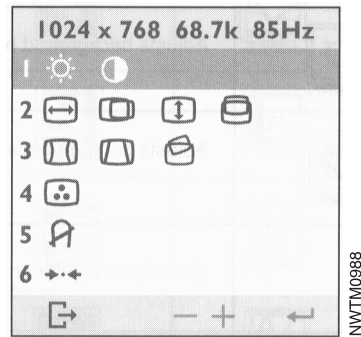

Figure 18. On-Screen-Display Main Menu

**Note:** If you do not make a selection within 6 seconds, the OSD menu disappears.

In Figure 18, the first row (brightness and contrast) is selected (highlighted). To select another row, use the **Highlight/Adjust** control to scroll to the one you want and then press the **OSD/Select** button. A submenu appears for the row you selected.

The image control rows are for the following:

Row / Submenu	Function
1	Adjusts brightness and contrast, similar to the buttons on the bottom of the monitor.
2	Adjusts horizontal size and position and vertical size and position of the image.
3	Rotates and adjusts the shape of the image.
4	Adjusts the color or the color intensity of the image.
5	Degausses the monitor when selected. Do not use this feature more than once in any 30-minute period.
6	Recalls saved settings. Highlight the required group of functions and press the <b>OSD/Select</b> button.

Use the **Highlight/Adjust** button to scroll to the adjustment icon you want to use and then press the **OSD/Select** button. Use the **Highlight/Adjust** button to adjust the setting. When the setting is correct, press the **OSD/Select** button to accept the new setting.

Several icons appear on the submenus that allow you to save adjusted settings, exit the menu, or cancel the changes and return to the main menu.

Table 10 describes the icons you use after you have adjusted a setting.

Table 10. Submenu Icons



Using This Control:	Does This:
<p>Save</p> 	Saves the adjustments you selected and returns to the main menu.

Table 10. Submenu Icons (continued)

Using This Control:	Does This:
<p data-bbox="565 268 643 296"><b>Cancel</b></p> 	<p data-bbox="740 268 1382 296">Cancels any adjustments you made and returns to the main menu.</p>
<p data-bbox="553 426 654 453"><b>Exit OSD</b></p> 	<p data-bbox="740 426 1373 453">Exits the OSD main menu after you press the <b>OSD/Select</b> button.</p>

## Adjusting the Print Position

Do this task when you load preprinted forms, adhesive labels, or other forms that require a precise registration that is not satisfied by the factory-set default registration.

### Requirement For This Procedure

You must have a print job queued so that print data is available to print test pages during this procedure. You cannot complete this procedure without queued print data available.

In printing, the term *registration* refers to the relative print positions of images that are printed at different times. For example, when you process preprinted forms, the registration is good if the new image printed by the system printer aligns correctly with the preprinted image (as shown in Figure 19).

Kuhly Conditioning			
Name	Quantity	Item #	Date
Smithson, R.T.	14	714562	05/29/90
Barckley, Wm.	03	518329	06/02/90
Martins, S.J.	08	487641	06/03/90
Balons, G.E.	21	894265	06/03/90
A-1 Towing	11	462894	06/03/90
Jones, S.W.	02	783466	06/04/90
Kelly, J.M.	16	186435	06/06/90
Fischer, G.M.	45	087462	06/07/90
Adams, T.A.	14	812576	06/07/90
Mark IV Prop.	19	428967	06/08/90
Hill, W.A.	05	932465	06/11/90
Cullen, E.T.	22	943251	06/26/90
Hertler, D.E.	10	147563	06/27/90
			R4C00037

Figure 19. Good Registration

Print that extends beyond box edges and text that overlaps other text are examples of poor registration (as shown in Figure 20).

Kuhly Conditioning			
Name	Quantity	Item #	Date
Smithson, R.T.	14	714562	05/29/90
Barckley, Wm.	03	518329	06/02/90
Martins, S.J.	08	487641	06/03/90
Balons, G.E.	21	894265	06/03/90
A-1 Towing	11	462894	06/03/90
Jones, S.W.	02	783466	06/04/90
Kelly, J.M.	16	186435	06/06/90
Fischer, G.M.	45	087462	06/07/90
Adams, T.A.	14	812576	06/07/90
Mark IV Prop.	19	428967	06/08/90
Hill, W.A.	05	932465	06/11/90
Cullen, E.T.	22	943251	06/26/90
Hertler, D.E.	10	147563	06/27/90

R4CO0038

Figure 20. Poor Registration

**Note on Point of Origin:**

When you adjust the print position of a defined forms identification name, the printer automatically stores the new *point of origin* as part of the current stored definition of that form. The point of origin remains in effect (even when the printer is powered off) until you change it later with the **Adjust Print** procedure.

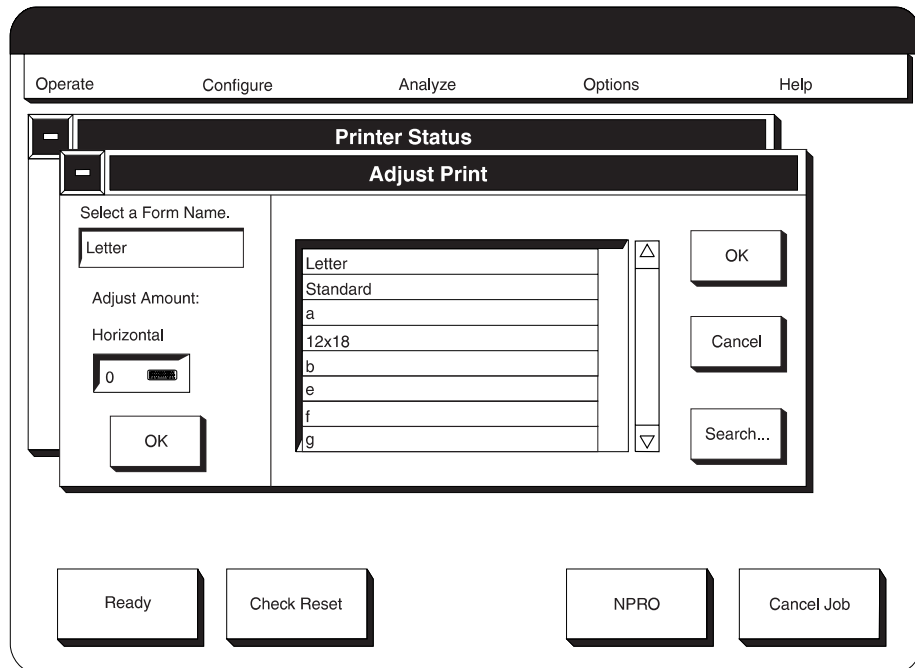

1. Ensure that the form loaded in the printer is the form selected at the **Assign Form to Load** window.

2. If the form name in the **Assign Form to Load** window is not correct, **SELECT** the **Search...** pushbutton to find the form name you want. When you have found the correct form name, **SELECT** the **OK** pushbutton twice to continue the **Adjust Print** procedure.
3. If the target printer is Ready, stop the printer by **SELECTING** the **Stop** pushbutton on the main Display Touch Screen window of the target printer.
4. Display the **Adjust Print** window by doing one of the following:
  - **SELECT** the **Configure** pull-down menu, and then **SELECT Adjust Print**.  
OR
  - **SELECT** the **Options** pull-down menu, **SELECT Assign Forms to Load**, and then **SELECT Adjust Print**.
5. In duplex mode, if the side that is displayed in the **Side to Adjust** field is not the side you want to adjust, do the following:
  - a. **SELECT** the **Side to Adjust** field.
  - b. **SELECT** the side you want to adjust. The choices are:
    - 1) Normal Duplex Side 1
    - 2) Normal Duplex Side 2
    - 3) Tumble Duplex Side 1
    - 4) Tumble Duplex Side 2

**Notes to the Operator:**

- a. For dual simplex, you have to go through this procedure twice if you want both printers to have identical forms. Do the procedure once to adjust the Form Name on Printer 1 and again to adjust the Form Name on Printer 2.
  - b. The **Front Sheet Sequence** printer configuration value informs you which side of the duplex form is being printed on each printer in the system:
    - “Front First” Value - Printer 1 prints Side 1 (front side of form), and Printer 2 prints Side 2 (back side of form)
    - “Front Second” Value - Printer 1 prints Side 2 (back side of form), and Printer 2 prints Side 1 (front side of form)

(See “Configuring the Printer” on page 219 for details.)
6. To print sample pages with the current registration values, do the following from the Display Touch Screen:

**Requirement For This Procedure**

You cannot accomplish this step and the remainder of the procedure if a queued print job is not available.

- a. On the **Adjust Print** window, **SELECT** the **Print Test** pushbutton. This displays the **Print Test** window.
  - b. If necessary, do the following to update the value in the **Number of Pages** box:
    - **SELECT** the **Number of Pages** box.
    - Use the keypad to type the correct value.
    - On the keypad window, **SELECT** the **OK** pushbutton.
  - c. On the **Print Test** window, **SELECT** the **OK** pushbutton.
7. Look at the pages just printed (located above the transfer station) to determine how much to adjust the print position.

### Things To Keep In Mind When You Adjust the Print Position:

Print jobs with data closer than 20 mm (about 1 inch) to the fold perforation or from the edges of the forms do not have the full adjustment range. For example, if the job has data that prints 10 mm (about  $\frac{1}{2}$  inch) from the fold perforation, the maximum amount that image can be shifted is 10 mm ( $\frac{1}{2}$  inch) toward the page perforation. If you attempt a larger vertical adjustment, Print Error Marker (PEMs), which the host system turns on or off, can occur.

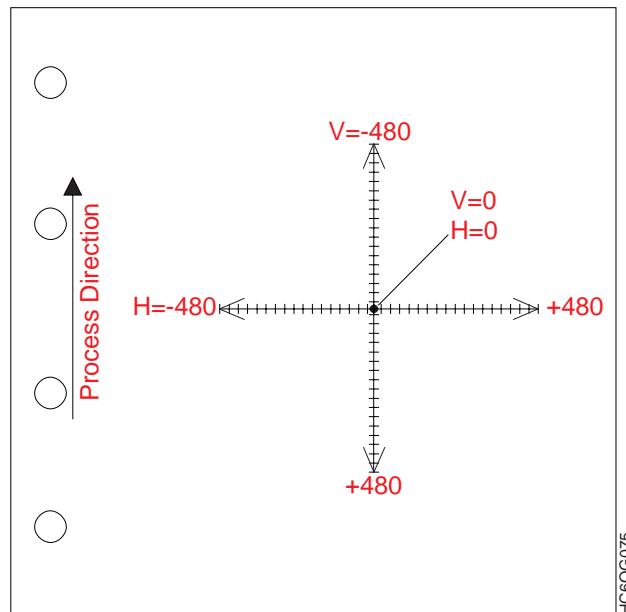

Figure 21. Factory Set Default Registration

**Note:** The horizontal (H) and vertical (V) values vary depending on the print resolution (PEL) that you selected for the printer.

#### How This Procedure Works:

Doing this procedure lets you change the point of origin on a page by adding to or subtracting from the vertical and horizontal starting positions.

Figure 21 illustrates the default point of origin (vertical=0, horizontal=0). It also shows the range of possible adjustments, which are not drawn to scale, when the print resolution is set to 480 DPI. The maximum adjustment in any direction from this position is about 6 inches.

**Note:** The InfoPrint 3000 printers show a range of either  $\pm 2880$  for 480 DPI or  $\pm 3600$  for 600 DPI.

#### What If the Adjustment Required Is Out of Range:

If more than 20 mm adjustment (from 0) is required, refer the application owner to the *Forms Design Reference for Continuous Forms Advanced Function Printers*.

The vertical and horizontal adjustment directions are always relative to the process direction (the direction that forms are moving through the printer). The vertical adjustment moves the point of origin on a line *parallel* to the forms

tractor feed holes (the process direction). The horizontal adjustment moves the point of origin on a line that is at 90° (*perpendicular*) to the forms tractor feed holes. See Figure 21 on page 71.

Be aware that the printed output can be rotated when printed.

Imagine that your sample page shows that the text is printing too high and too far to the left in relation to the preprinted form. To correct this situation, increase the vertical and horizontal positions (to move the point of origin down and to the right). Figure 22 shows the result of changing the vertical position to +7 and the horizontal position to +6. (The figure is not drawn to scale.)

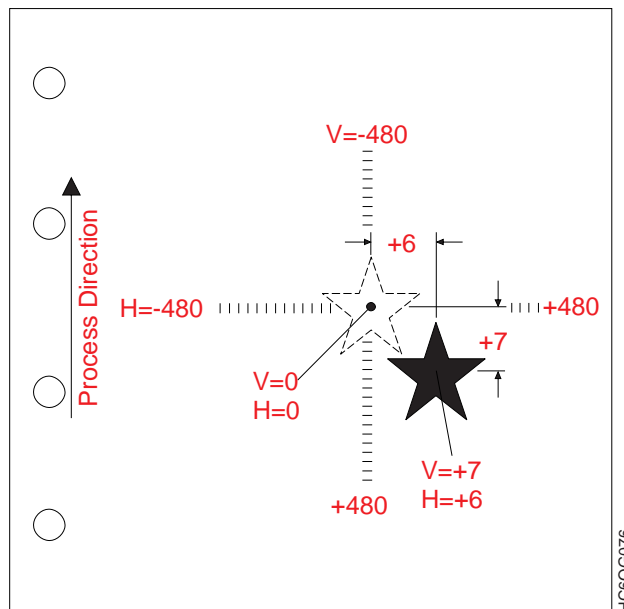

Figure 22. Sample Field Adjusted Registration

**Note:** The horizontal (H) and vertical (V) values vary depending on the print resolution (PEL) that you selected for the printer.

#### Operator Tips

- Once you have determined the adjustments for a particular form, you can make a note of the adjustment values on the “Form Identification Worksheets” on page 263.
- Be aware that occasionally some maintenance procedures can affect print position adjustment. If this happens, adjust the print position as needed.

8. To make a horizontal adjustment, do the following:
  - a. **SELECT** the **Horizontal Adjust Amount** field. This displays a keypad window.
  - b. Use the +/- pushbutton on the keypad window to set the sign of the change you will make.
  - c. Enter the new value, then **SELECT** the **OK** pushbutton to return to the **Adjust Print** window.



#### Operator Tips

- When you *increase* the horizontal value by one, you move the origin toward the *right* side of the form by one pel.
- When you *decrease* the horizontal value by one, you move the origin toward the *left* side of the form by one pel.

9. To make a vertical adjustment, do the following:
  - a. **SELECT** the **Vertical Adjust Amount** field. This displays a keypad window.
  - b. Use the +/- pushbutton on the keypad window to set the sign of the change you will make.
  - c. Enter the new value, then **SELECT** the **OK** pushbutton to return to the **Adjust Print** window.

#### Operator Tips

- When you *increase* the vertical value by one, you move the origin *down* toward the trailing page perforation by one pel.
- When you *decrease* the vertical value by one, you move the origin *up* toward the leading page perforation by one pel.

10. To print a sample to test the new values, do step 6 again.
11. If the registration is still not correct, repeat steps 7 through 10.
12. If the registration is satisfactory, **SELECT** the **OK** pushbutton on the **Adjust Print** window.
13. Make the printer Ready by **SELECTING** the **Ready** pushbutton on the Display Touch Screen window for the affected printer.

#### Operator Tips

- After the printer has run for a few seconds, **SELECT** the **Stop** pushbutton on the Display Touch Screen window for the affected printer. Then look at the output to ensure that the print position is still correct. Sometimes the print position changes slightly when forms move at full speed.
- Most applications generate a few sample pages at the beginning of each job so that you can adjust the forms without losing any output. If you need more sample pages to test, ask the host system console operator to restart the job.

---

## Adjusting the Volume of the Operator Alert Assembly

The operator alert assembly has the following main parts:

- Built-in operator alert light and buzzer
- Volume control
- External contacts that allow you to connect an alert signal of your choice. See “Connecting an Accessory to the Operator Alert Contacts” on page 101 for details.

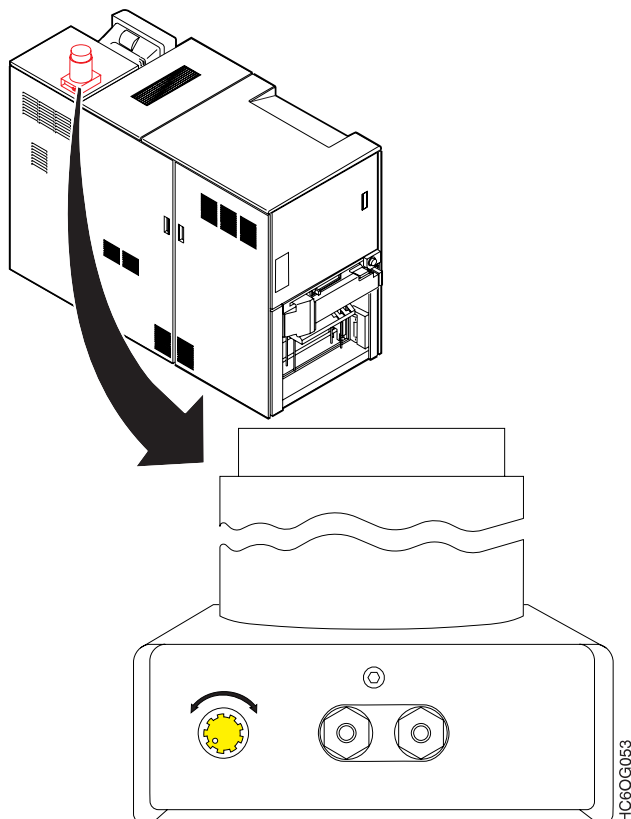

To change the volume on the printer operator alert assembly, do the following:

1. Locate the knob at the base of the operator alert assembly.
2. To *increase* the volume, turn the knob *clockwise*.
3. To *decrease* the volume, turn the knob *counterclockwise*.
4. Test the alarm volume by opening the transfer assembly.
5. Repeat steps 2 and 3 until you have adjusted the volume to the desired level.

---

## Advancing Forms Using the NPRO and NPRO Page Functions

NPRO (NonProcess RunOut) moves forms forward through the forms path.

- In simplex mode, NPRO moves the forms forward to the stacker area. Forms are fused as they move toward the stacker area.
- In duplex mode, NPRO moves forms forward through the forms path of Printer 1, the Buffer/Flipper Unit, and Printer 2. Pages that were printed on Printer 1 are printed on Printer 2, and Printer 1 processes blank pages. After all pages are printed on Printer 2, the forms move forward through the forms path of both printers without printing until all pages printed on Printer 2 are in the stacker area. Pages already printed on Printer 1 at the start of this procedure and pages printed on Printer 2 during this procedure are fused as they move toward their respective stacker areas.

The distance NPRO moves forms depends on your printer configuration. There is a fixed NPRO length that you can increase with two different configuration items. You may want to increase the fixed length, for example, if you are using a postprocessing device.

Two configuration parameters let you extend the NPRO length when END OF FORMS 078A is not indicated:

- The “Pre/postprocessor Extended NPRO” parameter in the **Configure Pre/postprocessor** procedure. See “Configuring Preprocessing/Postprocessing Devices/Interfaces” on page 241 and the “Extended NPRO” table item on page “Extended NPRO” on page 243 for more information.
- The “NPRO Length” parameter in the **Configure Printer** procedure. See “Configuring the Printer” on page 219 and the “NPRO Length” table item on page “NPRO Length” on page 223 for more information.

**Note:** If you set the “Pre/postprocessor Extended NPRO” item of an *enabled* pre/postprocessor to a non-zero value, it takes precedence over the **Configure Printer** “NPRO Length” item, regardless of the particular values specified.

### NPRO Procedure

NPRO is usable only under certain conditions, which balance safety considerations with operator convenience.

### Requirements For NPRO To Function

The following conditions must be met before NPRO can function:

- The printer is in a Not Ready state
- Forms are loaded
- The following printer conditions are **not** present:
  - Program Check
  - Out of Supplies
  - Printer Error
  - Intervention Required (except END OF FORMS 078A)
- A Thread/Align Window does not appear
- There are no errors or intervention conditions present on any preprocessing or postprocessing devices except END OF FORMS 078A.

You may do the following steps at the main Display Touch Screen window. Consistently perform all required steps at the same window.

### Simplex Mode

- Once you have ensured that the preceding conditions have been met, under the **Operate** pull-down menu **SELECT** the **Stop** pushbutton; then **SELECT** the **NPRO** pushbutton on the main Display Touch Screen window of the printer.
- Forms, starting with the page at the transfer station, move through the printer to the stacker area. The distance they move is the fixed NPRO length plus an additional length if either the “NPRO Length” or the “Pre/postprocessor Extended NPRO” values are set to a non-zero value.

### Duplex Mode

- Once you have ensured that the preceding conditions have been met, under the **Operate** pull-down menu **SELECT** the **Stop** push button; then **SELECT** the **NPRO** pushbutton on the main Display Touch Screen window of the target printer.
- Forms, starting with the page at the transfer station of Printer 1, move through both printers to the stacker area of Printer 2. The distance they move is the fixed NPRO length plus an additional length if either the “NPRO Length” or the “Pre/postprocessor Extended NPRO” values are set to a non-zero value.

## NPRO Page Procedure

NPRO Page is a single-page advance function. NPRO Page moves the forms forward to the next top-of-form position, one page at a time.

NPRO Page is active under the same conditions that allow NPRO to function. See “NPRO Procedure” on page 75.

In duplex mode, NPRO Page moves forms forward through the forms path of Printer 1 one page at a time, the Buffer/Flipper Unit, and Printer 2 toward the stacker area to the next top-of-form position. A page that is already printed on Printer 1 is printed on Printer 2, and Printer 1 processes a blank page. A page already printed in Printer 1 at the start of this procedure and a page printed in Printer 2 during this procedure are fused as they move toward their respective stacker areas.

### **Simplex Mode**

- When the printer is stopped, under the **Operate** pull-down menu **SELECT** the **NPRO Page** pushbutton on Display Touch Screen window.
- Forms advance through the printer to the next top-of-page position.

### **Duplex Mode**

- When both printers are stopped, under the **Operate** pull-down menu **SELECT** the **NPRO Page** pushbutton on Display Touch Screen window.
- Forms, starting with the page at the transfer station of Printer 1, move through both printers to the next top-of-page position.

## Canceling a Job

Do this task when you need to stop a print job and delete the print data.

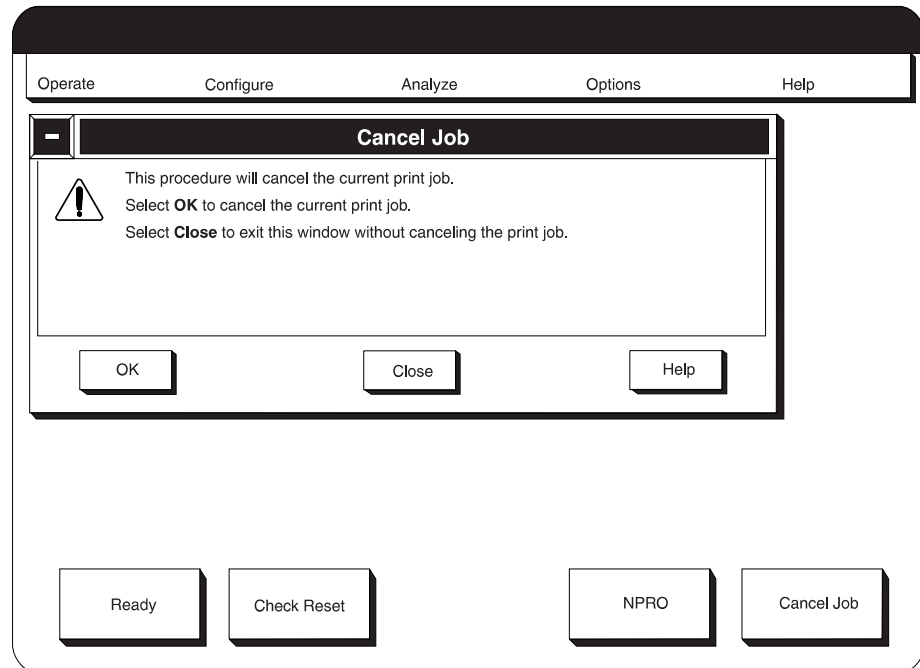

1. Stop the printers.
  - In duplex mode, you must stop both printers. To do this, **SELECT** the **Stop** pushbutton on the main Display Touch Screen window.
  - With a simplex printer or a duplex configuration in dual simplex mode, you must stop only the printer that is running the job you want to cancel. To do this, **SELECT** the **Stop** pushbutton on the main Display Touch Screen window of a simplex printer.
2. On the Display Touch Screen main window **SELECT** the **Cancel Job** pushbutton.
3. On the **Cancel Job** procedure window, **SELECT** the **OK** pushbutton.
4. Notify the host system console operator whenever you cancel a print job. If necessary, request that the job be resubmitted.

---

## Changing the Password or Authorization Level

This procedure lets you set the authorization level of the person that is working on the printer. It also allows you to change the user-authorization password. Access to higher user-authorization levels is password protected. If you do not know the current password, access to the requested user authorization level is denied.

The different levels of authorization are:

- **Operator:** No password is required for access to Operator procedures.
- **Key Operator:** The Key Operator has access to all functions except those that are related to the service and repair of the printer. The following tasks require at least a Key Operator level of authorization:
  - Configure Printer
  - Configure Attachments
  - Configure Pre/Postprocessor
  - Traces
  - Calibrate Touch Sensitive Screen
  - Front Face
- **Customer Engineer:** The service representative has access to all functions of the printer. The following tasks require Customer Engineer authorization:
  - Service Actions
  - Configure Control Unit Trace within Traces

### Initial Operation

When the printers are shipped from the factory, they are set for the **Key Operator** user authorization level, which makes all procedures except service-related activities available. The factory-set password is “all blanks”. That is, if you change the user level to the **Operator** level and then want to go back to the **Key Operator** level, simply **SELECT** the **OK** pushbutton on the keyboard window when it appears without entering any data.

If you want to maintain a **Key Operator** authorization level, IBM recommends that you establish a new password for the **Key Operator** when the installation is complete. If you treat all operators as key operators, then leave the current “all blanks” password as it is.

If you forget or lose the current **Key Operator** password, the system accepts a fixed, alternate password for that level. Obtain this alternate password from your system administrator.

To Change the Password or Authorization Level, do the following:

1. From the **Options** pull-down menu, **SELECT Password**.

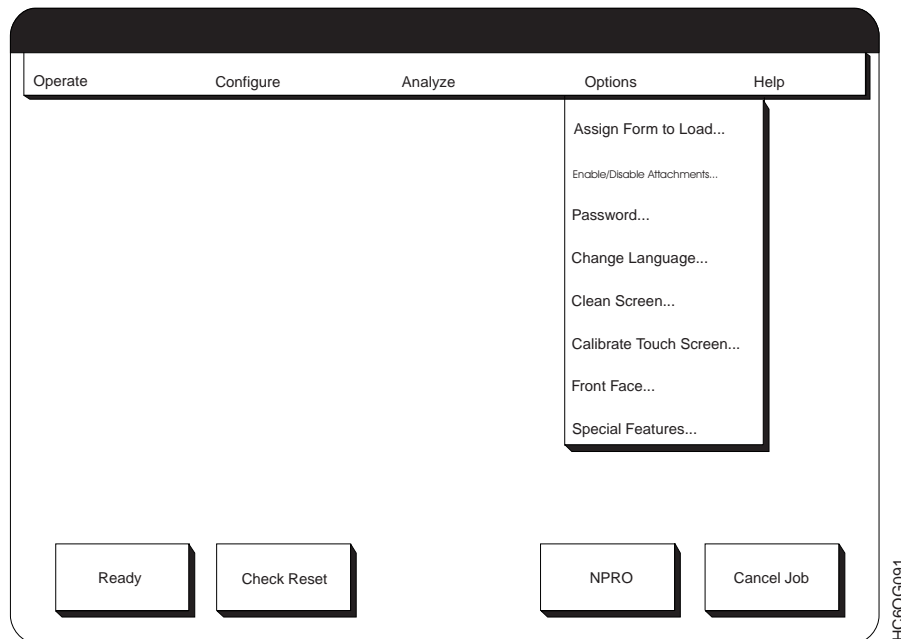

Figure 23. Options Pull-Down Menu

2. To change the Authorization Level, **SELECT** the Authorization Level to which you wish to change.  
If you are not changing to the **Operator** level, then the **Password Keypad** window appears. Enter the password, and **SELECT** the **OK** pushbutton.
3. To change a password, first **SELECT** the Authorization Level you wish to change. Then do the following:
  - a. If you select a level that the system is not currently in, the **Password Keypad** window appears. Enter the password, and **SELECT** the **OK** pushbutton.
  - b. When the **Password** window returns, **SELECT** the **Change** pushbutton. The **Password Keypad** window appears.
  - c. Enter the new password and **SELECT** the **OK** pushbutton to change the password.  
If you decide not to change the password, **SELECT** the **Cancel** pushbutton.



## Checking for a Front-Facing Page

Do this task when your system uses the eject-to-front-facing-page facility or it is configured on the printer. Also, do this when you need to tell the printer that the next page to be printed is a front-facing or a back-facing page.

For example, the following situations might require you to perform this task:

- Loading a new form name in the printer
- Reloading forms after you clear a forms jam
- Restarting printing operations in the middle of a job.

The eject-to-front-facing-page facility places a blank page between jobs that have an odd number of pages. This ensures that a job that requires a certain folding pattern are printed correctly. A good example is a print job that is to be folded like a book, where the cover and all odd-numbered pages are to be printed on front-facing pages.

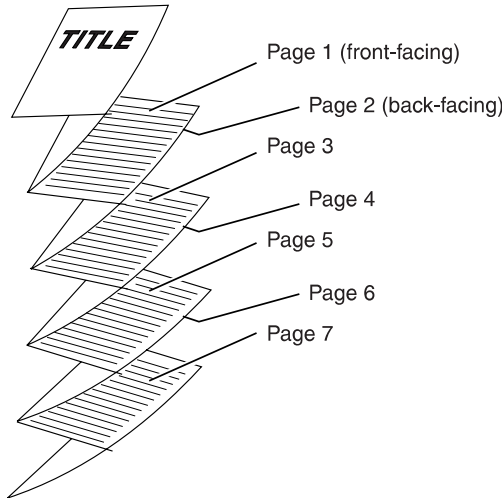
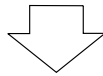
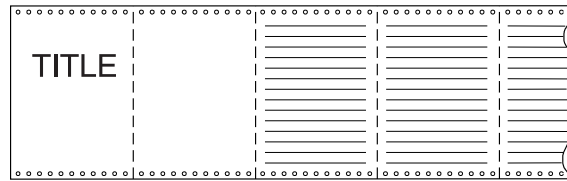

Page 3 is "Face Up." Page 4 is "Face Down."

R4CO0076

The printers do not count pages. However, after you inform the printer what the orientation (front facing or back facing) of the first page of a job will be, the printer simply switches a pointer back and forth in its memory to remember the page orientation. Therefore the printer is able to determine, at the end of a job, that the job contained an even or odd number of pages.

**Next Page is Front Facing** is the power-on default condition. If you do not use the **Front Face** procedure, all print jobs are started or restarted using that default, which may not be aligned with the fold direction. The determination of whether to insert a blank page is still made even if the fold direction is incorrect.

### Notes to the Operator:

1. To use the eject-to-front-facing-page facility, you must set the printer configuration item "Eject to Front Facing" to **Yes** (use the **Configure Printer** procedure on the **Configure** pull-down menu).
2. Perform this task only for fan-fold forms that are to be stacked in the printer stacker or re-folded in a postprocessing device. This task has no benefit if the forms are processed by a postprocessing device that separates each page, either by bursting or cutting processes the forms.
3. In duplex mode use this procedure only on Printer 1.

#### This procedure assumes the following:

- The **Front Face** Display Touch Screen window appears with the text message Next Page is Front Facing.
- The **Check Forms Alignment** procedure has been completed (see "Checking the Forms Alignment" on page 84).

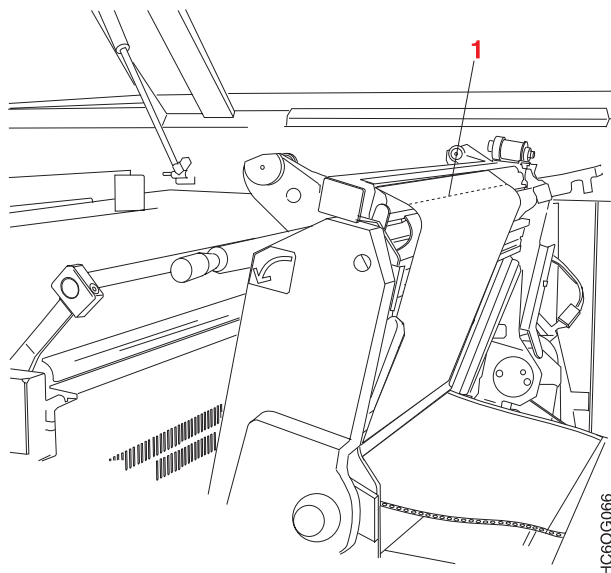

To check for a front-facing page, do the following:

1. Ensure that the forms perforation is aligned with the correct forms length (see "Checking the Forms Alignment" on page 84).
2. Look at the direction of the forms fold at the first fold (1) *before* the forms perforation at the length alignment mark. If you cannot see the perforation, raise the transfer station; the perforation should be near the top of the raised transfer station.
  - If the fold is an *up* fold, the next page printed is a back-facing page.
  - If the fold is a *down* fold, the next page printed is a front-facing page.

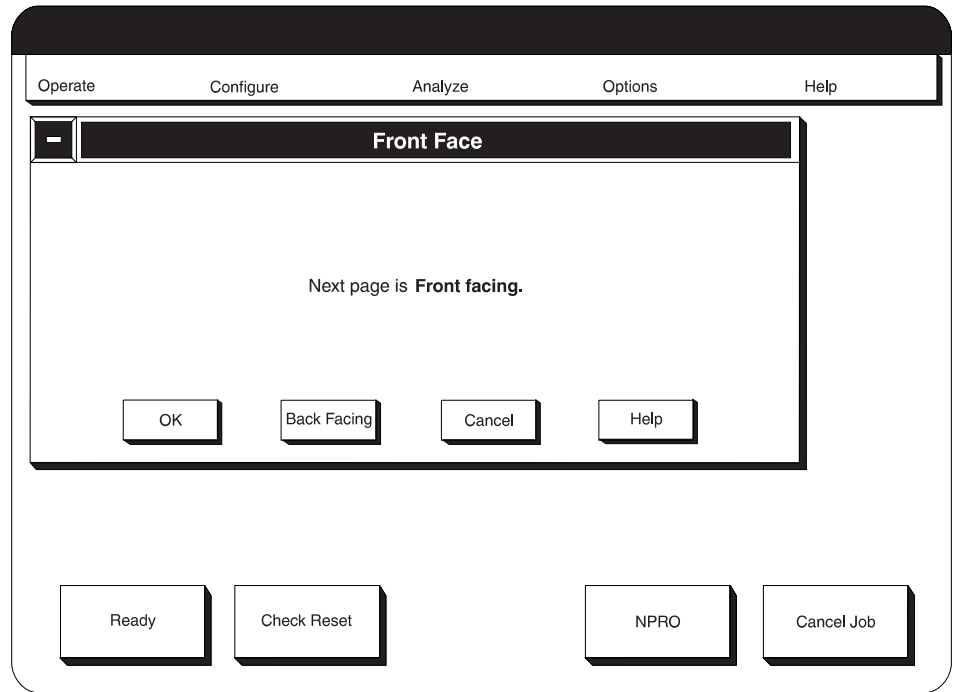

3. If the fold direction is the way you want, do the following to start or continue a print job:
  - a. If necessary, **SELECT** the **Back Facing** pushbutton.
 

The message text on the window changes to Next Page is Back Facing and the **Back Facing** pushbutton text changes to **Front Facing** text. **SELECTING** that pushbutton again changes the message and pushbutton text back to where it was originally.
  - b. **SELECT** the **OK** pushbutton.
 

This sets the front/back pointer in the printer memory.
4. If the fold direction is *not* the way you want, do the following to start or continue a print job:
  - a. Advance the forms one page by **SELECTING** the **NPRO Page** procedure from the Display Touch Screen **Operate** pull-down menu.
  - b. If necessary, **SELECT** the **Back Facing** pushbutton to set the window message text to agree with the fold direction.
 

The message text on the window changes to Next Page is Back Facing. The **Back Facing** pushbutton text changes to **Front Facing** text.

**Note:** Selecting that pushbutton again changes the message and pushbutton text back to where it was originally.
  - c. **SELECT** the **OK** pushbutton.

---

## Checking the Forms Alignment

Do this task when you see a CHECK FORMS ALIGNMENT message or whenever you load, splice, or adjust forms.

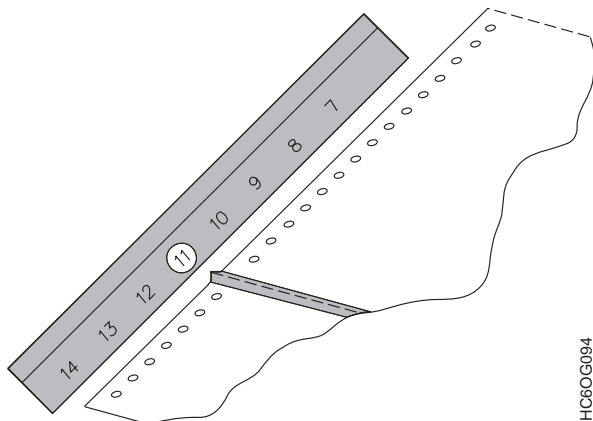

1. At the upper rear transfer station tractor cover plate, ensure that the forms perforation is aligned with the correct forms length.
2. If the forms perforation is not aligned correctly, do the following:
  - a. Use the **Forms Feed** key on the Printer Control Panel to adjust the position of the perforation.
3. If you are using the on-board stacker, ensure that the **Forms Set** indicator on the Printer Control Panel is set to match the fold direction of the first fold perforation *below* the perforations on the forms guide.
4. If you are doing this procedure as a step in a **Printer Error** or **Intervention Required** procedure, continue with the steps in that procedure.
5. If you are doing this when you load, splice, or adjust forms, **SELECT** the **Ready** pushbutton on the Display Touch Screen window for the affected printer to continue processing.

---

## Checking Print Quality

Print quality problems are commonly caused by:

- Paper chads in the transfer corona
- Dirty corona wires
- Photoconductor scratches
- Adhesive labels in the forms path or on the photoconductor drum.

**Note:** Adhesive labels are supported only in simplex mode.

Check print quality at least once each shift, and also when you do any of the following:

- Print on labels or preprinted forms
  - Change from one kind of form to another
  - Print bar codes.
1. Inspect a sampling of printed output. To print a variety of samples, do the following:
    - a. From the **Options** pull-down menu, disable attachments by using **Enable/Disable Attachments**.
    - b. From the **Analyze** pull-down menu on the Display Touch Screen, **SELECT** the **Print Samples** procedure. The **Print Samples** window appears.
    - c. **SELECT** the type and number of samples you wish to print, and **SELECT** the **Print** pushbutton.
  2. In the printed output, check for the following:
    - Is the print dark enough?
    - Is the printing clear and easy to read, especially close to edges, perforations, holes, and cuts?
    - Is print quality uniform across the page?
    - Are spots or blank areas on every page, or on every other page?

**Important:**

Many print quality problems are directly related to the kind of forms that are being used and the application that is being processed. If a particular form or application regularly produces unsatisfactory output, refer the application owner to the *Forms Design Reference for Continuous Forms Advanced Function Printers*. This publication contains detailed information about selecting forms and designing applications for use with continuous-forms printers.

3. If the output shows any of the problems that are mentioned above, see Table 27 on page 266, and perform the actions that are detailed there.

## Cleaning the Oiler Belt

### Notes to the Operator On Cleaning the Oiler Belt

- For reliable printer performance, clean the oiler belt at least once each week.
- You need the following items to clean the oiler belt:
  - Lightweight cardboard (scraps)
  - Cloth or paper towels.
- It is not necessary to switch the printer power off during this procedure, but the printer should be disabled.



### CAUTION:

<70> The oiler belt, oiler wick roll, and their environments are *high-temperature* areas. Be very careful when working in these areas.

CAUT0100

1. **SELECT** the **Stop** pushbutton on the Display Touch Screen window for the affected printer.
2. Open the stacker end cover.

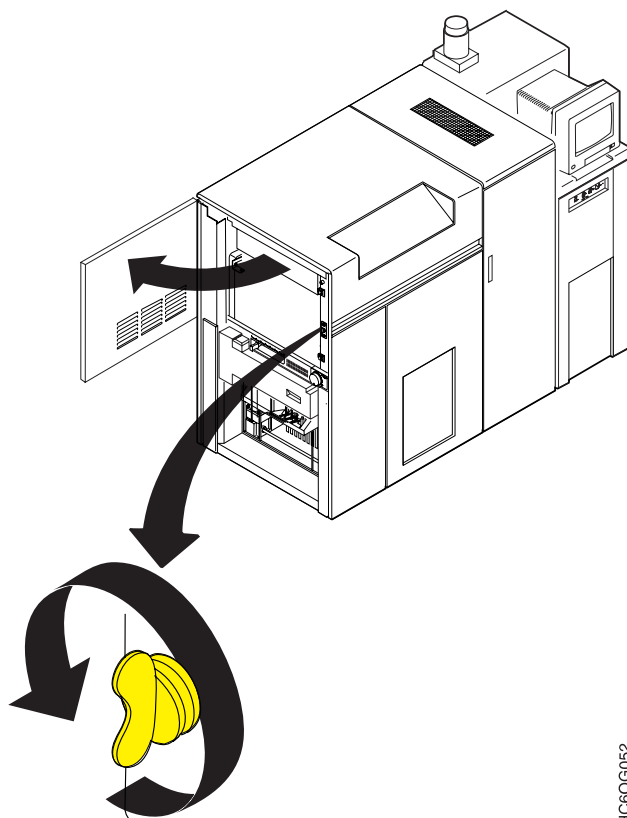

HC60G052

3. To release the oiler-belt gate, turn the wing nut *counterclockwise*.

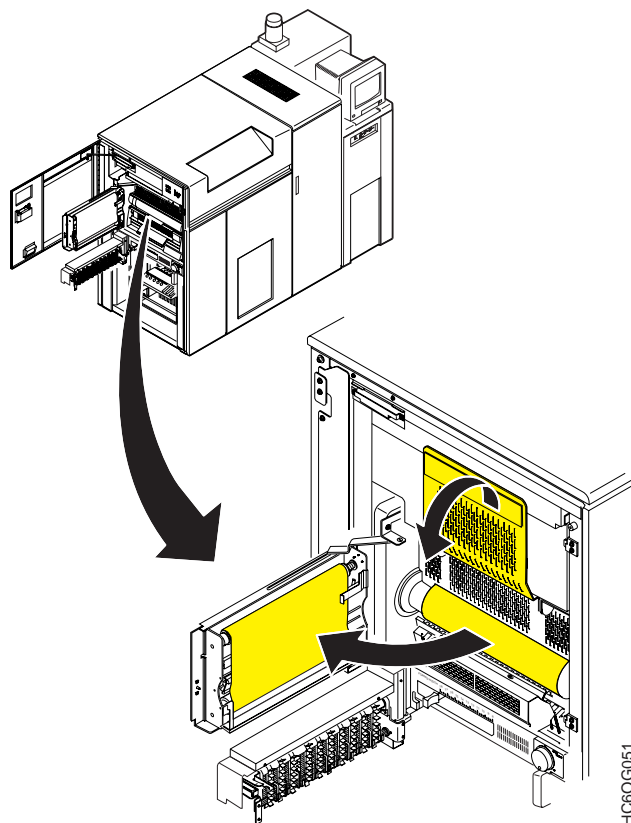

4. Open the oiler-belt gate.
5. Allow the oiler belt to cool for at least **10 minutes**.
6. Lower the hot roll shield.
7. Spread papers on the floor or place a wastebasket under the oiler belt.
8. Use a piece of lightweight cardboard to scrape paper dust and paper chads from the oiler belt.
9. Raise the hot roll shield.
10. Close the oiler-belt gate.
11. Turn the wing nut *clockwise* to latch the gate. Ensure that the gate is firmly latched.
12. Close the stacker end cover.
13. The fuser begins a warm-up cycle. To make the printer ready, **SELECT** the **Ready** pushbutton on the Display Touch Screen window.  
Printing resumes when the fuser completes its warm-up cycle.

---

## Cleaning the Printer

Clean the following areas of both printers once each day:

- Developer area
- Forms input area
- Transfer station area
- Stacker area
- Rear service area.

Clean the following area at least once each week:

- Oiler belt. See “Cleaning the Oiler Belt” on page 86 for instructions.

### Recommendations for Cleaning the Printer

- You may need to clean the printer more often, especially before and after printing labels.
- The following procedure specifies that you unload forms from the printer before you clean.
  - Unloading forms before you clean requires that you reload forms after you finish cleaning.
  - Loading forms is a time-consuming activity and requires flushing forms out of the entire forms path, then reloading and threading the entire forms path.
  - IBM recommends that for normal, once-per-day cleaning of the printer you leave forms loaded on the printer, and do the best job you can working around the forms to follow all of the cleaning steps. IBM also recommends that you do an additional cleaning when you load a new form type or when you have cleared the forms path.
- You should clean the printer only with a vacuum cleaner that is approved for toner applications.
- You need the following items to clean the printer:
  - Toner-certified vacuum cleaner
  - Cloth or paper towels.

To clean the printer, do the following:

1. Disable the host attachments. See “Enabling and Disabling Attachments” on page 63 for details.
2. Separate the forms at a perforation below the forms guide on the transfer station.
3. Move the static brush to the left with your hand so that the forms fall back into the input area. Ensure that forms do not cover the end-of-forms sensor in the input area.
4. Advance the forms by **SELECTING** the **NPRO** pushbutton on the Display Touch Screen main window.  
The END OF FORMS 078A message appears on the Display Touch Screen.

**Note:** NPRO is not operable if the **Thread/Align Forms** procedure window appears.

5. **SELECT** the **NPRO** pushbutton again.



In duplex mode, the forms move through both Printer 1 and Printer 2 to either the stacker on Printer 2 or to a postprocessing device behind Printer 2. In simplex mode, the forms move through the printer to the stacker or to a postprocessing device behind the printer.

If forms have moved to a printer stacker, go to step 6.

If forms have moved to a postprocessing device, go to step 7.

6. Unload the stacker. See “Unloading the Stacker” on page 169. Perform the **Shutdown** procedure.
7. Switch off power to the printer. See “Controlling the System Power” on page 56 for details.

**Attention!**

Damage to the printer can occur if you do not turn printer power off before you use the vacuum cleaner.

8. Plug a toner-certified vacuum cleaner into a 110 V ac outlet near the printer.

## DEVELOPER AREA:

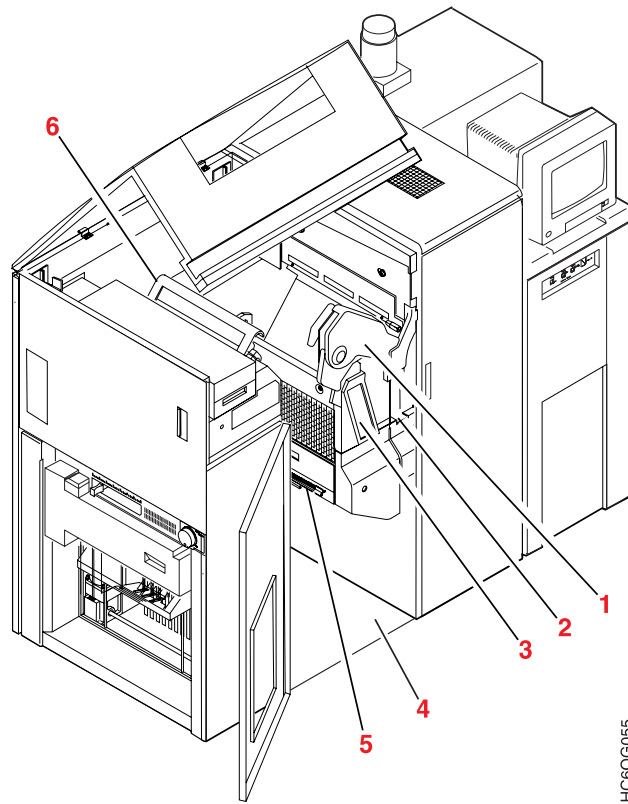

9. Open the left top and front center left covers of the printer.

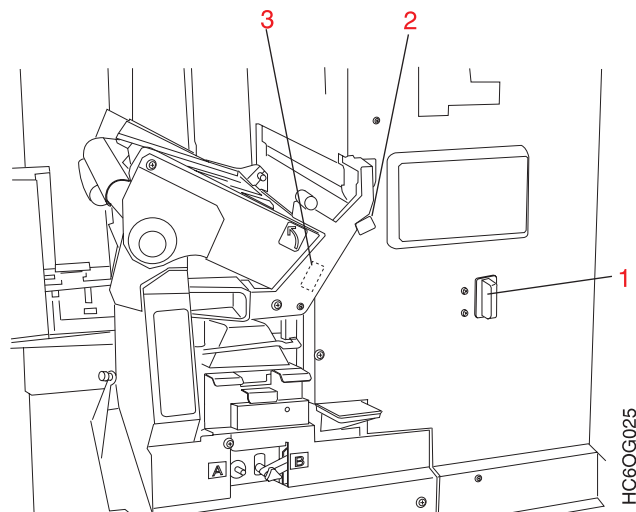

10. The printer has three coronas that you need to clean. The charge corona (1) and the pre-clean corona (2) are in the developer area; the transfer corona (3) is in the transfer station area.

To clean the charge (1) and preclean (2) coronas, do the following:

**Important Note About the Coronas**

There is no device to prevent you from pulling out the corona wires. Be careful not to break the thin wires and tiny retractor springs inside the corona.

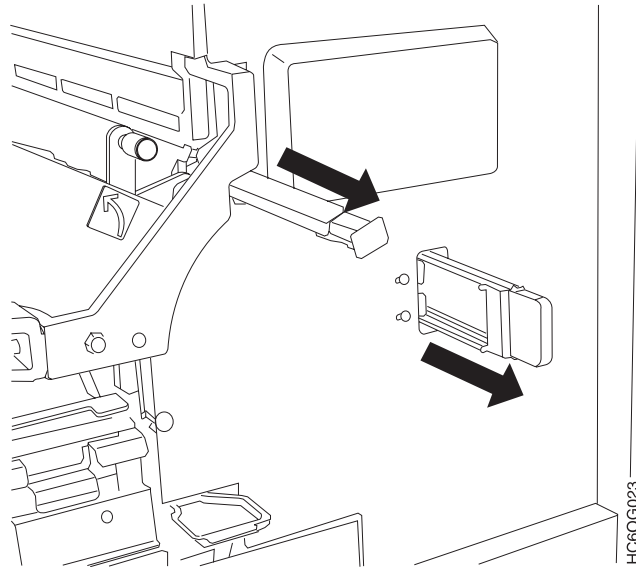

- a. Pull each white corona toward you until it is *almost* out of its track. A brush inside the corona housing cleans the corona as you pull it out and then push it back in.
  - b. Gently push each corona back into place. Ensure that you have pushed the corona in completely.
11. Use a cloth or paper towel to wipe away any paper dust, toner, or other debris from the developer area.
  12. Close the front center right cover of the printer.

**Important**

The front center right cover *must* be completely closed whenever the printer is running. Light entering the printer can significantly reduce print quality.

## FORMS INPUT AREA:

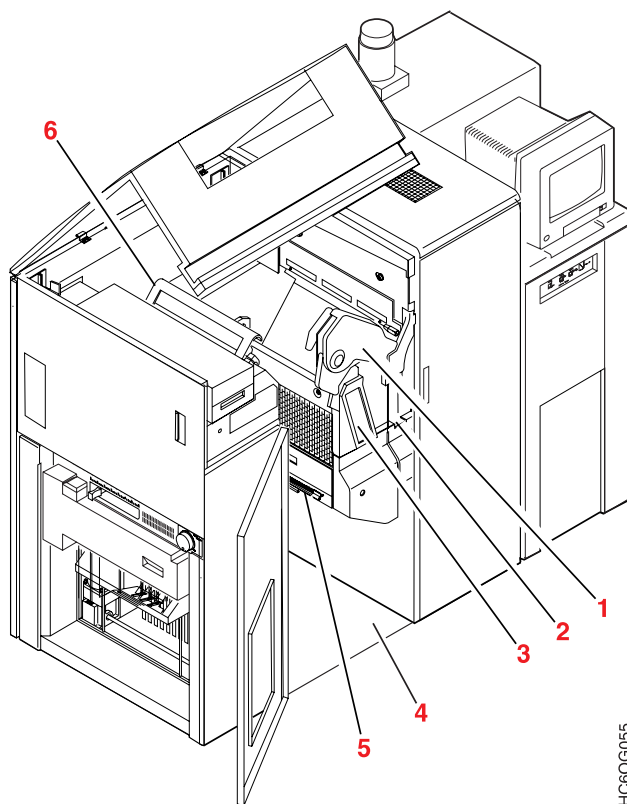

HC60G055

13. Open the top left and front left center covers of the printer, if they are not already open.
14. Use a toner-certified vacuum cleaner to clean the:
  - Input area (4)
  - End-of-forms sensor (5)
  - Tension arm (6)

## TRANSFER STATION AREA:

### Attention!

Use care when you clean behind the transfer station. Open the transfer station to its full upright position to ensure that the drum is completely covered.

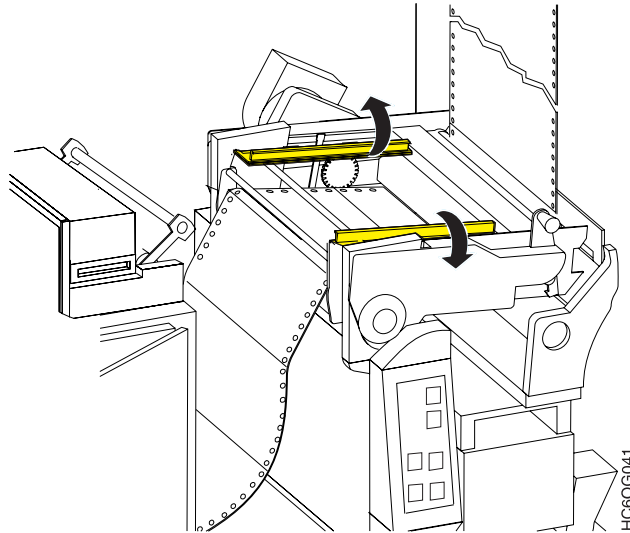

### CAUTION:

<71> The tractor covers are spring-loaded and can pinch if they snap shut unexpectedly.

CAUT0101

15. Open the upper tractor covers.
16. Use a soft cloth to clean the upper tractor jam sensor (the glass window under the upper front tractor cover). If necessary, use a pencil eraser to remove forms residue.
17. Use a vacuum cleaner to remove dust and debris around the upper tractor pins.
18. Close the upper tractor covers.
19. Clean the static discharge brush on the transfer station.

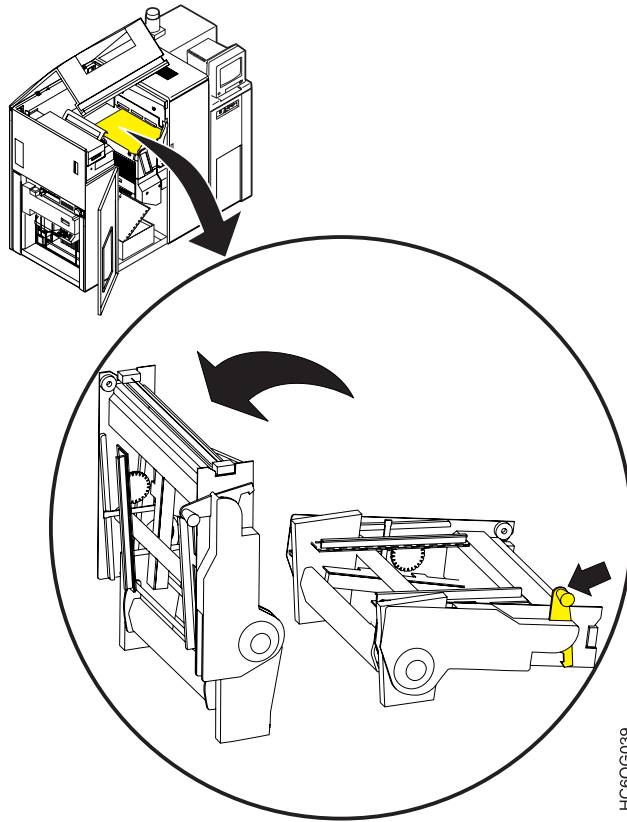

HC60G039

20. Raise the transfer station.

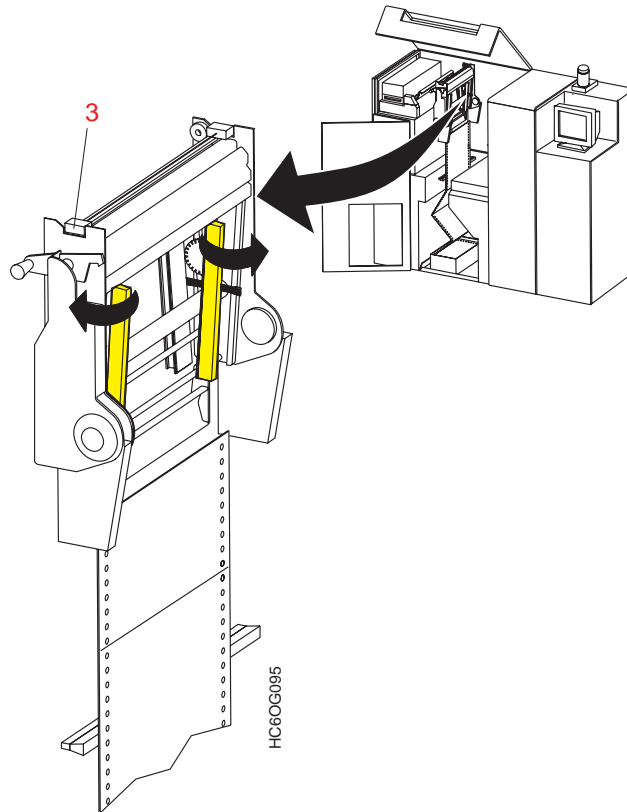

21. Open the lower tractor covers.
22. Vacuum the lower tractor pins to remove forms dust and debris.
23. Close the lower tractor covers.

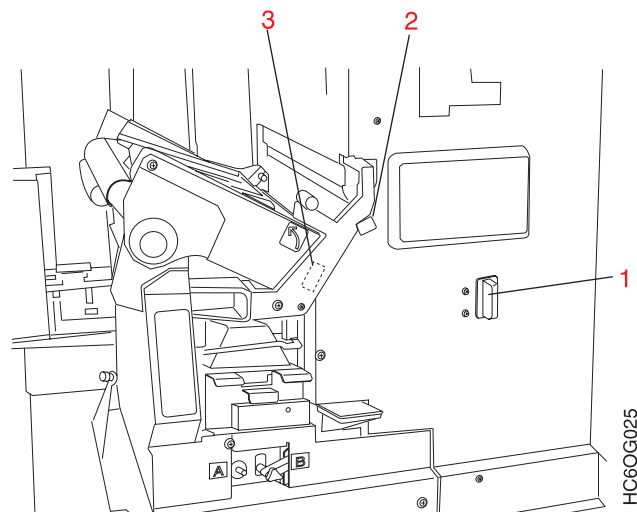

24. To clean the transfer corona (3), do the following:

**Important Note About Cleaning the Coronas**

There is no device to prevent you from pulling out the coronas. Be careful not to break the thin wires and tiny retractor springs inside the corona assemblies.

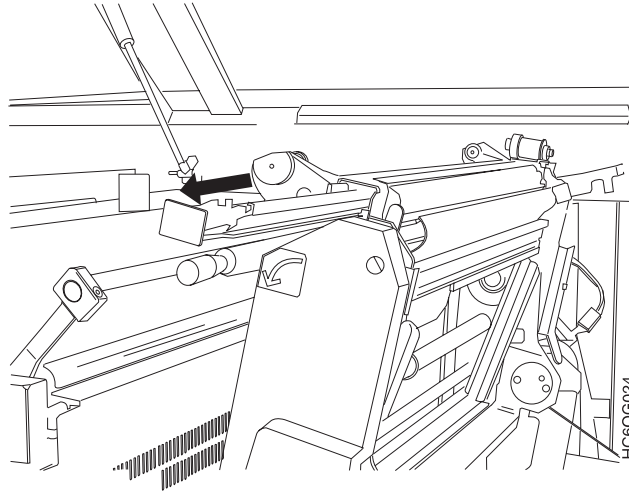

- a. Gently pull the white corona toward you until it is *almost* out of its track. A brush inside the corona housing cleans the corona.
  - b. Gently push the corona back into place. Ensure that you have pushed the corona in completely.
25. Clean the brushes below the transfer station.
  26. Gently lower the transfer station toward the photoconductor drum and latch it using the Transfer Station Control Lever. See "Transfer Station Control Lever and Tractor Control Levers" on page 25 for details.
  27. Close the top left and front center left covers of the printer.



## STACKER AREA:

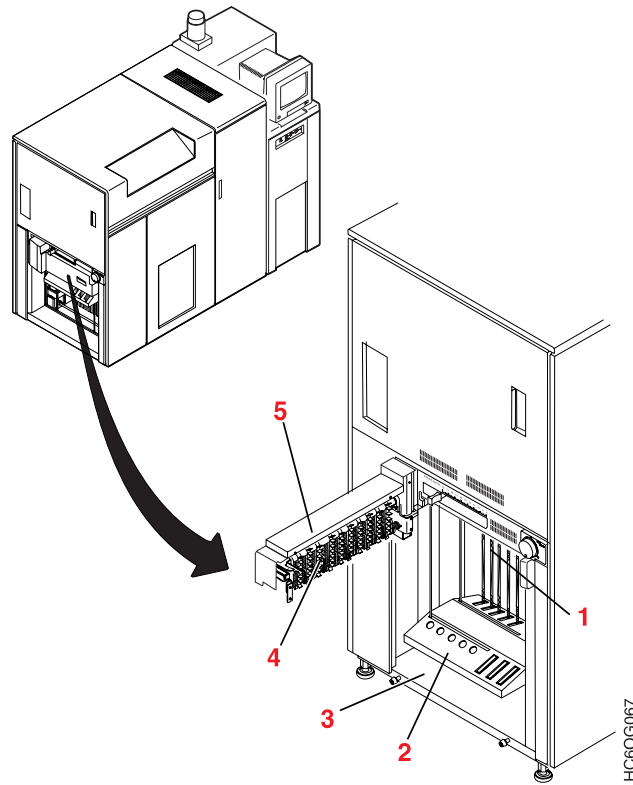

28. Open the stacker gate (5) if the buffer/flipper unit or an installed postprocessing device does not interfere.
29. Use a toner-certified vacuum cleaner to clean paper dust, chads, and other debris from the following:
  - Pendulum (1)
  - Stacker table (2)
  - Stacker floor (3)
  - Finger belts (4)

If you cannot open the stacker gate completely because of interference from the buffer/flipper unit or an installed postprocessing device, open the gate as wide as you can. Clean as much of the area as you can reach.

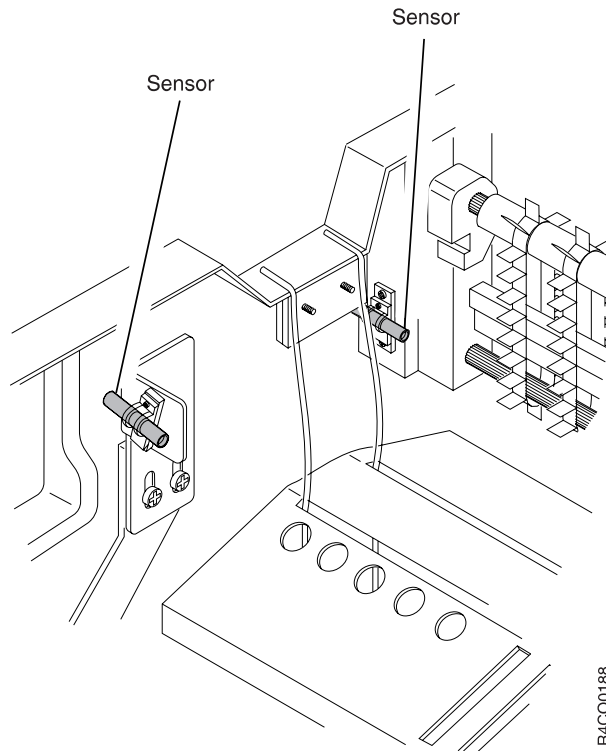

R4CO0188

30. Use a soft cloth to clean the six stacker jam sensors and two mirrors.

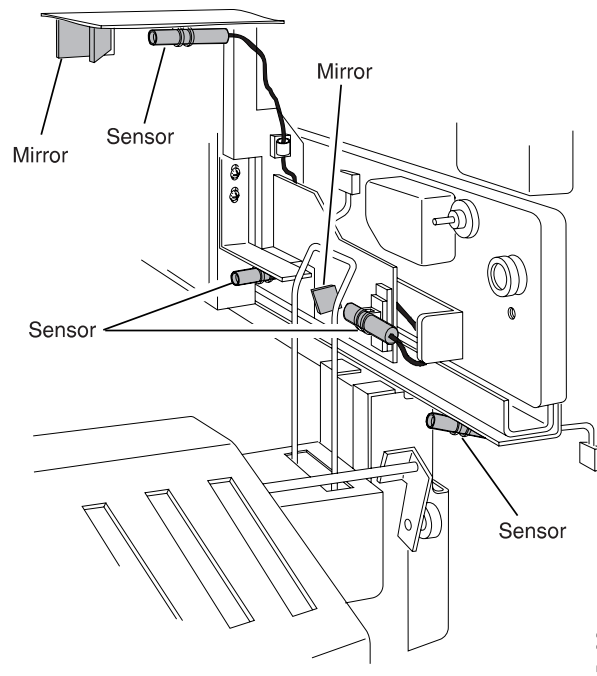

R4CO0237

31. Close the stacker gate.

**FUSER AREA:**

32. Open the front left cover.
33. Use a soft cloth or paper towel to wipe up excess fuser oil on any surfaces.
34. Use a vacuum cleaner to remove chads, paper, or debris from the area.
35. Close the front left cover.

**REAR SERVICE AREA:**

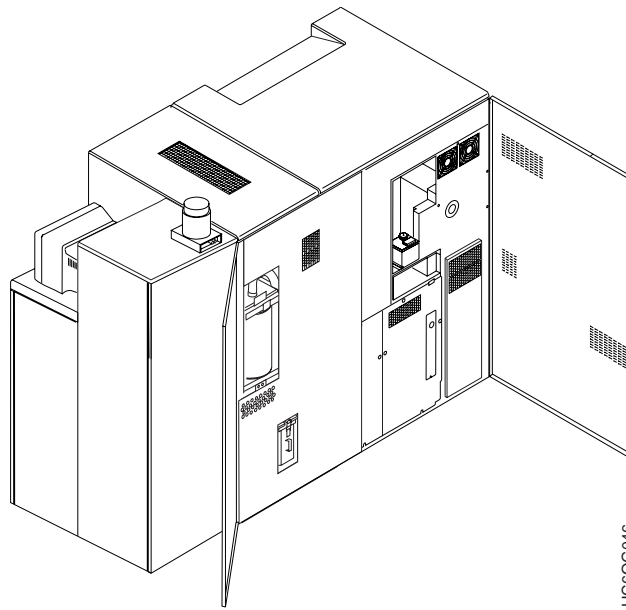

36. Open the rear center and right covers of the printer.

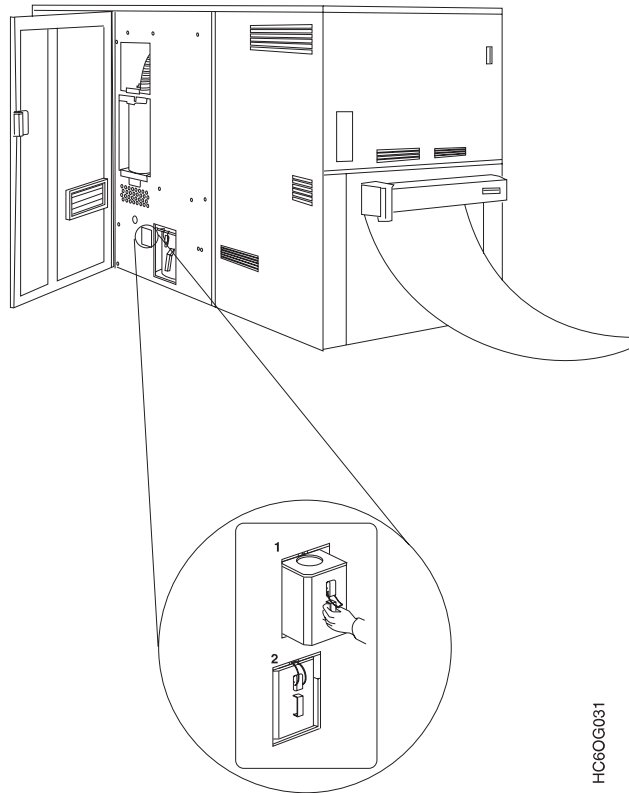

HC66G031

37. Remove the Toner Collector Case.
38. Vacuum any spilled toner from around and under the Toner Collector Case.
39. Use a soft cloth to clean the *inside* cover surfaces in the rear service area.
40. Vacuum any paper dust, chads, and other debris from the fuser oil reservoir area.
41. Close all covers securely.
42. Use a soft cloth that is moistened with water to clean the covers and panels.

**Important Note About Cleaners**

Do not use commercial cleaners that might contain ammonia, solvents, or other volatile chemicals. The vapors from these cleaners can cause chemical reactions that result in reduced print quality.

43. Power on the printer. See “Controlling the System Power” on page 56.
44. Load forms into the printer, if necessary. See “Loading Forms (Simplex or Dual Simplex Mode)” on page 102 or “Loading Forms (Duplex Mode)” on page 115 for details.  
This step is not required if you did not unload forms before starting this procedure.
45. Enable the host attachments, if necessary. See “Enabling and Disabling Attachments” on page 63 for details.

---

## Connecting an Accessory to the Operator Alert Contacts

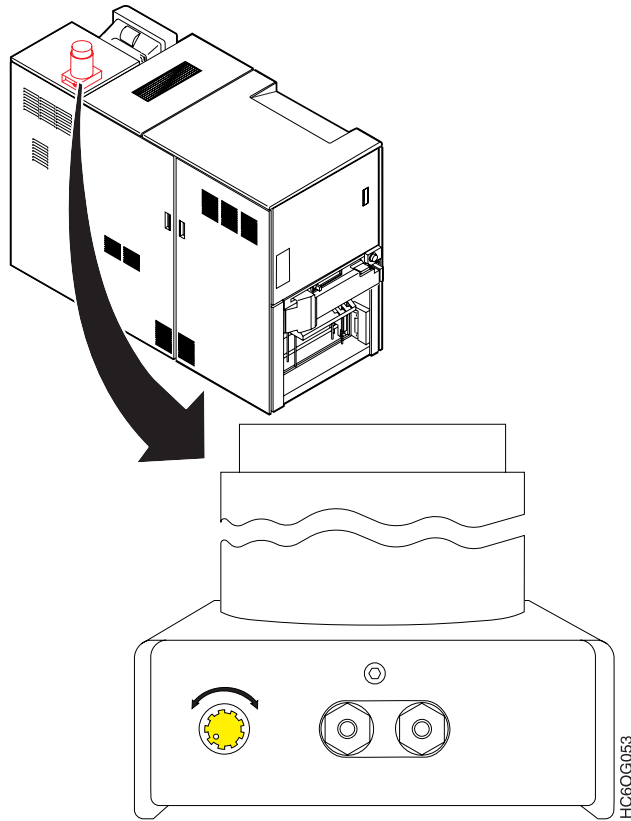

This function provides you with a set of external contacts that allow the hook-up of an alert signal of your choice.

The post accepts the following:

- Standard dual or single banana plugs
- Leads that are terminated with spade lugs
- Stripped, bare wire leads.

The recommended voltage for the posts is 12 V dc, at a maximum current of 5 amps.

**Note:** There is an internal 5-amp fuse.

Voltage is not present at the binding post. You are responsible for supplying power to run any external device. The two contacts of the binding post are connected together with the closing of a relay contact. The relay turns on only when the operator alert lamp is operating during an error condition. To reset or turn off the relay, press the **Check Reset** switch on the Display Touch Screen window for the affected printer.

---

## Loading Forms (Simplex or Dual Simplex Mode)

Do this task when any of the following situations occur:

- When you see the END OF FORMS 078A message
- You need to change forms
- When you are prompted by a forms jam recovery procedure step.

This section provides step-by-step instructions for loading forms in a Model ES1 printer or Models ED1/ED2 in dual simplex mode. "Loading Forms (Duplex Mode)" on page 115 contains instructions for loading form in an ED1/ED2 printing system in duplex mode. These instructions are for loading boxed, continuous forms that are loaded at the forms input area.

If preprocessing or postprocessing devices, or both, are used with the printing system, steps involving the continuous forms source or the final destination are different from the instructions given here. Because each preprocessing or postprocessing device is unique, you should use the specific instructions for the initial loading from a preprocessing device to the printer or forms handling in a postprocessing device following the printer that accompany the preprocessing or postprocessing device.

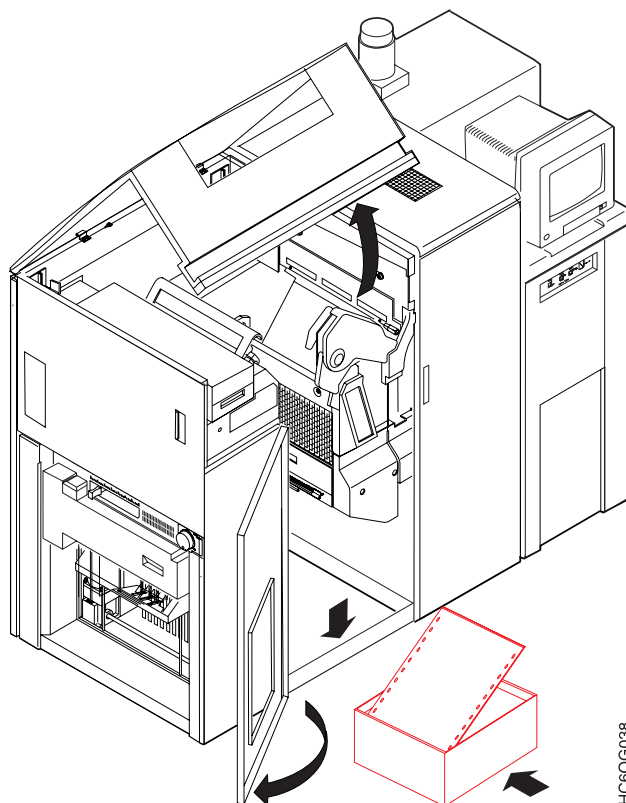



**CAUTION:**

<72> As you load forms, be careful to avoid injuries:

The tractor covers are spring-loaded and can pinch if they snap shut unexpectedly.

Moving forms, especially between the transfer station and the fuser entry area, can cause severe paper cuts.

CAUT0102

To load forms, do the following:

1. Open the top and center front covers if they are not already open.

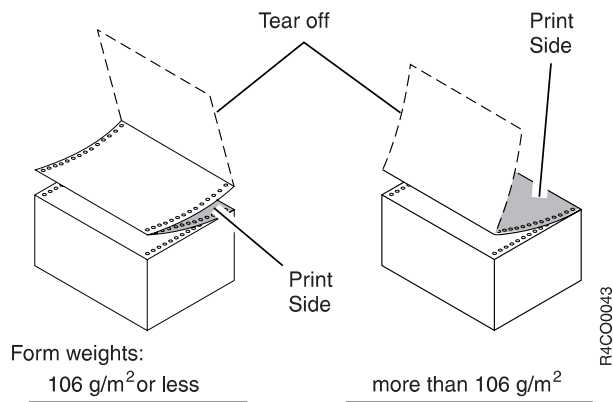

2. Open a box of forms and place the box in the input bin against the front edge.

## AT THE STACKER:

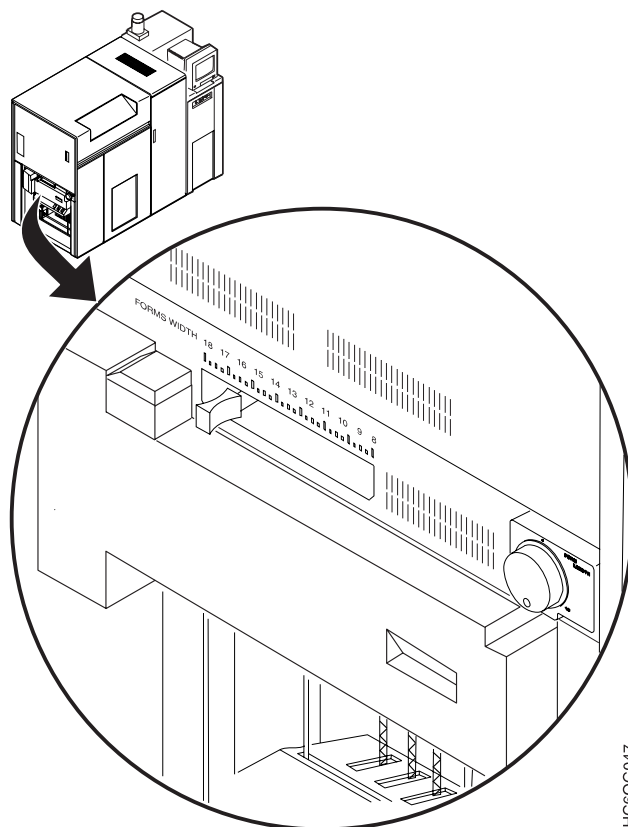

3. Slide the form width handle to the farthest left position (18 on the scale).
4. Turn the form length knob until two lights on the form length display indicate the correct length of the forms you are loading. For example, for 11½-inch-long forms, the light for 11 inches and the light for ½ inch are on.

**Note:** Forms that are greater than 14 inches long require postprocessing equipment.



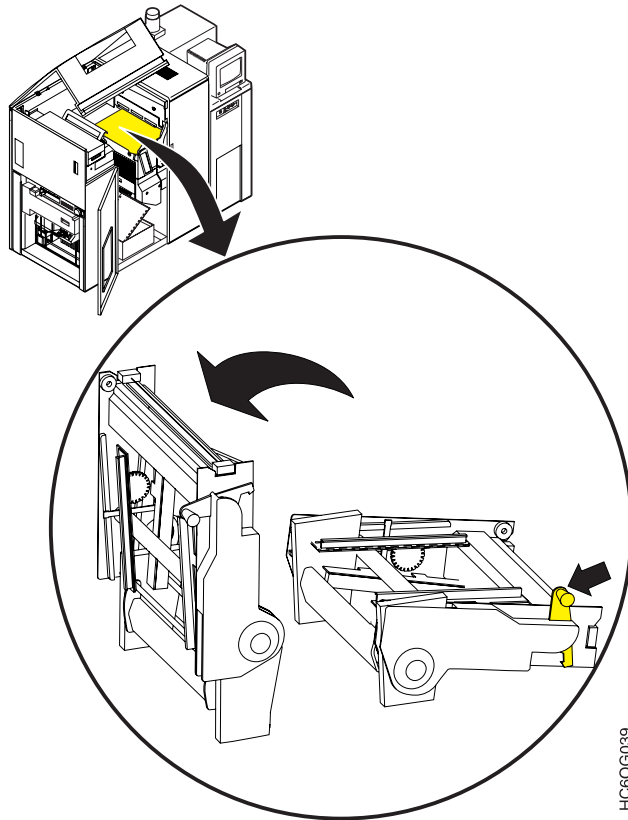

5. Release the transfer station latch and raise the transfer station to its upright position.

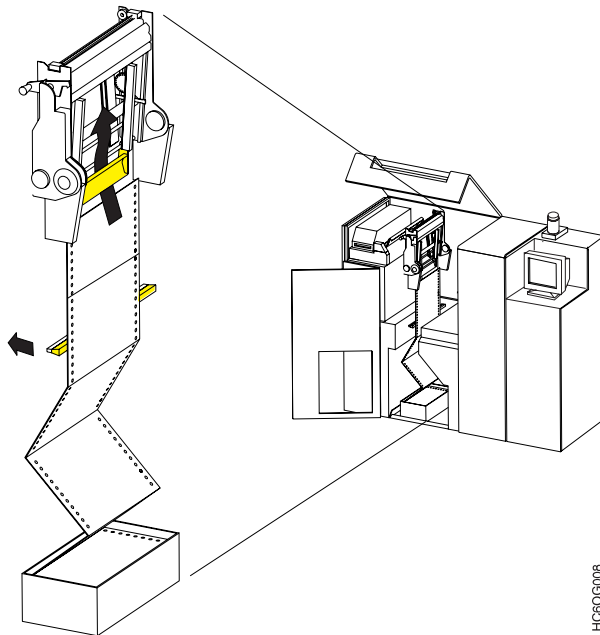

6. Swing the lower static discharge brush to the left.
7. Pull the forms to the right of the static discharge brush up to the transfer station.

8. Pull the forms over the forms guides.

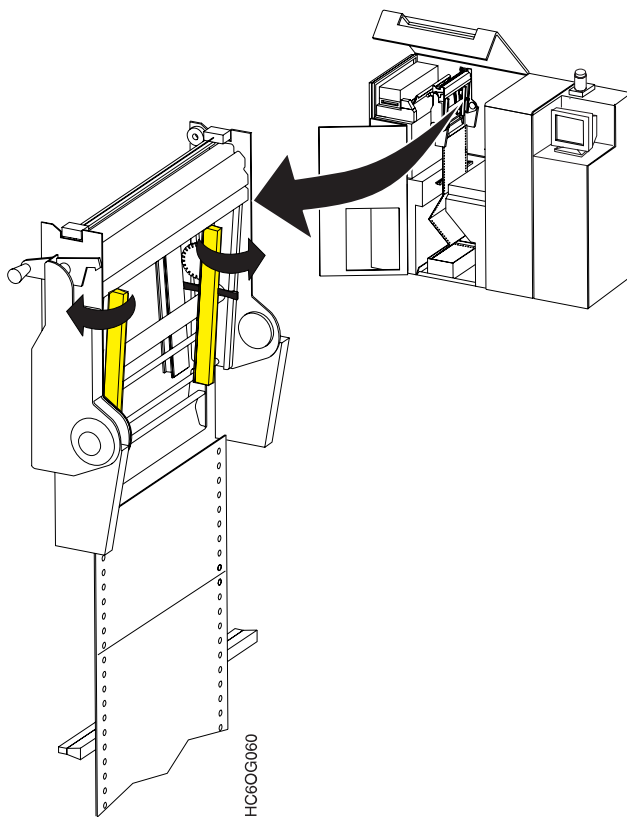

9. Open the two lower tractor covers.
10. Guide the forms under the transfer station brushes and up to the tractor area.
11. Place the forms on the front tractor pins and close the tractor cover.
12. Slide the blue rear lever on the adjustable tractor assembly until the rear tractor is approximately the width of the forms.
13. Place the forms on the rear tractor pins and close the rear tractor cover.

**Note:** Verify that the holes are aligned correctly.

14. Slide the rear blue lever on the adjustable tractor assembly until the forms are smooth and taut between the front and rear tractors.
15. Press down firmly on the blue lever to ensure the rear tractor assembly is locked in place.
16. Press and hold the **Forms Feed** button to feed approximately 1.3 meters (4 feet) of forms, enough to reach the tension arm.
17. Lower the transfer station and latch it.

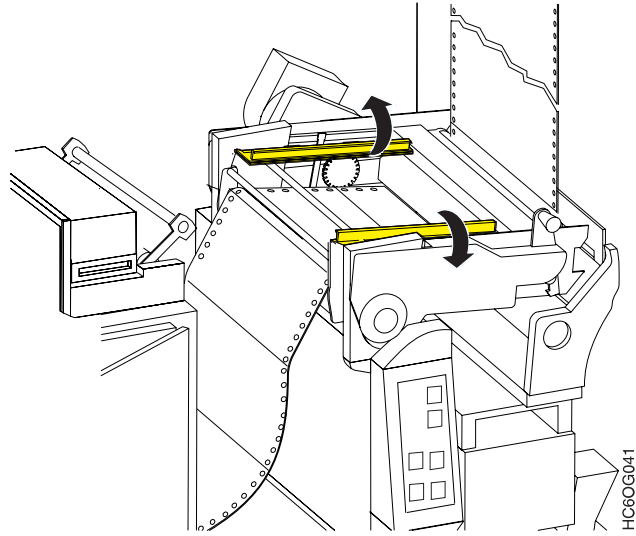

18. Open the two upper tractor covers.
19. Pull the forms tightly over the transfer station.

**Attention!**

If the forms are not pulled tightly over the transfer station, the photoconductor drum may be scratched. It is easily damaged and is *very* expensive to replace.

When the transfer station is in its upright position, the drum is automatically covered to prevent damage to the drum.

20. Place the holes of the forms on the top tractor pins.

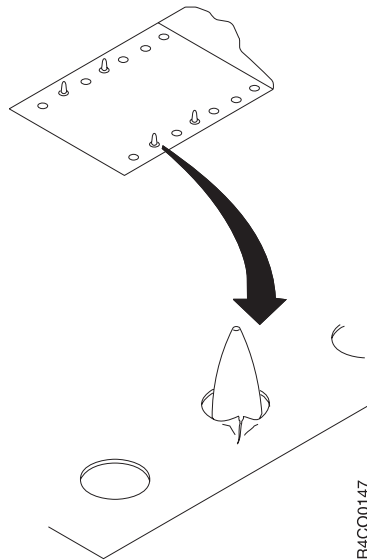

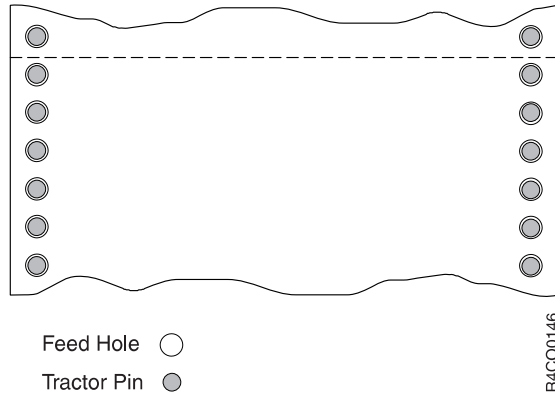

21. Ensure that the feed holes on the forms are centered on the tractor pins and not beginning to tear. If tearing is evident, adjust the rear tractor assembly until the feed holes are centered on the tractor pins.

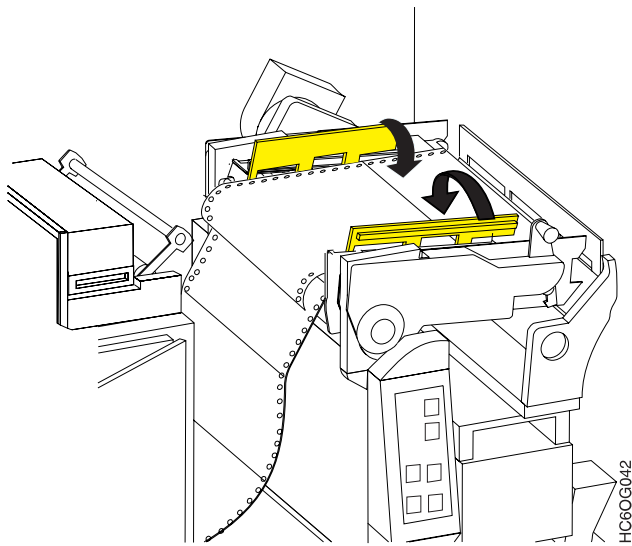

22. Carefully close the tractor covers.

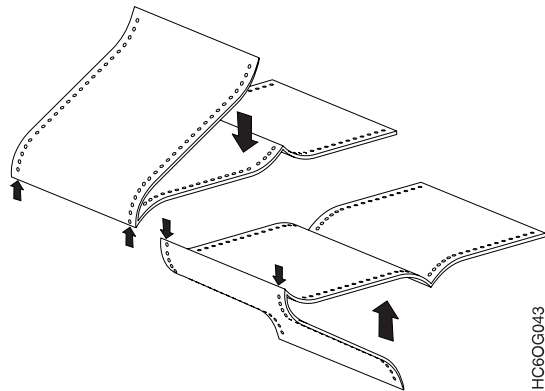

23. Fold the forms at the first perforation to make a double thickness.

**Note:** Use the original fold of the form. Do not fold the forms opposite to the original fold.

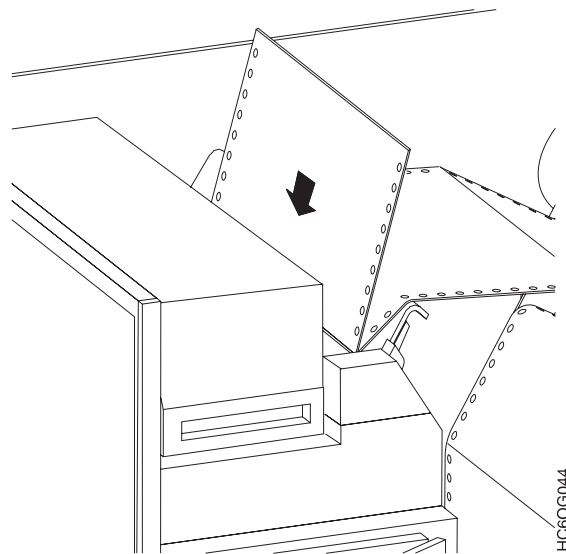

24. Pull the forms over the tension arm and feed the double thickness into the fuser.
25. Press and hold the **Forms Feed** button to feed several feet of forms into the stacker.

**Note:** If forms do not feed straight into the fuser, release the tension on the stacker feed rollers and straighten the forms.

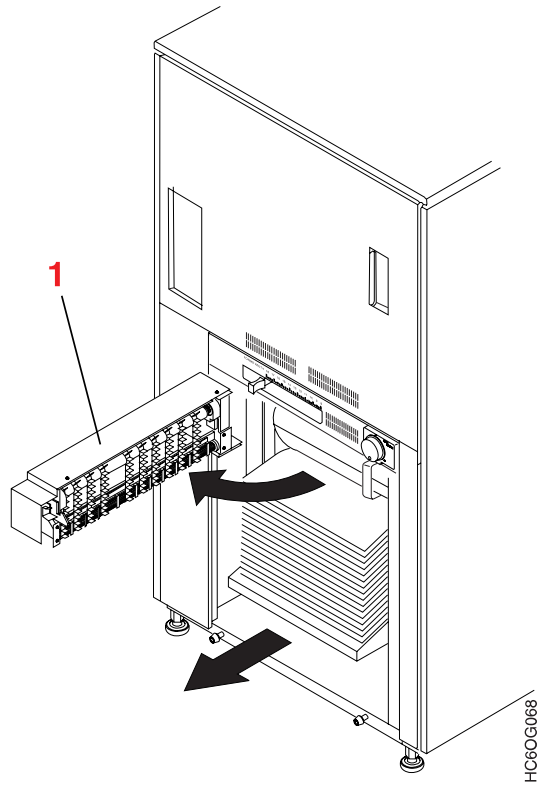

26. Open the stacker gate (1). Check that the forms are folding correctly (on their original folds). Press the **Forms Feed** button to feed additional forms into the stacker if necessary.

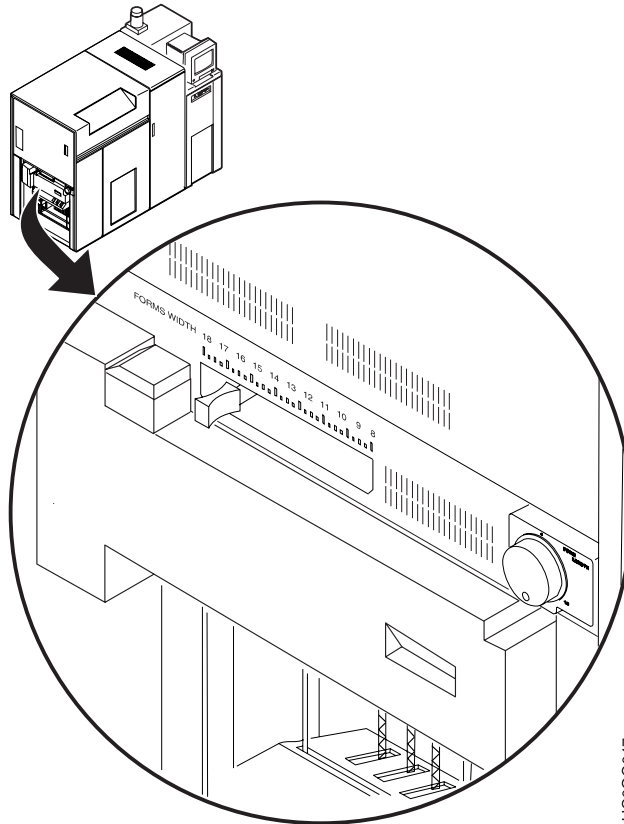

HC6OG047

27. Slide the stacker forms width handle close to the edge of the forms without wrinkling the forms.
28. Close the stacker gate.

**AT THE TRANSFER STATION:**

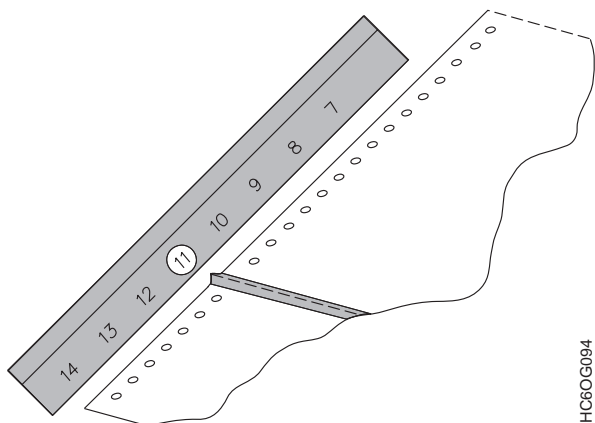

29. Press the **Forms Feed** pushbutton to line up a page perforation with the forms scale on the rear tractor cover until the perforation is aligned with the correct number for the length of the form you are loading.

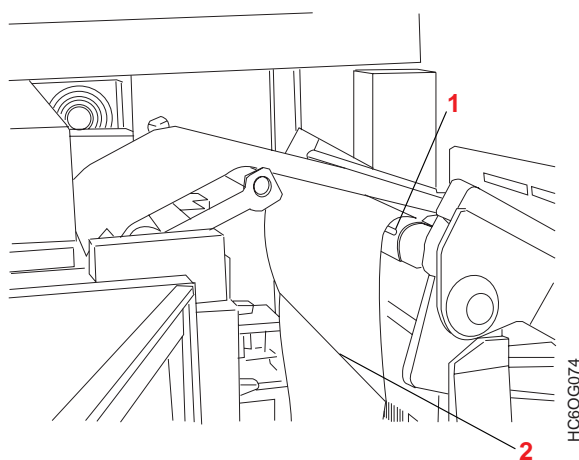

30. Determine the folding direction of the first perforation (2) below the slots (1) on the input forms guide.



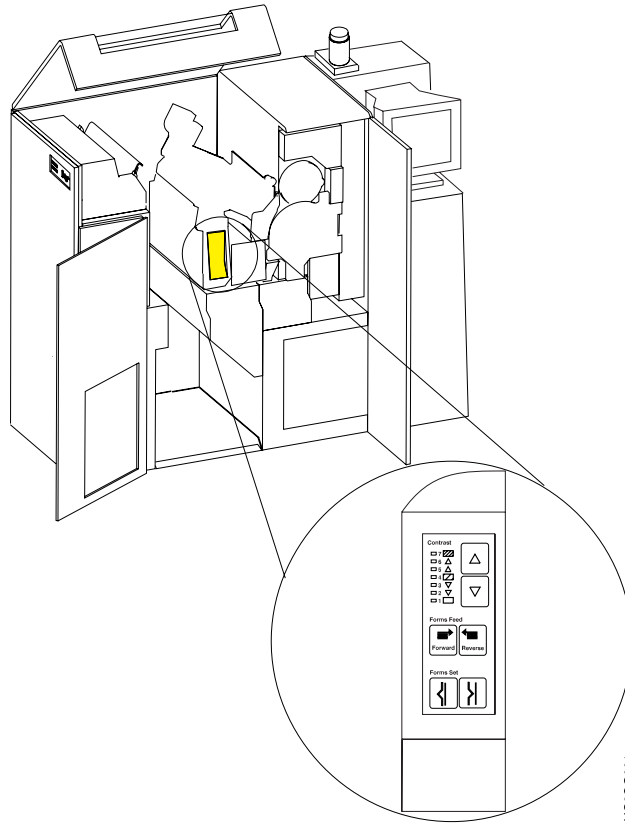

- If the fold is pointing to the left, press the forms set on the left.
  - If the fold is pointing to the right, press the forms set on the right.
31. Close the top and front covers.

AT THE DISPLAY TOUCH SCREEN:

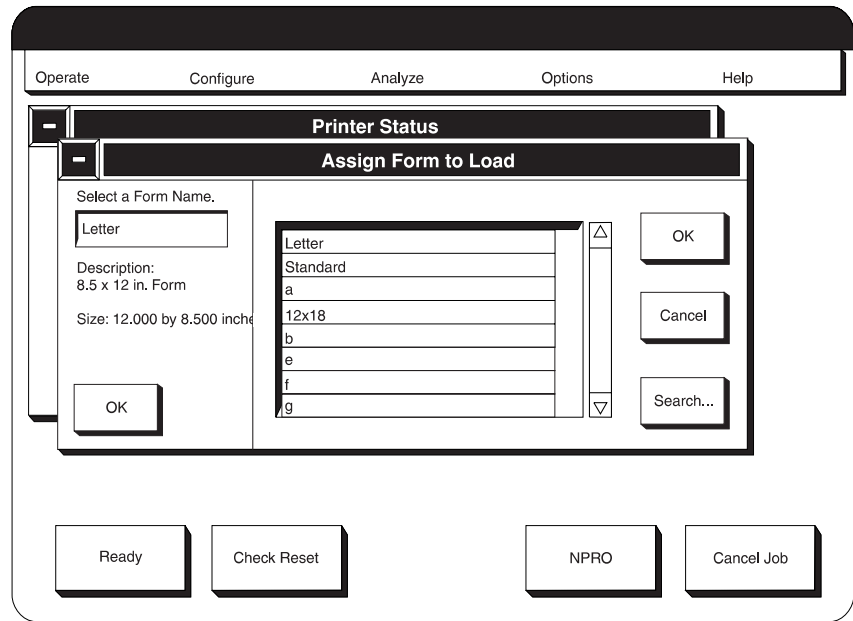

32. If you have changed to a different-size form, **SELECT** the **Assign Form to Load...** procedure from the **Options** pull-down menu.
33. If the form name in the **Select a Form Name** box is the form you are loading, **SELECT** the **Cancel** pushbutton. If the form name is not in the **Select a Form Name** box, **SELECT** the **Search** pushbutton.

A keyboard appears so you can enter the name of the form you are loading.

**Note:** The search function is case sensitive. That is, you must enter the form name *exactly*, including any capital letters, as it was originally defined.

34. When you have found the correct form name, **SELECT** the **OK** pushbutton.
35. If you have changed to preprinted forms or labels, check the forms alignment and the location of the print on the page. See "Adjusting the Print Position" on page 68.
36. If necessary, enable the channels.
37. **SELECT** the **Ready** pushbutton to continue.

## Loading Forms (Duplex Mode)

The ED1/ED2 duplex printing system is designed to have forms loaded through Printer 1, the Buffer/Flipper Unit, and Printer 2 for duplex printing.

This section provides step-by-step instructions for threading forms in duplex printing applications. “Loading Forms (Simplex or Dual Simplex Mode)” on page 102 contains instructions for loading forms for an ES1 printer or ED1/ED2 printers in dual simplex mode. These instructions are for loading boxed, continuous forms that are loaded at the forms input area of Printer 1, through the Buffer/Flipper Unit, Urge Unit, and Printer 2, to the output stacker of Printer 2.

If preprocessing or postprocessing devices are used with the printing system, steps involving the continuous forms source and the final destination are different from the instructions given here. Because each preprocessing and postprocessing device is unique, you should use the specific instructions for the initial loading from a preprocessing device to Printer 1 or forms handling in a postprocessing device following Printer 2 that accompany the preprocessing or postprocessing device.

Do this task when any of the following situations occur:

- You see the END OF FORMS 078A message
- You need to change forms
- You are prompted by a forms jam recovery procedure step.

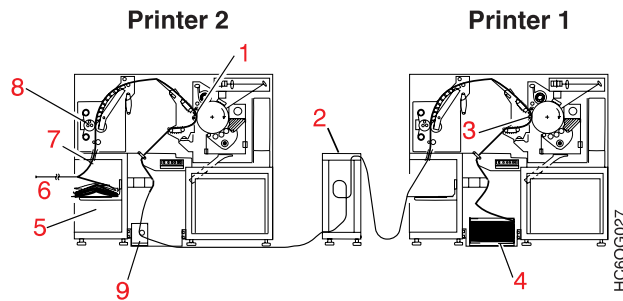

### CAUTION:

<72> As you load forms, be careful to avoid injuries:

The tractor covers are spring-loaded and can pinch if they snap shut unexpectedly.

Moving forms, especially between the transfer station and the fuser entry area, can cause severe paper cuts.

CAUT0102

To load forms, do the following:

1. Ensure that both Printer 1 and Printer 2 are in the Not Ready state before you begin this task.
2. Ensure that the Urge Unit is not running.

3. Do step 1 on page 103 through step 26 on page 110 under “Loading Forms (Simplex or Dual Simplex Mode)” and return here.  
You now have forms in the stacker of Printer 1.
4. Use the Forms Feed pushbutton on the Stacker Control Panel as necessary to advance enough forms to thread the Buffer/Flipper Unit, the Urge Unit, and Printer 2.
5. Thread the forms through the Buffer/Flipper Unit (2) (see “Threading the Buffer/Flipper Unit” on page 167).
6. Bring the forms under the control unit of Printer 2 to the Urge Unit (9).
7. Thread the Urge Unit.
8. Thread the forms through Printer 2 using steps 1 on page 103 through 37 on page 114 of Loading Forms (Simplex or Dual Simplex Mode).
9. Ensure that the paper in Printer 1 is aligned with the forms scale on the rear tractor cover.
10. Go to the Thread to Align menu to ensure proper alignment. See “Thread/Align Forms” on page 152.

---

## Adjusting the Stacker Table Height

When you change forms on the printer, it may be necessary to change the height of the stacker table. For example, going from very narrow to very wide forms could make it necessary to shorten the height of the output stack and thus reduce the weight of the stack you have to unload.

Raising the height of the stacker table reduces the height (and weight) of the output stack that causes the STACKER FULL message to appear on the Display Touch Screen. The shorter height of the output stack means you have to unload the stacker more often, but a short output stack weighs less than a taller stack.

Conversely, lowering the stacker table increases the height of the output stack and the STACKER FULL message appears on the Display Touch Screen less often.

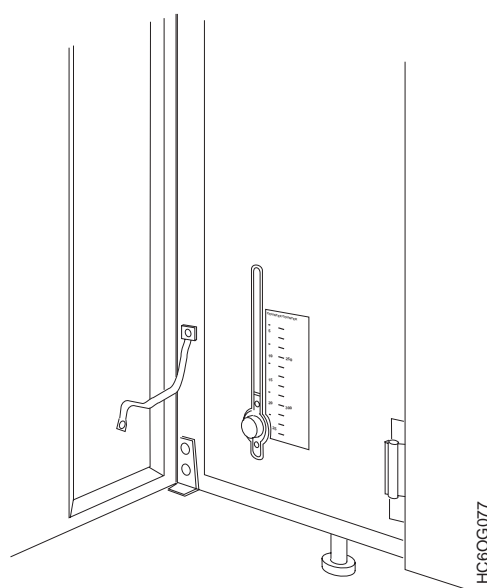

Figure 24. Stacker Height Control

To adjust the output stack height, do the following:

1. Remove any output on the stacker table.
2. Open the front left cover.
3. Loosen the knob by turning it *counterclockwise*.
4. Raise or lower the knob to the desired stack height.
5. Tighten the knob by turning it *clockwise*.
6. Close the front left cover.

---

## Preprocessing and Postprocessing Instructions

The printers have three interface ports. These ports may be equipped with pre/postprocessor (Pre/Post) or Advanced Function postprocessing (AF Post) device interface adaptors as shown in the following table.

Port 1 comes with a Pre/Post device interface adaptor standard. The following table assumes that adaptor is installed.

Table 11. Pre/Postprocessor Interface Options

Port	Configuration Options					
1	Pre/Post	Pre/Post	Pre/Post	Pre/Post	Pre/Post	Pre/Post
2	—	Pre/Post	Pre/Post	AF Post	Pre/Post	AF Post
3 <sup>1</sup>	—	—	Pre/Post	—	AF Post	Pre/Post

<sup>1</sup> Port 3 is not available on Model ED2.

See “Configuring Preprocessing/Postprocessing Devices/Interfaces” on page 241 for details on configuring devices that are being attached to the device interface adaptors that reside in the three ports in the printer.

### Powering On and Off Pre/Post Devices

The following procedures may be necessary for the protection of the operator and the equipment.

The printers recognize electronically attached devices only if those devices are powered-on.

**Attention!**

To avoid damage to the printer stacker table, switch power on to any postprocessing device before you switch power on to the printer to which it is attached. For the same reason, switch power off to the postprocessing device last.

If a preprocessing or postprocessing device stops before the printer becomes Ready, the printer cannot detect that the device is stopped. A forms jam results when printing begins.

### Enabling/Disabling Pre/Post Interfaces

The service representative configures attached preprocessing and postprocessing devices at time of their installation and sets the state of each device to Enabled or Disabled. As configurations change from time to time, you may have to change the preprocessing/postprocessing device interface configurations and to enable or disable the devices. Make these changes from the Display Touch Screen windows.

If a burster/trimmer/stacker (BTS) or an offsetter postprocessing device is to have its enabled status changed, you must make configuration changes in both the **Configure Printer** procedure (see “Configuring the Printer” on page 219) and in the **Configure Pre/Postprocessor** procedure (see “Configuring Preprocessing/Postprocessing Devices/Interfaces” on page 241).

For all other types of postprocessing devices and for all preprocessing devices, you have to make enabled status changes in only the **Configure Pre/Post** procedure.

## Using the Printer Stacker

If a postprocessing device is disabled or not yet configured, you may continue to use boxed forms and the printer stacker. If the postprocessing device includes any rollers, sensors, or any other hardware that would interfere with the operation of the stacker, you must remove those interferences before you attempt to use the stacker.

If the “Stacker Enabled” configuration item under the **Configure Printer** procedure is set to **Yes** and there are no postprocessing devices installed and enabled on the printer, the stacker table automatically rises when printing begins. To raise the stacker table manually, press the stacker table **UP** key on the stacker control panel.

If a postprocessing device is installed on a printer and is enabled, the stacker table is lowered and is prevented from moving upward. The pendulum and other devices in the stacker are also prevented from operating.

In duplex mode, the stacker in Printer 1 is always disabled as if a postprocessing device were installed and enabled.

## Error and Jam Recovery

If the “Jam Recovery Type” configuration item setting under **Configure Printer** allows it, printed pages before the top of the stacker are automatically reprinted following the clearing of a forms jam. This applies only to jams that occur within the printer. If a jam occurs anywhere past the printer stacker (that is, in the postprocessing device), you can extend the number of pages automatically reprinted by setting the “Jam Recovery Point” configuration item under the **Configure Printer** procedure. See “Recovering from a Forms Jam (Simplex Operations)” on page 121 and “Recovering from a Forms Jam (Duplex Operations)” on page 127 for details of recovery from postprocessing device forms jams. Following a forms jam, if a postprocessing device is particularly difficult to thread, you should look for ways of splicing forms together between the printer and the postprocessing device. For jam recovery in a postprocessing device, see “Recovering from a Forms Jam in the Postprocessing Device” on page 135.

## Adding Supplies

The printers normally display “Out of Supplies” messages when an internal usage counter reaches a fixed threshold. You can defer taking action on most “Out of Supplies” messages for some amount of additional usage. During that additional usage time, the “Out of Supplies” message reappears each time an error condition is detected or an end-of-forms is detected. When you use a roll-feed preprocessing device, the printer checks the level of the supplies every 4000 feet after an initial deferred “Out of Supplies” message was presented. The printer also displays an “Out of Supplies” message at that time, if no end-of-forms or error condition is detected.

## Nonprocess Runout (NPRO)

The Nonprocess Runout (NPRO) function lets you move forms from the transfer station to the stacker. To add an extended length to the standard NPRO length (for example, if you use a postprocessing device), you can do the following:

- Increase the “NPRO Length” configuration item under the **Configure Printer** procedure. See “Configuring the Printer” on page 219 and “NPRO Length” on page 223 for more information.
- Increase an enabled preprocessing or postprocessing device “Pre/postprocessor Extended NPRO” characteristics item under the **Configure Pre/Post** procedure. See “Configuring Preprocessing/Postprocessing Devices/Interfaces” on page 241 and “Extended NPRO” on page 243 for more information.

See “Advancing Forms Using the NPRO and NPRO Page Functions” on page 75 for detailed information and instructions about NPRO and NPRO Page.



## Recovering from a Forms Jam (Simplex Operations)

This section describes how to clear specific simplex mode form jams. All of the messages that appear and function switches you need to use are on the Display Touch Screen windows.

See “Recovering from a Forms Jam (Duplex Operations)” on page 127 for details of jam recovery when operating the system printers in duplex printing mode.

Depending on how they are configured, the printers can automatically reprint certain pages as part of the recovery process after some jams.

You must set the following **Configure Printer** configuration items to allow automatic reprinting following a forms jam recovery:

- **Jam Recovery Type:** Must be set to one of the following:
  - “Use Normal Jam Repositioning”
  - “Suppress MICR Jam Repositioning”, and MICR postprocessing printing is not being requested.
- **Direct Attach:** Must be set to “No”.

Automatic reprinting normally requests from the host and reprints the number of pages of data, based on the current in-effect page length, for all the pages that can fit in the forms path between the transfer station and the top of the stacker at the time the jam was detected. Also, if a postprocessing device is used, an extra number of pages can be added to the normal number of reprinted pages by setting the **Jam Recovery Point Distance** configuration item under the **Configure Printer** procedure to a non-zero value. This extra number of pages is the physically configured distance from the top of the stacker to or through the postprocessing device. Figure 25 shows the normal reprint path length from the transfer station (1) to the stacker (3). It also shows the additional Jam Recovery Point Distance from the stacker (3) to or through the postprocessing device (5).

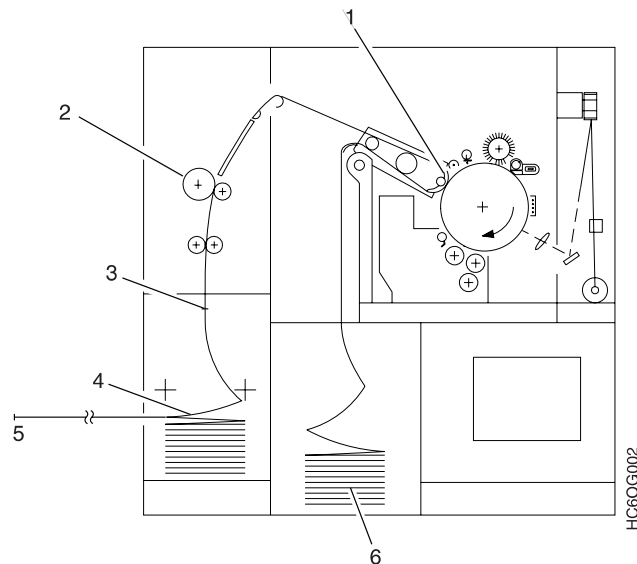

Figure 25. Reprint Path Length

Following the automatic reprinting of pages, you must check for and discard any duplicate pages that may have been printed. Locate the first reprinted page, and

attempt to find that same page in the stacker or a postprocessing device. If you find it, discard all pages starting with that page.

In all cases but one, the automatic reprinting of pages recovers all pages that might have been lost or damaged as the result of the jam. The exception occurs when a FUSER WRAP 0134 jam type is detected. A jam of this type can backup (accordion-pleat) the forms until the error is detected and the forward movement of the forms stopped. If this occurs, a few lost pages are not automatically reprinted. You need to work with the host system console operator to take action to recover those lost pages.

If the printer is not configured to recover lost pages, you may need to ask the host system console operator to do one of the following:

- Restart the job at the point where the output was lost
- Restart the entire job.

## Jams Within the Printer Engine

Do this task when a **Printer Error** Display Touch Screen window shows one of the messages that are listed in Table 12 on page 123. All of the messages apply to all printer models unless otherwise noted.

**Important**

To clear the jam message from the Display Touch Screen window, do the following:

- For STACKER JAM 161 and STACKER JAM 164, you must open and close the stacker gate, *or* you must lower and raise the stacker table.
- For the jam messages in the following list, **SELECT** the **Check Reset** pushbutton on the Display Touch Screen.

UPPER TRACTOR FORMS JAM 0119

TENSION ARM DOWN 0131

TENSION ARM UP 0132

SKEW ERROR 0133

FUSER WRAP 0134

## Jam Recovery Procedures

Table 12. Jam Recovery Procedures - Simplex Mode

Error Message SRC Code (In Numeric Order)	Recovery Actions
UPPER TRACTOR FORMS JAM 0119 TENSION ARM DOWN 0131 TENSION ARM UP 0132 SKEW ERROR 0133 FUSER WRAP 0134  <b>(Forms are jammed, torn, or separated.)</b>	<ol style="list-style-type: none"> <li>1. Clear the forms path. See “Clearing the Forms Path” on page 136.</li> <li>2. If any of the <b>Printer Error</b> messages still appear, <b>SELECT</b> the <b>Check Reset</b> pushbutton on the <b>Printer Error</b> Display Touch Screen window.</li> <li>3. Check for and resolve or postpone any other error or intervention message appearing on the Display Touch Screen windows.</li> <li>4. Reload the forms. See “Loading Forms (Simplex or Dual Simplex Mode)” on page 102.</li> <li>5. <b>SELECT</b> the <b>Ready</b> pushbutton on the Display Touch Screen window for the affected printer.</li> <li>6. If reprinting is allowed, all unfused pages between the transfer station and the top of the stacker plus any jam recovery point distance defined in the printer configuration are reprinted. Check for and discard duplicate pages.  If the jam was the result of a FUSER WRAP 0134, all lost or damaged pages may not be reprinted. Work with the host system console operator to recover these pages.</li> <li>7. If reprinting is not allowed, work with the host system console operator to recover the lost pages.</li> <li>8. See “Suggestions for Preventing Jams” on page 144 if the error recurs frequently.</li> </ol>

Table 12. Jam Recovery Procedures - Simplex Mode (continued)

Error Message SRC Code (In Numeric Order)	Recovery Actions
<p>UPPER TRACTOR FORMS JAM 0119  TENSION ARM DOWN 0131  TENSION ARM UP 0132  SKEW ERROR 0133  FUSER WRAP 0134</p> <p><b>(Forms are <u>NOT</u> jammed, torn, or separated.)</b></p>	<ol style="list-style-type: none"> <li>1. If you do not find a forms jam, do the following: <ol style="list-style-type: none"> <li>a. Be aware that dark-colored backing on the forms can cause the printer to display these messages.</li> <li>b. The message UPPER TRACTOR FORMS JAM 0119 may appear if the printer engine top cover is open and allowing light to affect an optical sensor. Ensure that the top cover is closed.</li> <li>c. Clean the upper tractor jam sensor. See step 16 on page 93.</li> </ol> </li> <li>2. Open the upper tractor covers and ensure that the tractor holes align with the tractor pins.</li> <li>3. Hold down the tension arm while you do the following: <ol style="list-style-type: none"> <li>a. Use the <b>Forms Feed</b> switches on the printer control panel to align the form perforation of the first full page with the correct length alignment mark on the rear tractor cover. See Figure 27 on page 130 for details.</li> <li>b. <b>SELECT</b> the <b>Table Up</b> pushbutton on the stacker control panel to make the forms taut.</li> </ol> </li> <li>4. If any of the <b>Printer Error</b> messages are still displayed, <b>SELECT</b> the <b>Check Reset</b> pushbutton on the <b>Printer Error</b> Display Touch Screen window.</li> <li>5. Check for and resolve or postpone any other error or intervention message appearing on the Display Touch Screen windows.</li> <li>6. Check to ensure that the perforation is aligned at the correct forms length of the tractor station alignment scale and adjust if necessary.</li> <li>7. <b>SELECT</b> the <b>Ready</b> pushbutton on the Display Touch Screen window.</li> <li>8. If reprinting is allowed, all unfused pages between the transfer station and the top of the stacker plus any jam recovery point distance defined in the printer configuration are reprinted. Check for and discard duplicate pages.</li> <li>9. If reprinting is not allowed, work with the host system console operator to recover the lost pages.</li> <li>10. See "Suggestions for Preventing Jams" on page 144 if the error recurs frequently.</li> </ol>

Table 12. Jam Recovery Procedures - Simplex Mode (continued)

Error Message SRC Code (In Numeric Order)	Recovery Actions
<p>STACKER FORMS JAM 0161 STACKER FORMS JAM 0164</p> <p><b>(These errors are not set when a Postprocessing Device Interface feature is installed and enabled, which disables the stacker mechanism.)</b></p>	<ol style="list-style-type: none"> <li>1. Visually check to see if a forms jam is actually present.</li> <li>2. Open the stacker gate.</li> <li>3. If you do not find a jam, clean the stacker jam sensors. See step 30 on page 98 under “Cleaning the Printer.” Go to step 5.</li> <li>4. If you find a jam, clear forms from the “Stacker and Pendulum Area” on page 143. <i>Note: When you remove the forms from the stacker, leave 4 to 5 pages attached to the end of the job running in the stacker to ensure correct forms folding when printing resumes.</i></li> <li>5. Close the stacker gate.</li> <li>6. If either <b>Printer Error</b> stacker jam message is still displayed, <b>SELECT</b> the <b>Check Reset</b> pushbutton on the <b>Printer Error</b> Display Touch Screen window.</li> <li>7. Check for and resolve or postpone any other error or intervention message appearing on the Display Touch Screen window.</li> <li>8. Ensure that the <b>Forms Set</b> indicator on the printer control panel displays the same fold direction as the first fold below the perforations on the forms guide.</li> <li>9. <b>SELECT</b> the <b>Ready</b> pushbutton on the Display Touch Screen window for the affected printer.</li> <li>10. If reprinting is allowed, all unfused pages between the transfer station and the top of the stacker plus any jam recovery point distance defined in the printer configuration are reprinted. Check for and discard duplicate pages.</li> <li>11. If reprinting is not allowed, work with the host system console operator to recover the lost pages.</li> <li>12. See “Suggestions for Preventing Jams” on page 144 if the error recurs frequently.</li> </ol>

## Jams Between the Printer and a Postprocessing Device

Jams or separated forms that occur between the printer and the postprocessing device are not detected and presented as form jams. The usual error condition presented is a Pre/postprocessor NOT READY line became active D204 message. This error message occurs when the “Pre/postprocessor Busy Timer” (see “Configuring Preprocessing/Postprocessing Devices/Interfaces” on page 241 for details) has timed out.

1. Clear the forms path of any jam, or clear any forms-feeding problem between the postprocessing device and the printer.
2. **SELECT** the **Check Reset** pushbutton on the **Printer Error** Display Touch Screen window.
3. Make the postprocessing device Ready.
4. If you have to remove damaged or separated forms in the forms path, you must rethread the postprocessing device.
5. **SELECT** the **Ready** pushbutton on the Display Touch Screen for the affected printer.
6. If you want to reprint pages, **SELECT** the **Jam Recovery** pushbutton on the **Intervention Required** window.
7. **SELECT** the **Completed** pushbutton on the **Intervention Required** window. (You do not have to wait between **SELECTING** the **Jam Recovery** and **Completed** pushbuttons.)
8. **SELECT** the **Ready** pushbutton on the Display Touch Screen.

For jams in a postprocessing device, see “Recovering from a Forms Jam in the Postprocessing Device” on page 135.

---

## Recovering from a Forms Jam (Duplex Operations)

This section contains techniques for clearing specific form jams that appear as error messages on the **Printer Error** window on the Display Touch Screen when the printer is operating in duplex printing mode.

All the messages that appear and some function switches you need to use are on the Display Touch Screen windows.

**Note:** When a function switch is on the Display Touch Screen window, only the printer switch, which is called a pushbutton, is described in this section. When a function switch is available only on the Display Touch Screen windows, it is the only function switch, called a pushbutton, described.

See “Recovering from a Forms Jam (Simplex Operations)” on page 121 for details of jam recovery when the system printers are in simplex printing mode. After some jams occur within the printer engine, the printer automatically reprints certain pages as part of its recovery process. This occurs only if the printer is configured to allow reprinting.

You must set the following **Configure Printer** configuration items to allow automatic reprinting following a forms jam recovery:

- **Jam Recovery Type:** Must be set to one of the following:
  - “Use Normal Jam Repositioning”
  - “Suppress MICR Jam Repositioning”, and MICR postprocessing printing is not being requested
- **Direct Attach:** Must be set to “No”.

Automatic reprinting normally requests and reprints the number of pages of data, based on the current in-effect page length, for all of the pages that can fit in the forms path between the transfer station in Printer 1 and the top of the stacker in Printer 2 at the time the jam was detected. Also, if a postprocessing device is used, an extra number of pages can be added to the normal number of reprinted pages. Do this by setting the **Jam Recovery Point Distance** configuration item under the **Configure Printer** procedure to a non-zero value. This extra number of pages is the physically configured distance from the top of the stacker in Printer 2 to or through the postprocessing device. Figure 26 shows the normal reprint path length from the transfer station (3) in Printer 1 to the stacker in Printer 2 (7). It also shows the additional Jam Recovery Point Distance from the stacker in Printer 2 (7) to or through the postprocessing device (6).

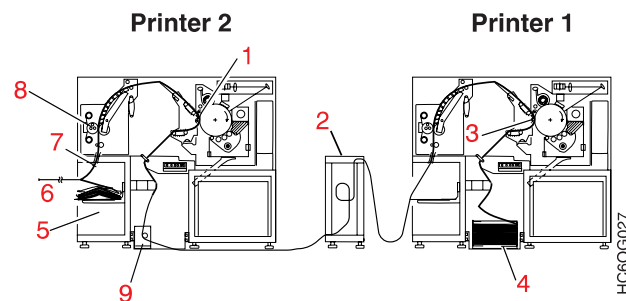

Figure 26. Duplex Mode Reprint Path Length

Following the automatic reprinting of pages, you must check for and discard any duplicate pages that may have been printed. Locate the first reprinted page, then find that same page in the stacker or a postprocessing device. Discard all pages starting with that page.

In all cases but one, the automatic reprinting of pages recovers all pages that might have been lost or damaged as the result of the jam. The exception occurs when a FUSER WRAP 0134 jam type is detected. A jam of this type can backup (accordion-pleat) the forms until the error is detected and the forward movement of the forms stopped. If this occurs, there are some small number of lost pages that are not automatically reprinted. You need to work with the host system console operator to take action to recover those lost pages.

Also, if automatic reprinting is not allowed, you need to work with the host system console operator to recover lost pages by one of the following actions:

- Restart the job at the point where the output was lost
- Restart the entire job.

Similar to recovering from a forms jam in simplex mode, you must rethread the printer with the jam. However, in addition to rethreading the printer with the jam, you may also have to rethread the other printer (if the jam occurred in Printer 1). Whenever rethreading is required, the **Thread/Align Forms** Display Touch Screen procedure window automatically appears and requires you to execute and complete that procedure (see “Thread/Align Forms” on page 152).

**Important**

To clear the jam message from the Display Touch Screen window, the printer logic requires the following:

- For STACKER JAM 161 and STACKER JAM 164, open and close the stacker gate, *or* you must lower and then raise the stacker table.
- Press the **Check Reset** pushbutton on the Display Touch Screen.



# Jams Within Printer 1

Do this task when the **Printer Error** Display Touch Screen window shows one of the messages that is listed in Table 13:

Table 13. Printer 1 Jam Recovery Procedures - Duplex Mode

Error Message SRC Code (In Numeric Order)	Recovery Actions
UPPER TRACTOR FORMS JAM 0119 TENSION ARM DOWN 0131 TENSION ARM UP 0132 SKEW ERROR 0133 FUSER WRAP 0134  <b>(Forms are jammed, torn, or separated.)</b>	<ol style="list-style-type: none"> <li>1. Clear the forms path. See “Clearing the Forms Path” on page 136.</li> <li>2. If any of the <b>Printer Error</b> messages are still displayed, <b>SELECT</b> the <b>Check Reset</b> pushbutton on the <b>Printer Error</b> Display Touch Screen window.</li> <li>3. Check for and resolve or postpone any other error or intervention message appearing on the Display Touch Screen windows.</li> <li>4. Reload the forms. See “Loading Forms (Duplex Mode)” on page 115.</li> <li>5. Enter the <b>Thread/Align Forms</b> procedure (see “Forms Are Broken Between the Printers” on page 162).               <ol style="list-style-type: none"> <li>a. <b>SELECT</b> the <b>Feed Forms</b> pushbutton once; this provides enough forms beyond Printer 1 to splice the forms (on the floor between Printer 1 and Printer 2) just loaded on Printer 1 to the forms remaining in the path.</li> <li>b. Complete the <b>Thread/Align Forms</b> procedure.</li> <li>c. Do all the steps in “Checking the Forms Alignment” on page 84 for both Printer 1 and Printer 2.</li> </ol> </li> <li>6. <b>SELECT</b> the <b>Ready</b> pushbutton on the Display Touch Screen window for the affected printer.</li> <li>7. If reprinting is allowed, all unfused pages between the transfer station in Printer 1 and the top of the stacker plus any jam recovery point distance defined in the printer configuration in Printer 2 are reprinted. Check for and discard duplicate pages.</li> <li>8. If reprinting is not allowed, work with the host system console operator to recover the lost pages.</li> <li>9. See “Suggestions for Preventing Jams” on page 144 if the error recurs frequently.</li> </ol>

Table 13. Printer 1 Jam Recovery Procedures - Duplex Mode (continued)

Error Message SRC Code (In Numeric Order)	Recovery Actions
<p>UPPER TRACTOR FORMS JAM 0119  TENSION ARM DOWN 0131  TENSION ARM UP 0132  SKEW ERROR 0133  FUSER WRAP 0134</p> <p><b>(Forms are <u>NOT</u> jammed, torn, or separated.)</b></p>	<ol style="list-style-type: none"> <li>1. If you do not find a forms jam, do the following: <ol style="list-style-type: none"> <li>a. Be aware that dark-colored backing on the forms can cause the printer to display these messages.</li> <li>b. The message UPPER TRACTOR FORMS JAM 0119 may appear if the printer engine top cover is open and allowing light to affect an optical sensor. Ensure that the top cover is closed.</li> <li>c. Clean the upper tractor jam sensor. See step 16 on page 93.</li> </ol> </li> <li>2. Open the upper tractor covers and ensure that the tractor holes align with the tractor pins.</li> <li>3. Check to ensure that the perforation on both Printer 1 and Printer 2 are aligned at the correct forms length of the rear tractor alignment scale; adjust if necessary. See Figure 27 for details.</li> <li>4. If any of the <b>Printer Error</b> messages are still displayed, <b>SELECT</b> the <b>Check Reset</b> pushbutton on the Display Touch Screen window.</li> <li>5. Check for and resolve or postpone any other error or intervention message appearing on the Display Touch Screen windows.</li> <li>6. If necessary, enter the <b>Thread/Align Forms</b> procedure (see “Forms Are Loaded Through Both Printers” on page 154).</li> <li>7. Complete the <b>Thread/Align Forms</b> procedure.</li> <li>8. <b>SELECT</b> the <b>Ready</b> pushbutton on the Display Touch Screen window.</li> <li>9. If reprinting is allowed, all unfused pages between the transfer station in Printer 1 and the top of the stacker plus any jam recovery point distance defined in the printer configuration in Printer 2 are reprinted. Check for and discard duplicate pages.</li> <li>10. If reprinting is not allowed, work with the host system console operator to recover the lost pages.</li> <li>11. See “Suggestions for Preventing Jams” on page 144 if the error recurs frequently.</li> </ol>

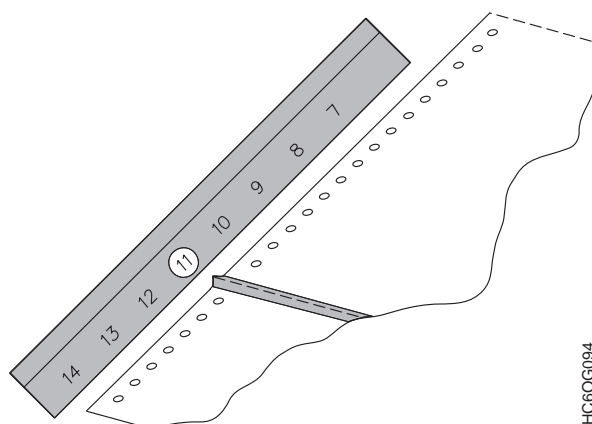

Figure 27. Reestablishing Forms Alignment

HC6OG094

## Jams Within Printer 2

Do this task when the **Printer Error** Display Touch Screen window shows one of the messages that is listed in Table 14:

Table 14. Printer 2 Jam Recovery Procedures - Duplex Mode

Error Message SRC Code (In Numeric Order)	Recovery Actions
<p>UPPER TRACTOR FORMS JAM 0119            TENSION ARM DOWN 0131            TENSION ARM UP 0132            SKEW ERROR 0133            FUSER WRAP 0134</p> <p><b>(Forms are jammed, torn, or separated.)</b></p>	<ol style="list-style-type: none"> <li>1. Clear the forms path. See “Clearing the Forms Path” on page 136.</li> <li>2. If any of the <b>Printer Error</b> messages are still displayed, <b>SELECT</b> the <b>Check Reset</b> pushbutton on the <b>Display Touch Screen</b> window.</li> <li>3. Check for and resolve or postpone any other error or intervention message appearing on the Display Touch Screen windows.</li> <li>4. If necessary, enter the <b>Thread/Align Forms</b> procedure (see “Forms Are Broken Between the Printers” on page 162).               <ol style="list-style-type: none"> <li>a. <b>SELECT</b> the <b>Feed Forms</b> pushbutton twice; this provides enough forms beyond Printer 1 to load Printer 2.</li> <li>b. Complete the <b>Thread/Align Forms</b> procedure by adding enough forms beyond Printer 2 to splice (on the floor between Printer 2 and a postprocessing device) forms just loaded on Printer 2 to the forms remaining threaded in a postprocessing device.</li> <li>c. Do all the steps in “Checking the Forms Alignment” on page 84 for both Printer 1 and Printer 2.</li> </ol> </li> <li>5. <b>SELECT</b> the <b>Ready</b> pushbutton on the Display Touch Screen window.</li> <li>6. If reprinting is allowed, all unfused pages between the Transfer Station in Printer 1 and the top of the Stacker in Printer 2 are reprinted. Check for and discard duplicate pages.                If the jam was the result of a FUSER WRAP 0134 in printer 2, all lost or damaged pages may not be reprinted. Work with the host system console operator to recover these pages.</li> <li>7. If reprinting is not allowed, work with the host system console operator to recover the lost pages.</li> <li>8. See “Suggestions for Preventing Jams” on page 144 if the error recurs frequently.</li> </ol>

Table 14. Printer 2 Jam Recovery Procedures - Duplex Mode (continued)

Error Message SRC Code (In Numeric Order)	Recovery Actions
<p>UPPER TRACTOR FORMS JAM 0119  TENSION ARM DOWN 0131  TENSION ARM UP 0132  SKEW ERROR 0133  FUSER WRAP 0134</p> <p><b>(Forms are <u>NOT</u> jammed, torn, or separated.)</b></p>	<ol style="list-style-type: none"> <li>1. If you do not find a forms jam, do the following: <ol style="list-style-type: none"> <li>a. Be aware that dark-colored backing on the forms can cause the printer to display these messages.</li> <li>b. The message UPPER TRACTOR FORMS JAM 0119 may appear if the printer engine top cover is open and allowing light to affect an optical sensor. Ensure that the top cover is closed.</li> <li>c. Clean the upper tractor jam sensor. See step 16 on page 93.</li> </ol> </li> <li>2. Open the upper tractor covers and ensure that the tractor holes align with the tractor pins.</li> <li>3. Check to ensure that the perforation on both Printer 1 and Printer 2 are aligned at the correct forms length of the tractor station alignment scale and adjust if necessary. See Figure 27 on page 130 for details.</li> <li>4. If there is no post processing device attached to Printer 2, press the <b>Table Up</b> key on the Printer 2 stacker control panel to make the forms taut.</li> <li>5. If any of the <b>Printer Error</b> messages are still displayed, <b>SELECT</b> the <b>Check Reset</b> pushbutton on the <b>Printer Error</b> Display Touch Screen window.</li> <li>6. Check for and resolve or postpone any other error or intervention message appearing on the Display Touch Screen windows.</li> <li>7. If necessary, enter the <b>Thread/Align Forms</b> procedure (see “Forms Are Loaded Through Both Printers” on page 154).</li> <li>8. Complete the <b>Thread/Align Forms</b> procedure.</li> <li>9. <b>SELECT</b> the <b>Ready</b> pushbutton on the Display Touch Screen window.</li> <li>10. If reprinting is allowed, all unfused pages between the Transfer Station in Printer 1 and the top of the Stacker in Printer 2 are reprinted. Check for and discard duplicate pages.</li> <li>11. If reprinting is not allowed, work with the host system console operator to recover the lost pages.</li> <li>12. See “Suggestions for Preventing Jams” on page 144 if the error recurs frequently.</li> </ol>

Table 14. Printer 2 Jam Recovery Procedures - Duplex Mode (continued)

Error Message SRC Code (In Numeric Order)	Recovery Actions
<p>STACKER FORMS JAM 0161            STACKER FORMS JAM 0164</p> <p><b>(These errors are not set when a postprocessing device is installed and enabled, which disables the stacker mechanism.)</b></p>	<ol style="list-style-type: none"> <li>1. Visually check to see if a forms jam is actually present.</li> <li>2. Open the stacker gate.</li> <li>3. If you do not find a jam, clean the stacker jam sensors. See step 30 on page 98 under “Cleaning the Printer.” Go to step 5.</li> <li>4. If you do find a jam, clear forms from the “Stacker and Pendulum Area” on page 143. <b>Note: When you remove the forms from the stacker, leave 4 to 5 pages attached to the end of the job running in the stacker to ensure correct forms folding when printing resumes.</b></li> <li>5. Close the stacker gate.</li> <li>6. If either stacker jam message is still displayed, <b>SELECT</b> the <b>Check Reset</b> pushbutton on the <b>Printer Error</b> Display Touch Screen window.</li> <li>7. Check for and resolve or postpone any other error or intervention message appearing on the Display Touch Screen window.</li> <li>8. Ensure that the <b>Forms Set</b> indicator on the printer control panel displays the same fold direction as the fold on the lower tractors.</li> <li>9. If necessary, enter the <b>Thread/Align Forms</b> procedure (see “Forms Are Broken Between the Printers” on page 162).             <ol style="list-style-type: none"> <li>a. <b>SELECT</b> the <b>Feed Forms</b> pushbutton twice; this provides enough forms beyond Printer 1 to load Printer 2.</li> <li>b. Complete the <b>Thread/Align Forms</b> procedure by adding enough forms beyond Printer 2 to splice (on the floor between Printer 2 and a postprocessing device) forms just loaded on Printer 2 to the forms remaining threaded in a postprocessing device.</li> <li>c. Do all the steps in “Checking the Forms Alignment” on page 84 on both Printer 1 and Printer 2.</li> </ol> </li> <li>10. <b>SELECT</b> the <b>Ready</b> pushbutton on the Display Touch Screen window for the affected printer. Even if automatic reprinting is allowed, no pages are reprinted for this type of jam.</li> <li>11. See “Suggestions for Preventing Jams” on page 144 if the error recurs frequently.</li> </ol>

## Jam Between Printer 1 and Printer 2

A jam occurring between Printer 1 and Printer 2 normally causes the forms to tear and separate. Both Printer 1 and Printer 2 continue to feed forms and print until an error condition is detected and displayed. A large supply of forms may be present on the floor at the output of Printer 1.

1. **SELECT** the **Check Reset** pushbutton on the **Intervention Required** Display Touch Screen window.
2. Do not flush any forms out of either printer.
3. Manually pull the forms through the Buffer/Flipper Unit, under Printer 2, and up into forms input area of Printer 2.
4. Enter the **Thread/Align Forms** Display Touch Screen procedure (see “Forms Are Broken Between the Printers” on page 162). If necessary, **SELECT** the **Printer 1 Feed Page** pushbutton on the **Thread/Align Forms** window to feed enough forms to splice the forms from the Buffer/Flipper Unit to the forms remaining in the Printer 2 path.
5. Complete the **Thread/Align Forms** procedure.
6. **SELECT** the **Ready** pushbutton on the main Display Touch Screen window.

## Jams Between the Printer and a Postprocessing Device

A jam or separated form occurring between the printer and the postprocessing device is not detected and presented as a form jam. The usual error condition presented is a Pre/postprocessor NOT READY line became active D204 message on a **Printer Error** Display Touch Screen window or a PRINTER ERROR D204 message. This error message occurs when the “Pre/postprocessor Busy Timer” of an installed and enabled postprocessing device has timed out (see “Configuring Preprocessing/Postprocessing Devices/Interfaces” on page 241 for details).

1. Clear the forms path of any jam, or clear any forms feeding problem between the postprocessing device and the printer.
2. **SELECT** the **Check Reset** pushbutton on the **Printer Error** Display Touch Screen window.
3. If you must remove damaged or separated forms in the forms path between the postprocessing device and the printer, advance the forms through the printers enough to splice, on the floor between the printer and the postprocessing device, the forms exiting the printer to the forms remaining in the postprocessing device.
4. Make the postprocessing device Ready.
5. **SELECT** the **Ready** pushbutton on the Display Touch Screen for the affected printer.

## Recovering from a Forms Jam in the Postprocessing Device

When a forms jam occurs in a postprocessing device that causes the device to go to a Not Ready condition, the **Intervention Required** window provides an additional pushbutton, **Jam Recovery**. This pushbutton causes a number of pages to be reprinted. The number of pages that are reprinted is determined by the distance from the printer to the farthest postprocessing device that is attached to the printer.

If a forms jam occurs in the postprocessing device that causes a Not Ready condition, the **Intervention Required** window appears on the Display Touch Screen. The **D204** SRC code appears on the window.

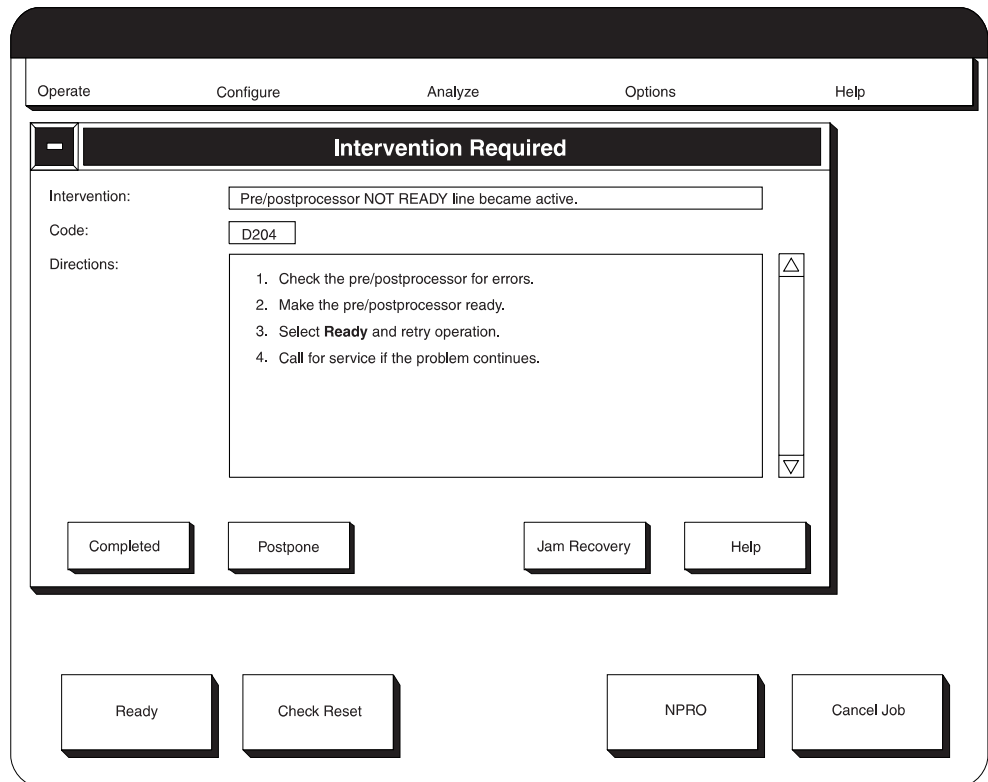

1. Remove the jammed forms from the postprocessing device.
2. If you want to reprint pages, **SELECT** the **Jam Recovery** pushbutton on the **Intervention Required** window.
3. **SELECT** the **Completed** pushbutton on the **Intervention Required** window. (You do not have to wait between **SELECTING** the **Jam Recovery** and **Completed** pushbuttons.)
4. **SELECT** the **Ready** pushbutton on the Display Touch Screen.

---

## Clearing the Forms Path

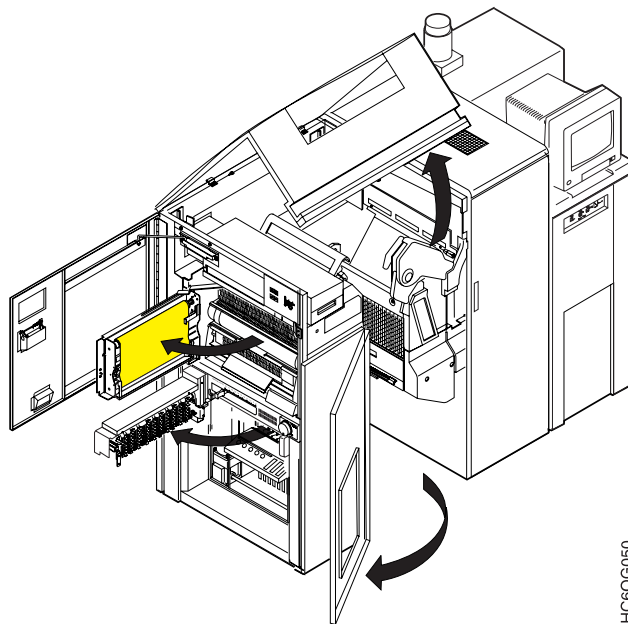

HC6G050

### Transfer Station Area

1. Open the top left and front left center covers.

**Attention!**

Do *not* use the **Forms Feed** pushbutton on the printer Display Touch Screen if forms are jammed in the transfer station.

2. Break the forms at a perforation in the input area below the transfer station.
3. Break the forms at a perforation between the tension arm area and the fuser entry area.



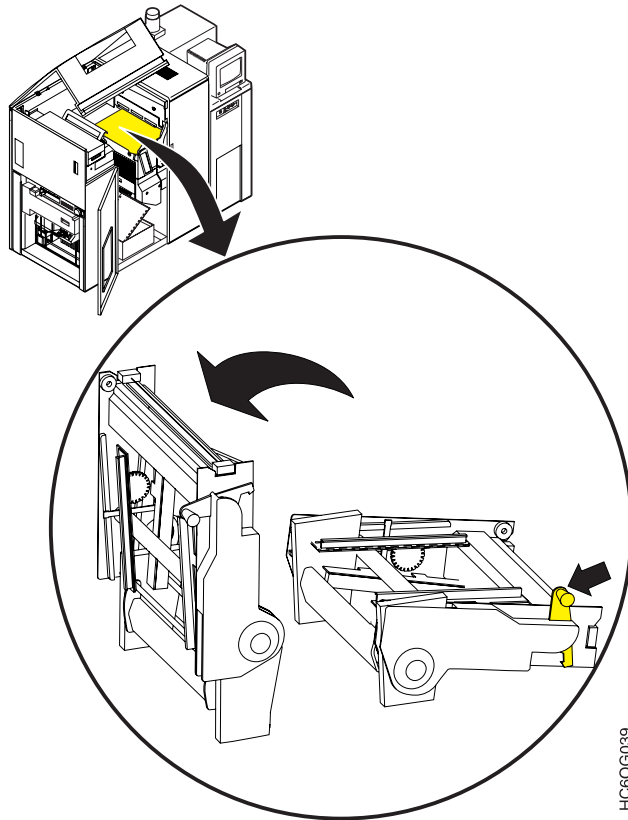

4. Raise the transfer station away from the photoconductor drum.

**Attention!**

The photoconductor drum is easily damaged, and it is *very* expensive to replace.

When the transfer station is open, the photoconductor drum is automatically covered to prevent damage to the drum.



**CAUTION:**

<73> Do not wear jewelry (rings, watches, or bracelets) when working in this area.

CAUT0103

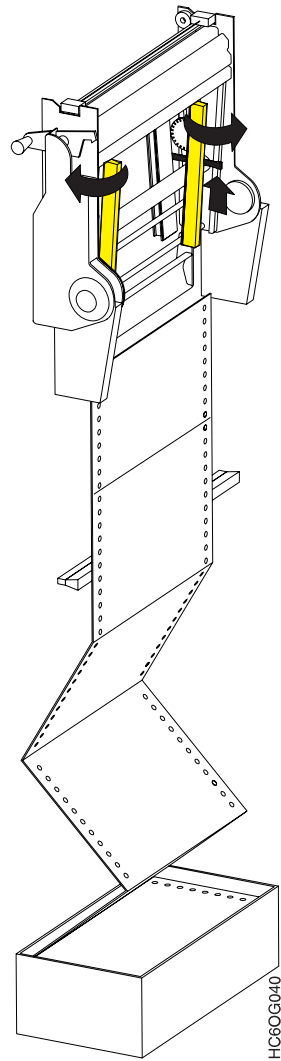

5. Open the lower transfer station tractor covers.
6. Check for torn carrier strips, oversized carrier holes, and torn paper.
7. Remove any torn forms, carrier strips, and paper chads from the lower tractor area.
8. Close the lower tractor covers.
9. Lower the transfer station and latch it securely into position.

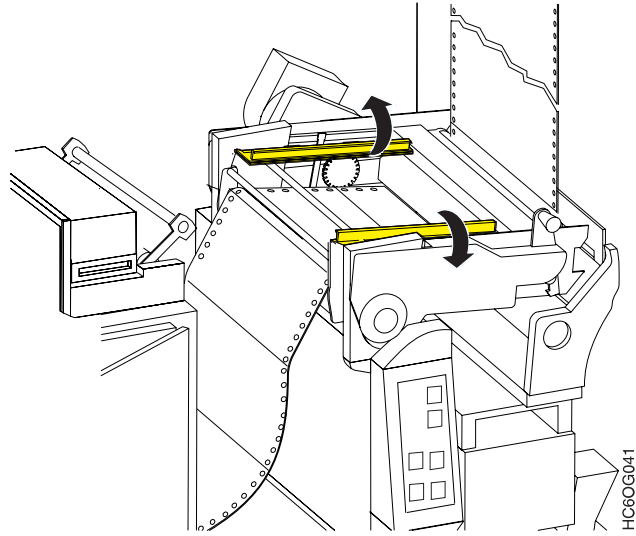

10. Open the upper transfer station tractor covers.
11. Check for torn carrier strips, oversized carrier holes, and torn paper.
12. Remove any torn forms, carrier strips, and paper chads from the transfer station area, the transfer corona, and the retractors.
13. Close the upper tractor covers.
14. Press the **Forms Feed - Forward** pushbutton to clear the forms from the fuser area.

## Fuser and Stacker Areas

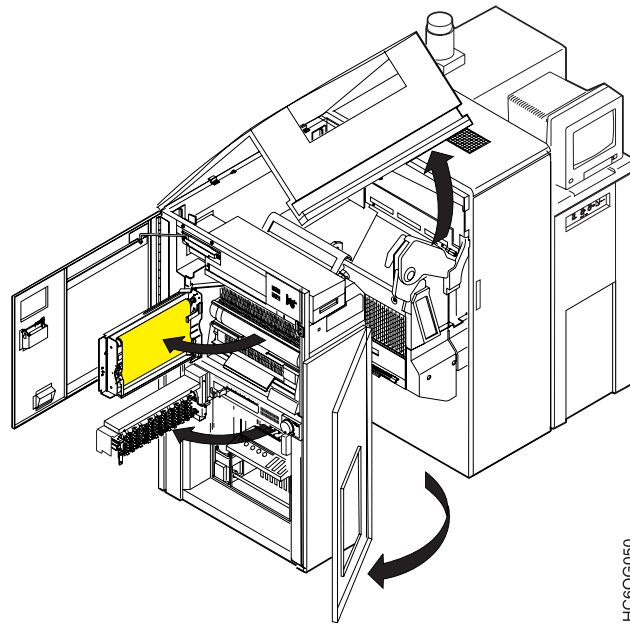

1. Open the top and front left cover and the stacker gate.
2. Break the forms at a perforation near the pendulum.
3. Unload forms from the stacker. See "Unloading the Stacker" on page 169.
4. Close the stacker gate.

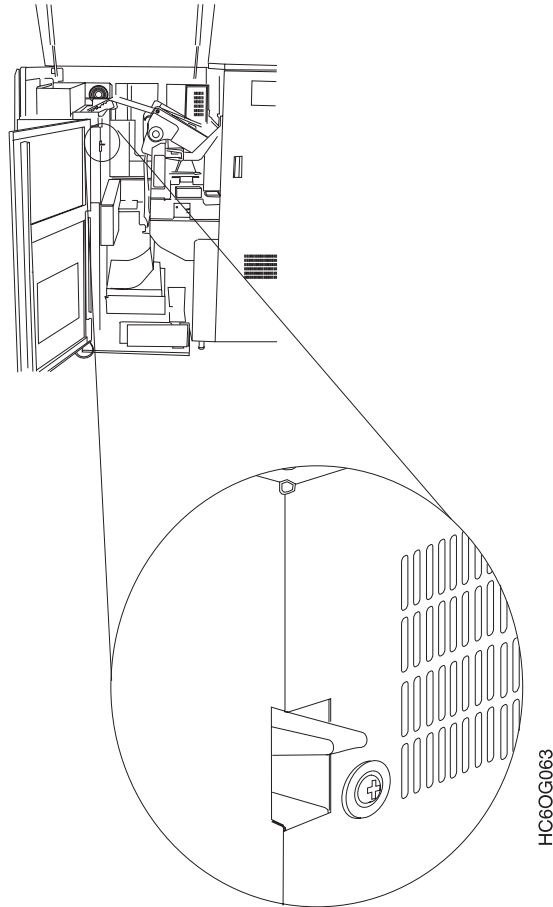

5. Press and hold the puller lever down.
6. Grasping the forms near the fuser entry area, pull them up and out of the fuser. (This moves the forms in the opposite direction from their usual path.)
7. If the forms will not pull up, or if some forms remain in the pendulum, do the following:
  - a. Lower the stacker table.
  - b. Open the stacker gate.
  - c. Grasp both sides of the forms and pull down evenly.
  - d. Close the stacker gate.
  - e. Raise the stacker table.

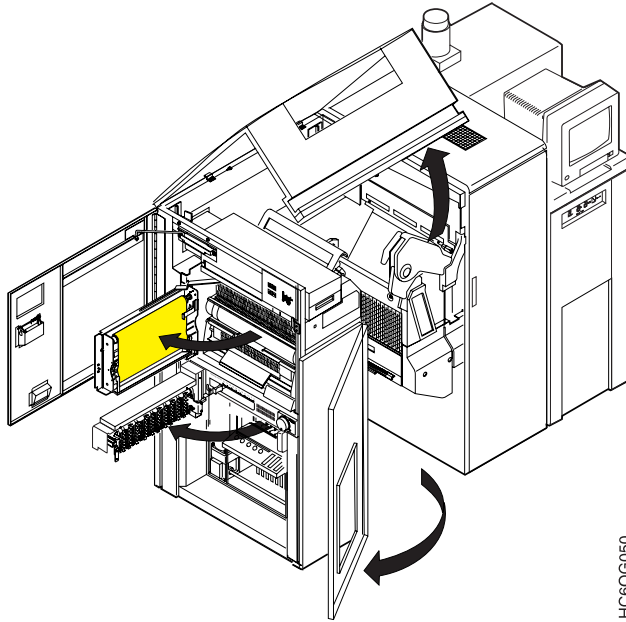

**CAUTION:**

<60> High-temperature. Let parts cool at least 30 minutes in this area before handling.

CAUT0116



**CAUTION:**

<70> The oiler belt, oiler wick roll, and their environments are *high-temperature* areas. Be very careful when working in these areas.

CAUT0100

8. If forms remain in the fuser, do the following:
  - a. Open the oiler-belt gate.
  - b. Lower the hot roll shield.
  - c. Remove any forms you see.
  - d. Raise the hot roll shield.
  - e. Close the oiler-belt gate.
9. Return to the appropriate jam message listed in Table 12 on page 123, Table 13 on page 129, or Table 14 on page 131.

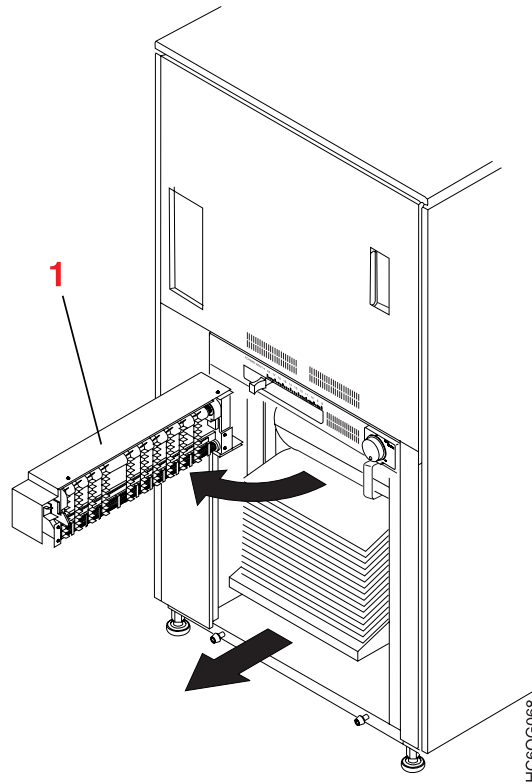

## Stacker and Pendulum Area

1. Open the stacker gate (1).
2. Ensure that the forms are folding correctly; that is, the forms stack lies flat (without bowing between forms).
3. Ensure that the **Forms Set** indicator on the Printer Control Panel is set to match the direction of the first fold perforation that is below the red mark on the forms guide.
4. Separate the forms at the perforation near the top of the stacker. Save as much of the output as possible. Work with the host system console operator to recover any lost pages.
5. Unload forms from the stacker.

**Note:** When you remove the forms from the stacker, leave 4 to 5 pages attached to the end of the job running in the stacker. This ensures that the forms folding is correct when printing resumes. See "Unloading the Stacker" on page 169.

6. Ensure that the correct forms length and width are selected at the Stacker Control Panel.
7. If you receive a message when no forms appear jammed, clean the six stacker jam sensors and two mirrors with a soft dry cloth. See step 30 on page 98 under "Cleaning the Printer."

---

## Suggestions for Preventing Jams

The best way to prevent jams is to use forms and applications that were designed for use with the printers. Form and application problems cannot be corrected by adjusting or repairing the printer.

If a particular form jams frequently, refer the application owner to the *Forms Design Reference for Continuous Forms Advanced Function Printers*. This book contains detailed information about selecting forms and designing applications for use with continuous-forms printers.

It is also important to ensure that the forms are loaded correctly. To prevent jams from happening, do the following:

- Ensure that the forms are not being damaged in one of the following areas:
  - Forms input area
  - Before they reach the transfer corona within the printer engine
  - In the Buffer/Flipper Unit between the printers when they are in duplex mode.
- Ensure that the perforations have ties at the ends, not cuts.
- Ensure that the back sides of the forms do not have dark colors or markings when you use simplex mode. Also ensure that both sides of the forms do not have dark colors or markings when the printers are in duplex mode.
- If you are using fan-fold forms, ensure that the folded or leading edge is not wrinkled or torn.
- If you are using fan-fold forms and the first page is folded under, ensure that the tractor holes line up *exactly*. This is especially important if you are using forms with a  $\frac{1}{3}$ -inch or  $\frac{2}{3}$ -inch length.
- Ensure that the tractor holes are aligned correctly on the tractor pins.
- Ensure that the forms are positioned correctly in the forms input area. The forms must not twist or tear when they travel around the forms guide and through the transfer station.
- If the forms are in a box, ensure that the box does not interfere with form movement.
- If you are using fan-fold forms and the stack of forms seems to curve (dishing), roll the first form in the opposite direction of the curve. Then unroll it before you put the form on the transfer station lower tractors.
- Load different forms, or if you are using fan-fold forms, a new box of the same forms. Ensure that the forms are loaded correctly.
- If the jam occurs only with one kind of form, especially one that has not been used before on the printers, the problem may be form-related. Forms that are unusually heavy or light, forms that have holes or cuts, and adhesive-label forms are all likely to cause jams.

Forms orientation may have an effect on stacking and jam frequency. On non-preprinted forms:

- If you are using fan-fold forms, rotating the box 180° can change the frequency of jams.
- Remove damaged sections.
- If you are using fan-fold forms and you folded back the first page of the form, try loading the form *without* folding. Conversely, if you did *not* fold the form, try doing so.



- If you have been running labels, print a test job on plain paper forms to remove any adhesive residue that the labels may have left in the printer.
- If you are using fan-fold forms, ensure that you leave four to five blank forms correctly folded in the stacker when you resume printing.

---

## Reporting Printer Usage

Each printer has a usage meter:

- **In simplex mode:** The usage meter counts only the feet of forms that are processed while printing takes place.
- **In duplex mode:** The usage meter in each printer counts feet of forms anytime paper is moved through the printers.

The meter advances one position for every 30.48 meters (100 feet) of forms that are processed through the transfer station. The meter reading is used for customer billing.

**Note:** The counts that are shown on these printer usage meters may not match the counts shown in “Printer 1 Counter” and “Printer 2 Counter” areas on the **Printer Status** window on the Display Touch Screen.

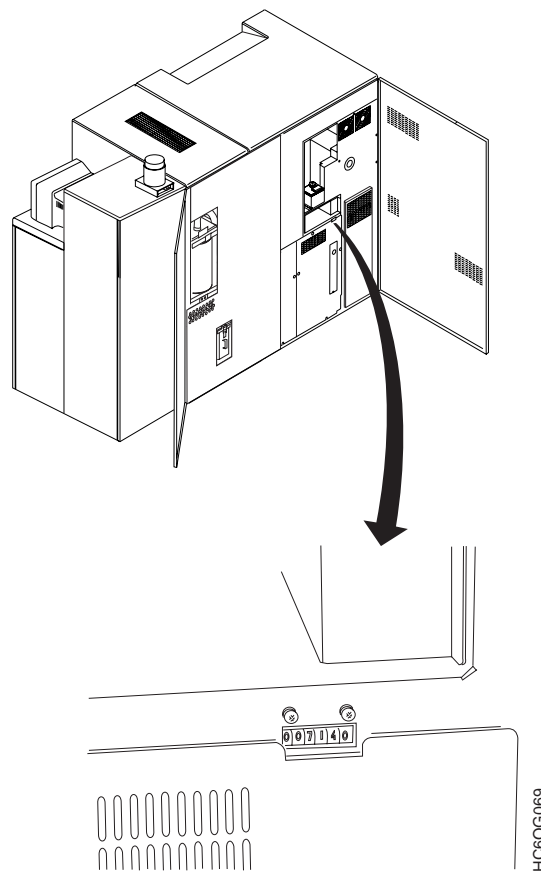

Do this task on the last working day of each month.

You need an IBM Printer Usage Sheet to report printer usage. See Figure 28 on page 147.

 <b>METER READING REMINDER</b>		REFERENCE: PLEASE RETURN BY:		
PLEASE RETURN TO: IBM CORPORATION		ALL INQUIRIES SHOULD BE DIRECTED TO IBM AT:		
TYPE/SERIAL	PRIOR METER READING	METER READING DATE	CURRENT METER READING	REMARKS
SIGNATURE		DATE		
Z125-4383-01				
				R4CO1111

Figure 28. Printer Usage Sheet

A new Printer Usage Sheet is sent to every customer every month.

1. Open the rear right cover.
2. Locate the label **Page Counter X 100**.
3. Write the numbers on the Printer Usage Sheet *exactly* as they appear in the printer usage meter:
  - Right-justify the numbers.
  - Do not add leading or trailing zeros.
  - Write one number in each box.
  - Keep each number inside its box.
  - Use large, simple shapes.
  - Close loops and connect lines.
  - Do not use fancy loops or curls.
4. Fill in the printer serial number, which is on a label below the transfer station at the front of the machine. This label also has the printer model number.
5. Fill in the machine type and the date.
6. Sign the card.
7. Mail the completed sheet to IBM.

## Running Traces

The Traces procedure lets you select, start, stop, and print traces.

### Note

- Trace affects both printers when you are printing in duplex mode. In simplex mode, all trace actions (Start, Stop, Save, and Print) apply to only to that printer.
- Tracing may affect performance.
- The **Configure...** action requires Customer Engineer authorization.

1. **SELECT** the **Analyze** pull-down menu on the main Display Touch Screen window.
2. **SELECT** the **Traces** procedure. The **Traces** window appears with a list of the available traces and the current status of each.

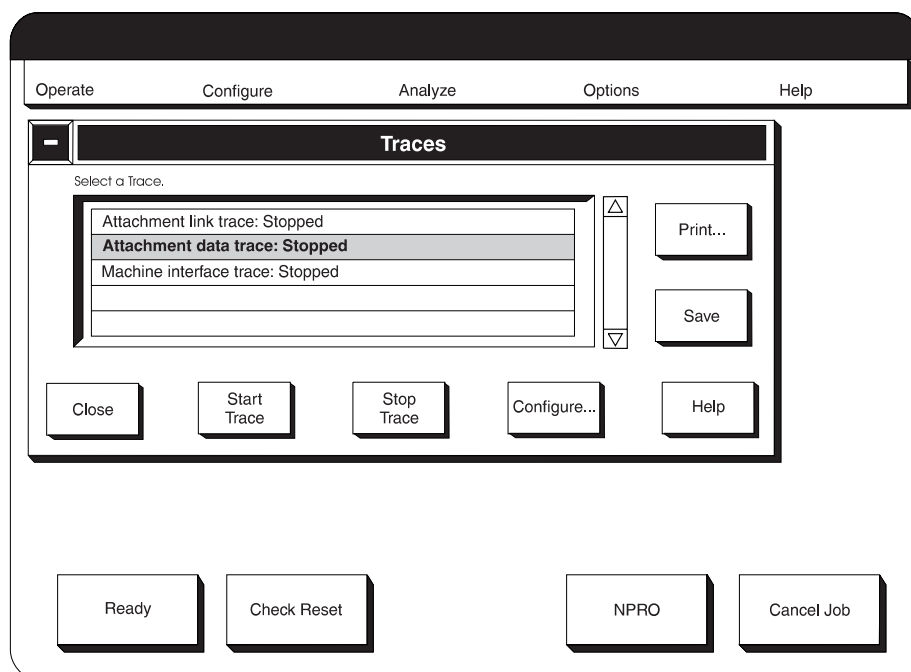

Figure 29. Traces Window

3. To start a trace:
  - a. **SELECT** the trace you want to run from the **Select a Trace** box.
  - b. **SELECT** the **Start Trace** pushbutton.
4. To stop a trace:
  - a. **SELECT** the trace you want to stop from the **Select a Trace** box.
  - b. **SELECT** the **Stop Trace** pushbutton.
5. To save trace data:
  - a. Stop all traces.
  - b. **SELECT** the **Save** pushbutton.
  - c. Insert a diskette in the diskette drive, and **SELECT Save** on the verification window that appears.

6. To print a trace:
  - a. You must stop the trace before you can print it. Do step 4 on page 148.
  - b. Disable all host attachments before you print a trace. See “Enabling and Disabling Attachments” on page 63 for details.
  - c. **SELECT** the **Print...** pushbutton on the **Traces** window. You see the **Print Trace** window.
  - d. **SELECT** the trace you want to print from the **Select a Print File** box.
  - e. To change the number of copies you print, do the following:
    - 1) **SELECT** the **How Many?** field.
    - 2) Type the number of copies you want to print.
    - 3) **SELECT** the **OK** pushbutton.
  - f. **SELECT** the **Print** pushbutton on the **Print Trace** window.

## Adjusting the Preheat Temperature

The **Preheat** selection in Form Characteristics box of the Define Form window allows you to increase the preheat platen temperature to enhance fusing of labels or heavy-stock forms. You increase or decrease the temperature in increments of 5° until optimum fusing is achieved. You should not use the lower temperature settings to print on some synthetic forms, such as vinyl- or latex-impregnated forms.

When you are using regular forms, the temperature should be set to the default value. The default value is set in “Printer Configuration”.

To adjust the preheat platen temperature, do the following:

- **SELECT** the **Configure** pull-down menu on the main Display Touch Screen window.
- **SELECT** the **Define Form** procedure.

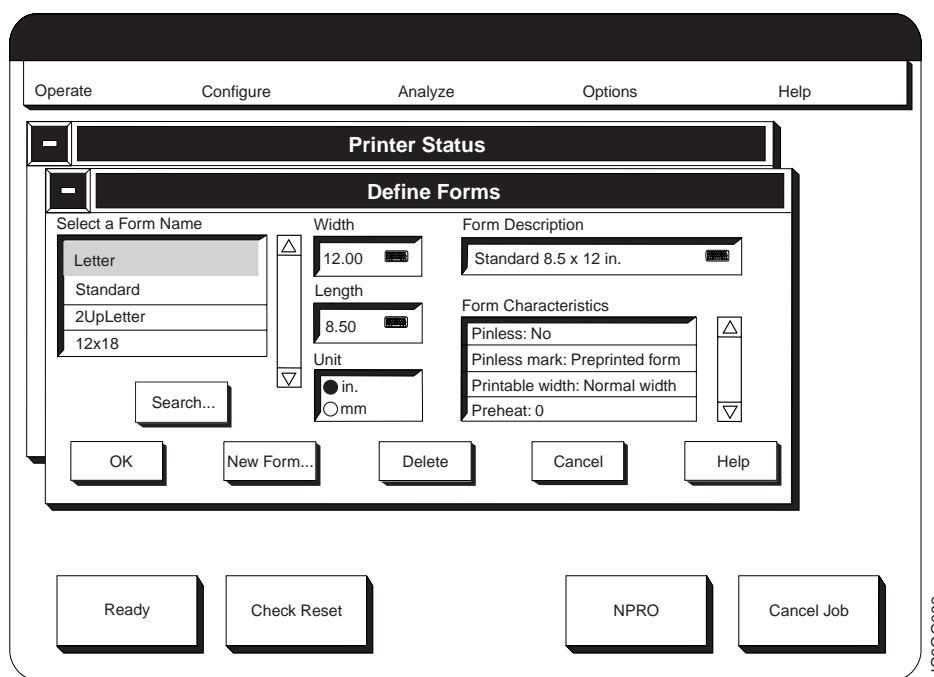

- **SELECT** the **Form Name** for which you want to change the preheat temperature.
- **SELECT** the **Preheat** field. A keypad window appears.
- **ENTER** the new temperature in increments of 5° (such as 75°, 85°, 90°).

**Note:** To use the default temperature that is set during printer configuration, **ENTER 0** (zero), not the default temperature.

- **SELECT** the **OK** pushbutton.
- Print several hundred feet of forms at the new temperature.
- Check the fusing to see if it is acceptable. If it is not, repeat the procedure.

## Poor Fusing - Simplex Mode

If poor fusing occurs on labels or heavy forms, increase the preheat temperature in 5° increments until the fusing is acceptable. Run several hundred feet of forms to stabilize the temperature. Check the fusing to see if it is acceptable.

If the fusing is *unacceptable*, increase the temperature by 5° and try printing again. If adequate fusing does not occur, the form may be unacceptable for use on the printers.

If the fusing is *acceptable*, examine the printed forms in the stacker to verify that the sheets are not sticking together, or that toner is not being pulled off adjacent sheets. If either condition exists, the form may be unacceptable for use on the printers. Evaluate the condition of the printed forms and consider the following:

- How long it took to print the job
- How long the forms were left in the stacker
- How much pressure was applied to the stack
- The type of application for which the forms are used, for example, bar-code readability.

## Forms Stick Together

- If forms stick together or toner is pulled off the forms in the stacker, *decrease* the preheat temperature by 5 degrees. Run several hundred feet of forms to stabilize the temperature. Check the fusing to see if it is *acceptable*.
- If the fusing is *acceptable* but forms stick together in the stacker, *decrease* the temperature by another 5 degrees and try printing again. If adequate fusing does not occur without forms sticking together, the forms may be unacceptable for use on the printers.
- Adjust the **Contrast** switch on the printer control panel to the *lowest* possible setting that produces acceptable print quality. Remember to adjust the contrast setting on both printers so that the contrast is balanced between the front and back side of the forms.
- Change the **Forms Select** setting on the stacker control panel to "C", if it is not already at that setting. Check the fusing to see if it is *acceptable*. If *unacceptable*, return the **Forms Select** to the previous setting. Increasing the print contrast may also improve fusing of solid areas and bar codes.

## Heat Damage — Printer Running

If heat damage (melting or curling) occurs to forms or labels while the printer is running, set the temperature to a *lower* value before you continue printing.

## Thread/Align Forms

Select this task when you load forms in duplex mode. This procedure is also automatically called when the system is powered-on in duplex mode and during some error and jam recovery procedures.

All of the controls you need to accomplish this procedure are available on the Display Touch Screen windows.

This procedure initially displays a Setup **Thread/Align Forms** window (see Figure 30).

### Notes:

1. Proper completion of this task is important to ensure that Printer 2 prints side 2 pages correctly opposite the side 1 pages that were previously printed by Printer 1.
2. You can print verification marks on both sides of the pages by using the **Verification marks** Printer Configuration Item. You can then visually inspect these marks to ensure that sides 1 and 2 of the forms are properly synchronized. See “Verification Marks” on page 224 for more information.
3. The dashed line is used to align the forms in the printers. The solid line is used to align postprocessing equipment if any is attached.

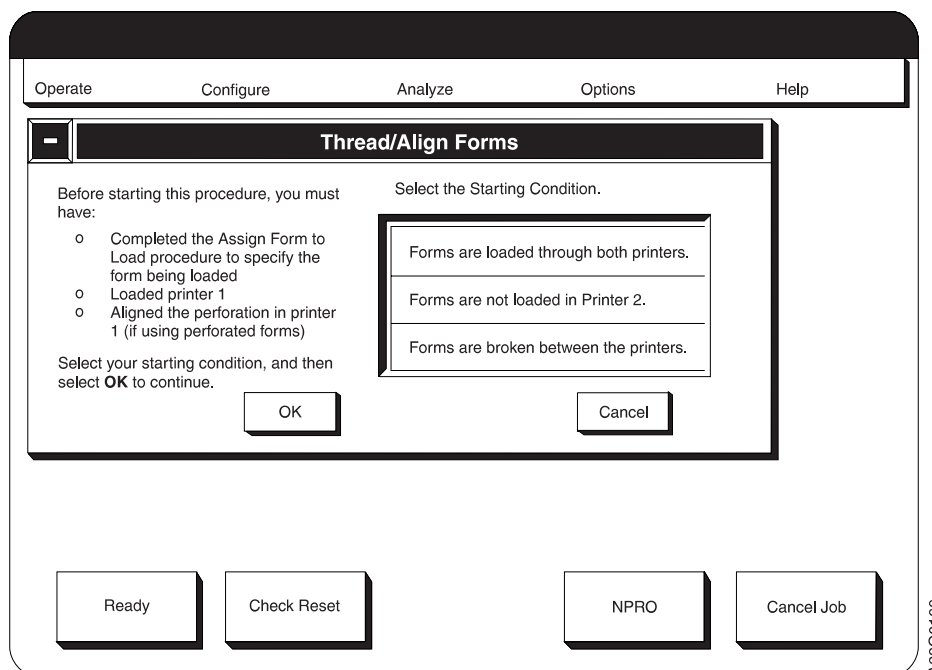

Figure 30. Setup Window for Thread/Align Forms

1. **SELECT** which of the conditions you want from the **Select a Starting Condition** box on the window. Your choice is highlighted.

The conditions you can select on this window are:

- **Forms are threaded through both printers:**

Select this when:



- The system has gone through a "Restart" procedure with forms that are loaded through both printers.
  - You are in a recovery procedure for an error condition or a forms jam that did not tear, damage, or separate the forms in the forms path through both printers.
  - The system power was switched off and then switched back on with unseparated forms threaded through both printers.
- **Forms are not loaded in printer 2:**  
Select this when:
    - You are loading a new type of form with different characteristics from the last form that you used in the system.
    - You are loading the same type of form that you previously used in the system; it was allowed to run out to end-of-forms; and it was flushed out of the printer so that a new supply of forms could not be spliced to the trailing edge of the old supply.
    - You are in a forms jam recovery procedure that separated the forms in a manner that you could not rejoin by splicing.
  - **Forms are broken between the printers:**  
Select this when you are recovering from a condition that separated the forms between Printer 1 and Printer 2 that you can rejoin by splicing.
2. If you **SELECT** the **Cancel** pushbutton on the window, the following actions occur:
- If you selected this procedure from the **Operate** pull-down menu, the **Thread/Align Forms** procedure closes with no actions taken.
  - If this procedure appeared automatically, the **Thread/Align Forms** procedure closes. However, any later attempt to make the printer Ready causes an **Intervention Required** Display Touch Screen window containing a "D206" SRC to appear. This requires **SELECTING** the **Thread/Align Forms** procedure and executing it before any printing actions can resume.

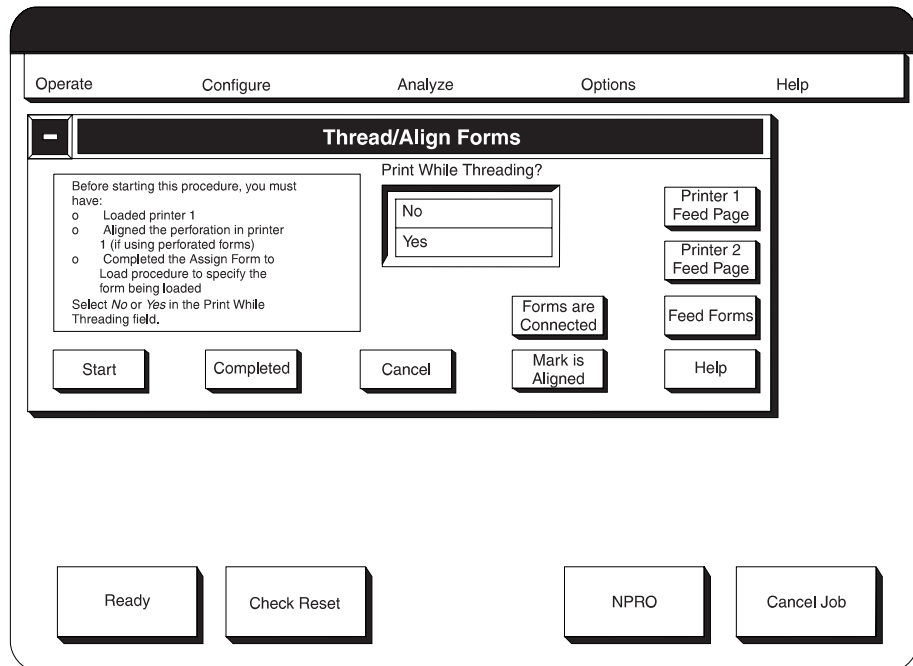

Figure 31. Main Thread/Align Forms Window

3. **SELECT** the **OK** pushbutton on the window. The main **Thread/Align Forms** procedure window (Figure 31) appears.

## Forms Are Loaded Through Both Printers

These procedures assume the following:

- You have visually checked the forms path through Printer 1, between Printer 1 and Printer 2, and through Printer 2 and found:
  - That the perforations are aligned with the alignment scale on the rear tractor covers.
  - That the forms path is not separated.
- A print job is queued, and host attachments are enabled if you intend to select the “Print While Threading” **Yes** option.

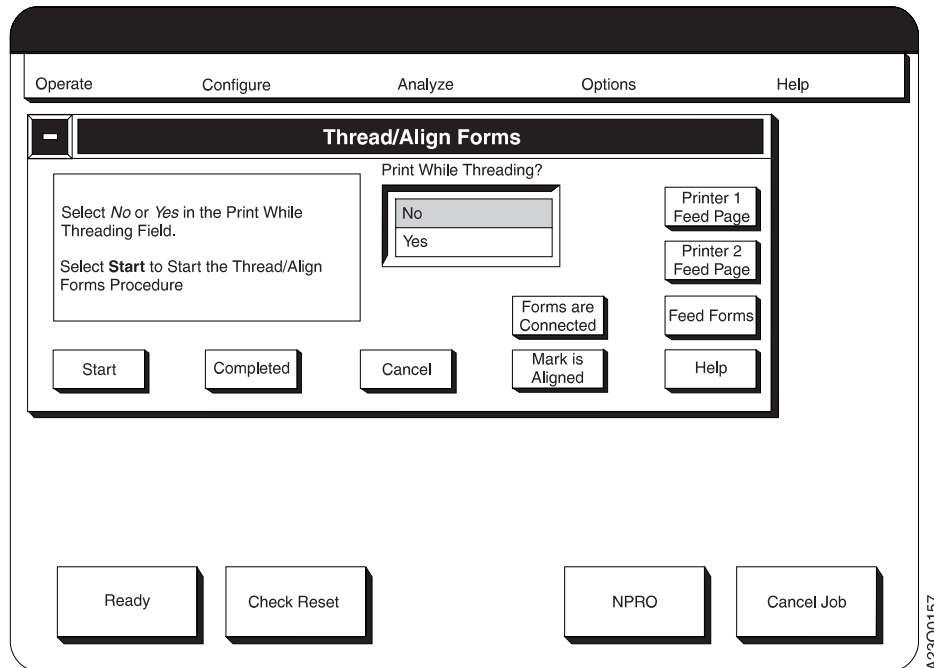

### Threading Without Printing

1. **SELECT** the **No** option within the **Print While Threading?** field.
2. **SELECT** the **Start** pushbutton.
3. **SELECT** the **Forms are Connected** pushbutton.
4. **SELECT** the **Feed to Align** pushbutton on the **Thread/Align Forms** window.
  - a. This prints a solid alignment mark after the leading edge on a page in Printer 1, which is designated as an alignment page.  
 A one-bar or two-bar pattern is also printed on the alignment page. The bar shows whether Side 1 or Side 2 of the form is being printed on Printer 1.  
 This prints a dashed alignment mark after the leading edge of the page.
  - b. This feeds a fixed length of forms through both Printer 1 and Printer 2.  
 The fixed length is based on the "Length of Forms Between Transfer Points" configuration item length that is shown on the **Configure Printer** window under the **Configure** pull-down menu. It is a multiple of the current loaded Form Name page length that is closest to the "Length of Forms Between Transfer Points" length without exceeding it.
5. Visually verify that the dashed alignment mark that is printed on Printer 1 is aligned to the appropriate alignment mark on the input station on Printer 2.
  - a. If the alignment mark is aligned at Printer 2, check to see if there is a sufficient buffer loop of forms between Printer 1 and the Buffer/Flipper Unit. If the buffer loop needs to be increased, change the "Length of Forms Between Transfer Points" printer configuration item. See the table item on page 223 for more information.
  - b. If the Printer 1 alignment mark is short of the alignment mark in Printer 2, **SELECT** the **Printer 2 Feed Page** pushbutton on Printer 2 as many times as necessary until the Printer 1 alignment mark is aligned at Printer 2.
  - c. If the Printer 1 alignment mark is past the alignment mark in printer 2, first add some more buffer loop between Printer 1 and the Buffer/Flipper Unit by **SELECTING** the **Printer 1 Feed Page** pushbutton several times. Then **SELECT** the **Cancel** pushbutton on the window.

You must now restart this **Thread/Align Forms** procedure by using the **Operate** menu.

6. After you have visually verified that the Printer 1 alignment mark is aligned correctly on Printer 2, **SELECT** the **Mark is Aligned** pushbutton on the window.

At the **Verification** window, **SELECT** the **OK** pushbutton.

This informs the control unit that the alignment is complete.

**Important**

If your visual verification of alignment is incorrect, the following duplex print jobs are printed with incorrect alignment between the front and back of the pages.

7. If a postprocessing device is installed and not threaded, **SELECT** the **Feed Forms** pushbutton on the window as many times as necessary to advance the forms enough to thread the postprocessing device.
8. **SELECT** the **Completed** pushbutton on the window that closes this window. This completes this type of Thread/Align Forms procedure.
9. **SELECT** the **Ready** pushbutton on the main Display Touch Screen window to begin printing.

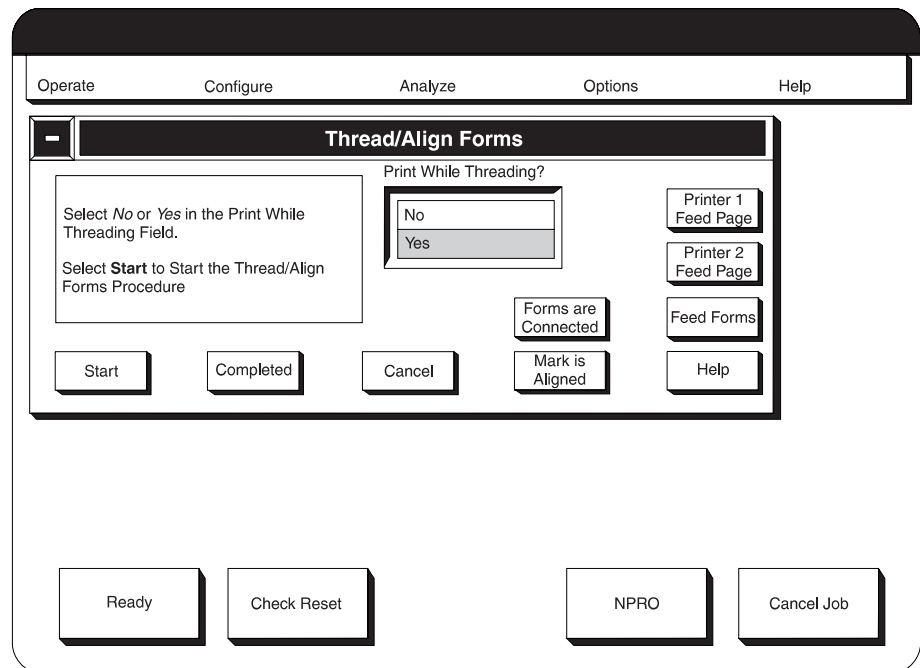

### Print While Threading

1. **SELECT** the **Yes** option within the **Print While Threading?** field.
2. **SELECT** the **Start** pushbutton.
3. **SELECT** the **Forms are Connected** pushbutton.
4. **SELECT** the **Feed to Align** pushbutton on the **Thread/Align Forms** window.
  - a. This prints a solid alignment mark after the leading edge on a page in Printer 1, which is designated as an alignment page.

A one-bar or two-bar pattern is also printed on the alignment page. The bar shows whether Side 1 or Side 2 of the form is being printed on Printer 1.

This prints a dashed alignment mark after the leading edge of the page.

- b. This feeds a fixed length of forms through both Printer 1 and Printer 2. The fixed length is based on the "Length of Forms Between Transfer Points" configuration item length shown on the **Configure Printer** window under the **Configure** pull-down menu. It is a multiple of the current loaded Form Name page length that is closest to the "Length of Forms Between Transfer Points" length without exceeding it.
  - c. Pages for the queued job are printed on Printer 1, starting on the page following the alignment page. Printer 2 processes blank pages.
5. If the queued job is too short to print all pages on Printer 1 for the complete "Length of Forms Between Transfer Points", the printing process ceases. The printers stop forward movement of the forms. A message appears in the non-selectable **Information** field on the window informing you that there is No Data to Print.

In this case you may either:

- **SELECT** the **No** option in the **Print While Threading?** field. Then **SELECT** the **Feed to Align** pushbutton to finish moving the alignment mark printed on Printer 1 to Printer 2.
  - Request the host system operator to send more print jobs to the system. Periodically **SELECT** the **Feed to Align** pushbutton. When more data is available, forward movement of the forms while printing resumes until the "Length of Forms Between Printers" distance is achieved.
6. When the queued and requested print jobs have satisfied the fixed length forward forms movement, visually verify that the dashed alignment mark that is printed on Printer 1 is aligned to the alignment mark on the input station on Printer 2.
- a. If the alignment mark is aligned at Printer 2, check to see if there is a sufficient buffer loop of forms between Printer 1 and the Buffer/Flipper Unit. If the buffer loop needs to be increased, change the "Length of Forms Between Transfer Points" printer configuration item. See the table item on page 223 for more information.
  - b. If the Printer 1 alignment mark is short of the alignment mark in Printer 2, **SELECT** the **Printer 2 Feed Page** pushbutton as many times as necessary until the Printer 1 alignment mark is aligned at Printer 2.
  - c. If the Printer 1 alignment mark is past the alignment mark in printer 2, first add some more buffer loop between Printer 1 and the Buffer/Flipper Unit by **SELECTING** the **Printer 1 Feed Page** pushbutton several times. Then **SELECT** the **Cancel** pushbutton on the window.

You must now restart this **Thread/Align Forms** procedure.

7. After you visually verify that the Printer 1 alignment mark is aligned correctly on Printer 2, **SELECT** the **Mark is Aligned** pushbutton on the window.

At the **Verification** window, **SELECT** the **OK** pushbutton.

This informs the control unit that the alignment is complete.

**Important**

If your visual verification of alignment is incorrect, all following duplex print jobs are printed with incorrect alignment between the front and back of the pages.

8. If a postprocessing device is installed and not threaded, **SELECT** the **Feed Forms** pushbutton on the window as many times as necessary to advance the forms enough to thread the postprocessing device.  
Printer 2 prints Side 2 pages starting on the page following the alignment page during these forms forward movements. If the queued job is long enough, Printer 1 continues printing Side 1 pages.
9. **SELECT** the **Completed** pushbutton on the window.  
This completes this type of Thread/Align Forms procedure.
10. To resume printing the queued job, **SELECT** the **Ready** pushbutton on the main Display Touch Screen window.

## Forms Are Not Loaded In Printer 2

These procedures assume the following:

- You have visually checked that forms have been threaded in Printer 1, and forms are not loaded in Printer 2.
- The main **Thread/Align Forms** procedure window appears on the Display Touch Screen.
- A print job is queued if you intend to select the “Print While Threading” **Yes** option.

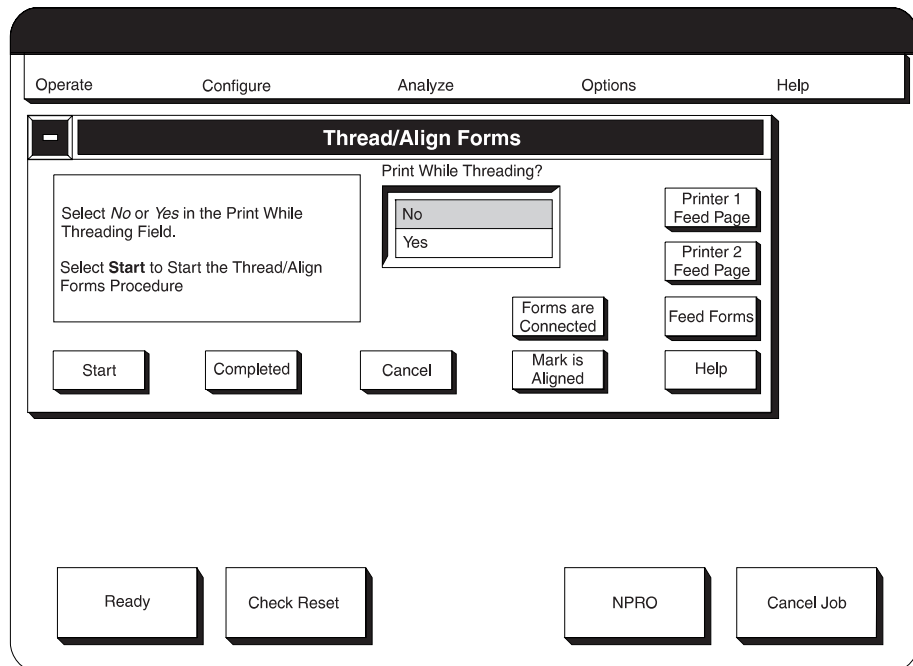

### Threading Without Printing

1. **SELECT** the **No** option within the **Print While Threading?** field.
2. **SELECT** the **Start** pushbutton.

3. **SELECT** the **Feed Forms** pushbutton on the **Thread/Align Forms** window.
  - a. This prints a solid alignment mark after the leading edge on a page in Printer 1, which is designated as an alignment page.  
A one-bar or two-bar pattern is also printed on the alignment page. The bar shows whether Side 1 or Side 2 of the form is being printed on Printer 1.  
This prints a dashed alignment mark after the leading edge of the page.
  - b. This feeds a fixed length of forms through Printer 1.  
The fixed length is based on the "Form Feed Length" configuration item shown on the **Configure Printer** window under the **Configure** pull-down menu. It is a multiple of the current loaded Form Name page length that is closest to the "Form Feed Length" without exceeding it.
4. Continue **SELECTING** the **Feed Forms** pushbutton on the window for Printer 1 until the forms do not advance any further.  
Enough forms should have moved through Printer 1 to manually thread the Buffer/Flipper Unit (see "Threading the Buffer/Flipper Unit" on page 167 for details). Advance the forms under Printer 2 into the input area of Printer 2, and thread Printer 2.  
The **Feed Forms** pushbutton on the window for Printer 1 becomes inoperable when a multiple of the current loaded Form Name page length that is closest to but not exceeding the length in the "Length of Forms Between transfer Points" configuration item shown on the **Configure Printer** window under the **Configure** pull-down menu has moved through Printer 1.  
When the **Feed Forms** pushbutton and the **Feed** pushbutton are inoperable and additional length is needed to supply enough forms to thread Printer 2, **SELECT** the **Printer 1 Feed Page** pushbutton on the window.
5. After enough forms have moved through Printer 1 and the Buffer/Flipper Unit, and you have created a buffer big enough between the Buffer/Flipper Unit and Printer 2 to allow you to thread Printer 2, do the following:
  - a. Remove power from the Urge Unit in the Forms Input area of Printer 2. The Urge Unit cannot be threaded while the roller is moving.
  - b. Thread forms through the Urge Unit.
  - c. Restore power to the Urge Unit.
6. Follow the steps in the "Loading Forms (Duplex Mode)" on page 115 to thread Printer 2.
7. Visually verify that the dashed alignment mark that is printed on Printer 1 is aligned to the alignment mark on the input station on Printer 2.
  - a. If the alignment mark is aligned at Printer 2, check to see if there is a sufficient buffer loop of forms between Printer 1 and the Buffer/Flipper Unit. If you need to increase the buffer loop, change the "Length of Forms Between Transfer Points" printer configuration item. See the table item on page 223 for more information.
  - b. If the Printer 1 alignment mark is short of the alignment mark in Printer 2, **SELECT** the **Printer 2 Feed Page** pushbutton as many times as necessary until the Printer 1 alignment mark is aligned at Printer 2.
  - c. If the Printer 1 alignment mark is past the alignment mark in printer 2, first add some more buffer loop between Printer 1 and the Buffer/Flipper Unit by **SELECTING** the **Printer 1 Feed Page** pushbutton several times. Then **SELECT** the **Cancel** pushbutton on the window.

You must now restart this **Thread/Align Forms** procedure.

8. After you have visually verified that the Printer 1 alignment mark is aligned correctly on Printer 2, **SELECT** the **Mark is Aligned** pushbutton on the window.

At the **Verification** window, **SELECT** the **OK** pushbutton.

This informs the control unit that the alignment is complete.

**Important**

If your visual verification of alignment is incorrect, all following duplex print jobs are printed with incorrect alignment between the front and back of the pages.

9. If a postprocessing device is installed and not threaded, **SELECT** the **Feed Forms** pushbutton on the window as many times as necessary to advance the forms enough to thread the postprocessing device.
10. **SELECT** the **Completed** pushbutton on the window.  
This completes this type of Thread/Align Forms procedure.
11. To begin printing, **SELECT** the **Ready** pushbutton on the main Display Touch Screen window.

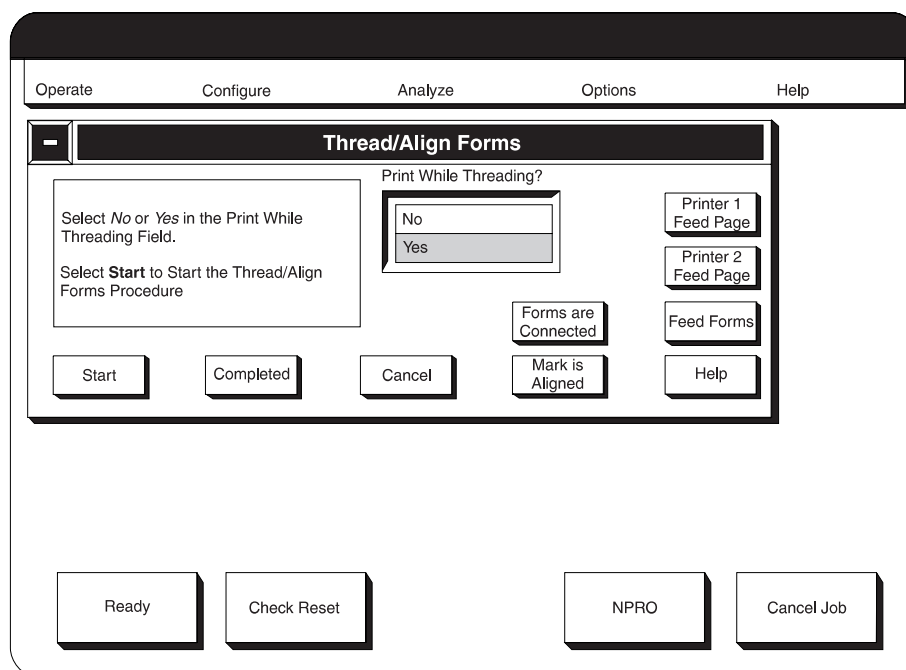

### Print While Threading

1. **SELECT** the **Yes** option within the **Print While Threading?** field.
2. **SELECT** the **Start** pushbutton.  
This informs the control unit to begin the thread/align process.
3. **SELECT** the **Feed Forms** pushbutton on the **Thread/Align Forms** window.
  - a. This prints a solid alignment mark after the leading edge on a page in Printer 1, which is designated as an alignment page.  
A one-bar or two-bar pattern is also printed on the alignment page. The bar shows whether Side 1 or Side 2 of the form is being printed on Printer 1.



This prints a dashed alignment mark after the leading edge of the page.

- b. This feeds a fixed length of forms through Printer 1.

The fixed length is based on the "Form Feed Length" configuration item that is shown on the **Configure Printer** window under the **Configure** pull-down menu. It is a multiple of the current loaded Form Name page length that is closest to the "Form Feed Length" without exceeding it.

- c. Pages for the queued job are printed on Printer 1 starting on the page following the alignment page during this and following selections of the **Feed Forms** pushbutton. Printer 2 processes blank pages.
4. Continue **SELECTING** the **Feed Forms** pushbutton on the window for Printer 1 until the forms do not advance any further.

Enough forms should have moved through Printer 1 to do the following:

- a. Manually thread the Buffer/Flipper Unit (see "Threading the Buffer/Flipper Unit" on page 167 for details).
- b. Advance the forms under Printer 2 into the input area of Printer 2.
- c. Thread Printer 2.

The **Feed Forms** pushbutton for Printer 1 becomes inoperable when a multiple of the current loaded Form Name page length that is closest to but not exceeding the length in the "Length of Forms Between Transfer Points" configuration item shown on the **Configure Printer** window under the **Configure** pull-down menu has moved through Printer 1.

When the **Feed Forms** pushbutton and the **Feed** pushbutton are inoperable and you need additional length to supply enough forms to thread Printer 2, **SELECT** the **Printer 1 Feed Page** pushbutton on the window on the Printer 1.

5. If the queued job is too short to print all pages on Printer 1 for the complete "Length of Forms Between Transfer Points", the **Feed Forms** window pushbutton and the **Feed** pushbutton become inoperable before the "Length of Forms Between Transfer Points" is achieved. A message appears in the non-selectable **Information** field on the window informing you that there is No Data to Print.

In this case you may either:

- **SELECT** the **No** option in the **Print While Threading** field. This restores use of the **Feed Forms** pushbutton and the **Feed** pushbutton so that you may continue with the threading process.
- Request the host system operator to send more print jobs to the system, which when received, resumes printing operations on Printer 1.

Periodically **SELECT** the **Feed Forms** pushbutton. When more data is available, forward movement of the forms while printing resumes until the "Length of Forms Between Printers" distance is achieved.

6. After enough forms have moved through Printer 1 and the Buffer/Flipper Unit and have created a buffer big enough between the Buffer/Flipper Unit and Printer 2 to allow you to thread Printer 2, do the following:
  - a. Remove power from the Urge Unit in the Forms Input area of Printer 2. You cannot thread the Urge Unit while the roller is moving.
  - b. Thread forms through the Urge Unit.
  - c. Restore power to the Urge Unit.
7. Follow the steps in "Loading Forms (Duplex Mode)" on page 115 to thread Printer 2.

8. Visually verify that the dashed alignment mark that is printed on Printer 1 is aligned to the alignment mark on the input station on Printer 2.
  - a. If the alignment mark is aligned at Printer 2, check to see if there is a sufficient buffer loop of forms between Printer 1 and the Buffer/Flipper Unit. If you need to increase the buffer loop, change the "Length of Forms Between Transfer Points" printer configuration item. See the table item on page 223 for more information.
  - b. If the Printer 1 alignment mark is short of the appropriate forms length scale mark in Printer 2, **SELECT** the **Printer 2 Feed Page** pushbutton as many times as necessary until the Printer 1 alignment mark is aligned at Printer 2.
  - c. If the Printer 1 alignment mark is past the forms length scale mark in printer 2, first add some more buffer loop between Printer 1 and the Buffer/Flipper Unit. Do this by **SELECTING** the **Printer 1 Feed Page** pushbutton several times, and then **SELECTING** the **Cancel** pushbutton on the window.

You must now restart this **Thread/Align Forms** procedure.

9. After you have visually verified that the Printer 1 alignment mark is aligned correctly on Printer 2, **SELECT** the **Mark is Aligned** pushbutton on the window.

At the **Verification** window, **SELECT** the **OK** pushbutton.

This informs the control unit that the alignment is complete.

#### **Important**

If your visual verification of alignment is incorrect, all following duplex print jobs are printed with incorrect alignment between the front and back of the pages.

10. If a postprocessing device is installed and not threaded, **SELECT** the **Feed Forms** pushbutton on the window as many times as necessary to advance the forms enough to thread the postprocessing device.  
Printer 2 starts printing Side 2 pages on the page following the alignment page. If the job is long enough, Printer 1 continues printing Side 1 pages.
11. **SELECT** the **Completed** pushbutton on the window.  
This completes this type of the Thread/Align Forms procedure.
12. To resume printing the queued job, **SELECT** the **Ready** pushbutton on the main Display Touch Screen window.

## **Forms Are Broken Between the Printers**

A jam occurring between Printer 1 and Printer 2 normally causes the forms to tear and separate. Printer 1 continues to print and dump forms out on the floor between Printer 1 and Printer 2. Printer 2 feeds forms and prints until an **END OF FORMS 078A Intervention Required** Display Touch Screen window appears. At which time both printers stop feeding forms.

The following procedure gives you a method of splicing the separated forms back together between Printer 1 and Printer 2, so that rethreading Printer 2 and a postprocessing device (if installed) is not required.

This procedure assumes the following:

- You have visually checked the forms path and found it separated between Printer 1 and Printer 2.
- The main **Thread/Align Forms** procedure window appears on the Display Touch Screen.
- A print job is queued, and host attachments are enabled if the “Print While Threading” option is selected.

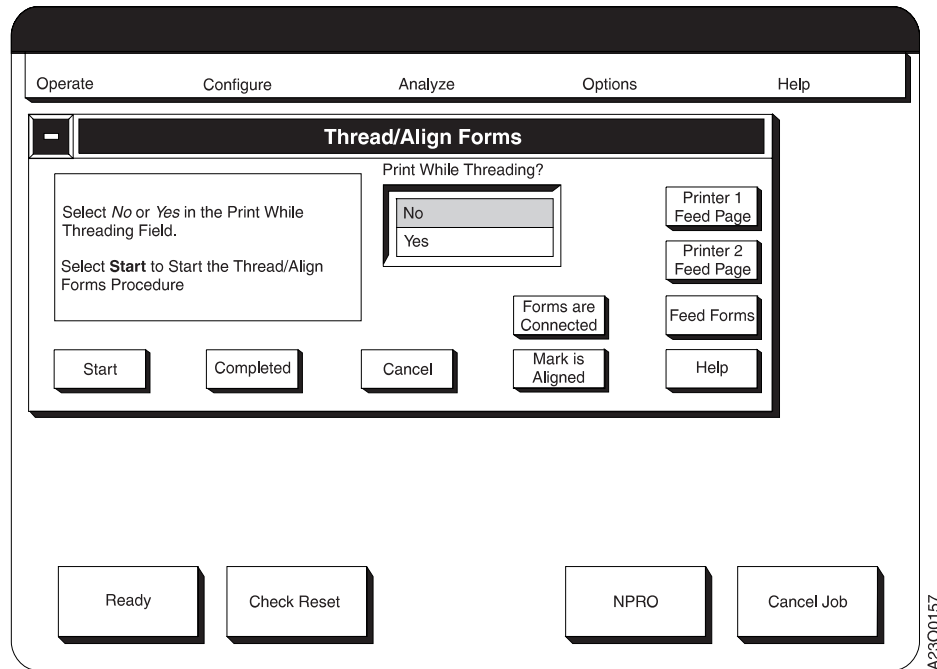

### Threading Without Printing

1. **SELECT** the **No** option within the **Print While Threading?** field.
2. **SELECT** the **Start** pushbutton.
3. If no forms were damaged and there is enough slack in the forms, splice the forms together.  
Go to step 5 on page 164.
4. If forms were damaged and must be removed or there is not enough slack to splice the forms back together, use either the **Feed Forms** or **Printer 1 Feed Page** pushbuttons to advance the forms through Printer 1 enough to splice the forms together. The first selection of either the **Feed Forms** or the **Printer 1 Feed Page** pushbutton does the following:
  - a. This prints a solid alignment mark after the leading edge on a page in Printer 1, which is designated as an alignment page.  
A one-bar or two-bar pattern is also printed on the alignment page. The bar shows whether Side 1 or Side 2 of the form is being printed on Printer 1.  
This prints a dashed alignment mark after the leading edge of the page.
  - b. Feeds a fixed length of forms through Printer 1. This is either the length set in the **Form Feed Length** printer configuration item if you select the **Feed Forms** pushbutton or the length of one page according the page length definition for the Form Name currently loaded if you select the **Printer 1 Feed Page** pushbutton.

After you have completed the splicing procedure, go to step 5.

5. **SELECT** the **Forms are Connected** pushbutton.
6. **SELECT** the **Feed to Align** pushbutton on the **Thread/Align Forms** window.
7. Visually verify that the dashed alignment mark that is printed on Printer 1 is aligned to the alignment mark on the input station on Printer 2.
  - a. If the alignment mark is aligned at Printer 2, check to see if there is a sufficient buffer loop of forms between Printer 1 and the Buffer/Flipper Unit. If you need to increase the buffer loop, change the "Length of Forms Between Transfer Points" printer configuration item. See the table item on page 223 for more information.
  - b. If the Printer 1 alignment mark is short of the alignment mark in Printer 2, **SELECT** the **Printer 2 Feed Page** pushbutton on the window as many times as necessary until the Printer 1 alignment mark is aligned at Printer 2.
  - c. If the Printer 1 alignment mark is past the alignment mark in printer 2, first add some more buffer loop between Printer 1 and the Buffer/Flipper Unit by **SELECTING** the **Printer 1 Feed Page** pushbutton several times. Then **SELECT** the **Cancel** pushbutton on the window.

You must now restart this **Thread/Align Forms** procedure.

8. After you have visually verified that the Printer 1 alignment mark is aligned correctly on Printer 2, **SELECT** the **Mark is Aligned** pushbutton on the window.

At the **Verification** window, **SELECT** the **OK** pushbutton.

This informs the control unit that the alignment is complete.

**Important**

If your visual verification of alignment is incorrect, all following duplex print jobs are printed with incorrect alignment between the front and back of the pages.

9. If a postprocessing device is installed and not threaded, **SELECT** the **Feed Forms** pushbutton on the window as many times as necessary to advance the forms enough to thread the postprocessing device.
10. **SELECT** the **Completed** pushbutton on the window that removes this window.

This completes this type of Thread/Align Forms procedure.
11. To begin printing, **SELECT** the **Ready** pushbutton on the main Display Touch Screen window.

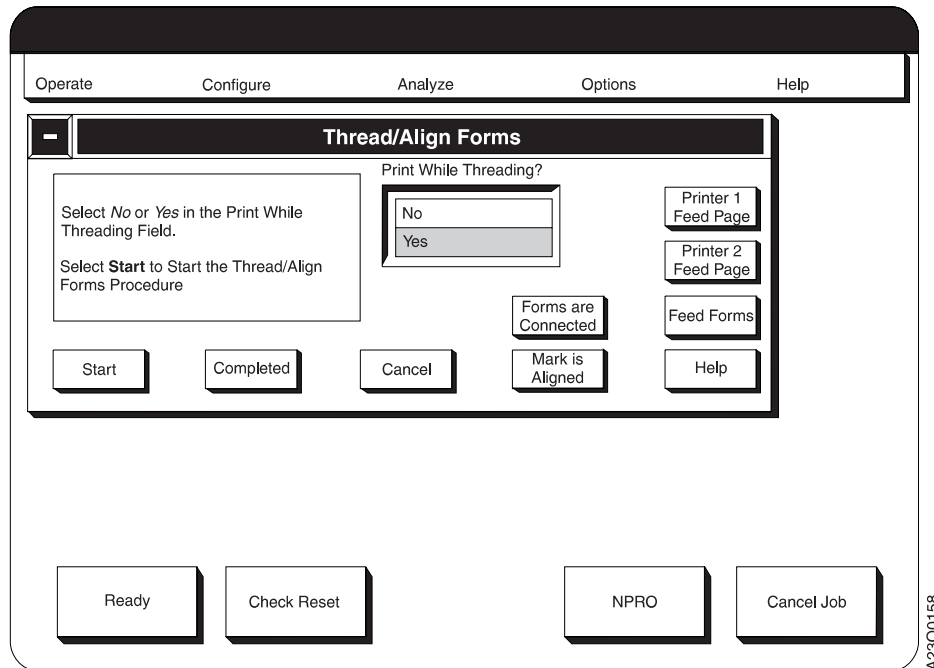

## Printing While Threading

1. **SELECT** the **Yes** option within the **Print While Threading?** field.
2. **SELECT** the **Start** pushbutton.

This informs the control unit to begin the thread/align process.

3. If no forms were damaged and there is enough slack in the forms, splice the forms back together.  
Go to step 5.
4. If forms must be removed or there is not enough slack to splice the forms back together, use the **Feed Forms** or **Printer 1 Feed Page** pushbuttons to advance the forms through Printer 1 enough to splice the forms together. The first selection of either the **Feed Forms** or the **Printer 1 Feed Page** pushbutton does the following:
  - a. This prints a solid alignment mark after the leading edge on a page in Printer 1, which is designated as an alignment page.  
A one-bar or two-bar pattern is also printed on the alignment page. The bar shows whether Side 1 or Side 2 of the form is being printed on Printer 1.  
This prints a dashed alignment mark after the leading edge of the page.
  - b. Feeds a fixed length of forms through Printer 1 either the length set in the **Form Feed Length** printer configuration item if you select the **Feed Forms** pushbutton or the length of one page according to the page length definition for the Form Name currently loaded if you select the **Printer 1 Feed Page** pushbutton.
  - c. Prints pages for the queued job on Printer 1, starting on the page following the alignment page. Printer 2 processes blank pages.
5. **SELECT** the **Forms are Connected** pushbutton.
6. **SELECT** the **Feed to Align** pushbutton on the **Thread/Align Forms** window.

Pages for the queued job are printed on Printer 1, starting on the page following the alignment page. Printer 2 processes blank pages.

7. If the queued job is too short to print all pages on Printer 1 for the complete "Length of Forms Between Transfer Points", the printing process ceases. The printers stop forward movement of the forms. A message appears in the non-selectable **Information** field on window informing you that there is No Data to Print.

In this case you may either:

- **SELECT** the **No** option in the **Print While Threading?** field or **SELECT** the **Start** pushbutton and follow the procedure steps in "Threading Without Printing" on page 163. Printing while threading cannot be accomplished with the current queued job.
  - Periodically **SELECT** the **Feed to Align** pushbutton. When more data is available, forward movement of the forms while printing resumes until the "Length of Forms Between Printers" distance is achieved.
8. If the queued job is long enough and the fixed-length forms forward movement completes, visually verify that the dashed alignment mark printed on Printer 1 is aligned to the alignment mark on the input station on Printer 2.
    - a. If the alignment mark is aligned at Printer 2, check to see if there is a sufficient buffer loop of forms between Printer 1 and the Buffer/Flipper Unit. If you need to increase the buffer loop, change the "Length of Forms Between Transfer Points" printer configuration item. See the table item on page 223 for more information.
    - b. If the Printer 1 alignment mark is short of the alignment mark in Printer 2, **SELECT** the **Printer 2 Feed Page** pushbutton on the window as many times as necessary until the Printer 1 alignment mark is aligned at Printer 2.
    - c. If the Printer 1 alignment mark is past the alignment mark on printer 2, first add some more buffer loop between Printer 1 and the Buffer/Flipper Unit by **SELECTING** the **Printer 1 Feed Page** pushbutton several times. Then **SELECT** the **Cancel** pushbutton on the window.

You must now restart this **Thread/Align Forms** procedure.

9. After you have visually verified that the Printer 1 alignment mark is aligned correctly on Printer 2, **SELECT** the **Mark is Aligned** pushbutton on the window.

At the **Verification** window, **SELECT** the **OK** pushbutton.

This informs the control unit that the alignment is complete.

**Important**

If your visual verification of alignment is incorrect, all following duplex print jobs are printed with incorrect alignment between the front and back of the pages.

10. If a postprocessing device is installed and not threaded, **SELECT** the **Feed Forms** pushbutton on the window as many times as necessary to advance the forms enough to thread the postprocessing device.
11. **SELECT** the **Completed** pushbutton on the window which removes this window.

This completes this type of Thread/Align Forms procedure.
12. To resume printing the queued job, **SELECT** the **Ready** pushbutton on the main Display Touch Screen window.

---

## Threading the Buffer/Flipper Unit

### Straight Line Configuration

Figure 32 shows the Buffer/Flipper Unit viewed from the front. The darker shaded side of the forms in Figure 32 is the side that is printed on Printer 1. The lighter shaded side of the forms is the side that is printed on Printer 2.

Use Figure 32 to thread the forms through the Buffer/Flipper Unit using the arrows as a guide from Printer 1 at the top of the figure to Printer 2 at the bottom of the figure. The result is that the forms are inverted 180° between Printer 1 and Printer 2.

The guide collars (A) through (F) on the roller bars were adjusted properly when the system was initially installed. Adjustments by you are probably not necessary, even if you are threading a form through the system with a different width than you previously threaded. When the forms are under tension and moving through the Buffer/Flipper Unit, they run up against the guide collars that are shown.

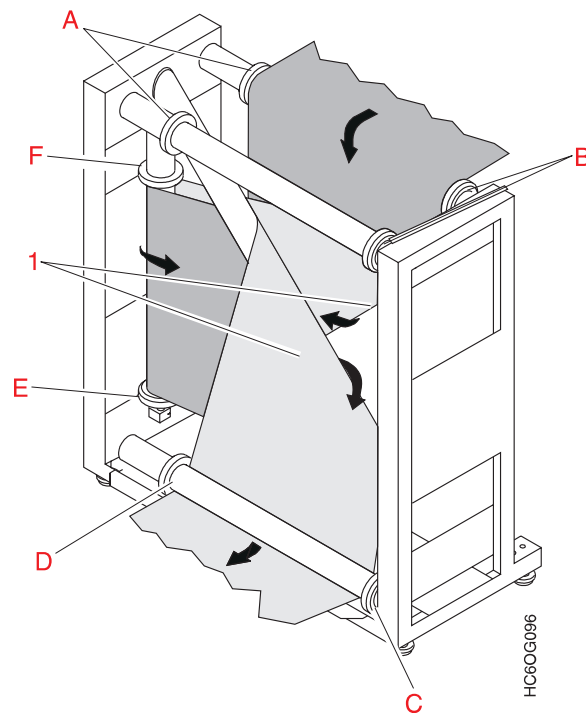

Figure 32. Inline Configuration

## Left Angle Configuration

Figure 33 shows the Buffer/Flipper Unit viewed from the front. The darker shaded side of the forms in Figure 33 is the side that is printed on Printer 1. The lighter shaded side of the forms is the side that is printed on Printer 2.

The longer of the two cross bars (1) is removed from its normal position. It is then installed at the lower back of the Buffer/Flipper Unit with the support bar (2).

Use Figure 33 to thread the forms through the Buffer/Flipper Unit using the arrows as a guide from Printer 1 at the top of the figure to Printer 2 at the bottom of the figure. The result is that the forms are inverted 180° between Printer 1 and Printer 2.

The guide collars (A) through (F) on the roller bars were adjusted properly when the system was initially installed. Adjustments by you are probably not necessary, even if you are threading a form through the system with a different width than you previously threaded. When the forms are under tension and moving through the Buffer/Flipper Unit, they run up against the guide collars that are shown.

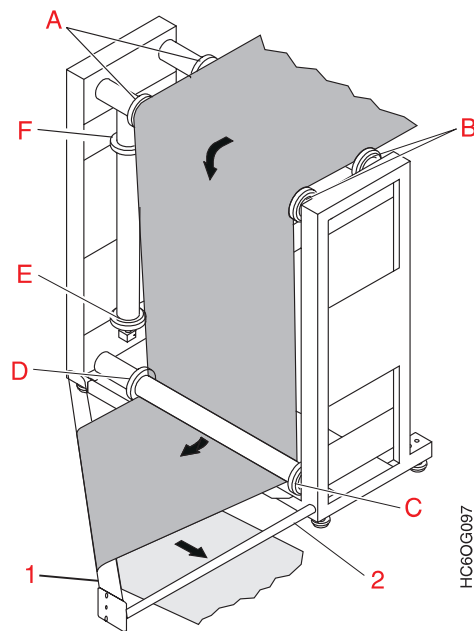

Figure 33. Left Angle Configuration



## Unloading the Stacker

Do this task when you need to remove printed forms from the stacker or when you see the following message:

STACKER FULL 0796

Some controls you need to use to accomplish this task are available only on the stacker control panel, and some are available on the Display Touch Screen window.

1. If you need to stop the printer, **SELECT** the **Stop** pushbutton on the Display Touch Screen window.
2. If you need to remove all the current forms from the forms path, separate the forms at a perforation below the transfer station. Ensure that the end-of-forms sensors are uncovered. Open the static brush so the forms fall back into the box or input area.
3. If you need to move forms to the stacker, **SELECT** the **NPRO** pushbutton on the Display Touch Screen window.

If END OF FORMS appears, repeat this step again.

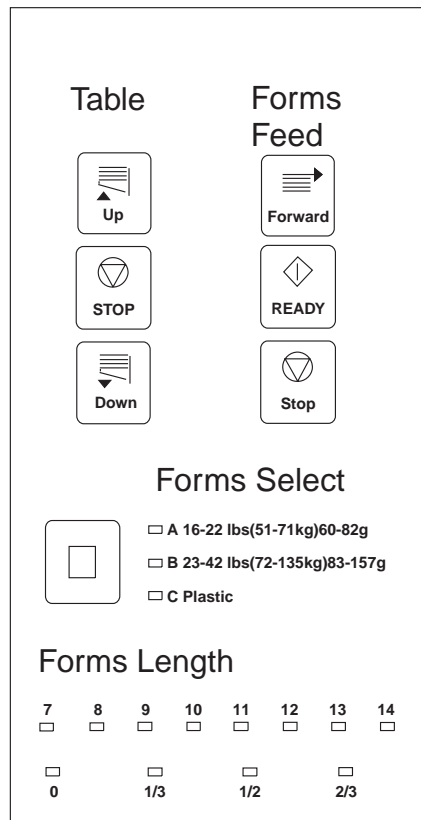

4. On the stacker control panel, press the stacker table **Down** switch and wait for the stacker table to stop moving.

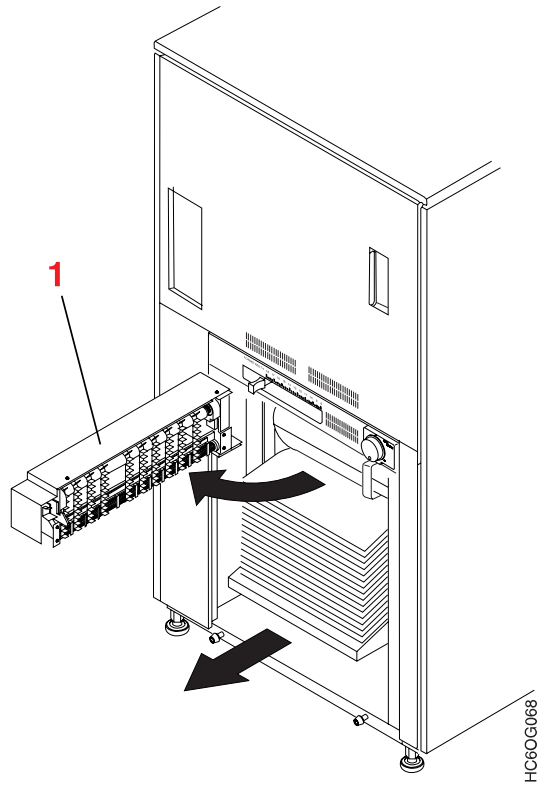

5. Open the stacker gate (1).
6. If you did not do an NPRO, leave four to five pages of blank forms attached to the end of the job. This ensures correct folding when you resume printing.



**CAUTION:**

<74> The weight of the paper in the stacker can be very heavy.

CAUTO104

### Operator Tips on Removing Forms From The Stacker

*Do not attempt to remove a full stack from the stacker.*

- Limit the maximum weight of the stack by breaking the output into small stacks (start with 150 mm (6 in.) high) by separating the forms at convenient perforations.
- Use a ruler, knife, or letter opener to break hard-to-reach perforations when you separate forms.
- Follow these guidelines when you lift forms out of the stacker:
  - a. Ensure that you can stand safely without slipping.
  - b. Try to keep your back straight and balance the weight of the forms between your feet.
  - c. Use a slow lifting force. Never move suddenly or twist when you attempt to lift.
  - d. Lift by standing or by pushing up with your leg muscles. This action removes the strain from the muscles in your back.

7. Remove the output from the stacker.
8. On the stacker control panel, press the stacker table **UP** switch.
9. Close the stacker gate.
10. To continue, **SELECT** the **Ready** pushbutton on the Display Touch Screen window.

### Note on Adjusting the Height of the Output Stack

You can adjust the stacker table to limit the output stack height and weight. Raising the stacker table lessens the height and weight of the stack, but causes the STACKER FULL message to appear more frequently. To adjust the stacker table height, see “Adjusting the Stacker Table Height” on page 117.

---

## Switching Printer Modes (Dual Simplex/Duplex)

Use these procedures to switch between duplex and dual simplex modes on Models ED1/ED2.

**Note:** Do not change the print mode in combination with any other configuration changes. You must do it separately. Make other configuration changes *after* the printer is in the correct print mode.

### Switching from Duplex to Dual Simplex Mode

1. To stop the printer, **SELECT** the **Stop** pushbutton on the Display Touch Screen.
2. **SELECT** the **Configure** pull-down menu on the main Display Touch Screen window.
3. **SELECT** the **Configure Printer** procedure. The **Configure Printer** window appears.
4. Find and **SELECT** the **Printer Mode** item.
5. **SELECT** the **Simplex** item.
6. **SELECT** the **OK** pushbutton.
7. **SELECT Restart** when this prompt appears.
8. A window appears that informs you that an automatic **Shutdown** procedure has started. This is followed by a window that states that the system is being “rebooted” (reloading AFCCU microcode). At the completion of the microcode reload, the Printer Mode change is in effect (one of the main simplex printer Display Touch Screen windows appears).

**Note:** No system power-off and power-on procedure is required.

9. To remove any forms still in the printer, see “Clearing the Forms Path” on page 136.
10. Load paper and assign forms in both printers for dual simplex operation (see “Loading Forms (Simplex or Dual Simplex Mode)” on page 102).
11. **SELECT** the **Ready** pushbutton.

For additional information, see “Chapter 8. Configuring the System” on page 217.

### Switching from Dual Simplex to Duplex Mode

1. To stop the printer, **SELECT** the **Stop** pushbutton on the Display Touch Screen.
2. **SELECT** the **Configure** pull-down menu on the Display Touch Screen window.
3. **SELECT** the **Configure Printer** procedure. The **Configure Printer** window appears.
4. Find and **SELECT** the **Printer Mode** item.
5. **SELECT** the **Duplex** item.
6. **SELECT** the **OK** pushbutton.
7. **SELECT Restart** when this prompt appears.
8. **SELECT** the **OK** pushbutton.
9. The Second Simplex window appears. You must select the **Shutdown/Restart** procedure from the **Operate** pull-down menu on that Display Touch Screen,

| and then execute the **Shutdown** routine. A window appears stating that the  
| system is shutting down. A second window appears stating that the system is  
| being “rebooted”. At the completion of the reboot, the Printer Mode change is  
| in effect (the Duplex main Display Touch Screen window appears).

| **Note:** No system power-off and power-on procedure is required.

- | 10. To remove any forms still in the printer, see “Clearing the Forms Path” on  
| page 136.
- | 11. Load paper and assign the form for duplex operation (see “Loading Forms  
| (Duplex Mode)” on page 115).
- | 12. Perform the Thread/Align Forms procedure (see page 152).
- | 13. **SELECT** the **Ready** pushbutton.

For additional information, see “Chapter 8. Configuring the System” on page 217.

---

## Switching Print Resolution

Use this procedure to select the print resolution for a print job when it requires a different print resolution than is currently in use.

**Note:** Do not change the print resolution in combination with any other configuration changes. You must do it separately.

1. **SELECT** the **Configure** pull-down menu on the Display Touch Screen window.
2. **SELECT** the **Configure Printer** procedure. The **Configure Printer** window appears.
3. **SELECT** the **Printhead Resolution: XXX** item, where XXX is the current print resolution configuration. The **Printhead Resolution** window appears listing the valid dots-per-inch (DPI) resolution numbers.
4. **SELECT** the appropriate resolution number.  
If you select 600 DPI, another window appears. This window shows the current IPDS resolution. **Select** the desired IPDS resolution.
5. If you select 480 DPI (or 600 DPI in combination with 240, 300, 600, or Auto IPDS resolution), the **Enhanced Fonts** window appears. You must select Yes or No for Single-byte and Double-byte Font Enhancements.
6. **SELECT** the **OK** pushbutton on the **Configure Printer** window. The print resolution is now at the number you selected.

---

## Chapter 7. Ordering and Replacing Supplies

Supplies . . . . .	176	Changing the Toner Cartridge . . . . .	182
IBM Supplies Worksheet . . . . .	176	Checking the Toner Collector . . . . .	186
Ordering Supplies . . . . .	177	Changing the Toner Collector . . . . .	188
Maintenance Supply Items. . . . .	177	Changing the Developer Mix . . . . .	191
Customer-Replaceable Supply Items . . . . .	177	Checking the Fine Filter . . . . .	200
Warranty Returns. . . . .	178	Changing the Fine Filter . . . . .	201
Storing Supplies . . . . .	178	Changing the Oiler Belt. . . . .	204
Adding Fuser Oil. . . . .	179	Checking the Absorbent Pad in the Oil Pan . . . . .	212

This section describes how to order and replace supplies. Tasks in this section are presented in an arbitrary order; not in order of importance or frequency of use.

A message appears on an Display Touch Screen window when it is time to replace, add, or check a supply item.

---

## Supplies

For optimum reliability and print quality use IBM supplies, which are engineered specifically for IBM printers. Use the “IBM Supplies Worksheet” to help you order supplies for the printer before the system is delivered, and to maintain a stock of supplies for continuous operation.

When a printer runs low on a supply item, it displays a status message on the Display Touch Screen screen, sounds an alarm, and turns on an operator intervention light on top of the printer.

IBM recommends that you keep the following quantities on hand per print engine:

Item	Suggested Quantity
Toner	30 cartridges
Developer mix	4 bottles
Fuser oil	4 bottles
Oiler belt	2 belts
Fine filter	2 filters
Splicing tape	72 rolls

The estimated quantities are approximations for planning purposes only, and do not represent a warranty, a guarantee, or a minimum. The actual consumption depends on variables such as machine toner settings, job-stream percent toner coverage, form characteristics, temperature, and humidity.

Also ensure that a toner-certified vacuum cleaner is available for printer operators to use when they clean the printer.

---

## IBM Supplies Worksheet

### Important Notes Concerning Supplies:

- Make sure to use the correct part numbers when you order new supplies. Using the wrong developer or toner, for example, can cause serious print quality problems and force a service call.
- Do not reuse waste toner or developer mix.
- The yields listed in Table 15 on page 177 are approximations. They are not a warranty or guarantee of minimum life; they are provided only to assist in supplies planning. Analyze your actual usage figures to determine how much of each supply item to stock.
- Toner yield is affected by several factors, including print coverage, contrast setting, form type, and environment.
- The Fine Filter processing yield is based on 4 square inches of toner coverage per foot of forms with the printer control panel Contrast switch in the center (4) position. More dense applications, such as extensive bar codes, images, solid area fill, or printing with a higher Contrast setting can expect to achieve yields lower than those achieved with the average text page.
- Your CE may install an oil pan and an absorbent pad in the pan if it is necessary for optimum printer operation. The **Oil Pan Absorbent Pad** life span varies according to the way you run the printer. In general, the more often the printer is idle, the more often you may need to replace the pad. IBM recommends that you check the absorbent pad weekly. The *InfoPrint 3000 Operator's Guide* contains instructions for checking the pad.



Contact your CE for replacement pads.

- Table 15 is a work sheet that lists IBM supplies and their part numbers. Make copies of this work sheet to use when you order supplies.

Table 15. IBM Supplies Worksheet

IBM Supply Item	Approximate Forms Processed (In Feet)	Part Number	Minimum Order Quantity	Quantity Needed
Toner cartridge	30 000 to 72 000 per cartridge <sup>1</sup>	1402828	1 carton (6 toner cartridges and 3 toner collector bags per carton)	_____
Developer Mix	850 000 per bottle	1402829	1 carton (2 bottles per carton)	_____
Fuser Oil: 1-kilogram (2.2-lb) bottle	800 000 per bottle	1372463	1 carton (1 bottle per carton)	_____
Oiler Belt	1 200 000 per belt	1402827	1 carton (1 belt per carton)	_____
Oil Pan Absorbent Pad	See note above	Contact Service Representative	1 pad (1 pad per pack)	_____
Fine Filter	1 200 000 per filter	1402826	1 carton (1 filter per carton)	_____
Splicing Tape	45 feet of tape per roll	4165880	1 carton (72 rolls per carton)	_____

<sup>1</sup> Yield depends on the contrast setting, print coverage form type, and environment.

## Ordering Supplies

You can order supplies directly from IBM or from your Lexmark representative. Your IBM representative can assist you in the procedure for placing your first order of supplies.

## Maintenance Supply Items

In the U.S.A., Latin America, and EMEA, the IBM Monthly Maintenance Charge includes the fuser oil, oiler belt, and fine filter. Approximately a 90-day stock of these items are supplied with each printer.

In the U.S.A., you can order these maintenance items by calling 1-800-793-5888 if you have an IBM Maintenance Contract.

## Customer-Replaceable Supply Items

You have these options for ordering supplies:

- You can purchase toner, developer, and other supplies through Lexmark. You can contact Lexmark at 1-800-438-2468 or through any Lexmark International authorized supply dealer.
- You can fax a completed order to Lexmark at 1-800-522-3422.

## Warranty Returns

If the supplies you receive are defective, return them to the place of purchase during the warranty period for a free replacement.

Include the following with the supplies you are returning:

- A copy of your invoice
- A description of the problem
- Print-quality samples
- An estimate of the amount of printing already done with that supply

This information applies only to supplies purchased in the U.S.A. In other countries, contact your point of purchase for returns information.

---

## Storing Supplies

Store printer supplies in the printer operating environment for at least one day before using them. At other times, you can store supplies in an environment that does not exceed the following requirements:

**Temperature**

–25° to 40°C (–13° to 104°F)

**Relative Humidity**

5% to 90%

Forms have different storage requirements. Store forms in an area where temperature and humidity are similar to the environment in which they will be used. If forms do not adapt to moisture changes, wrinkles and voids can occur during printing.

Avoid areas of extreme heat or humidity. Extended exposure to these extremes can damage the materials permanently. Relative humidity levels above 65% may reduce print quality.

---

## Adding Fuser Oil

### Attention!

You may leave printer power on while you perform this task, but the printer should not be printing.

Using the wrong fuser oil can cause print quality problems. See Table 15 on page 177 for the correct part number.

Do this task when you see the following message:

ADD FUSER OIL

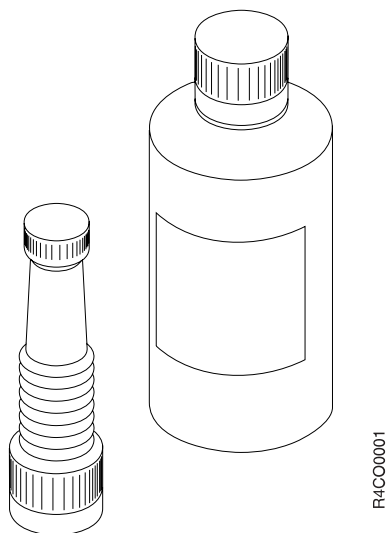

You need the following items when you add fuser oil:

- Fuser oil bottle
- Plastic spout (which is packaged with the oil)
- Paper towels.

**Note:** You do not have to replace fuser oil the first time you see the ADD FUSER OIL message. To bypass the message, **SELECT** the **Ready** pushbutton on the main Display Touch Screen.

The ADD FUSER OIL message reappears each time end-of-forms is reached, or every 4 000 feet of forms thereafter. When 50 000 additional feet of forms have been processed since the message originally appeared, you *must* add fuser oil before you can return the printer to Ready status.

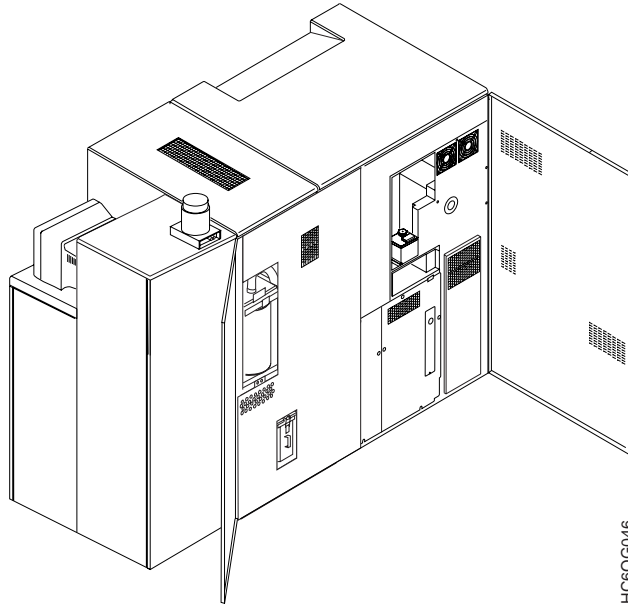

HC6G046



**CAUTION:**

<75> When adding fuser oil:

Avoid contact with eyes.  
Wash hands with soap and water after use.  
Flush eyes thoroughly in case of accidental contact.  
Keep sealed to reduce possibility of leakage.  
Wipe up spillage completely to prevent slipping.

CAUT0105

1. Open the rear center and rear right covers of the printer.
2. Remove the cap from the oil reservoir. Put the cap in a safe place.
3. Locate a bottle of fuser oil and a plastic spout. (Every new package should contain a bottle of fuser oil and a plastic spout.)
4. Ensure that the spout is clean.
5. Remove the bottle lid and the inner seal.
6. Screw the spout onto the bottle of fuser oil.
7. Bend the spout and carefully place it into the oil reservoir opening.

**Operator Tip**

When you add fuser oil, be careful to pour *slowly*. A filter in the reservoir restricts the flow of fuser oil.

8. Tip the fuser oil bottle to let the fuser oil drain into the oil reservoir.

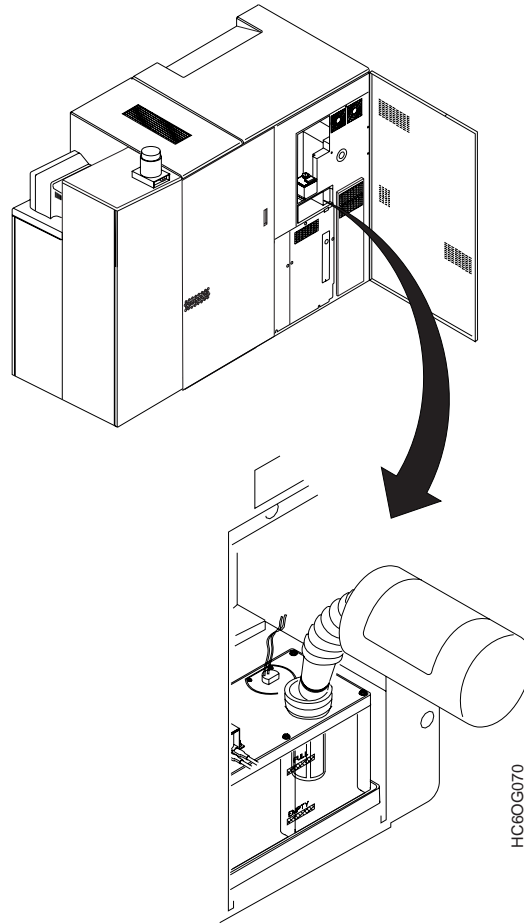

9. Remove the spout and put the lid on the bottle. If the bottle is empty, discard the bottle and the spout. If some oil remains, store the bottle and spout in a clean, dark place.
10. Ensure that the oil reservoir cap is clean.
11. Put the oil reservoir cap back in place.
12. Close the rear center and rear right covers of the printer.
13. To resume processing, **SELECT** the **Ready** pushbutton on the main Display Touch Screen.

## Changing the Toner Cartridge

### Attention!

Do *not* switch power off to the printer during this procedure.

Using the wrong toner can cause serious print quality problems; this can force a service call. See Table 15 on page 177 for the correct cartridge part number.

Do this task when you see this message:

ADD TONER 0786

You need the following items when you add toner:

- One cartridge of toner
- Cloth or paper towels.

To add toner, do the following:

1. Open the front right cover of the printer.

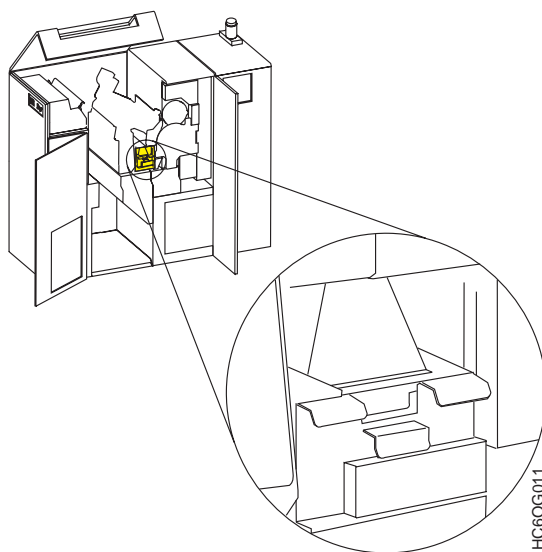

### Operator Tips

- Working with toner can be messy. You may want to spread papers on the floor under the developer inlet to catch spills.
- If you get toner on your hands, gently brush or blow it off, and avoid touching your eyes or mouth.
- If you get toner on your clothes, gently brush or blow it off. If that does not remove all of the toner, wash the clothes with *cold* water. Hot water or hot-process dry cleaning will fuse the toner to the fabric.

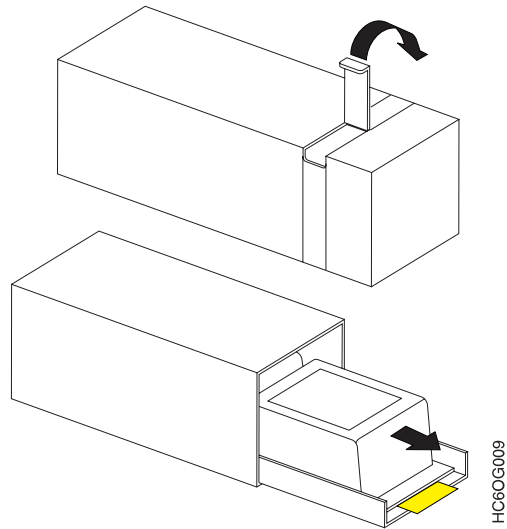

2. Open a new toner carton. Remove the carton lid, the new toner cartridge, and the cardboard tray. Save the carton lid for later use in step 12 on page 185.
3. Set the new toner cartridge aside.
4. Tap the cartridge to loosen any toner still in the cartridge.

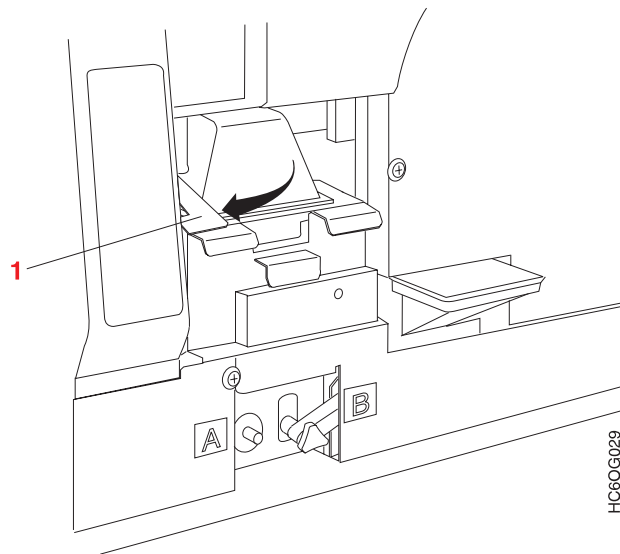

5. Open the latch (1) in front of the toner cartridge.

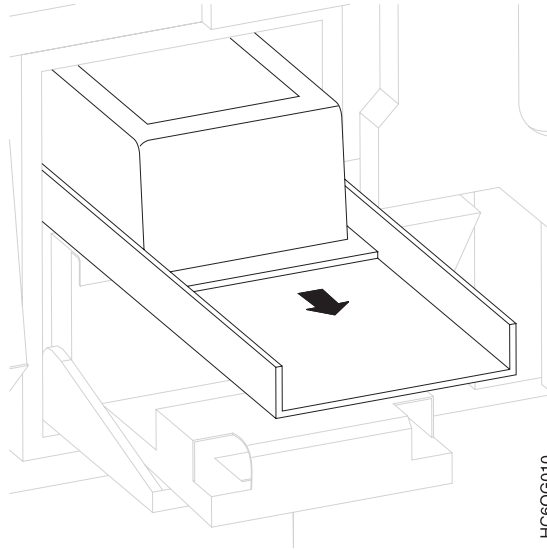

6. Line up the cardboard tray against the front edge of the toner hopper.
7. Pull the old cartridge out onto the cardboard tray *carefully* to prevent toner from spilling.
8. Place the old cartridge and cardboard tray into the carton. Set aside for disposal.

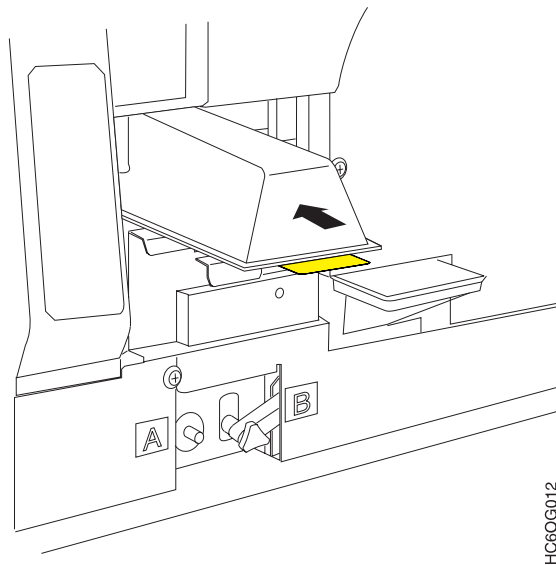

9. Insert the new toner cartridge, with the tab of the seal facing you, into the hopper.
10. Fold the tab down.



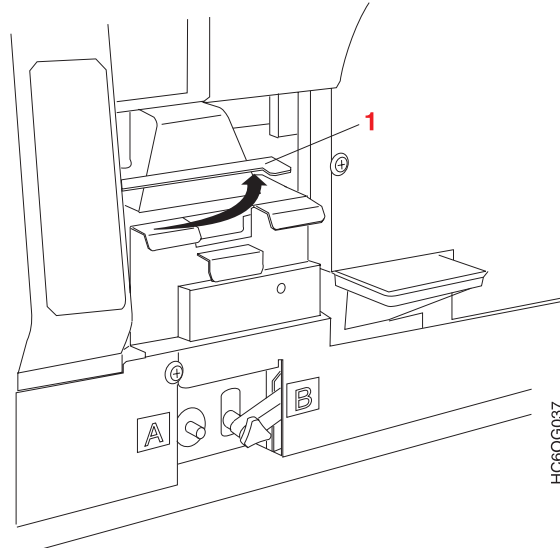

HC6OG037

11. Close the toner cartridge latch (1).
12. Place the carton lid on the lower lip of the toner hopper with the edge of the carton lid under the upper lips of the toner hopper.
13. Remove the cartridge seal from the toner cartridge by firmly pulling on the tab and rolling it under the seal until the seal is completely removed. Place the rolled seal in the carton lid.

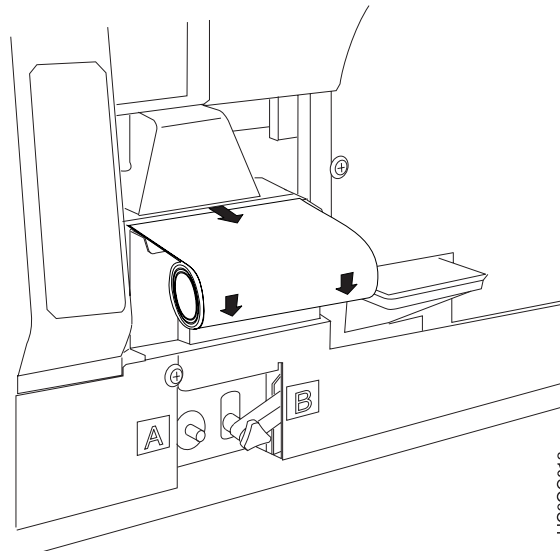

HC6OG013

14. Remove the carton lid from the toner hopper. Discard the carton lid, the cartridge seal, and the carton with the used toner cartridge.
15. Clean any spilled toner.
16. Go to “Changing the Toner Collector” on page 188 to change the toner collector.

## Checking the Toner Collector

**Attention!**

You must do this task *immediately*.

Do *not* switch power off to the printer during this procedure.

Do this task when you see the following message:

CHECK TONER COLLECTOR 0787

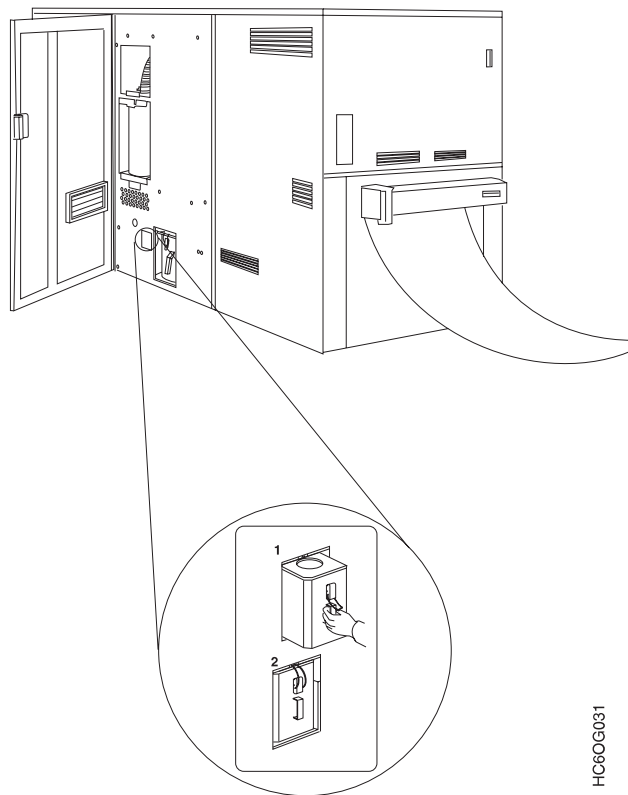

HC60G031

1. From the rear of the printer, open the rear center cover.
2. Ensure that the toner collector is pushed firmly to the rear of the toner-collector recess.
3. If you had just replaced the toner collector bag when this message appeared, try reinstalling the toner collector case.
4. If you have not replaced the toner collector bag, replace it now. Use care when you remove the toner collector in case it is over filled. See "Changing the Toner Collector" on page 188.

**Note:** If you remove the toner collector case *without* replacing the bag, the printer resets its counter and may cause an overflow of toner in the collector bag.

5. Ensure that the toner collector case is latched correctly.
6. Close the rear center cover of the printer.

7. To resume processing, **SELECT** the **Ready** pushbutton on the main Display Touch Screen.
8. If the CHECK TONER COLLECTOR message appears again, repeat steps 1 on page 186 through 6 on page 186. If that still does not correct the problem, contact your service representative. See "Service Call Procedure" on page 13 for instructions.

---

## Changing the Toner Collector

### Attention!

You must do this task *immediately*. You cannot delay it as you can for some other **Out of Supplies** conditions.

You may leave printer power on while you do this procedure, but the printer should not be printing.

Never reuse waste toner. Doing so severely reduces print quality and may require repair of the printer.

Do this task when you finish adding toner and the following message appears with the ADD TONER message, or when this message appears alone:

CHANGE TONER COLLECTOR 0785

You need the following items when you change the toner collector:

- New toner collector bag
- Paper towels.

### Operator Tips

- You may want to spread papers on the floor near the toner collector to catch spills.
- If you get toner on your hands, gently brush or blow it off, and avoid touching your eyes or mouth.
- If you get toner on your clothes, gently brush or blow it off. If that does not remove all of the toner, wash the clothes with *cold* water. Hot water and hot-process dry cleaning will cause the toner to fuse to the fabric.

1. Press the **Stop** pushbutton on the Display Touch Screen.

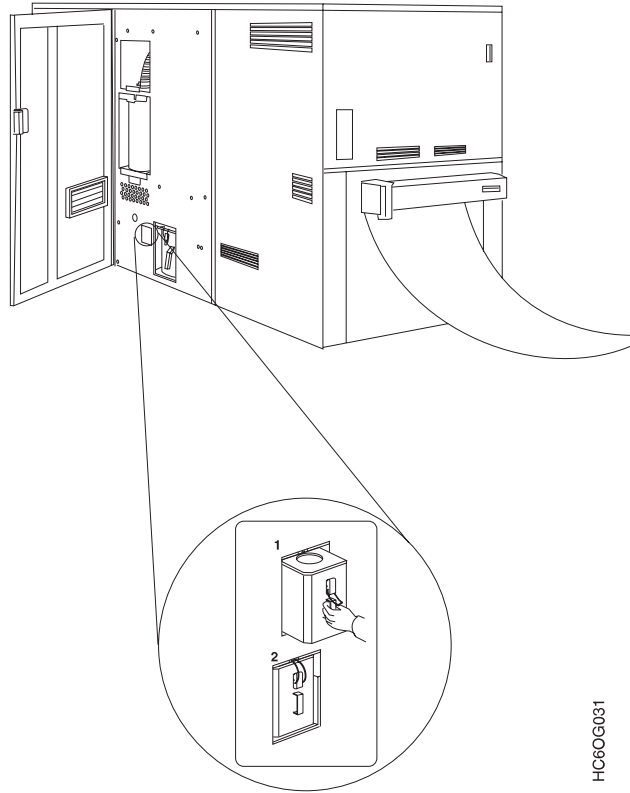

HC60G031

2. Open the rear center cover.
3. Lift the latch and remove the ring from the hook on the handle of the toner collector case.
4. Pull the toner collector case straight out.
  
5. Apply the adhesive seal that is supplied with the toner over the opening of the used toner collector bag.
6. Remove the bag from the toner collector case carefully to avoid spilling the waste toner. Discard the bag.
7. Grasp the bottom of a new toner collector bag and expand it. Insert the tabs under the lip at the top of the bag.

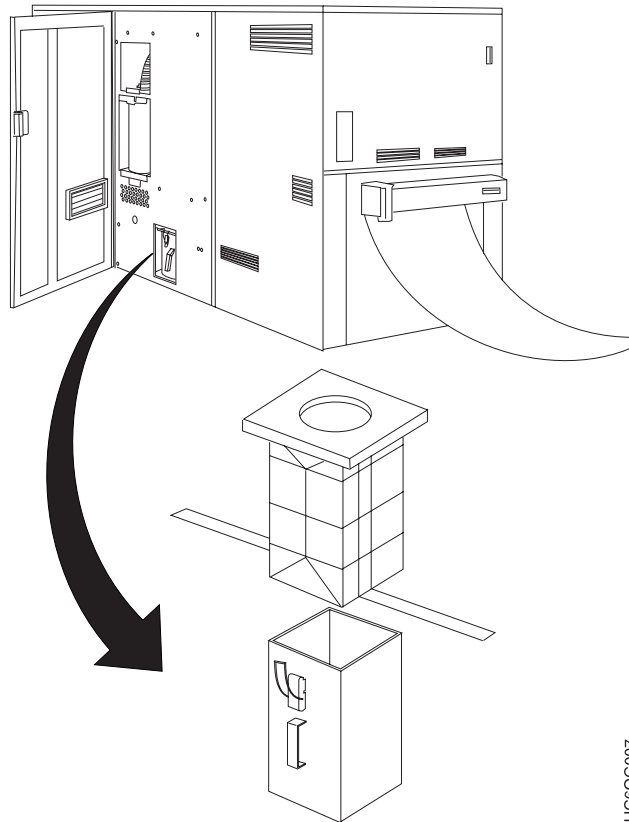

HC60G007

8. Place the new toner collector bag in the toner collector case.
9. Return the toner collector case to the printer.

**Note:** Be sure to insert the toner collector case firmly enough to depress the spring-loaded sensor tab in the rear of the cavity.

10. Attach the ring to the hook and push down the latch on the toner collector case.
11. Close the rear center cover.
12. Press **Ready** pushbutton on the Display Touch Screen to continue.

---

## Changing the Developer Mix

### Attention!

You **must** leave printer power on while you do this task, but the printer should not be printing.

Using the wrong developer mix can cause serious print quality problems; this can force a service call. See Table 15 on page 177 for the correct developer mix part number.

Do this task when you see the following message:

CHANGE DEVELOPER MIX 0788

**Note:** You do not have to replace developer mix the first time you see the CHANGE DEVELOPER MIX message. To bypass the message, **SELECT** the **Ready** pushbutton on the main Display Touch Screen.

The CHANGE DEVELOPER MIX message reappears each time end-of-forms is reached, or every 4 000 feet of forms thereafter. When 50 000 additional feet of forms have been processed since the message originally appeared, you **must** change developer mix before you can return the printer to Ready status.

### Operator Tips

- Developer mix is slippery, and working with it can be messy. You may want to spread papers on the floor under the developer drain hose and under the developer mix inlet to catch spills.
- If you get developer mix on your hands, wipe it off as soon as possible.

You need the following items when you change the developer mix:

- Developer mix
- An empty developer mix bottle
- Soft cloth or paper towels.

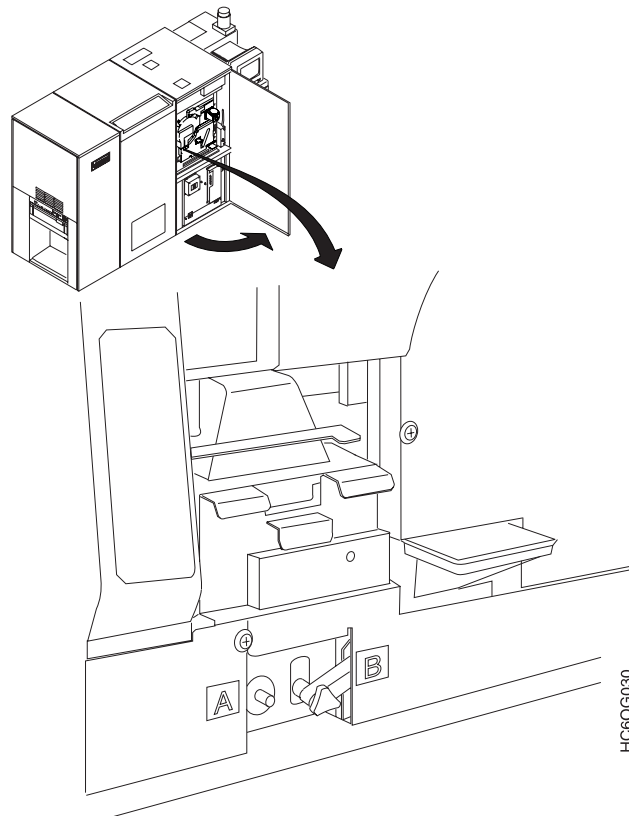

HC6G030

1. Open the front center left and right covers and the top left cover.
2. Clear the forms, if possible, from the forms input area. If you cannot remove the forms from the input area, do the following:
  - If you are using boxed fan-fold forms, slide the box of forms as far to the left (stacker end of the printer) of the forms input area as possible.
  - If you are using a preprocessing device supplying forms under the printer up into the forms input area, create enough slack in the forms supply so that you can move the forms to the far left side of the forms input area.  
Spread paper towels on top of the forms and on the floor of the forms input area.
3. Remove the *empty* developer mix bottle from its storage slot at the right of the forms input area.



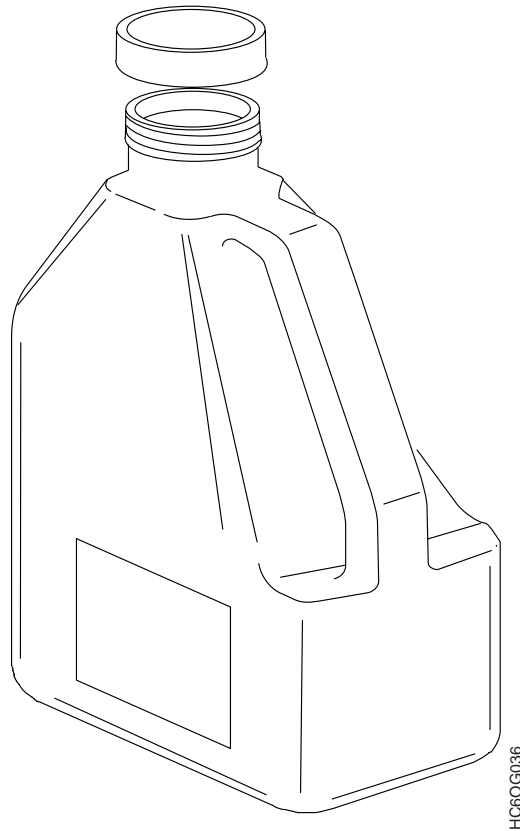

4. Remove the cap from the empty bottle. Put the bottle back in the slot, directly under the developer mix drain hose.
5. Grasp the drain hose and turn the capped end up upward (so that any developer mix in the hose from the last change does not spill). Remove the cap from the hose.

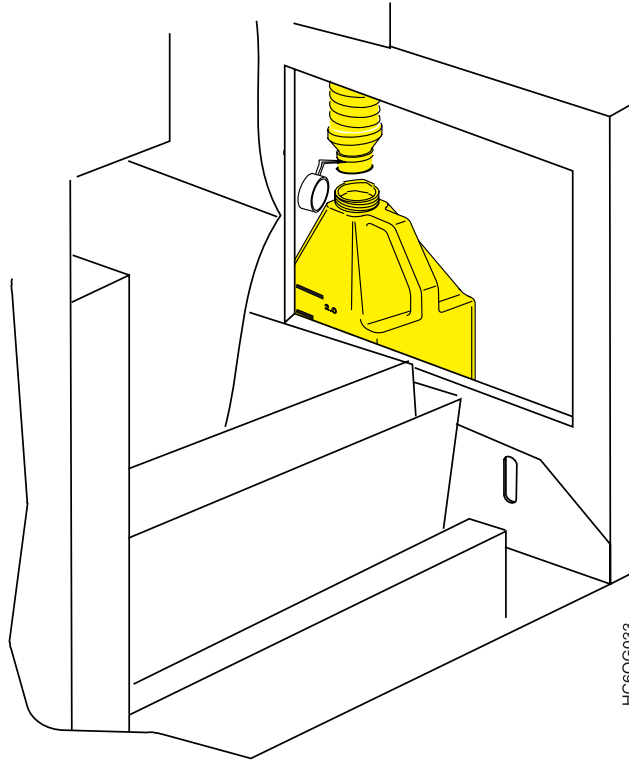

HC606033

6. Carefully insert the end of the hose into the empty developer mix bottle. Ensure that the hose is inserted securely and that no sharp bends obstruct the hose.

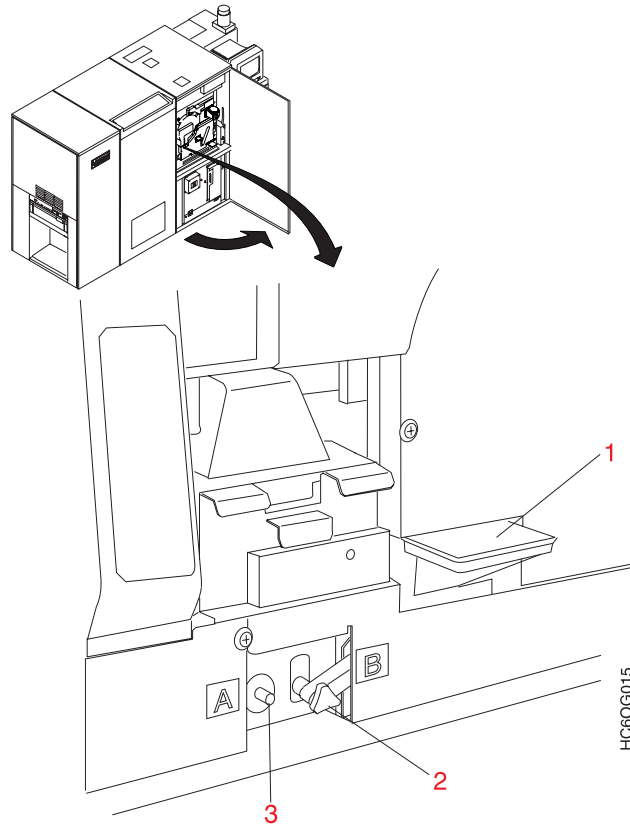

7. Locate the Developer Mix Inlet (1), the Developer Drain Lever B (2), and the Developer Run Pushbutton A (3) in the developer area.

**Important**

- a. Never open the developer drain unless the developer drain hose is inserted into an empty developer mix bottle.
- b. After you have opened and closed the developer drain, you *must* replace the developer mix. Opening the drain resets the developer mix usage timer. Resetting the timer without changing the developer mix could result in severe print quality problems that are caused by the developer mix being used beyond its normal life.

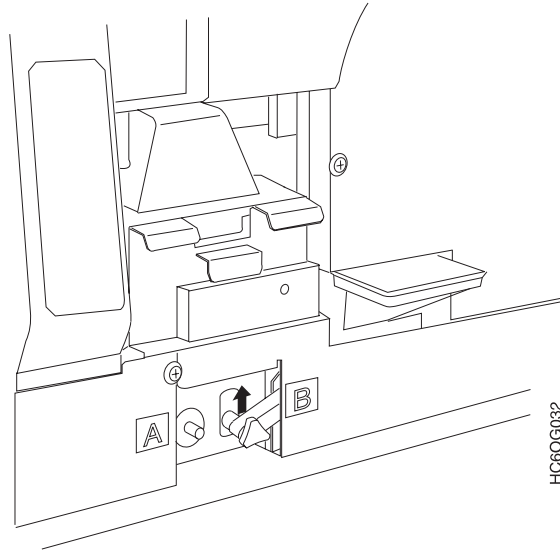

8. Open the Developer Drain Lever **B** by pulling out the lever and then lifting it upward.
9. The developer mix starts draining immediately. Hold the drain hose so that it does not come out of the empty mix bottle. Shake the hose several times while the mix is draining to ensure that no developer mix remains in the hose.

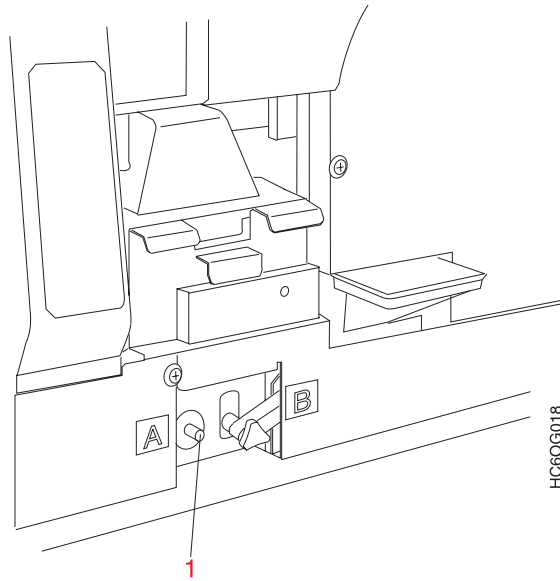

10. Press the Developer Run Pushbutton **A** (1) one time to ensure that all of the developer mix is drained. There should be about 1.8 liters of used developer mix in the bottle.

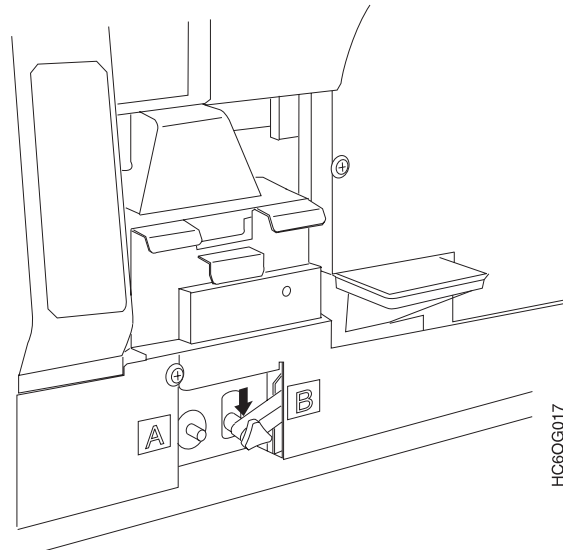

11. When the developer stops running, close the developer drain by pushing the Developer Drain Lever **B** downward and then pushing it in.
12. Once the developer mix has finished draining, ensure that no developer mix remains in the drain hose. Do this by shaking the hose vigorously while you hold the hose as vertical as possible.
13. Remove the developer drain hose from the bottle. Put the cap on the developer drain hose, and return the hose to its recessed storage area.
14. Put the cap on the bottle. Discard the bottle and its contents.

**Attention!**

To prevent print quality problems, never reuse waste developer mix. Never put anything other than new developer mix into the developer mix inlet.

15. Remove the cap from the new developer mix bottle.

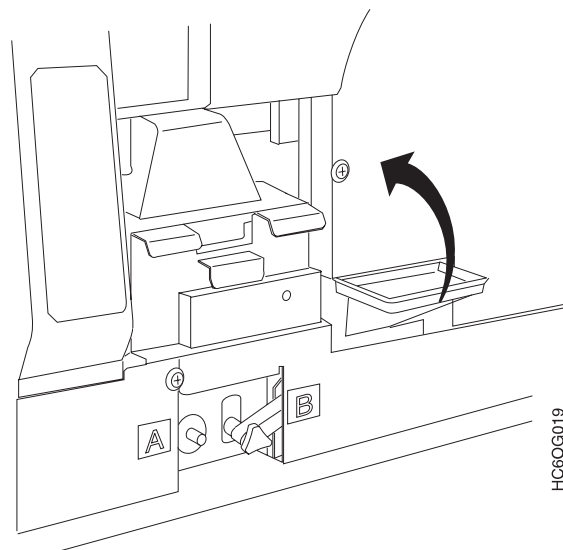

16. Remove the developer inlet cover.

17. Clean the cover to remove any excess developer mix, and put it in a safe place.

**Important**  
Ensure that the developer drain is closed.

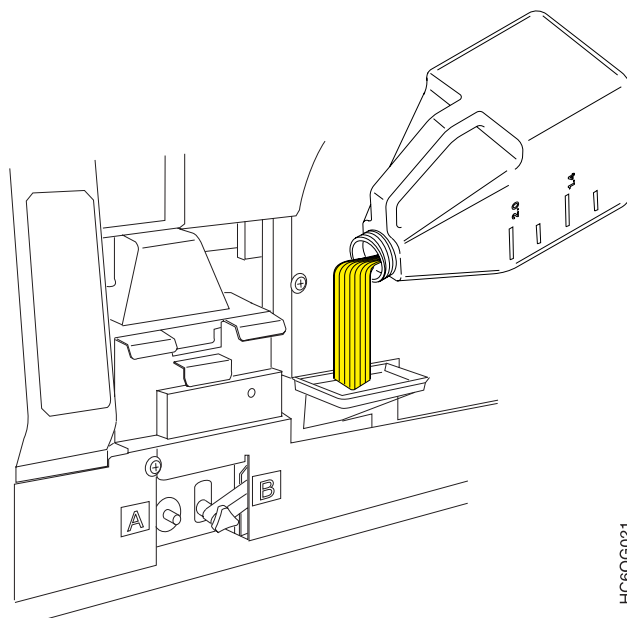

18. Press the Developer Run Pushbutton **A** and slowly pour the developer mix into the inlet.  
If the developer stops running before the new developer mix bottle is empty, press the Developer Run Pushbutton **A** again.
19. Clean the empty developer mix bottle with a cloth or paper towel to remove any excess developer mix. Store the bottle in the recess at the right of the forms input area in front of the drain hose for the next time you change developer mix.

**Operator Tip**  
If you already have several empty developer mix bottles in storage, you may discard the extra bottle.

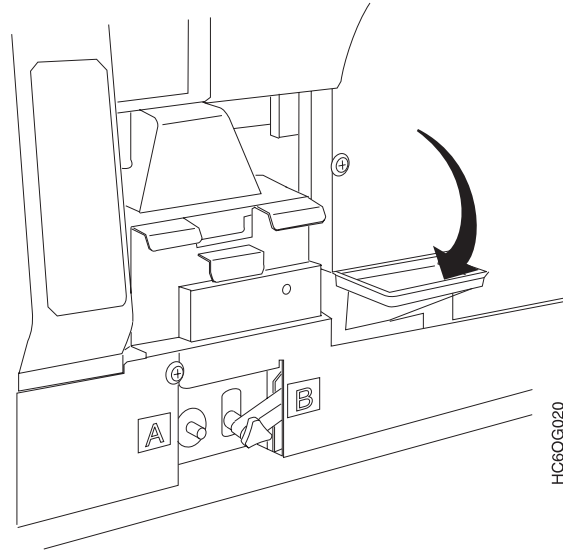

**Attention!**

Never operate the printer when the developer inlet cover is removed.

20. Put the developer inlet cover back in place.
21. Clean the developer area with a cloth or paper towel to remove any spilled developer mix.
22. Replace the forms in the forms input area so that printing may continue.
23. Close the covers of the printer.
24. To resume processing, **SELECT** the **Ready** pushbutton on the main Display Touch Screen.

---

## Checking the Fine Filter

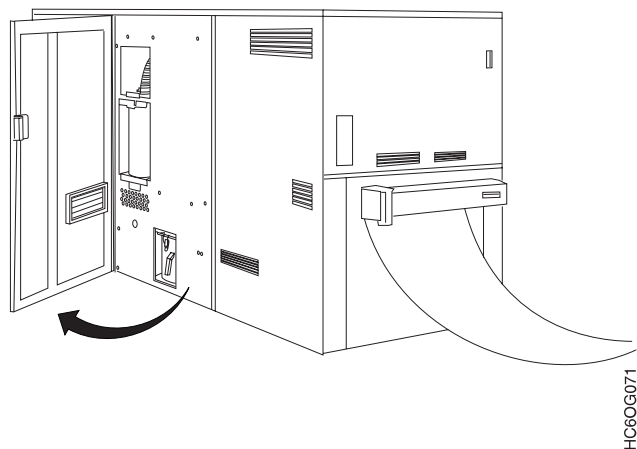

Do this task when you see the following message:

CHECK FINE FILTER 0799

**Note:** You must do this task immediately. You cannot delay it as you can with some **Out of Supplies** conditions.

1. From the rear of the printer, open the rear center cover.
2. Ensure that the filter container is upright in the recessed filter area.
3. Ensure that the filter cover is firmly latched in place.
4. Ensure that the filter hose is attached to the filter cover.
5. Close the rear center cover of the printer.
6. To resume processing, **SELECT** the **Ready** pushbutton on the main Display Touch Screen.
7. If the CHECK FINE FILTER message appears again, repeat steps 2 through 6. If that still does not correct the problem, contact your service representative. See "Service Call Procedure" on page 13 for instructions.



## Changing the Fine Filter

**Attention!**

You may leave printer power on while you perform this task, but the printer should not be printing.

To clear this action message, the printer power *must* be on while you replace the fine filter.

Do this task when you see the following message:

CHANGE FINE FILTER 0791

**Note:** You do not have to replace the fine filter the first time you see the CHANGE FINE FILTER message. To bypass the message, **SELECT** the **Ready** pushbutton on the main Display Touch Screen.

The CHANGE FINE FILTER message reappears each time end-of-forms is reached, an error condition occurs, or every 4 000 feet of forms thereafter. When 100 000 additional feet of forms have been processed since the message originally appeared, you *must* change the fine filter before you can return the printer to Ready status.

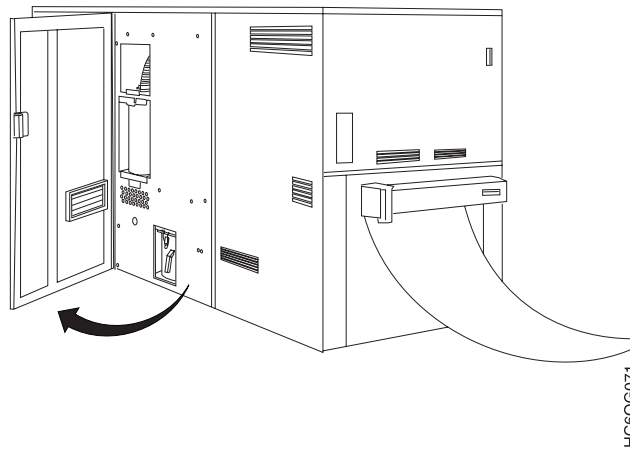

1. Locate a new fine filter.
2. From the rear of the printer, open the rear center cover.

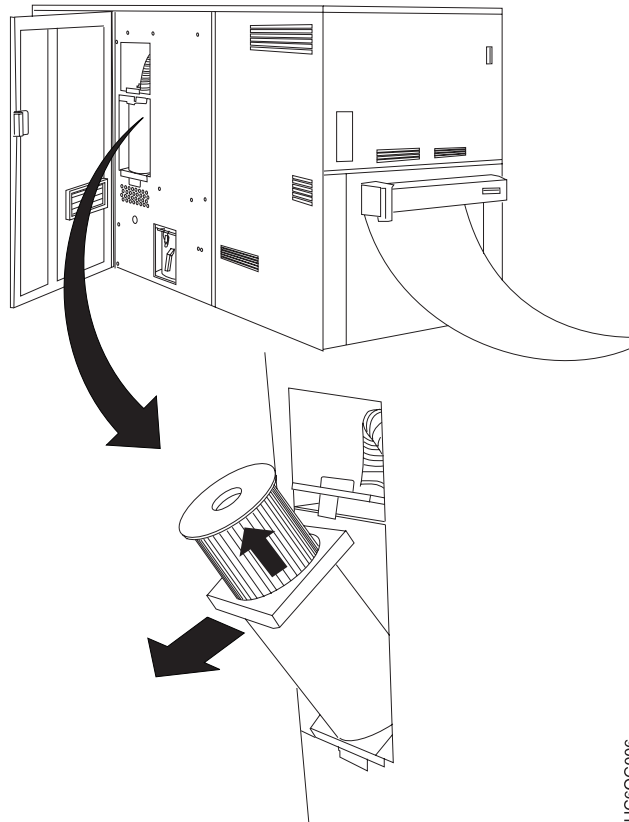

HC60G006

3. Locate the latch on the filter cover and pull the latch up to open the filter housing.
4. Pull the filter housing out until it is tilting toward you about 30°.
5. Remove the plastic bag from the new fine filter and place the fine filter on the floor.
6. Slowly pull the old fine filter out of the filter housing and place it in the plastic bag from the new fine filter.
7. Discard the used fine filter.
8. Wipe the filter housing with a soft cloth to remove any debris.

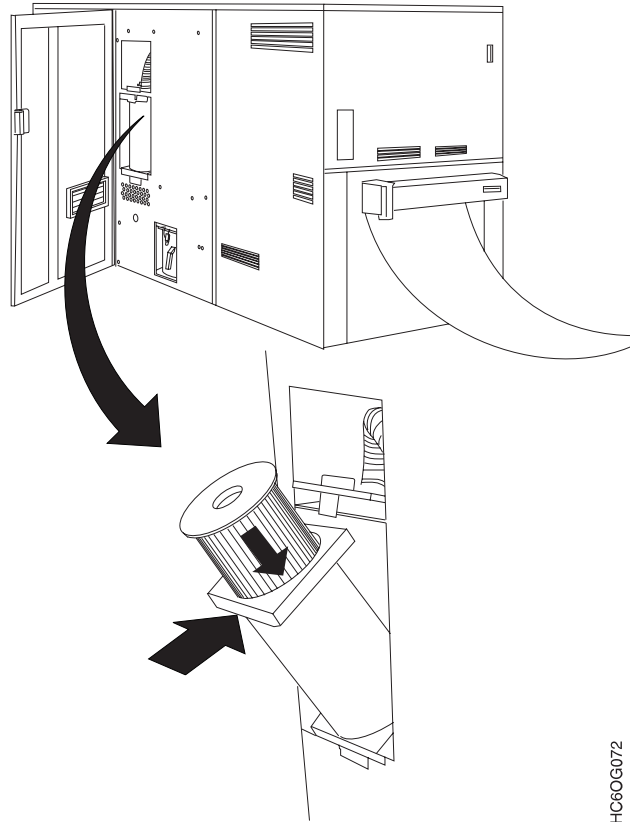

HC60G072

9. Put the fine filter in the filter housing. Ensure that the fine filter is completely in the filter housing.
10. Return the fine filter housing to its upright position in the recess.
11. Lower the filter cover and secure the latch.
12. Close the right rear cover of the printer.
13. To resume processing, **SELECT** the **Ready** pushbutton on the Display Touch Screen.
14. If the CHECK FINE FILTER message appears, the fine filter may not be pushed all the way into the filter housing. Adjust the fine filter, then repeat step 13. If that does not correct the problem, contact your service representative. See "Service Call Procedure" on page 13 for instructions.

---

## Changing the Oiler Belt

### Attention!

You may leave printer power on while you perform this task, but the printer should not be printing.

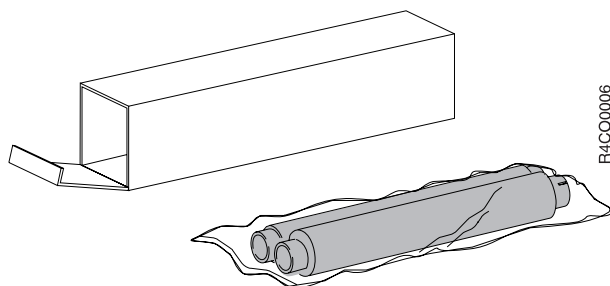

Do this task when you see the following message:

CHANGE  
OILER BELT 0793

**Note:** You do not have to replace the oiler belt the first time you see the CHANGE OILER BELT message. To bypass the message, **SELECT** the **Ready** pushbutton on the main Display Touch Screen. The message reappears each time end-of-forms is reached or every 4 000 feet of forms thereafter. When 10 000 additional feet of forms have been processed since the message originally appeared, you *must* change the oiler belt before you can return the printer to Ready status.

You need the following items when you change the oiler belt:

- New oiler belt
- Paper towels.

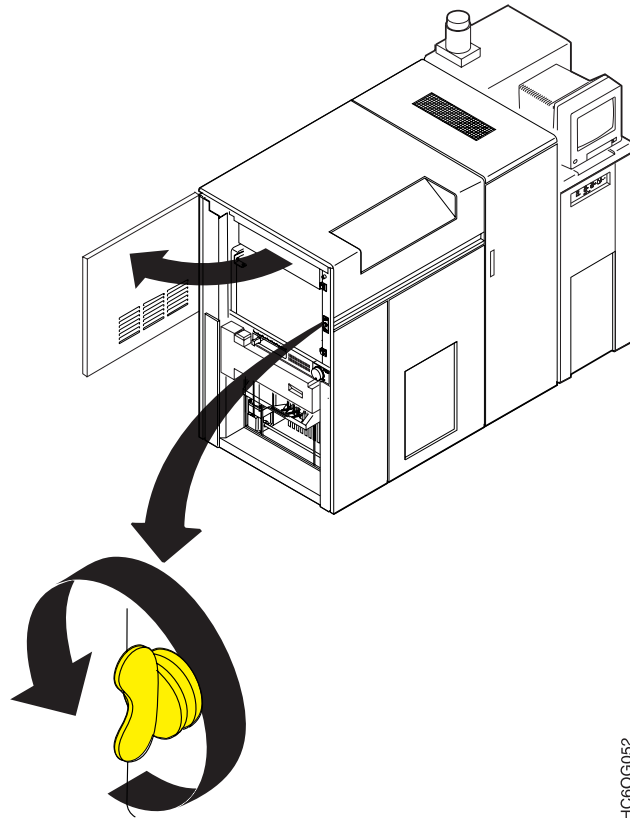

HC6OG062



**CAUTION:**

<70> The oiler belt, oiler wick roll, and their environments are *high-temperature* areas. Be very careful when working in these areas.

1. Open the stacker end cover.

**Note:** When the oiler-belt gate is opened, the fuser begins to cool down immediately, and the message changes to OILER GATE OPEN.

2. Turn the wing nut *counterclockwise* to release the oiler-belt gate.
3. Place several layers of absorbent material, such as paper towels, on the floor beneath the oiler-belt gate.

CAUT0100

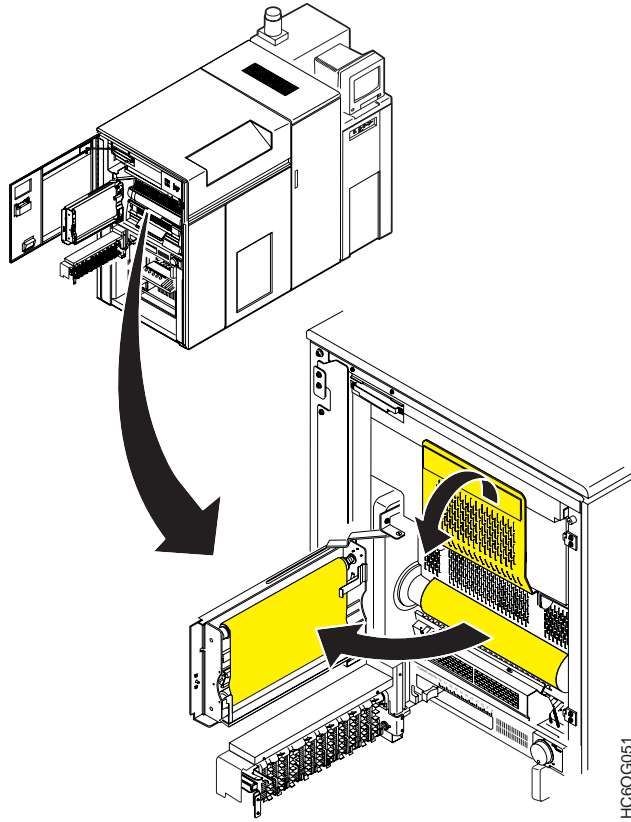

HC60G051

4. Open the oiler-belt gate.
5. Allow the printer to cool for at least **30 minutes**.
6. Lower the hot roll shield.

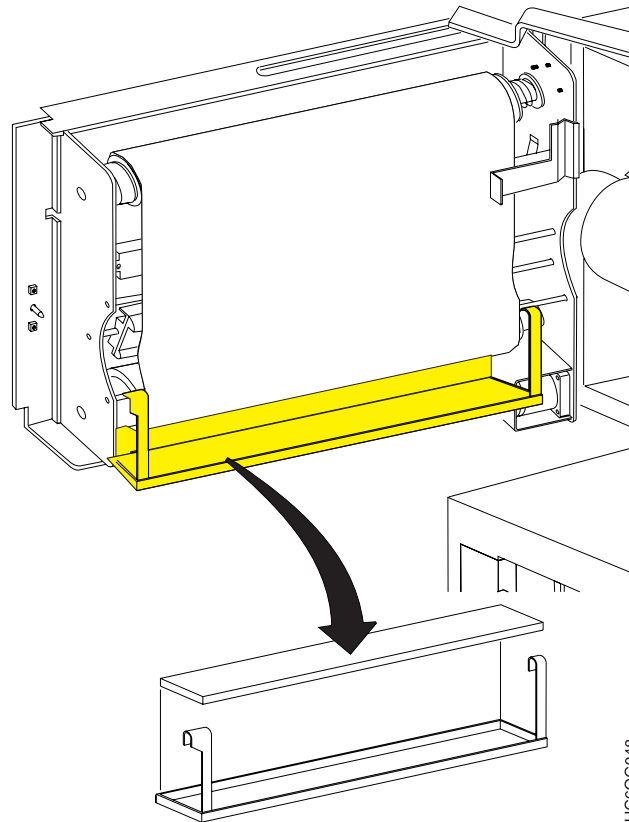

7. If you are changing the oiler belt and the oil pan that is shown above is present, do the following. Otherwise, go to step 8 on page 208.
  - a. Remove the oil pan by lifting the pan until the hooked portion is disengaged from the lower oiler belt support shaft.
  - b. Check to see if the absorbent pad is saturated with oil. If the pad is saturated, continue with the next step. If it is not saturated, go to step 8 on page 208.
  - c. Remove the new absorbent pad from the plastic shipping bag.
  - d. Remove the saturated absorbent pad from the oil pan.
  - e. Place the saturated pad in the plastic shipping bag and discard the bag in an approved waste container.
  - f. Install the new absorbent pad in the oil pan.

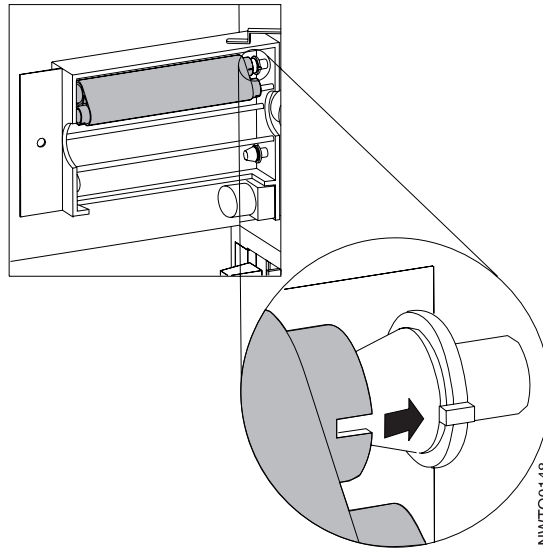

8. Grasp both ends of the upper oiler-belt roll, and move it to the right against the spring.

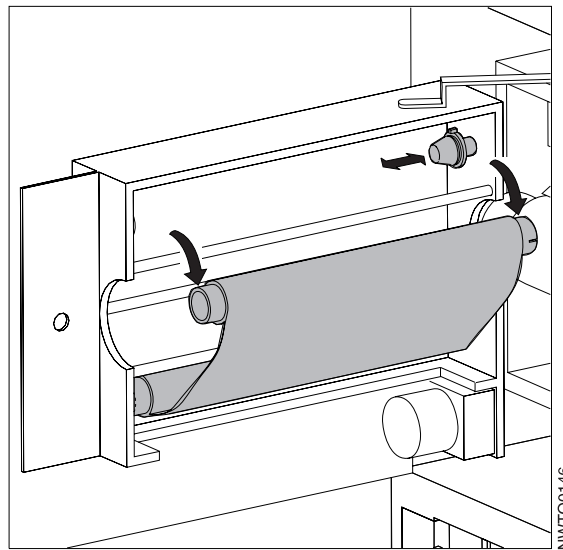

9. Pull out the upper oiler-belt roll, left end first.



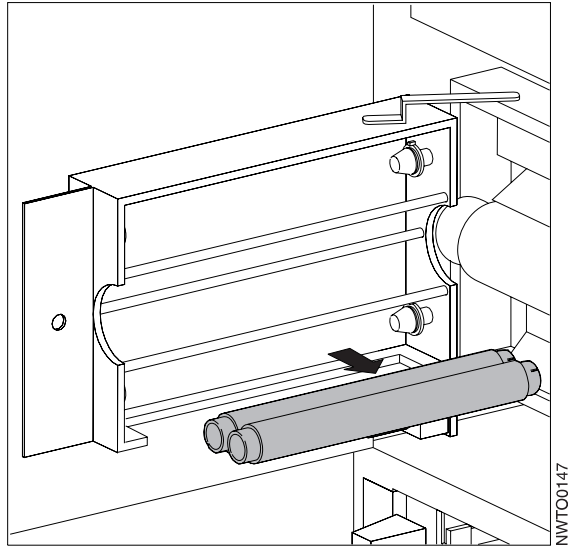

10. Roll the upper roll down against the lower roll.
11. Holding both rolls, press the lower oiler-belt roll to the right against the spring.
12. Remove the lower oiler-belt roll by removing the left end first.
13. Place the old oiler belt on several thicknesses of absorbent material, such as paper towels.
14. Remove the new oiler belt from its carton, saving the plastic bag for the old oiler belt.

**Operator Tip**

The oiler-belt roll with the most material is the *upper* roll. The notched end of the roll is the *right* side (nearest the printer).

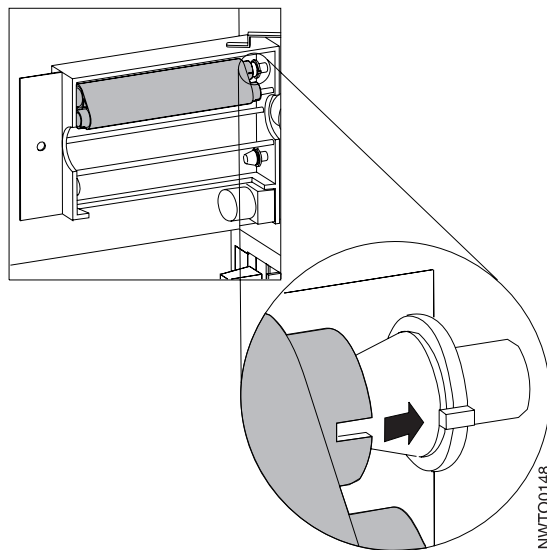

**Important**

When you install the oiler-belt rolls, you *must* line up the notches in the rolls with the tabs on the sprocket. If you do not do this, the oiler belt does not advance correctly. This causes reduced print quality.

15. While you hold the upper (larger) roll against the lower roll, do the following:
  - a. Place the right end of the upper roll on the sprocket, lining up the notches in the roll to the tabs on the sprocket. Press the upper roll to the right, against the spring.
  - b. Place the left end of the upper roll on the sprocket, and let the right spring-loaded sprocket hold the roll in place.
16. Working with the lower roll, repeat step 15.

**Note:** The oiler belt must be under the tab (1).

17. Rotate the upper oiler-belt roll to remove slack in the belt.

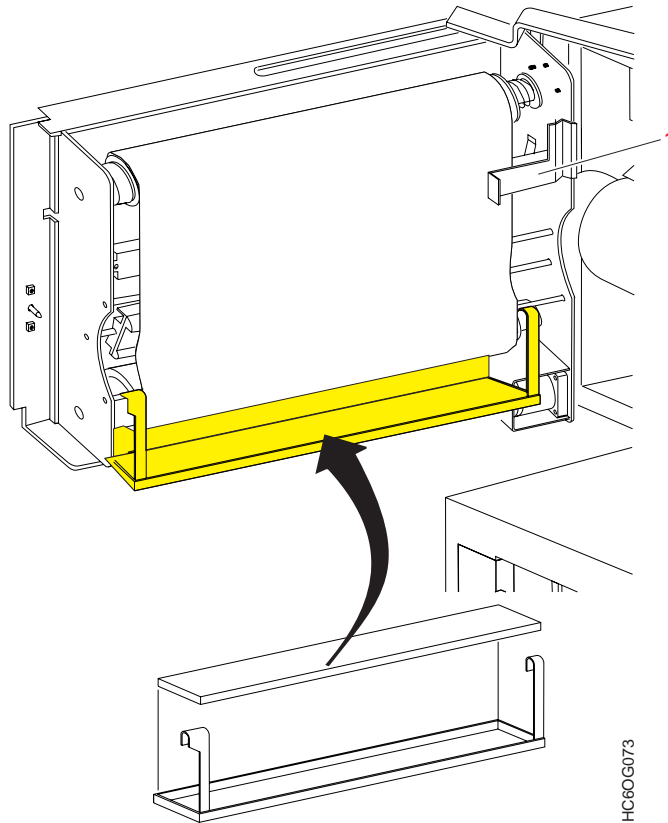

18. If you are changing the oiler belt and you removed the oil pan that is shown above in step 7 on page 207, reinstall the pan now.
19. Raise the hot roll shield.
20. Close the oiler-belt gate.
21. Turn the wing nut *clockwise* to latch the gate. Ensure that the gate is firmly latched.
22. Close the stacker end cover.
23. The message may change to WARMING UP or PLEASE STAND BY.

24. To resume processing, **SELECT** the **Ready** pushbutton on the main Display Touch Screen.
25. Place the old oiler belt inside the plastic bag and discard it.

## Checking the Absorbent Pad in the Oil Pan

Not every printer has an oil pan and absorbent pad. Your CE may install these if they are necessary for optimum printer operation.

### Attention!

You may leave printer power on while you perform this task, but the printer should not be printing.

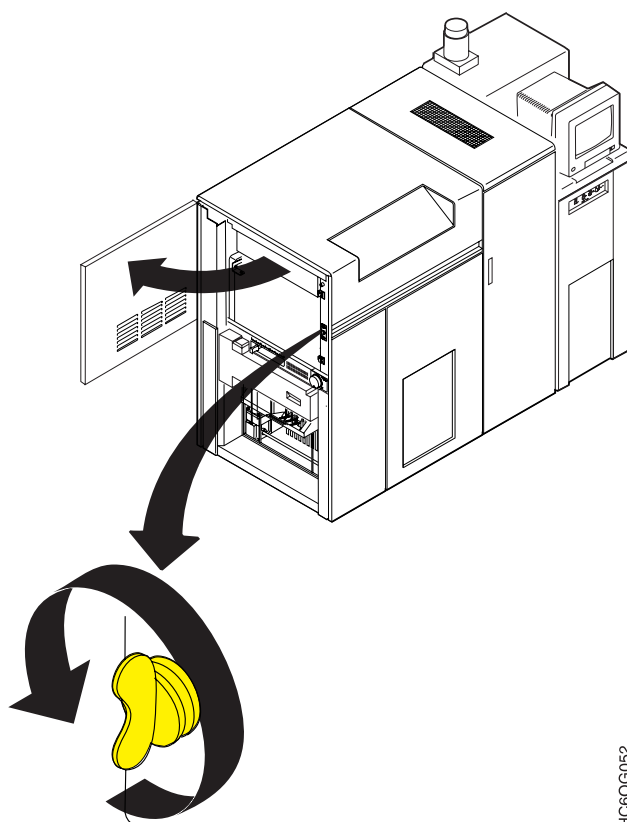

HC60G032



### CAUTION:

<70> The oiler belt, oiler wick roll, and their environments are *high-temperature* areas. Be very careful when working in these areas.

1. Open the stacker end cover.

**Note:** When the oiler belt-gate is opened, the fuser begins to cool down immediately, and the message changes to OILER GATE OPEN.

2. Turn the wing nut *counterclockwise* to release the oiler-belt gate.
3. Place several layers of absorbent material, such as paper towels on the floor beneath the oiler-belt gate.

CAUT0100

4. Open the oiler-belt gate.

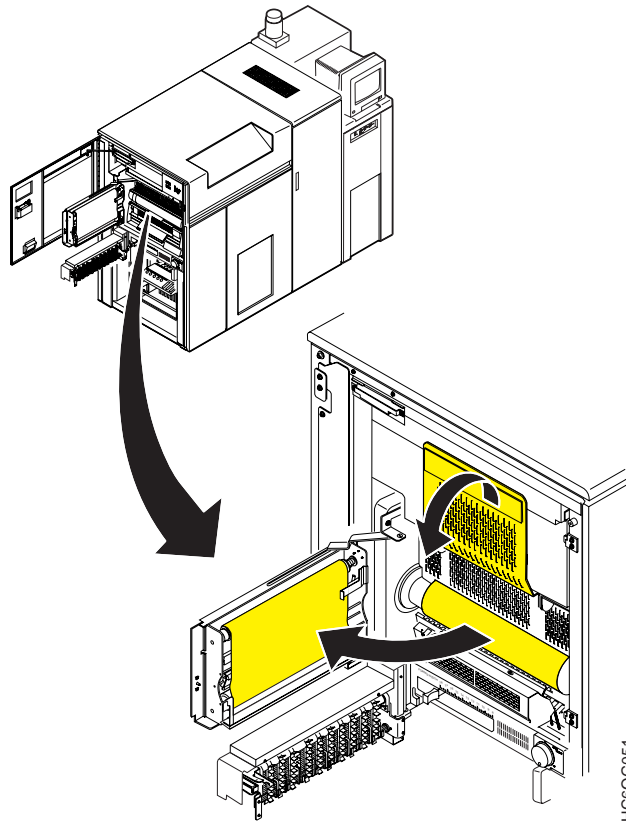

5. Check to see if the absorbent pad is saturated with oil. If the pad is saturated, continue with step 6. If it is not saturated, go to step 15 on page 215.
6. Allow the printer to cool for at least **30 minutes**.
7. Lower the hot roll shield.

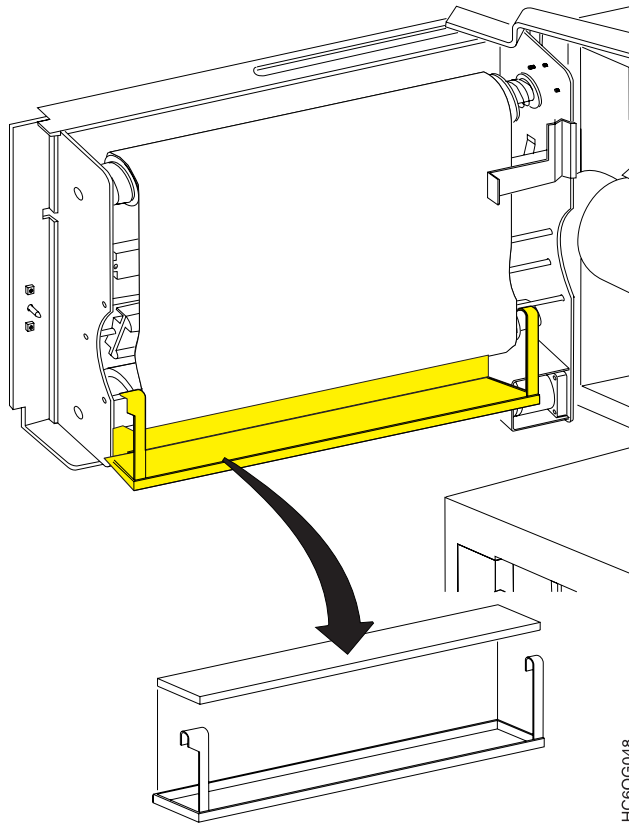

8. Remove the oil pan by lifting the pan until the hooked portion of the pan is disengaged from the lower oiler-belt support shaft.
9. Remove the new absorbent pad from the plastic shipping bag.
10. Remove the saturated absorbent pad from the oil pan.
11. Place the saturated pad in the plastic shipping bag and discard the bag in an approved waste container.
12. Install the new absorbent pad in the oil pan.

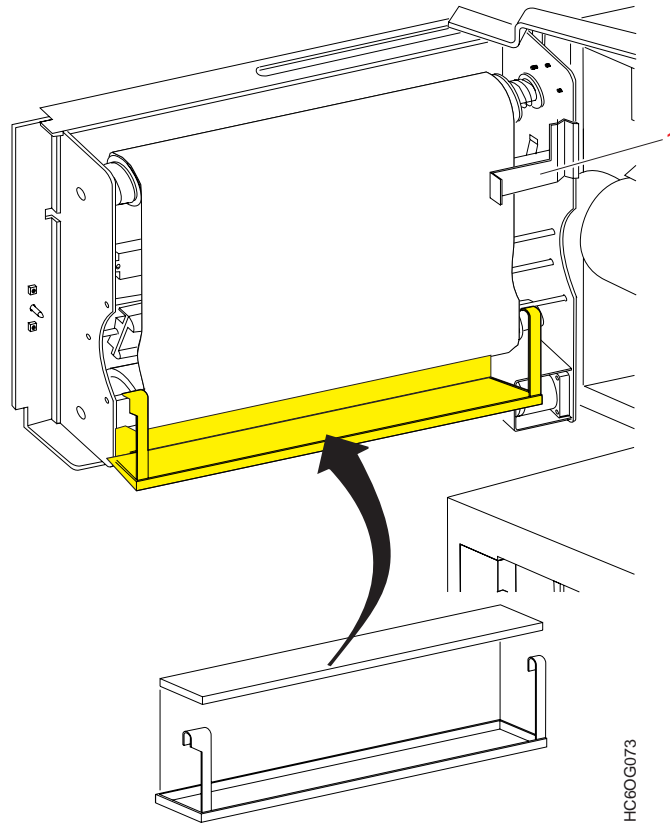

13. Install the oil pan onto the lower oiler-belt support shaft.
14. Raise the hot roll shield.
15. Close the oiler-belt gate.
16. Turn the wing nut *clockwise* to latch the gate. Ensure that the gate is firmly latched.
17. Close the stacker end cover.
18. The message may change to WARMING UP or PLEASE STAND BY.
19. To resume processing, **SELECT** the **Ready** pushbutton on the main Display Touch Screen.





---

## Chapter 8. Configuring the System

Changing the Language of Messages . . . . .	218	Configuring Preprocessing/Postprocessing	
Configuring the Printer . . . . .	219	Devices/Interfaces . . . . .	241
Printer Configuration Information . . . . .	220	Pre/Postprocessor Configuration Values . . . . .	243
Configuring the Host Attachments . . . . .	229	Configuring Remote Access . . . . .	245
Parallel Channel Configuration Information	232	Defining Forms . . . . .	247
ESCON Channel Configuration Information	234	Duplex Configuration Worksheet . . . . .	251
Token Ring TCP/IP Attachment Information	235	Simplex Configuration Worksheet . . . . .	258
Ethernet TCP/IP Attachment Information. . . . .	237	Form Identification Worksheets . . . . .	263
FDDI TCP/IP Attachment Information. . . . .	239	Form Identification Worksheet . . . . .	264

### **Important**

This chapter describes how to update the printer configuration. It assumes that the person changing the configuration is familiar with the various settings, and understands the impact that changes may have on the system.

## Changing the Language of Messages

This procedure lets you change the language that is used for all text within the Display Touch Screen windows.

1. **SELECT** the **Options** pull-down menu on the main Display Touch Screen window.
2. **SELECT** the **Change Language** procedure. You see the **Change Language** window, which lists the languages you can select. Each language has its native spelling and accent marks.

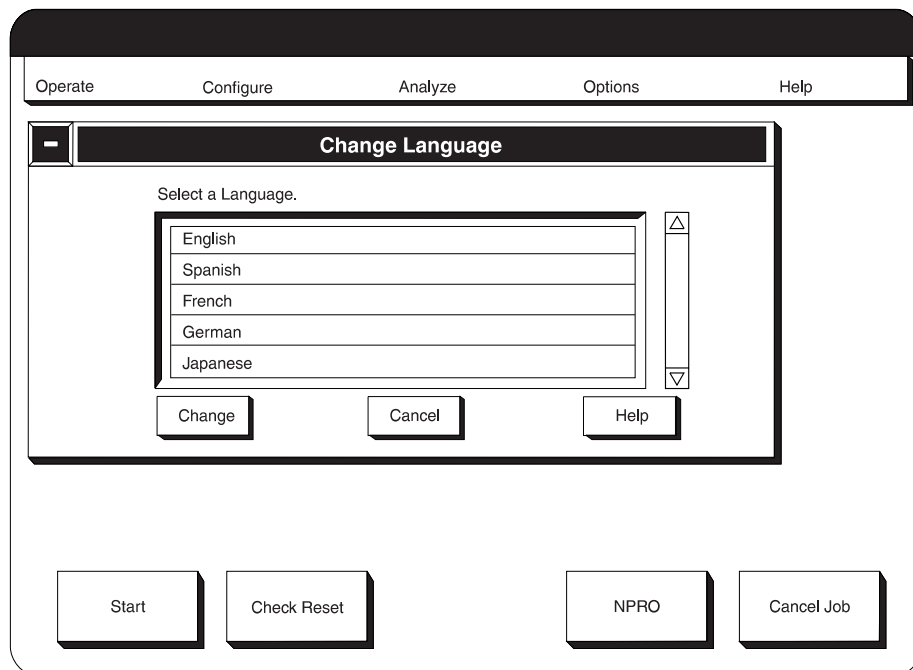

3. **SELECT** a new language from the list. In dual simplex mode, the language applies to the Display Touch Screen windows for both printers.
4. **SELECT** the **Change** pushbutton. You see a **Language Change Warning** prompting window. Some language changes automatically shutdown and restart the system.
5. **SELECT** the **OK** pushbutton to change the language.

## Configuring the Printer

This procedure lets you view, update, or print a copy of the printer configuration.

**Note:** The printer can have multiple sets of configuration data: one for each mode in which the printer can operate. To update a configuration for a particular mode, the printer must be running in that mode.

1. Before you *print* the printer configuration, ensure that all attachments are disabled. See “Enabling and Disabling Attachments” on page 63 for more information. You do not need to disable attachments if you are viewing or changing the configuration.
2. To access the configuration settings, do one of the following:
  - In simplex or duplex mode, **SELECT** the **Configure** pull-down menu.
  - In dual simplex mode, **SELECT** the **Configure** pull-down menu on the Display Touch Screen window of the printer with which you want to work.
3. **SELECT** the **Configure Printer** procedure. The **Configure Printer** window appears. Use the scroll bar to scroll through the list of configuration items. For information about configuration items, see Table 16 on page 221 or **SELECT** the **Help** pushbutton on the **Configure Printer** window.

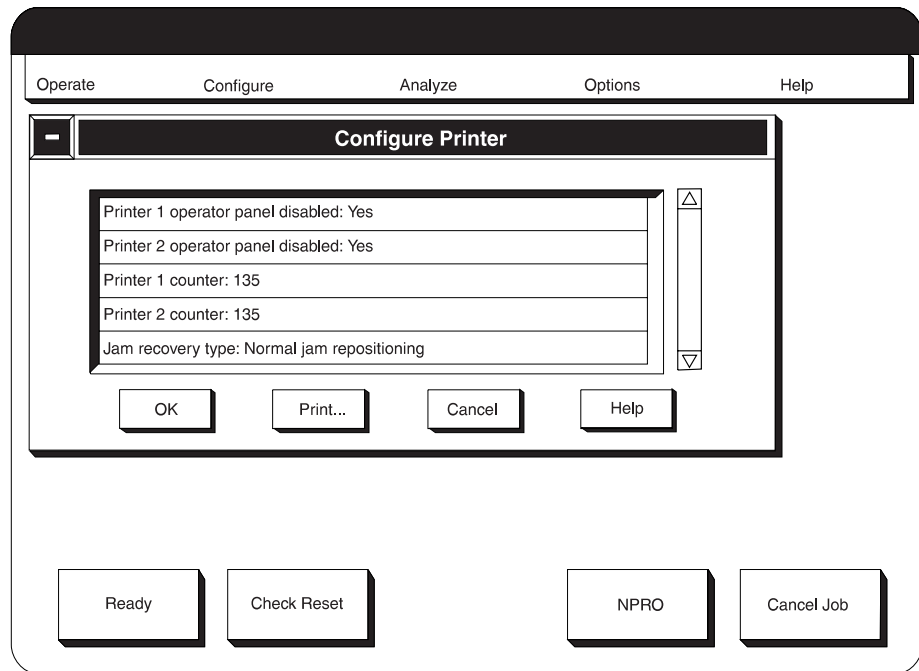

Figure 34. Configure Printer Window

4. To print a copy of the configuration, do the following:
  - a. **SELECT** the **Print...** pushbutton. You see the **Print Configuration** window.
  - b. To change the number of copies you print, do the following:
    - 1) **SELECT** the **How Many?** field.
    - 2) Type the number of copies you want to print.
    - 3) **SELECT** the **OK** pushbutton.

**Note:** The printer does not collate multiple copies. This has to be done by hand.

- c. **SELECT** the **Print** pushbutton on the **Print Configuration** window.

**Important**

The configuration data is always printed in U.S. English.

5. To change an item:
  - a. **SELECT** it from the list. You see either a pop-up window or a keypad window.
  - b. **SELECT** the value you want from the pop-up window, or enter data on the keypad window. Then **SELECT** the **OK** pushbutton.  
Repeat this step for as many items as you want to change.

**Note:** If you are changing **Printer Mode** or **Printhead Resolution**, any other configuration items you may be changing will change *only* for the mode you are switching *from*. The mode you are switching *to* will not have any changed configuration items.

- c. When you have made all the changes, **SELECT** the **OK** pushbutton. You see the **Restart** prompting window.
- d. If you have other configuration changes to make, you can make them before you restart the system. If your configuration changes are complete, **SELECT** the **Restart** pushbutton on the **Restart** window to make them effective.

## Printer Configuration Information

Table 16 on page 221 describes all configuration items, what each is used for, and the allowable value options for each item. The factory-set default value options are underlined or separately specified.

**Important!** Table 16 on page 221 lists all configuration items for all models of the printers. Some items may be greyed out or not shown for your particular model of printer:

- Configuration items that are marked **(D)** appear only for Duplex systems.
- Configuration items that are marked **(S)** appear only for Simplex systems.
- All unmarked items appear for both Duplex and Simplex systems.

Table 16. Printer Configuration Items

Configuration Item	Description	Value Options
Printer Mode (D)	This entry allows setting whether the duplex system is to be operated in duplex or simplex (dual-simplex) mode. (This item applies to Models ED1/ED2.)  If you change the Printer Mode, the <b>Restart</b> procedure automatically executes a Shutdown procedure.	<u>Duplex</u> or Simplex
Auto Start	If Yes, all current attachment interface status (enable/disable) is saved during a <b>Shutdown</b> procedure, and automatically restored at the next power on of the system. Simplex and dual simplex printers are also automatically made Ready at the completion of the power on sequence. The Thread/Align forms procedure must be performed on duplex printers before the system can be made Ready.	Yes or <u>No</u>
PQE boldness for printer 1	This item must not be changed. <b>Note:</b> If this value is changed accidentally, set the value to 85 and inform the CE during the next visit.	100%
PQE boldness for printer 2 (D)	See entry for printer 1.	See entry for printer 1.
Printer 1 Counter	(CE Change Only) The Print Usage Count from the mechanical counter at the rear of the printer may be transferred to this counter, which will then become a new base count in the running "Printer 1 Counter" displayed in the <b>Printer Status</b> Display Touch Screen window.	0 to 2 000 000 000
Printer 2 Counter (D)	(CE Change Only) The Print Usage Count from the mechanical counter at the rear of the printer may be transferred to this counter, which will then become a new base count in the running "Printer 2 Counter" displayed in the <b>Printer Status</b> Display Touch Screen window.	0 to 2 000 000 000
Printhead resolution	This parameter changes the resolution that the printhead in this printer uses. Not all values are supported on all printers.	Valid values are 480 or 600 DPI. The value you select depends on what features are installed on the printer.
IPDS Resolution	This parameter can only be set when a printhead resolution of 600 DPI is selected.	Automatic, 240 DPI, 300 DPI, or 600 DPI
Font Enhancement	This parameter is used to activate or deactivate the edge smoothing algorithm for raster fonts. Set to No if edge smoothing is not desired.	<u>Yes</u> or No
Jam Recovery Type	This entry controls under what conditions the host system will automatically retransmit pages after a forms jam has been cleared.  <ul style="list-style-type: none"> <li>• Normal Jam Repositioning - All lost pages are automatically retransmitted and reprinted.</li> <li>• Suppress All Jam Repositioning - No lost pages will be retransmitted. Any missing or damaged pages must be manually recovered.</li> </ul>	<ul style="list-style-type: none"> <li>• <u>Use Normal Jam Repositioning</u></li> <li>• Suppress All Jam Repositioning</li> </ul>

Table 16. Printer Configuration Items (continued)

Configuration Item	Description	Value Options
Font Usage	<p>Font usage allows you to select the amount of memory that the printer control unit (computer) will use for font management. Select the font usage according to the type of print jobs you run.</p> <p>Select Low font usage for jobs using a normal number of fonts with normal point sizes, but not double-byte fonts. Medium font usage indicates an abnormal single-byte character set (SBCS) printing mode; select it for jobs using a large number of fonts or very large point sizes, but not double-byte fonts. High font usage is primarily for double-byte font jobs.</p>	<u>Low</u> , Medium, or High
Page Segment Usage	This is used to allocate space for IPDS source for page segments and overlays. Set to Low if the size or number of page segments and overlays is a small. Set to High if the size or number of page segments and overlays is large.	Low, <u>Medium</u> , or High
Overlay Usage	This parameter is used to allocate space for a cache of ready-to-print overlays. Set to Low if a few small overlays are used. Set to High if many or large overlays are used.	Low, <u>Medium</u> , or High
Overlay Cache	This parameter is used to activate or deactivate overlay caching. Set to No if overlays are not reused multiple times or if overlays are not reused in the same location on subsequent pages.	<u>Yes</u> or No
Input Buffer Size	This parameter is used to allocate space for the IPDS data that was just received from the server before being processed by the control unit. Set to Low if pages contain little data or if printing from PSF/MVS on a System/370 channel or an ESCON channel (this is because of the frequent IPDS acknowledgment rate). Set to High if printing pages with large amounts of data (such as large images).	Low, <u>Medium</u> , or High
Output Buffer Size	<p>This parameter is used to allocate space for ready-to-print pages, including pages between the transfer points of a continuous-forms, duplex printer. Set the value to Low if these conditions are met:</p> <ul style="list-style-type: none"> <li>• The pages contain little data</li> <li>• This is a simplex printer</li> <li>• This is a duplex printer with a distance between transfer points of less than 400 inches.</li> </ul> <p>Set the value to High if these conditions are met:</p> <ul style="list-style-type: none"> <li>• The pages contain large amounts of data, especially shaded areas</li> <li>• This is a duplex printer with a distance between transfer points of over 400 inches.</li> </ul>	Low, <u>Medium</u> , or High
Direct Attach	<p>This entry shows if printing is to occur in direct-printing mode when connected to an MVS or OS/390 operating system, with no host-assisted recovery procedures such as retransmission of pages after a forms jam.</p> <p>The host system programmer will inform you whether this entry should be set to <b>Yes</b>.</p>	Yes or <u>No</u>

Table 16. Printer Configuration Items (continued)

Configuration Item	Description	Value Options
NPRO Length	<p>This entry sets an <i>extra</i> length that is added to the fixed NPRO length to create a total distance that forms are moved through the printer.</p> <p>This entry can be used when an uncoupled (not functionally attached) postprocessing device is installed and it is necessary to extend the NPRO length to be able to easily remove forms at the postprocessing device output.</p> <p>If any installed and enabled preprocessing/postprocessing devices have the “Pre/postprocessor Extended NPRO” distance of an enabled pre/postprocessor set to greater than zero, then that distance will take precedence over the “NPRO Length”, even if the “NPRO Length” is longer. The “Pre/postprocessor Extended NPRO” distance is set in the <b>Configure Pre/Post</b> procedure. If several “Pre/postprocessor Extended NPRO” distances are set, then the longest one takes precedence.</p>	Range of <u>0</u> to 1200 inches.
Auto NPRO at End of Forms	This entry indicates whether an automatic NPRO is performed when an End of Forms is detected.	Yes or <u>No</u>
Jam Recovery Point Distance	<p>This entry sets a distance past the printer fuser sufficient for forms to reach an installed postprocessing device, so that those forms will be reprinted following a forms jam recovery.</p> <p>In duplex mode, this distance is measured past the fuser of Printer 2. In dual simplex mode, it is a distance past either Printer 1 or Printer 2.</p> <p>A non-zero value setting assumes that: a postprocessing device is installed and enabled, the “Jam Recovery Type” configuration item setting above allows reprinting of pages, and the “Direct Attach” configuration item setting above is <b>No</b>.</p>	Range of <u>0</u> to 500 inches.
Form Feed Length (D)	This entry sets the length, in inches, that forms are to be moved forward through Printer 1 when the <b>Feed Forms</b> pushbutton is selected during execution of the <b>Thread/Align Forms</b> procedure in duplex mode.	Range of 17 to 250 inches. Default is 60 inches.
Length of Forms Between Transfer Points (D)	<p>This entry sets the length, in inches, of the forms path length from the alignment mark on the transfer station tractors of Printer 1, through Printer 1, across the floor to the Buffer/Flipper Unit, through the Buffer/Flipper Unit, across the floor to Printer 2, under Printer 2 up to the alignment mark on the transfer station tractors of Printer 2. This is used during the duplex mode procedure <b>Thread/Align Forms</b>. If you are continually feeding paper at either printer in order to get the forms aligned, this configuration item may have to be changed.</p> <p>See “Appendix B. Physical System Layouts” on page 293 for physical layout details and dimensions.</p>	Range of 150 to 800 inches. Default is 315 inches.

Table 16. Printer Configuration Items (continued)

Configuration Item	Description	Value Options
Front Sheet Sequence (D)	<p>This entry sets whether the front side of the forms will be printed on Printer 1 or Printer 2 in duplex mode.</p> <p>Front First means that the odd pages (1st, 3rd, 5th,...) of a customer job will print on Printer 1, and the even pages (2nd, 4th, 6th, ...) pages will print on Printer 2. Front Second means just the opposite of Front First.</p> <p>When a postprocessing device is being used that bursts and stacks the output, the "Front Second" setting will deliver output with the odd number pages facing to the front.</p>	Front <u>F</u> irst or Front <u>S</u> econd
Verification Marks (D)	<p>Indicates if verification marks (numbers) are to be printed on the edge (tractor hole area) of each side of forms. When these marks are printed, it is possible to verify that the forms are synchronized or aligned (the two sides of the form coincide).</p> <p>The verification numbers can be read by the operator. If the number on side 1 of a form matches that on side 2, then the forms are properly synchronized. Multiple copies of the same page will have the same verification mark numbers.</p>	Yes or <u>N</u> o
Logical Page Increment	<p>This entry allows expansion of the logical page size for cases where the printed page is larger than the valid InfoPrint 3000 printable area, without errors being set. This case may be encountered when a print job created for a 3800 prints too close to the page edge.</p> <p>The value entered will increase the valid printable area by that number of pels in all directions. Please review your applications to ensure that this setting does not cause loss of data, such as printing on the tractor hole carrier strip that will be trimmed off.</p>	Range of <u>0</u> to 20 pels.
Clear Memory for Security	<p>This entry allows setting of whether residual print data is to be cleared from memory. Clearing memory can result in a delay of up to two minutes before a print job starts. Select <b>Yes</b> if a high level of security is required.</p>	Yes or <u>N</u> o
Screen Saver Timeout	<p>This entry allows specifying, in minutes, the idle time before the Display Touch Screen monitor screen is blanked out. This extends the life of the monitor screen. A value of 0 means the screen saver is not used.</p> <p>In dual simplex mode, if Printer 1 and Printer 2 are set with different values, the shortest setting time is used even if the associated printer console is not being used.</p> <p>Touching a blank screen caused by this timeout restores the display.</p>	0 to 60 minutes. Default is 10 minutes.
Alarm Suppression	<p>This entry allows suppression of the Operator Alert alarm tone for error and supply-item actions.</p>	Yes or <u>N</u> o



Table 16. Printer Configuration Items (continued)

Configuration Item	Description	Value Options
Fuser Inactivity Timer	This entry sets the time, in hours, of printer inactivity before the fuser is turned off. This saves electrical power costs and extends the life of the printer. The fuser automatically turns on when printing resumes, with a delay until the fuser has reached operating temperature. A value of 0 means that the timer is not used.	0 to 9 hours. Default is 1 hour.
Eject to Front Facing	This entry allows accepting or rejecting the Eject to Front Facing (EFF) signals sent by the host. A No value will suppress EFFs. If Yes, the EFF signal from the host will cause a blank page to be inserted between print jobs if the prior job contained an odd number of pages.  This option should be set to <b>No</b> if either a postprocessing device is installed that bursts and stacks output pages, or if Direct Attach is set to Yes.	Yes or <u>No</u>
Form Definition Order	When selected, the form definitions are listed in the order that they were entered.	<u>Yes</u> or No
Stacker Enabled	This entry allows setting of whether or not the stacker is to be used. A setting of <b>Yes</b> implies that a postprocessing device is not being used and that fanfold forms (not roll-feed forms) are being used.  However, if a postprocessing device is installed and enabled, a <b>Yes</b> value is ignored.  In duplex mode, it refers only to the Printer 2 stacker. In dual simplex mode, it may refer to either Printer 1 or Printer 2.	<u>Yes</u> or No

Table 16. Printer Configuration Items (continued)

Configuration Item	Description	Value Options
Cut Sheet Emulation	<p>Sheets are divided in half using an imaginary line that is parallel to the tractor strips. Each resulting "half sheet" is treated as if it were a whole sheet running through a cut-sheet printer.</p> <p>None implies the cut-sheet emulation is not enabled.</p> <p>Normal Left-to-Right allows the print data to be placed on the left half-sheet first and then the right half-sheet. The left half-sheet is closest to the operator. The physical orientation of the data is based on the lower-left corner of the paper as viewed from the operator's viewpoint.</p> <p>Normal Right-to-Left allows the print data to be placed on the right half-sheet first and then the left half-sheet. The right half-sheet is furthest from the operator. The physical orientation of the data is based on the lower-left corner of the paper as viewed from the operator's viewpoint.</p> <p>Inverted Left-to-Right allows the print data to be placed on the left half-sheet first and then the right half-sheet. The left half-sheet is furthest from the operator. The physical orientation of the data is based on the upper-right corner of the paper as viewed from the operator's viewpoint. This mode is the "upside down" version of the Normal Left-to-Right mode.</p> <p>Inverted Right-to-Left allows the print data to be placed on the right half-sheet first and then the left half-sheet. The right half-sheet is closest to the operator. The physical orientation of the data is based on the upper-right corner of the paper as viewed from the operator's viewpoint. This mode is the "upside down" version of the Normal Right-to-Left mode.</p>	None, Normal Left-to-Right, Normal Right-to-Left, Inverted Left-to-Right, Inverted Right-to-Left
BTS Installed	This entry allows setting whether a Burster/Trimmer/Stacker postprocessing device is installed. It does not show whether it is being used.	Yes or <u>No</u>
BTS Enabled	This entry allows setting whether an installed Burster/Trimmer/Stacker postprocessing device is being used. The host system will not send eject-to-front-facing commands if the BTS is enabled.	Yes or <u>No</u>
Offsetter Installed	This entry allows setting whether an Offsetter postprocessing device is installed. It does not show whether it is being used.	Yes or <u>No</u>
Offsetter Enabled	This entry allows setting whether an installed Offsetter postprocessing device is being used. The host system will send "Alternate Offset Stacker" commands if the offsetter is enabled and the print job contains these commands.	Yes or <u>No</u>
Offset on Mark Forms	This entry allows setting whether "Alternate Offset Stacker" commands from the host system are passed on to an enabled stacking-type postprocessing device for any page containing the Mark Forms.	Yes or <u>No</u>
3130 Bar Code Compatibility	This entry defines whether bar codes are printed in the standard format or in the format printed by a 3130 printer.	Yes or <u>No</u>

Table 16. Printer Configuration Items (continued)

Configuration Item	Description	Value Options
Preheat Platen Temperature	This entry allows setting the preheat platen temperature to a higher or lower temperature than the default as needed for different types of forms. If 0 (zero) is entered for the preheat platen temperature under Define Forms, the temperature set under Configure Printer is used.  For Models ED1/ED2, a temperature must be set for Printer 1 and Printer 2.	Range of 45 to 100°C — in increments of 5°  Default is 80°C
Scan Factory Adjust for Printer 1	(CE Change Only) This is used by service personnel to adjust the scan direction printing registration.	Range of 0 to 100 units  Default is 40 units  Unit = 2 pels
Process Factory Adjust for Printer 1	(CE Change Only) This is used by service personnel to adjust the process direction printing registration.	Range of 0 to 60 units  Default is 15 units  Unit = 1 pel
Scan Factory Adjust for Printer 2 (D)	(CE Change Only) This is used by service personnel to adjust the scan direction printing registration.	Range of 0 to 100 units  Default is 40 units  Unit = 2 pels
Process Factory Adjust for Printer 2 (D)	(CE Change Only) This is used by service personnel to adjust the process direction printing registration.	Range of 0 to 60 units  Default is 15 units  Unit = 1 pel
Beam 1 offset adjustment	(CE Change Only). This is used by maintenance personnel to control the vertical alignment or horizontal adjustment of the separate beams of a multi-beam printer.	Range of 0.0 to 15.9  Default is 8.0 units  Unit = .1 pel
Beam 2 offset adjustment	(See information in <i>Beam 1 offset adjustment</i> )	(See information in <i>Beam 1 offset adjustment</i> )
Beam 3 offset adjustment	(See information in <i>Beam 1 offset adjustment</i> )	(See information in <i>Beam 1 offset adjustment</i> )
Beam 4 offset adjustment	(See information in <i>Beam 1 offset adjustment</i> )	(See information in <i>Beam 1 offset adjustment</i> )
Beam 5 offset adjustment	(See information in <i>Beam 1 offset adjustment</i> )	(See information in <i>Beam 1 offset adjustment</i> )
Beam 1 offset adjustment for Printer 2 (D)	(See information in <i>Beam 1 offset adjustment</i> )	(See information in <i>Beam 1 offset adjustment</i> )
Beam 2 offset adjustment for Printer 2 (D)	(See information in <i>Beam 1 offset adjustment</i> )	(See information in <i>Beam 1 offset adjustment</i> )
Beam 3 offset adjustment for Printer 2 (D)	(See information in <i>Beam 1 offset adjustment</i> )	(See information in <i>Beam 1 offset adjustment</i> )
Beam 4 offset adjustment for Printer 2 (D)	(See information in <i>Beam 1 offset adjustment</i> )	(See information in <i>Beam 1 offset adjustment</i> )

Table 16. Printer Configuration Items (continued)

Configuration Item	Description	Value Options
Beam 5 offset adjustment for Printer 2 (D)	(See information in <i>Beam 1 offset adjustment</i> )	(See information in <i>Beam 1 offset adjustment</i> )
Machine Sequence for Printer 1	(CE Change on Initial Configuration Only) This is the serial number for Printer 1 (7 numeric only characters). Each time the AFCCU hard disk is replaced, this data is lost; the CE must enter the serial number found on the rear inside of the AFCCU frame again.	N/A
Manufacturing Plant for Printer 1	(CE Change on Initial Configuration Only) This is the code for plant of manufacture of Printer 1 (2 numeric only characters). Each time the AFCCU hard disk is replaced this data is lost; the CE must enter this code again from information saved from the last time Printer Configurations were changed.	N/A
Machine Sequence for Printer 2	(CE Change on Initial Configuration Only) This is the serial number for Printer 1 (7 numeric only characters). Each time the AFCCU hard disk is replaced, this data is lost; the CE must enter the serial number found on the rear inside of the AFCCU frame again.	N/A
Manufacturing Plant for Printer 2	(CE Change on Initial Configuration Only) This is the code for the plant of manufacture of Printer 2 (2 numeric only characters). Each time the AFCCU hard disk is replaced, this data is lost; the CE must enter this code again from information saved from the last time Printer Configurations were changed.	N/A
Date and Time	(CE Change Only). This is in the form of mmddHHMM.ssyy. mm=month dd=day HH=hour MM=minute ss=second yy=year	N/A

---

## Configuring the Host Attachments

This procedure lets you view, print, or change the configuration settings of an installed attachment.

**Note:** The printer can have multiple sets of configuration data: one for each mode in which the printer can operate. To update a configuration for a particular mode, the printer must be running in that mode (for example, Duplex mode).

The following host attachments are available:

- Parallel Channel
- ESCON Channel
- Token Ring TCP/IP
- Ethernet TCP/IP
- FDDI TCP/IP (for Models ED1/ED2 only)

Before you change a configuration value, please review the configuration information table for the attachment configuration you are changing:

- “Parallel Channel Configuration Information” on page 232
  - “ESCON Channel Configuration Information” on page 234
  - “Token Ring TCP/IP Attachment Information” on page 235
  - “Ethernet TCP/IP Attachment Information” on page 237
  - “FDDI TCP/IP Attachment Information” on page 239
1. Before you *print* the attachment configuration, ensure that all attachments are disabled. See “Enabling and Disabling Attachments” on page 63 for more information. You do not need to disable attachments if you are viewing or changing the configuration.
  2. To access the configuration settings, do one of the following:
    - In duplex mode, **SELECT** the **Configure** pull-down menu on the main Display Touch Screen window.
    - In dual simplex mode, **SELECT** the **Configure** pull-down menu on the Display Touch Screen window of the printer with which you want to work.
  3. **SELECT** the **Configure Attachments** procedure. You see the **Configure Attachments** window. This window lists the attachments that are currently installed. It also lists the attachments that are not installed but are present in the control unit and could be installed.

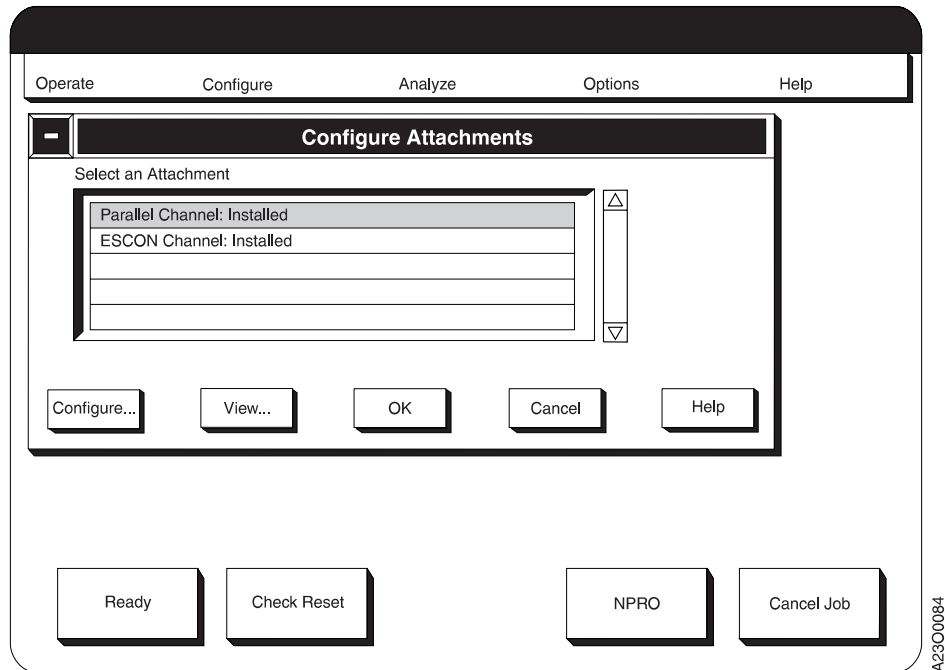

4. To **view** configuration information for an attachment, do the following:
  - a. **SELECT** an attachment type from the list.
  - b. **SELECT** the **View...** pushbutton. You see the **View Configuration** window.
5. To **print** a copy of the configuration information for an attachment, do the following:
  - a. **SELECT** an attachment type from the list.
  - b. **SELECT** the **View...** or **Configure...** pushbutton.
  - c. On the resulting window, **SELECT** the **Print...** pushbutton. You see the **Print Configuration** window.
  - d. To change the number of copies you print, do the following:
    - 1) **SELECT** the **How Many?** field.
    - 2) Type the number of copies you want to print.
    - 3) **SELECT** the **OK** pushbutton.
  - e. **SELECT** the **Print** pushbutton on the **Print Configuration** window.

**Important**

The configuration data is always printed in U.S. English.

6. To **change** configuration information for an attachment, do the following:
  - a. **SELECT** an attachment type.
  - b. **SELECT** the **Configure...** pushbutton. You see a list of configuration items for the attachment.
  - c. To change an item:
    - 1) **SELECT** it from the list. You see either a pop-up window or a keypad window.
    - 2) **SELECT** the value you want from the pop-up window, or enter data on the keypad window. Then **SELECT** the **OK** pushbutton.  
Repeat this step for as many items as you want to change.

- d. When you have made all the changes, **SELECT** the **OK** pushbutton. You see the **Configure Attachments** window. If you want to change configuration information for other attachments, repeat the previous steps as necessary.
- e. When you have made all attachment changes, **SELECT** the **OK** pushbutton on the **Configure Attachments** window. You see the **Restart** prompting window.
- f. If you have other configuration changes to make, you can make them before you restart the system. If your configuration changes are complete, **SELECT** the **Restart** pushbutton to make them effective.

**Note**

**SELECTING Restart** does the following:

- If you are making this change in duplex or simplex mode, a window appears that informs you that an automatic **Shutdown** procedure has started. This window is followed by a window stating that the system is being *rebooted* (AFCCU microcode is being reloaded). At the completion of the microcode reload, the attachment changes are in effect. You do not have to power off the system and then power it on.
- If you are making this change in dual simplex mode, the Display Touch Screen screen goes blank while an internal **Shutdown** procedure is executed on the printer on which you are working. The system then displays a message that indicates that the other printer must be shutdown for the changes to take affect. This message is followed by the Display Touch Screen window for the other printer.

You must select the **Shutdown/Restart** procedure from the **Operate** pull-down menu on that Display Touch Screen window, and then execute the **Shutdown** routine. A window appears stating that the system is being “rebooted”. At the completion of the reboot, the attachment changes are in effect with no system power-off and power-on procedure required.

## Parallel Channel Configuration Information

Table 17 lists all configuration items, the purpose of each item, and the allowable value options for each item. The factory-set default values are underlined.

Table 17. Parallel Channel Attachment Items

Configuration Item	Description	Value Options
Parallel Link A Installed	Specifies if Parallel Channel Link A is installed.	Yes or <u>No</u>
Parallel Link B Installed	Specifies if Parallel Channel Link B is installed.	Yes or <u>No</u>
Device Address	<p>Specifies the 2-digit hexadecimal channel address which includes the device address.</p> <p><b>Notes:</b></p> <ol style="list-style-type: none"> <li>1. In simplex mode, only one device address is required. In dual simplex mode, each printer requires a unique device address. Printer 1 requires an even number (for example, X'30'); Printer 2 requires the next consecutive number (for example, X'31').</li> <li>2. The duplex system does not require a unique number. It can use either of the addresses used for dual simplex Printer 1 or dual simplex Printer 2. However, it is often easier from an operational viewpoint to assign duplex a separate address (so the duplex and simplex printers look like unique devices to the operating system). The general convention in this case is to assign the duplex system the next consecutive address (even) after the address for simplex Printer 2. For example, if you define Printer 1 in dual simplex as X'30', you should then define Printer 2 in dual simplex as X'31', and, optionally, define the complete system in duplex as X'32'.</li> <li>3. The device addresses specified above must match the device addresses defined to the host PSF software, and in the case of S/390 hosts, the I/O device definitions.</li> </ol>	00 to FF (Hexadecimal notation). Default is X'00'
Second Channel	<p>Specifies the switching mode of the Two-Channel Switch: Static or Dynamic Mode. When a second Parallel Channel is installed, a Two-Channel Switch facility is provided.</p> <ul style="list-style-type: none"> <li>• <b>Static:</b> You can enable only one channel at a time. You can connect two interfaces to two channels on the same processing unit, on tightly coupled processing units (units controlled by the same operating system), or on independent (uncoupled) processing units.</li> <li>• <b>Dynamic:</b> You can enable both channels at the same time with the two-Channel Switch used as a dynamic interface switch. Connect the two interfaces to two channels either on the same processing unit or on tightly-coupled processing units (units controlled by the same operating system).</li> </ul> <p>You cannot select this item unless two channels are installed.</p>	<u>Static</u> or Dynamic



Table 17. Parallel Channel Attachment Items (continued)

Configuration Item	Description	Value Options
Data Transfer Protocol	Specifies the data transfer mode to be used: DC Interlocked or Data-Streaming.  If two channels are installed, both channels use the same protocol.	<u>Interlocked</u> or Data Streaming
Data Streaming Rate	Specifies the data rate being used if you select the Data-Streaming Data Transfer Protocol. Use the highest rate that is supported by your system.  If two channels are installed, both channels use the same data rate.	<ul style="list-style-type: none"> <li>• 1.9 MB/sec</li> <li>• <u>2.7 MB/sec</u></li> <li>• 3.4 MB/sec</li> <li>• 4.5 MB/sec</li> </ul>
Card 1 Slot Position	The printer sets this entry automatically at power on time if the system senses the presence of a Parallel Channel card. This item is not selectable.	<ul style="list-style-type: none"> <li>• 2 or 4 or Not Installed (for Model ES1)</li> <li>• 6 or 8 or Not Installed (for Models ED1/ED2)</li> </ul>
Card 2 Slot Position	The printer sets this entry automatically at power on time if the system senses the presence of a Parallel Channel card. This item is not selectable.	<ul style="list-style-type: none"> <li>• 2 or 4 or Not Installed (for Model ES1)</li> <li>• 6 or 8 or Not Installed (for Models ED1/ED2)</li> </ul>

## ESCON Channel Configuration Information

Table 18 lists all configuration items, what each item is used for, and the allowable value options for each item. The factory-set default values are underlined.

Table 18. ESCON Channel Attachment Items

Configuration Item	Description	Value Options
ESCON Link A Installed	Specifies if ESCON Channel Link A is installed.	Yes or <u>No</u>
ESCON Link B Installed	Specifies if ESCON Channel Link B is installed.	Yes or <u>No</u>
Device Address	<p>Specifies the 2-digit hexadecimal channel address which includes the device address.</p> <p><b>Notes:</b></p> <ol style="list-style-type: none"> <li>1. In simplex mode, only one device address is required.</li> <li>2. In dual simplex mode, each printer requires a unique device address. Printer 1 requires an even number (for example, X'30'); Printer 2 requires the next consecutive number (for example, X'31').</li> <li>3. The duplex system does not require a unique number. It can use either of the addresses used for dual simplex Printer 1 or dual simplex Printer 2. However, it is often easier from an operational viewpoint to assign duplex a separate address (so the duplex and simplex printers look like unique devices to the operating system). The general convention in this case is to assign the duplex system the next consecutive address (even) after the address for simplex Printer 2. For example, if you define Printer 1 in dual simplex as X'30', you should then define Printer 2 in dual simplex as X'31', and, optionally, define the complete system in duplex as X'32'.</li> <li>4. The device addresses specified above must match the device addresses defined to the host PSF software, and in the case of S/390 hosts, the I/O device definitions.</li> </ol>	00 to FF (Hexadecimal notation). Default is X'00'
Multi-host environment flag	Shows whether a multiple host printer-sharing system exists. If this environment flag is set, all hosts are required to use the assign/unassign protocols of the attachment architecture. (Not supported on all printers.)	True or <u>False</u>
Card 1 Slot Position	The printer sets this entry automatically at power on time if the system senses the presence of an ESCON Channel card. This item is not selectable.	<ul style="list-style-type: none"> <li>• 2 or 4 or Not Installed (for Model ES1)</li> <li>• 6 or 8 or Not Installed (for Models ED1/ED2)</li> </ul>
Card 2 Slot Position	The printer sets this entry automatically at power on time if the system senses the presence of an ESCON Channel card. This item is not selectable.	<ul style="list-style-type: none"> <li>• 2 or 4 or Not Installed (for Model ES1)</li> <li>• 6 or 8 or Not Installed (for Models ED1/ED2)</li> </ul>

## Token Ring TCP/IP Attachment Information

Table 19 lists all configuration items, what each item is used for, and the allowable value options for each item. The factory-set default values are underlined.

Table 19. Token Ring TCP/IP Attachment Items

Configuration Item	Description	Value Options
Token Ring TCP/IP Installed	Specifies if the Token Ring adapter is installed.	Yes or <u>No</u>
TCP Port	<p>Specifies the TCP socket address of the attachment.</p> <p><b>Notes:</b></p> <ol style="list-style-type: none"> <li>1. Only one address is required for operating a simplex system.</li> <li>2. If your installation runs in dual simplex and duplex mode, specify the same TCP Port value for duplex mode as you do for Printer 1 in dual simplex mode. (IBM recommends using the default value of 5001.) Also, make sure you specify a unique value for Printer 2 in simplex mode; Printer 1 and Printer 2 cannot use the same value. (If you use the default value of 5001, for Printer 1, IBM recommends using 5002 as the value for Printer 2.)</li> <li>3. The TCP Port numbers specified in the printer configuration must match the PORT numbers assigned in the host PSF system.</li> <li>4. Because Printer 1 in a dual simplex system and the complete system in duplex system share a common port number, operational procedures must be defined to distinguish between duplex and dual simplex printing. The easiest way to manage this is to assign separate queues for duplex versus dual simplex output (for PSF/2 and PSF/6000), and to assign at least a unique job class for duplex jobs (for S/390 host PSF systems).</li> </ol>	5001 to 65536.
IP Address	<p>Specifies the Internet protocol (IP) address of the printer in dotted decimal format. Get this value from your LAN administrator. This value must match the IP address value in the host PSF configuration.</p> <p>This value is unique to a duplex system, and is the same regardless of whether the printer is in duplex or dual-simplex mode.</p>	X.X.X.X where X ≤ 255.
Subnet Mask	Specifies the mask that identifies the local subnet in dotted decimal format. Get this value from your LAN administrator. If you do not have a local subnet, leave this field blank.	X.X.X.X where X ≤ 255
Default Gateway Address	Specifies the IP address of the default gateway in dotted decimal format. Get this value from your LAN administrator.	X.X.X.X where X ≤ 255
MTU Size	Specifies the Maximum Transmission Unit (MTU) – maximum allowable length of IP packets.	60 to 4096
Hardware address	Specifies the TCP/IP Token Ring adapter ROM address.	This address cannot be changed.

Table 19. Token Ring TCP/IP Attachment Items (continued)

Configuration Item	Description	Value Options
Alternate address (Local adapter address)	Sets the unique LAN adapter address for the network. The address must be different from other addresses on the LAN.	X'0' to X'FFFFFFFFFFFF'
Ring Speed	Specifies the ring speed of the network to which the adapter attaches. The value must match the speed of the network or the network may stop operating.	4 or 16
Confine Broadcast	Specifies if broadcast packets (that is, Address Resolution Protocol packets) are enabled to cross bridges to other rings.	Yes or <u>No</u>

## Ethernet TCP/IP Attachment Information

Table 20 lists all configuration items, what each item is used for, and the allowable value options for each item. The factory-set default values are underlined.

Table 20. Ethernet TCP/IP Attachment Items

Configuration Item	Description	Value Options
Ethernet TCP/IP Installed	Specifies if the Ethernet adapter is installed.	Yes or <u>No</u>
TCP Port	<p>Specifies the TCP socket address of the attachment.</p> <p><b>Notes:</b></p> <ol style="list-style-type: none"> <li>1. Only one address is required for operating a simplex system.</li> <li>2. If your installation runs in dual simplex and duplex mode, specify the same TCP Port value for duplex mode as you do for Printer 1 in dual simplex mode. (IBM recommends using the default value of 5001.) Also, make sure you specify a unique value for Printer 2 in simplex mode; Printer 1 and Printer 2 cannot use the same value. (If you use the default value of 5001, for Printer 1, IBM recommends using 5002 as the value for Printer 2.)</li> <li>3. The TCP Port numbers specified in the printer configuration must match the PORT numbers assigned in the host PSF system.</li> <li>4. Because Printer 1 in a dual simplex system and the complete system in duplex system share a common port number, operational procedures must be defined to distinguish between duplex and dual simplex printing. The easiest way to manage this is to assign separate queues for duplex versus dual simplex output (for PSF/2 and PSF/6000), and to assign at least a unique job class for duplex jobs (for S/390 host PSF systems).</li> </ol>	5001 to 65536
IP Address	<p>Specifies the Internet Protocol (IP) address of the printer in dotted decimal format. Get this value from your LAN administrator. This value must match the IP address value in the host PSF configuration.</p> <p>This value is unique to a duplex system, and is the same regardless of whether the printer is in duplex or dual-simplex mode.</p>	X.X.X.X where X ≤ 255.
Subnet Mask	Specifies the mask that identifies the local subnet in dotted decimal format. Get this value from your LAN administrator. If you do not have a local subnet, leave this field blank.	X.X.X.X where X ≤ 255
Default Gateway Address	Specifies the IP address of the default gateway in dotted decimal format. Get this value from your LAN administrator.	X.X.X.X where X ≤ 255
Standard MTU Size	Specifies the Maximum Transmission Unit (MTU) size. The MTU size for Standard Ethernet type ranges from 60 to 1500.	60 to 1500
IEEE802.3 MTU Size	Specifies the MTU size for IEEE802.3 Ethernet type. The range is from 60 to 1492.	60 to 1492

Table 20. Ethernet TCP/IP Attachment Items (continued)

Configuration Item	Description	Value Options
Ethernet Type	Specifies either the Standard or the IEEE802.3 Ethernet type.	Standard or IEEE802.3
Hardware address	Specifies the TCP/IP Token Ring adapter ROM address.	This address cannot be changed.
Alternate address (Local adapter address)	Sets the unique LAN adapter address for the network. The address must be different from other addresses on the LAN.	X'0' to X'FFFFFFFFFFFF'
Cable type	This is the type of Ethernet cable connector used in the back of the printer.	10Base2 or 10Base5

## FDDI TCP/IP Attachment Information

Table 21 lists all configuration items, what each item is used for, and the allowable value options for each item. The factory-set default values are underlined.

Table 21. FDDI TCP/IP Attachment Items

Configuration Item	Description	Value Options
FDDI TCP/IP Installed	Specifies if the FDDI adapter is installed.	Yes or <u>No</u>
TCP Port	<p>Specifies the TCP socket address of the attachment.</p> <p><b>Notes:</b></p> <ol style="list-style-type: none"> <li>1. Only one address is required for operating a simplex system.</li> <li>2. If your installation runs in dual simplex and duplex mode, specify the same TCP Port value for duplex mode as you do for Printer 1 in dual simplex mode. (IBM recommends using the default value of 5001.) Also, make sure you specify a unique value for Printer 2 in simplex mode; Printer 1 and Printer 2 cannot use the same value. (If you use the default value of 5001, for Printer 1, IBM recommends using 5002 as the value for Printer 2.)</li> <li>3. The TCP Port numbers specified in the printer configuration must match the PORT numbers assigned in the host PSF system.</li> <li>4. Because Printer 1 in a dual simplex system and the complete system in duplex system share a common port number, operational procedures must be defined to distinguish between duplex and dual simplex printing. The easiest way to manage this is to assign separate queues for duplex versus dual simplex output (for PSF/2 and PSF/6000), and to assign at least a unique job class for duplex jobs (for S/390 host PSF systems).</li> </ol>	5001 to 65536.
IP Address	<p>Specifies the Internet protocol (IP) address of the printer in dotted decimal format. Get this value from your LAN administrator. This value must match the IP address value in the host PSF configuration.</p> <p>This value is unique to a duplex system, and is the same regardless of whether the printer is in duplex or dual-simplex mode.</p>	X.X.X.X where X ≤ 255.
Subnet Mask	Specifies the mask that identifies the local subnet in dotted decimal format. Get this value from your LAN administrator. If you do not have a local subnet, leave this field blank.	X.X.X.X where X ≤ 255
Default Gateway Address	Specifies the IP address of the default gateway in dotted decimal format. Get this value from your LAN administrator.	X.X.X.X where X ≤ 255
MTU Size	Specifies the Maximum Transmission Unit (MTU) – maximum allowable length of IP packets.	256 to <u>4352</u>
Hardware address	Specifies the FDDI adapter ROM address.	This address cannot be changed.

Table 21. FDDI TCP/IP Attachment Items (continued)

Configuration Item	Description	Value Options
Alternate address (Local adapter address)	Sets the unique LAN adapter address for the network. The address must be different from other addresses on the LAN.	X'0' to X'FFFFFFFFFFFF'
Confine Broadcast	Specifies if broadcast packets (that is, Address Resolution Protocol packets) are enabled to cross bridges to other rings.	Yes or <u>No</u>



---

## Configuring Preprocessing/Postprocessing Devices/Interfaces

This procedure lets you add, delete, or change specifications for preprocessing and postprocessing device interface features. You may configure and store up to ten defined preprocessing/postprocessing devices, each configured for either Printer 1 or Printer 2. But only three devices may be enabled for each printer. The printers have three interface ports. These ports may be equipped with Preprocessing/Postprocessing (Pre/Post) or Advanced Function Postprocessing (AF Post) interfaces as shown in Table 22. Port 1 comes standard with a Pre/Post device interface adaptor, and the following table assumes that adaptor is installed.

Table 22. Preprocessing/Postprocessing Interface Options

Port	Configuration Options					
1	Pre/Post	Pre/Post	Pre/Post	Pre/Post	Pre/Post	Pre/Post
2	—	Pre/Post	Pre/Post	AF Post	Pre/Post	AF Post
3 <sup>1</sup>	—	—	Pre/Post	—	AF Post	Pre/Post

<sup>1</sup> Port 3 is not available on Model ES1.

The procedure for changing your pre/postprocessor configuration follows:

1. Do one of the following:
  - In duplex or simplex mode, **SELECT** the **Configure** pull-down menu on the main Display Touch Screen window. You can work with all configured preprocessing and postprocessing devices.
  - In dual simplex mode, **SELECT** the **Configure** pull-down menu on the Display Touch Screen window of the printer with which you want to work. You can work with only the preprocessing and postprocessing devices that are configured for that printer.
2. **SELECT** the **Configure Pre/postprocessors** procedure. You see the **Configure Pre/postprocessors** window, which lists the device interfaces that are currently defined and installed.

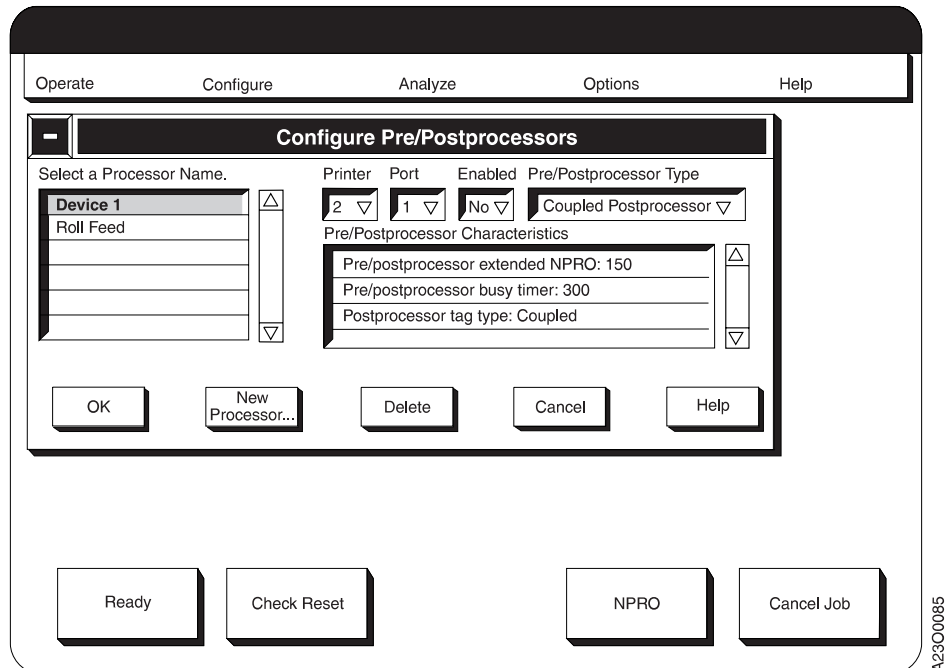

Figure 35. Configure Pre/Postprocessors Window - Duplex Mode

3. To **add** a new interface, do the following:
  - a. **SELECT** the **New Processor...** pushbutton.
  - b. Use the keyboard to enter the name of the interface you are adding.
  - c. **SELECT** the keyboard **OK** pushbutton.
  - d. Change the configuration information for the new interface (see the next step).
4. To **change** the values that are assigned to an interface, do the following:
  - a. **SELECT** from the **Select a Processor Name** selection list box the name of the device interface you want to change. The window shows the current values for the device.
  - b. **SELECT** the field you want to change.
  - c. **SELECT** the new value you want from the pop-up window, or enter data on the keypad window and **SELECT** the **OK** pushbutton.  
Repeat this step for as many items and devices as you want to change.
5. To **delete** a device, do the following:
  - a. **SELECT** from the **Select a Processor Name** box the name of the device you want to delete from the configured list.
  - b. **SELECT** the **Delete** pushbutton.
6. **SELECT** the **OK** pushbutton on the **Configure Pre/Postprocessors** window when you have finished making all changes to the pre/postprocessor configuration.

## Pre/Postprocessor Configuration Values

Table 23 lists all configuration items, what each item is used for, and the allowable value options for each item. The factory-set default values are underlined.

Table 23. Pre/Postprocessor Device Configuration Items

Selectable Field/Item	Description	Value Options
Printer (This item does not appear for simplex models.)	When the Configure Printer <b>Printer Mode</b> configuration item is set to <b>Simplex</b> mode, this <b>Printer</b> selectable field is grayed out in the <b>Configure Pre/Postprocessors</b> window. All devices configured while in <b>Simplex</b> mode are automatically configured for the printer associated with Display Touch Screen you are currently using.	1 or 2
Port	The physical connection between the printer and the preprocessing/postprocessing device.	1 or 2 or 3
Enabled	<p>Enables a device for a port. If a device is already enabled for a specific port number when you select a device that is also configured for that port number, the <b>Yes</b> is grayed out so that you cannot attempt to enable a second device for the same port.</p> <p>An error window appears when the restart procedure to activate this change is complete and either of the following conditions exist:</p> <ul style="list-style-type: none"> <li>You attempted to enable a device for a port number that does not have an interface adaptor installed or</li> <li>The adapter has a different type (Pre/Post versus AF Post) adaptor installed than the device type you are enabling.</li> </ul>	Yes or No
Pre/Postprocessor Type	<p>Specify a <b>Coupled</b> type when the port to be used has a <b>Pre/Post</b> type adaptor installed.</p> <p>Specify an <b>Advanced Postprocessor</b> type when the port to be used has a <b>AF Post</b> type adaptor installed.</p> <p>Different types have different <b>Pre/Postprocessor Characteristics</b> configuration items listed.</p>	<p>Options Include:</p> <ul style="list-style-type: none"> <li>Coupled Preprocessor</li> <li>Coupled Postprocessor</li> <li>Advanced Postprocessor - MICR</li> <li>Advanced Postprocessor - SMM (Select Medium Modification)</li> </ul>
<b>Pre/Postprocessor Characteristics:</b>		
Pre/Postprocessor Extended NPRO (non-process runout).	<p>Listed for all Pre/Postprocessor Types.</p> <p>Extends the NPRO. Enter a non-zero value to extend the fixed NPRO length because of preprocessing or postprocessing device usage.</p> <p>Setting the "NPRO Length" configuration item under the <b>Configure Printer</b> also sets this function. The "Pre/Postprocessor Extended NPRO" value overrides the "Configure Printer NPRO Length" value if both are set to non-zero values.</p>	0 to 800 inches. Default is <u>150</u> .
Pre/Postprocessor Busy Timer	<p>Listed only for "Coupled" Pre/Postprocessor Types.</p> <p>Specifies the length of time in seconds that follows a Preprocessing or Postprocessing device going to "Busy" status before the status automatically changes to "Not Ready." The printer does not report "Busy" status to the host system, but does report "Not Ready" status.</p>	1 to 999 seconds. Default is <u>300</u> .

Table 23. Pre/Postprocessor Device Configuration Items (continued)

Selectable Field/Item	Description	Value Options
Postprocessor Tag Type	<p>Listed only for “Coupled” Pre/Postprocessor Types.</p> <p>Specify a <b>Coupled</b> tag type for all Postprocessing devices not manufactured by Roll System, Inc.</p> <p>Specify an <b>RSI Compatible</b> tag type for all Postprocessing devices manufactured by Roll System, Inc..</p>	<ul style="list-style-type: none"> <li>• <u>Coupled</u></li> <li>• RSI Compatible</li> </ul> <p>This item is ignored if you are configuring a preprocessing device interface.</p>
Distance to Postprocessor	<p>Listed only for “Advanced Postprocessor” Pre/Postprocessor Types.</p> <p>If two AF postprocessors are installed, the distance of the second postprocessor must exceed that of the first.</p> <ul style="list-style-type: none"> <li>• If the first postprocessor is a Troy MICR 3900, add an extra 102 inches to the actual measured distance from the printer to the second postprocessor.</li> <li>• If the first postprocessor is a Troy MICR 3900 High Speed, add an extra 148 inches to the actual measured distance from the printer to the second postprocessor.</li> <li>• If the first postprocessor is a Troy MICR 3835, add an extra 99 inches to the actual measured distance from the printer to the second postprocessor.</li> </ul> <p>For more information, see <i>Using the IBM 3835 Page Printers and the IBM 3900 Advanced Function Printers with the Troy MICR Printers</i>, GA32-0261.</p>	<ul style="list-style-type: none"> <li>• 24 to 800 inches. Default is <u>99</u>.</li> <li>• 24 to 1200 inches. Default is <u>99</u>.</li> </ul>
Postprocessor Error Page Stop	Listed only for “Advanced Postprocessor - MICR” Pre/Postprocessor Type.	<u>0</u> to 50 pages
Postprocessor Verify Alignment Page Stop	Listed only for “Advanced Postprocessor - MICR” Pre/Postprocessor Type.	<u>0</u> to 5000 pages
Pre/Postprocessor Baud Rate in Kbps	Listed only for “Advanced Postprocessor” Pre/Postprocessor Types.	19.2 or <u>62.5</u>

## Configuring Remote Access

This procedure lets you enable and configure remote access to the printer. You can use these methods:

- SNMP (Simple Network Management Protocol)
- RMI (Remote Management Interface)
- Modem.

To configure remote access, do the following:

1. **SELECT** the **Configure** pull-down menu on the main Display Touch Screen window.
2. **SELECT** the **Remote Access** procedure.

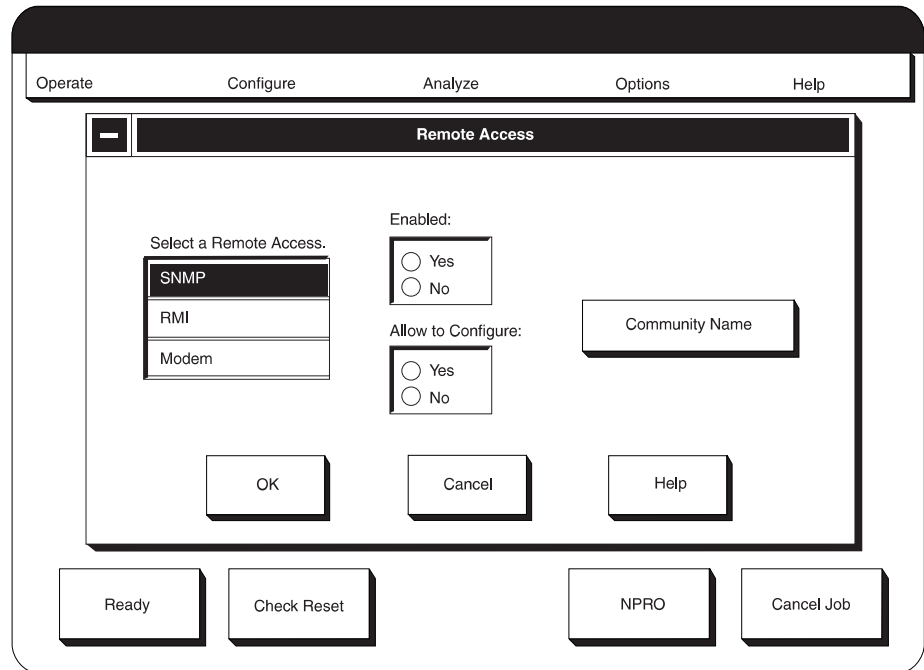

3. **SELECT** the type of remote access that is to be used.
4. Enable or disable remote access for the type of remote access that you chose in the previous step.

**Note:** If **Allow to Configure** is set to **Yes** for SNMP or RMI, that interface is allowed to remotely change selected printer configuration items.

5. **SELECT** the **Community Name** procedure to configure additional SNMP parameters:

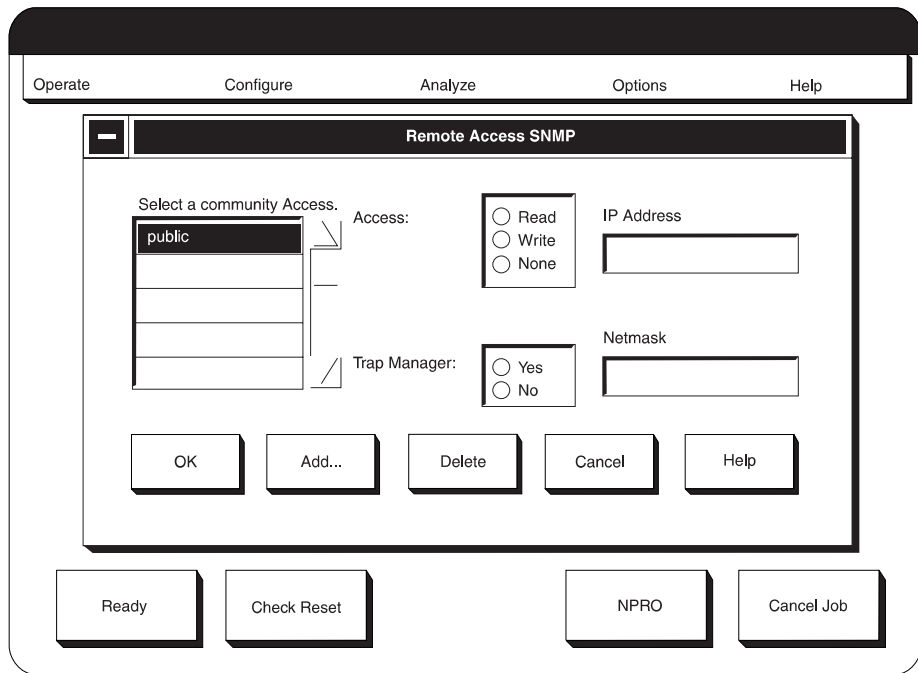

---

## Defining Forms

Use this procedure to define forms. You can add, change, or delete form definitions.

You must define forms to the printer before you can load them. You can define forms in advance as a separate procedure. You can also define forms while you are actually loading the forms.

The printer can store 1024 form name definitions in duplex and simplex modes, and 1024 additional form name definitions for each printer in dual simplex mode for a total of 3072 form name definitions for the complete system. Five form names come standard with each system and appear on the **Define Forms** panel on the Display Touch Screen.

Use the “Form Identification Worksheets” on page 263 before installation of the printer to define the forms your installation is planning to use. Continue using the forms during the life of the system to add additional forms definitions.

Form names that are defined and stored while the printer is in duplex mode are listed and available for assignment/change/deletion only in duplex mode. Likewise, a form name that is defined and stored in either Printer 1 dual simplex or Printer 2 dual simplex mode are listed and available for assignment/change/deletion only when the printer is in simplex mode.

To define new forms or delete existing forms, do the following:

1. Ensure that the printer is in Not Ready status.
2. **SELECT** the **Configure** pull-down menu on the main Display Touch Screen window.
3. **SELECT** the **Define Forms** procedure. You see the **Define Forms** window, which lists the forms that are currently defined and information about the form name that is highlighted in the list.

**Note:** The **Define Forms** function is not available if the **Assign Forms to Load** or **Print Adjust** screen is displayed. Only one of these three screens appears at any time.

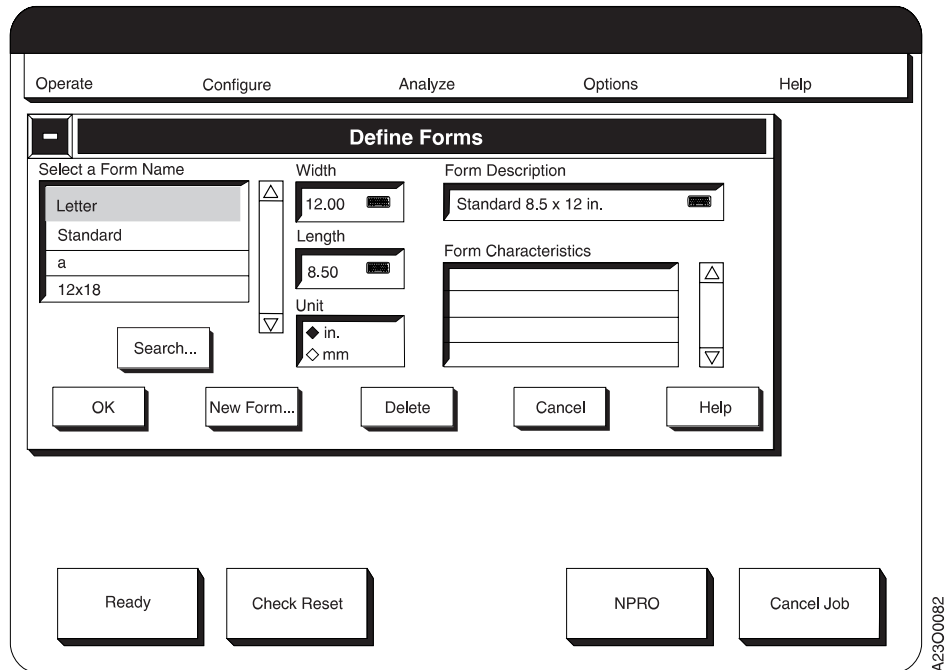

Figure 36. Define Forms Window - Duplex Mode

4. To find a particular form name, **SELECT** the **Search** pushbutton. A keyboard appears so you can enter the form name.

**Note:** Use care when you define a form name. Searching for form names is case sensitive; that is, if capital letters are used to define the form, you must use them to enter the form name for a search.

5. To **delete** a form, do the following:
  - a. **SELECT** the form you want to delete from the list.
  - b. **SELECT** the **Delete** pushbutton.

**Note:** You cannot delete the last remaining Form Name or the loaded Form Name. To rename the last defined form, you must use the **New Form...** pushbutton to add a new Form Name, and then delete the old Form Name.

6. To **define** a new form, do the following:
  - a. **SELECT** the **New Form...** pushbutton.
  - b. Use the keyboard to enter the name you choose for the new form.
  - c. **SELECT** the keyboard **OK** pushbutton.
  - d. The new form is added to the list and is initially assigned the same values as the previous form.
  - e. To change these values, see the next step.
7. To **change** a form definition, do the following:
  - a. **SELECT** the form you want to change. The current definition appears.
  - b. **SELECT** the field you want to change. You see either a pop-up window or a keypad window.
  - c. **SELECT** the new value you want from the pop-up window, or enter data on the keypad window and **SELECT** the **OK** pushbutton.



### Setting the Preheat Platen Temperature:

The **Preheat** selection in the **Forms Characteristics** box allows you to adjust the temperature of the preheat platen for optimum fusing of different types of forms, such as labels or heavy-stock forms. The default temperature is 80°C, which is acceptable for regular forms.

If you are defining a form that requires a preheat platen temperature above or below 80°C, you can enter another temperature in increments of 5°; that is, you can enter temperatures such as 70°, 75°, 85° or 90°C. The minimum temperature you can set is 45°C; the maximum temperature you can set is 100°C.

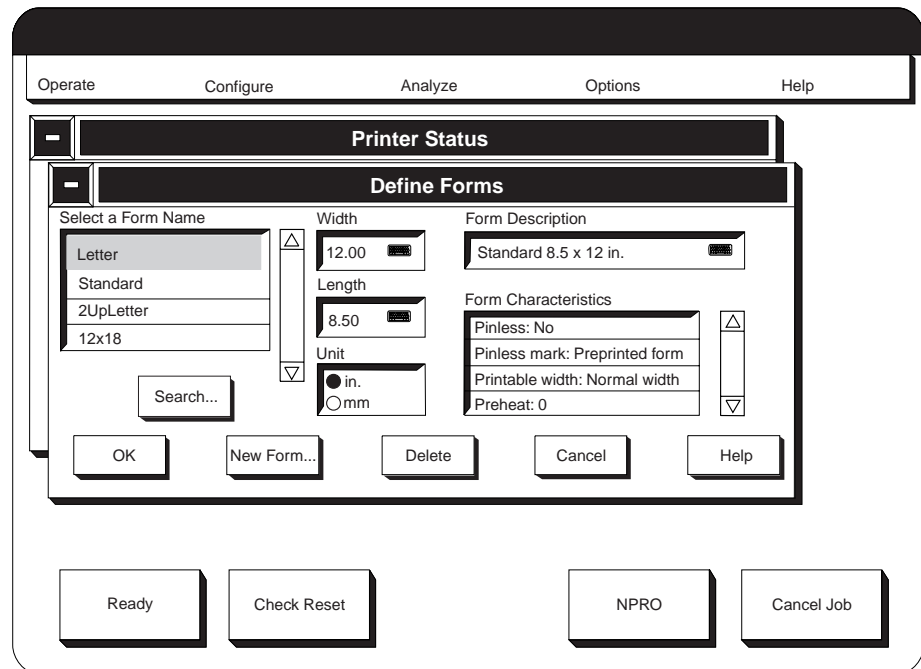

- d. To set or change the preheat platen temperature, do the following:
- **SELECT** the **Preheat** field. A keypad window appears.
  - To use the *default* temperature, enter **0** (zero) on the keypad and **SELECT** the **OK** pushbutton.
- Note:** The default temperature is set under the **Configure Printer** menu.
- To use a different temperature, enter a number between 45 and 100°C in increments of 5 degrees (for example, 50, 55 or 60). **SELECT** the **OK** pushbutton.
- e. When you finish making all changes to forms, **SELECT** the **OK** pushbutton on the **Define Forms** window.

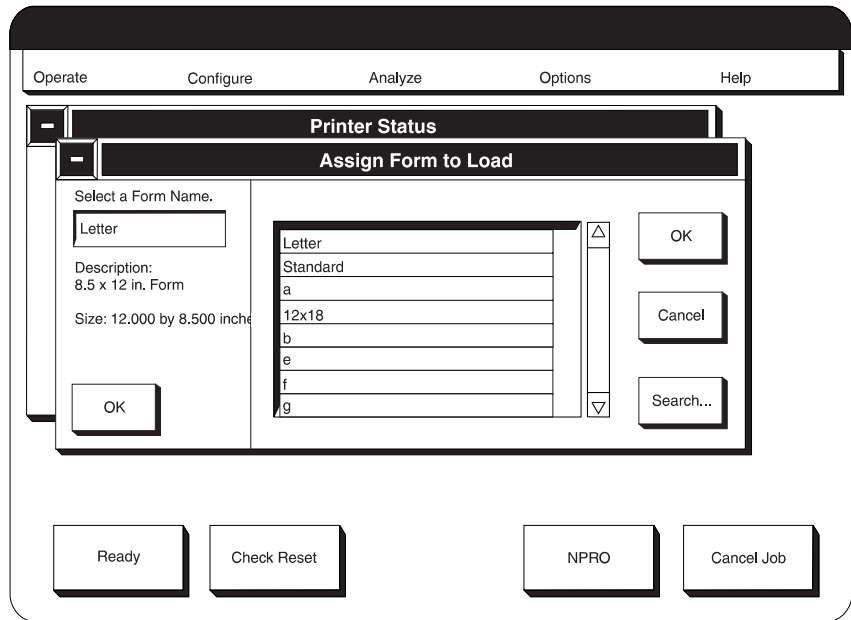

The forms are then available for the *Assign Forms to Load* window.

**Notes:**

1. For form width, specify the total physical width by including the 0.5 inch tractor hole carrier strips on both sides of the form.

For Models ED1/ED2, the following form widths are allowed:

- Dual Simplex Mode: 204 to 457 mm (8.0 to 18.0 in.)
- Duplex Mode: 229 to 457 mm (9.0 to 18.0 in.).

For Model ES1, the following form widths are allowed: 204 to 457 mm (8.0 to 18.0 in.).

Specify the width in millimeters or inches. If you use millimeters, do not use a decimal point. If you use inches, fractions must use a decimal point (enter 13½ as 13.5).

2. For length, specify the length of the form in the process direction (parallel to the tractor holes). You can specify length in millimeters or inches and in lengths from 77 to 432 mm (3 to 17 in.).

Specify the length either in inches to two decimal places or in millimeters as a whole number. The printer rounds the length you enter to the nearest one-sixth inch, and displays it on the screen.

For related information, see “Appendix A. Valid Form Lengths in Inches” on page 291.

# Duplex Configuration Worksheet

Table 24. Configuration Worksheet – Duplex Models

Item	Available Values	Selected Values		
		Duplex	Dual Simplex	
			Printer 1	Printer 2
<b>MESSAGE DISPLAY LANGUAGE:</b>	<ul style="list-style-type: none"> <li>• US English</li> <li>• Spanish</li> <li>• French</li> <li>• German</li> <li>• Japanese</li> <li>• Italian</li> <li>• Brazilian Portuguese</li> <li>• Chinese Simplified</li> <li>• Chinese Traditional</li> </ul>			
<b>PRINTER CONFIGURATION:</b>				
Printer Mode	Duplex / Simplex			
Auto Start	Yes / No			
PQE boldness for printer 1	100% <b>Note:</b> This value must not be changed.	N/A	N/A	N/A
PQE boldness for printer 2	100% <b>Note:</b> This value must not be changed.	N/A	N/A	N/A
Printer 1 Counter	(CE Change Only) 0 to 2 000 000 000	N/A	N/A	N/A
Printer 2 Counter	(CE Change Only) 0 to 2 000 000 000	N/A	N/A	N/A
Printhead resolution (not all values are supported on all printers)	<ul style="list-style-type: none"> <li>• 480 DPI</li> <li>• 600 DPI</li> <li>• 480/600 DPI</li> </ul>			
IPDS Resolution	<ul style="list-style-type: none"> <li>• Automatic</li> <li>• 240 DPI</li> <li>• 300 DPI</li> <li>• 600 DPI</li> </ul>			
Font Enhancement (Single-Byte Font / Double-Byte Font)	Yes / No			
Jam Recovery Type	<ul style="list-style-type: none"> <li>• Use Normal Jam Repositioning</li> <li>• Suppress MICR Jam Repositioning</li> <li>• Suppress All Jam Repositioning</li> </ul>			
Font Usage	Low / Medium / High			
Page Segment Usage	Low / Medium / High			
Overlay Usage	Low / Medium / High			

Table 24. Configuration Worksheet – Duplex Models (continued)

Item	Available Values	Selected Values		
		Duplex	Dual Simplex	
			Printer 1	Printer 2
Overlay Cache	Yes / No			
Input Buffer Size	Low / Medium / High			
Output Buffer Size	Low / Medium / High			
Direct Attach	Yes / No			
NPRO Length	0 to 1200 inches			
Auto NPRO at EOF	Yes / No			
Jam Recovery Point Distance	0 to 500 inches			
Form Feed Length (Duplex Mode Only)	17 to 250 inches		N/A	N/A
Length of Forms Between Transfer Points (Duplex Mode Only)	150 to 800 inches		N/A	N/A
Front Sheet Sequence (Duplex Mode Only)	Front First / Front Second		N/A	N/A
Verification Marks (Duplex Mode Only)	Yes / No		N/A	N/A
Logical Page Increment	0 to 20 pels			
Clear Memory for Security	Yes / No			
Screen Saver Timeout	0 to 60 minutes			
Alarm Suppression	Yes / No			
Fuser Inactivity Timer	0 to 9 hours			
Eject to Front Facing	Yes / No			
Form Definition Order	Yes / No			
Stacker Enabled	Yes / No			
Cut Sheet Emulation	<ul style="list-style-type: none"> <li>• None</li> <li>• Normal Left-to-Right</li> <li>• Normal Right-to-Left</li> <li>• Inverted Left-to-Right</li> <li>• Inverted Right-to-Left</li> </ul>			
BTS Installed	Yes / No			
BTS Enabled	Yes / No			
Offsetter Installed	Yes / No			
Offsetter Enabled	Yes / No			
Offset on Mark Forms	Yes / No			
3130 Bar Code Compatibility	Yes / No			
Printer Preheat Temperature	45 to 100°C			
Scan Factory Adjust for Printer 1	(CE Change Only)	N/A	N/A	N/A
Process Factory Adjust for Printer 1	(CE Change Only)	N/A	N/A	N/A
Scan Factory Adjust for Printer 2	(CE Change Only)	N/A	N/A	N/A
Process Factory Adjust for Printer 2	(CE Change Only)	N/A	N/A	N/A

Table 24. Configuration Worksheet – Duplex Models (continued)

Item	Available Values	Selected Values		
		Duplex	Dual Simplex	
			Printer 1	Printer 2
Beam 1 Offset Adjustment for Printer 1	(CE Change Only) 0.0 to 15.9	N/A	N/A	N/A
Beam 2 Offset Adjustment for Printer 1	(CE Change Only) 0.0 to 15.9	N/A	N/A	N/A
Beam 3 Offset Adjustment for Printer 1	(CE Change Only) 0.0 to 15.9	N/A	N/A	N/A
Beam 4 Offset Adjustment for Printer 1	(CE Change Only) 0.0 to 15.9	N/A	N/A	N/A
Beam 5 Offset Adjustment for Printer 1	(CE Change Only) 0.0 to 15.9	N/A	N/A	N/A
Beam 1 Offset Adjustment for Printer 2	(CE Change Only) 0.0 to 15.9	N/A	N/A	N/A
Beam 2 Offset Adjustment for Printer 2	(CE Change Only) 0.0 to 15.9	N/A	N/A	N/A
Beam 3 Offset Adjustment for Printer 2	(CE Change Only) 0.0 to 15.9	N/A	N/A	N/A
Beam 4 Offset Adjustment for Printer 2	(CE Change Only) 0.0 to 15.9	N/A	N/A	N/A
Beam 5 Offset Adjustment for Printer 2	(CE Change Only) 0.0 to 15.9	N/A	N/A	N/A
Machine Sequence for Printer 1	(CE change on initial configuration only)	N/A	N/A	N/A
Manufacturing Plant for Printer 1	(CE change on initial configuration only)	N/A	N/A	N/A
Machine Sequence for Printer 2	(CE change on initial configuration only)	N/A	N/A	N/A
Manufacturing Plant for Printer 2	(CE change on initial configuration only)	N/A	N/A	N/A
Date and Time	(CE Change Only)	N/A	N/A	N/A
<b>HOST ATTACHMENTS CONFIGURATION:</b>				
<b>Parallel Channel Attachment:</b>				
Parallel Link A Installed	Yes / No			
Parallel Link B Installed	Yes / No			
Device Address	00 to FF			
Second Channel	Static / Dynamic			
Data Transfer Protocol	Interlocked / Data Streaming			
Data Streaming Rate	1.9 / 2.7 / 3.4 / 4.5 MB/sec			
Card 1 Slot Position	6 / 8 / Not Installed	N/A	N/A	N/A
Card 2 Slot Position	6 / 8 / Not Installed	N/A	N/A	N/A
<b>ESCON Channel:</b>				
ESCON Link A Installed	Yes / No			
ESCON Link B Installed	Yes / No			

Table 24. Configuration Worksheet – Duplex Models (continued)

Item	Available Values	Selected Values		
		Duplex	Dual Simplex	
			Printer 1	Printer 2
Device Address	00 to FF			
Multi-host Environmental Flag	True / False			
Card 1 Slot Position	6 / 8 / Not Installed	N/A	N/A	N/A
Card 2 Slot Position	6 / 8 / Not Installed	N/A	N/A	N/A
<b>Token Ring TCP/IP Configuration:</b>				
Installed	Yes/ No			
TCP Port	5001 to 65536			
IP Address	X.X.X.X where X ≤ 255			
Subnet Mask	X.X.X.X where X ≤ 255			
Default Gateway Address	X.X.X.X where X ≤ 255			
MTU Size	60 to 4096			
Hardware address	Cannot be changed	N/A	N/A	N/A
Alternate address	X'0' to X'FFFFFFFFFFFF'			
Ring Speed	4 or 16			
Confine Broadcast	Yes/ No			
<b>Ethernet TCP/IP Configuration:</b>				
Installed	Yes/ No			
TCP Port	5001 to 65536			
IP Address	X.X.X.X where X ≤ 255			
Subnet Mask	X.X.X.X where X ≤ 255			
Default Gateway Address	X.X.X.X where X ≤ 255			
Standard MTU Size	60 to 1500			
IEEE8023 MTU Size	60 to 1492			
Ethernet Type	Standard or IEEE8023			
Hardware address	Cannot be changed	N/A	N/A	N/A
Alternate address	X'0' to X'FFFFFFFFFFFF'			
Cable type	10Base2 or 10Base5			
<b>FDDI TCP/IP Configuration:</b>				
Installed	Yes / No			
TCP Port	5001 to 65536			
IP Address	X.X.X.X where X ≤ 255			
Subnet Mask	X.X.X.X where X ≤ 255			
Default Gateway Address	X.X.X.X where X ≤ 255			
MTU Size	256 to 4352			
Hardware address	Cannot be changed	N/A	N/A	N/A
Alternate address	X'0' to X'FFFFFFFFFFFF'			
Confine Broadcast	Yes / No			

Table 24. Configuration Worksheet – Duplex Models (continued)

Item	Available Values	Selected Values		
		Duplex	Dual Simplex	
			Printer 1	Printer 2
<b>PREPROCESSING/POSTPROCESSING INTERFACE CONFIGURATIONS:</b>				
<i>DEVICE Number</i> _____				
Printer Number	1 / 2		N/A	N/A
Port Number	1 / 2 / 3			
Enabled	Yes / No			
Name	1 to 12 alphanumeric characters (including spaces)			
Type	<ul style="list-style-type: none"> <li>• Coupled Preprocessor</li> <li>• Coupled Postprocessor</li> <li>• Advanced Postprocessor - MICR</li> <li>• Advanced Postprocessor - SMM (Select Medium Modification)</li> </ul>			
<b>Characteristics:</b>				
Pre/Postprocessor Extended NPRO:	0 to 800 inches			
Pre/Postprocessor Busy Timer:	1 to 999 seconds			
Postprocessor Tag Type:	<ul style="list-style-type: none"> <li>• Coupled</li> <li>• RSI Compatible</li> </ul>			
Distance to Postprocessor	<ul style="list-style-type: none"> <li>• 24 to 800 inches</li> <li>• 24 to 1200 inches</li> </ul>			
Postprocessor Error Page Stop	0 to 50 pages			
Postprocessor Verify Alignment Page Stop	0 to 5000 pages			
Pre/Postprocessor Baud Rate in Kbps	19.2 or 62.5			
<i>DEVICE Number</i> _____				
Printer Number	1 / 2		N/A	N/A
Port Number	1 / 2 / 3			
Enabled	Yes / No			
Name	1 to 12 alphanumeric characters (including spaces)			
Type	<ul style="list-style-type: none"> <li>• Coupled Preprocessor</li> <li>• Coupled Postprocessor</li> <li>• Advanced Postprocessor - MICR</li> <li>• Advanced Postprocessor - SMM (Select Medium Modification)</li> </ul>			
<b>Characteristics:</b>				
Pre/Postprocessor Extended NPRO:	0 to 800 inches			

Table 24. Configuration Worksheet – Duplex Models (continued)

Item	Available Values	Selected Values		
		Duplex	Dual Simplex	
			Printer 1	Printer 2
Pre/Postprocessor Busy Timer:	1 to 999 seconds			
Postprocessor Tag Type:	<ul style="list-style-type: none"> <li>• Coupled</li> <li>• RSI Compatible</li> <li>• Advanced</li> </ul>			
Distance to Postprocessor	<ul style="list-style-type: none"> <li>• 24 to 800 inches</li> <li>• 24 to 1200 inches</li> </ul>			
Postprocessor Error Page Stop	0 to 50 pages			
Postprocessor Verify Alignment Page Stop	0 to 5000 pages			
Pre/Postprocessor Baud Rate in Kbps	19.2 or 62.5			
<i>DEVICE Number</i> _____				
Printer Number	1 / 2		N/A	N/A
Port Number	1 / 2 / 3			
Enabled	Yes / No			
Name	1 to 12 alphanumeric characters (including spaces)			
Type	<ul style="list-style-type: none"> <li>• Coupled Preprocessor</li> <li>• Coupled Postprocessor</li> <li>• Advanced Postprocessor - MICR</li> <li>• Advanced Postprocessor - SMM (Select Medium Modification)</li> </ul>			
<b>Characteristics:</b>				
Pre/Postprocessor Extended NPRO:	0 to 800 inches			
Pre/Postprocessor Busy Timer:	1 to 999 seconds			
Postprocessor Tag Type:	<ul style="list-style-type: none"> <li>• Coupled</li> <li>• RSI Compatible</li> <li>• Advanced</li> </ul>			
Distance to Postprocessor	<ul style="list-style-type: none"> <li>• 24 to 800 inches</li> <li>• 24 to 1200 inches</li> </ul>			
Postprocessor Error Page Stop	0 to 50 pages			
Postprocessor Verify Alignment Page Stop	0 to 5000 pages			
Pre/Postprocessor Baud Rate in Kbps	19.2 or 62.5			
<i>DEVICE Number</i> _____				
Printer Number	1 / 2		N/A	N/A
Port Number	1 / 2 / 3			



Table 24. Configuration Worksheet – Duplex Models (continued)

Item	Available Values	Selected Values		
		Duplex	Dual Simplex	
			Printer 1	Printer 2
Enabled	Yes / No			
Name	1 to 12 alphanumeric characters (including spaces)			
Type	<ul style="list-style-type: none"> <li>• Coupled Preprocessor</li> <li>• Coupled Postprocessor</li> <li>• Advanced Postprocessor - MICR</li> <li>• Advanced Postprocessor - SMM (Select Medium Modification)</li> </ul>			
<b>Characteristics:</b>				
Pre/Postprocessor Extended NPRO:	0 to 800 inches			
Pre/Postprocessor Busy Timer:	1 to 999 seconds			
Postprocessor Tag Type:	<ul style="list-style-type: none"> <li>• Coupled</li> <li>• RSI Compatible</li> <li>• Advanced</li> </ul>			
Distance to Postprocessor	<ul style="list-style-type: none"> <li>• 24 to 800 inches</li> <li>• 24 to 1200 inches</li> </ul>			
Postprocessor Error Page Stop	0 to 50 pages			
Postprocessor Verify Alignment Page Stop	0 to 5000 pages			
Pre/Postprocessor Baud Rate in Kbps	19.2 or 62.5			

## Simplex Configuration Worksheet

Table 25. Configuration Worksheet – Simplex Model

Item	Available Values	Selected Value
<b>MESSAGE DISPLAY LANGUAGE:</b>	<ul style="list-style-type: none"> <li>• US English</li> <li>• Spanish</li> <li>• French</li> <li>• German</li> <li>• Japanese</li> <li>• Italian</li> <li>• Brazilian Portuguese</li> <li>• Chinese Simplified</li> <li>• Chinese Traditional</li> </ul>	
<b>CONFIGURE PRINTER:</b>		
Auto Start	Yes / No	
PQE boldness	100%	This value must not be changed.
Printer Counter	(CE Change Only) 0 to 2 000 000 000	N/A
Printhead resolution (not all values are supported on all printers)	<ul style="list-style-type: none"> <li>• 480 DPI</li> <li>• 600 DPI</li> <li>• 480/600 DPI</li> </ul>	
IPDS Resolution	<ul style="list-style-type: none"> <li>• Automatic</li> <li>• 240 DPI</li> <li>• 300 DPI</li> <li>• 600 DPI</li> </ul>	
Font Enhancement (Single-Byte / Double-Byte Font)	Yes / No	
Jam Recovery Type	<ul style="list-style-type: none"> <li>• Use Normal Jam Repositioning</li> <li>• Suppress MICR Jam Repositioning</li> <li>• Suppress All Jam Repositioning</li> </ul>	
Font Usage	Low / Medium / High	
Page Segment Usage	Low / Medium / High	
Overlay Usage	Low / Medium / High	
Overlay Cache	Yes / No	
Input Buffer Size	Low / Medium / High	
Output Buffer Size	Low / Medium / High	
Direct Attach	Yes / No	
NPRO Length	0 to 1200 inches	
Auto NPRO at EOF	Yes / No	
Jam Recovery Point Distance	0 to 500 inches	
Logical Page Increment	0 to 20 pels	
Clear Memory for Security	Yes / No	

Table 25. Configuration Worksheet – Simplex Model (continued)

Item	Available Values	Selected Value
Screen Saver Timeout	0 to 60 minutes	
Alarm Suppression	Yes / No	
Fuser Inactivity Timer	0 to 9 hours	
Eject to Front Facing	Yes / No	
Form definition order	Yes / No	
Stacker Enabled	Yes / No	
Cut sheet emulation	<ul style="list-style-type: none"> <li>• None</li> <li>• Normal Left-to-Right</li> <li>• Normal Right-to-Left</li> <li>• Inverted Left-to-Right</li> <li>• Inverted Right-to-Left</li> </ul>	
BTS Installed	Yes / No	
BTS Enabled	Yes / No	
Offsetter Installed	Yes / No	
Offsetter Enabled	Yes / No	
Offset on Mark Forms	Yes / No	
3130 Bar Code Compatibility	Yes / No	
Printer Preheat Temperature	45 to 100°C	
Scan Factory Adjust	(CE Change Only)	N/A
Process Factory Adjust	(CE Change Only)	N/A
Beam 1 Offset	(CE Change Only) 0.0 to 15.9	N/A
Beam 2 Offset	(CE Change Only) 0.0 to 15.9	N/A
Beam 3 Offset	(CE Change Only) 0.0 to 15.9	N/A
Beam 4 Offset	(CE Change Only) 0.0 to 15.9	N/A
Beam 5 Offset	(CE Change Only) 0.0 to 15.9	N/A
Machine Sequence	(CE Change Only)	N/A
Manufacturing Plant	(CE Change Only)	N/A
Date and Time	(CE Change Only)	N/A
<b>HOST ATTACHMENTS CONFIGURATION:</b>		
<b>Parallel Channel:</b>		
Parallel Link A Installed	Yes / No	
Parallel Link B Installed	Yes / No	
Device Address	00 to FF (hexadecimal)	
Second Channel	Static / Dynamic	
Data Transfer Protocol	Interlocked / Data Streaming	
Data Streaming Rate	1.9 / 2.7 / 3.4 / 4.5MB /sec	
Card 1 Slot Position	2 / 4 / Not Installed	Automatically set at power on, cannot be changed.
Card 2 Slot Position	2 / 4 / Not Installed	Automatically set at power on, cannot be changed.
<b>ESCON Channel:</b>		

Table 25. Configuration Worksheet – Simplex Model (continued)

Item	Available Values	Selected Value
ESCON Link A Installed	Yes / No	
ESCON Link B Installed	Yes / No	
Device Address	00 to FF (Hexadecimal)	
Multi-host Environmental Flag	True / False	
Card 1 Slot Position	2 / 4 / Not Installed	Automatically set at power on, cannot be changed.
Card 2 Slot Position	2 / 4 / Not Installed	Automatically set at power on, cannot be changed.
<b>Token Ring TCP/IP Configuration:</b>		
Installed	Yes / No	
TCP Port	5001 to 65536	
IP Address	X.X.X.X where X ≤ 255	
Subnet Mask	X.X.X.X where X ≤ 255	
Default Gateway Address	X.X.X.X where X ≤ 255	
MTU Size	60 to 4096	
Hardware address	Cannot be changed	
Alternate address	X'0' to X'FFFFFFFFFFFF'	
Ring Speed	4 or 16	
Confine Broadcast	Yes / No	
<b>Ethernet TCP/IP Configuration:</b>		
Installed	Yes / No	
TCP Port	5001 to 65536	
IP Address	X.X.X.X where X ≤ 255	
Subnet Mask	X.X.X.X where X ≤ 255	
Default Gateway Address	X.X.X.X where X ≤ 255	
Standard MTU Size	60 to 1500	
IEEE8023 MTU Size	60 to 1492	
Ethernet Type	Standard or IEEE8023	
Hardware address	Cannot be changed	
Alternate address	X'0' to X'FFFFFFFFFFFF'	
Cable type	10Base2 or 10Base5	
<b>PREPROCESSING/POSTPROCESSING INTERFACE CONFIGURATIONS:</b>		
<i>DEVICE Number</i> _____		
Port Number	1 / 2 / 3	
Enabled	Yes / No	
Name	1 to 12 alphanumeric characters (including spaces)	

Table 25. Configuration Worksheet – Simplex Model (continued)

Item	Available Values	Selected Value
Type	<ul style="list-style-type: none"> <li>• Coupled Preprocessor</li> <li>• Coupled Postprocessor</li> <li>• Advanced Postprocessor - MICR</li> <li>• Advanced Postprocessor - SMM (Select Medium Modification)</li> </ul>	
<b>Characteristics:</b>		
Pre/Postprocessor Extended NPRO:	0 to 800 inches	
Pre/Postprocessor Busy Timer:	1 to 999 seconds	
Postprocessor Tag Type:	<ul style="list-style-type: none"> <li>• Coupled</li> <li>• RSI Compatible</li> </ul>	
Distance to Postprocessor	<ul style="list-style-type: none"> <li>• 24 to 800 inches</li> <li>• 24 to 1200 inches</li> </ul>	
Postprocessor Error Page Stop	0 to 50 pages	
Postprocessor Verify Alignment Page Stop	0 to 5000 pages	
Pre/Postprocessor Baud Rate in Kbps	19.2 or 62.5	
<i>DEVICE Number</i> _____		
Port Number	1 / 2 / 3	
Enabled	Yes / No	
Name	1 to 12 alphanumeric characters (including spaces)	
Type	<ul style="list-style-type: none"> <li>• Coupled Preprocessor</li> <li>• Coupled Postprocessor</li> <li>• Advanced Postprocessor - MICR</li> <li>• Advanced Postprocessor - SMM (Select Medium Modification)</li> </ul>	
<b>Characteristics:</b>		
Pre/Postprocessor Extended NPRO:	0 to 800 inches	
Pre/Postprocessor Busy Timer:	1 to 999 seconds	
Postprocessor Tag Type:	<ul style="list-style-type: none"> <li>• Coupled</li> <li>• RSI Compatible</li> <li>• Advanced</li> </ul>	
Distance to Postprocessor	<ul style="list-style-type: none"> <li>• 24 to 800 inches</li> <li>• 24 to 1200 inches</li> </ul>	
Postprocessor Error Page Stop	0 to 50 pages	
Postprocessor Verify Alignment Page Stop	0 to 5000 pages	
Pre/Postprocessor Baud Rate in Kbps	19.2 or 62.5	
<i>DEVICE Number</i> _____		
Port Number	1 / 2 / 3	
Enabled	Yes / No	

Table 25. Configuration Worksheet – Simplex Model (continued)

Item	Available Values	Selected Value
Name	1 to 12 alphanumeric characters (including spaces)	
Type	<ul style="list-style-type: none"> <li>• Coupled Preprocessor</li> <li>• Coupled Postprocessor</li> <li>• Advanced Postprocessor - MICR</li> <li>• Advanced Postprocessor - SMM (Select Medium Modification)</li> </ul>	
<b>Characteristics:</b>		
Pre/Postprocessor Extended NPRO:	0 to 800 inches	
Pre/Postprocessor Busy Timer:	1 to 999 seconds	
Postprocessor Tag Type:	<ul style="list-style-type: none"> <li>• Coupled</li> <li>• RSI Compatible</li> </ul>	
Distance to Postprocessor	<ul style="list-style-type: none"> <li>• 24 to 800 inches</li> <li>• 24 to 1200 inches</li> </ul>	
Postprocessor Error Page Stop	0 to 50 pages	
Postprocessor Verify Alignment Page Stop	0 to 5000 pages	
Pre/Postprocessor Baud Rate in Kbps	19.2 or 62.5	
<b>DEVICE Number</b> _____		
Port Number	1 / 2 / 3	
Enabled	Yes / No	
Name	1 to 12 alphanumeric characters (including spaces)	
Type	<ul style="list-style-type: none"> <li>• Coupled Preprocessor</li> <li>• Coupled Postprocessor</li> <li>• Advanced Postprocessor - MICR</li> <li>• Advanced Postprocessor - SMM (Select Medium Modification)</li> </ul>	
<b>Characteristics:</b>		
Pre/Postprocessor Extended NPRO:	0 to 800 inches	
Pre/Postprocessor Busy Timer:	1 to 999 seconds	
Postprocessor Tag Type:	<ul style="list-style-type: none"> <li>• Coupled</li> <li>• RSI Compatible</li> </ul>	
Distance to Postprocessor	<ul style="list-style-type: none"> <li>• 24 to 800 inches</li> <li>• 24 to 1200 inches</li> </ul>	
Postprocessor Error Page Stop	0 to 50 pages	
Postprocessor Verify Alignment Page Stop	0 to 5000 pages	
Pre/Postprocessor Baud Rate in Kbps	19.2 or 62.5	

---

## Form Identification Worksheets

Use the “Form Identification Worksheet” on page 264 to record form identification names with their associated lengths, widths, description, and characteristics. You can define up to 1024 different forms for duplex and simplex modes and 1024 additional forms for each printer in dual simplex mode, for a total of 3072 form definitions for the complete system. Make copies of the worksheets as necessary.

You may also find it helpful to make notes about loading techniques, adjusting print values, or other information that may be particular to certain forms.

## Form Identification Worksheet

Table 26. Form Identification Worksheet

Form Number:	Definition	With This Value:	Notes:
	Name Width (in millimeters or inches) Length (in millimeters or inches) Description Preheat temperature	_____ _____ _____ _____	
	Name Width (in millimeters or inches) Length (in millimeters or inches) Description Preheat temperature	_____ _____ _____ _____	
	Name Width (in millimeters or inches) Length (in millimeters or inches) Description Preheat temperature	_____ _____ _____ _____	
	Name Width (in millimeters or inches) Length (in millimeters or inches) Description Preheat temperature	_____ _____ _____ _____	
	Name Width (in millimeters or inches) Length (in millimeters or inches) Description Preheat temperature	_____ _____ _____ _____	
	Name Width (in millimeters or inches) Length (in millimeters or inches) Description Preheat temperature	_____ _____ _____ _____	
	Name Width (in millimeters or inches) Length (in millimeters or inches) Description Preheat temperature	_____ _____ _____ _____	
	Name Width (in millimeters or inches) Length (in millimeters or inches) Description Preheat temperature	_____ _____ _____ _____	
	Name Width (in millimeters or inches) Length (in millimeters or inches) Description Preheat temperature	_____ _____ _____ _____	
	Name Width (in millimeters or inches) Length (in millimeters or inches) Description Preheat temperature	_____ _____ _____ _____	



---

## Chapter 9. Print Quality and Problem Solving

Print Quality Problems . . . . .	266	Problem Solving Tips and Suggested Actions . . .	269
Sudden Failures . . . . .	268		

This chapter contains information for understanding and solving unusual problems that may occur when you use the printer. The first part of this chapter describes *Print Quality* problems, and the second part of this chapter describes *Problem Solving* tips and suggested actions.

## Print Quality Problems

Many print quality problems are directly related to the kind of forms that are being used and the application that is being processed. If a particular form or application regularly produces unsatisfactory output, refer the application owner to the *Forms Design Reference for Continuous Forms Advanced Function Printers*, G544-3921. This publication contains detailed information about selecting forms and designing applications for use with continuous forms printers.

Table 27 describes possible print quality problems and suggests actions that may correct the symptoms.

Table 27. Print Quality Symptom Table

Symptom	Action
Repeating spot patterns	<ul style="list-style-type: none"> <li>• Clean the printer and the oiler belt. See “Cleaning the Printer” on page 88 and “Cleaning the Oiler Belt” on page 86.</li> <li>• If you have been running labels, print a test job on plain paper forms to remove any adhesive residue that the labels may have left in the printer.</li> </ul>
Print is too dark or characters appear too wide.	Press the <b>Lighter Contrast Control</b> key on the printer control panel.
In duplex printing mode, there is a noticeable difference in the printing contrast between the front and back sides of the form, even though the Contrast Switch setting is set the same on both printers.	It is normal for printing contrast to vary between printers. Adjust the Contrast setting on the printer control panel of both printers to balance the contrast between the printers.
Blank spots (voids) or light areas appear near perforations.	<p>This problem is usually related to forms design, and it cannot be corrected by adjusting the printer.</p> <p>The following restrictions, copied from the <i>Forms Design Reference for Continuous Forms Advanced Function Printers</i>, G544-3921 must be maintained.</p> <p>Print quality may be poor near fold perforations, an internal perforation, or any cut in the form. To ensure correct operation and print quality, maintain the following distances:</p> <ul style="list-style-type: none"> <li>• From non-folding and internal perforations: 1.27 mm (0.05 in.)</li> <li>• From folding perforations: 1.27 mm (0.05 in.)</li> <li>• From binder holes and cuts: 2.54 mm (0.1 in.)</li> </ul> <p>If the specified distance from the page perforations is not being maintained, refer the application owner to the <i>Forms Design Reference for Continuous Forms Advanced Function Printers</i>, G544-3921.</p>
Loss of edge definition or lighter print contrast (boldness) at the trailing edge of bar codes, shaded or solid fill areas, or formatted bold text characters.	The problem can be reduced or eliminated by increasing the <b>Contrast</b> switch setting on the printer control panel. Remember to adjust the contrast setting on both printers when they are in duplex mode. This balances the contrast between the front and back of the forms.

Table 27. Print Quality Symptom Table (continued)

Symptom	Action
Blank spots (voids) or light areas not near perforations	<ul style="list-style-type: none"> <li>• Ensure that the forms are smooth and flat. Feel the forms, especially near the perforation. If you find lumps, bumps, or wrinkles, load another box of forms. This kind of problem can be caused by storing forms in a poor environment (for example, high humidity).</li> <li>• If you have been running labels, print a test job on plain paper forms to remove any adhesive residue that the labels may have left in the printer.</li> <li>• Clean the coronas. See step 24 on page 95 in “Cleaning the Printer”.</li> <li>• Press the <b>Darker Contrast Control</b> key on the printer control panel.</li> <li>• If the void or light area is in the shape of an adhesive label, call your service representative. See “Service Call Procedure” on page 13.</li> </ul>
Print has white streaks.	<ul style="list-style-type: none"> <li>• Clean the coronas. See step 24 on page 95 in “Cleaning the Printer”. If necessary, remove the coronas and look for forms chads in the wire or corona housing. Be careful not to touch the wire with your hands. See “Cleaning the Printer” on page 88.</li> </ul>
Print is too light.	<ul style="list-style-type: none"> <li>• Press the <b>Darker Contrast Control</b> key on the printer control panel.</li> <li>• Clean the coronas. See step 24 on page 95 in “Cleaning the Printer” and step 10 on page 90 in “Cleaning the Printer”.</li> <li>• If you opened and closed the developer drain <i>without</i> replacing the developer mix, replace the developer mix now. Opening the drain resets the developer mix usage timer; this could result in the developer mix being used beyond its normal life and result in immediate print quality problems. See “Changing the Developer Mix” on page 191.</li> </ul>
Print rubs off easily.	<ul style="list-style-type: none"> <li>• If print rubs off solid fill areas (logos, bar codes) on the form, press the <b>Lighter Contrast Control</b> key setting on the printer control panel until fuse grade is acceptable. Remember to adjust the contrast setting on both printers, when they are in duplex mode. This balances the contrast between the front and back of the forms.</li> <li>• Ensure that the <b>Forms Select</b> switch is set correctly for the forms being used.</li> <li>• Clean the oiler belt. See “Cleaning the Oiler Belt” on page 86.</li> <li>• Ensure that the forms were fused. For example, did you use <b>Forms Feed</b> when you should have used <b>NPRO</b>?</li> <li>• Ensure that the hot roll shield is up.</li> <li>• Load a different box of forms. The forms you are running may be too heavy (more than 160 g/m<sup>2</sup> (42 lb) when running simplex mode, or more than 105 g/m<sup>2</sup> (28 lb) when running duplex mode), or too moist, or have too rough a surface.</li> <li>• Ensure that no adhesive labels are on the hot roll.</li> </ul>
Print is offset (double images).	<ul style="list-style-type: none"> <li>• If you are printing on labels, ensure that the <b>Forms Select</b> switch is set on <b>Plastic</b>.</li> <li>• If you are not printing on labels, try setting the <b>Forms Select</b> switch to <b>23–42lbs. (72–135kg) 83–157g</b>.</li> <li>• Clean the oiler belt. See “Cleaning the Oiler Belt” on page 86.</li> <li>• Ensure that the hot roll shield is up.</li> </ul>
Print is not correctly registered.	<ul style="list-style-type: none"> <li>• Ensure that the print position is adjusted correctly. See “Adjusting the Print Position” on page 68 for more information.</li> <li>• Check forms alignment. See “Checking the Forms Alignment” on page 84.</li> </ul>

Table 27. Print Quality Symptom Table (continued)

Symptom	Action
Dark background or dirty prints	Clean the printer, particularly the coronas and the oiler belt. See "Cleaning the Oiler Belt" on page 86 and "Cleaning the Printer" on page 88.
Dark streaks	Clean the printer, particularly the coronas and the oiler belt. See "Cleaning the Oiler Belt" on page 86 and "Cleaning the Printer" on page 88.
Dark or fuzzy 12 mm (0.5 inch) wide band across width of page (print bloom); characters appear bolder or slightly larger than normal.	This problem may occur at the point where pages stop in the fuser. The problem may also be application-related, and if so, cannot be corrected by adjusting the printer.
Any other print quality problem or any of the above problems that persist after you have followed all of the corrective steps.	Call your service representative. See "Service Call Procedure" on page 13.

---

## Sudden Failures

If your printer has been operating satisfactorily for a reasonable period and then suddenly fails, consider the following questions:

- Is the printer processing a new application?
- Is the printer using new forms?
- Are forms or other supplies being obtained from a new supplier?
- Have the IBM Advanced Function Printing licensed programs been updated?
- Have any changes occurred in the operating system environment?
- Has the printer been recabled or moved?
- Have any configuration items been changed recently?

If the answer to any of these questions is "yes", you may have found the cause of the problem. Work with your system programmer, service representative, or application owner to resolve the situation.

## Problem Solving Tips and Suggested Actions

Table 28 is a summary of some hard-to-classify symptoms, a discussion of the probable cause, and some actions for you to try.

Table 28. Miscellaneous Problems

Symptom	Discussion	Suggested Action
The printer frequently jams during loading.	<p>Loading problems are usually caused by the forms that are being loaded.</p> <p>If a particular form jams frequently, refer the application owner to the <i>Forms Design Reference for Continuous Forms Advanced Function Printers</i>, G544-3921. This book contains detailed information about selecting forms and designing applications for use with a continuous forms printer.</p>	<ul style="list-style-type: none"> <li>• Ensure that the folded or leading edge of the form is not wrinkled or torn.</li> <li>• If the first page is folded under, ensure that the tractor holes line up <i>exactly</i>. If you are using forms with a <math>1/3</math>-inch or <math>2/3</math>-inch increment, ensure that the fold is on a perforation that is centered between tractor holes. This occurs only once every three pages.</li> <li>• If the stack of forms seems to curve (dishing), roll the first form in the opposite direction of the curve, and then unroll it before you put the form on the transfer station lower tractors.</li> </ul>
A message appears repeatedly on the Display Touch Screen window.	None	<ul style="list-style-type: none"> <li>• See “Chapter 10. Responding to Messages” on page 271. Ensure that you have tried all of the actions described in the message.</li> <li>• If the message continues, call your service representative. See “Service Call Procedure” on page 13.</li> </ul>
A status message is displayed for a long time without changing.	Some messages give status about operations that really <i>do</i> take a long time. For example, during a Restart operation the control unit is transferring programs from the hard disk into the control unit memory; it cannot display a new message until those programs are up and running.	<ul style="list-style-type: none"> <li>• Wait at least five minutes before you attempt any recovery action.</li> <li>• If the message does not change and recovery actions fail, use the “Service Call Procedure” on page 13 to contact your service representative.</li> </ul>
The Display Touch Screen monitor is blank, all indicators are off, and the printer is silent.	The printer is not getting any electrical power.	Determine if some or all of your building is experiencing a power outage. If not, use the “Service Call Procedure” on page 13 to contact your service representative.
Some function switches do not respond when pressed.	The printers keep only potentially valid controls (hardware switches and Display Touch Screen pushbuttons) active while operating. For example, when the Display Touch Screen shows READY, only the <b>Stop</b> function is active. You must stop the printer before using any other functions.	If a function key <i>should</i> be active but is not, use the “Service Call Procedure” on page 13 to contact your service representative.
The alarm is sounding.	The audible alarm tone should sound whenever an interruption message appears in a Display Touch Screen window. The intervention light on top of the printer comes on at the same time.	<ul style="list-style-type: none"> <li>• <b>SELECT</b> the <b>Check Reset</b> pushbutton on the interruption window.</li> <li>• If the alarm continues, use the “Service Call Procedure” on page 13 to contact your service representative.</li> </ul>

Table 28. Miscellaneous Problems (continued)

Symptom	Discussion	Suggested Action
The intervention light on top of the printer comes on, but the alarm does not sound.	The alarm volume may be set to a low volume or alarm suppression may be set to Yes in the printer configuration.	Adjust the alarm volume control; see "Adjusting the Volume of the Operator Alert Assembly" on page 74.
Labels stick together in the stacker. Toner from one page sticks to the facing page.	Labels must be processed in simplex mode.	<ul style="list-style-type: none"> <li>• Set the <b>Forms Select</b> switch on the stacker control panel to <b>Plastic</b>.</li> <li>• Reduce the contrast by pressing the <b>Lighter Contrast Control</b> key on the printer control panel.</li> <li>• Print a stack of forms and check to ensure that the problem is resolved.</li> </ul>
The Display Touch Screen <b>Printer Status</b> window shows <b>READY</b> , but the printer does not respond when the host system console operator directs a job to it.	There is probably a problem with the attachment hardware connecting the printer to the controlling computer system, such as the channel is not enabled or cables are not connected.	Work with the system console operator and the system programmer to resolve the problem. Review the questions in "Sudden Failures" on page 268 to see if there have been any changes in the environment that might affect attachment hardware.
The printer starts and stops repeatedly, or the forms move at an irregular speed.	This problem may be related to the application that is being processed, or to the printer configuration. If the printed pages are complex to format; if many transmission errors occur; or if the buffered data commands are issued by the host, the printers must pause while those pages are created in memory.	Work with the system engineer or system programmer to resolve the problem. The <i>Forms Design Reference for Continuous Forms Advanced Function Printers, G544-3921</i> , contains detailed information about selecting forms and designing applications, and may be of use in resolving the problem.
The Display Touch Screen shows <b>END OF FORMS</b> , but forms are present.	Something is preventing the printer from sensing that forms are available. Narrow forms sometimes slide sideways, away from the paper sensor.	<ul style="list-style-type: none"> <li>• Inspect the forms in the forms input area for holes in the printable area.</li> </ul>
Missing data at the rear of the forms (printer right-hand side).	The rear tractor could be out of adjustment.	<ul style="list-style-type: none"> <li>• Ensure that you are using the correct form width for the form ID that was entered.</li> <li>• Ensure that the correct form ID was entered for that form.</li> </ul>

---

## Chapter 10. Responding to Messages

### Chapter Overview

This chapter lists the messages and codes that the printer displays, and it gives information about how to interpret and respond to them. The error types in their order of precedence are:

- “Program Check Messages” on page 272
- “Printer Error Messages” on page 274
- “Out Of Supplies Messages” on page 276
- “Intervention Required Messages” on page 277
- “Status Messages” on page 278.

“Messages with System Reference Codes” on page 280 lists all of the messages that include a system reference code.

## Program Check Messages

Program Check messages show that the internal control unit microcode has detected a problem that may not allow the code to keep running. Program Check messages appear on the Display Touch Screen.

### Soft Program Check

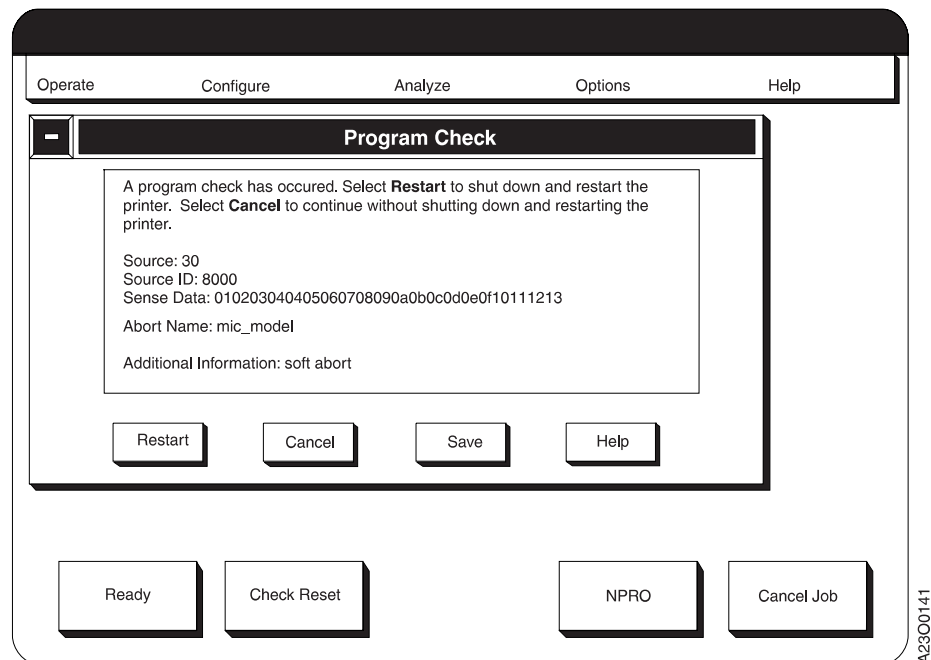

Figure 37. Soft Program Check Window

- **SELECT** the **Save** pushbutton to save all existing trace data to diskette, if desired.
- **SELECT** the **Cancel** pushbutton. If the window is removed, retry the operation in progress when the Program Check condition occurred.
- If the window reappears, **SELECT** the **Restart** pushbutton.
- At the completion of the Restart procedure, retry the operation in progress when the Program Check condition occurred.
- Call for service if the problem continues.



## Hard Program Checks

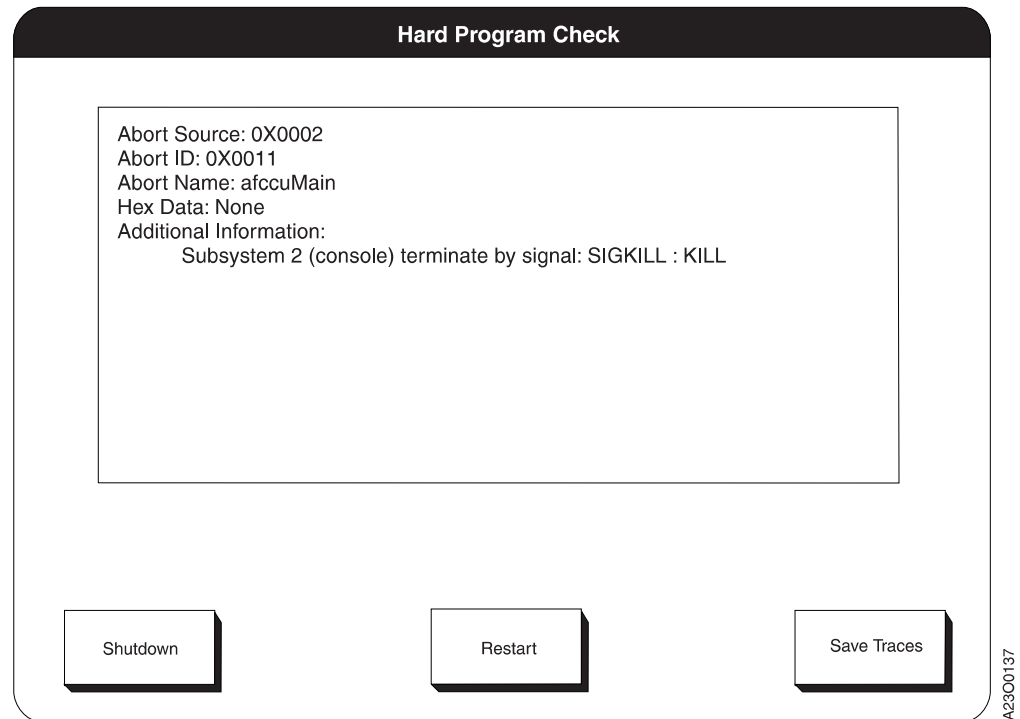

Figure 38. Hard Program Check Window - Normal Operations

- For a Hard Program Check that occurs during either a power on/bring up sequence or normal operations, do the following:
  - **SELECT** the **Save Traces** pushbutton to save all existing trace data to diskette, if desired.
  - **SELECT** the **Restart** pushbutton. If the window does not reappear after the completion of the Restart procedure, retry the operation in progress when the Program Check condition occurred.
  - If the window reappears after the completion of the Restart procedure, **SELECT** the **Shutdown** pushbutton.
  - At the completion of the Shutdown procedure, power off the system.
  - Switch power on to the system.
  - At the completion of the power on sequence, retry the operation in progress when the Program Check condition occurred.
  - Call for service if the problem continues.
- For a Master Program Check occurring during a power on/bring up sequence, do the following:
  - **SELECT** the **Save Traces** pushbutton to save trace data to diskette, if desired.
  - **SELECT** the **Continue** pushbutton.
  - If the window reappears, call for service.

## Printer Error Messages

Printer Error messages show that a serious hardware, microcode, or host interface problem has been detected in a printer or in the control unit. An operator can sometimes, but not always, recover from this problem.

Figure 39 shows a sample **Printer Error** window.

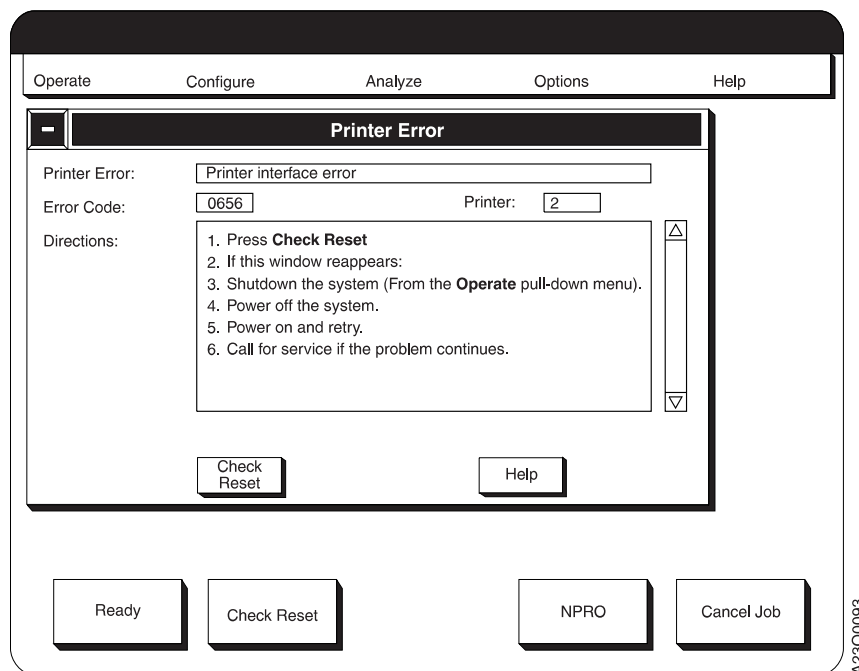

Figure 39. Printer Error Window

This window contains the following:

- A short description of the detected error condition.
- The four-character System Reference Code (SRC), which is used for logging of error conditions.
- An indication of which printer the error occurred on. If the error message is for the control unit, this field is not included on the window.
- A step-by-step recovery procedure, or directions to another source of procedures.
- Function pushbuttons:

### Completed

This pushbutton is included only for error conditions that may be postponed. Select it when you complete all recovery actions.

### Postpone

This pushbutton is included only for error conditions that may be postponed. Select it when you want to postpone error recovery. The message is then listed in the Messages selection list box on the **Printer Status** window, which you can select from the **Operate** pull-down menu.

### Check Reset

This pushbutton is included only for error conditions that you must handle immediately. Select it when you complete all recovery actions.

**Help** This pushbutton is included on all Printer Error windows. Select it to display help information for the panel.

**Notes**

1. Table 30 on page 281 lists all printer error messages.
2. Printer error messages appear in the printer Display Touch Screen area for the printer on which the error occurred.

---

## Out Of Supplies Messages

Out of Supplies messages specify an operator task that needs to be done involving printer supplies. Figure 40 shows a sample **Out of Supplies** window.

*Figure 40. Out of Supplies Window*

This window contains the following:

- The name of the supply and the action that is required.
- An indication of which printer needs attention.
- A step-by-step procedure to follow.
- Function pushbuttons:

**Check Reset**

Informs the control unit that you have completed all actions necessary to replenish the supply item.

For supply actions that may be postponed, this pushbutton allows you to postpone the action and place the printer back into Ready status.

**Help** Displays help information.

**Notes**

- You may be able to temporarily postpone replacing some of the supplies (such as the fuser oil, developer mix, and fine filter). You must replace toner and the toner collector as soon as the out-of-supplies condition occurs. See “Chapter 7. Ordering and Replacing Supplies” on page 175 for more information.
- All Out of Supplies messages appear in the printer Display Touch Screen area for the printer on which the error occurred.
- See Table 30 on page 281 for a list of all messages of this type.

## Intervention Required Messages

Intervention Required messages specify an operator task that you need to do. Figure 41 shows a sample **Intervention Required** window.

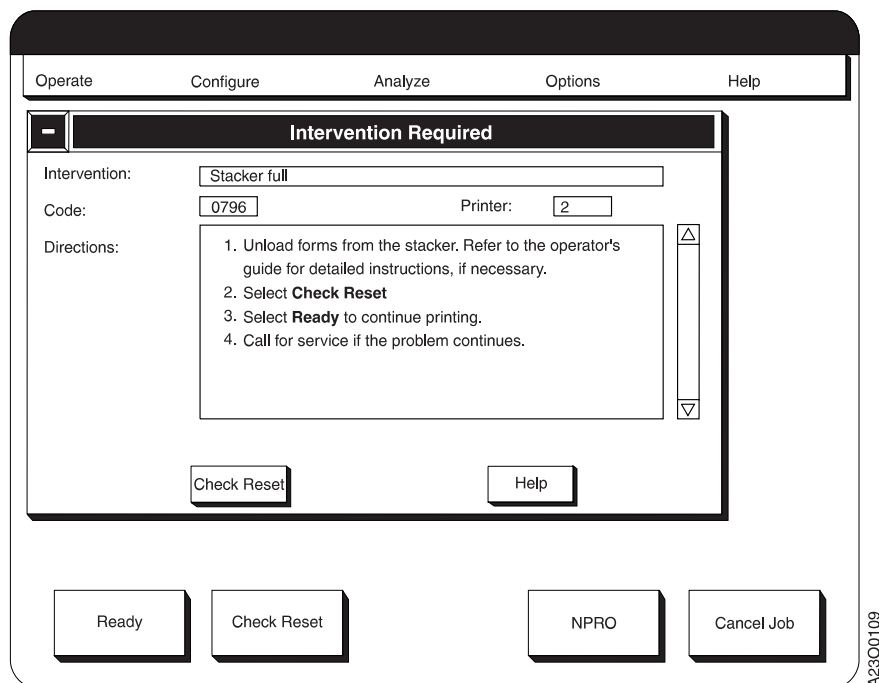

Figure 41. Intervention Required Window

This window contains the following:

- A short description of the detected condition.
- A four-character System Reference Code (SRC), which is used for logging intervention conditions.
- An indication of which printer the condition applies to.
- Function pushbuttons:

### Check Reset

Informs the control unit that you have completed all actions necessary to correct this interruption.

**Help** Displays help information.

### Notes

1. You must handle all Intervention Required conditions, except SRC D206, immediately. You can postpone SRC D206 (Ready Selected Before Forms Thread/Aligned), although you must eventually execute the **Thread/Align Forms** procedure before you can make the system Ready.
2. See Table 30 on page 281 for a list of all messages of this type.
3. Intervention Required messages appear on the printer Display Touch Screen.

## Status Messages

Status messages describe the condition of a printer or the system. Sometimes they are a response to operator action.

Status messages are only for your information and do not necessarily mean that something is wrong. However, if a printer is not performing the way you think it should, a status message can give you a clue about what to do.

Figure 42 shows a sample **Printer Status** window. The **Printer Status** window automatically appears when the system is powered-on. If you have closed the window, you can see it again by **SELECTING Printer Status** from the **Operate** pull-down menu.

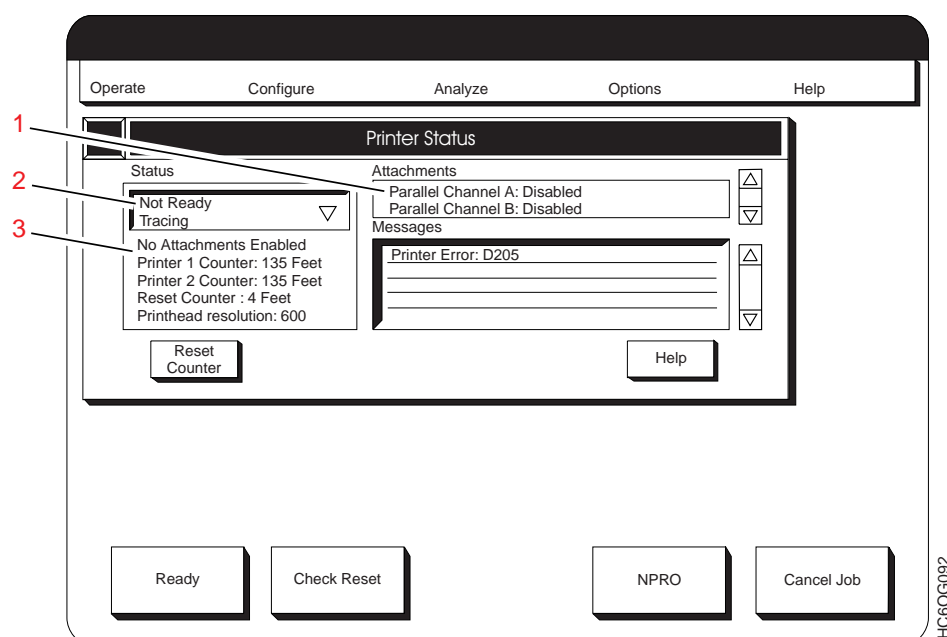

Figure 42. Printer Status Window

The window contains the following:

- **Printer Status 2**
  - In duplex mode, this field displays a 2-line overall system status. **SELECTING** this field displays more detailed information about both printers and their preprocessing/postprocessing device interfaces.
  - In simplex mode, this field displays a 2-line status for the individual printer. **SELECTING** this field displays more detailed information about the printer and its preprocessing/postprocessing device interfaces.

The status messages that may appear in each line in this field are shown in Table 29 on page 279.

- **Attachments Status 1**

This field contains a line of status for each installed host system interface.
- **System Status 3**

This field contains:

  - An overall system attachments status.

- Counters that show the total number of feet of forms run through the printers since they were originally manufactured.
  - A reset counter that shows the number of feet of forms processed through the system or printer since the last time the counter was reset. You can press the **Reset Counter** pushbutton to reset the counter.
- **Messages**  
This field displays any postponed **Printer Error** messages, and any active (no action taken at this time) **Out of Supplies** or **Intervention Required** messages.  
To act on a postponed message, select the message from the list.

**Note:** Printer status appears on the printer Display Touch Screen.

## Status Message Summary

Table 29. Printer Status Window - Status Field Messages

Message	Description
<b>LINE 1</b>	
READY	In duplex mode, the complete system is ready to accept print jobs from the host system.  In simplex mode, only the individual printer is ready.
NOT READY	In duplex mode, the complete system is not ready to accept print jobs from the host system.  In simplex mode, only the individual printer is not ready.
NOT READY AT PRINTER 1	In duplex mode, the system is not ready to accept print jobs from the host system because someone has pressed the <b>Stop</b> key on the Printer 1 Stacker Control Panel. The printer can be made ready only by pressing the <b>Ready</b> key on the Printer 1 Stacker Control Panel (not by <b>SELECTING</b> the <b>Ready</b> pushbutton on the Display Touch Screen ).  This message is not displayed in simplex mode.
NOT READY AT PRINTER 2	In duplex mode, the system is not ready to accept print jobs from the host system because someone has pressed the <b>Stop</b> key on the Printer 2 Stacker Control Panel. The printer can be made ready only by pressing the <b>Ready</b> key on the Printer 2 Stacker Control Panel (not by <b>SELECTING</b> the <b>Ready</b> pushbutton for Printer 2 on the Display Touch Screen).  This message is not displayed in simplex mode.
NOT READY AT PRINTER (Dual Simplex and Simplex)	This message is displayed for duplex systems in dual-simplex mode and for simplex printers. The message indicates that someone has pressed the <b>Stop</b> key on the printer Stacker Control Panel. The printer can be made ready only by pressing the <b>Ready</b> key on the printer Stacker Control Panel (not by <b>SELECTING</b> the <b>Ready</b> pushbutton on the Display Touch Screen).
NOT READY AT PRINTER (Simplex)	Someone has pressed the <b>Stop</b> key on the printer Stacker Control Panel. The printer can be made ready only by pressing the <b>Ready</b> key on the printer Stacker Control Panel (not by <b>SELECTING</b> the <b>Ready</b> pushbutton on the Display Touch Screen).
RECEIVING	In duplex mode, the system is receiving print job data from the host system.  In simplex mode, the individual printer is receiving host system data.
<b>LINE 2</b>	

Table 29. Printer Status Window - Status Field Messages (continued)

Message	Description
WARMING UP	In duplex mode, the fuser in one or both system printers is warming up so that print jobs can begin.  In simplex mode, the individual printer fuser is warming.
SLEEPING	In duplex mode, the Printer Configuration "Fuser Inactivity Timer" in one or both system printers has timed out and the fuser has been turned off.  In simplex mode, only the fuser in the individual printer has been turned off.
NOT AVAILABLE	In duplex mode, the Display Touch Screen cannot communicate with either or both of the system printers.  In simplex mode, the Display Touch Screen cannot communicate with the individual printer.  In either duplex or simplex modes, when an enabled preprocessing or postprocessing device has been powered off.
PRINTING	In duplex mode, the system is printing.  In simplex mode, only the individual printer is printing.
TRACING	In either duplex or simplex modes this indicates that a trace operation is running.
PRE/POSTPROCESSOR BUSY	In either duplex or simplex modes this indicates that an enabled preprocessing or postprocessing device is showing "Busy" status on its interface.
PRE/POSTPROCESSOR NOT READY	In either duplex or simplex modes this indicates that an enabled preprocessing or postprocessing device is showing "Not Ready" status on its interface.
PRE/POSTPROCESSOR EOF	In either duplex or simplex modes this indicates that an enabled preprocessing or postprocessing device is showing "End-of-File" status on its interface.
PRE/POSTPROCESSOR PAUSED	In either duplex or simplex modes this indicates that an enabled preprocessing or postprocessing device is showing "Paused" status on its interface.
"Blank"	No secondary status message to display.

## Messages with System Reference Codes

The following table lists all of the messages that include a system reference code. There are three types of messages included:

### Out of Supplies

The message appears on the **Out of Supplies** window (see "Out Of Supplies Messages" on page 276).

### Intervention Required

The message appears on the **Intervention Required** window (see "Intervention Required Messages" on page 277).

### Printer Error

The message appears on the **Printer Error** window (see "Printer Error Messages" on page 274).

**Note:** All of the messages are Printer Error messages unless noted otherwise. Also, note that all of the following messages appear on the **Printer Display Touch Screen**.



Table 30. SRC Messages

Code	Message Text	Type (Printer Error unless noted otherwise)
0104	Retractor position error	
0113	Tractor motor encoder error	
0114	Tractor motor overcurrent	
0115	Retractor seek error	
0116	Retractor motor overcurrent	
0117	Forms width sensor	
0118	Forms width sensor fuse	
0119	Forms jam at upper tractor	
011E	Tractor motor initial position error	
0121	Drum rotation error	
0122	Drum motor overcurrent	
0131	Tension arm down	
0132	Tension arm up	
0133	Skew error	
0134	Fuser wrap	
0135	Backup roll motor thermal	
0136	Backup roll closed error	
0137	Steering motor driver	
013A	Backup roll drive signal on	
013B	Backup roll not open	
0141	Felt oiler belt driver error	
0142	Oil pump driver error	
0143	Felt oiler belt motor always driven	
0144	Felt oiler belt motor never driven	
0145	Oil pump always driven	
0146	Oil pump never driven	
0152	Scuff roll motor thermal	
0156	Backup roll lift motor position error	
0157	Backup roll lift motor overcurrent	
0161	Stacker jam (light never sensed)	
0162	Pendulum motor overcurrent	
0163	Pendulum position error	
0164	Stacker jam (light always sensed)	
0166	Pendulum interface error	
0167	Pendulum motor overcurrent	
0169	Stacker cooling blower revolution error	
0171	Stacker table motor thermal	

Table 30. SRC Messages (continued)

Code	Message Text	Type (Printer Error unless noted otherwise)
0172	Stacker table timeout	
0174	Stacker safety switch on	
0175	Stacker table motor runs too long	
0176	Stacker forms length sensor	
017	Stacker length motor timeout	
017A	Right finger belt motor overcurrent	
017B	Left finger belt motor overcurrent	
0211	Charge corona voltage error	
0212	Transfer corona voltage error	
0213	Preclean corona voltage error	
0221	Mirror operating error	
0222	Video data active	
0223	Mirror motor drive off	
0224	Mirror motor start-up error	
0225	Resolution lens initial position error	
0226	Resolution lens motor overcurrent	
022A	PC drum cover is open (laser interlock)	
0231	Mag brush bias error	
0232	Conveyor roll rotation error	
0233	Mag roll motor thermal	
0234	Toner overfeed error	
0235	Toner underfeed error	
0236	Toner feed motor overcurrent	
0241	Primary erase lamp never on	
0243	Primary erase lamp always on	
0251	Cleaning brush rotation error	
0252	Cleaner brush motor thermal	
0253	Cleaner housing position error	
0254	Cleaning housing motor driver	
0264	Cyclone blower motor thermal	
0266	Cyclone blower rotation error	
0281	Preheat A/B overtemperature	
0282	Preheat A/B undertemperature	
0284	Preheat C/D undertemperature	
0286	Preheat element A lost temperature	
0287	Preheat element B lost temperature	
0288	Preheat element C lost temperature	

Table 30. SRC Messages (continued)

Code	Message Text	Type (Printer Error unless noted otherwise)
028A	Thermistor 1 over temperature	
028B	Thermistor 2 over temperature	
028C	Thermistor 3 over temperature	
028D	Thermistor 1 under temperature	
028E	Thermistor 2 under temperature	
028F	Thermistor 3 under temperature	
0291	Hot roll overtemperature	
0294	Hot roll overcurrent	
0295	Hot roll lamp never turns on	
0296	Hot roll lamp 1 relay always off	
0297	Hot roll lamp 1 filament open	
0298	Hot roll lamp 2 relay always off	
0299	Hot roll lamp 2 filament open	
029C	Hot roll lamp 3 filament open	
029D	Hot roll lamp 3 relay always off	
029E	Hot roll lamp 4 filament open	
029F	Hot roll lamp 4 relay always off	
0330–0339	Display Touch Screen error	
0511	Printer unexpectedly went into diagnostic mode or dropped power	
0521	Form length fuse	
0522	Laser driver fuse	
0523	PR sensor	
0524	Fuser sensors fuse	
0525	ST sensor fuse	
0611–0666	Printer interface error	
0783	Transfer station open	Intervention Required
0785	Change toner collector	Out of Supplies
0786	Add toner	Out of Supplies
0787	Check toner collector	Intervention Required
0788	Change developer mix	Out of Supplies
0789	Developer drain open	Intervention Required
078A	End of Forms	Intervention Required
078B	Developer running	Intervention Required
0791	Change fine filter	Out of Supplies
0792	Add fuser oil	Out of Supplies
0793	Change oiler belt	Out of Supplies
0794	Oiler gate open	Intervention Required

Table 30. SRC Messages (continued)

Code	Message Text	Type (Printer Error unless noted otherwise)
0795	Set forms direction	Intervention Required
0796	Stacker full	Intervention Required
0797	Stacker gate open	Intervention Required
0798	Stacker table down	Intervention Required
0799	Check fine filter	Intervention Required
0841	Postprocessor not ready	
0842	Postprocessor STOP line active	
A000	ESCON attachment: Program error	
A001	ESCON attachment: Functional error	
A010	ESCON Attachment: Card diagnostic failed. (Link A)	
A018	ESCON attachment: Wrap diagnostic failed. (Link A)	
A020	ESCON attachment: Card diagnostic failed. (Link B)	
A028	ESCON attachment: Wrap diagnostic failed. (Link B)	
A030	ESCON attachment: AIX system call failed.	
A040	ESCON attachment: Controller configuration value error	
A041	ESCON attachment: General load failure	
A042	ESCON attachment: No ESCON configuration file	
A050	ESCON attachment: Data overrun - link A	
A051	ESCON attachment: Data overrun - link B	
A052	ESCON attachment: Lost connection - link A	
A053	ESCON attachment: Lost connection - link B	
A054	ESCON attachment: Bus out check - link A	
A055	ESCON attachment: Bus out check - link B	
A056	ESCON attachment: Online failed - link A	
A057	ESCON attachment: Online failed - link B	
A058	ESCON attachment: Spurious interrupt - link A	
A059	ESCON attachment: Spurious Interrupt - link B	
A05A	ESCON attachment: Unknown CCW - link A	
A05B	ESCON attachment: Unknown CCW - link B	
A05C	ESCON attachment: Forced offline - link A	
A05D	ESCON attachment: Forced offline - link B	
A05E	ESCON attachment: Log only - link failure	
A05F	Link failure - link B	
A200	370 Parallel attachment: Data parity error	
A201	370 Parallel attachment: Data streaming overrun	
A203	370 Parallel attachment: Online failure	
A205	370 Parallel attachment: Bus out parity checks	

Table 30. SRC Messages (continued)

Code	Message Text	Type (Printer Error unless noted otherwise)
A206	370 Parallel attachment: Functional failure	
A209	370 Parallel attachment: Card diagnostic failed - Interface A	
A210	370 Parallel attachment: Card diagnostic failed - Interface B	
A211	370 Parallel attachment: Wrap diagnostic failed - Interface A	
A212	370 Parallel attachment: Wrap diagnostic failed - Interface B	
A213	370 Parallel attachment: Controller configuration failure	
A214	370 Parallel attachment: AIX system call failure	
A215	370 Parallel attachment: PCA card operation failure	
A216	370 Parallel attachment: PCA internal error	
A217	370 Parallel attachment: Bad file, cannot open	
A218	370 Parallel attachment: Program Error	
A220	370 Parallel attachment: Bad command	
A221	370 Parallel attachment: Line mode page mode switch	
A222	370 Parallel attachment: Data received after ACK request	
A400	Token Ring TCP/IP: Token Ring timeout	
A401	Token Ring TCP/IP: Basic test failed	
A402	Token Ring TCP/IP: Wrap test failed	
A403	Ethernet TCP/IP: Ethernet timeout	
A404	Ethernet TCP/IP: Basic test failed	
A405	Ethernet TCP/IP: Wrap test failed	
A406	Ethernet TCP/IP: 10Base2 failed	
A407	Ethernet TCP/IP: 10BaseT failed	
A40D	FDDI TCP/IP: FDDI timeout	
A40E	FDDI: Basic test failed	
A40F	FDDI: Wrap test failed	
A410	Ethernet TCP/IP: Diagnostic/hardware setting mismatch	
A440	TCP/IP: PSF protocol error	
A441	TCP/IP: ASA protocol error	
A442	TCP/IP: Internal error	
A450	Ethernet TCP/IP: Local software error	
A451	Ethernet TCP/IP: Remote software error	
A452	Ethernet TCP/IP: Network software error	
A453	Ethernet TCP/IP: Unknown software error	
A454	Ethernet TCP/IP: Local hardware error	
A455	Ethernet TCP/IP: Remote hardware error	
A456	Ethernet TCP/IP: Network Hardware error	
A457	Ethernet TCP/IP: Unknown hardware error	
A458	Ethernet TCP/IP: Unknown local error	

Table 30. SRC Messages (continued)

Code	Message Text	Type (Printer Error unless noted otherwise)
A459	Ethernet TCP/IP: Unknown remote error	
A45A	Ethernet TCP/IP: Unknown network error	
A45B	Ethernet TCP/IP: Unknown error	
A45C	Ethernet TCP/IP: Invalid configuration during enable	
A45D	Ethernet TCP/IP: Invalid configuration during run	
A460	Token Ring TCP/IP: Local software error	
A461	Token Ring TCP/IP: Remote software error	
A462	Token Ring TCP/IP: Network software error	
A463	Token Ring TCP/IP: Unknown software error	
A464	Token Ring TCP/IP: Local hardware error	
A465	Token Ring TCP/IP: Remote hardware error	
A466	Token Ring TCP/IP: Network hardware error	
A467	Token Ring TCP/IP: Unknown hardware error	
A468	Token Ring TCP/IP: Unknown local error	
A469	Token Ring TCP/IP: Unknown remote error	
A46A	Token Ring TCP/IP: Unknown network error	
A46B	Token Ring TCP/IP: Unknown error	
A46C	Token Ring TCP/IP: Invalid configuration during enable	
A46D	Token Ring TCP/IP: Invalid configuration during run	
A470	FDDI TCP/IP: Local software error	
A471	FDDI TCP/IP: Remote software error	
A472	FDDI TCP/IP: Network software error	
A473	FDDI TCP/IP: Unknown software error	
A474	FDDI TCP/IP: Local hardware error	
A475	FDDI TCP/IP: Remote hardware error	
A476	FDDI TCP/IP: Network hardware error	
A477	FDDI TCP/IP: Unknown hardware error	
A478	FDDI TCP/IP: Unknown local error	
A479	FDDI TCP/IP: Unknown remote error	
A47A	FDDI TCP/IP: Unknown network error	
A47B	FDDI TCP/IP: Unknown error	
A47C	FDDI TCP/IP: Invalid configuration during enable	
A47D	FDDI TCP/IP: Invalid configuration during run	
A501	Internal printing: Invalid event	
A502	Internal printing: File error	
A503	Internal printing: Unexpected ACK	
A504	Internal printing: Host recovery bit set	
A505	Internal printing: Invalid request from ASA	
AF00	Attachment subsystem cannot open attach driver.	

Table 30. SRC Messages (continued)

Code	Message Text	Type (Printer Error unless noted otherwise)
AF01	Attachment subsystem cannot create a file.	
AF02	Attachment subsystem cannot open a file.	
AF11	Attachment card present before last shutdown not found	
B000	The printer has been powered on or restarted.	
B001	An attachment has been enabled.	
B002	An attachment has been reset.	
B003	Printer attributes have changed.	
B004	MICR has been enabled.	
B005	MICR has been disabled.	
B006	Postprocessor enabled or disabled	
B007	Medium modifier changed	
B008	Stacker enabled or disabled	
B009	Print adjust has been entered.	
B00A	Job has been canceled.	
B00C	Printer has been made NOT READY.	
B00D	Operator has overridden jam recovery.	
B00E	Jam recovery has been suppressed.	
B010	Attachment has been suspended.	
B011	Attachment has been released from suspension.	
B012	Paper path rethreaded	
BA00	Program check - Type 1	
BA01	Program check - Type 2	
BA02	Program check - Type 3	
BC01	Invalid form size	
BC02	Invalid print head resolution	
BC03	Invalid form source	
BC04	Invalid maximum form size	
BC05	Memory configuration has changed	
BF01	File read error, hard disk	
BF02	File write error, hard disk	
BF03	Hard disk backup to diskette failure	
C000	Operator touch screen error	
C002	Microcode update diskette error	
C003	Microcode update failed.	
C004	Microcode update failed.	
C005	X Window event	
D080	MIC abort	

Table 30. SRC Messages (continued)

Code	Message Text	Type (Printer Error unless noted otherwise)
D081	MIC permanent error	
D082	MIC failure during diagnostics	
D083	MIC failure during initial power on EPROM diagnostics	
D084	MIC microcode error	
D090	MIC failure during attention light test	
D091	MIC failure during printer activate test	
D092	MIC failure during printer interface test	
D093	MIC failure during alarm test	
D095	MIC failure during intelligent interface wrap test	
D096	MIC failure during coupled interface wrap test	
D097	MIC failure during pre/postprocessor run motor test	
D098	MIC failure during pre/postprocessor offset test	
D099	MIC failure during printer dormant test	
D201	Fuser warming timeout	
D202	Pre/postprocessor PAUSE was active more than 100 seconds.	
D203	Pre/postprocessor STOP line became active.	
D204	Pre/postprocessor NOT READY line became active.	
D205	PAGE COMPLETE timeout	
D206	Ready was selected before threading forms	Intervention Required
D208	Communication with the MIC has failed	
D20A	Pre/postprocessor BUSY was active too long.	
D20B	Incorrect printer speed	
D20C	Form length mismatch	
D20D	Form width mismatch	
D20E	Pre/postprocessor processor power is off.	
D20F	Undefined character received by intelligent interface	
D210	Illegal position received by intelligent interface	
D211	Illegal media modification received by intelligent interface	
D212	MICR data received while MICR option disabled	
D213	Availability of intelligent postprocessor has changed	
D214	Intelligent postprocessor forms jam	
D215	MIC to intelligent interface communications failure	
D216	Intelligent interface response timeout	
D217	Command rejected by intelligent interface	
D218	Intelligent interface responded, but is not in configuration	
D219	Intelligent interface type not recognized	
D21A	Intelligent postprocessor restarted	



Table 30. SRC Messages (continued)

Code	Message Text	Type (Printer Error unless noted otherwise)
D21B	Intelligent postprocessor failed to clear buffer	
D21C	PAGE COMPLETE not sent by intelligent interface	
D21E	Side 2 Verify has stopped checking pages	
D702	Out of data while printing	
D703	Printer unable to do requested command	
D705	Printhead overrun while printing	
D706	BEAM DETECT was not received.	
D707	Loss of printer DVS (vertical sync) pulse	
D70B	Printhead underrun	
D70C	Print buffers out of sequence	
D70D	DVS (vertical sync) pulse frequency error	
D70E	Mechanism Interface Card (MIC) parity error	
D70F	MIC Print Quality Enhancement (PQE) error	
D714	MIC timer 2 error	
D715	Parity error between MIC and PQE card	
D716	PQE card failed to initialize.	
D717	Early ACK from intelligent postprocessor	
D718	MIC failed to send frame to intelligent interface	
D719	Response timeout on intelligent interface	
D71A	Noise on pre/postprocessor port 1	
D71B	Noise on pre/postprocessor port 2	
D71C	Noise on pre/postprocessor port 3	
D71D	6 PPI sync pulse missing	
D71E	Scan line error while printing	
D71F	Side1/Side 2 mismatch	
D720	Verification mark position incorrect	
D721	Hardware error: verification mark sensor	
D723	MIC memory failure	
D724	Side 2 verify has been disabled	



## Appendix A. Valid Form Lengths in Inches

Table 31. Examples of Some Valid Form Lengths in Inches

If the Form Length is:	Use this value at the Display Touch Screen:	Use this value at the Stacker Control Panel:
3.0	3.0	See note 2
3½	3.5	See note 2
4.0	4.0	See note 2
4½	4.5	See note 2
5.0	5.0	See note 2
5½	5.5	See note 2
6.0	6.0	See note 2
6½	6.5	See note 2
7.0	7.0	7.0
7½	7.5	7½
8.0	8.0	8.0
8 <sup>1</sup> / <sub>6</sub>	8.1	See note 1
8 <sup>1</sup> / <sub>3</sub>	8.3	8 <sup>1</sup> / <sub>3</sub>
8½	8.5	8½
8 <sup>2</sup> / <sub>3</sub>	8.6	8 <sup>2</sup> / <sub>3</sub>
See note 1	8.8	See note 1
9.0	9.0	9.0
9½	9.5	9½
10.0	10.0	10.0
10½	10.5	10½
11.0	11.0	11.0
11½	11.5	11½
12.0	12.0	12.0
12½	12.5	12½
13.0	13.0	13.0
13½	13.5	13½
14.0	14.0	14.0

**Notes:**

1. You can define form lengths in one-sixth of an inch increments at the Display Touch Screen. For reference, see 8<sup>1</sup>/<sub>3</sub> and 8<sup>2</sup>/<sub>3</sub> above.  
The stacker control panel does not allow form lengths in one-sixth of an inch. The smallest increment allowed on the stacker control panel is one-third of an inch.
2. Setting equals forms length *as measured from fold perforation to fold perforation*.
3. Form lengths as prefolded greater than 14.0 inches are permissible if the stacker is disabled and a postprocessing device is installed and enabled.



# Appendix B. Physical System Layouts

## Simplex Models

The dimensions of the InfoPrint 3000 simplex printers, the service clearance around the allowable configurations of these units, and the power cable and channel cable locations are shown in Figure 43.

**Note:** The minimum size of the Channel Cable Access opening is 200 x 200 mm (8 x 8 in.).

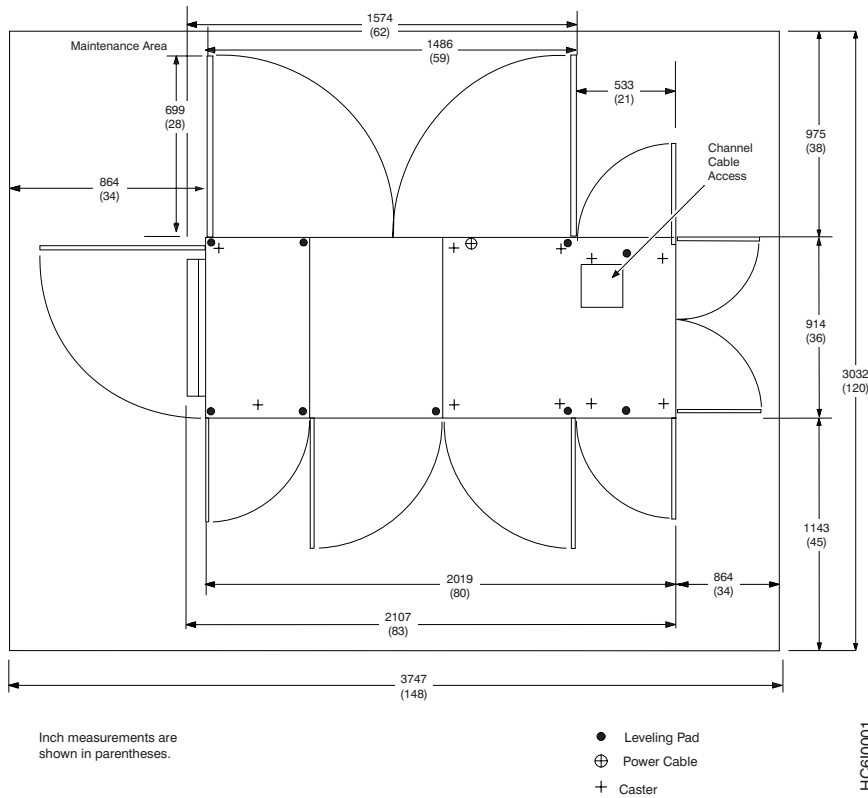

Figure 43. Simplex Configuration

## Duplex Models

The dimensions of the InfoPrint 3000 duplex printers, and the Buffer/Flipper Unit **1**, the optimum separation of the units, the service clearance around the allowable configurations of these units, and the power cable and channel cable locations are shown in Figure 44 and Figure 45 on page 295.

**Note:** The minimum size for Channel Cable Access opening is 200 x 200 mm (8 x 8 in.).

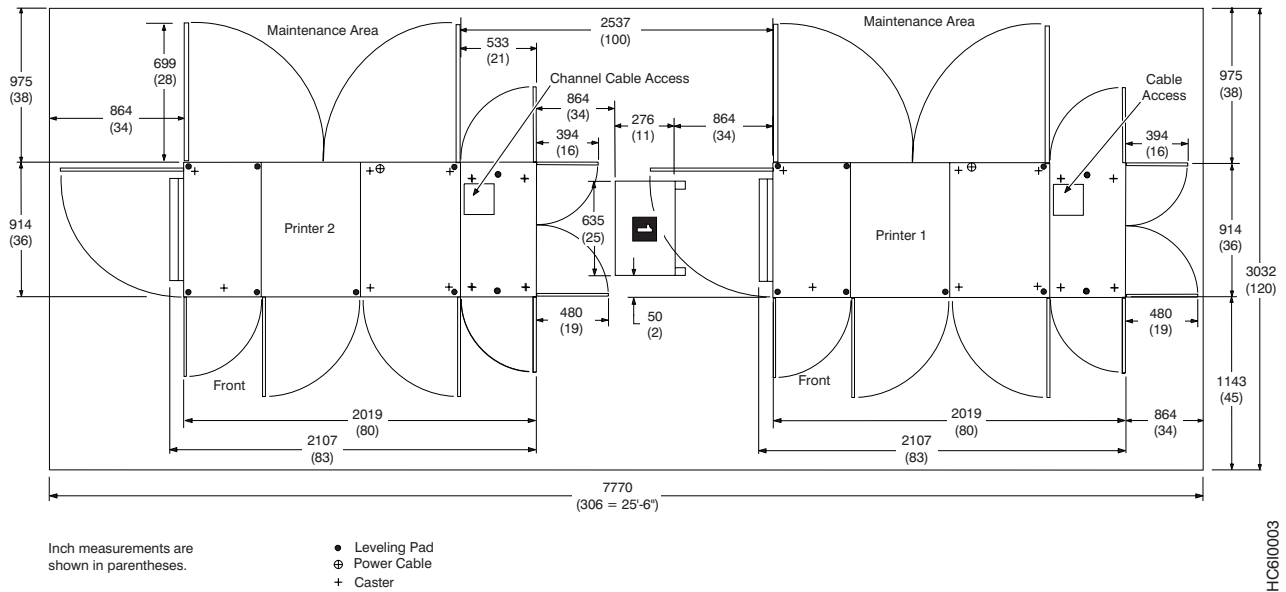

Figure 44. Duplex Inline Configuration

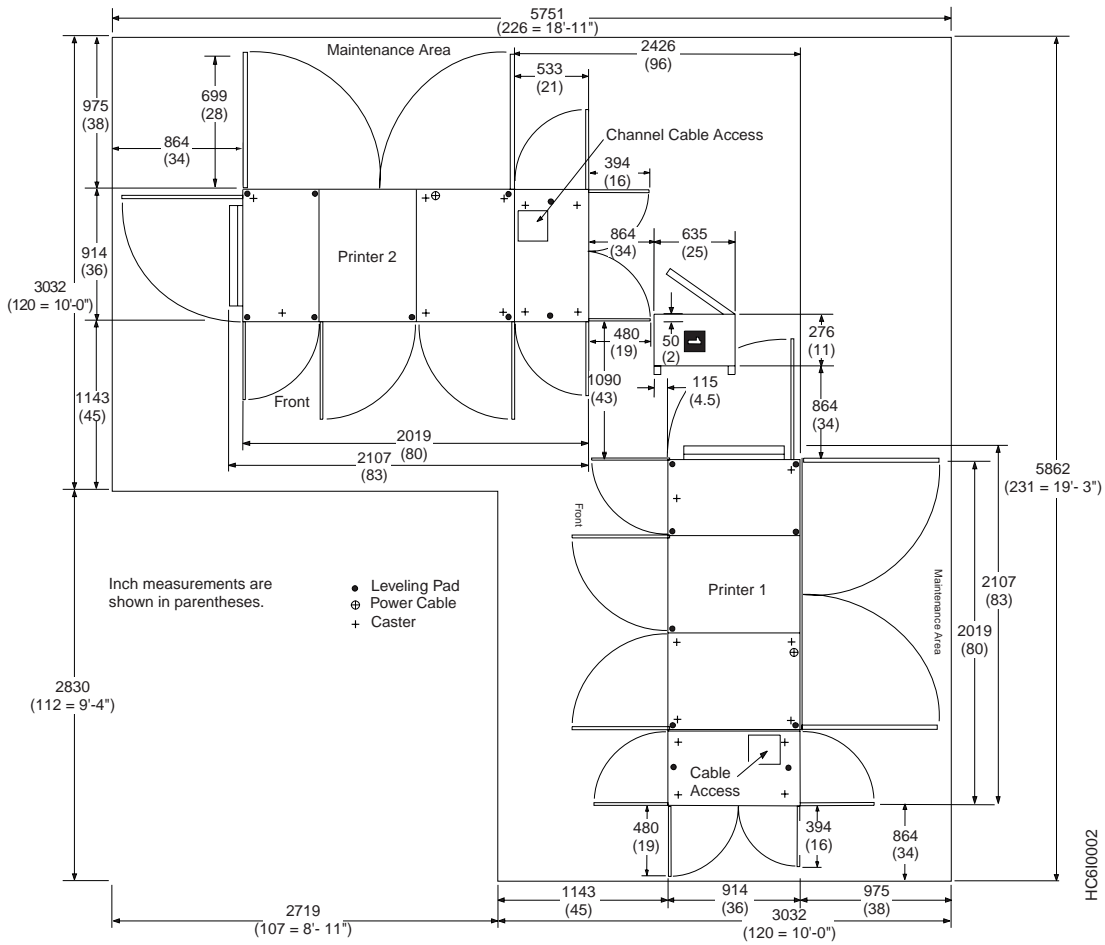

Figure 45. Duplex Left Angle Configuration





---

## Glossary

The following terms are defined as they are used in InfoPrint 3000 documentation. If you do not find the term you need, refer to the index or to the *IBM Dictionary of Computing*, SC20-1699.

The following cross-references are used in this glossary:

- **Contrast with.** This refers to a term that has an opposed or substantively different meaning.
- **Synonym for.** This indicates that the term has the same meaning as another term, which is defined.
- **Synonymous with.** This identifies terms that are synonyms for the term that is defined.
- **See.** This refers to multiple-word terms that have the same last word.
- **See also.** This refers to related terms that have a similar, but not synonymous, meaning.

### A

**ABIC.** Adaptive Bilevel Image Compression.

**adhesive label.** Special-application material; typically consists of paper labels coated on one side with an adhesive mixture temporarily affixed to backing material. See also *carrier*.

**Advanced Function Common Control Unit (AFCCU).** An IBM RISC-based control unit with code common to all printers that use the AFCCU.

**Advanced Function Image and Graphics RPQ.** An optional feature for adding the capability for the InfoPrint 3000 to directly process IO1 image and DR2 vector graphics data streams.

**AEA.** Alternate exception action.

**AFCCU.**

**AFIG.** Advanced Function Image and Graphics.

**AFP.** (1) Advanced Function Printing. (2) Advanced Function Presentation.

**AFPE.** Advanced Function Print Finishing.

**all-points addressability (APA).** The capability to address, reference, and position text, overlays, and images at any defined point on the printable area of a page.

**ANSI.** American National Standards Institute.

**APA.** All-points addressable.

**application.** The use to which an information processing system is put; for example, a payroll application, an airline reservation application, a network application.

**application program.** A program written for or by a user that applies to the user's work, such as a program that does inventory control or payroll.

**application programmer.** A person who develops application programs. Contrast with *system programmer*.

**ARQ.** Active record queue.

**ASCII.** American National Standard Code for Information Interchange.

**ASHRAE.** American Society of Heating, Refrigeration, and Air Conditioning Engineers.

### B

**bar code.** A code representing characters by sets of parallel bars of varying thickness and separation that are read optically by transverse scanning.

**basis weight.** The weight in pounds of a ream (500 sheets) of paper cut to a given standard size for that grade; for example, 25 x 38 inches for book papers, 17 x 22 inches for bond papers, and other sizes for other grades. The basis weight of continuous forms for computer output is based on the size for bond papers.

**BCOCA.** Bar Code Object Content Architecture.

**binder holes.** A series of holes or slots punched at set intervals that allows the form to be inserted in a loose-leaf or ring binder.

**bond (paper).** Paper formulated with at least 80% wood pulp. Bond-paper forms work best in the InfoPrint 3000.

**BTS.** Burster/Trimmer/Stacker.

### C

**calender.** A process to make paper smooth or glossy by passing it through a series of metal rollers during the last steps of a paper-making machine.

**calender cut.** Slits, glazed lines, or discolored lines across the paper caused when wrinkles pass through the calender rollers.

**caliper.** The thickness of forms. This is usually expressed in thousandths of an inch.

**carrier.** The backing material for labels. Labels consist of the printable material, the adhesive, and the carrier.

**carrier holes.** The holes in the side margins on continuous-forms paper. When placed on the tractor pins, the holes maintain paper alignment and registration, and control the movement of the paper. Synonymous with *tractor holes*.

**CCITT.** Comité Consultatif International Telegraphique et Telephonique.

**CCW.** Channel command word.

**CE.** Customer Engineer (IBM).

**CGPC.** Canadian Grocery Product Code.

**chad.** (1) The material separated from a data medium when punching a hole. (2) The residue separated from the carrier holes in continuous forms.

**change.** As used in InfoPrint 3000 action messages, instructs the printer operator to remove and discard a used component and then install a new one. For example, the CHANGE TONER COLLECTOR message indicates that the operator should take out the toner-collector bottle, throw it away, and put in a new one.

**channel command.** An instruction directing a data channel, control unit, or device to perform an operation or set of operations.

**character.** A letter, number, punctuation mark, or special graphic used for the production of text.

**character set.** (1) A finite set of different characters that is complete for a given purpose; for example, the character set in ISO Standard 646, "7-bit Coded Character Set of Information Processing Interchange." (2) A group of characters used for a specific reason; for example, the set of characters a printer can print.

**check.** As used in InfoPrint 3000 action messages, instructs the printer operator to inspect a component. For example, the CHECK TONER COLLECTOR message indicates that the operator should look at the toner-collector bottle and ensure that it is physically present, in the proper place, and correctly installed.

**clear.** As used in InfoPrint 3000 action messages, instructs the printer operator to remove crumpled forms, paper scraps, and other debris from the printer. For example, the CLEAR UPPER TRACTOR message indicates that forms are wedged in the transfer station area, and the operator must remove them before the printer can operate.

**coated paper.** Paper that has had a surface coating applied to produce smoothness.

**configuration.** (1) The arrangement of a computer system or network as defined by the nature, the number, and the chief characteristics of its functional units. More specifically, the term configuration may refer to a hardware configuration or a software configuration. (2) The devices and programs that make up a system, subsystem, or network.

**configure.** The procedure used to customize the InfoPrint 3000 to a specific operating and communication environment.

**connector.** A means of establishing electrical flow.

**constant data.** Data that does not change; for example, the company letterhead and standard text in form letters, or the headings and boxes on a preprinted form.

**continuous forms.** A series of connected forms that feed continuously through a printing device. The connection between the forms is perforated to allow the user to tear them apart.

**controlled-access area.** An area where access is limited to authorized personnel.

**controlling computer.** The processing unit to which the InfoPrint 3000 are attached through a channel interface.

**controlling computer system.** The data-processing system to which a network is connected and with which the system can communicate.

**corner cut.** In a form, a cut or opening of any size containing one or more right angles.

**corona.** A small diameter wire (or wires, depending on the function) to which a high voltage is applied, causing ionization of the air. The ionization creates an electrical charge to perform various functions during the printing process.

**CSW.** Channel status word.

**cure.** The process of drying ink sufficiently for minimum transfer of the ink to any parts of the printer it contacts.

**cut.** The severed part of a perforation. Cuts are separated by ties.

**cutout.** A part of the form that has been eliminated or perforated for subsequent removal; for example, corner cuts and binder holes.

## D

**DASD.** Direct access storage device.

**data streaming.** A noninterlocked method of data transfer used by the printer channel to decrease data transfer time during write operations.

**DBCS.** Double-byte character set.

**DCF.** Document Composition Facility.

**developed image.** The image that has been exposed onto the photoconductor and covered with toner by the developer.

**developer mix.** A combination of carrier beads and toner in which the beads electrically charge the toner.

**diagnostic.** Pertaining to the detection and isolation of errors in programs and faults in equipment.

**diagnostic mode.** The operational mode in which the printer can check itself in case of a malfunction. When the InfoPrint 3000 is in diagnostic mode, it is not accepting information from the attached controlling computer system. In the InfoPrint 3000, only service representatives can use diagnostic mode. Contrast with *print mode* and *test mode*.

**direct attach.** The environment in which an application program directly allocates the InfoPrint 3000 printing subsystem.

**dishing.** The curve a stack of forms takes when folded or refolded at the fold perforation.

**diskette.** A thin, flexible, magnetic disk enclosed in a protective jacket.

**Document Composition Facility (DCF).** An IBM licensed program that provides text formatting for the InfoPrint 3000.

**double-byte character set (DBCS).** A set of characters in which each character is represented by a 2-byte code. Languages such as Japanese, Chinese, and Korean, which contain more symbols that can be represented by 256 code points, require double-byte character sets. Because each character requires 2 bytes, the typing, display and printing of DBCS characters requires hardware and programs that support DBCS.

**down fold.** Fanfold forms are alternately folded. When fanfold forms are unfolded and held horizontally, a fold is a down fold if it points down from the horizontal surface.

**DPE.** Decompression Performance Enhancement.

**drag.** The resistance to forms feeding freely into the printer; for example, the form rubbing against the carton.

**duplex printing.** A mode of printing on both sides of a form. Contrast with *simplex printing*.

## E

**EBCDIC.** Extended Binary-Coded Decimal Interchange Code.

**EC.** Engineering change.

**electronic overlay.** A collection of constant data electronically composed in the controlling computer. Can be merged with variable data on a page during printing. An electronic overlay defines its own environment. It can be in coded form or raster pattern form. See also *preprinted form*.

**electrophotographic process.** The creation of an image on forms by uniformly charging the photoconductor, creating an electrostatic image on the photoconductor, attracting negatively charged toner to the discharged areas of the photoconductor, and transferring and fusing the toner to forms.

**emboss.** To press and raise the surface of paper into a design. Embossed paper appears thicker than nonembossed paper, can increase printer wear, and can degrade print quality.

**end-of-forms sensor.** A sensor that detects when the last sheet of a form enters the printer.

**error log.** (1) A data set or file in a product or system where error information is stored for later access. (2) A record of machine checks, device errors, and volume statistical data.

**ESCON.** Enterprise System Connection.

**ESCON channel.** A channel having an Enterprise Systems Connection channel-to-control-unit I/O interface that uses optical cable as a transmission medium.

**ESMM.** End Select Medium Modification.

**Ethernet.** A local area network that allows attachments to transmit on the network without prior coordination.

## F

**fanfold.** Continuous forms that are alternately folded at regular intervals, usually on a perforation.

**Fiber Distributed Data Interface (FDDI).** An ANSI standard for a 100 Mbps LAN using optical fiber cables.

**FLSE.** Font Library Service Facility.

**fold memory.** The ability of a form to refold at the fold perforation after exposure to heat during the fusing process.

**fold perforation.** The perforation on which a form is folded during manufacture and refolded after printing. See also *page perforation*.

**Font Library Service Facility (FLSF).** A licensed program that provides a way to make changes to a font

while retaining its correct format, as defined by the architecture and as required by Print Services Facility.

**format.** (1) The arrangement or layout of data on a data medium. (2) The size, style, type of page, margins, printing requirements, and so on, of a printed page.

**FORMDEF.** Form definition.

**forms.** The material on which output data is printed, such as paper or adhesive labels. The area between perforations on continuous printer forms. See *electronic overlay* and *preprinted form*.

**forms path.** The entire route that forms travel during processing. The forms path usually begins where the forms are loaded and ends at the stacker. Synonym for *paper path*.

**form definition (FORMDEF).** A statement that specifies the attributes of a physical page, such as the number of copies and one-sided or two-sided printing.

**fuse.** To use heat and pressure to blend toner onto forms to make a permanent bond.

## G

**GCGID.** Graphic Character Global Identifier.

**GCSGID.** Graphic Character Set Global Identifier.

**GDDM.** Graphical Data Display Manager.

**GOCA.** Graphics Object Content Architecture.

**graphic.** A symbol produced by a process such as handwriting, drawing, or printing. See also *vector graphics*.

**grayed out.** Indicates that a Display Touch Screen selection is not active and cannot be selected. For example, the Check Reset pushbutton is grayed out when the printer is in Ready status.

**Graphical Data Display Manager (GDDM).** An IBM licensed program that allows pictures to be defined and displayed through function routines.

## I

**IBM branch office.** The local IBM sales office.

**IBM Customer Engineer (CE).** An IBM service representative who performs maintenance services for IBM hardware.

**IBM Installation Planning Representative.** An IBM representative who assists customers in planning and meeting the requirements for installing hardware.

**IBM Marketing Representative.** An IBM representative who takes product orders.

**IBM MMR.** Similar to MMR 2-dimensional image compression algorithm.

**IBM Service Representative.** An IBM representative who services IBM products in the field.

**IBM World Trade Corporation.** A subsidiary of IBM that manufactures and markets IBM products outside of the United States of America.

**IHF.** Image Handling Facility.

**IML.** Initial microcode load.

**impact printer.** A printer in which printing is the result of mechanical impacts. Contrast with *nonimpact printer*.

**installation.** (1) In system development, preparing and placing a functional unit in position for use. (2) A particular computing system, including the work it does and the people who manage it, operate it, apply it to problems, service it, and use the results it produces.

**installation verification procedure.** A procedure distributed with IBM licensed programs that tests the newly installed IBM programs to verify that the basic facilities of the programs are functioning correctly.

**Intelligent Printer Data Stream (IPDS).** Information the system sends to printers that contains decision-making capability. Generally, this information contains basic formatting, error recovery, and character data.

**I/O.** Input/Output.

**IOCA.** Image Object Content Architecture.

**IPDS.** Intelligent Printer Data Stream.

**IPL.** Initial program load.

**IPM.** Impressions per minute.

**ISO sizes.** Pertaining to a set of paper sizes selected from those standardized by the International Organization for Standardization (ISO) for use in data processing.

## J

**jam.** In a printer, a condition where forms have become blocked or wedged in the forms path so the printer cannot operate.

**JES2.** An MVS subsystem that receives jobs into the system, converts them to internal format, selects them for running, processes their output, and purges them from the system. In an installation with more than one processor, each JES2 processor independently controls its job input, scheduling, and output processing.

**JES3.** An MVS subsystem that receives jobs into the system, converts them to internal format, selects them for running, processes their output, and purges them from the system. In complexes that have several loosely coupled processing units, the JES3 program manages processors so that the global processor exercises centralized control over the local processors and distributes jobs to them via a common job queue.

## K

**KB.** Kilobyte (1KB=1 024 bytes).

## L

**LAN.** Local area network.

**landscape orientation.** Text and images that are printed parallel to the longer side of the forms.

**laser (light amplification by stimulated emission of radiation).** A device that emits a beam of coherent light.

**latent image.** In a printer, the invisible image that exists in the sensitized material after exposure but before development.

**layout plan.** A list of requirements, such as electrical and space, that must be considered before installing the IBM InfoPrint 3000.

**library.** A collection of related files. For example, one line of an invoice may form an item, a complete invoice may form a file, and the collection of inventory control files may form a library. The libraries used by an organization are known as the data bank.

**licensed program.** A separately priced program that bears an IBM copyright and is offered to customers under the terms and conditions of the Agreement for IBM Licensed Programs.

**line printer.** A printer that prints a line of characters as a unit. Contrast with *page printer*.

**logical page.** The print on the page, such as composed text, graphics, and fonts within defined margins.

**logo.** An identifying emblem, statement, or motto of a company.

## M

**MB.** Megabyte (1MB=1 048 576 bytes).

**MICR.** Magnetic ink character recognition.

**microcode.** In the InfoPrint 3000, refers to the microprogramming stored on the microcode (or EC)

diskette. Microcode is used by the control unit to manage the printer and its functions.

**microperforation.** Extremely small perforations. After forms are separated, those with microperforations typically have smoother edges than those with regular perforations.

**MIH.** Missing interruption handler.

**MMR.** Modified-Modified READ; 2-dimensional image compression algorithm. Also referred to as CCITT Group 4.

**MR.** Modified READ; (READ=Relative Element Address Designate) 2-dimensional image compression algorithm. Also referred to as CCITT Group 3.

**Multiple Virtual Storage/System Product (MVS/SP).** Consisting of MVS/System Product Version 1 and the MVS/370 Data Facility Product operating on a System/370 processor.

## N

**nonimpact printer.** A printer in which printing is not the result of mechanical impacts. Contrast with *impact printer*.

**nonprocess runout (NPRO).** An operation that moves forms through the forms path without printing.

## O

**OCR.** Optical character recognition.

**offset paper.** A grade of paper to which sizing is added to resist moisture and surface during printing by ink presses.

**OGL.** Overlay Generation Language.

**operating environment.** The physical environment; for example, temperature, humidity, layout, or power requirements.

**operating requirements.** A list of requirements, such as environmental, electrical, and space, that must be satisfied before the IBM InfoPrint 3000 can be installed.

**Operating System/Virtual Storage (OS/VS).** A compatible extension of the IBM System/360 Operating System that supports hardware and the extended control facilities of System/370

**optical character recognition (OCR).** Character recognition that uses optical means to identify graphic characters.

**orientation.** The number of degrees an object is rotated relative to a reference; for example, the

orientation of an overlay relative to the page point of origin. See also *text orientation*.

**OS/VS.**

**overlay.** See *electronic overlay*.

**Overlay Generation Language/370 (OGL/370).** The licensed program that is used to create electronic overlays.

## P

**page.** A printed form. See also *logical page* and *physical page*.

**page definition (PAGEDEF).** A statement that specifies attributes of a logical page, such as the width of its margins and the orientation of text.

**page perforation.** The perforation that defines the page of a form. It may or may not be at a fold in the form. A form may have several pages between each fold. See also *fold perforation*.

**page printer.** A device that prints one page as a unit. Contrast with *line printer*.

**Page Printer Formatting Aid (PPFA).** A licensed program that creates form definitions (FORMDEFs) and page definitions (PAGEDEFs).

**pallet.** A portable platform for handling, storing, or moving materials.

**paper break.** A separation, either at a perforation or from a tear, of the continuous-forms paper.

**paper path.** The entire route that forms travel while they are being processed. The paper path usually begins where the forms are loaded and ends at the stacker. Because not all forms are paper, the term *forms path* is preferred.

**parallel channel.** A channel having a System/360 or System/370 channel-to-control unit interface that uses bus-and-tag cables as a transmission medium. Contrast with *ESCON channel*.

**parameter.** A variable that is given a constant value for a specified application and that may denote the application.

**PC.** Photoconductor.

**PC drum.** A hollow cylinder that is covered with photoconductive material.

**pel (picture element).** (1) An element of a raster pattern; a point where a toned area on the photoconductor may appear. (2) On an all-points-addressable output medium, each pel is an

addressable unit. On a row-column addressable output medium, the only pel addressable is the beginning of a character cell.

**PEM.** Print-error marker.

**perforation.** A linear series of unconnected cuts in the continuous-forms paper. The interval between cuts is referred to as a tie. The perforation defines either a fold or page boundary. See also *cut, fold perforation, microperforation, and page perforation*.

**photoconductor.** The material that is wrapped about the drum. The medium for transferring images to paper.

**physical page.** The form on which the printer is printing, such as an 8½ x 11-inch sheet of paper.

**physical planner.** The person in an organization who plans the environmental, electrical, and space requirements for your facility.

**planning coordinator.** The person in your organization who is responsible for coordinating all the planning and installation activities for the InfoPrint 3000.

**plant.** A manufacturing location.

**PMF.** Print Management Facility.

**point of origin.** The location of the first print position on a logical page. The point of origin is usually stated in terms of X and Y coordinates. The point of origin used by a printer can be affected by factors such as printable area and forms orientation.

**portrait orientation.** Pertaining to a display or hard copy with greater height than width.

**PPFA.** Page Printer Formatting Aid.

**preprinted form.** A sheet of forms containing a preprinted design of constant data with which variable data can be combined. See also *electronic overlay*.

**Print Management Facility (PMF).** An interactive menu-driven program that can be used to create and modify fonts and to define output formatting for data printed on the IBM InfoPrint 3000.

**print mode.** The operational mode in which information is received from the attached controlling computer system and printed output is produced. Contrast with *test mode* and *diagnostic mode*.

**print position.** The physical positions of the characters constituting a print line relative to the form.

**print quality.** The quality of printed output relative to existing standards and in comparison with jobs printed earlier.

**Print Quality Enhancement (PQE).** A printer facility that provides edge smoothing along diagonal lines, fine fidelity protection, and independent boldness control.

**Print Services Access Facility (PSAF).** A menu-driven, print-parameter selection program for page printers controlled by PSF.

**print surface.** The side of a form that receives the printed image.

**printer utility module (PUM).** A section of Printer 1 in a duplex configuration. It includes:

- Operator alert assembly
- Power control panel
- System interconnection electronics
- Preprocessing/postprocessing device interfaces

**PSF.** Print Services Facility.

## R

**RAM.** Random access memory.

**raster.** (1) In computer graphics, a predetermined pattern of lines that provides uniform coverage of a display space. (2) The coordinate grid that divides the display area of a display device. (3) In the InfoPrint 3000 Printer Subsystem, an on/off pattern of electrostatic images produced by the laser print head under control of the character generator.

**raster pattern.** A series of picture elements (pels) arranged in scan lines to form an image.

**registration.** In printing, refers to the relative print positions of images that are printed at different times. For example, when you process preprinted forms, the registration is good if the new image printed by the InfoPrint 3000 aligns correctly with the preprinted image. Print that extends beyond box edges and text that overlaps other text are examples of poor registration.

**resource.** (1) People, equipment, or material used to perform a task or a project. (2) Any facility of a computing system or operating system required by a job or task, including main storage, input/output (I/O) devices, processing units, data sets, and controller processing programs; for example, page printers use resources such as form definitions, page definitions, and fonts.

**reverse heading.** A heading where each character is highlighted by reversing the color of the character with its background; for example, changing a black character on a white background to a white character on a black background.

**RPQ.** Request for price quotation.

## S

**SBCS.** Single-byte character set.

**scanner.** A device that examines OCR, graphics, MICR, or bar-code patterns and generates electrical signals corresponding to the pattern. It sends the signals to a computing device for processing.

**screen or screening.** In document printing, a sheet of material, usually film, carrying a regular pattern of small dots. When printing, ink adheres only to the dots, and many dots close together appear solid. This method prints large areas of ink on paper but uses much less ink than printing the same area with solid ink.

**SCSW.** Subchannel status word.

**SDLC.** Synchronous Data Link Control.

**security paper.** Specially formulated paper used for negotiable documents, such as checks, which improves the anti-fraud characteristics of the document.

**shift.** A scheduled work period. For example, a 24-hour day is often divided into three 8-hour shifts.

**simplex printing.** Pertaining to printing on only one side of a form. Contrast with *duplex printing*.

**single-byte character set (SBCS).** A character set in which each character is represented by a 1-byte code.

**sizing.** A process where paper is treated to give it resistance against penetration of liquids.

**SMM.** Select Medium Modification.

**SNA.** System Network Architecture.

**special-purpose materials.** Printable items other than blank forms; for example, adhesive labels and preprinted forms.

**stack lean.** A measurable slope from the vertical of a stack of forms. Excessive stack lean can cause failures when feeding and refolding forms.

**Synchronous Data Link Control (SDLC).** For managing synchronous, code-transparent, serial-by-bit, information transfer over a link connection.

**system reference code (SRC).** A code that contains information, such as a failing field-replaceable unit, for a customer engineer.

**system programmer.** A programmer who plans, generates, maintains, extends, and controls the use of an operating system, with the aim of improving overall productivity of an installation. Contrast with *application programmer*.

**System/370.** An upward-compatible extension of the IBM System/360. A large collection of computing system devices that can be combined to produce a wide range of computing systems that share many characteristics, including a common machine language.

## T

**task.** A basic unit of work to be accomplished by a device or an operator.

**TCP/IP.** Transmission Control Protocol/Internet Protocol. A set of communication protocols that support peer-to-peer connectivity functions for both local and wide area networks.

**TCS.** Two-channel switch.

**tensile strength.** A measure of the force that the paper forms can withstand without tearing.

**test mode.** The operational mode in which the printer can produce print samples, accept configuration changes, and control traces. When the InfoPrint 3000 are in test mode, they is not accepting information from the attached controlling computer system. Contrast with *print mode* and *diagnostic mode*.

**text orientation.** The position of text as a combination of print direction and baseline direction.

**tie.** The interval between cuts of a perforation.

**token.** In a local area network, a particular message or bit pattern passed successively from one attaching device to another to indicate which attachment has permission to transmit.

**token ring.** A network with a ring topology that passes tokens from one attaching device to another.

**toner.** The material that forms the image on the paper.

**trace.** (1) A record of the running of a computer program. It exhibits the sequences in which the instructions were executed. (2) To record a series of events as they occur. (3) In the InfoPrint 3000, a customer engineer and customer analysis procedure.

**tractor.** The mechanism that controls movement of continuous forms by way of holes.

**tractor holes.** The holes in the side margins on continuous forms. When placed on the tractor pins, the holes maintain printer alignment and registration, and control the movement of the paper.

**Two-channel switch (TCS).** A hardware facility that allows an input or output device to be attached to two channels. In a 3900 Advanced Function Printing System, this facility is automatically supplied when two System/370 Parallel channels are installed.

## U

**up fold.** Fanfold forms are alternately folded. When fanfold forms are unfolded and held horizontally, a fold is an up fold if it points up from the horizontal surface.

## V

**variable data.** The data that can vary; for example, the names and addresses in form letters.

**vector graphics.** Computer graphics in which display images are generated from display commands and coordinate data. Contrast with *raster pattern*.

**Virtual Storage Extended (VSE).** An operating system that is an extension of Disk Operating System/Virtual Storage (OS/VS).

**Virtual Storage Extended/Advanced Functions (VSE/AF).** The minimum operating system support for a VSE-controlled installation.

**VSE/SP.** Virtual Storage Extended/System Product.

**void.** (1) A missing part of the printed character. (2) A missing piece of a continuous form.

## X

**X-axis.** In printing, the axis perpendicular to the direction in which the paper moves through the printer.

## Y

**X-axis.** In printing, the axis parallel with the direction in which the paper moves through the printer.



---

# Index

## A

absorbent oil pad, checking 212  
adding  
  developer mix 191  
  forms definitions 247  
  fuser oil 179  
  pre/postprocessing device interfaces 241  
  supplies 119  
  toner 182  
adjusting  
  Display Touch Screen monitor 65  
  horizontal print 72  
  labels, print position 72, 73  
  new forms, print position 72, 73  
  print, preprinted forms 72, 73  
  print position 68  
  vertical print 73  
  volume, operator alert 74  
alarm does not sound 270  
analyze pull-down menu 49  
attachments  
  configuring 229  
  disabling 63  
  enabling 63  
authorization level, changing 79  
auto load jams 269

## B

belt, oiler 177  
  changing 204  
  cleaning 86, 204  
  gate 87, 206, 213  
  hot roll shield 87, 210, 215  
  location of 26  
  message 204  
  new belt 204  
  oil pan, absorbent pad 212  
  roll 208  
blank areas 267  
blank Display Touch Screen display 269  
bloom, print 268  
brush, corona 91  
brush, static discharge 93  
buffer/flipper unit, threading 167

## C

cable  
  locations 293  
call for service, procedure 13  
Cancel Job (Main Window pushbutton) 35  
canceling print jobs 78  
changing  
  absorbent pad in oil pan 212  
  attachments configuration 229  
  developer mix 191  
  Display Touch Screen language 218

changing (*continued*)  
  duplex to simplex mode 220  
  ESCON channels configuration 234  
  Ethernet attachments 237  
  FDDI attachments 239  
  fine filter 201  
  forms definitions 247  
  oiler belt 204  
  operator authorization level 79  
  parallel channels configuration 232  
  password 79  
  preprocessing/postprocessing device configuration 241  
  printer configuration 219  
  printer mode 172, 220  
  simplex to duplex mode 220  
  token ring attachments 235  
  toner collector 188  
channel  
  cable locations 293  
characteristics  
  printer 3  
  summary 3  
  system 1  
check collector, toner 186  
checking  
  fine filter 200  
  forms alignment 84  
  print samples 85  
cleaning  
  brush, corona 91  
  charge corona 90  
  developer area 90  
  forms input area 92  
  oiler belt 86, 88  
  preclean corona 90  
  printer 88  
  rear service area 99  
  sensors, EOF 92  
  stacker area. 95, 97  
  static discharge 93  
  tools required  
    paper towels 88  
    vacuum cleaner, toner-certified 88  
  transfer corona 95  
  transfer station area 93  
  vacuum cleaner 88  
clearances 293  
clearing forms jams  
  jams between postprocessing 126  
  prevention suggestions 144  
  procedures 126  
  procedures (duplex mode) 127, 134  
  procedures (simplex mode) 121, 126  
  transfer station area 136  
clearing the forms path  
  fuser and stacker areas 140  
  jams between postprocessing 126  
  stacker and pendulum area 143  
  transfer station area 136  
clock symbol 41

collector, toner 177  
concurrent procedures 39  
configuration worksheets  
  attachments 251, 258  
  forms 263  
  printer 251, 258  
  supplies 176  
configure pull-down menu 47  
configuring remote access 245  
configuring the system  
  attachments 229  
  Display Touch Screen language 218  
  ESCON channels 234  
  Ethernet attachments 237  
  FDDI attachments 239  
  forms definitions 247  
  parallel channels 232  
  preprocessing/postprocessing devices 241  
  printer 219  
  procedures 217, 265  
  token ring attachments 235  
  worksheets 251, 258  
connecting accessories, customer alert device 101  
control unit functional area 17  
controlling system power 56, 60  
corona  
  charge 90  
  cleaning brush 91  
  preclean 90  
  transfer 95  
cues, visual 41  
customer alert device, connecting 101  
customer engineer password protection 79

## D

dark  
  background 268  
  print 266  
  streaks 268  
defining forms 247  
deleting  
  forms definitions 247  
  pre/postprocessing device interface 241  
  print jobs 78  
developer  
  cleaning 88, 90  
  developer inlet 20  
  drain hose 194  
  drain lever 20, 21, 195  
  drain mix inlet icon 21  
  inlet cover 199  
  message 191  
  mix drain hose 22  
  mix inlet 20, 195  
  run 21, 23  
  run pushbutton 20, 195

- developer (*continued*)
  - warning message 197
- developer area
  - cleaning 90
  - developer inlet 20
  - drain 21
  - drain lever 20
  - inlet 20
  - mix drain hose 22
  - mix inlet 20
  - run 21, 23
  - run pushbutton 20
  - toner inlet 20
  - toner supply pushbutton 20
- developer mix 177
- developer mix, replacing 198
- dirty prints 268
- disabling a host attachment 63
- display touch screen
  - changing language 218
  - description 18
  - monitor, adjusting 65
  - symbols and visual cues 41
  - timeout, screen saver 40
  - using 33, 43
  - using in duplex modes 33
  - using in simplex modes 33
- Display Touch Screen windows 34
- double images 267
- down fold
  - indicator and key 24
  - printer control panel 24
- drain hose, developer 194
- dual simplex mode, changing to 172
- duplex mode, changing to 172, 220

## E

- ED2, Model 3
- eject to front-facing page 81
- ellipsis, on console items 41
- empty the stacker 169
- enabling a host attachment 63
- ES1, Model 3
- ESCON channel configuration 234
- Ethernet attachment configuration 237

## F

- false end of forms 270
- FDDI attachment configuration 239
- field, menu
  - non-selectable 41
  - scroll bar 41
  - scroll box 41
  - selectable 41
- filter, fine 177
- fine filter 177
  - checking 200
  - cover 32
  - replacing 201
- finger belts 27
- fingertip control 37
- forms
  - adding or changing 247
  - defining 247

- forms (*continued*)
  - definition 15
  - deleting 247
  - guide 26
  - identification worksheets 263
  - input functional area 22
  - jammed, torn, or separated 123
  - not jammed, torn, or separated 124
  - path 15
  - sticking together 151
  - unloading 169
- forms, loading
  - load 102
- forms alignment
  - checking 84
  - guide line 26
  - scale 81
- Forms Feed 29
- Forms Feed key 24
- FORMS LENGTH knob 30
- Forms Select key 29
- forms selection
  - A, setting 29
  - B, setting 29
  - C, setting 29
- Forms Set 84
- Forms Set indicators and key 24
- FORMS WIDTH lever 30
- Forward forms feed key 24
- frequent stops and starts 270
- front-facing page 81
- function keys not responding 269
- functional areas 15
  - control unit 17
  - developer 20
  - forms input 22
  - forms path 15
  - fuser entry 26
  - pre/post device switch 32
  - rear service 32
  - stacker 27
  - transfer station 22
- funnel, oil bottle 180
- fuser
  - entry area 26
  - fuser 124
  - gate 26
  - oil, adding 179
  - oil reservoir 32
- fuser oil 177

## G

- grayed out text 41

## H

- handling messages 271, 291
- hard program checks messages 273
- help
  - procedure windows 53
- help window 52
- hexpad
  - symbol 41
- hexpad window 35
- horizontal print position 72

- host controlled mode 58
- hot roll 15, 26
- hot roll shield 87

## I

- icons
  - developer mix inlet 21
- IMLing the printer 61
- inactive items 38
- indicators
  - left fold 24
  - right fold 24
- intervention required messages 277
- irregular speed, forms 270

## J

- jam prevention, suggestions 144
- jam recovery 119
  - fuser 129
  - fuser area 140
  - pendulum area 143
  - skew error 123, 124, 129, 130, 131, 132
  - stacker 125
  - suggestions 144
  - tractor jam 123
  - transfer station area 136
  - upper tractor 129, 130, 131, 132
  - within the printer engine 122
- jobs, canceling 78

## K

- key operator
  - password protection 79
- keyboard symbol 41
- keyboard window 35
- keypad
  - Forms Select 29
  - symbol 41
- keypad window 35
- keys
  - description of 37
  - developer run 20
  - Forward 24
  - left fold 24
  - Reverse 24
  - right fold 24
  - TABLE 29
  - toner supply 20
- knobs
  - FORMS LENGTH 30

## L

- labels
  - printing 72, 73
- labels, printing 72, 73
- language, changing for Display Touch Screen 218
- laser 15
- left fold indicator and key 24

- lever, operator control
  - developer drain 20
  - FORMS WIDTH 30
  - tractor control 25
  - transfer station control 25
- Lexmark International 177
- light areas 267
- light print 267
- load forms
  - load 102
- Local Control Unit Power switch 18, 56
- local controlled mode 59
- Local Printer Power switch 18, 56
- Local/Remote switch (power) 19

## M

- Main Window, Display Touch Screen 34
- menus
  - analyze 49
  - configure 47
  - Help 52
  - operate 45
  - options 50
- message displayed too long 269
- messages and codes
  - hard program checks 273
  - intervention required 277
  - out of supplies 276
  - printer error 274
  - program check 272
  - responding to 271, 280, 291
  - soft program check 272
  - status 278
- miscellaneous symptom table 269
- mix, developer 20, 177
- modem, remote access 245
- monthly usage, reporting 146
- multiple procedures 39

## N

- new forms, adjust print 72, 73
- non-process runout (NPRO) 46, 75
- non-selectable field 41
- not ready status 12
- NPRO
  - Main Window pushbutton 35
  - NPRO Page 76
  - Operate procedure 46, 75
  - procedure 75
  - single sheet advance 76
- NPRO Page 46, 76

## O

- oil, adding fuser 179
- oil, fuser 177
- oil pan, checking absorbent pad 212
- oil reservoir 180, 181
- oiler belt 177
- oiler belt cleaning 86
- operate pull-down menu 45
- operator alert assembly 74
- operator authorization level, change 79

- operator instructions, pre and postprocessing 118
- operator intervention light 17
- operator panel 17
- operator responsibilities
  - password protection 79
  - summary of 9
  - task summary 43, 53
- options pull-down menu 50
- ordering IBM supplies
  - customer-replaceable items 177
  - developer mix 177
  - fine filter 177
  - fuser oil 177
  - maintenance items 177
  - oiler belt 177
  - ordering 177
  - storing 178
  - suggested quantities 176
  - toner 177
  - toner collector 177
  - warranty returns 178
  - worksheet 176
- ordering supplies 177
- out of supplies messages 276

## P

- page counter meter 146
- paper 15
- parallel channel configuration 232
- password
  - protection 79
- password, changing 79
- path, forms
  - definition 15
- pendulum 15, 27
- pointer 41
- poor fusing 151
- poor registration 267
- power, controlling 56, 60
- Power Off if in Local - Control Unit
  - Power switch 18, 56
- Power Off if in Local - Printer Power switch 18, 56
- Power Off If In Local switch 19
- Power On - Control Unit Power switch 18, 56
- Power On - Printer Power switch 18, 56
- power on/off 18, 56
- Power On/Reset switch 19
- power supply 15
- power switches 18, 56
- powering on and off
  - sequence 118
- pre/post device switch 32
- preheat control knob 151
- preprinted forms 72, 73
- preprocessing instructions 118
- preprocessing/postprocessing devices
  - adding supplies 119
  - clearing jams 126
  - configuring 241
  - enabling/disabling Pre/Post interfaces 118
  - error and jam recovery 119
  - nonprocess runout (NPRO) 75

- preprocessing/postprocessing devices
  - (continued)
  - nonprocess runout (NPRO) on pre/postprocessor 120
  - nonprocess runout (NPRO) page 75
  - powering on and off 118
  - single sheet advance 76
  - using the printer stacker 119
- prevention, jam suggestions 144
- print
  - adjustment 68
  - bloom 268
  - quality
    - checking 85
    - checking print samples 85
    - problems 85
    - quality symptom table 266
    - rubs off 267
- print position settings
  - horizontal 72
  - vertical 73
- print resolution, switching 174
- Print Samples (Analyze procedure) 49
- printer
  - characteristics 3
  - cleaning 88
  - display windows 33
  - error messages 274
  - jobs, canceling 78
  - reporting usage 146
- printer display touch screen
  - description 23
  - Forms Feed key 24
  - Forms Select key 29
  - Forms Set indicators and key 24
- printer icons
  - developer mix inlet 21
- printer modes, switching from dual simplex or duplex 172
- printing
  - labels 72, 73
  - position 72, 73
- problems, print-quality 85
- procedure window helps 53
- program check messages 272
- pull-down menus
  - analyze 49
  - configure 47
  - Help 52
  - operate 45
  - options 50
- puller 15
- puller lever 26
- pushbuttons
  - description of 37
  - developer run 20
  - Forward 24
  - left fold 24
  - Reverse 24
  - right fold 24
  - TABLE 29
  - toner supply 20

## R

- radio buttons 38
- Ready (Main Window pushbutton) 34

- Ready (Operate procedure) 45
- ready status 11
- rear service area 32
- recovering from forms jams (duplex operations)
  - forms are not jammed, torn or separated 130
  - jam between printer 1 and printer 2 134
  - jams between the printer and a postprocessing device 134
  - jams within printer 1 129
  - jams within printer 2 131
  - procedures (duplex mode) 127, 134
- recovering from forms jams (simplex operations)
  - forms are jammed, torn, or separated 123
  - forms are not jammed, torn, or separated 124
  - jams between postprocessing 126
  - prevention suggestions 144
  - procedures 126
  - procedures (simplex mode) 121, 126
  - transfer station area 136
  - within the printer engine 122
- recovery, jam 119
- reduced print quality 266
- reducing print quality 29
- registration 68
- remote access, configuring 245
- Remote Channel Enable/Disable feature 63
- Remote Control Unit Power switch 18, 56
- Remote Management Interface (RMI) 245
- Remote Printer Power switch 18, 56
- repeating messages 269
- repeating spot patterns 266
- replacing
  - absorbent pad in oil pan 212
  - developer mix 191
  - fine filter 201
  - oiler belt 204
  - toner collector 188
- report printer use 146
- reservoir, oil 180, 181
- responding to messages 271, 291
- restarting the system 61
- Reverse forms feed key 24
- right fold, printer control panel 24
- RMI (Remote Management Interface) 245
- RPQs 51
- run traces 148

## S

- screen saver timeout 40
- scroll bar 38, 41
- scroll box 41
- Select Medium Modification (SMM) 255, 256, 257, 260, 261, 262
- selectable field 41
- selectable fields 37
- Service Actions (Analyze procedure) 49

- service call procedure 13
- service clearances 293
- service representative password protection 79
- setting print positions
  - horizontal 72
  - vertical 73
- shutting down the system 61
- Simple Network Management Protocol (SNMP) 245
- simplex mode, changing to 220
- SMM (Select Medium Modification) 255, 256, 257, 260, 261, 262
- SNMP (Simple Network Management Protocol) 245
- soft program check messages 272
- Special features 51
- spout, oil 180
- stacker
  - area 27, 140, 143
  - cleaning 88
  - control panel 27
  - control panel, Forms Feed 29
  - control panel, FORMS WIDTH lever 30
  - control panel, TABLE switch 29
  - FORMS LENGTH knob 30
  - gate 27, 170
  - message 169
  - panel 27
  - table 27, 171
  - table switches 169
  - unloading 169
- static brush 25
- static discharge brush, cleaning 93
- status
  - not ready 12
  - ready 11
- status messages 278
- Stop (Main Window pushbutton) 34
- Stop (Operate procedure) 45
- storing
  - supplies 178
- streaks, white 267
- supplies
  - adding 119
  - customer-replaceable items 177
  - developer mix 177
  - fine filter 177
  - fuser oil 177
  - maintenance items 177
  - oiler belt 177
  - ordering 177
  - replacing 175
  - storing 178
  - suggested quantities 176
  - toner 177
  - toner collector 177
  - warranty return 178
  - worksheet 176
- switches, power 18, 56
- switching print resolution 174
- switching printer modes (dual simplex/duplex) 172
- symbol, system menu 39
- symbols, console 41
- symptom table, print quality 266

- symptoms
  - alarm does not sound 270
  - any other problem 268
  - auto load jams 269
  - blank areas 267
  - blank Display Touch Screen display 269
  - dark background 268
  - dark print 266
  - dark streaks 268
  - dirty prints 268
  - double images 267
  - false end of forms 270
  - forms moving at irregular speed 270
  - frequent stops and starts 270
  - function keys not responding 269
  - light
    - areas 267
    - print 267
  - light areas 267
  - light print 267
  - message displayed too long 269
  - poor registration 267
  - print bloom 268
  - print rubs off 267
  - printer does not respond to controlling computer system 270
  - repeating message 269
  - repeating spot patterns 266
  - voids 267
  - white streaks 267
  - wide characters 266
- system characteristics 1
- system configurations and usage
  - dual simplex 8
  - duplex printing applications 4
  - inline 6
  - left angle 7, 8
  - simplex printing 5
  - system components 3
  - ED1, Model 3
- system menu symbol 39
- system-menu symbol 41
- system power, controlling 56, 60

## T

- TABLE switch 29
- thread/align forms 152
  - forms broken between printers 162
  - forms loaded through both printers 154
  - forms not loaded in printer 2 158
  - print while threading 156, 160, 165
  - threading without printing 155, 158
- threading buffer/flipper unit 167
- timeout, screen saver 40
- token ring attachment configuration 235
- toner 177
  - adding 182
  - cartridge 21
  - changing collector 188
  - check collector 186
  - collector
    - changing 188
    - location of 32
  - install one toner cartridge 182

- toner (*continued*)
  - supply pushbutton 20
  - toner inlet 20
  - toner supply low 182
- toner collector 177
- traces 148
- traces, running 148
- tractor control lever 25
- transfer station
  - area 22
  - cleaning 88
  - control lever 22, 25
  - tractor control lever 25
- triangle symbol 41

## U

- Unit Emergency switch 18, 56
- unload the stacker 169
- usage card 146

## V

- vacuum cleaner 176
- vacuum cleaner, toner-certified 88
- vertical print position 73
- vertical scroll bar 38
- visual cues 41
- voids, print 267

## W

- warning symbol, console 41
- watch symbol 41
- white streaks 267
- wide characters 266
- window
  - keyboard/keypad window symbol 41
  - more windows symbol 41
  - symbols and visual cues 41
- worksheet
  - supplies 176



---

## Readers' Comments — We'd Like to Hear from You

InfoPrint 3000  
Operator's Guide

Publication No. S544-5564-01

Overall, how satisfied are you with the information in this book?

	Very Satisfied	Satisfied	Neutral	Dissatisfied	Very Dissatisfied
Overall satisfaction	<input type="checkbox"/>	<input type="checkbox"/>	<input type="checkbox"/>	<input type="checkbox"/>	<input type="checkbox"/>

How satisfied are you that the information in this book is:

	Very Satisfied	Satisfied	Neutral	Dissatisfied	Very Dissatisfied
Accurate	<input type="checkbox"/>	<input type="checkbox"/>	<input type="checkbox"/>	<input type="checkbox"/>	<input type="checkbox"/>
Complete	<input type="checkbox"/>	<input type="checkbox"/>	<input type="checkbox"/>	<input type="checkbox"/>	<input type="checkbox"/>
Easy to find	<input type="checkbox"/>	<input type="checkbox"/>	<input type="checkbox"/>	<input type="checkbox"/>	<input type="checkbox"/>
Easy to understand	<input type="checkbox"/>	<input type="checkbox"/>	<input type="checkbox"/>	<input type="checkbox"/>	<input type="checkbox"/>
Well organized	<input type="checkbox"/>	<input type="checkbox"/>	<input type="checkbox"/>	<input type="checkbox"/>	<input type="checkbox"/>
Applicable to your tasks	<input type="checkbox"/>	<input type="checkbox"/>	<input type="checkbox"/>	<input type="checkbox"/>	<input type="checkbox"/>

Please tell us how we can improve this book:

Thank you for your responses. May we contact you?  Yes  No

When you send comments to IBM, you grant IBM a nonexclusive right to use or distribute your comments in any way it believes appropriate without incurring any obligation to you.

---

Name

---

Address

---

Company or Organization

---

Phone No.

**Readers' Comments — We'd Like to Hear from You**  
S544-5564-01



Cut or Fold  
Along Line

Fold and Tape

**Please do not staple**

Fold and Tape

PLACE  
POSTAGE  
STAMP  
HERE

IBM Corporation  
IBM Printing Systems Company  
Department H7FE, Building 003G  
Information Development  
P.O. Box 1900  
Boulder, CO USA 80301-9817

Fold and Tape

**Please do not staple**

Fold and Tape

S544-5564-01

Cut or Fold  
Along Line







Part Number: 63H6618  
File Number: S370/4300/9370-16\_\_

Printed in U.S.A.

S544-5564-01



63H6618

