

Robert G. Young, VITA Volunteer, New Holland, Pennsylvania

Molenaar, Aldert. Water Lifting Devices for Irrigation. Rome: Food and Agriculture Organization, 1956.

Inertia Hand Pump

The inertia hand pump described here (Figure 1) is a

fig1x101.gif (600x600)

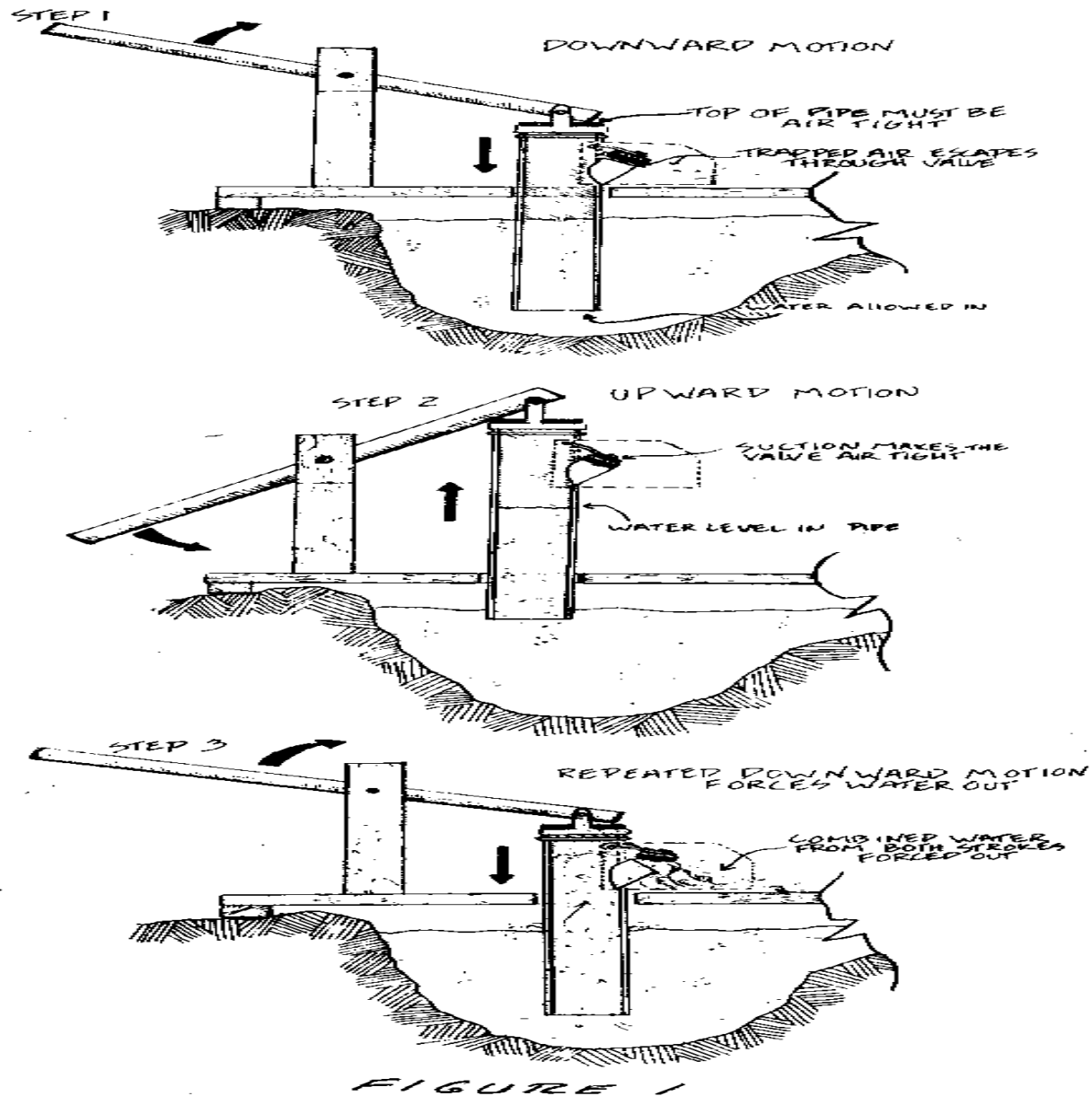

very efficient pump for lifting water short distances. It lifts water 4 meters (13') at the

rate of 75 to 114 liters (20 to 30 U.S. gallons) per minute. It lifts water 1 meter (3.3') at the rate of 227 to 284 liters (60 to 75 gallons) per minute. Delivery depends on the number of persons pumping and their strength.

The pump is easily built by a tinsmith. Its three moving parts require almost no maintenance. The pump has been built in three different sizes for different water levels.

The pump is made from galvanized sheet metal of the heaviest weight obtainable that can be easily worked by a tinsmith (24- to 28-gauge sheets have been used successfully). The pipe is formed and made air tight by soldering all joints and seams. The valve is made from the metal of discarded barrels and a piece of truck inner tube rubber. The bracket for

attaching the handle is also  
made from barrel metal.

Figure 1 shows the pump in  
operation. Figure 2 gives the

fig2x103.gif (600x600)

FIGURE 2

PART	MATERIAL	8CM PIPE	10 CM PIPE	15 CM PIPE
<b>HANDLE BRACKET</b>	<b>BARREL METAL</b>			
A		34 CM	40 CM	54 CM
B		24	30	44
C		8½	5	8½
D		7	10	17
<b>SHIELD</b>	<b>GALVANIZED TIN</b>			
E		43	49	61
F		14	16	20
G		14	16	20
H		3	3	2½
I		8	10	15
J		4	4	4
K		30	30	32
<b>SHIELD COVER</b>	<b>GALVANIZED TIN</b>			
L		15	17	21
M		20	20	22
N	<b>BARREL METAL</b>	6	8	12
O	<b>INNER TUBE RUBBER</b>	11	13	18
P	<b>BARREL METAL</b>	11	13	18
Q	<b>WIRE (4MM)</b>	16	18	22
<b>HANDLE</b>	<b>WOOD POLE</b>			
<b>POST</b>	<b>WOOD POST</b>			

dimensions of parts for pumps  
in three sizes and Figure 3

fig3x103.gif (393x393)

FIGURE 3

DIAMETER OF PIPE	LENGTH OF PIPE	HEIGHT OF LIFT	LITERS PER MINUTE AT 1830 METERS ELEVATION
8 CM	450 CM	2 TO 4 METERS	75 TO 114
10 CM	270 CM	1 TO 2 METERS	114 TO 152
15 CM	140 CM	1 METER	227 TO 284

shows the capacity of each size. Figures 4, 5, and 6 are

fig41030.gif (600x600)

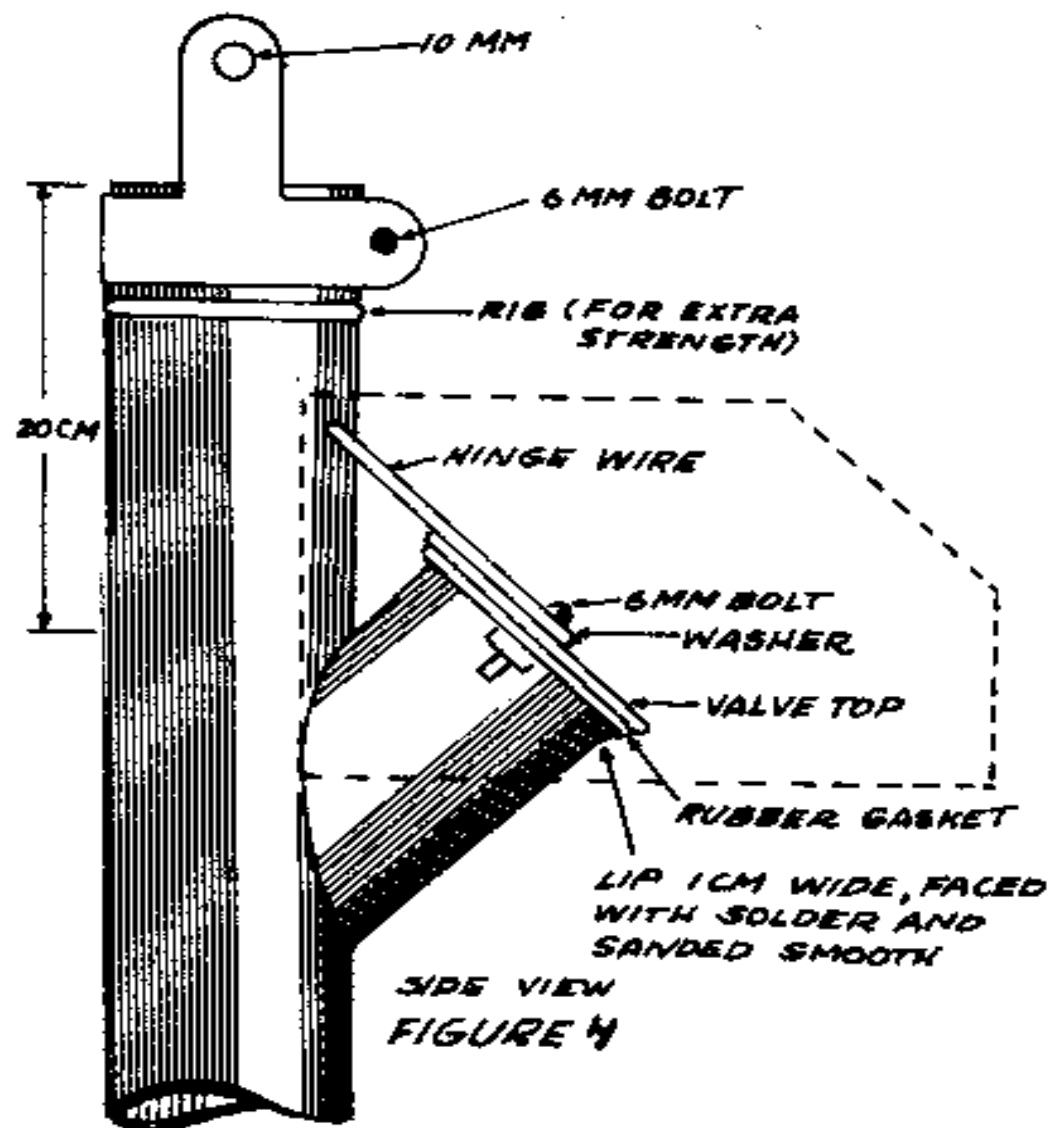

Tools and Materials  
(for 1-meter (3.3') pump)

**Soldering equipment****Drill and bits or punch****Hammer, saws, tinsnips****Anvil (railroad rail or iron pipe)****Galvanized iron (24 to 28 gauge):****Shield: 61cm x 32cm, 1 piece (24" x 12 5/8")****Shield cover: 21cm x 22cm, 1 piece (8 1/4" x 8 5/8")****Pipe: 140cm x 49cm, 1 piece (55 1/8" x 19 1/4")****Top of pipe: 15cm x 15cm, 1 piece (6" x 6")****"Y" pipe: 49cm x 30cm, 1 piece (19 1/4" x 12")****Barrel metal:****Bracket: 15cm x 45cm, 1 piece (6" x 21 1/4")****Valve-bottom: 12cm (4 3/4") in diameter, 1 piece****Valve-top: 18cm (7 1/8") in diameter, 1 piece****Wire:****Hinge: 4mm (5/32") in diameter, 32cm (12 5/8") long**

This pump can also be made from plastic pipe or bamboo.

There are two points to be remembered concerning this pump. One is that the distance from the top of the pipe to the top of the hole where the short section of pipe is connected must be 20cm (8"). See Figure 4. The air that stays in the

fig4x103.gif (600x600)



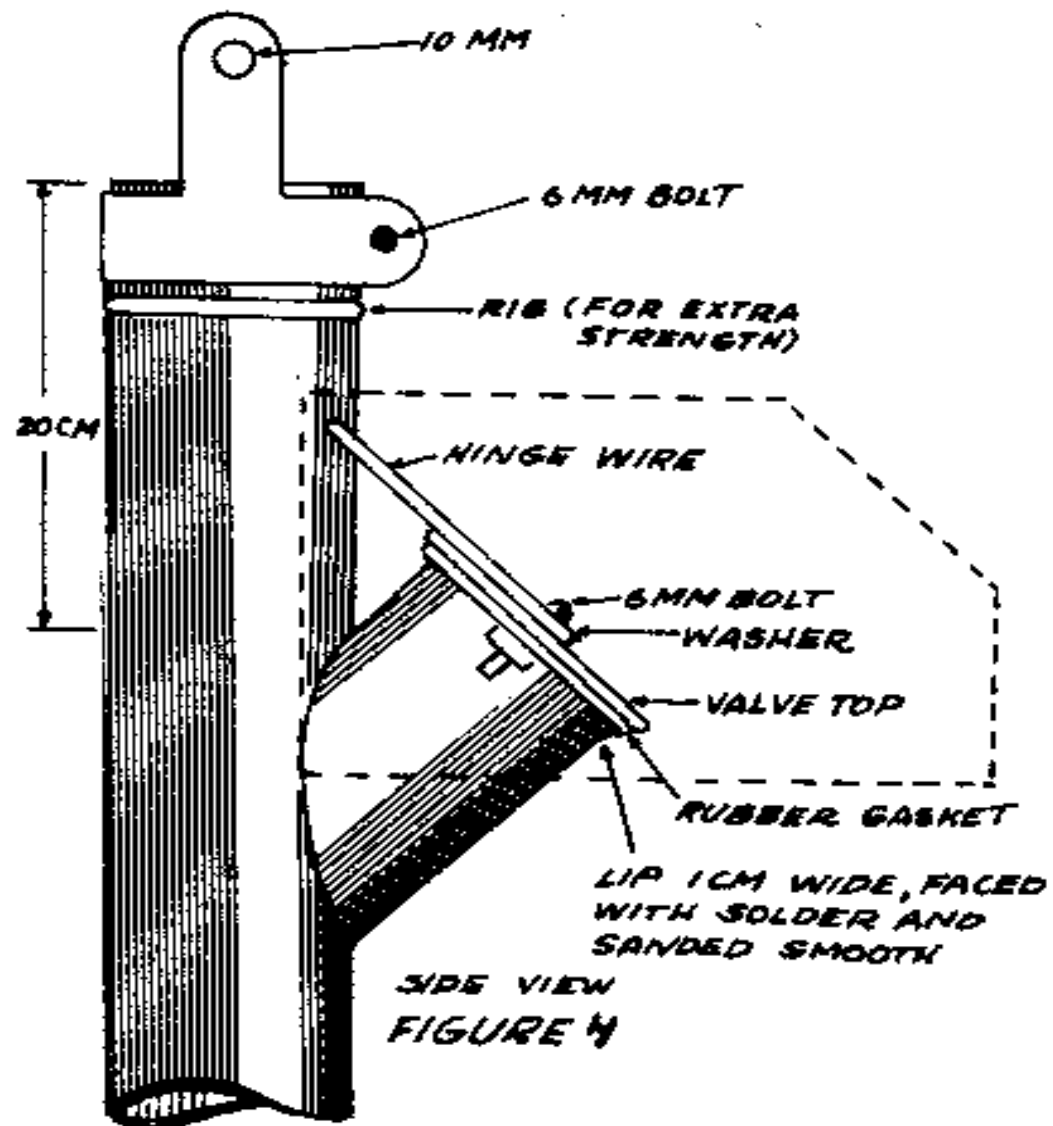

pipe above this junction serves as a cushion (to prevent "hammering") and regulates the number of strokes pumped per minute. The second point is to remember to operate the pump with short strokes, 15 to 20cm (6" to 8"), and at a

rate of about 80 strokes per minute. There is a definite speed at which the pump works best and the operators will soon get the "feel" of their own pumps.

In building the two larger size pumps it is sometimes necessary to strengthen the

pipe to keep it from collapsing if it hits the side of the well. It can be strengthened

by forming "ribs" about every 30cm (12") below the valve or banding with bands made from barrel metal and attached with 6mm (1/4") bolts.

The handle is attached to the pump and post with a bolt 10mm (3/8") in diameter, or a large nail or rod of similar size.

Source:

Dale Fritz, VITA Volunteer, Schenectady, New York.

### Handle Mechanism for Hand Pumps

The wearing parts of this durable handpump handle mechanism are wooden (see Figure 1).

fig1x105.gif (600x600)